

240 min

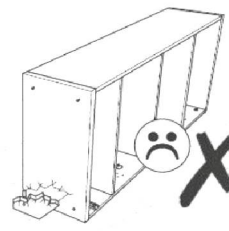

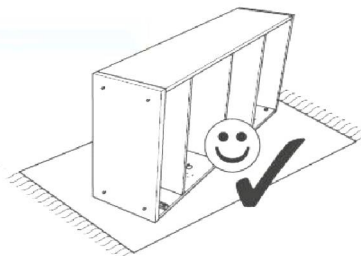

1/5	2, 3, 7, 11, 12, 13, 14, assembly instructions
2/5	1, 4, 5, 6, 8, 9
3/5	16, 17, 18, 19
4/5	Steel frame, mechanism, fittings
5/5	Handle, LED lights

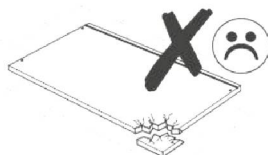
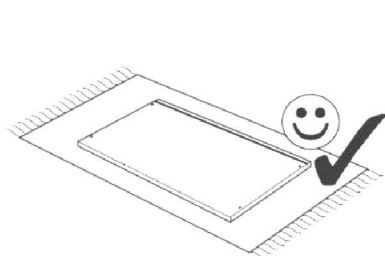
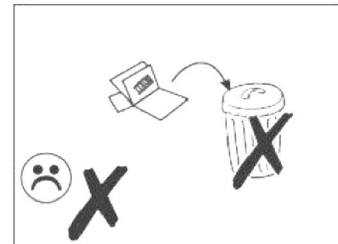
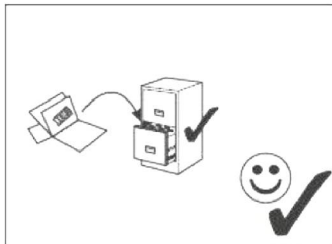
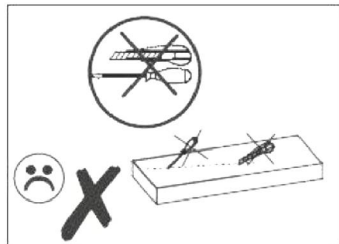
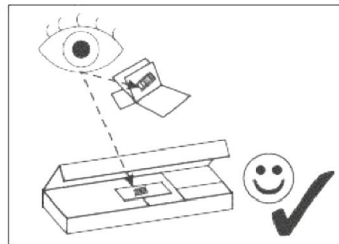
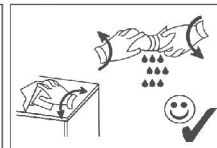
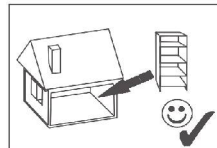
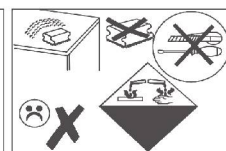
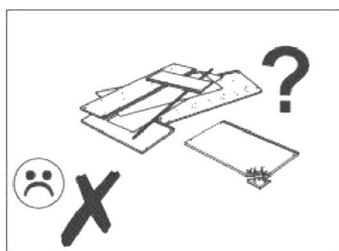
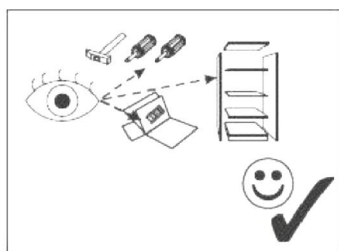
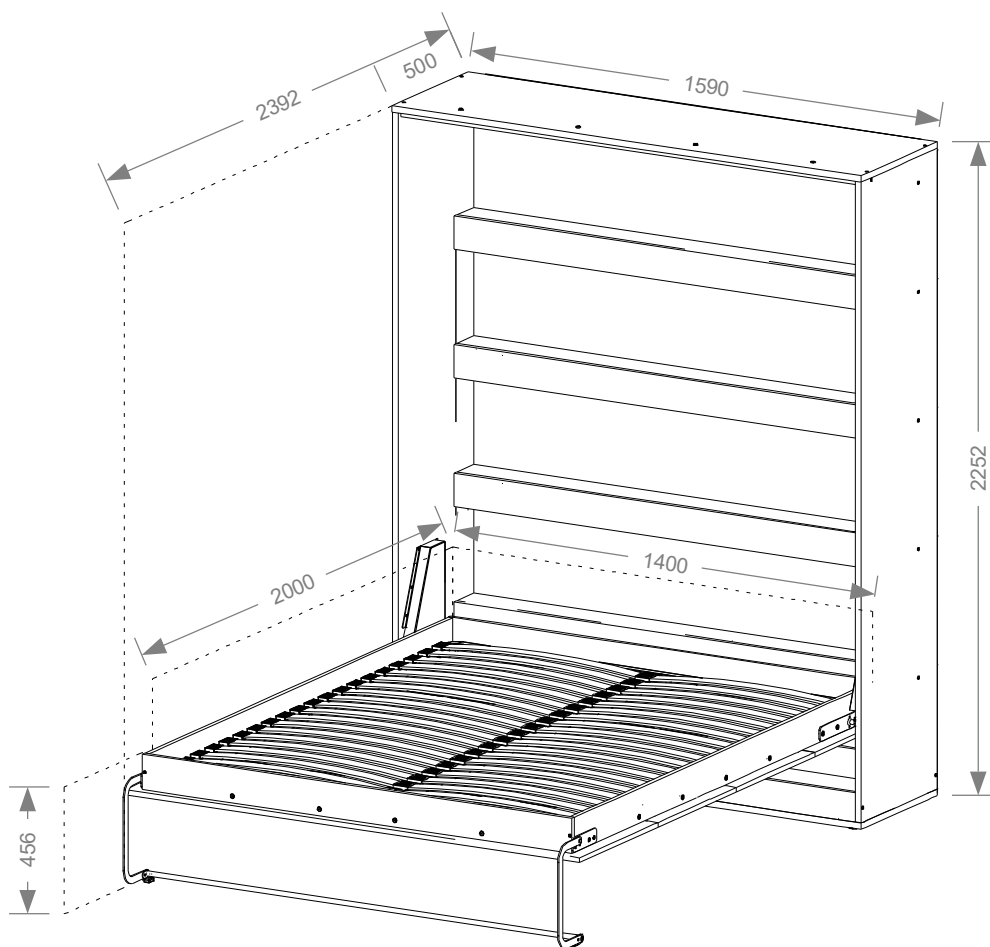
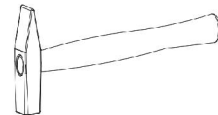
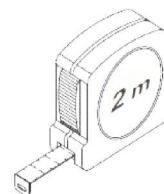
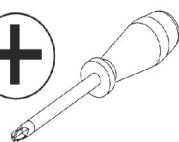
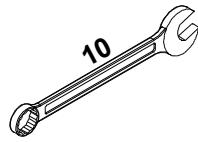
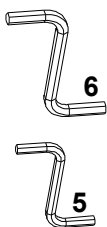
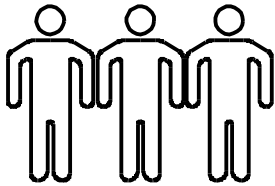
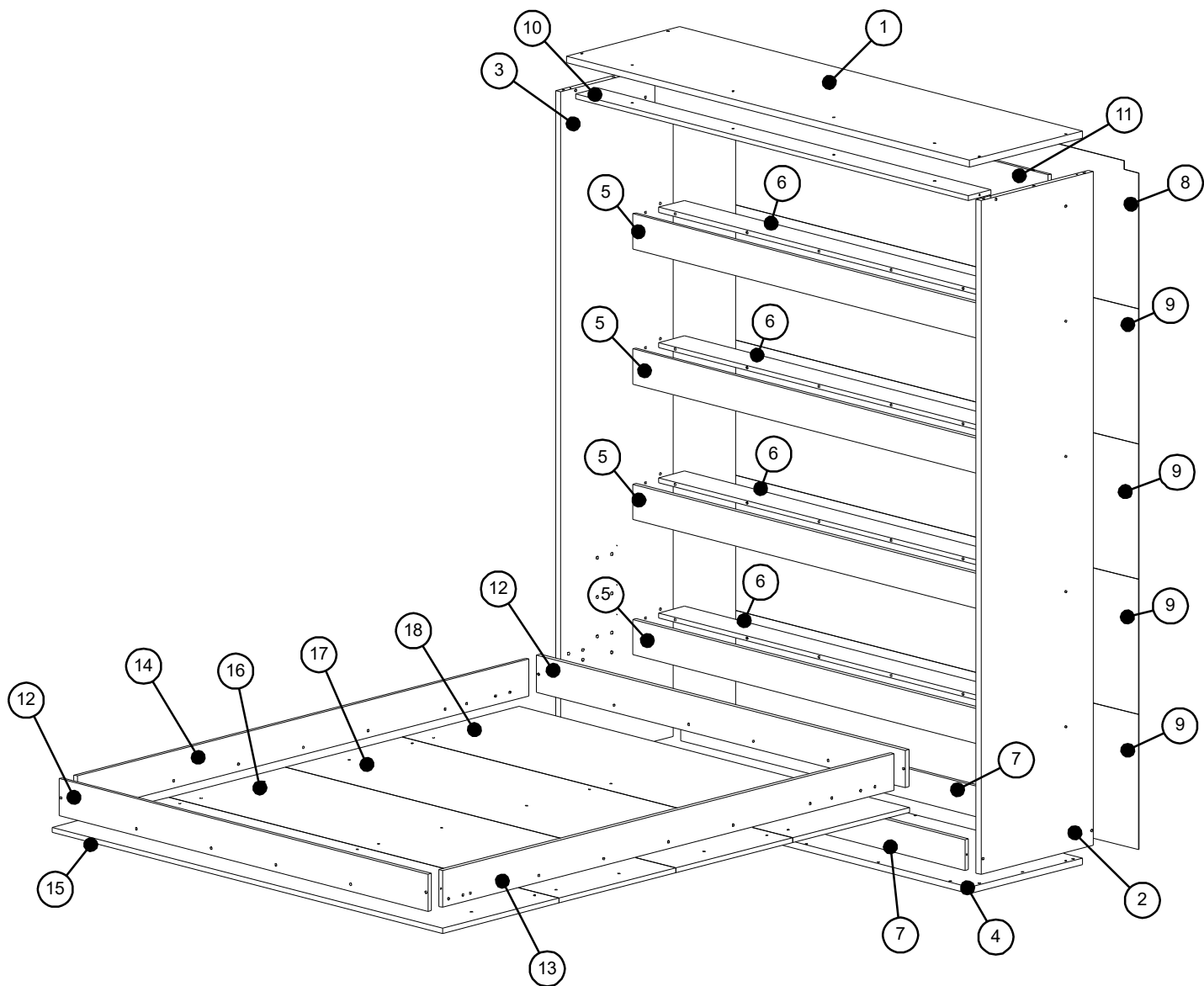
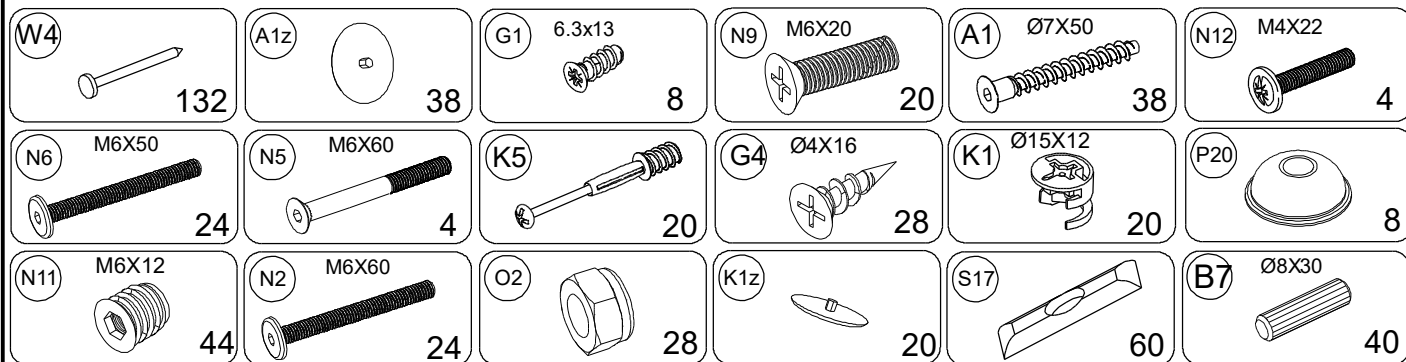

0 1 2 3 4 5 6 7 8 9 10 11 12 13 14 15 16 17 18

1

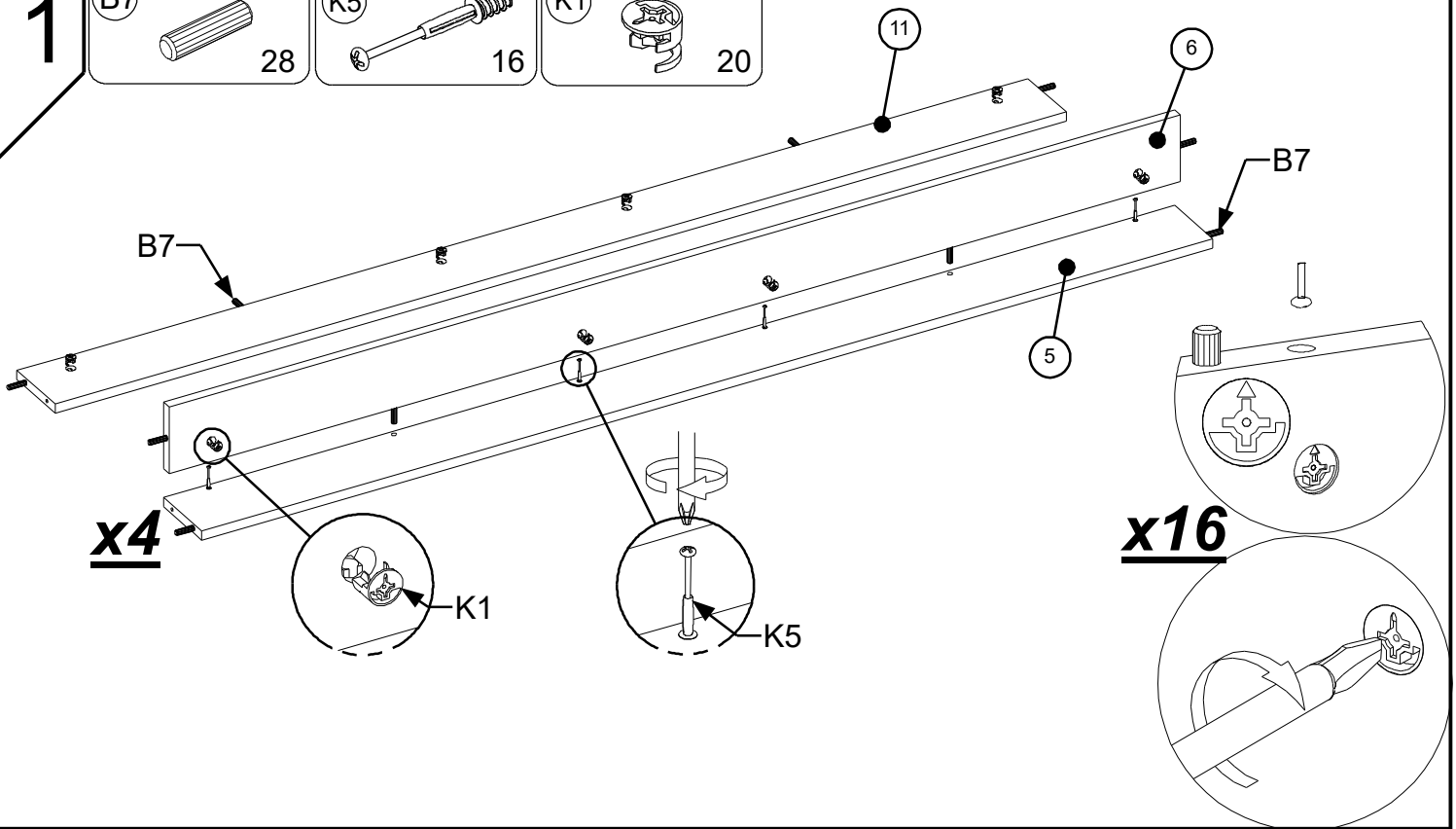
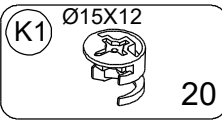
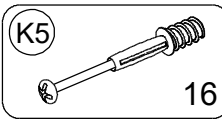
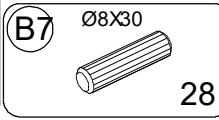

2

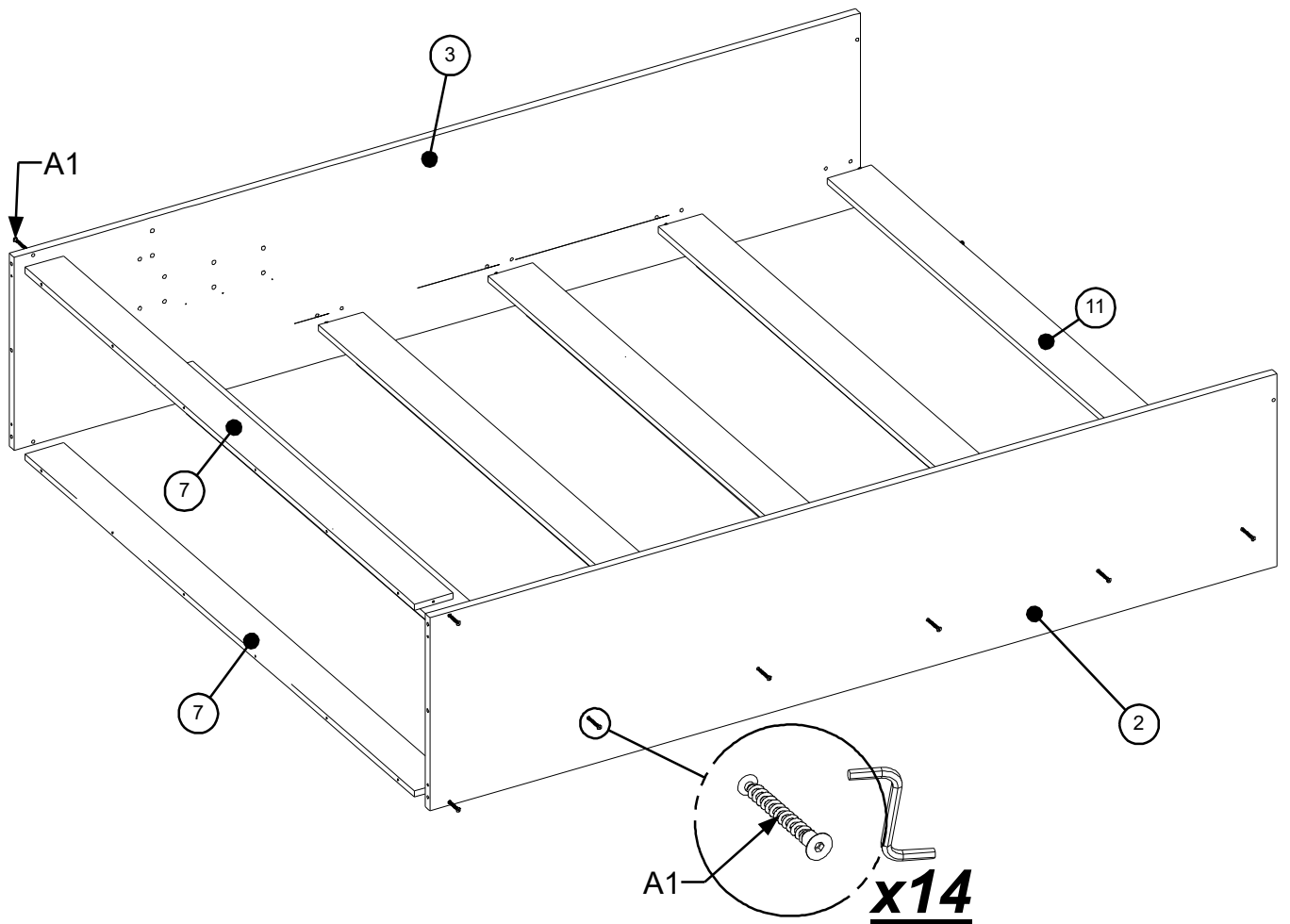
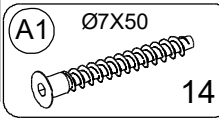

3

3

- (B7) Ø8X30 12
- (P20) 8
- (G4) Ø4X16 8
- (K5) 4
- (A1) Ø7X50 20

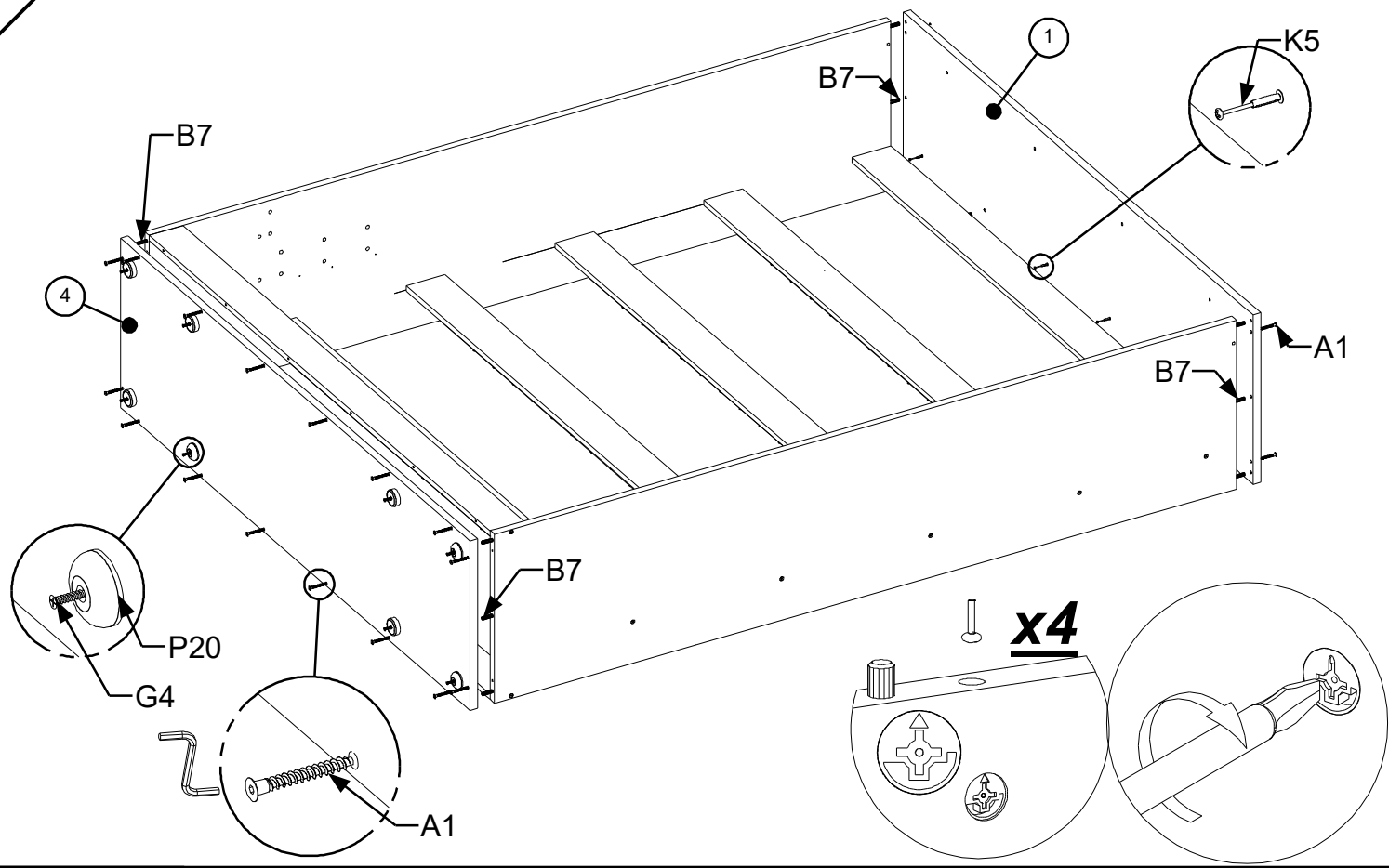

4

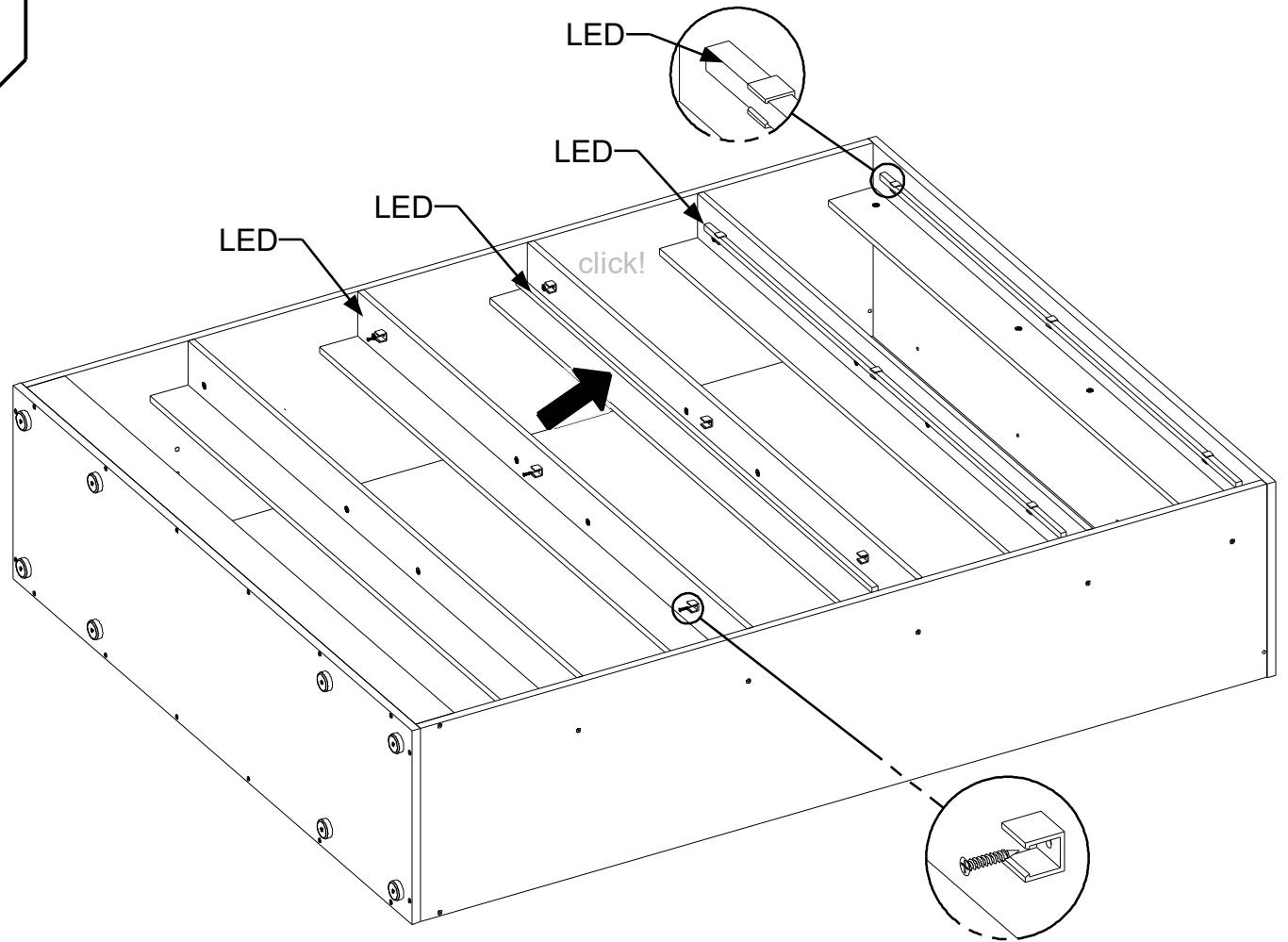

4

5

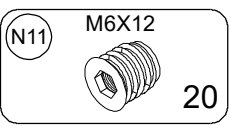
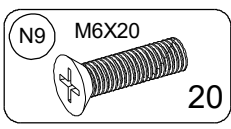
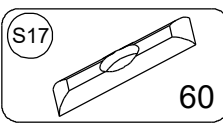
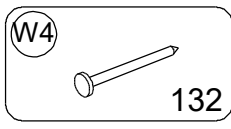

A = B

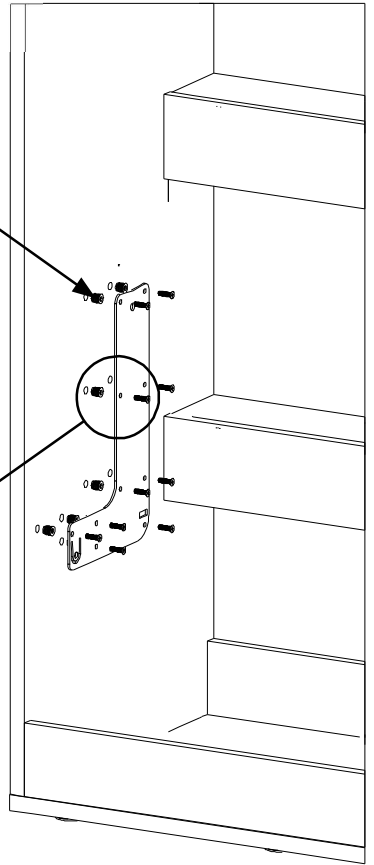
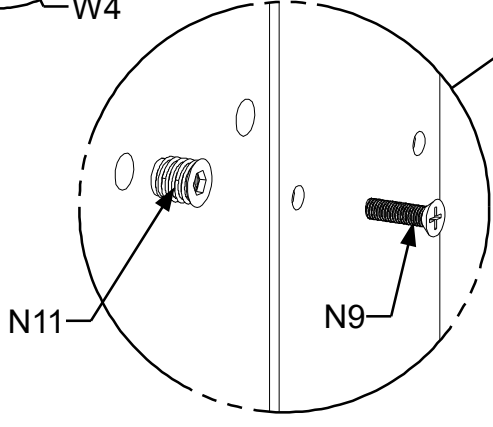
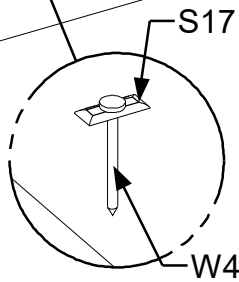
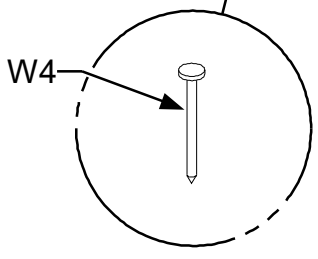
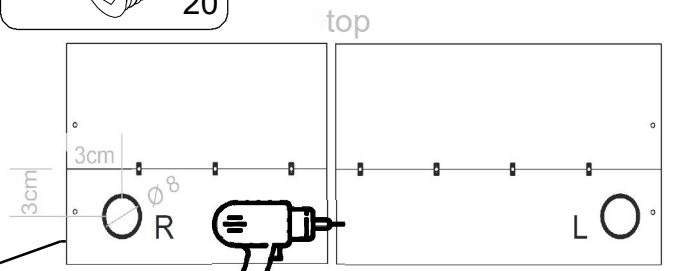
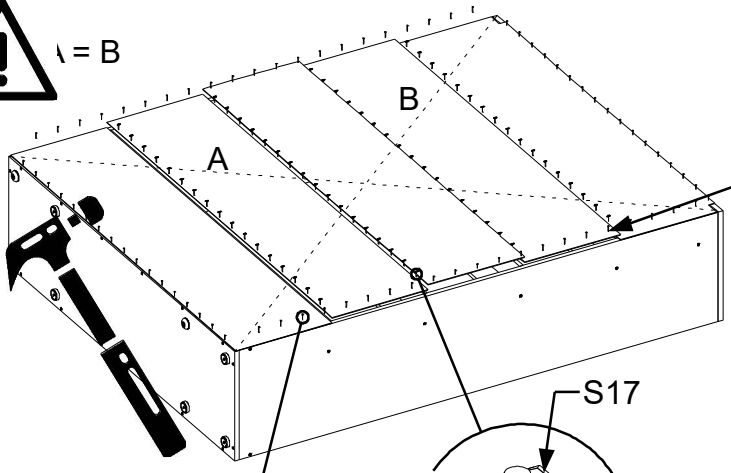

6

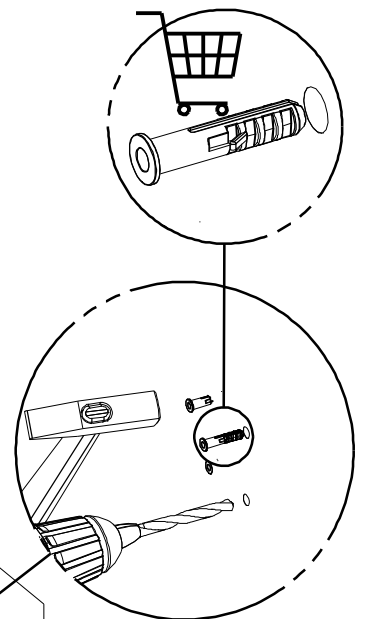
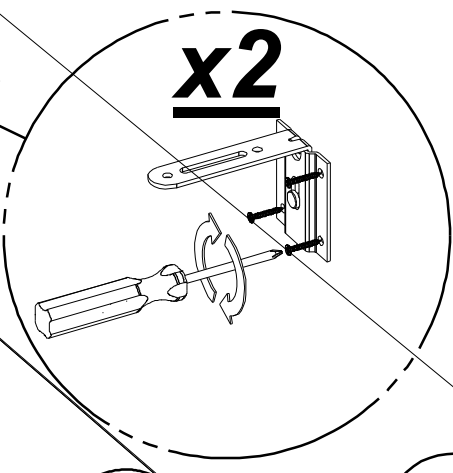
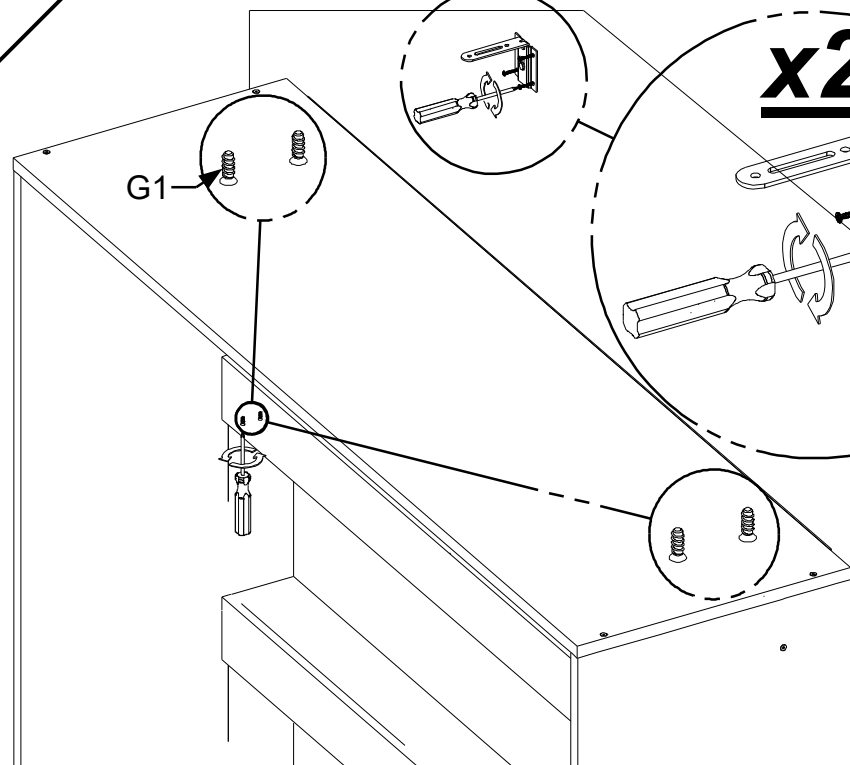
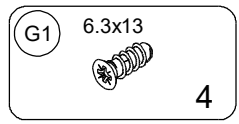

5

7

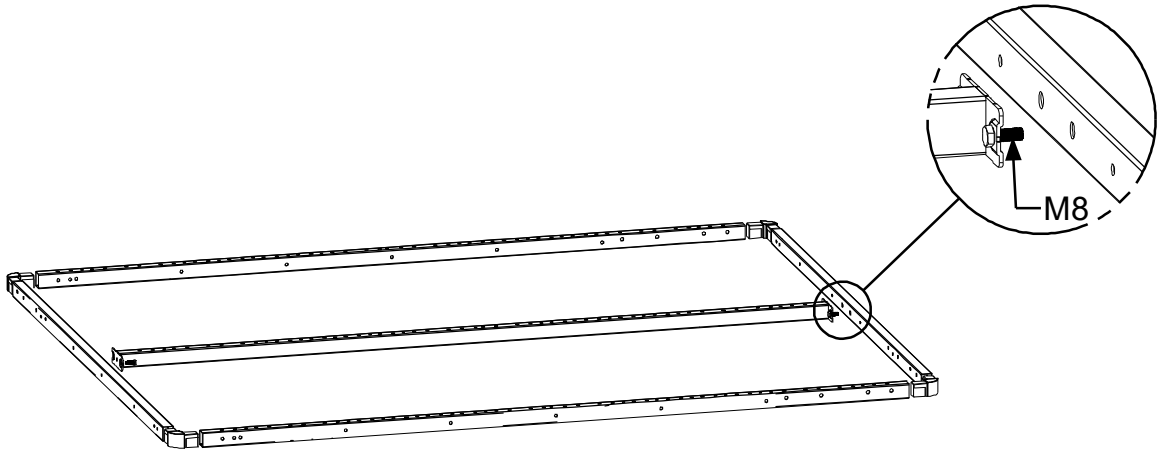

8

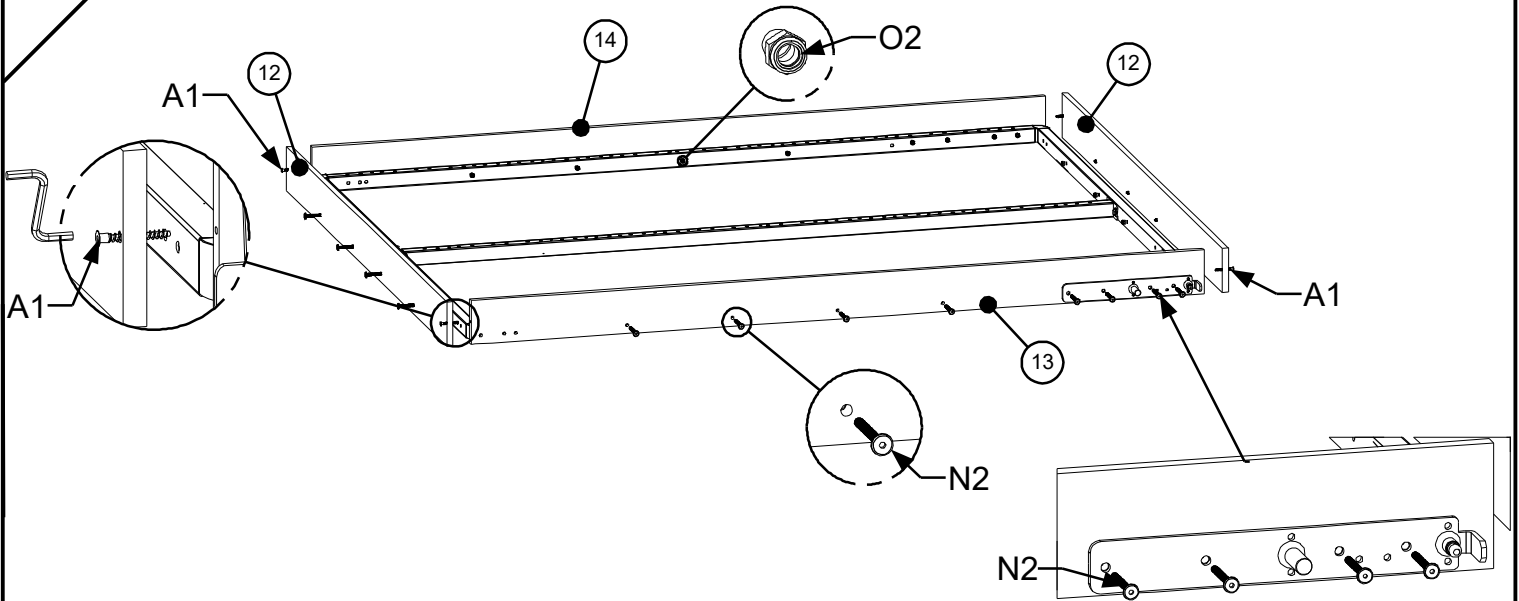
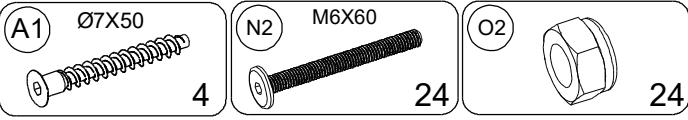

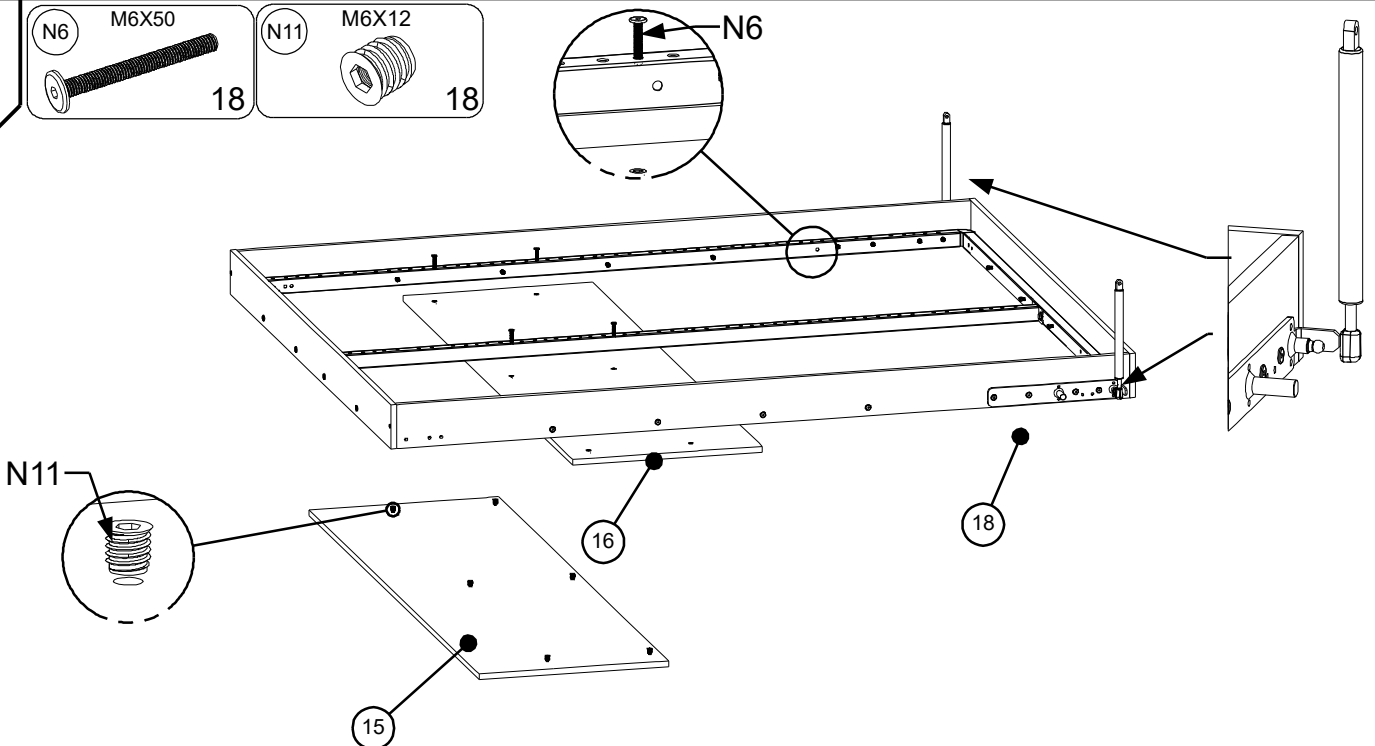
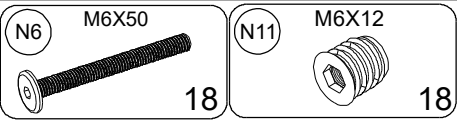

9



6

10

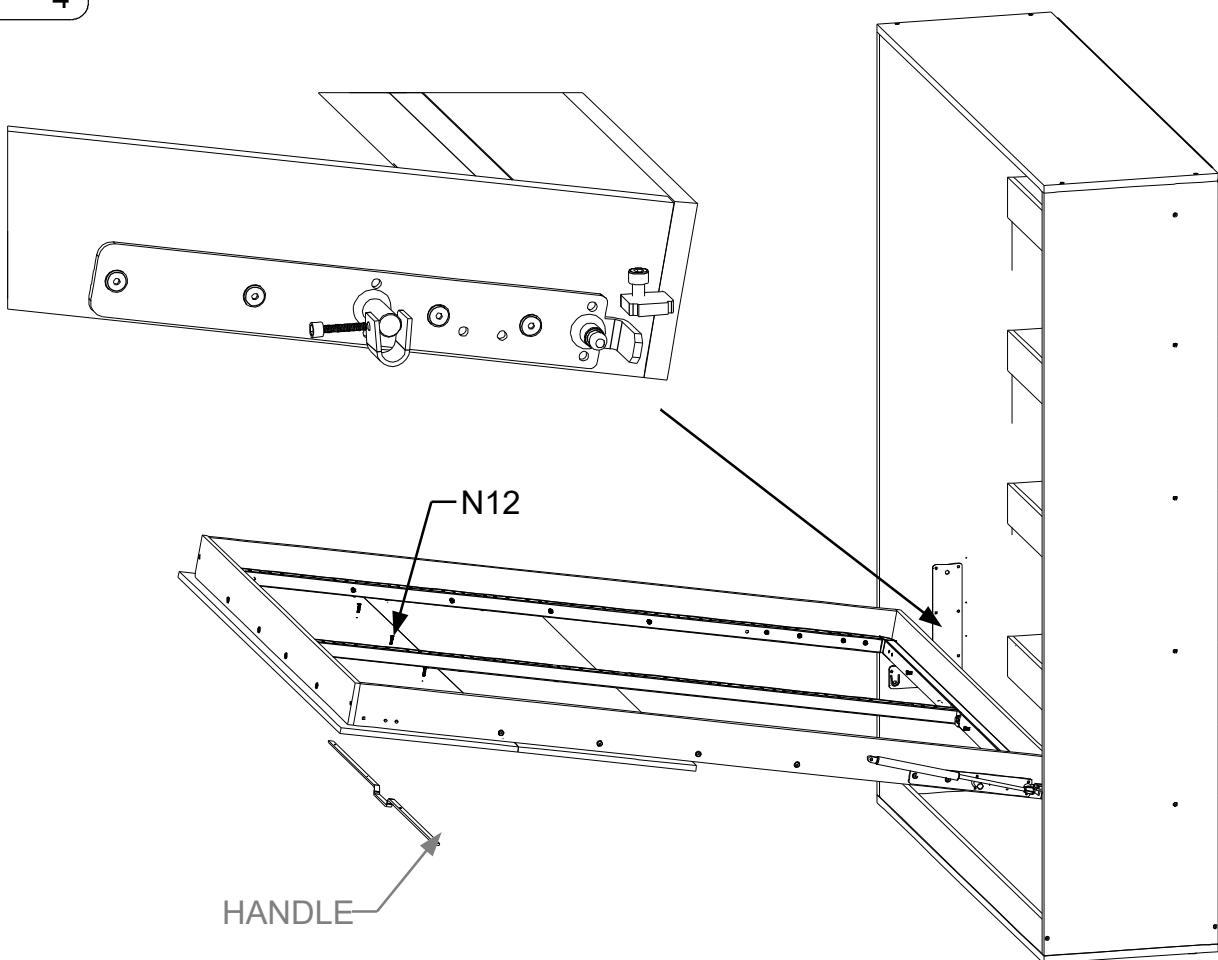
N12 M4X22 4



11

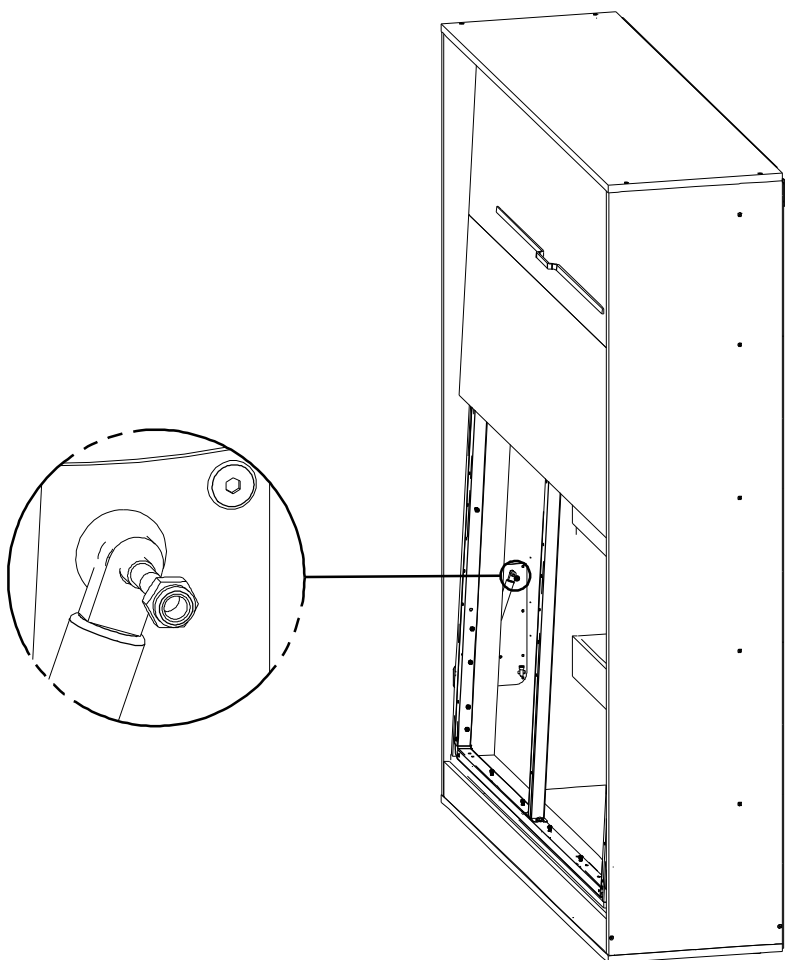

12

- G4 Ø4X16 14
- N6 M6X50 6
- G1 6.3x13 4
- N11 M6X12 6
- N5 M6X60 4
- O2 4

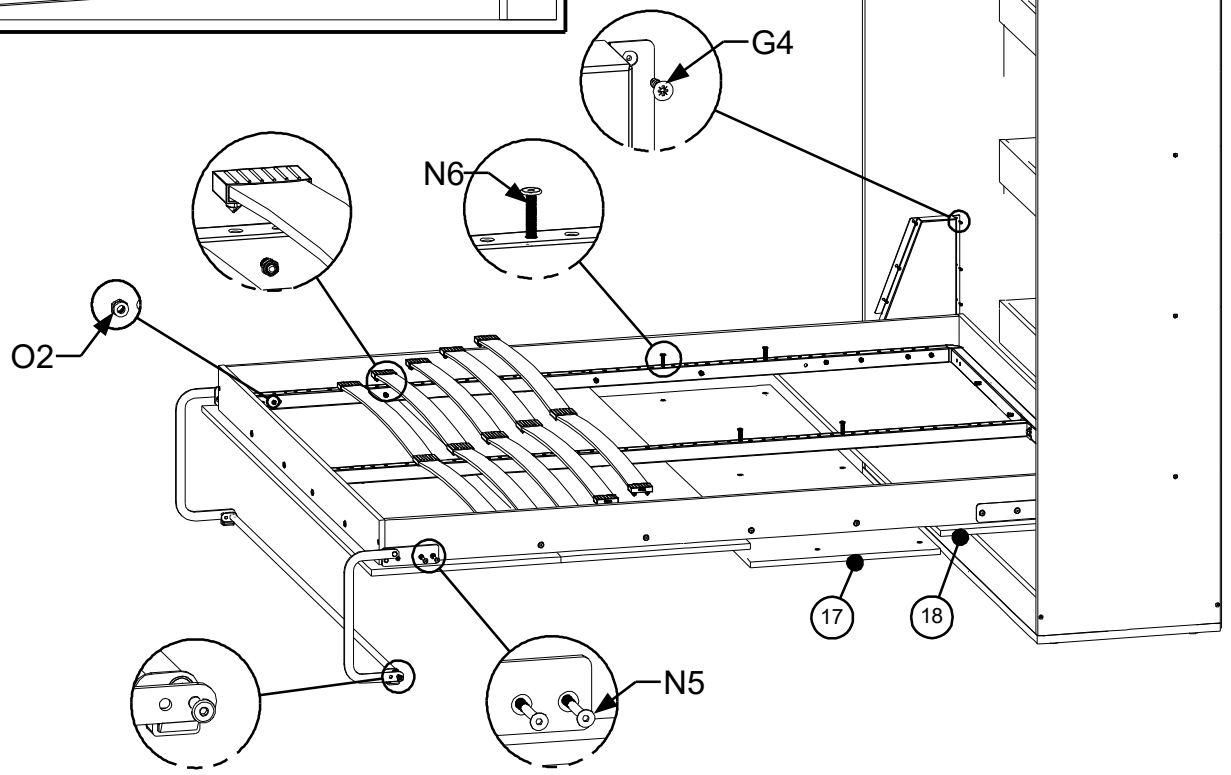
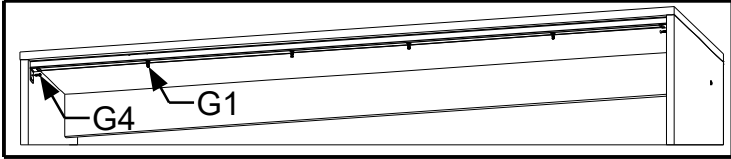

13

- G4 Ø4X16 6

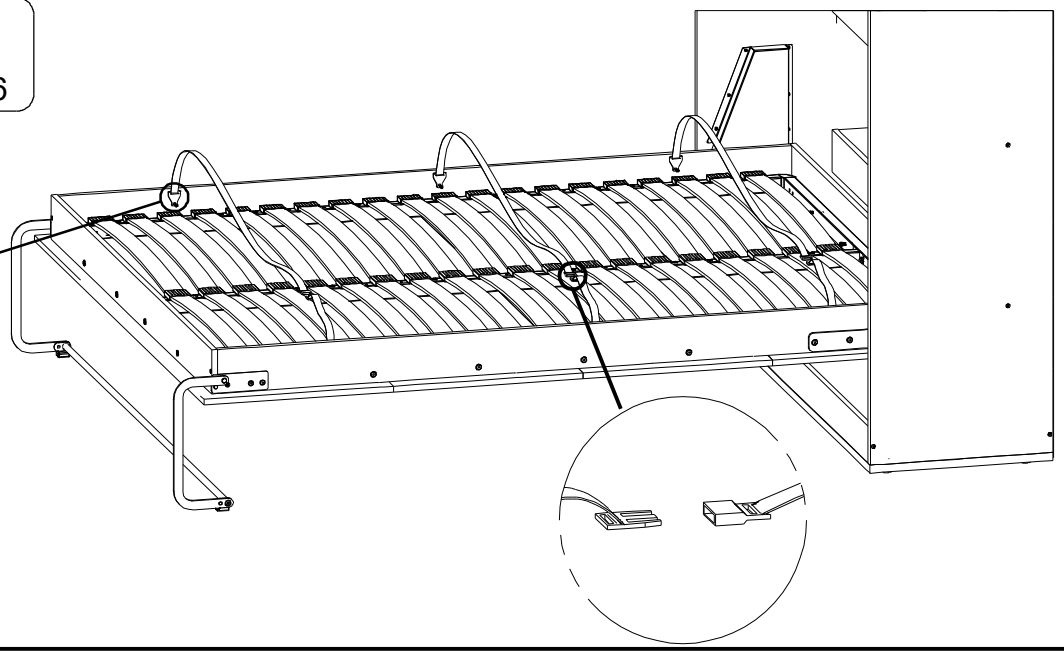
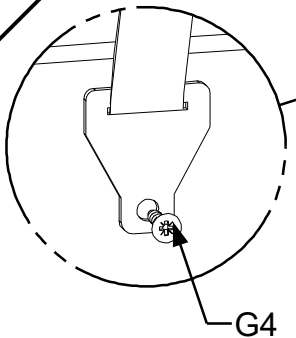



RAPILI

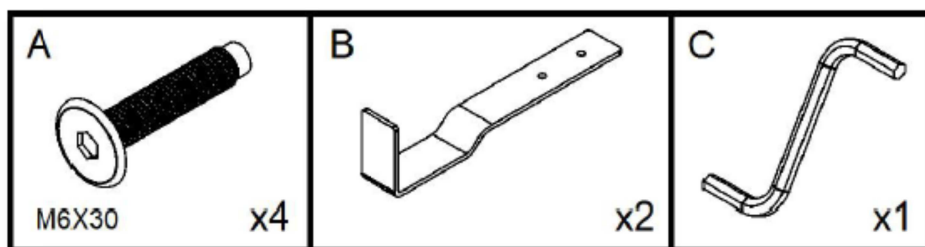
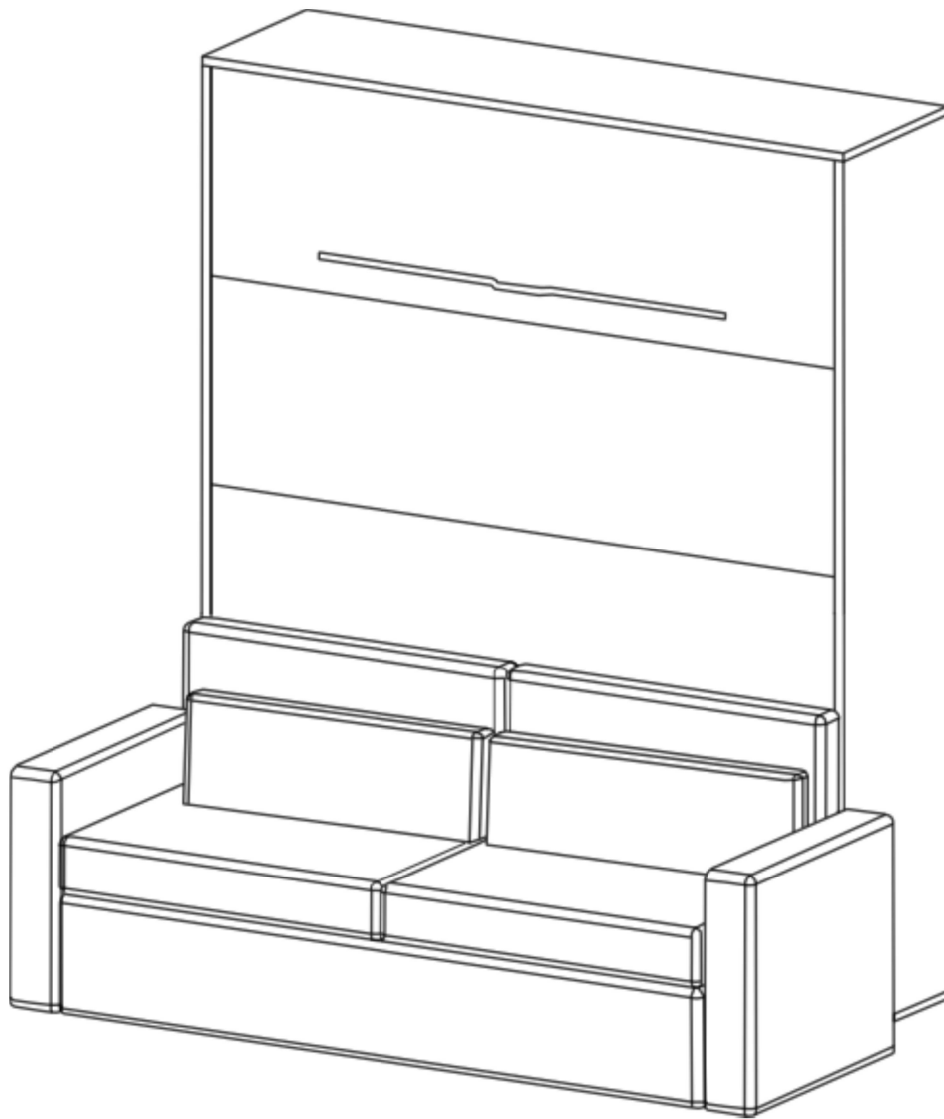

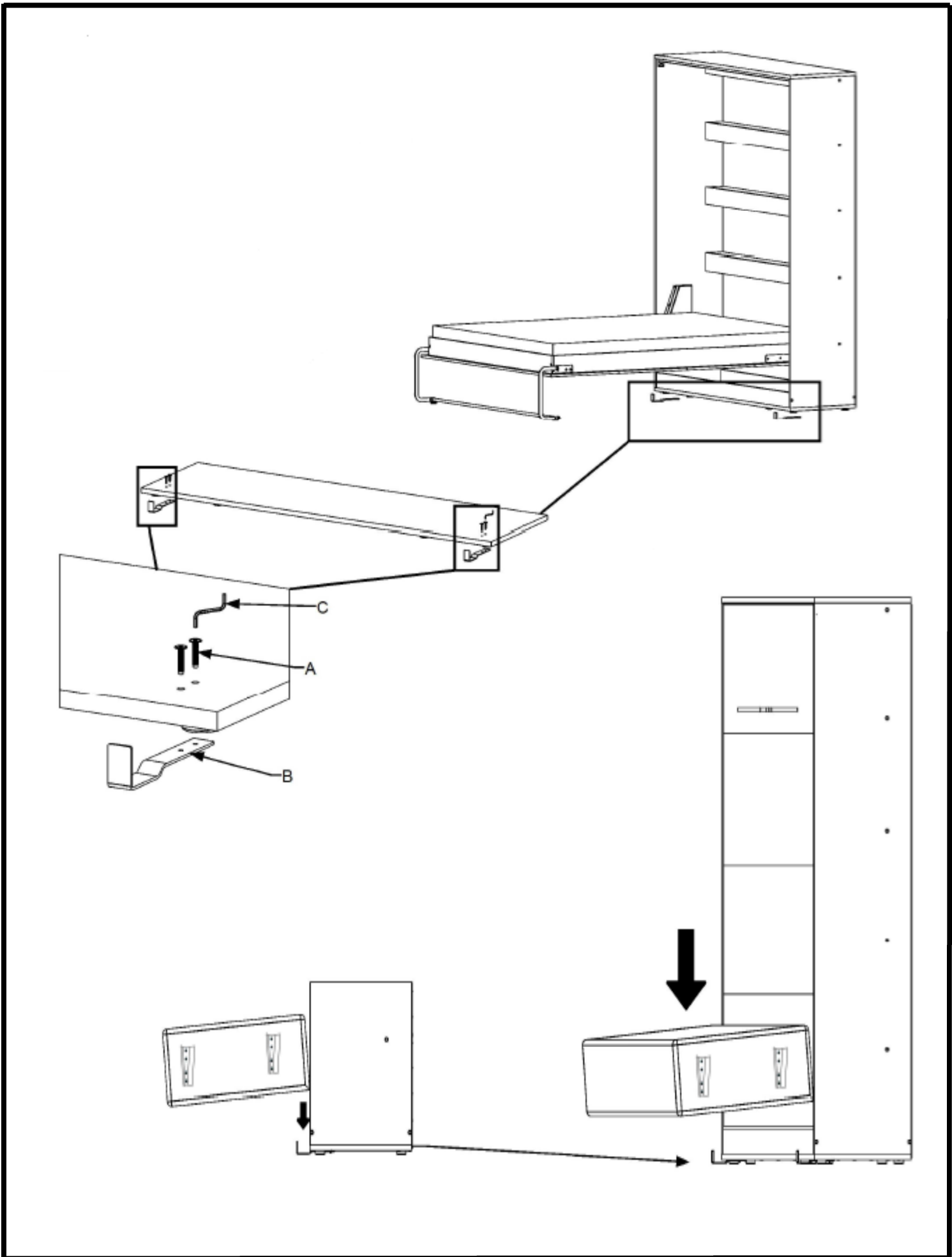

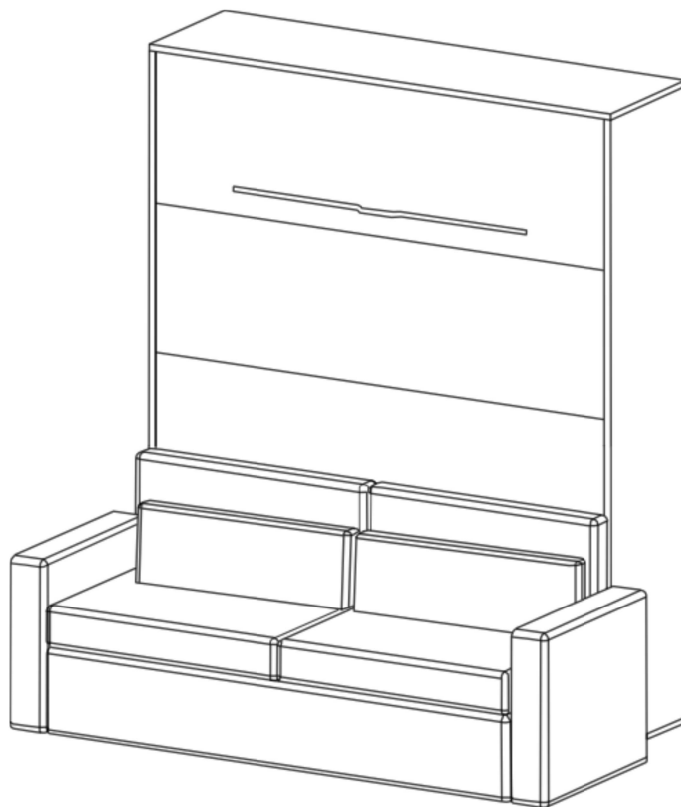
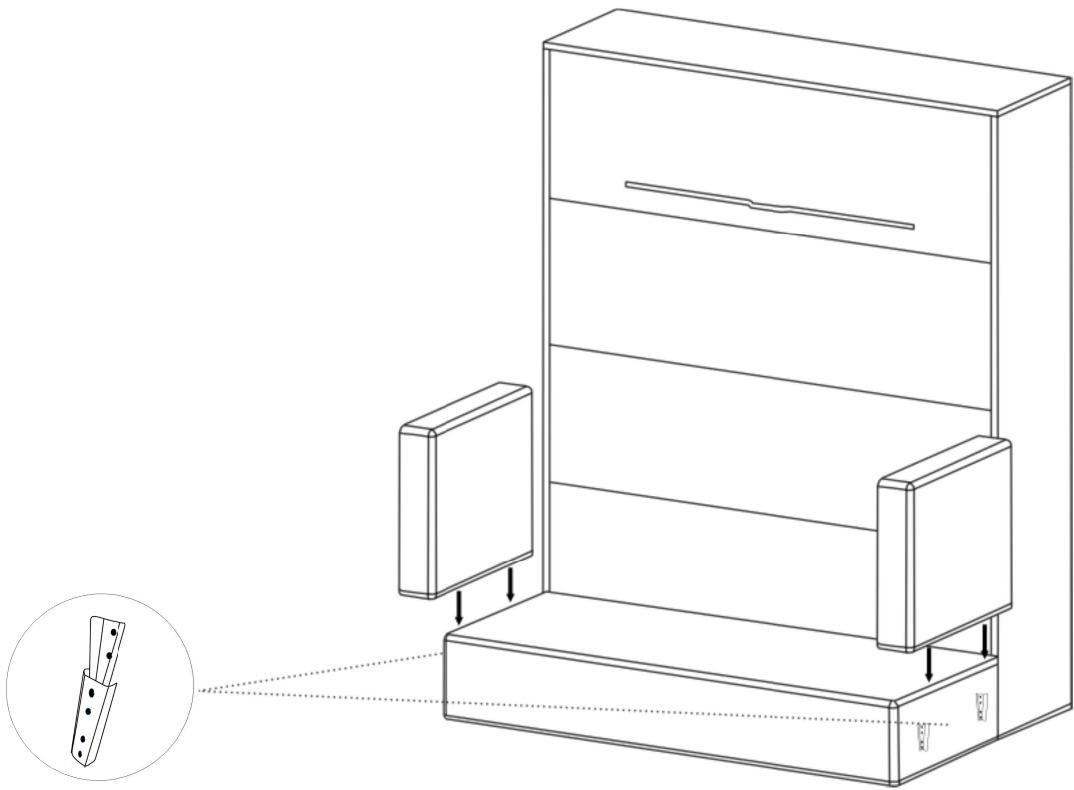

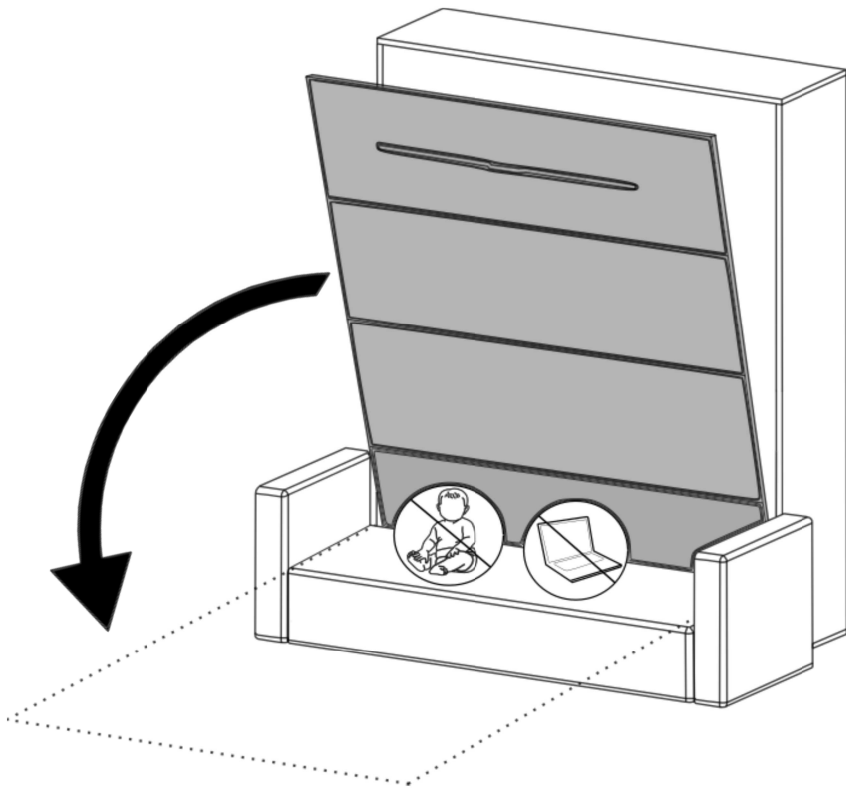
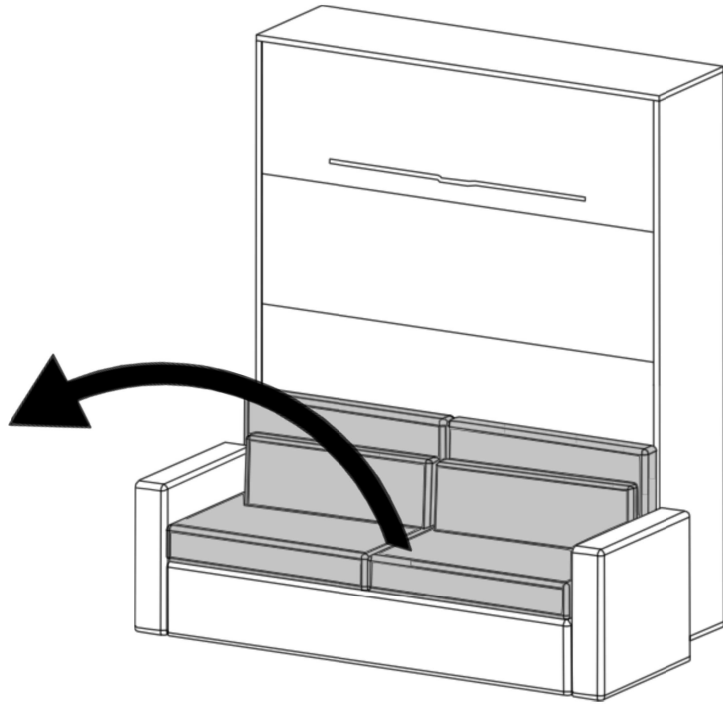

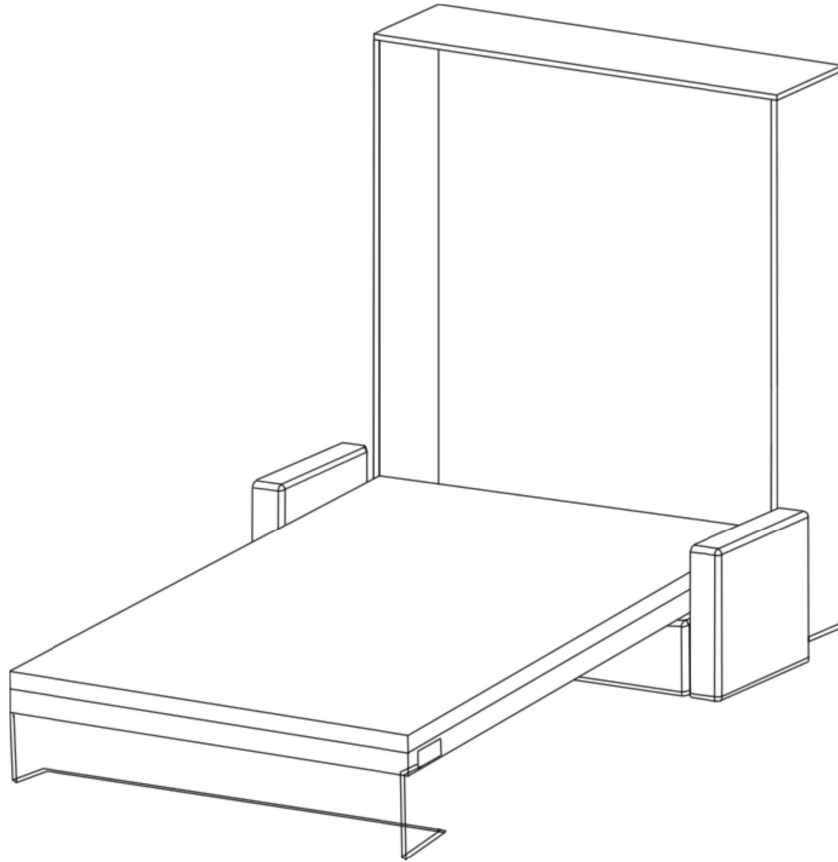

 **FR**
DONNEZ
OU
RECYCLEZ

 OU  OU  OU 

ASSOCIATION MAGASIN LIVRAISON DÉCHÈTERIE

Adresses sur quefairedemesdechets.fr









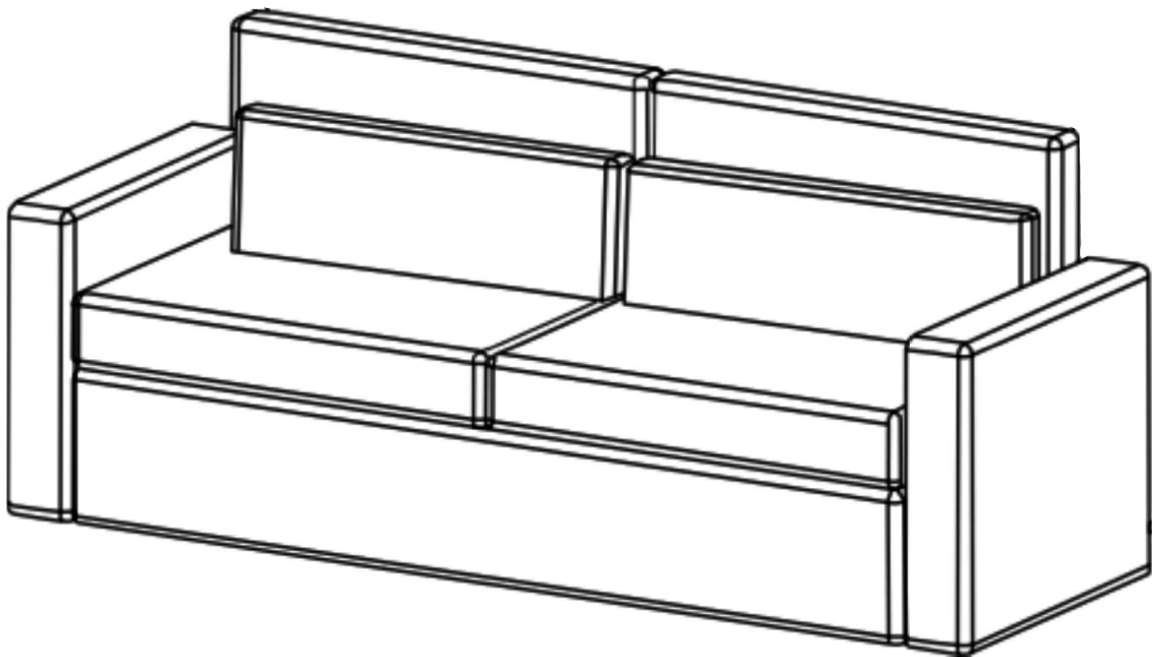

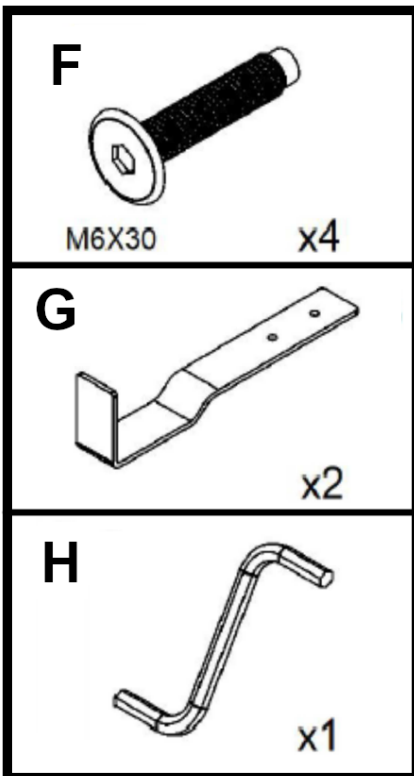
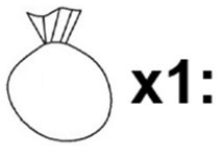
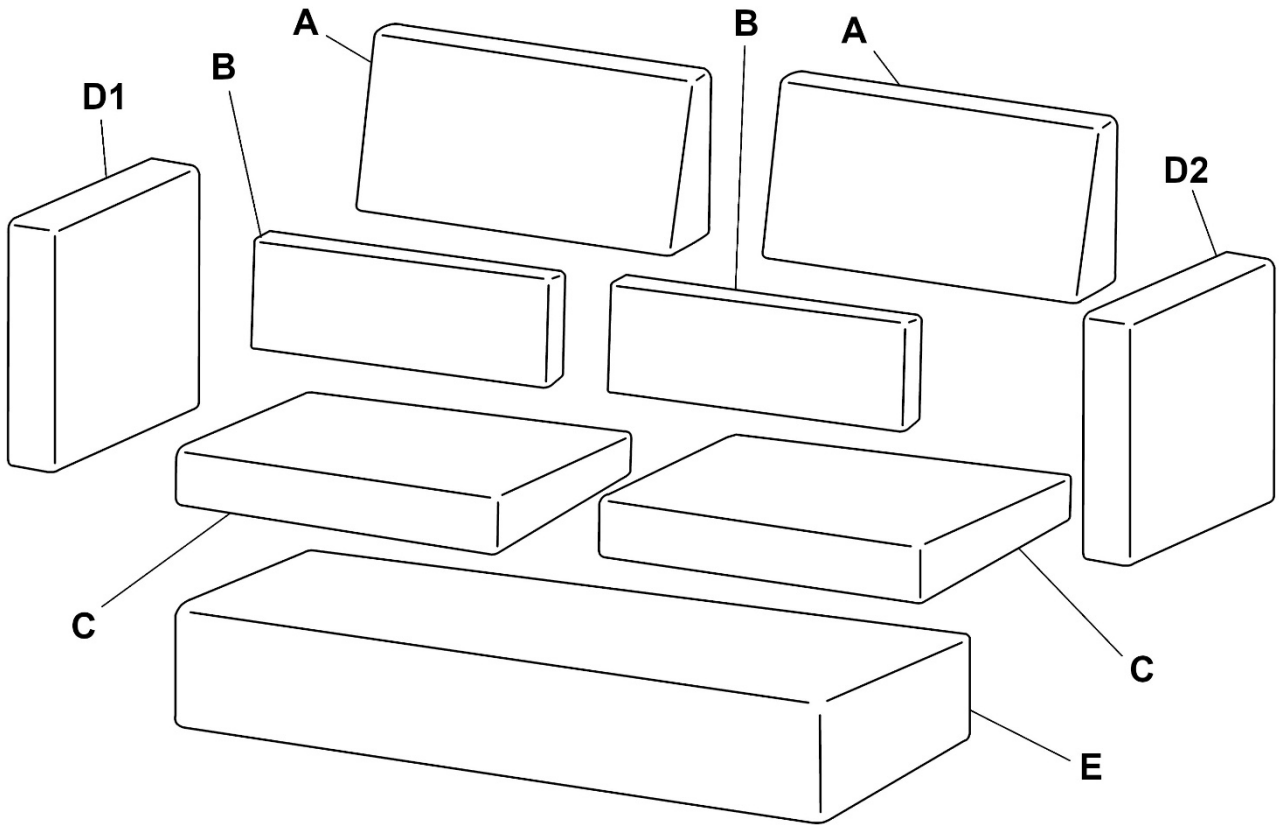
Vente-unique.com
Du bonheur à tous les étages

RAPILI

90 x 180/200 x 85 cm





A	1 
B	1 
C	1 
D1	2 
D2	2 
E	1 
	1 

INSTRUCTION DE SÉCURITÉ ET D'ENTRETIEN de CANAPÉS

EN - SAFETY AND CARE INSTRUCTION- SOFAS
DE- SICHERHEITSHINWEISE UND GEBRAUCH
VON SOFAS

ES- INSTRUCCIONES DE SEGURIDAD Y USO de
SOFÁS

POT- INSTRUÇÕES DE SEGURANÇA E
UTILIZAÇÃO DE SOFÁS

IT- ISTRUZIONI DI SICUREZZA E UTILIZZO DIVANI

NEL- VEILIGHEIDSIINSTRUCTIES EN GEBRUIK VAN
BANKEN EN HOEKBANK

POL- INSTRUKCJA BEZPIECZEŃSTWA I
UŻYTKOWANIA SOF I NAROŻNIKÓW

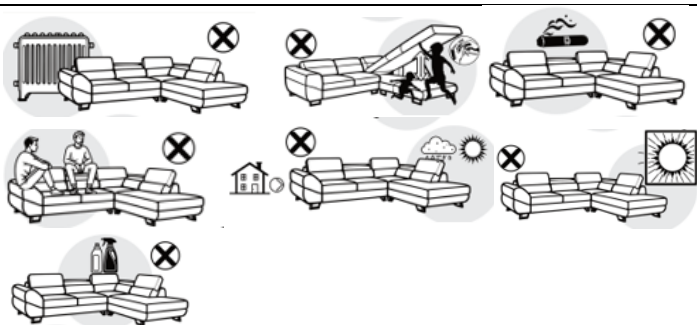

La surface doit être nettoyée avec un chiffon humide ou avec des détergents dédiés. Les déversements doivent être éliminés immédiatement avec un tampon propre et sec pour absorber le liquide. Ne frottez pas, cela pourrait endommager le tissu. Des variations de couleur entre les surfaces nettoyées et non nettoyées peuvent apparaître. En cas de doute, contactez un professionnel pour effectuer le nettoyage. Si le produit est équipé d'un composant électrique, veuillez utiliser uniquement l'alimentation fournie avec l'appareil. Il doit être alimenté uniquement avec la tension indiquée sur l'étiquette de l'appareil.

Surface shall be cleaned with moist cloth or with dedicated detergents. Spills should be removed immediately with a clean and dry dabbing to absorb the liquid. Do not rub, it may damage the fabric. Variations in color between the surfaces cleaned and uncleaned might appear. If in doubt, contact a professional to carry out cleaning. If the product is equipped with an electrical component, please use only the power supply provided with the appliance. It must only be powered with the voltage indicated on the appliance's label.

Die Oberfläche muss mit einem feuchten Tuch oder speziellen Reinigungsmitteln gereinigt werden. Verschüttete Flüssigkeiten sollten sofort mit einem sauberen und trockenen Tupfer entfernt werden, um die Flüssigkeit aufzusaugen. Nicht reiben, da dies den Stoff beschädigen könnte. Es kann zu Farbabweichungen zwischen gereinigter und ungereinigter Oberfläche kommen. Wenden Sie sich im Zweifelsfall an einen Fachmann, um die Reinigung durchführen zu lassen. Wenn das Produkt mit einem elektrischen Bauteil ausgestattet ist, verwenden Sie bitte nur die mit dem Gerät gelieferte Stromversorgung. Es darf nur mit der auf dem Etikett des Geräts angegebenen Spannung betrieben werden.

La superficie se limpiará con un paño húmedo o con detergentes específicos. Los derrames deben eliminarse inmediatamente con un paño limpio y seco para absorber el líquido. No frotar, puede dañar la tela. Pueden aparecer variaciones de color entre las superficies limpiadas y sin limpiar. En caso de duda contacta con un profesional para realizar la limpieza. Si el producto está equipado con un componente eléctrico, utilice únicamente la fuente de alimentación proporcionada con el aparato. Debe ser alimentado únicamente con la tensión indicada en la etiqueta del aparato.

A superfície deve ser limpa com pano úmido ou com detergentes específicos. Os derramamentos devem ser removidos imediatamente com um pano limpo e seco para absorver o líquido. Não esfregue, pode danificar o tecido. Podem aparecer variações de cor entre as superfícies limpas e não limpas. Em caso de dúvida, procure um profissional para realizar a limpeza. Se o produto é dotado de um componente elétrico, utilize exclusivamente a alimentação fornecida com o dispositivo. Deve ser alimentado exclusivamente com a tensão indicada sull'etichetta del dispositivo.

La superficie dovrà essere pulita con un panno umido o con detergenti dedicati. Le fuoriuscite devono essere rimosse immediatamente con un panno pulito e asciutto per assorbire il liquido. Non strofinare, potrebbe danneggiare il tessuto. Potrebbero apparire variazioni di colore tra le superfici pulite e quelle non pulite. In caso di dubbi, rivolgersi ad un professionista per effettuare la pulizia. Se o produto for equipado com um componente elétrico, utilize apenas a fonte de alimentação fornecida com o aparelho. Deve ser alimentado apenas com a voltagem indicada no rótulo do aparelho.

Het oppervlak moet worden gereinigd met een vochtige doek of met speciale reinigingsmiddelen. Gemorste vloeistoffen moeten onmiddellijk worden verwijderd door schoon en droog te deppen om de vloeistof te absorberen. Niet wrijven, dit kan de stof beschadigen. Er kunnen kleurvariaties optreden tussen de gereinigde en onverrengde oppervlakken. Neem bij twijfel contact op met een professional om de reiniging uit te voeren. Als het product is uitgerust met een elektrisch onderdeel, gebruik dan alleen de voeding die bij het apparaat wordt geleverd. Het moet alleen worden gevoed met de spanning die op het etiket van het apparaat staat aangegeven.

Powierzchnię należy czyścić wilgotną szmatką lub specjalnymi detergentami. Rozlane ciecze należy natychmiast usunąć czystym i suchym przetarciem, aby wchłoniąć płyn. Nie trzyj, może to spowodować uszkodzenie tkaniny. Mogą pojawić się różnice w kolorze pomiędzy powierzchniami oczyszczonymi i nieoczyszczonymi. W razie wątpliwości należy skontaktować się ze specjalistą w celu przeprowadzenia czyszczenia. Nie usuwaj systemu blokady szuflad. Jeśli produkt wyposażony jest w komponent elektryczny, używaj wyłącznie zasilania dostarczonego z urządzeniem. Musi być zasilany wyłącznie napięciem wskazanym na etykiecie urządzenia.

1.

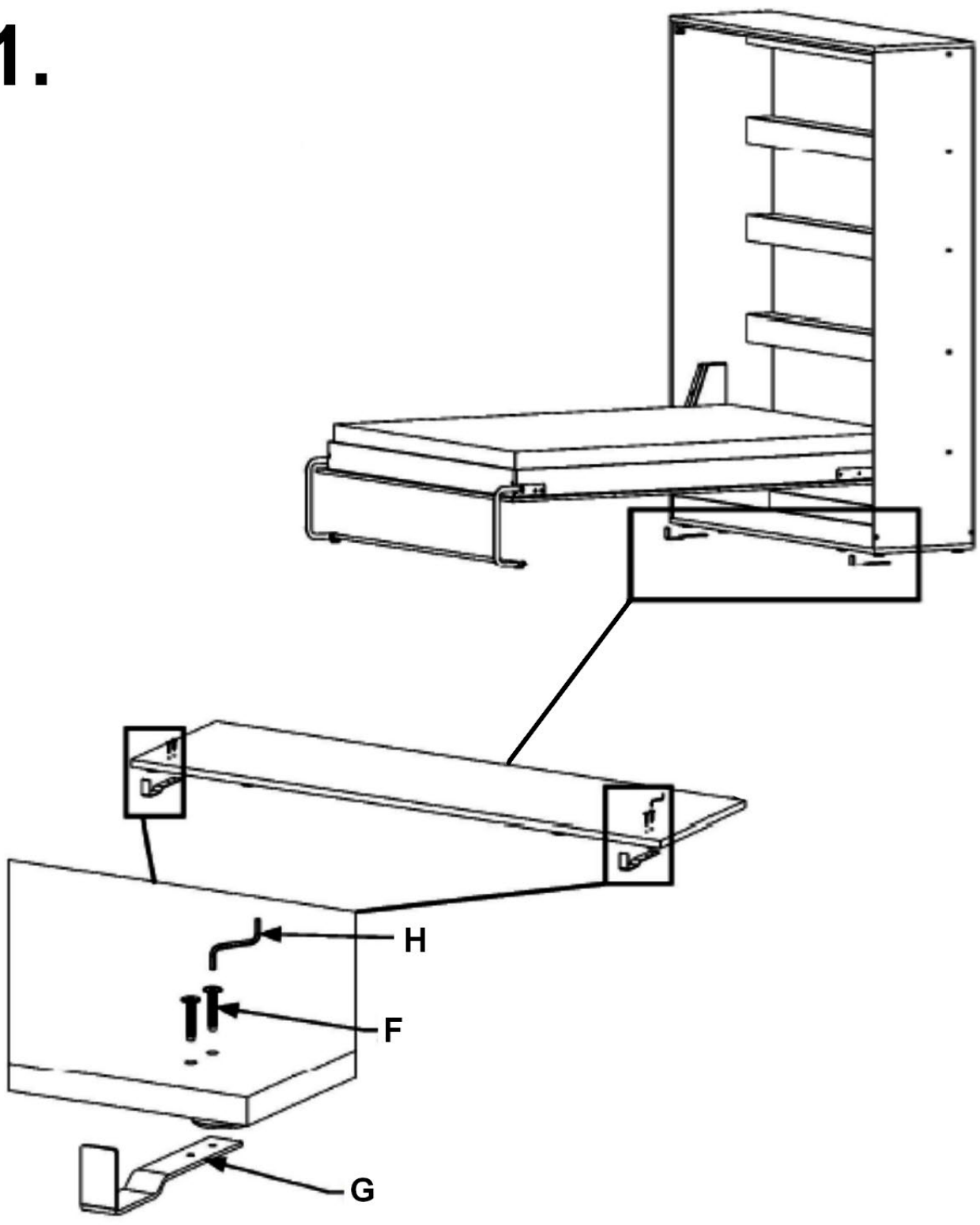

2.

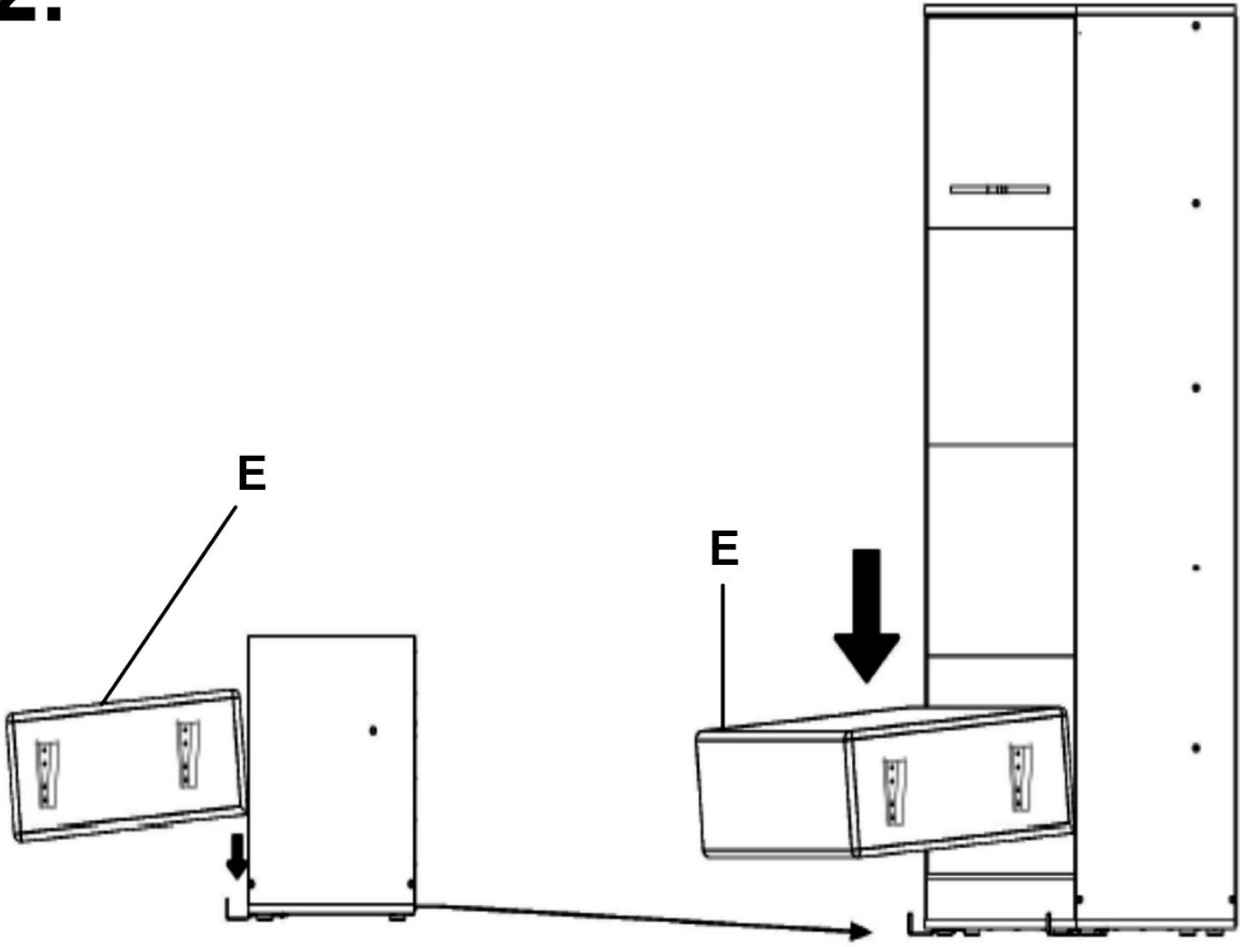

3.

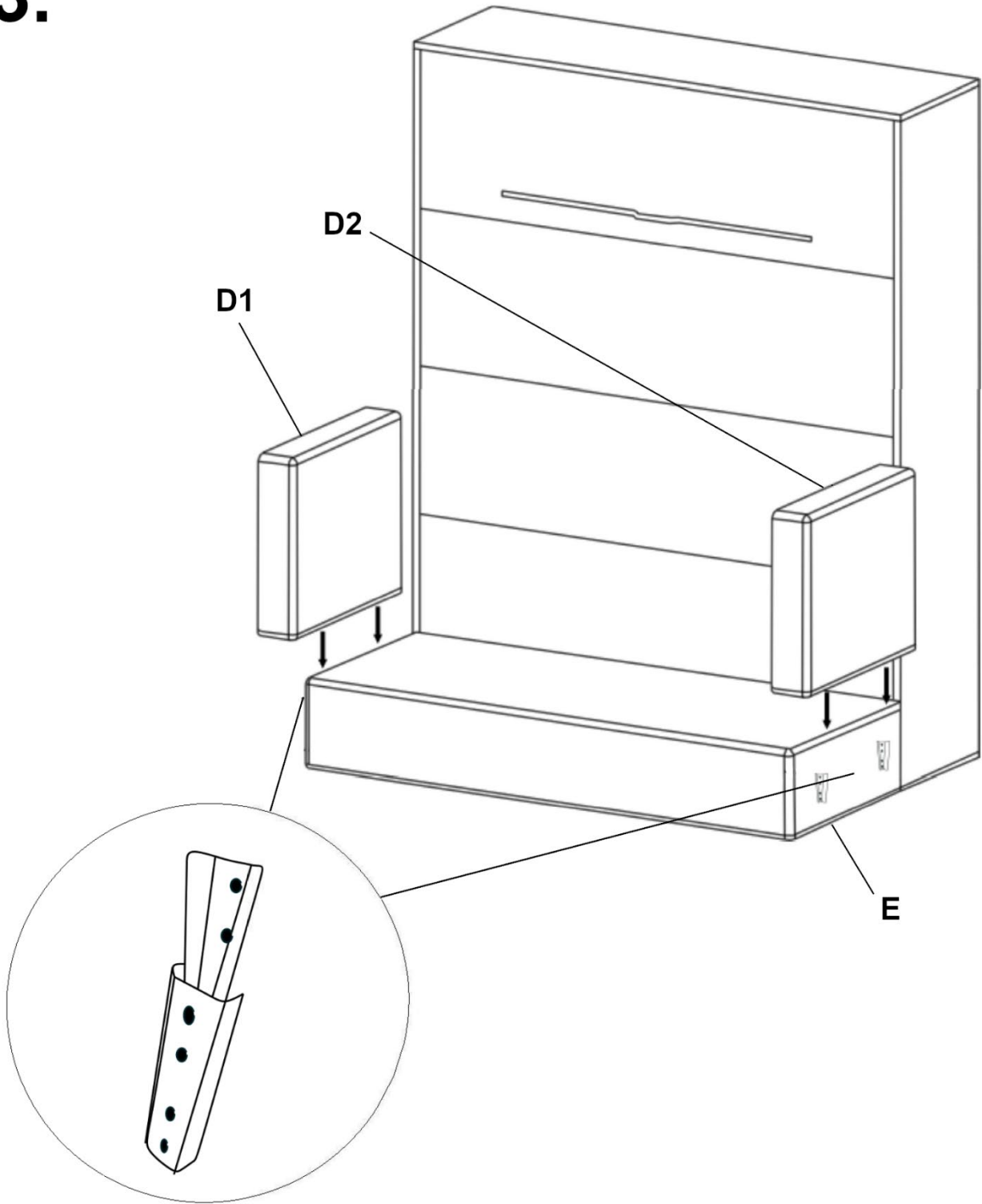

4.

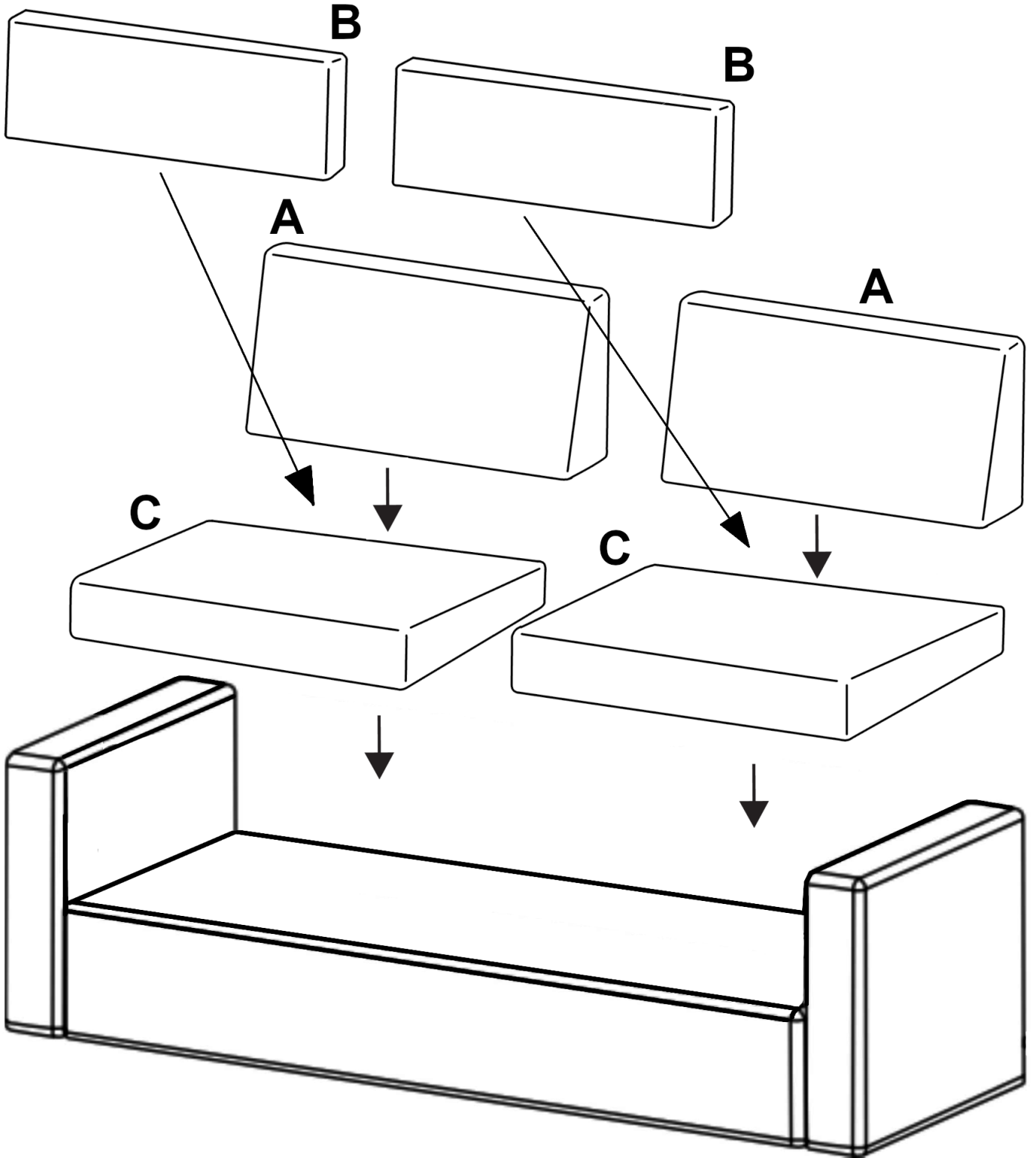

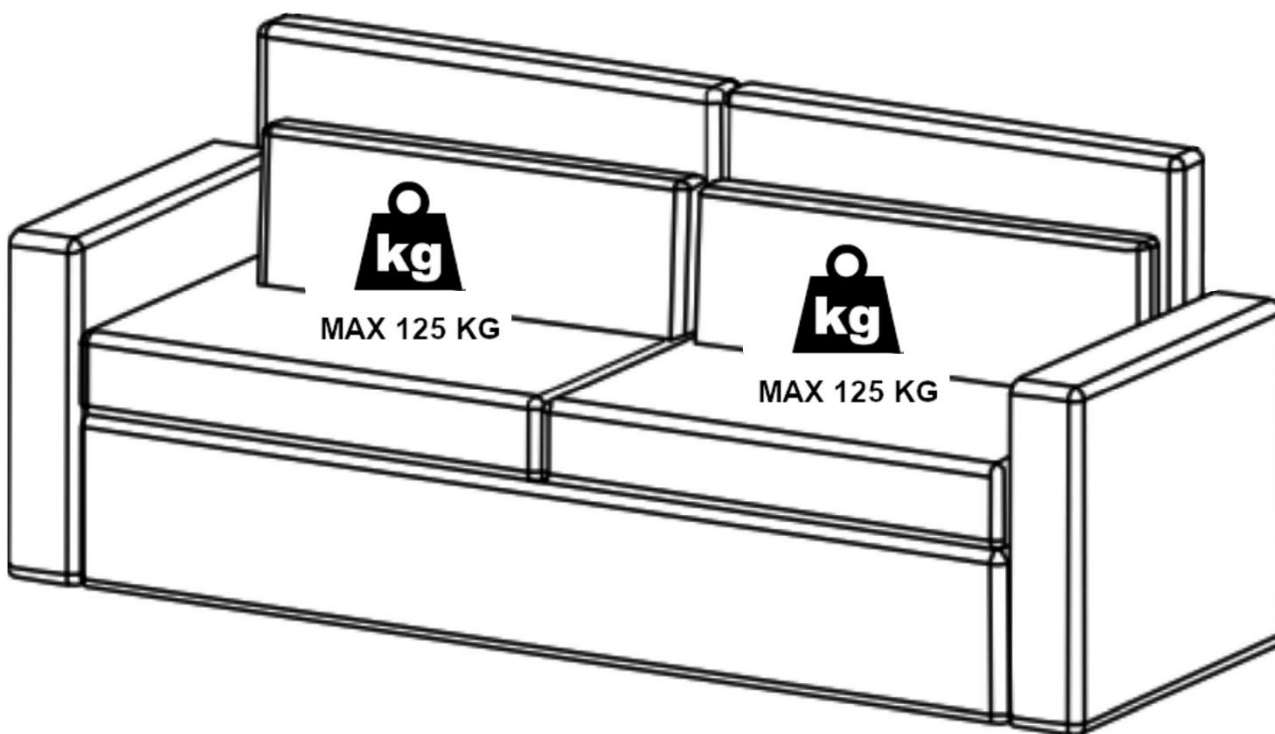

Importe par- Imported by- Importiert von- Importado por- Importato da- Geïmporteerd door-
Importado por- Importowane przez :

VENTE-UNIQUE.COM

9 Rue Jacquart 93310 Le Pré-Saint-Gervais

gpsr@vente-unique.com

Fabriqué en Pologne/ Made in Poland/ Hergestellt in Polen/ Hecho en Polonia/ Prodotto in Polonia/
Gemaakt in Polen/ Feito na Polônia/ Wyprodukowano w Polsce

