

Manuel d'instructions/Instruction Manual/Bedienungsanleitung/
Manual de instrucciones/Manuale di istruzioni/Handleiding/
Manual de instruções/Instrukcja obsługi

BAZIO

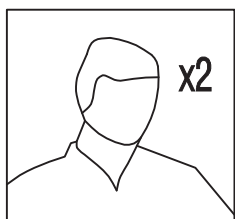

x2

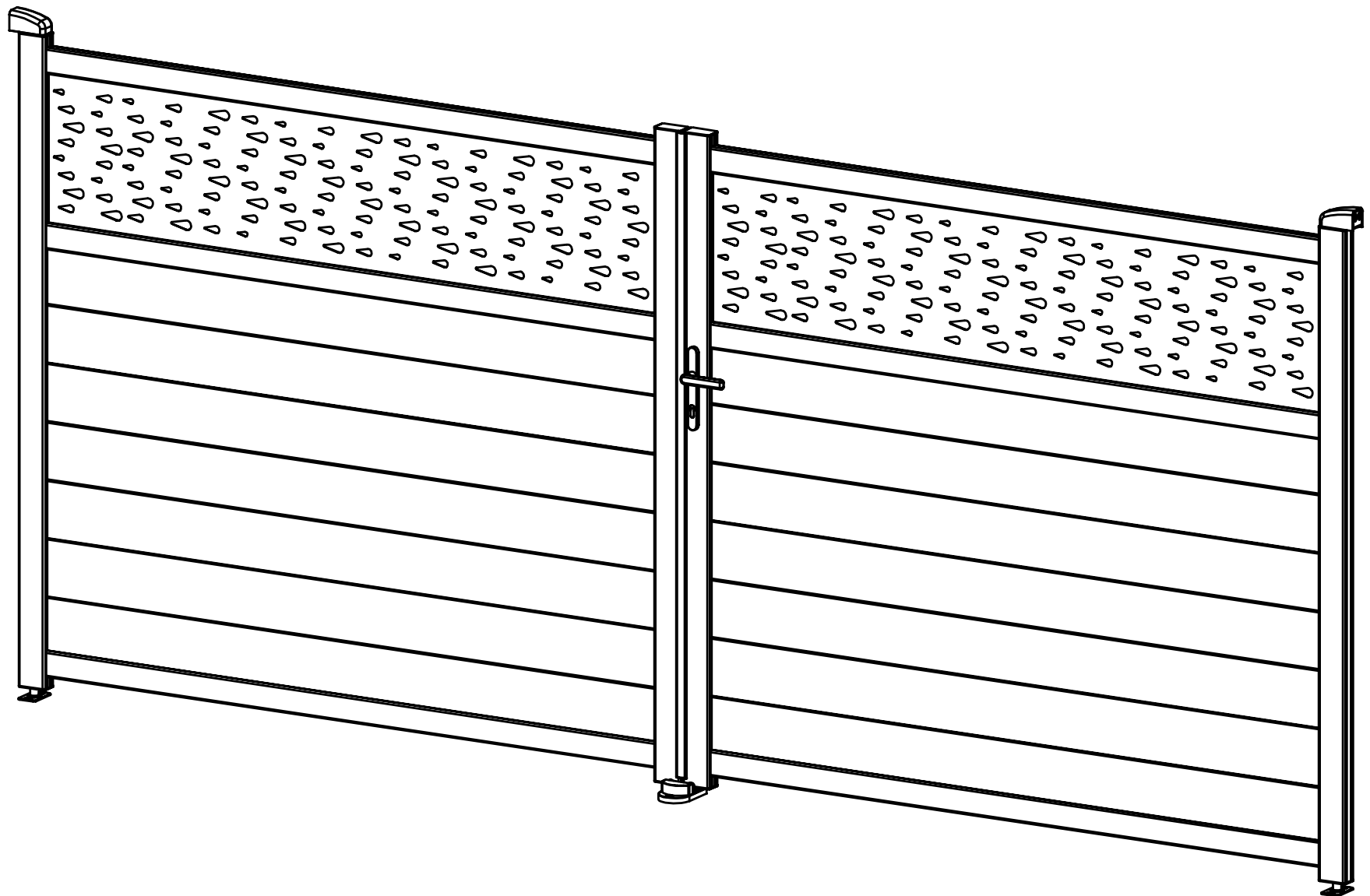
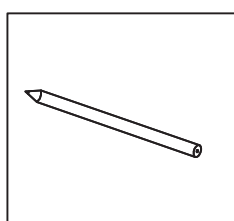
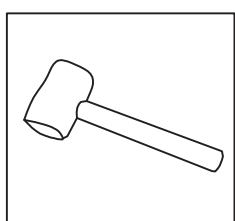
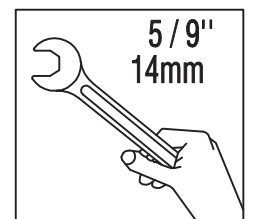
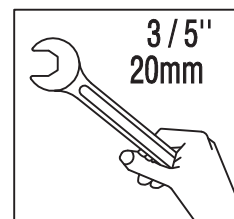
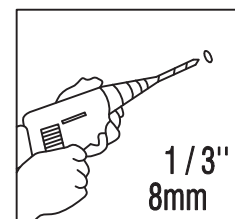
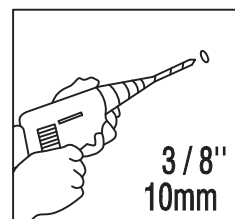
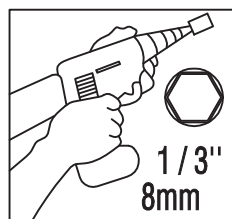
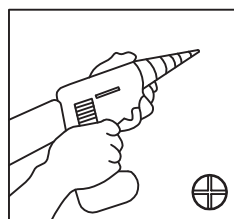
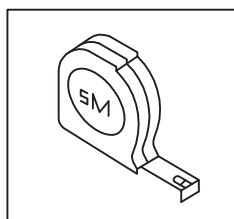

Porte en aluminium
Mina B-F

! AVERTISSEMENT: nécessite un entretien rapide pour s'assurer que la construction est solide.

! WARNING: Need timely maintenance to make sure construction is strong.

! WARNUNG: Sie müssen rechtzeitig gewartet werden, um sicherzustellen, dass die Konstruktion stark ist.

! ADVERTENCIA: Necesita un mantenimiento oportuno para asegurarse de que la construcción sea sólida.

! AVVERTENZA: è necessaria una manutenzione tempestiva per assicurarsi che la costruzione sia robusta.

! WAARSCHUWING: Heeft tijdig onderhoud nodig om ervoor te zorgen dat de constructie sterk is.

! AVISO: Precisa de manutenção oportuna para garantir que a construção seja forte.



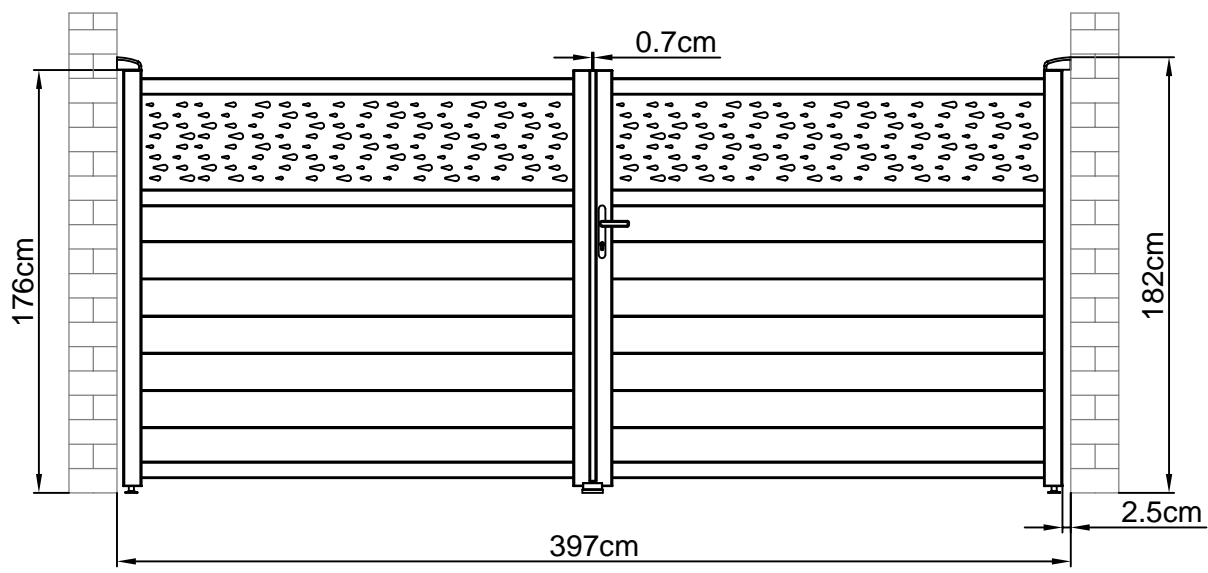

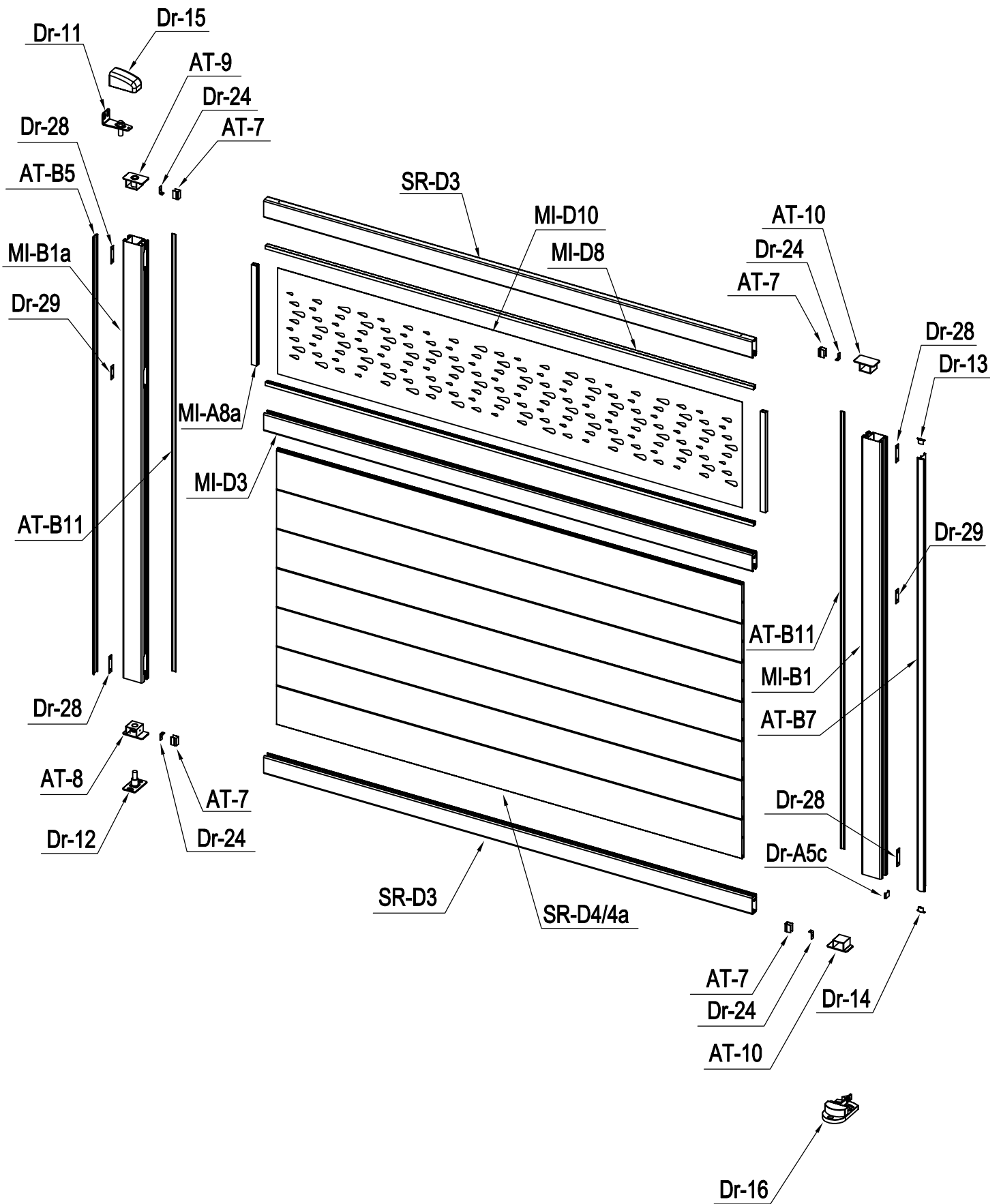

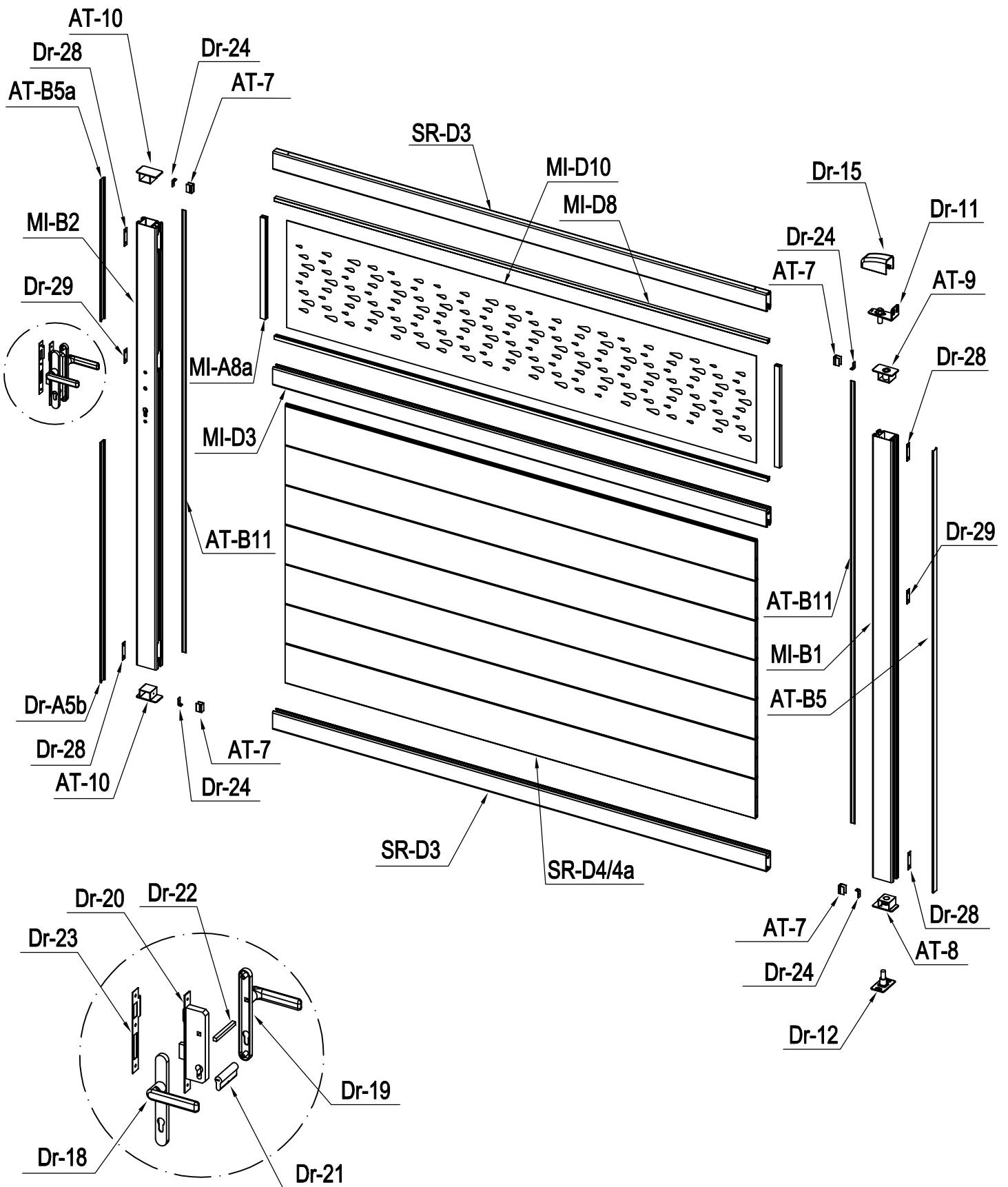











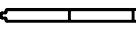



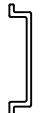



















! OSTRZEŻENIE: Potrzebujesz terminowej konserwacji, aby upewnić się, że konstrukcja jest silna.











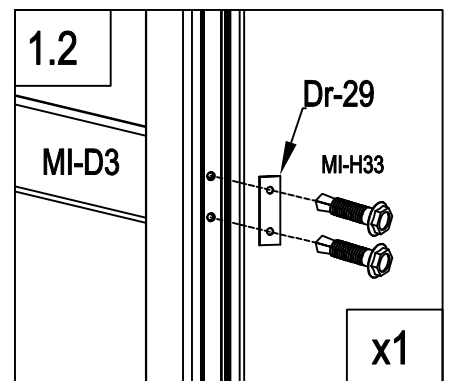
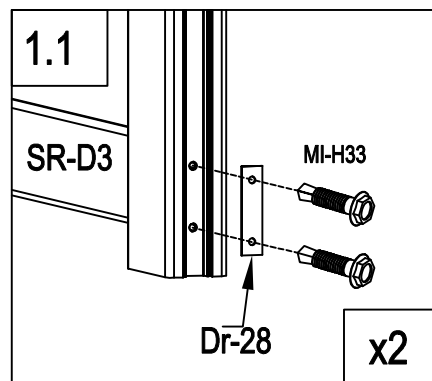
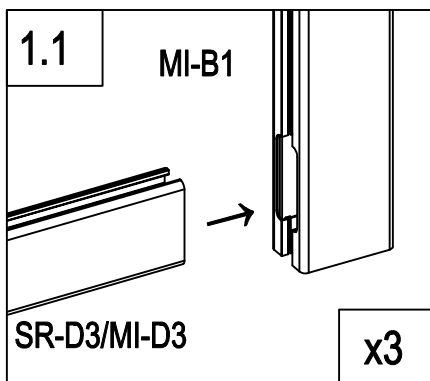
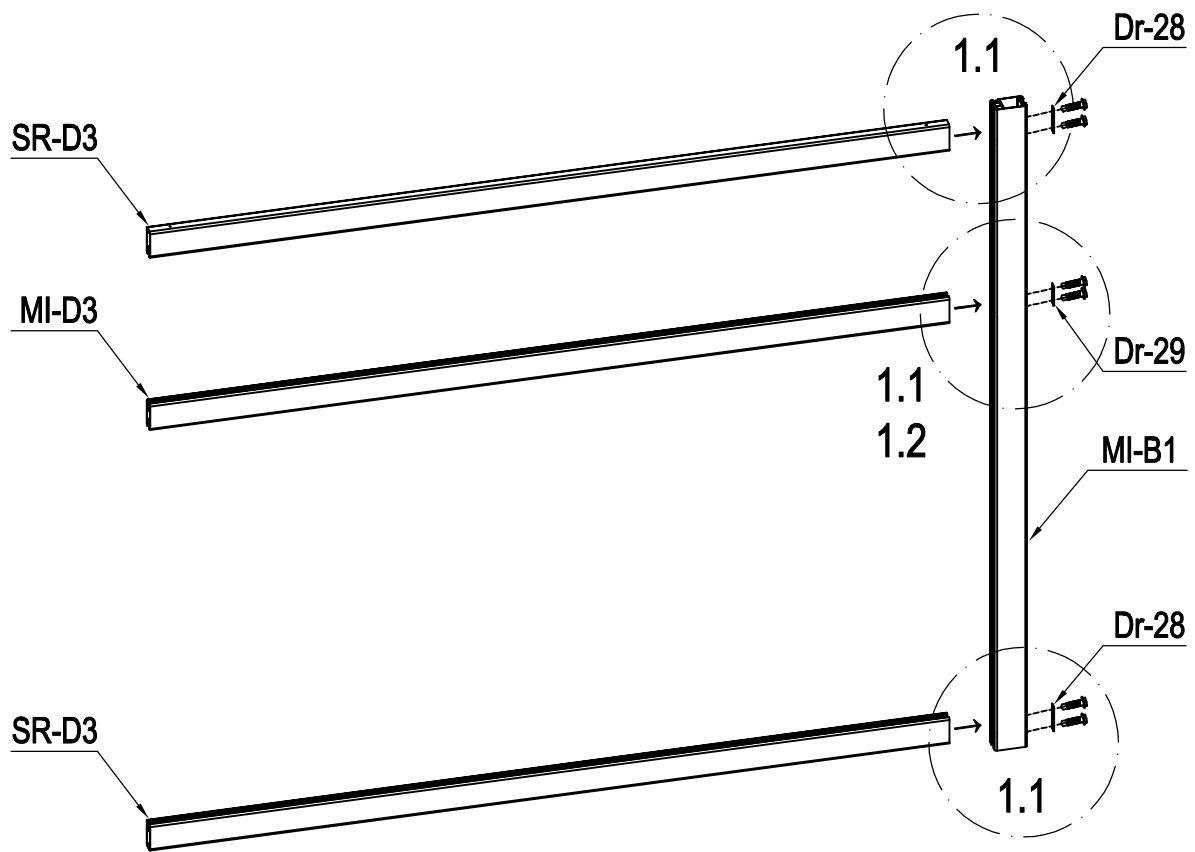

PART LIST

IMAGE	NO.	L.(mm)	QTY	Box No	IMAGE	NO.	L.(mm)	QTY	Box No
	MI-B1	1728	2	1/4		Dr-19		1	1/4
	MI-B1a	1728	1	1/4		Dr-20		1	1/4
	MI-B2	1728	1	1/4		Dr-21		1	1/4
	SR-D3	1931	4	1/4		Dr-22		1	1/4
	MI-D3	1931	2	3/4		Dr-23		1	1/4
	SR-D4	1840	12	2/4		Dr-24		8	1/4
	SR-D4a (+SR-D15)	1840	2	3/4		Dr-25		1	1/4
	AT-B5	1728	2	1/4		Dr-25a		2	1/4
	AT-B5a	550.5	1	1/4		Dr-26		3	1/4
	Dr-A5b	937	1	1/4		Dr-27		2	1/4
	Dr-A5c	19.5	1	1/4		Dr-28		8	1/4
	AT-B11	1728	4	1/4		Dr-29		4	1/4
	AT-7	29.5	8	1/4		MI-H30		8	1/4
	AT-B7	1708	1	1/4		MI-H31		8	1/4
	MI-D8	1930	4	3/4		MI-H32		12	1/4
	MI-A8a	395	4	3/4		MI-H33		24	1/4
	MI-D10	1837	2	4/4		MI-H34		3	1/4
	AT-8		2	1/4		MI-H35		3	1/4
	AT-9		2	1/4		MI-H36		68	1/4
	AT-10		4	1/4					
	Dr-11		2	1/4					
	Dr-12		2	1/4					
	Dr-13		1	1/4					
	Dr-14		1	1/4					
	Dr-15		2	1/4					
	Dr-16		1	1/4					
	Dr-17		2	1/4					
	Dr-31		4	1/4					
	Dr-18		1	1/4					



	MI-B1	1
	SR-D3	2
	MI-D3	1
	Dr-28	2

	Dr-29	1
	MI-H33	6

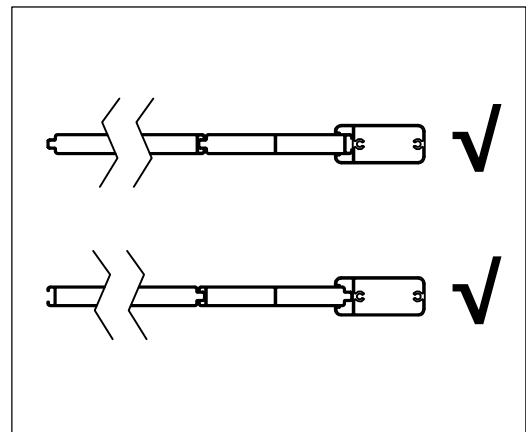
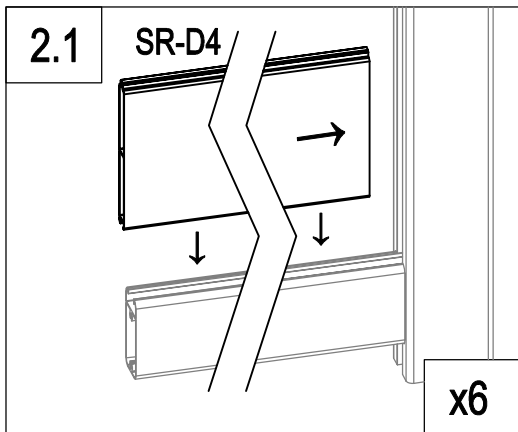
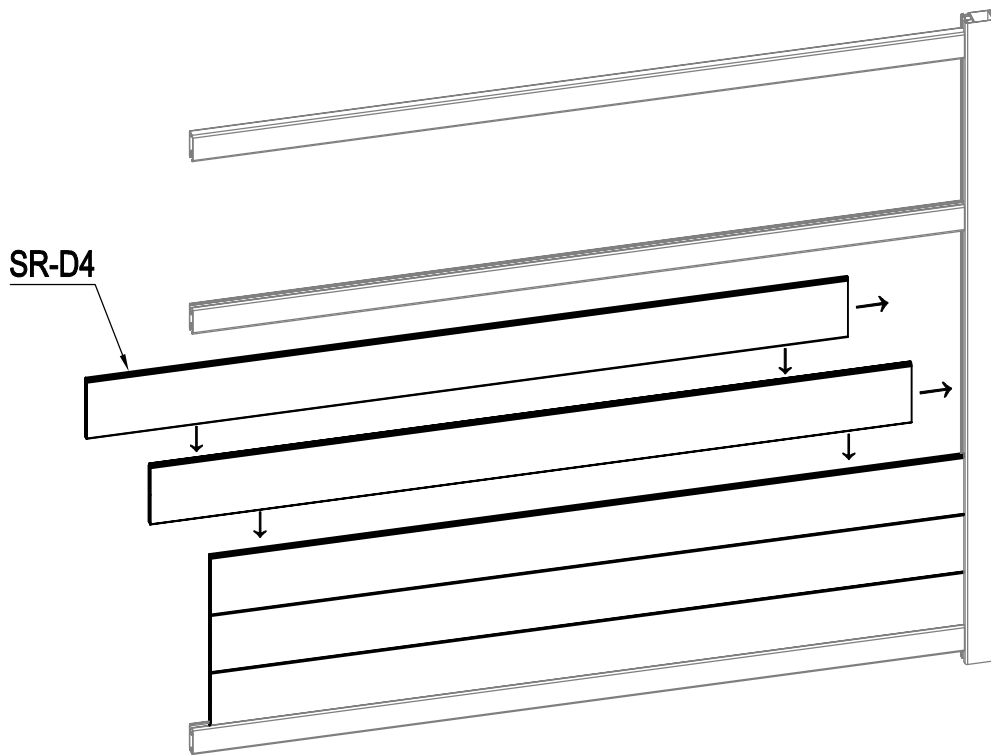

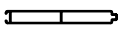

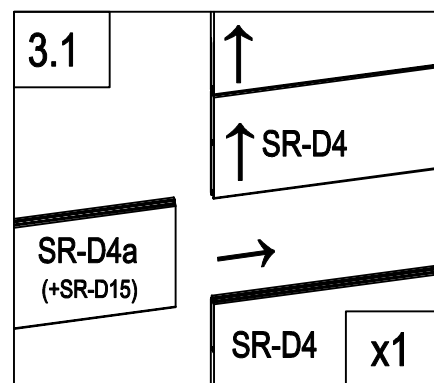
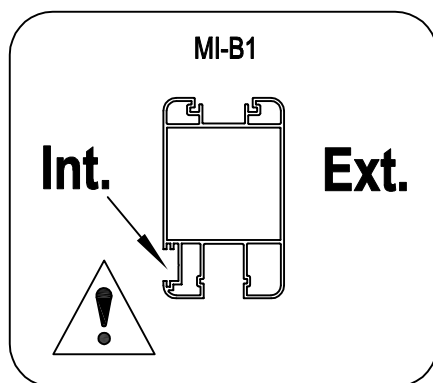
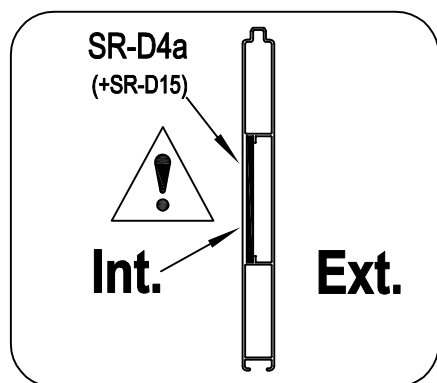
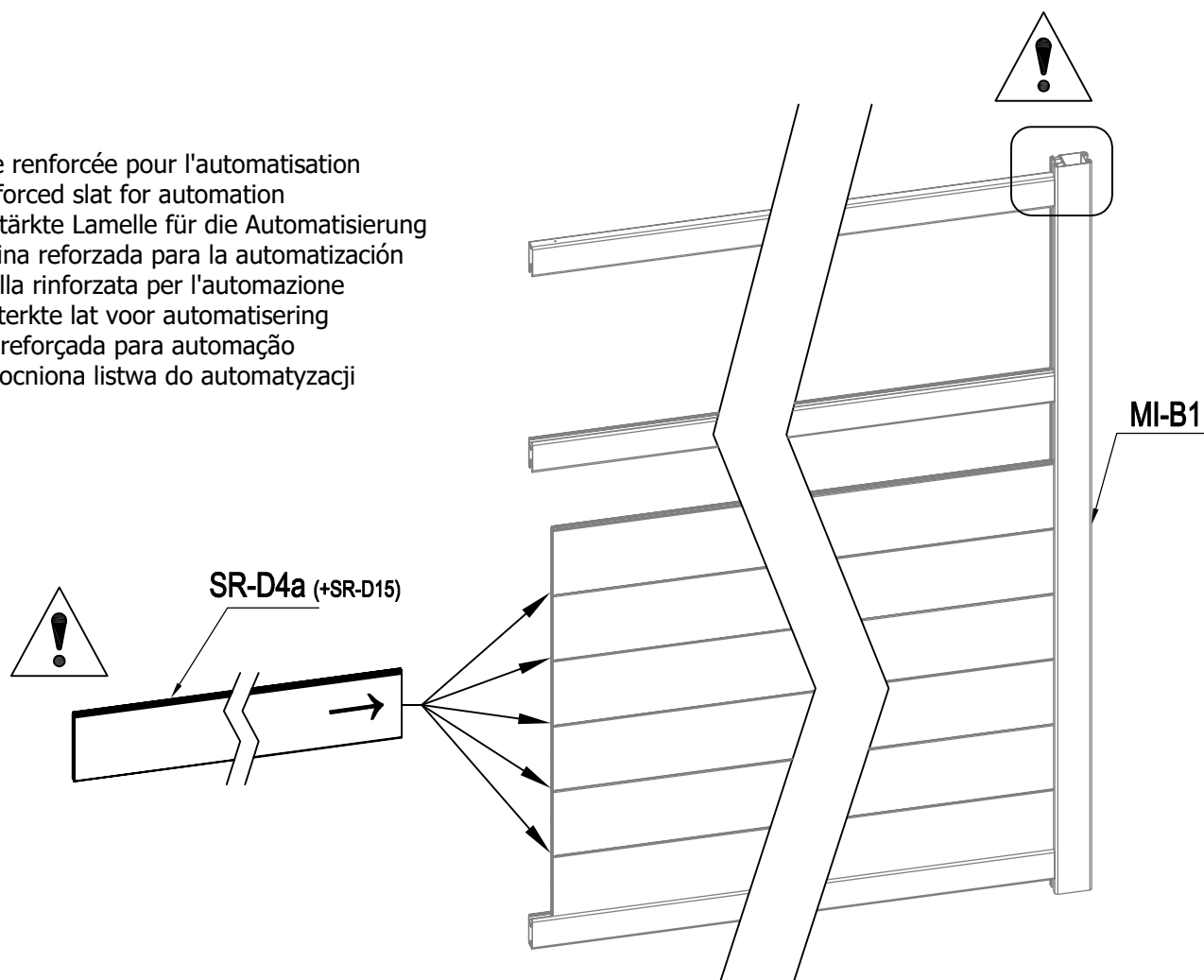

	SR-D4	6
---	-------	---

FR: lame renforcée pour l'automatisation
 EN: reinforced slat for automation
 DE: verstärkte Lamelle für die Automatisierung
 ES: Lámina reforzada para la automatización
 IT: lamella rinforzata per l'automazione
 NL: versterkte lat voor automatisering
 PT: ripa reforçada para automação
 PL: wzmocniona listwa do automatyzacji

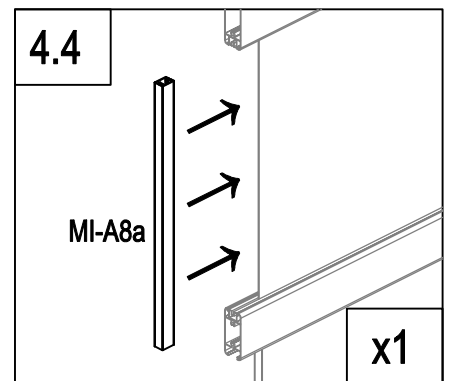
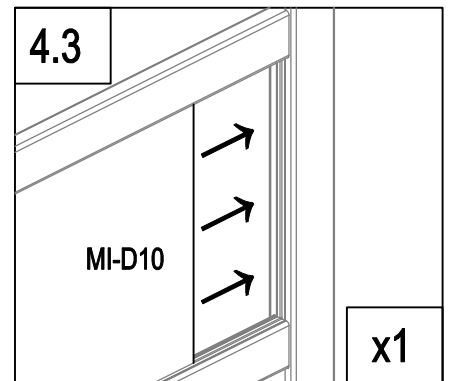
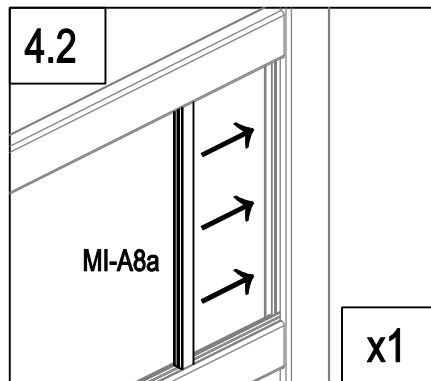
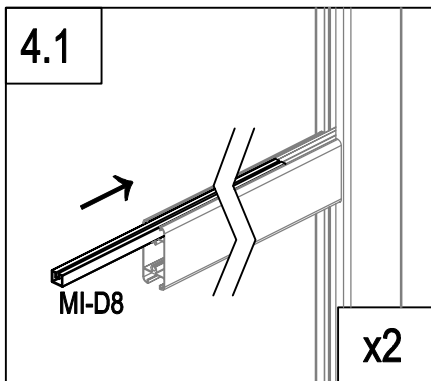
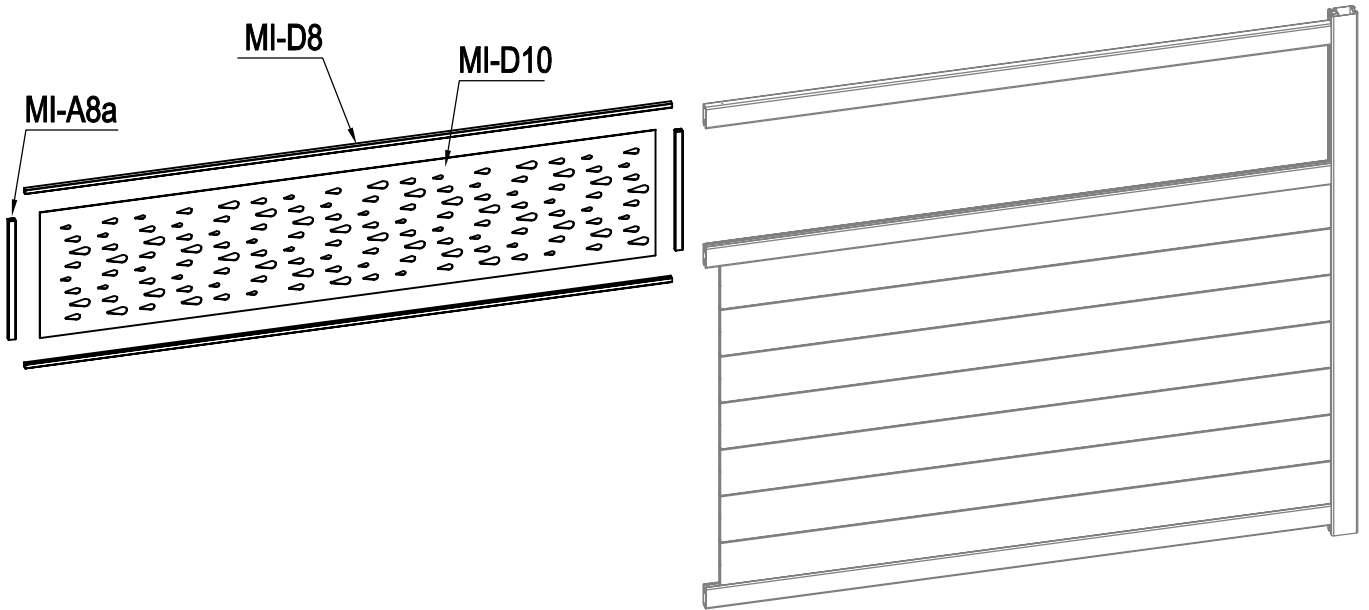





	SR-D4a (+SR-D15)	1
---	------------------	---

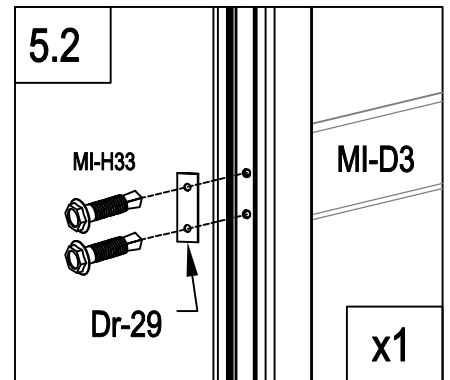
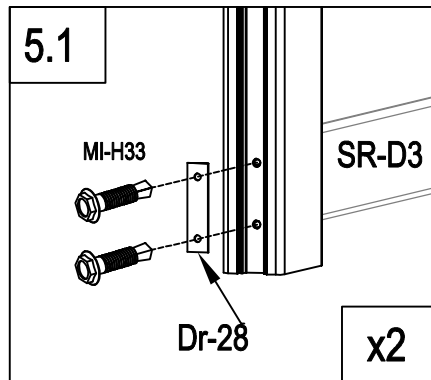
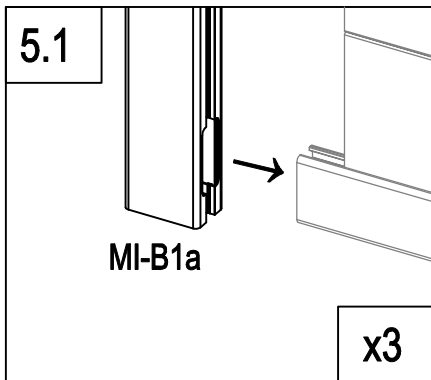
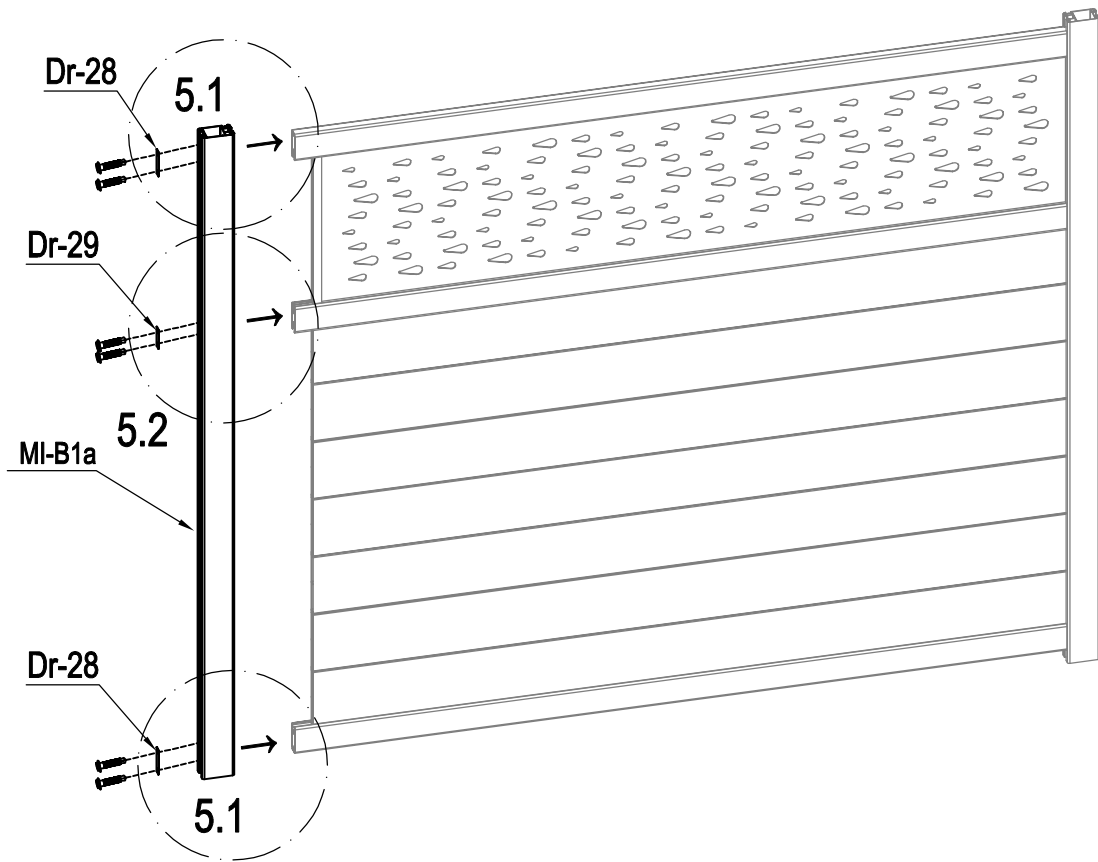

	MI-D8	2
	MI-A8a	2
	MI-D10	1



	MI-B1a	1
	Dr-28	2
	Dr-29	1
	MI-H33	6

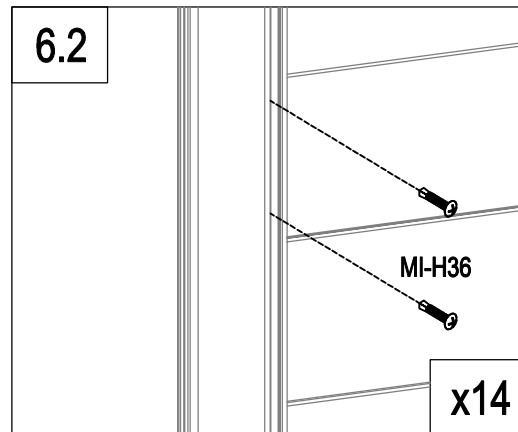
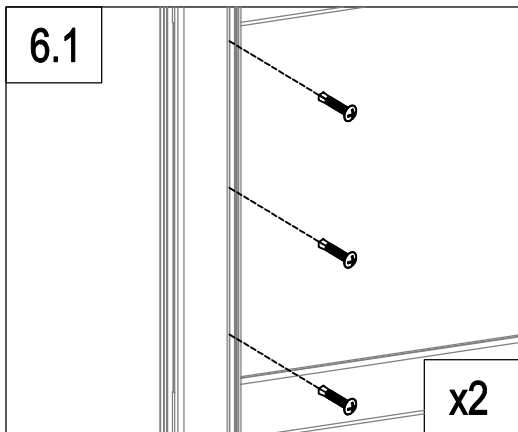
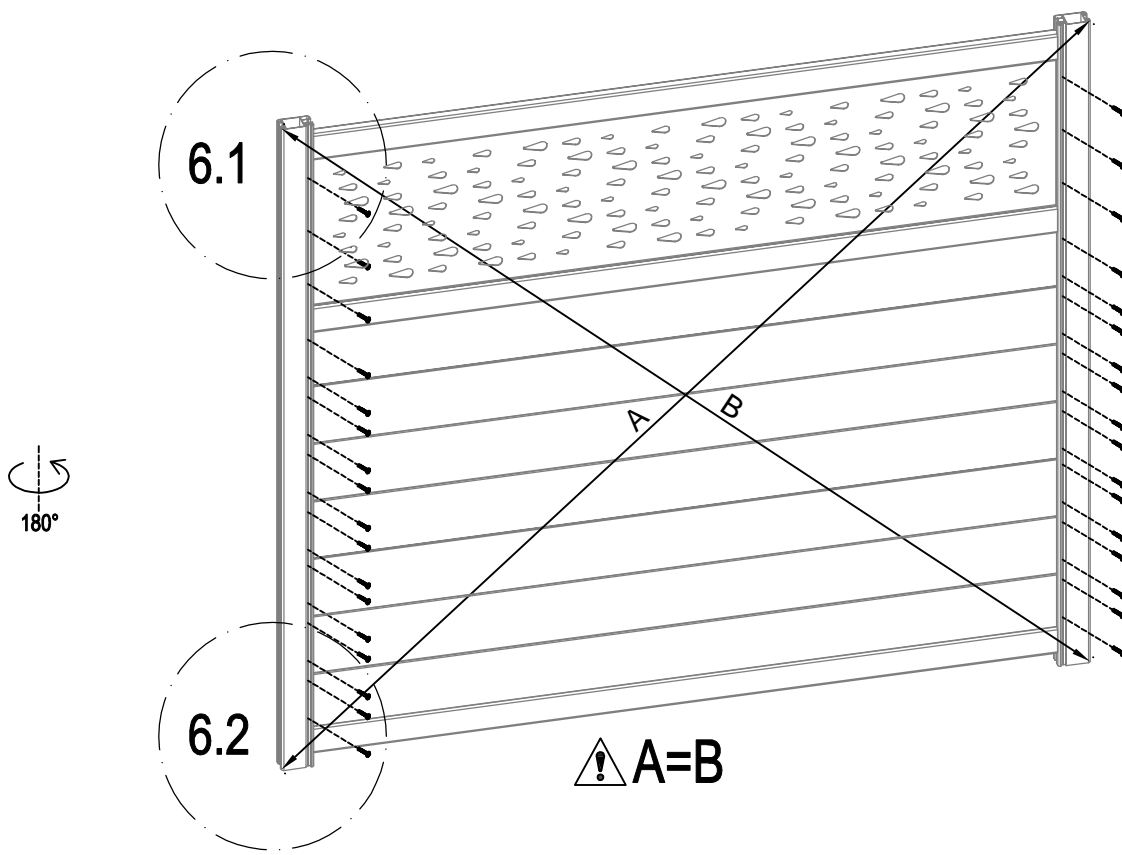

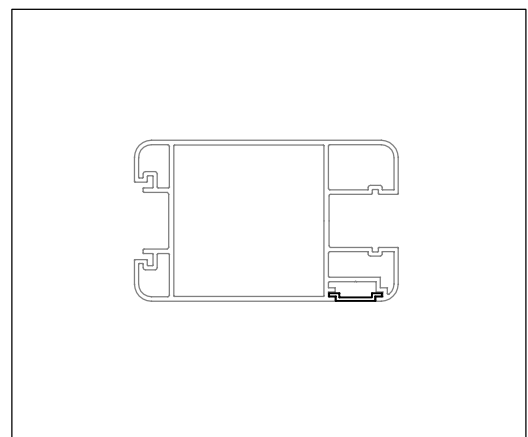
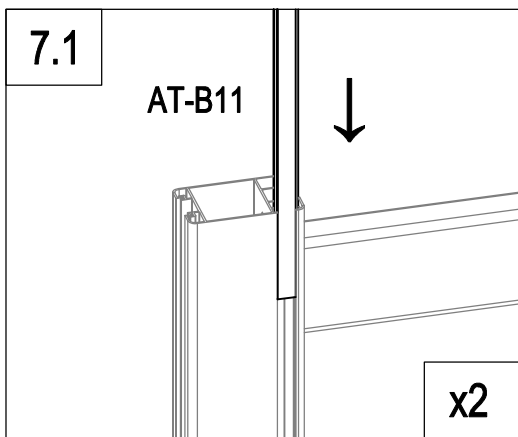
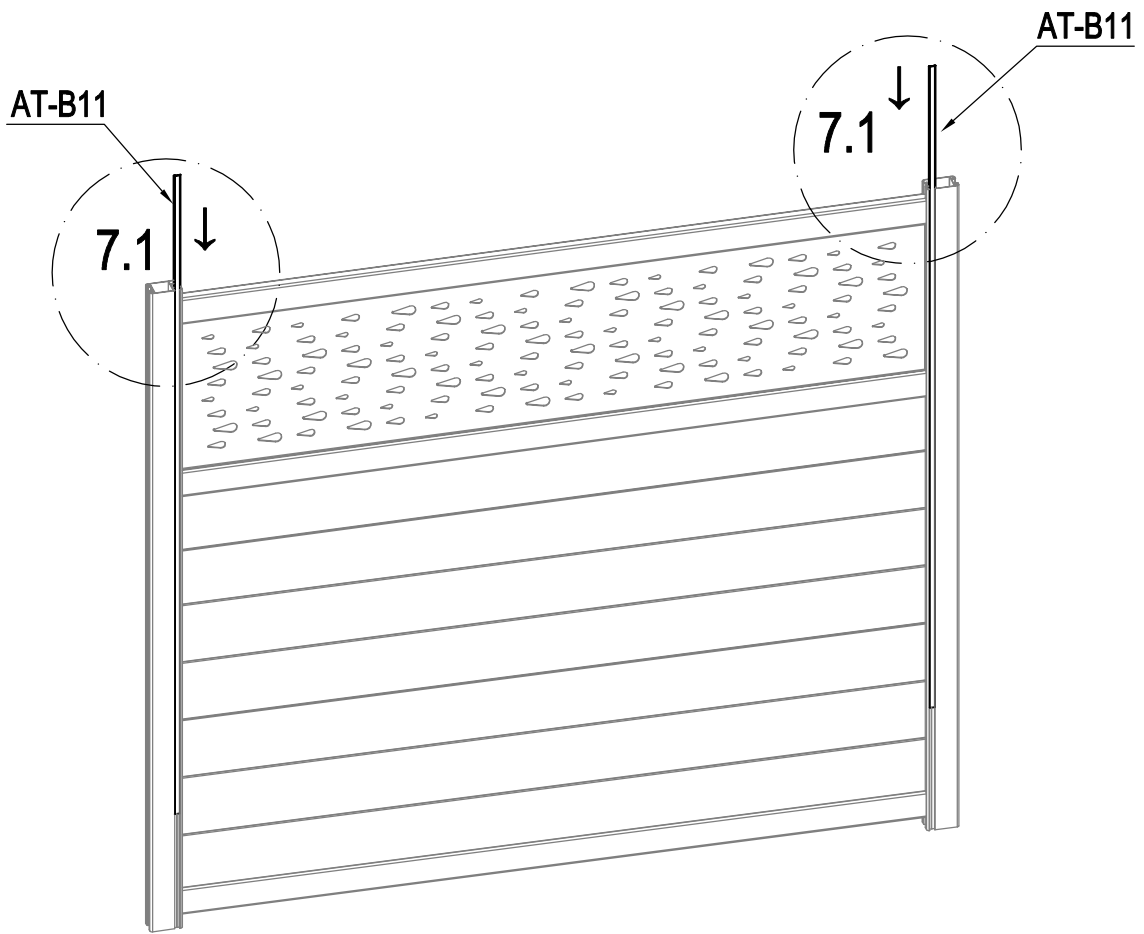

	MI-H36	34
---	--------	----



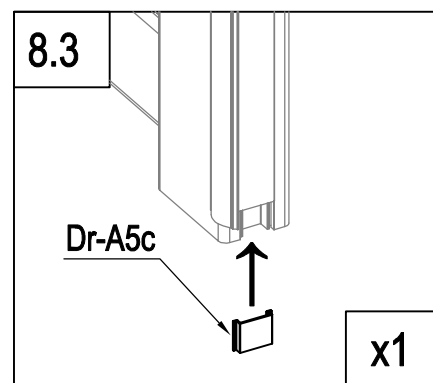
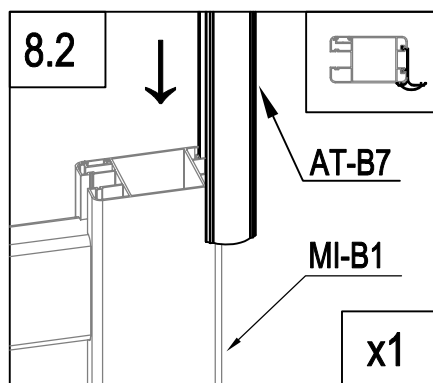
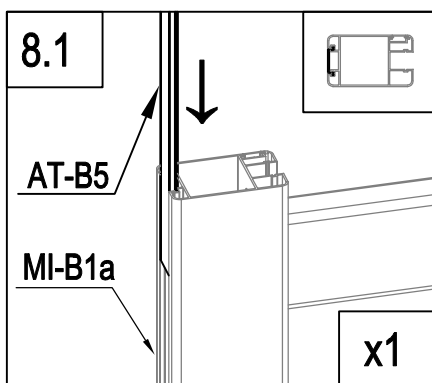
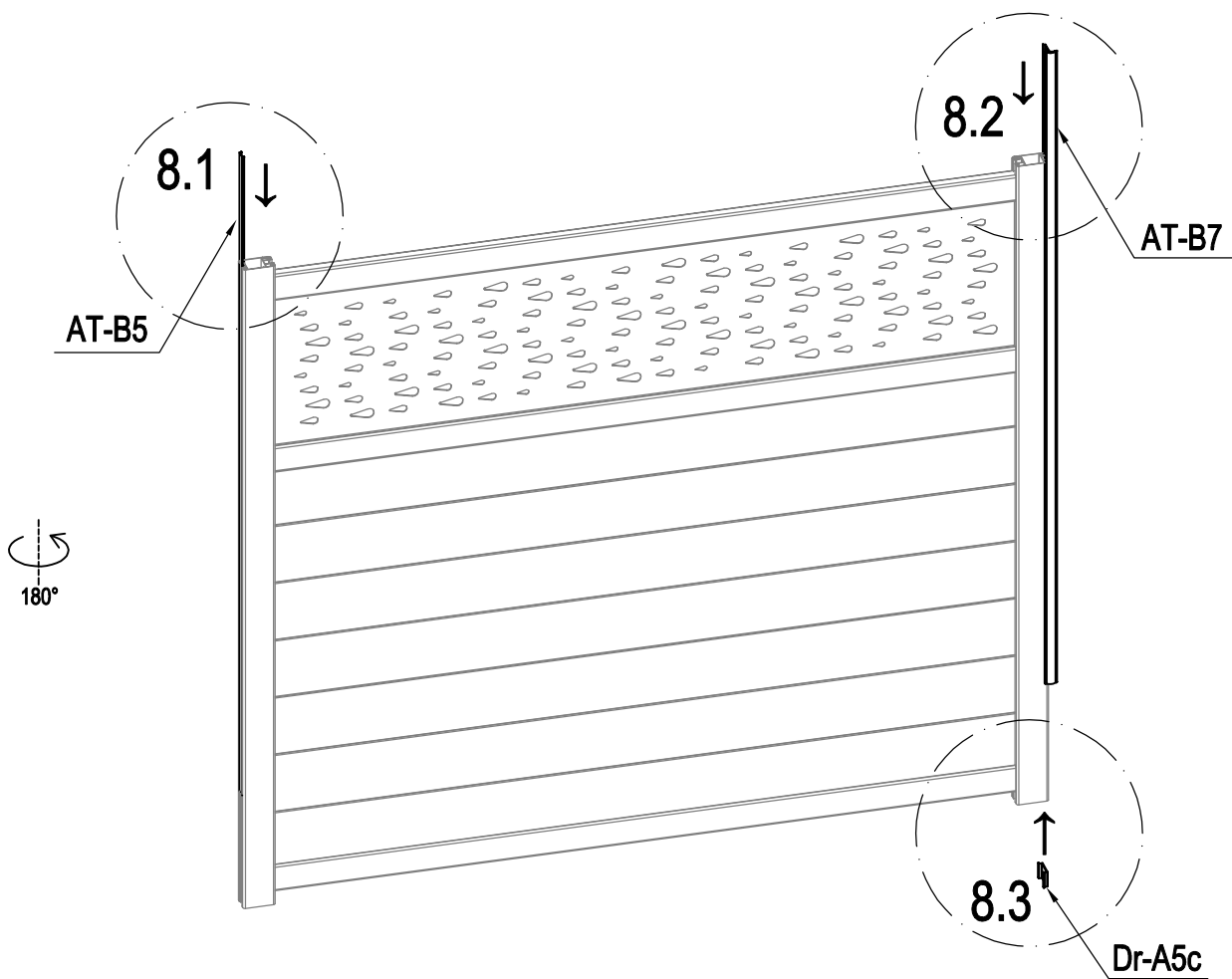



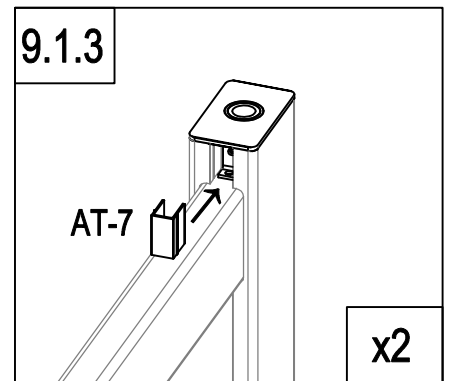
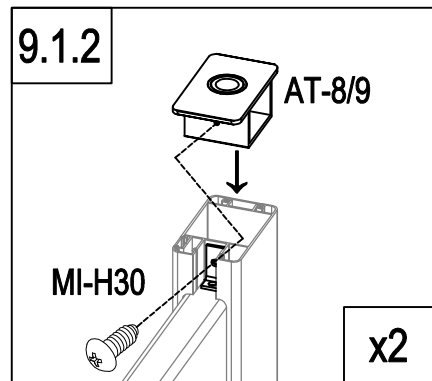
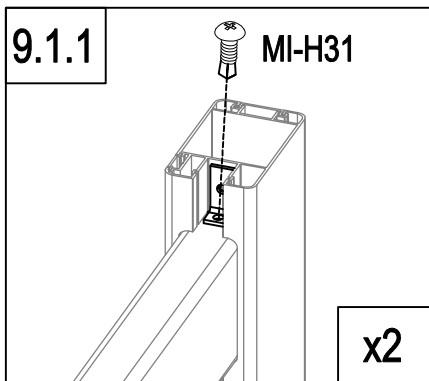
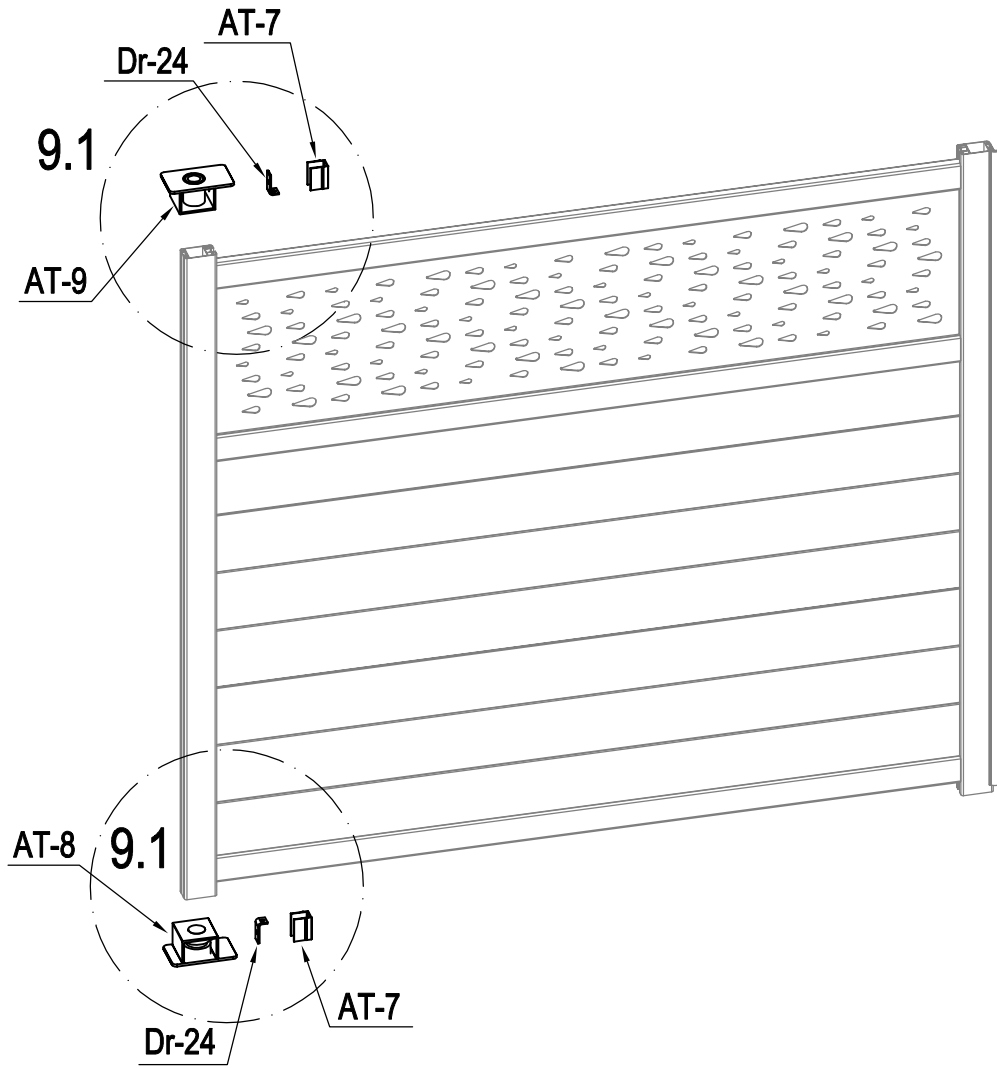

	AT-B11	2
---	--------	---



	AT-B5	1
	Dr-A5c	1
	AT-B7	1



	AT-8	1
	AT-9	1
	Dr-24	2

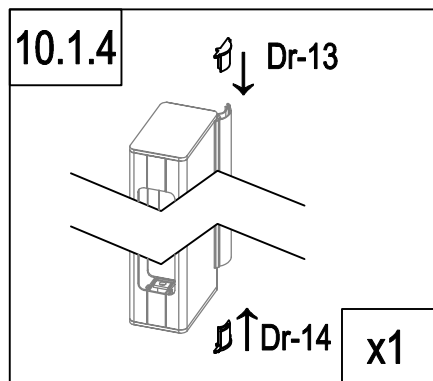
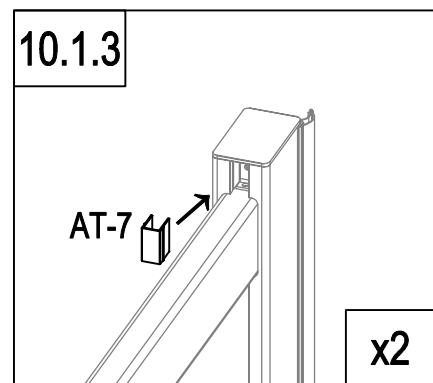
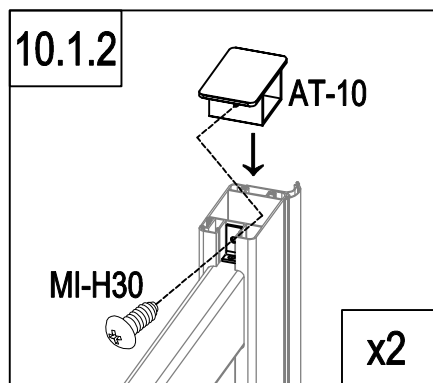
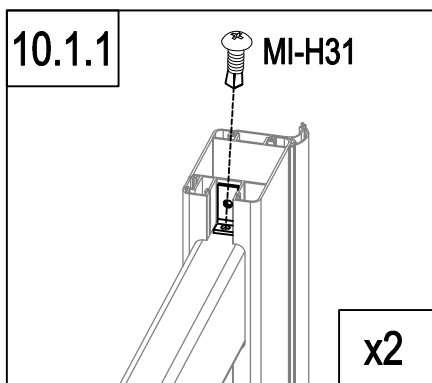
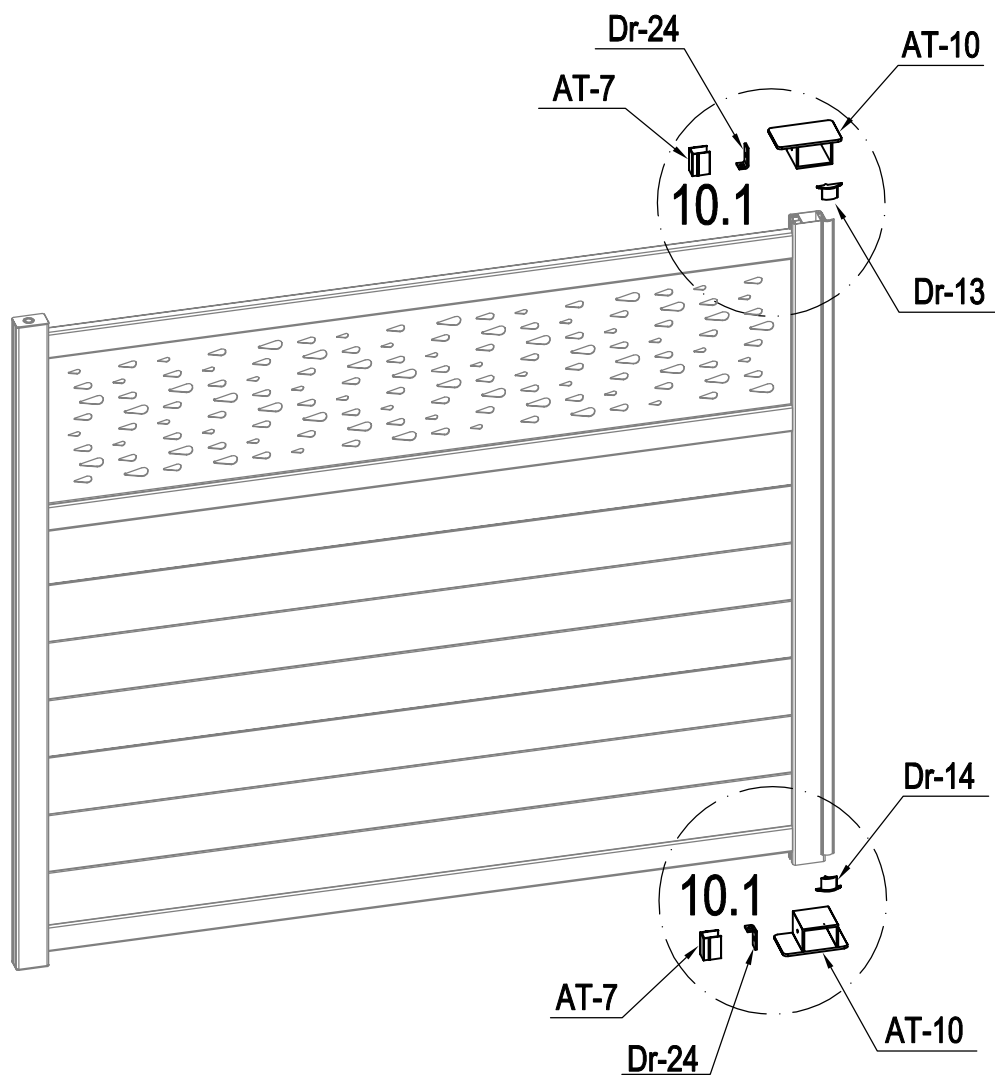

	AT-7	2
	MI-H30	2
	MI-H31	2





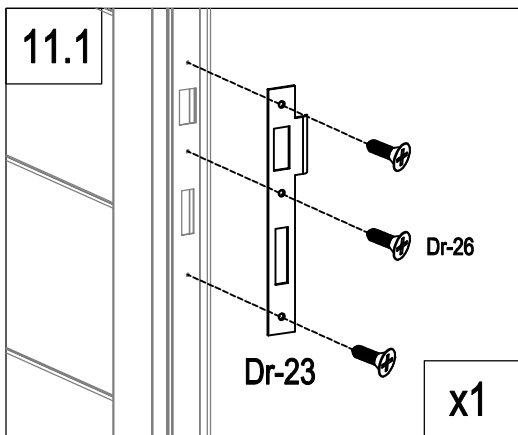
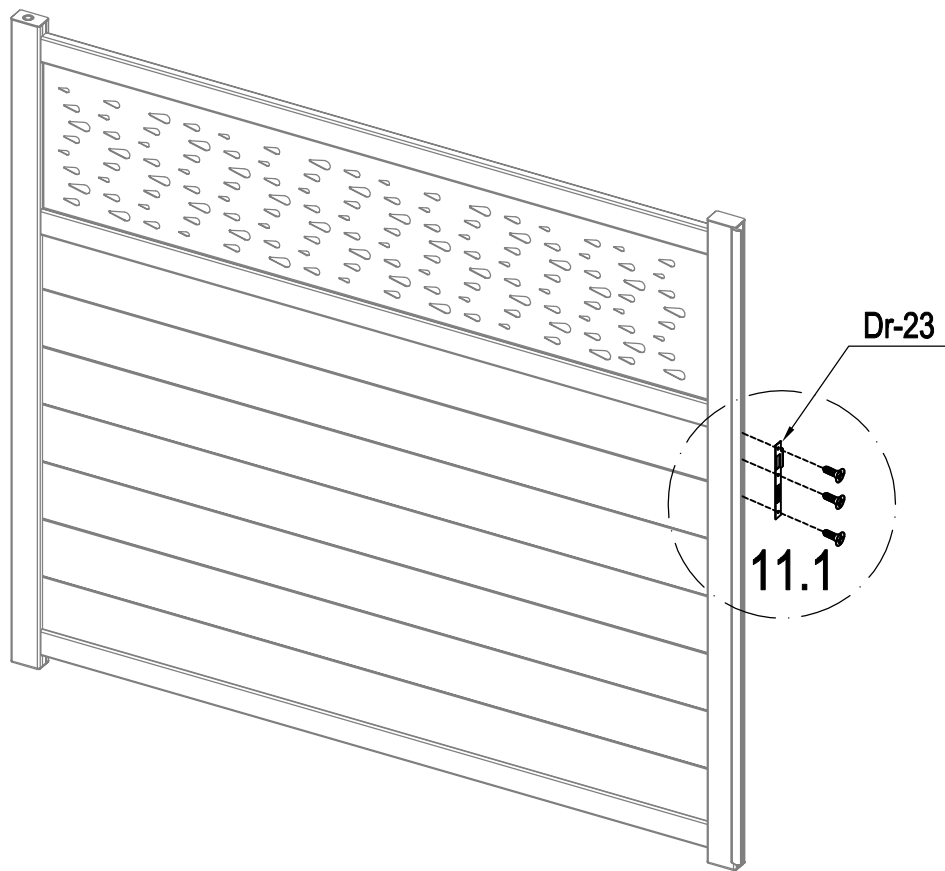

	Dr-14	1
	MI-H30	2
	MI-H31	2

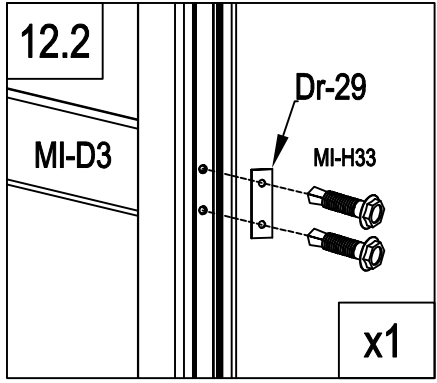
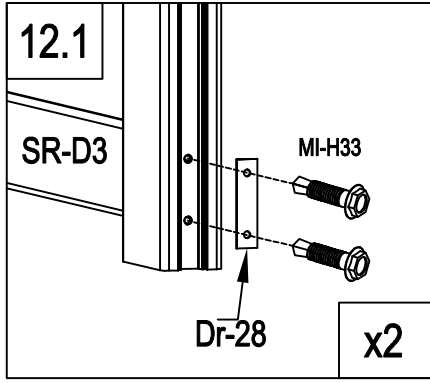
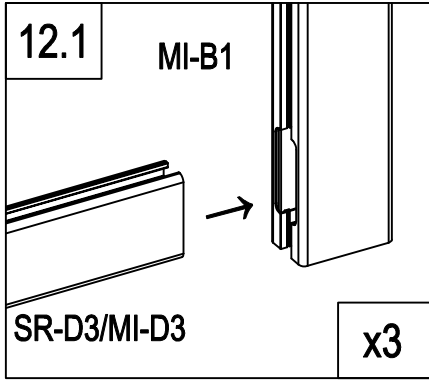
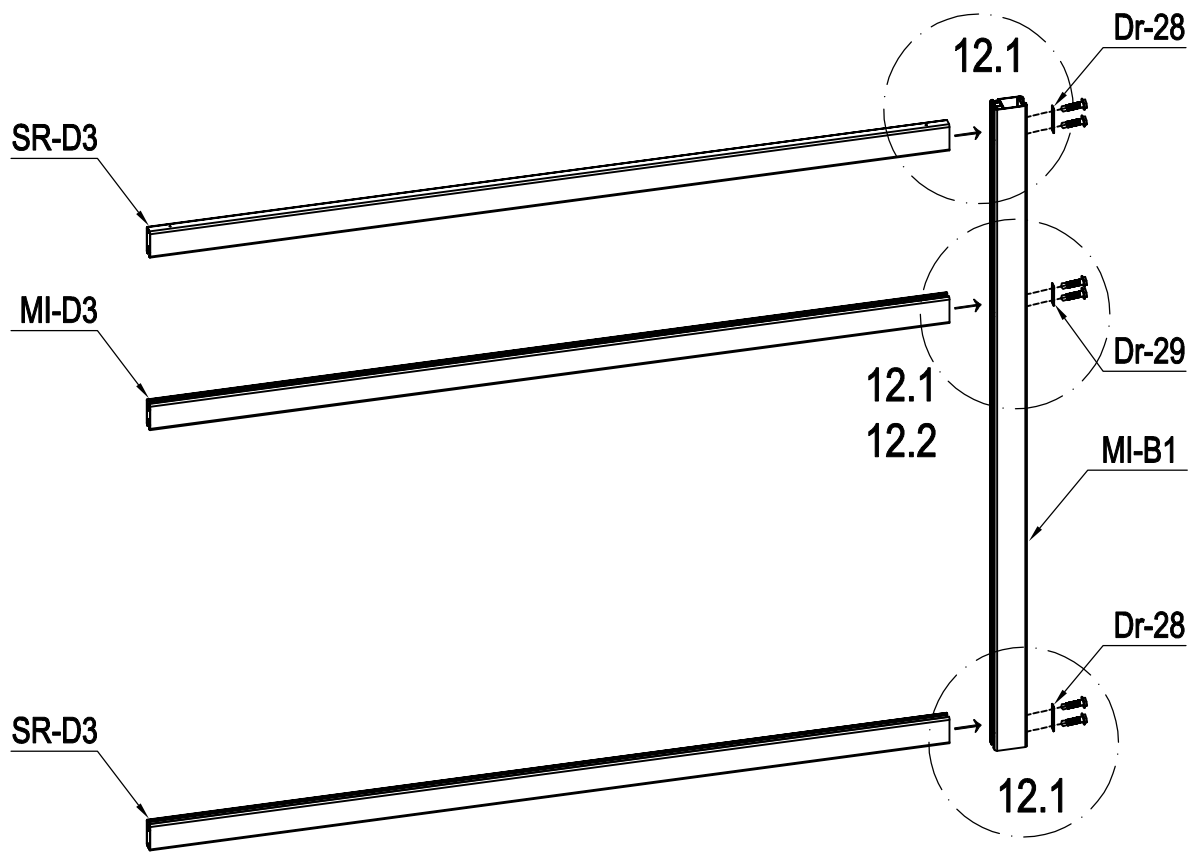

	AT-10	2
	Dr-24	2
	AT-7	2
	Dr-13	1



	Dr-23	1
	Dr-26	3



	MI-B1	1
	SR-D3	2
	MI-D3	1
	Dr-28	2

	Dr-29	1
	MI-H33	6

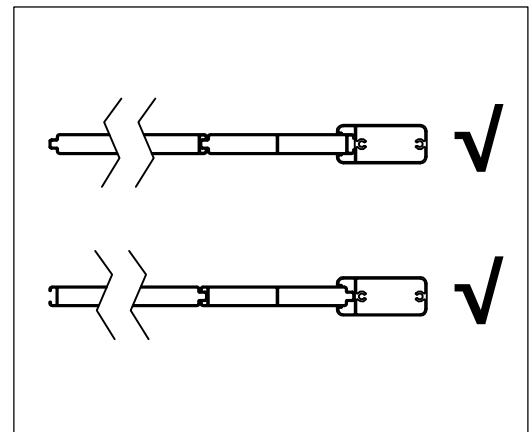
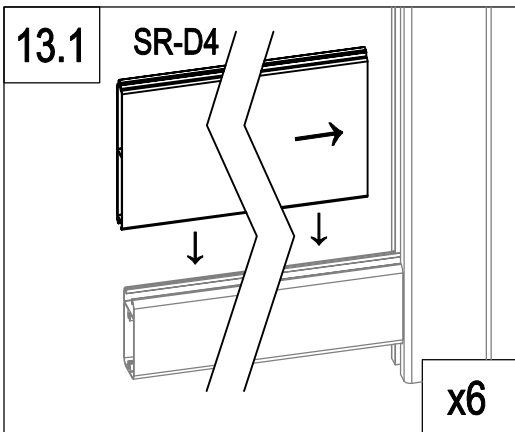
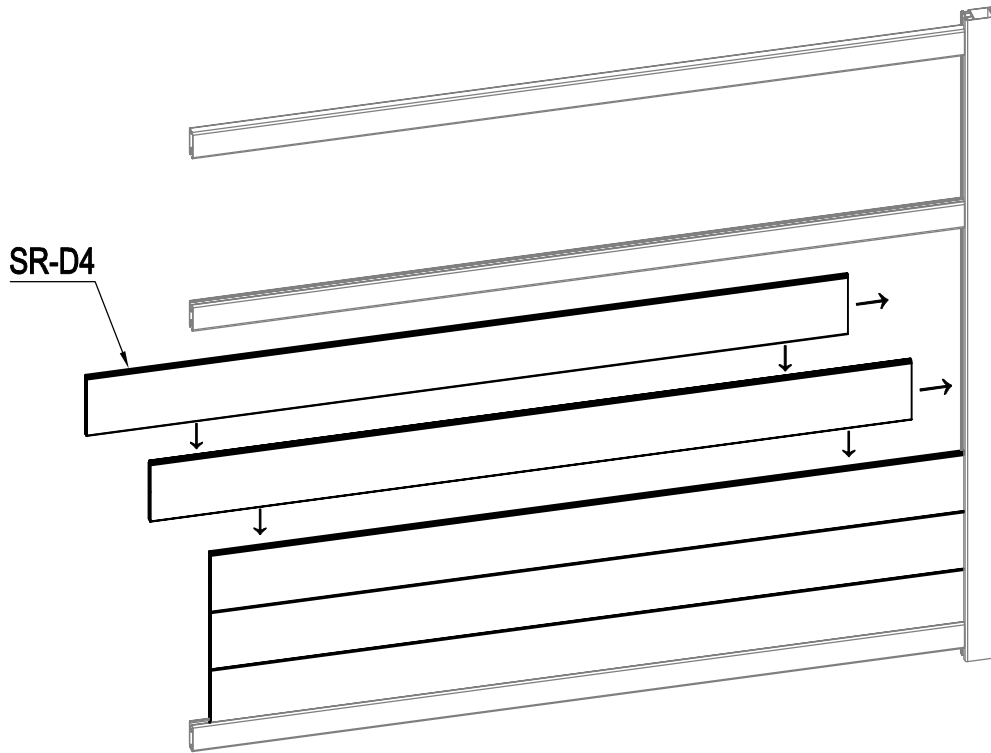



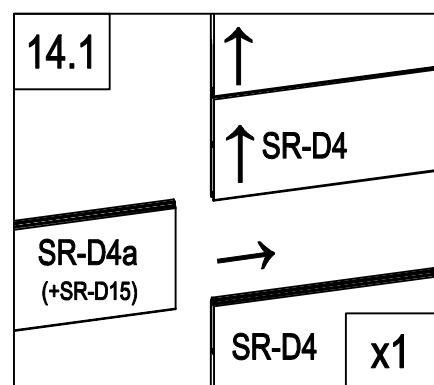
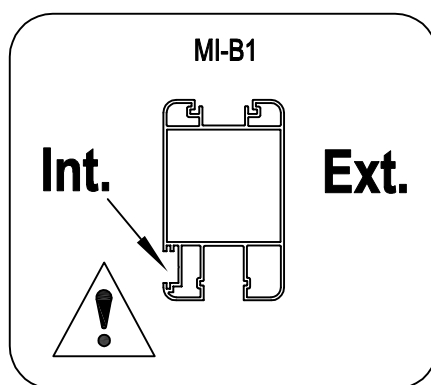
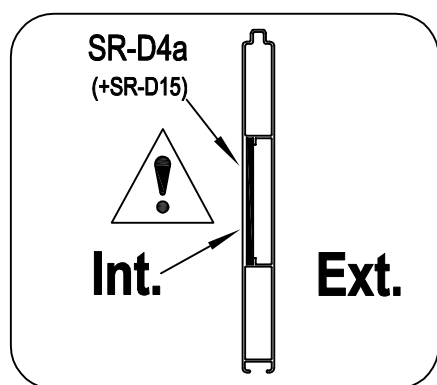
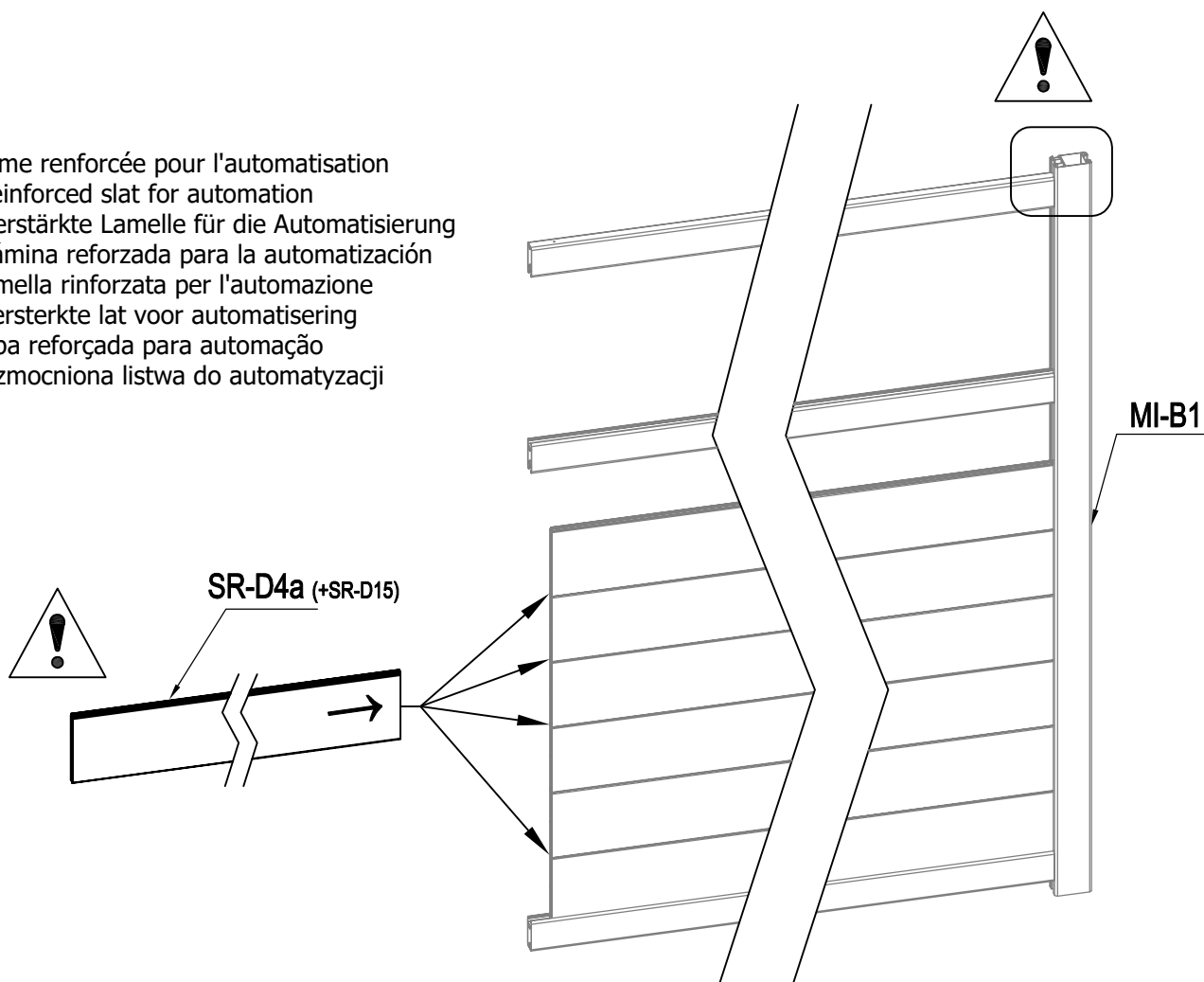

	SR-D4	6
---	-------	---

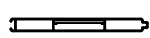
FR: lame renforcée pour l'automatisation
 EN: reinforced slat for automation
 DE: verstärkte Lamelle für die Automatisierung
 ES: Lámina reforzada para la automatización
 IT: lamella rinforzata per l'automazione
 NL: versterkte lat voor automatisering
 PT: ripa reforçada para automação
 PL: wzmocniona listwa do automatyzacji

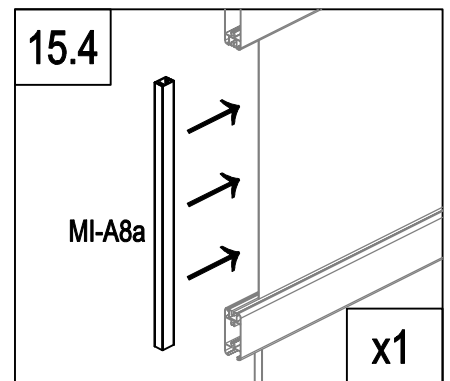
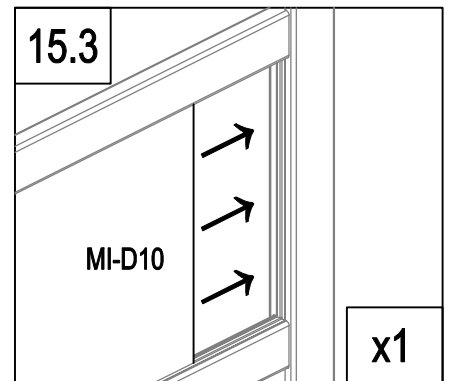
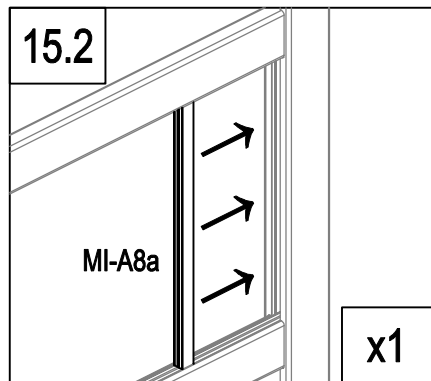
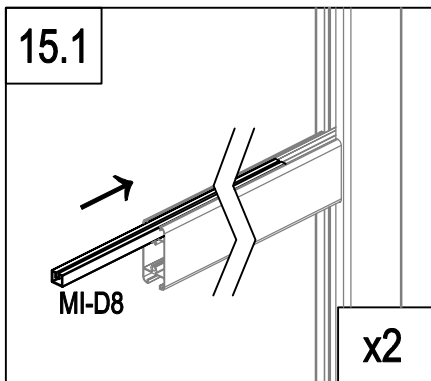
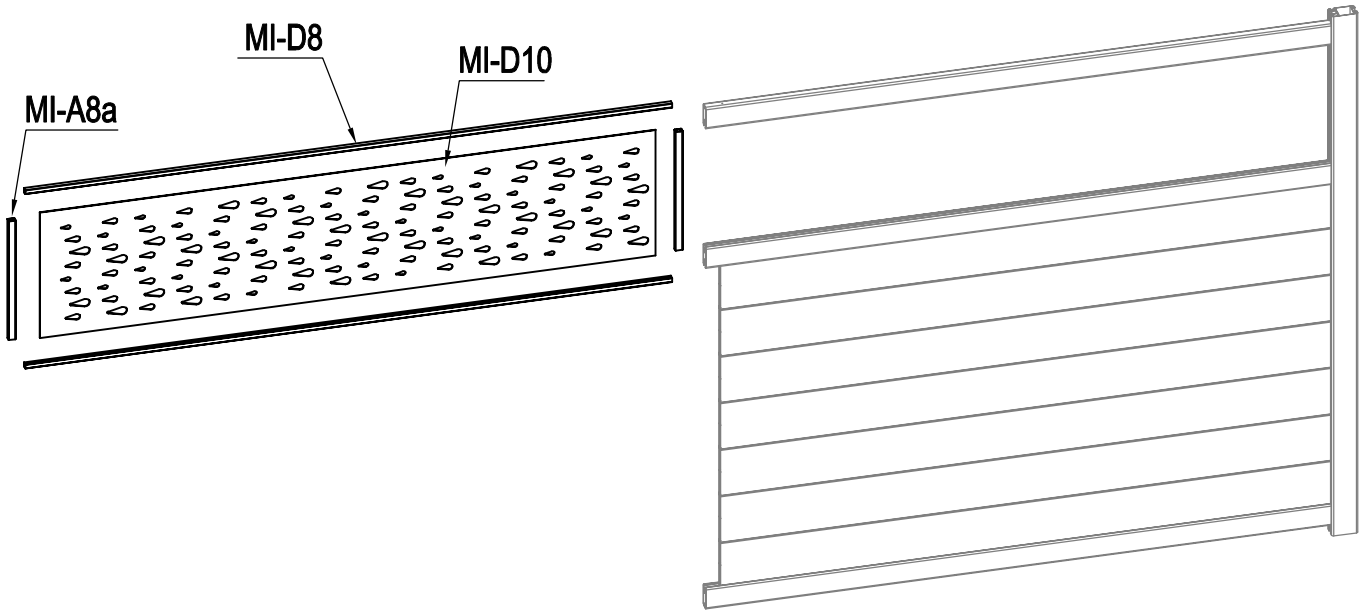





	SR-D4a (+SR-D15)	1
---	------------------	---

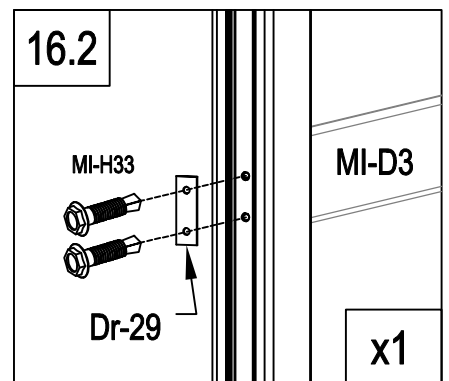
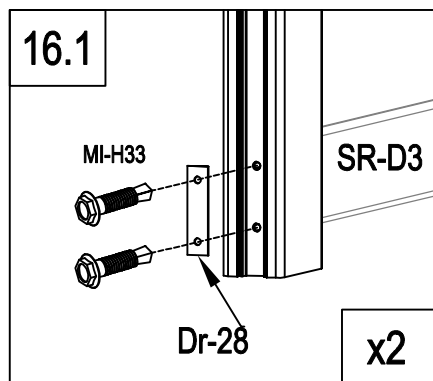
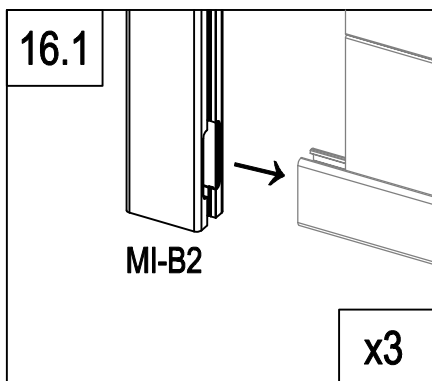
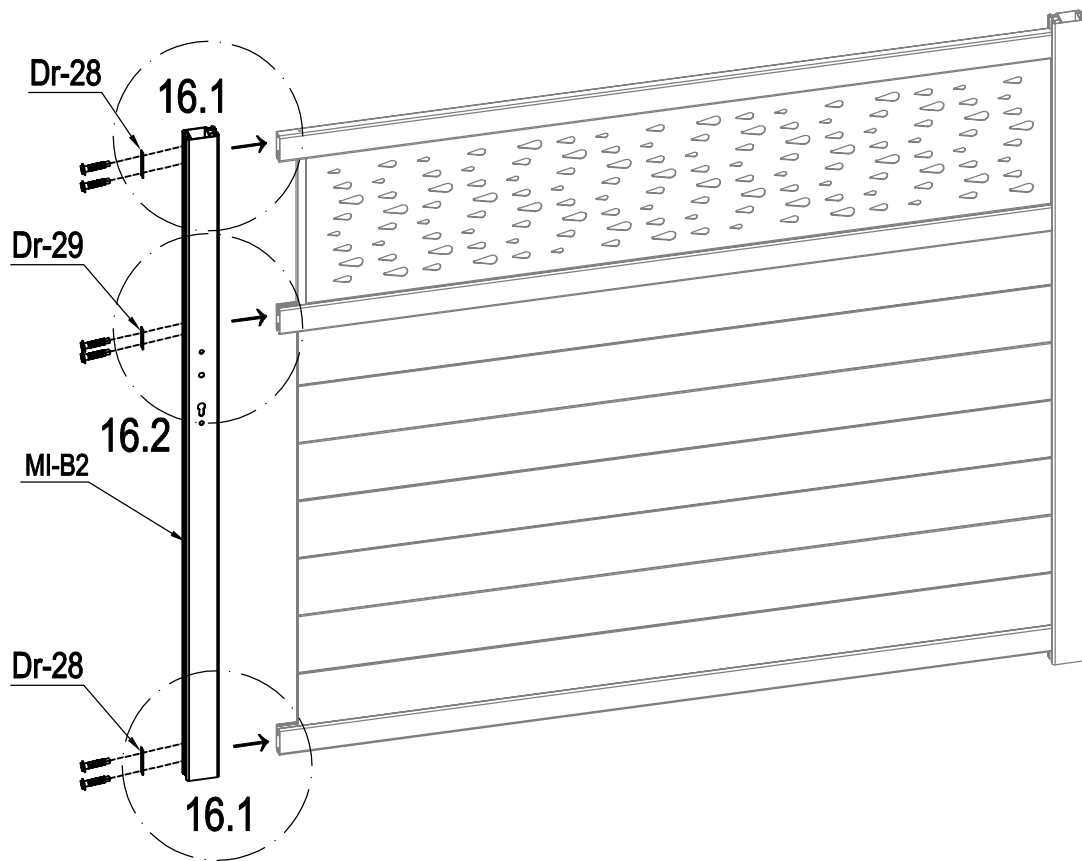

	MI-D8	2
	MI-A8a	2
	MI-D10	1



	MI-B2	1
	Dr-28	2
	Dr-29	1
	MI-H33	6

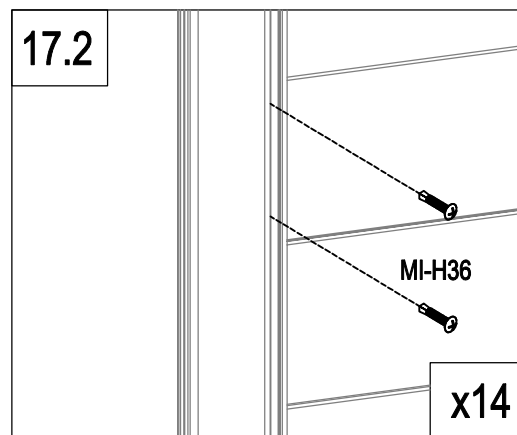
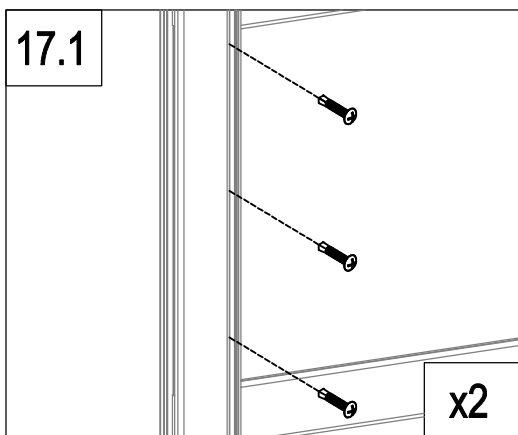
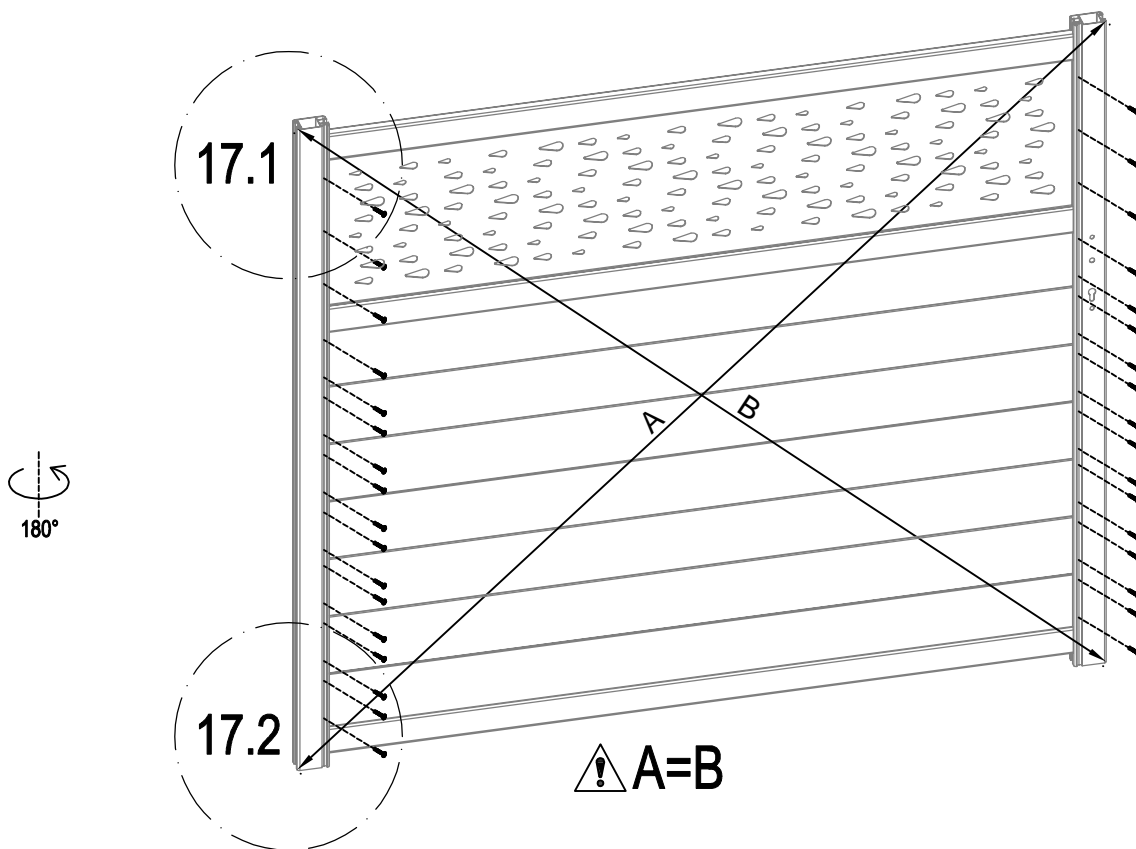

	MI-H36	34
---	--------	----

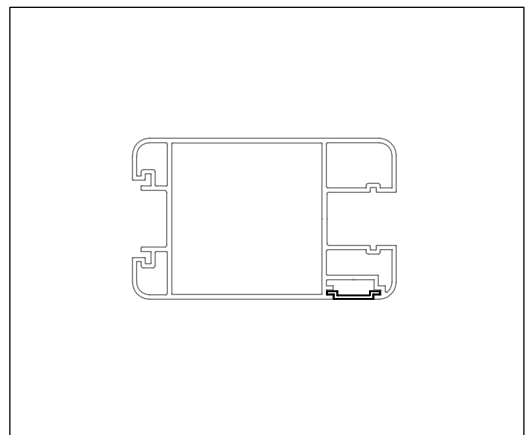
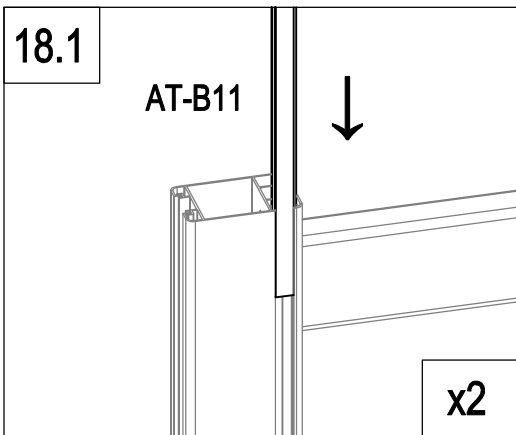
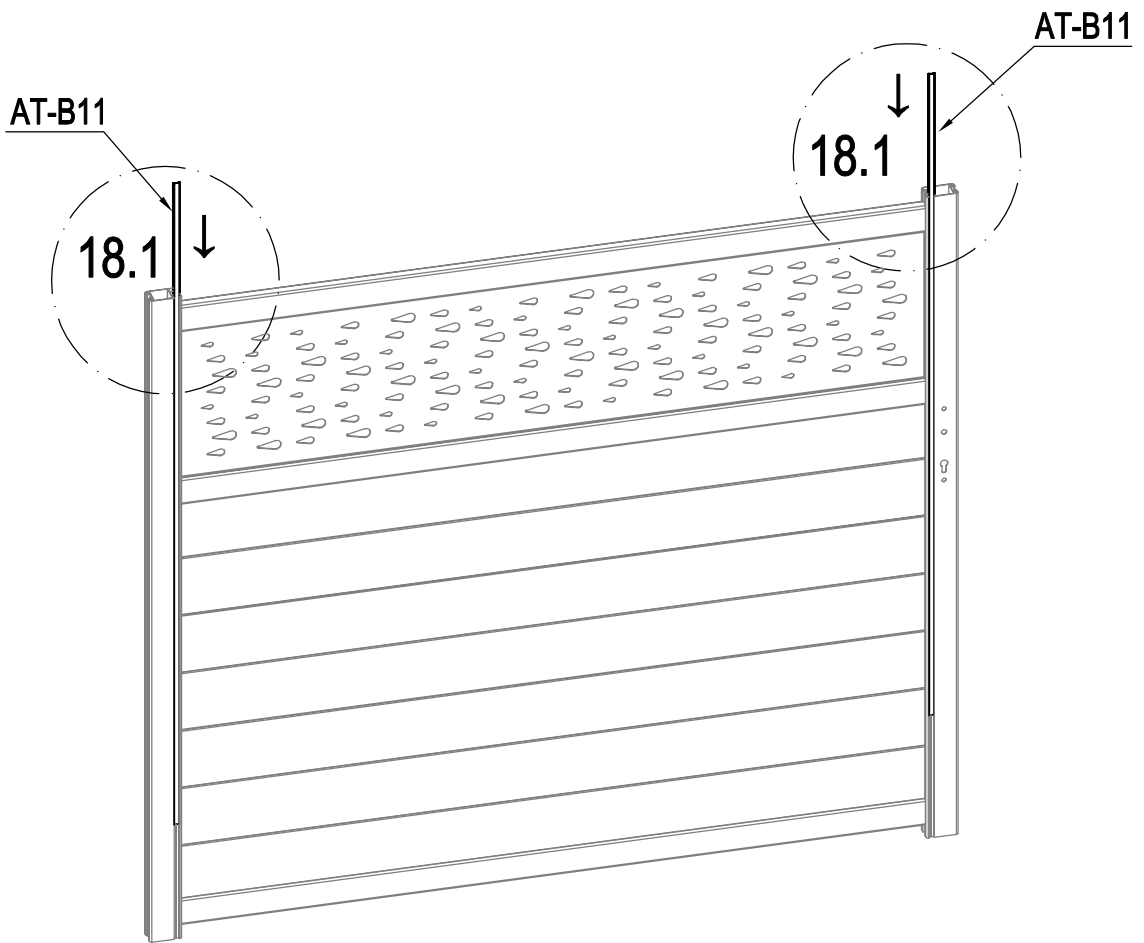

	AT-B11	2
---	---------------	----------

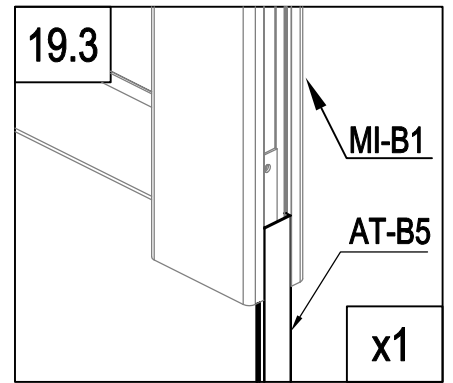
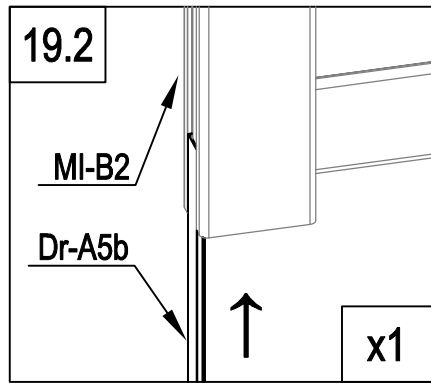
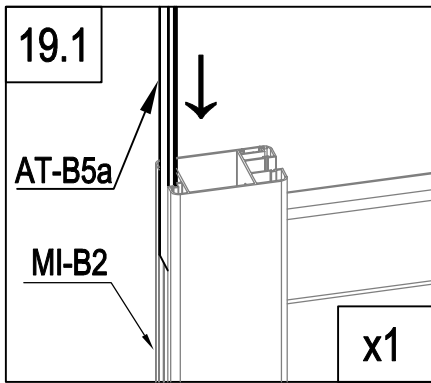
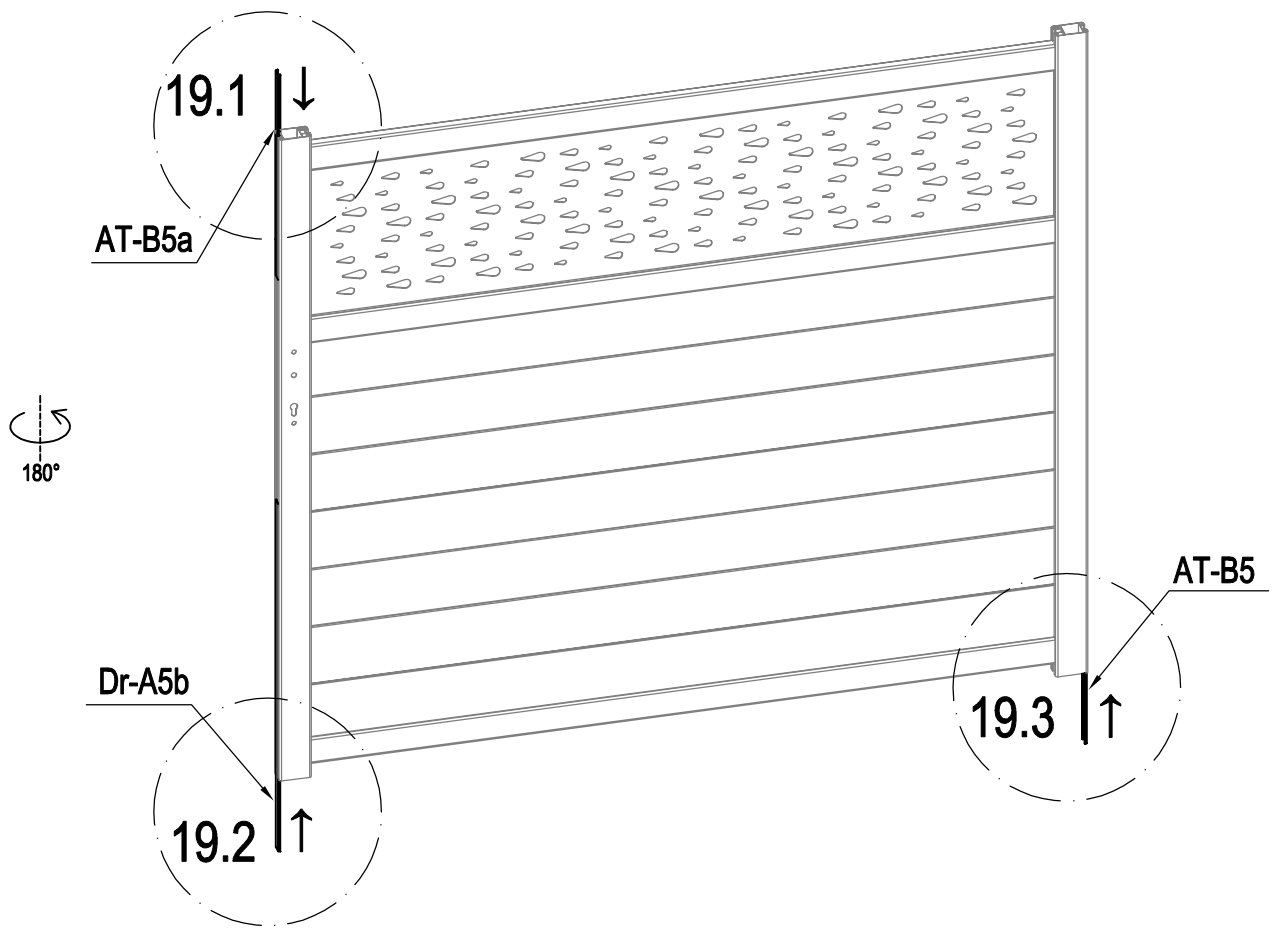

	AT-B5	1
	AT-B5a	1
	Dr-A5b	1

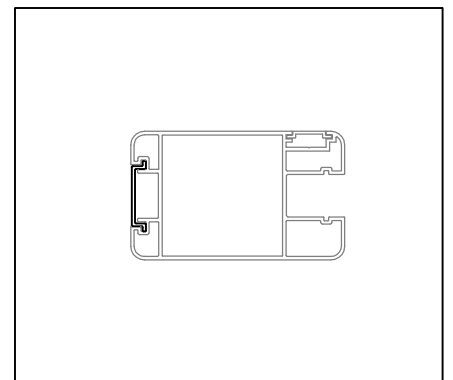

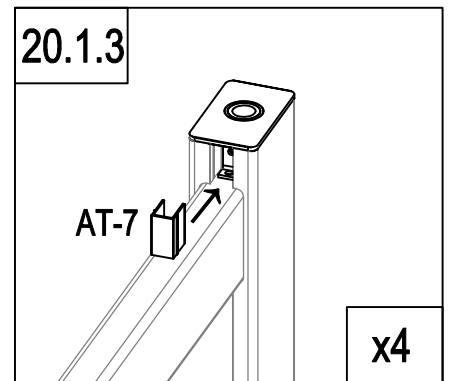
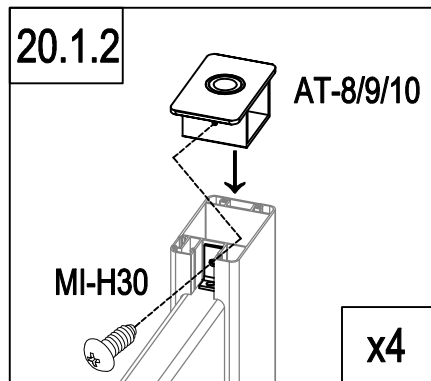
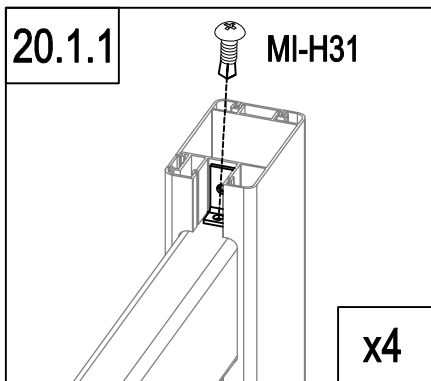
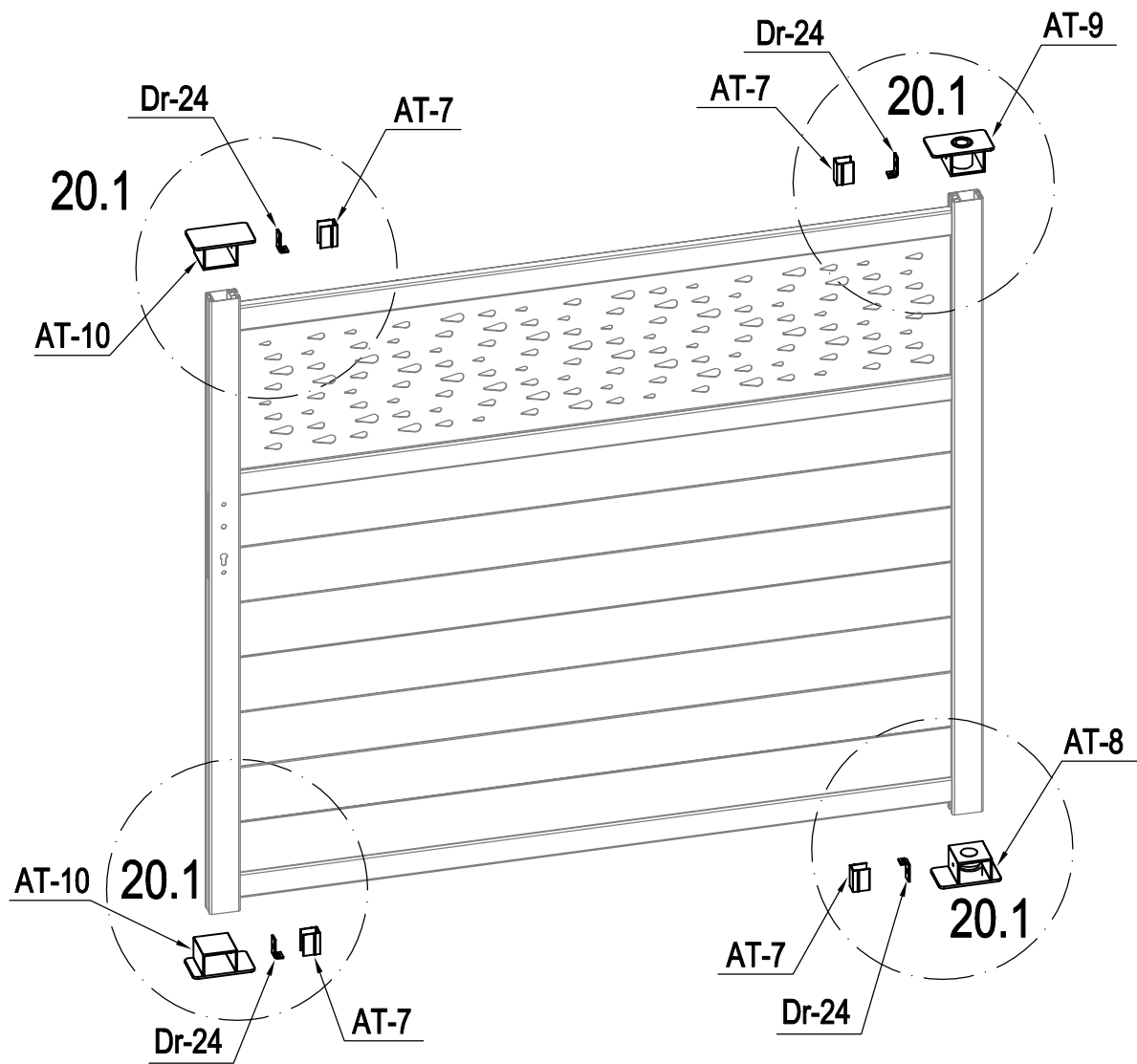

	AT-8	1
	AT-9	1
	AT-10	2
	Dr-24	4

	AT-7	4
	MI-H30	4
	MI-H31	4

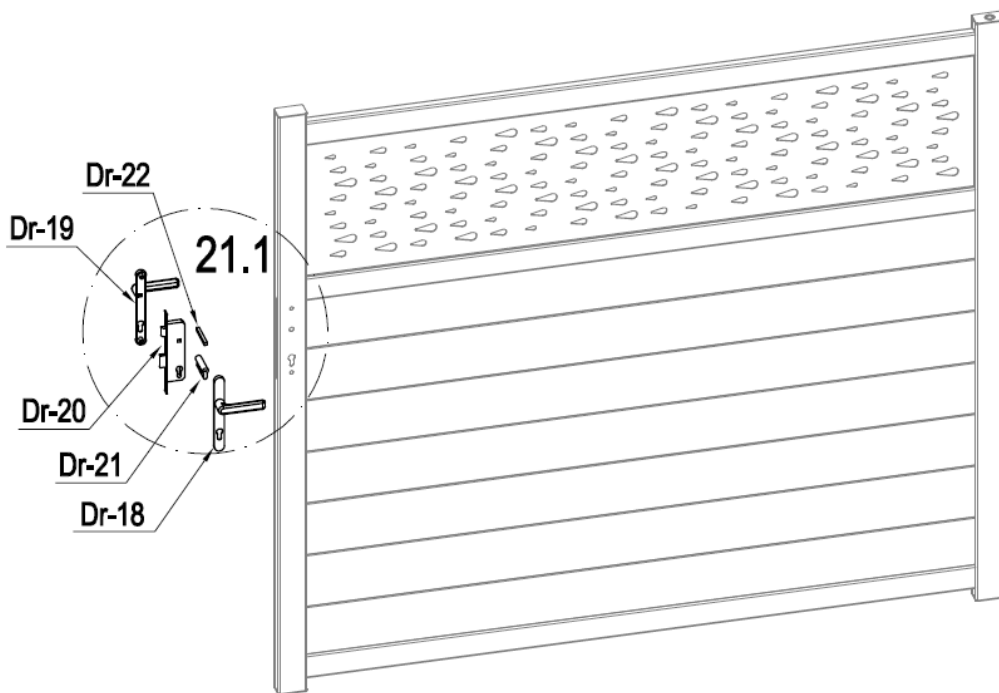

	Dr-20	1
	Dr-21	1

FR: Si vous n'installez pas l'ouvre-porte automatique, reportez-vous simplement aux étapes d'instructions suivantes. Si vous devez installer l'ouvre-porte automatique, n'installez pas les accessoires Dr-20 (corps de serrure) et Dr-21 (cylindre de serrure).

EN: if not to install the Automatic Gate Opener, just refer to following instruction steps. If need to install the Automatic Gate Opener, do not install accessory Dr-20(lock body) and Dr-21(lock cylinder).

DE: Wenn Sie den automatischen Toröffner nicht installieren möchten, befolgen Sie einfach die folgenden Anweisungen. Wenn der automatische Toröffner installiert werden muss, installieren Sie nicht die Zubehörteile Dr-20 (Schlosskörper) und Dr-21 (Schließzylinder).

ES: si no va a instalar el abrepuertas automático, simplemente consulte los siguientes pasos de instrucciones. Si necesita instalar el abrepuertas automático, no instale el accesorio Dr-20 (cuerpo de la cerradura) y Dr-21 (cilindro de la cerradura).

IT: se non per installare l'apricancello automatico, fare riferimento ai seguenti passaggi delle istruzioni. Se è necessario installare l'apricancello automatico, non installare l'accessorio Dr-20 (corpo serratura) e Dr-21 (cilindro serratura).

NL: als u de automatische poortopener niet wilt installeren, raadpleeg dan de volgende instructies. Als u de automatische poortopener moet installeren, installeer dan geen accessoire Dr-20 (slotlichaam) en Dr-21 (slotcilinder).

PT: se não for instalar o Abridor de Portão Automático, basta consultar as seguintes etapas de instruções. Caso seja necessário instalar o Abridor Automático, não instale o acessório Dr-20(corpo da fechadura) e Dr-21(cilindro da fechadura).

PL: jeśli nie chcesz zainstalować automatu do otwierania bram, zapoznaj się z poniższymi krokami instrukcji. Jeśli zachodzi potrzeba zainstalowania automatycznego urządzenia do otwierania bram, nie należy instalować akcesoriów Dr-20 (korpus zamka) i Dr-21 (cylinder zamka).

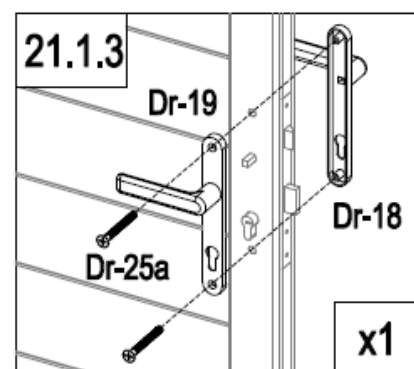
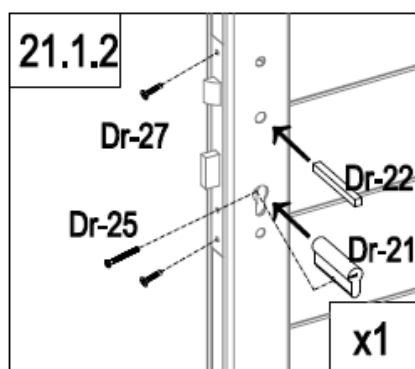
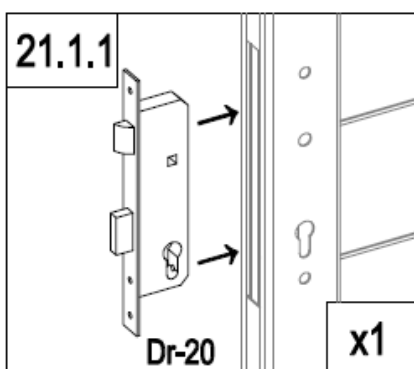

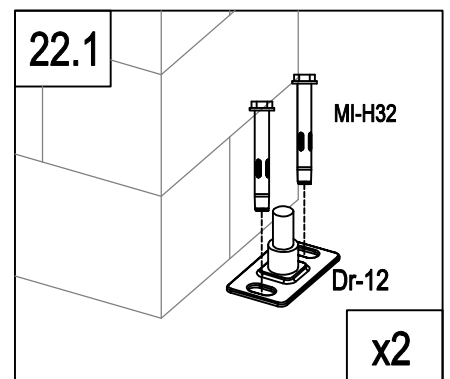
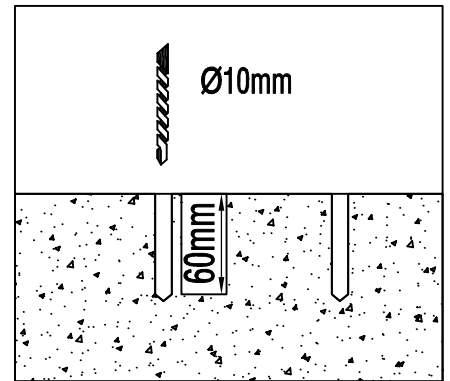
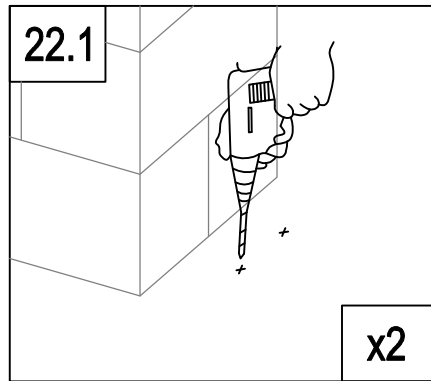
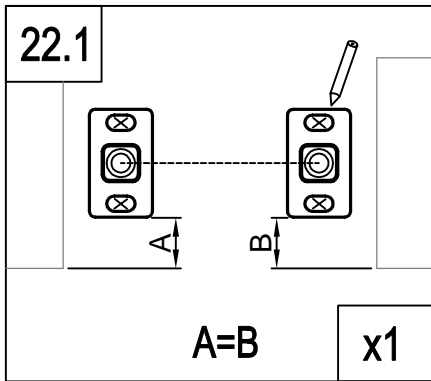
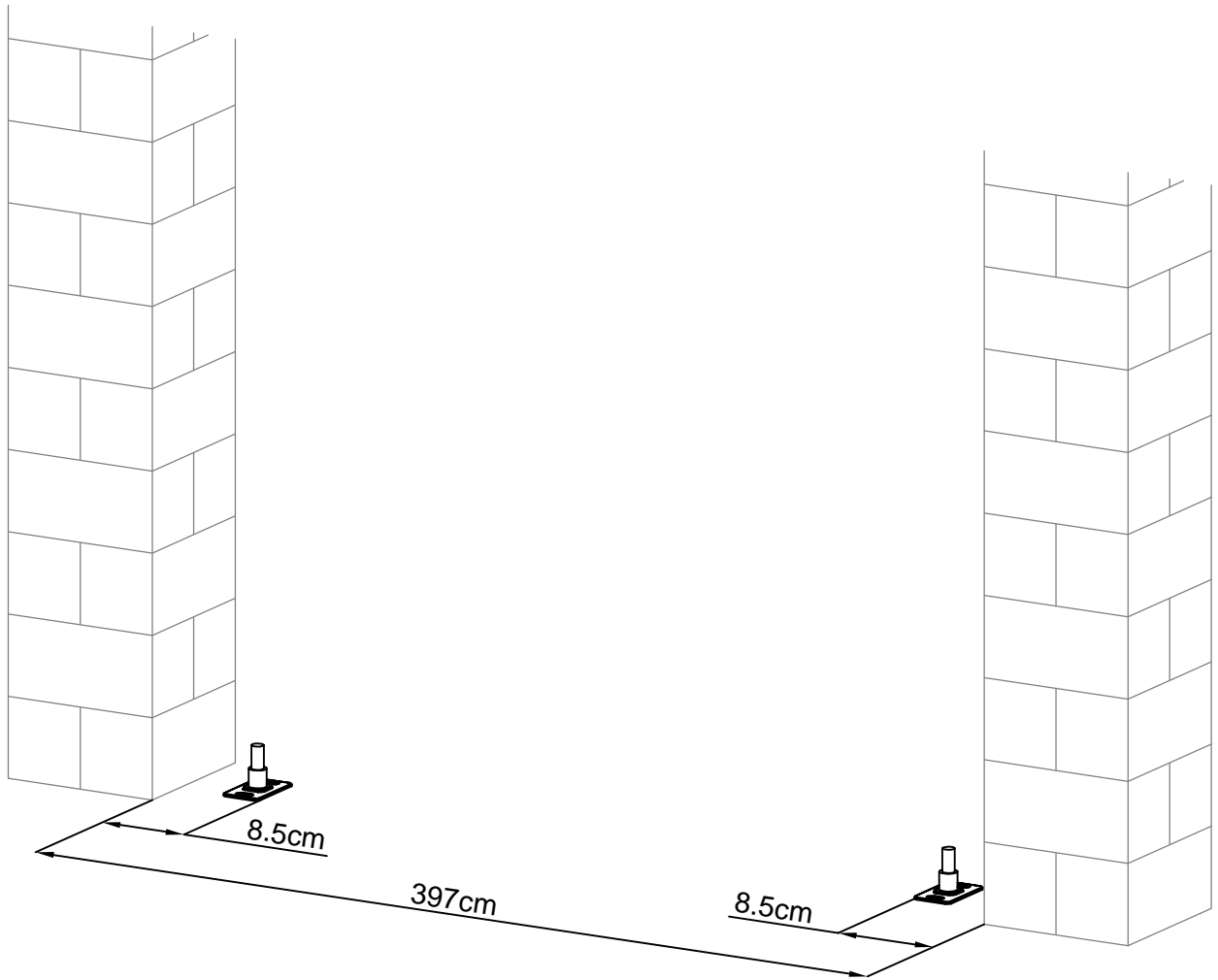

	Dr-20	1
	Dr-21	1
	Dr-22	1
	Dr-25	1

	Dr-18	1
	Dr-19	1
	Dr-25a	2
	Dr-27	2



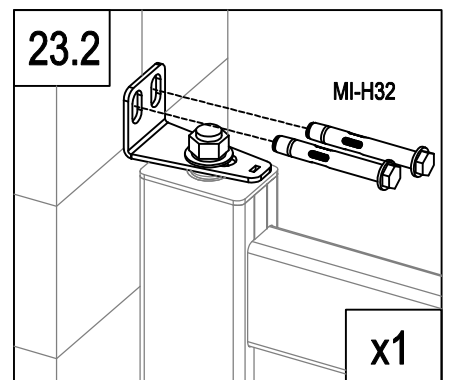
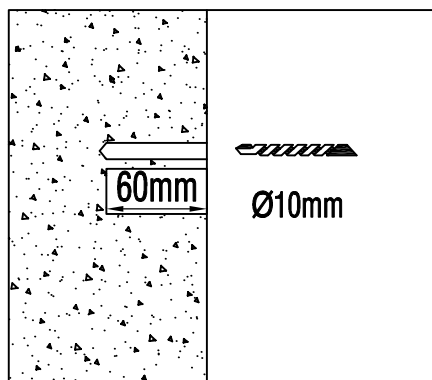
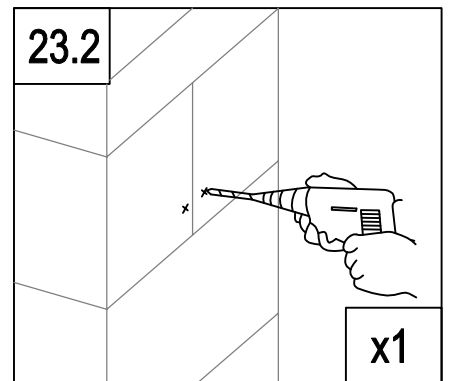
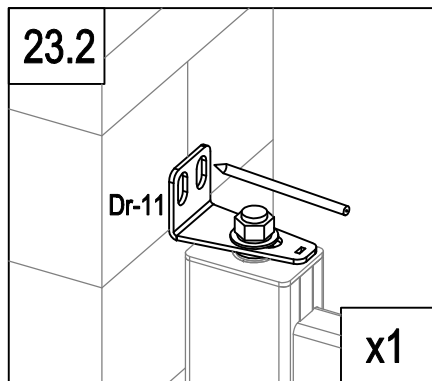
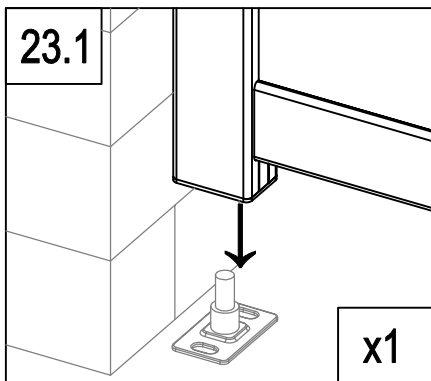
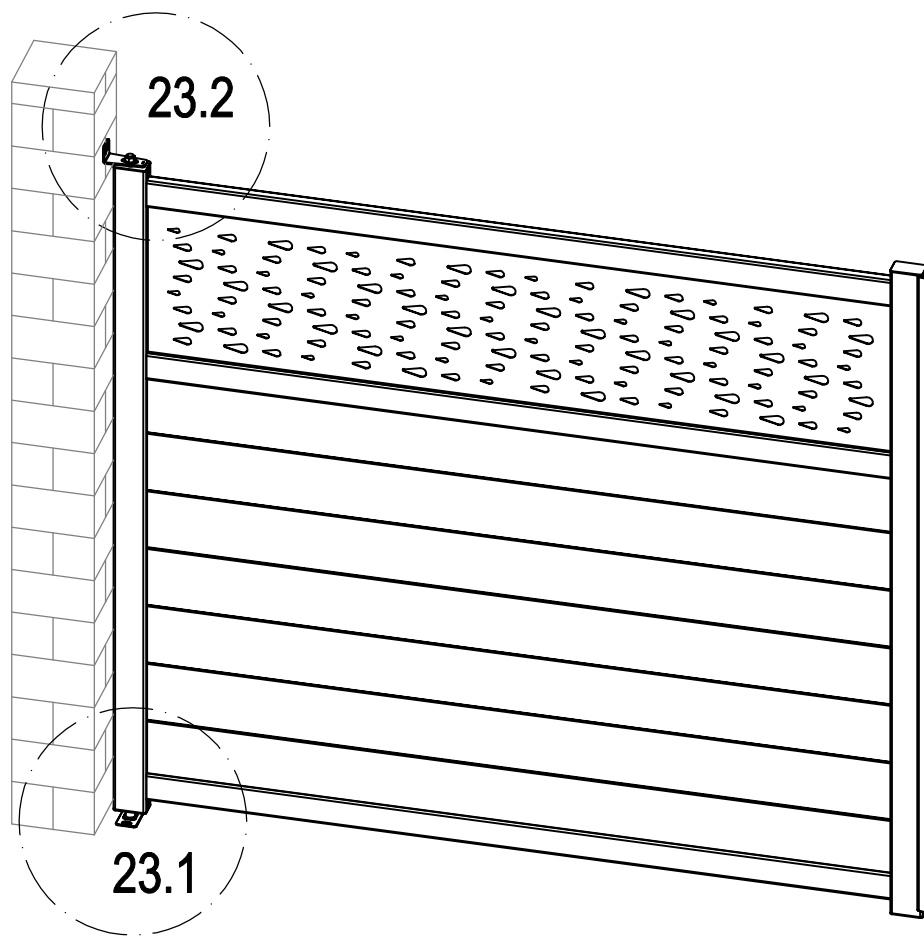

	Dr-12	2
	MI-H32	4



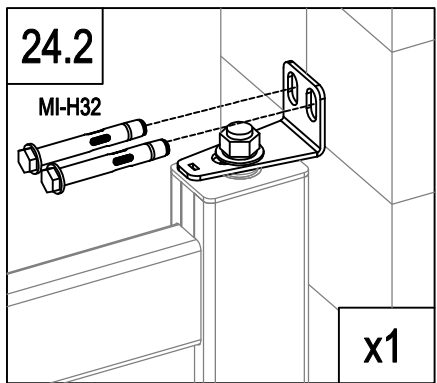
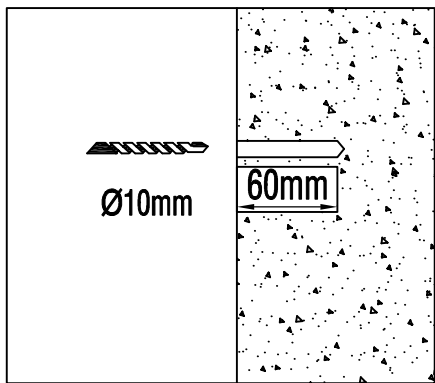
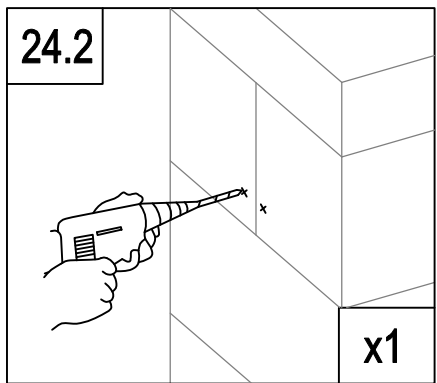
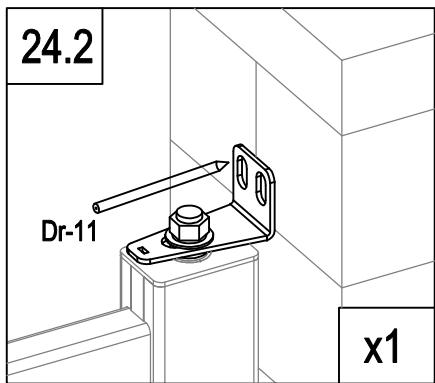
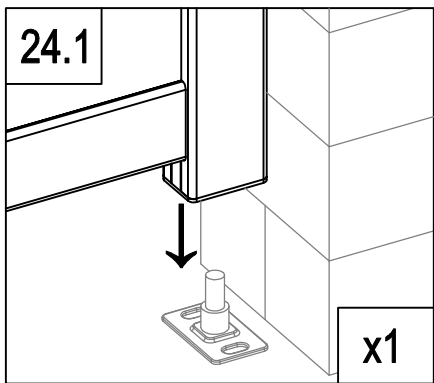
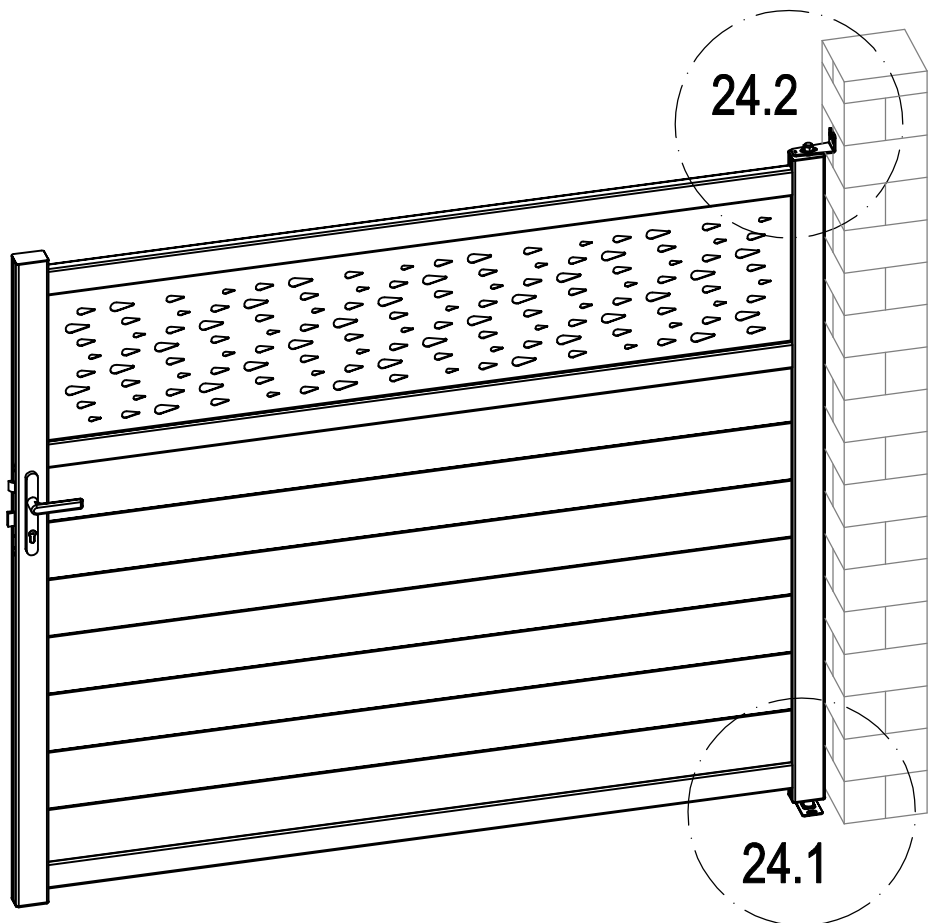

	Dr-11	1
	MI-H32	2

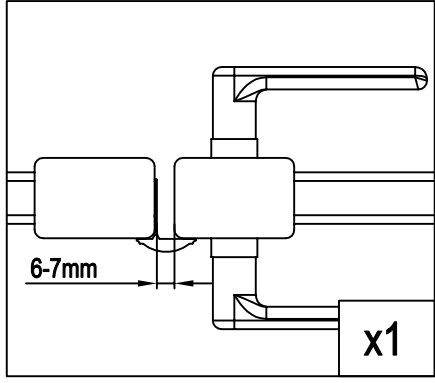
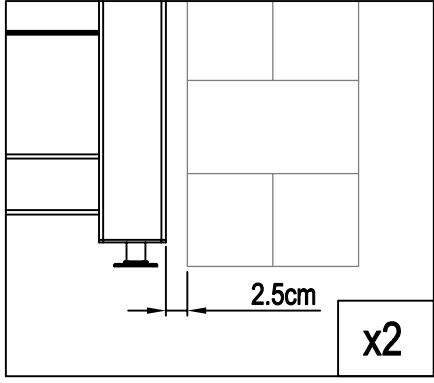
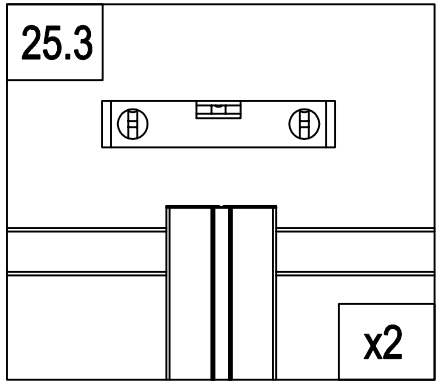
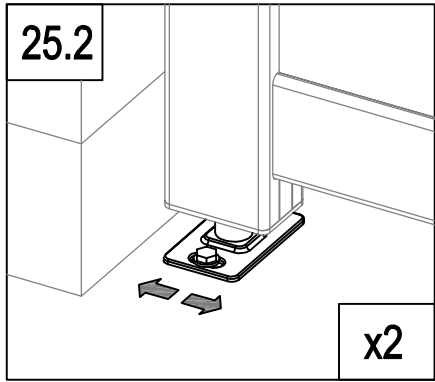
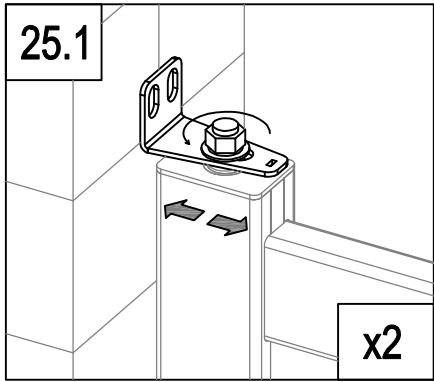
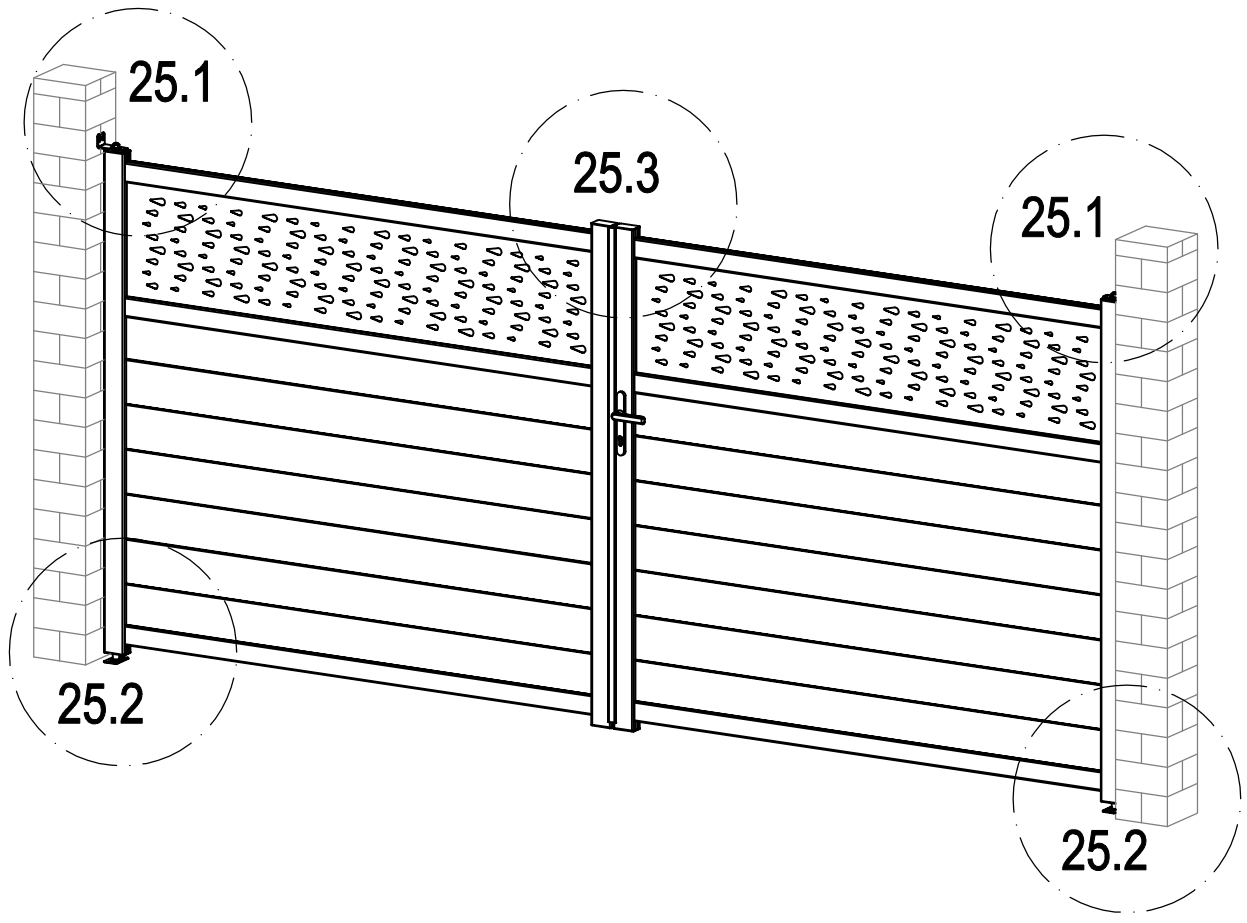

	Dr-11	1
	MI-H32	2

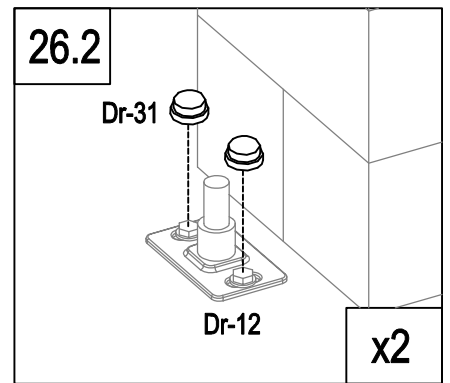
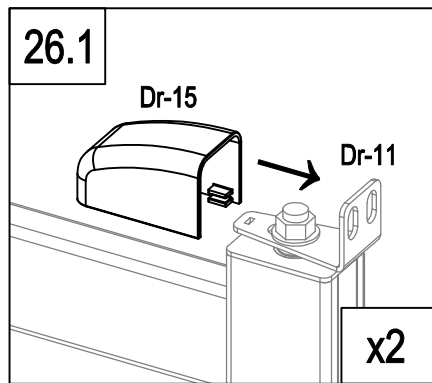
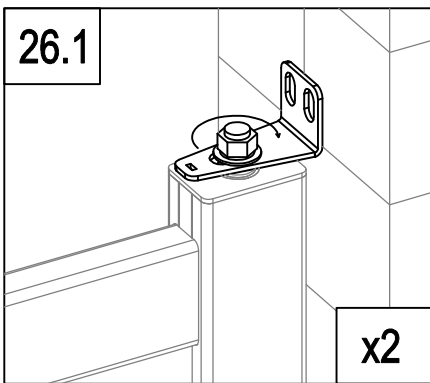
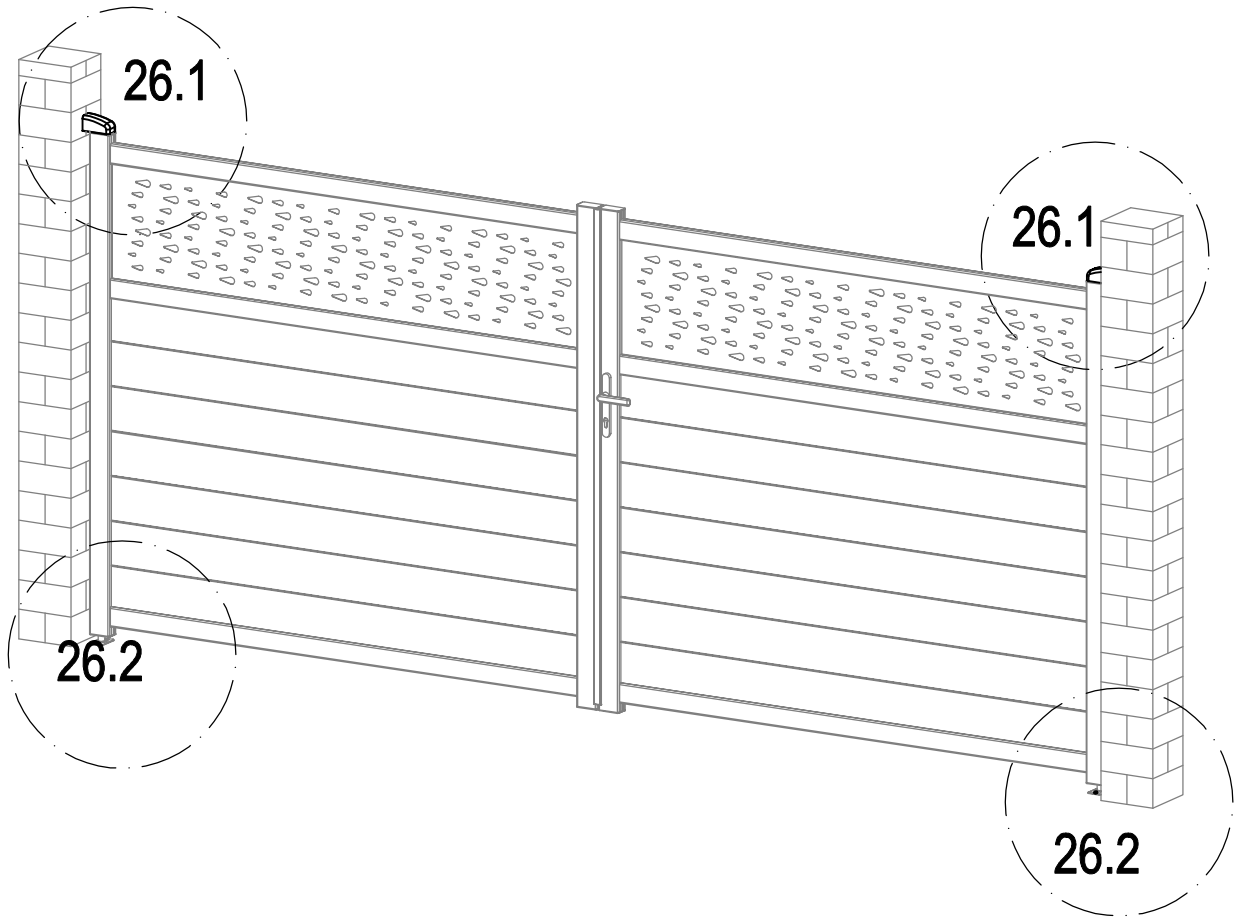



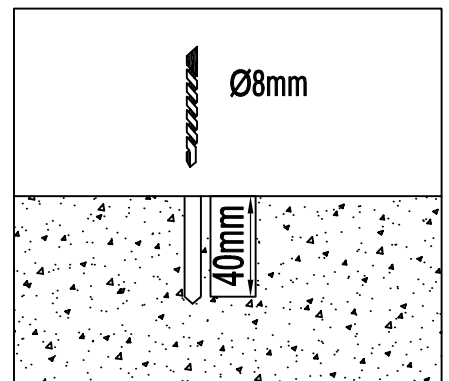
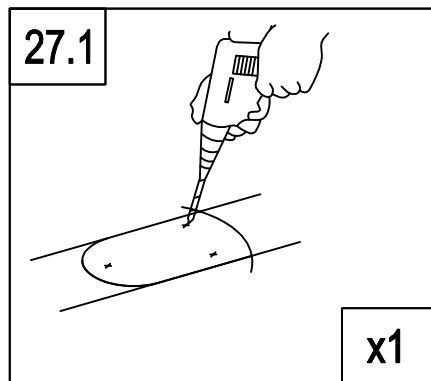
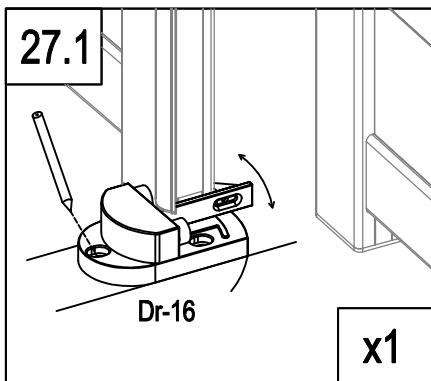
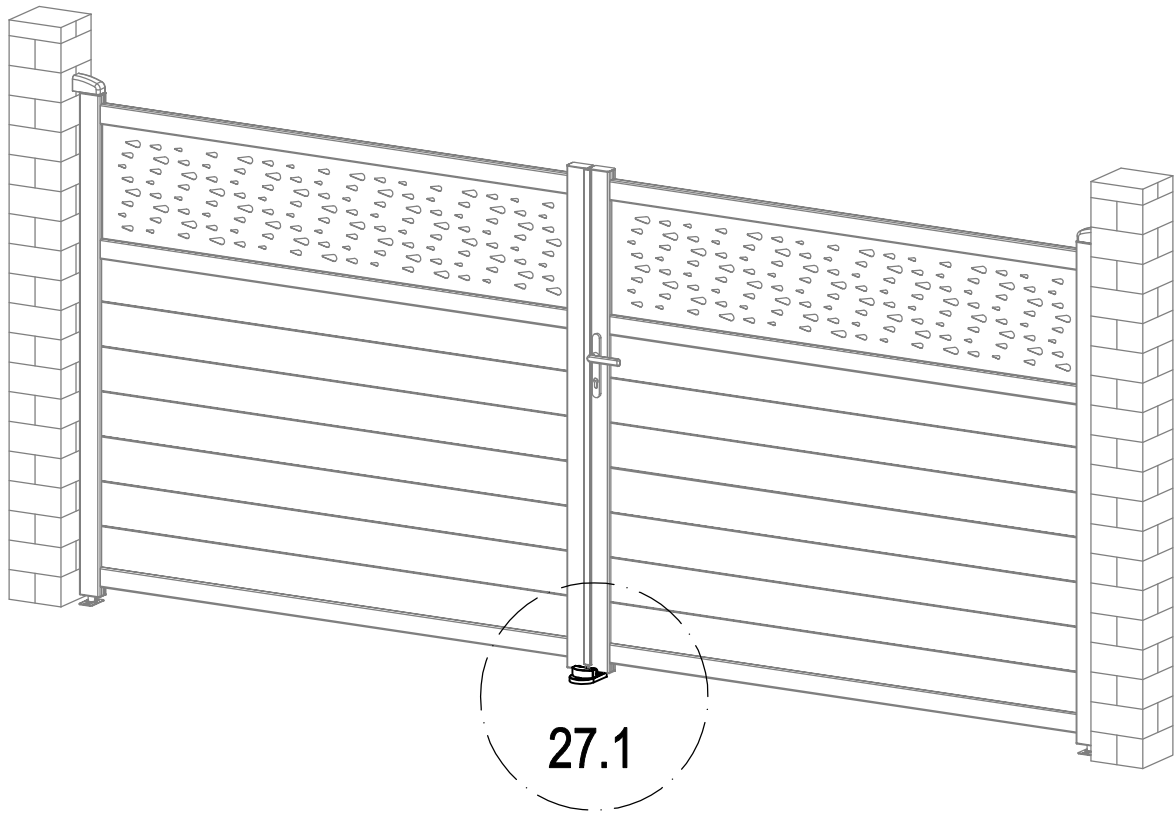

	Dr-15	2
	Dr-31	4

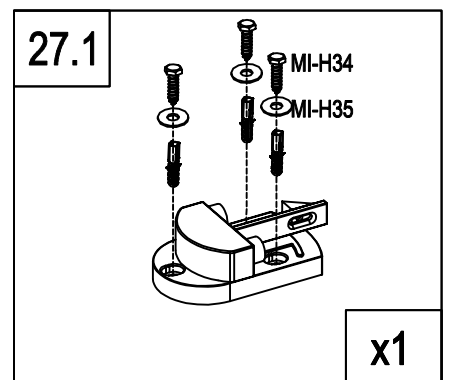

	Dr-16	1
	MI-H34	3
	MI-H35	3

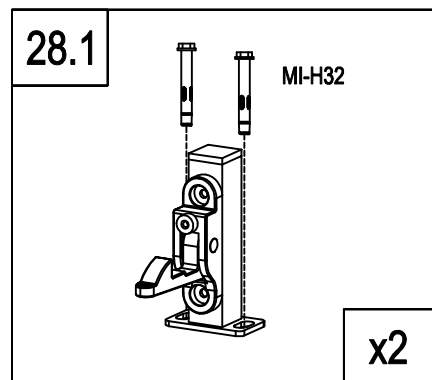
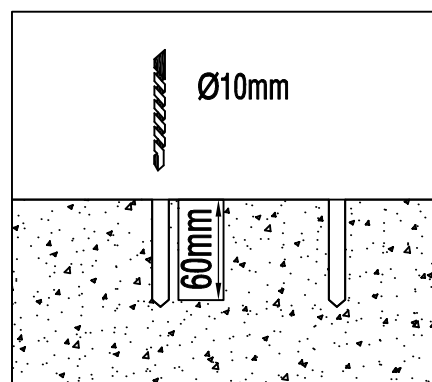
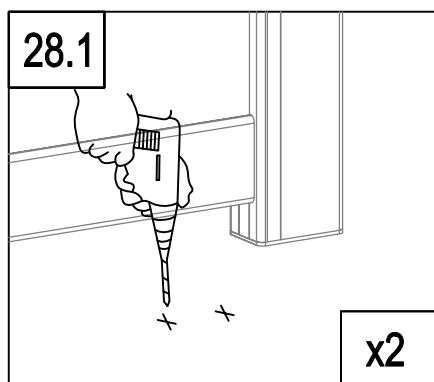
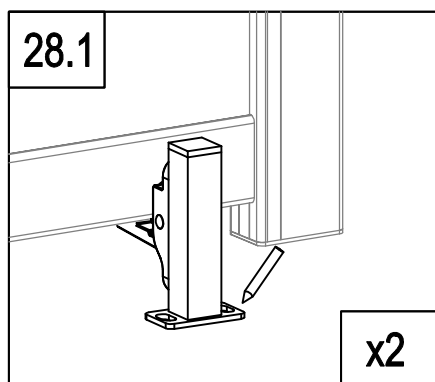
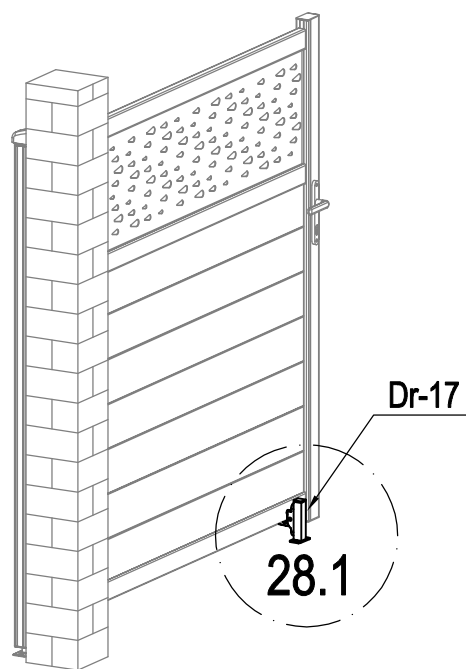
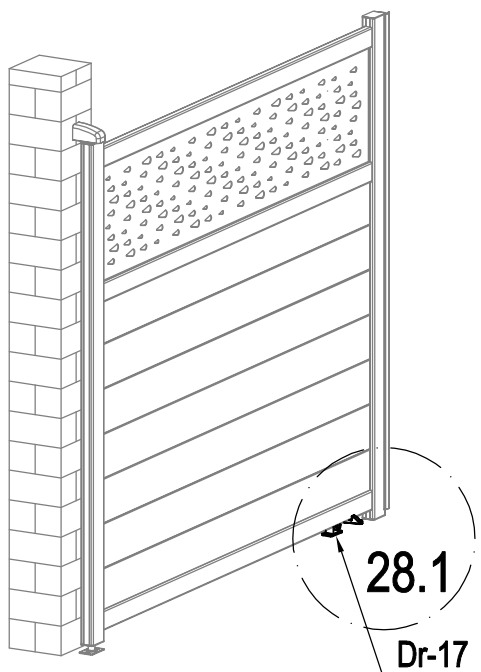



	MI-H32	4
	Dr-17	2



Vente-unique^{.com}

VS-Nov-2023

Imported by - Importé par
VENTE-UNIQUE.COM
9 Rue Jacquart 93310 Le Pré-Saint-Gervais
Made in China/ Fabriqué en Chine