

FR Description du produit
EN Product description
DE Produktbeschreibung
ES Descripción del producto

IT Descrizione del prodotto
NL Productomschrijving
PT Descrição do produto

CADRE A LATTES

DJ-PK02

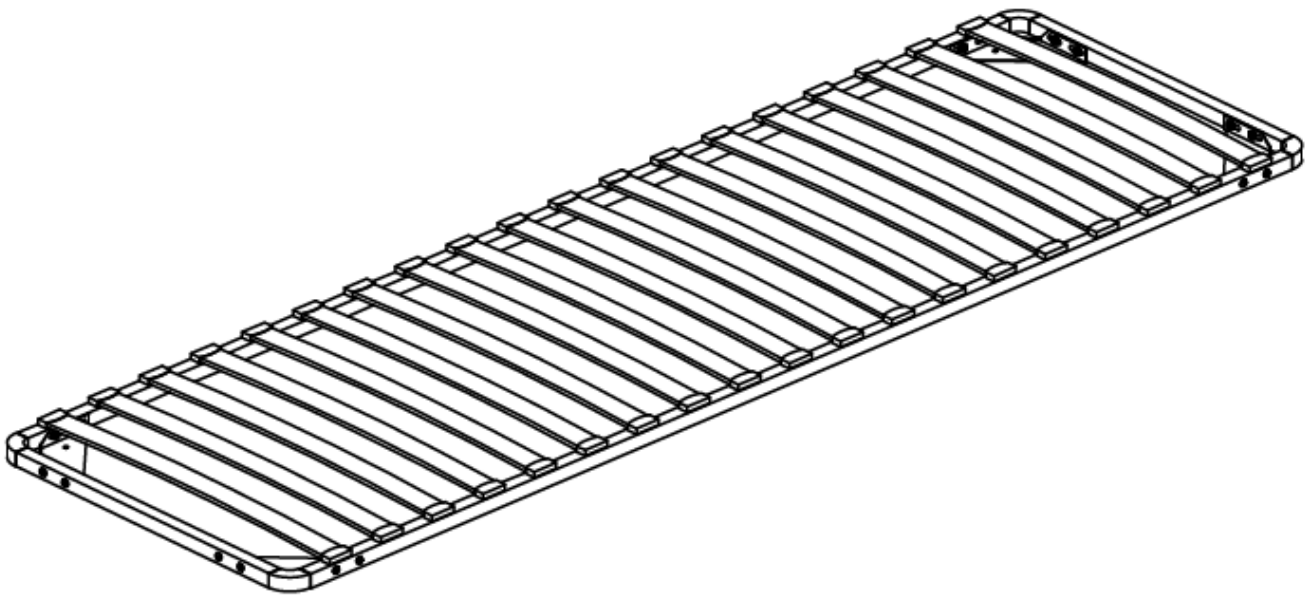

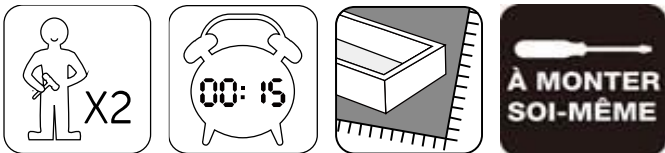

Meuble à usage domestique / Domestic furniture / Meuble a uso domestico / Möbel für den häuslichen Wohngebrauch/
Mobili per la casa/ Huishoudmeubilair / Mobiliário doméstico

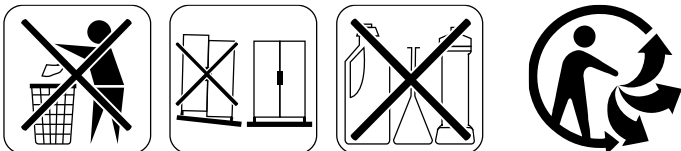

1. Reperez les pieces constituant votre meuble.
2. Regroupez et comptez la quincaillerie.
3. Munissez vous de l'outillage necessaire.
4. Amenez vous une zone de montage, la moquette ou une couverture protegera des rayures.
5. Procédez au montage, ne jamais forcer sur les assemblages, resserez les vis apres quelques temps d'usage.



FR

Gardez votre notice de montage.

Si une piece venait a manquer elle sera le moyen le plus clair pour communiquer avec votre magasin.
Nous conseillons d'aérer la pièce lors du montage et quelques heures après.

1. Identify the parts which make up your piece of furniture.
2. Gather the hardware parts and count them.
3. Have the necessary tools ready.
4. Organize a space for assembly, wall carpeting or a blanket will protect the furniture against scratches.
5. Mount the furniture, never force the parts to be assembled.



EN

Tighten the screws after it has been used for some time.

Keep the assembly instruction since it will help you when you get in touch with the store if a part should be missing.

We advise ventilating the room during installation and during few hours after.

1. Bitte überprüfen Sie, ob alle Einzelteile Ihres Möbelstücks vorhanden sind.
2. Bitte überprüfen Sie, ob alle Schrauben und Verbindungsteile für die Montage vorhanden sind.
3. Halten sie alle notwendigen Montage-Werkzeuge für ihren Einsatz gebrauchsbereit.
4. Bereiten Sie einen passenden Ort für die Montage vor. Ein Teppichboden oder ähnliches schützt vor Kratzern.
5. Beginnen Sie mit der Montage. Lassen Sie sich Zeit und fügen Sie die Einzelteile nie mit Gewalt zusammen.



DE

Um einen langfristigen und einwandfreien Gebrauch zu gewährleisten, ziehen Sie die einzelnen Schrauben regelmäßig nach längerer Nutzung des Möbelstücks fest.

Bitte bewahren Sie diese Montageanleitung auf. Diese gewährleistet im Problemfall einen reibungslosen und schnellen Kommunikationsaustausch mit dem Kundenservice Ihres Geschäfts.

Wir beraten, lüften Sie den Raum während der Installation und ein paar Stunden später.

1. Localice las piezas que componen su mueble.
2. Reagrupe y cuente la tornillería.
3. Prepare las herramientas necesarias.
4. Prepare una zona de montaje, la moqueta o una manta protegerá de arañazo.
5. Proceda al montaje, no forzar sobre los embalajes, apretar los tornillos después de algún tiempo de uso.



ES

Guardar las instrucciones de montaje.
Si una pieza le faltase, será la manera más fácil de comunicarse con su proveedor.
Aconsejamos ventilar la zona durante la instalación y algunas horas después.

1. Identificare le parti che componono il mobile.
2. Raccogliere le parti e contarle.
3. Tenere pronti gli attrezzi necessari.
4. Organizzare uno spazio per il montaggio, un telo da parete o una coperta proteggerà i mobili contro i graffi.
5. Montare il mobile, non forzare mai le parti da assemblare.



IT

Serrare le viti dopo che sono state usate per un certo periodo di tempo.
Conservare le istruzioni di montaggio poiché vi torneranno utili quando ricontatterete il negozio se una parte dovesse mancare.
Si consiglia di ventilare la stanza durante l'installazione e durante le ore successive.

1. Identificeer de onderdelen waar uw stuk meubilair uit bestaat.
2. Verzamel de hardwareonderdelen en tel deze.
3. Heb het vereiste gereedschap bijdehand.
4. Organiseer een ruimte voor assemblage; muurtapijt of een deken zal het meubilair beschermen tegen krassen.
5. Monteer het meubilair en forceer hierbij nooit de te monteren onderdelen.



NL

Draai de schroeven vast nadat het een tijdje in gebruik is geweest.
Bewaar de assemblage-instructies in het geval dat u contact op moet nemen met de winkel indien er een onderdeel ontbreekt.
Wij raden u aan de kamer te ventileren tijdens en voor enkele uren na de installatie.

1. Identifique as peças que constituem a sua mobília.
2. Junte as ferragens e conte.
3. Tenha prontas as ferramentas necessárias.
4. Organize e arranje espaço para a montagem, colocando um tapete ou manta para proteger a mobília contra riscos.
5. Monte a mobília, nunca force as peças a montar.



PT

Aperte os parafusos após a peça de mobília ter sido utilizada durante algum tempo.
Guarde as instruções de montagem, pois serão úteis quando quiser contactar a loja, caso perca alguma peça.
Aconselhamos a ventilar a divisão durante a instalação e algumas horas depois.

IMPORTANT, A CONSERVEZ POUR UNE REFERENCE ULTERIEURE: LIRE

ATTENTIVEMENT

IMPORTANT, RETAIN FOR FUTURE REFERENCE: READ CAREFULLY

WICHTIG, FÜR SPÄTERES NACHSCHLAGEN AUFBEWAHREN: SORGFÄLTIG

LESEN

IMPORTANTE, CONSERVAR PARA FUTURAS CONSULTAS: LEER

ATENTAMENTE







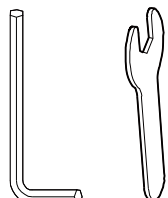

IMPORTANTE, CONSERVARE PER RIFERIMENTO FUTURO, LEGGERE CON

ATTENZIONE**BELANGRIJK, BEWAARALS EVENTUEEL NASLAGWERK, ZORGVULDIG
LEZEN****IMPORTANTE, GUARDAR PARA REFERÊNCIA FUTURA, LER ATENTAMENTE**

TOOLS

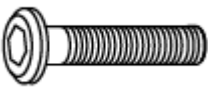

Hardware	Ctn No.	1
----------	---------	---

No.	Description	Size	Picture	Qty	Ctn no.
A	Front/Back Rail			2	1/1
B	Side Rail			2	1/1
C	Bracket			4	1/1
D	Plastic Corner			4	1/1
E	Slat			19	1/1
F	Plastic cap			38	1/1
G	Screw	M8*40		16	1/1
H	Nut	M8		16	1/1

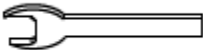
I	ALLEN KEY			1	1/1
J	Wrench			1	1/1

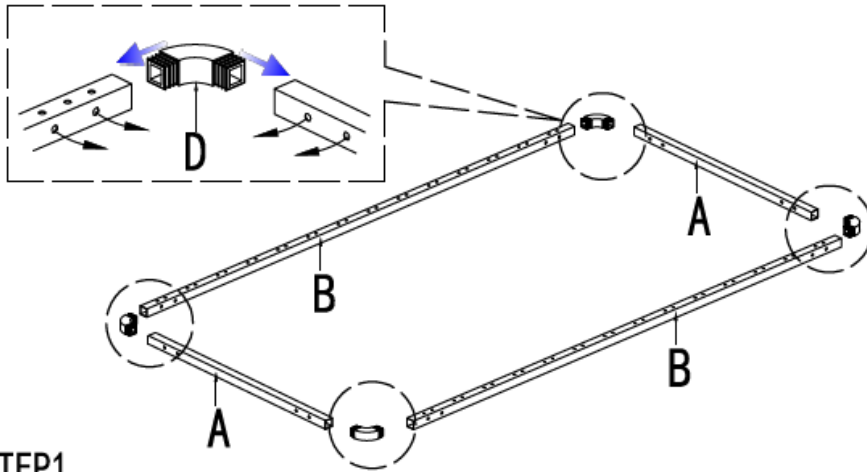

STEP1

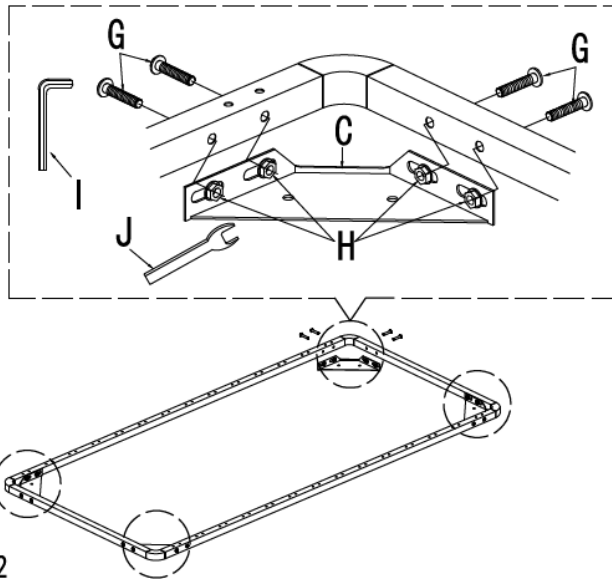

STEP2

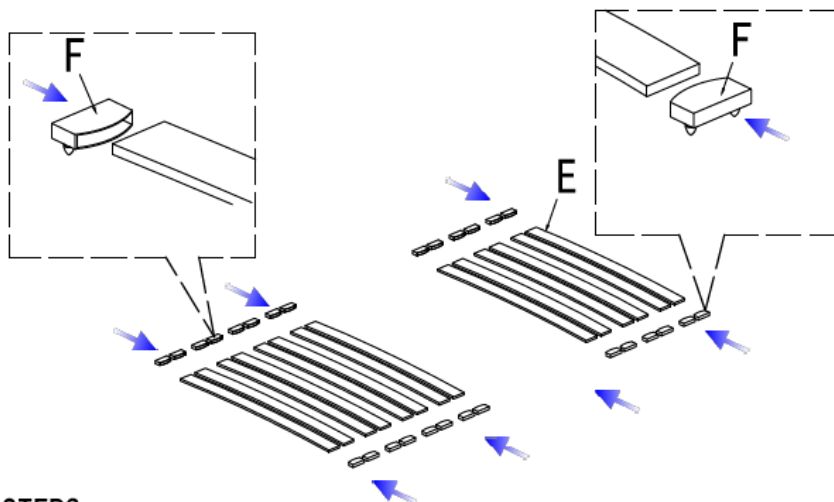

STEP3:

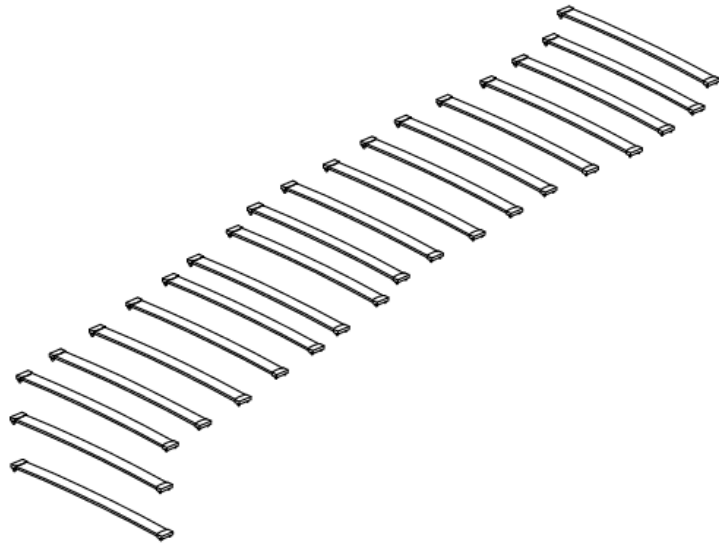

STEP4:

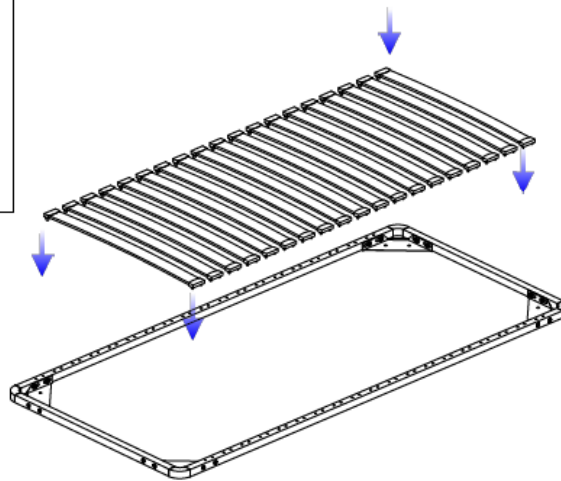
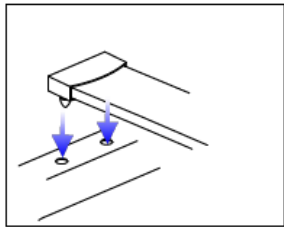

STEP5:

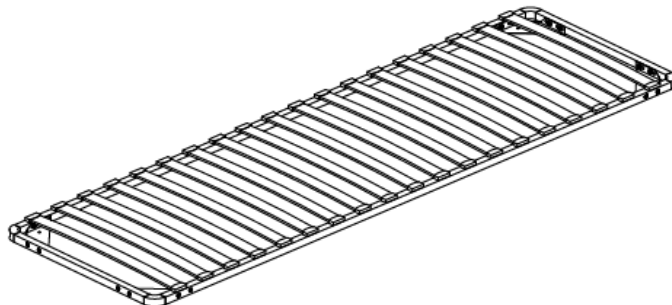

FINISH

Dépoussiérer régulièrement avec un chiffon sec.

Nettoyer avec du liquide vaisselle et essuyer avec un chiffon humide.

Ne pas utiliser le produit si l'un des éléments semble endommagé, brisé ou manque.

Eviter de placer ce produit à proximité de feu ouvert et d'autres sources de forte chaleur telle qu'un radiateur.

Care and maintenance:

Remove dust regularly with a dry cloth.

Clean with dishwashing liquid and wipe with a damp cloth.

Do not use the product if any part appears damaged, broken or missing.

Be aware of the risk of open fire and other sources of strong heat, such as electric heaters, in the vicinity of the product.

Pflege und Wartung:

Entfernen Sie den Staub regelmäßig mit einem trockenen Tuch.

Reinigen Sie mit Spülmittel und wischen Sie mit einem feuchten Tuch.

Verwenden Sie das Produkt nicht, wenn Teile beschädigt, defekt sind oder fehlen.

Achten Sie auf die Gefahr von Feuer und anderen starken Wärmequellen in der Nähe des Produkts, wie elektrische Heizkörper.

Cuidado y mantenimiento:

Quite el polvo periódicamente con un paño seco.

Limpiar con líquido para lavar platos y limpie con un paño húmedo.

No utilice el producto si alguna de las piezas está dañada, rota o falta.

Conozca los riesgos de un fuego y de otras fuentes de calor fuerte, como los calefactores eléctricos, en las proximidades del producto.

Cura e manutenzione:

Rimuovere la polvere regolarmente con un panno asciutto.

Pulire con detersivo per piatti e asciugare con un panno umido.

Non utilizzare il prodotto se una parte risulta danneggiata, rotta o mancante.

Essere consapevoli del rischio rappresentato da un camino e da altre fonti di forte calore, come riscaldatori elettrici, in prossimità del prodotto.

Onderhoud en reiniging:

Verwijder regelmatig enigerlei stof met een droge doek.

Reinig met afwasmiddel en veeg af met een vochtig doekje.

Gebruik het product niet als enigerlei onderdelen beschadigd lijken, gebroken zijn of ontbreken.

Houd rekening met de risico's van open vuur en andere krachtige hittebronnen, zoals elektrische verwarmingen, in de buurt van het product.

Cuidado e manutenção:

Remova frequentemente a poeira com um pano seco.

Limpe com detergente da loiça e um pano humedecido.

Não utilize o produto se alguma peça parecer danificada, partida ou em falta.

Tenha em atenção o risco de chama viva e de outras fontes de calor forte, como aquecedores elétricos, perto do produto.



VS-NOV-2020

FR Description du produit
EN Product description
ES Descripción del producto
DE Produktbeschreibung

IT Descrizione del prodotto
NL Productomschrijving
PT Descrição do produto
PL Opis produktu

Matelas

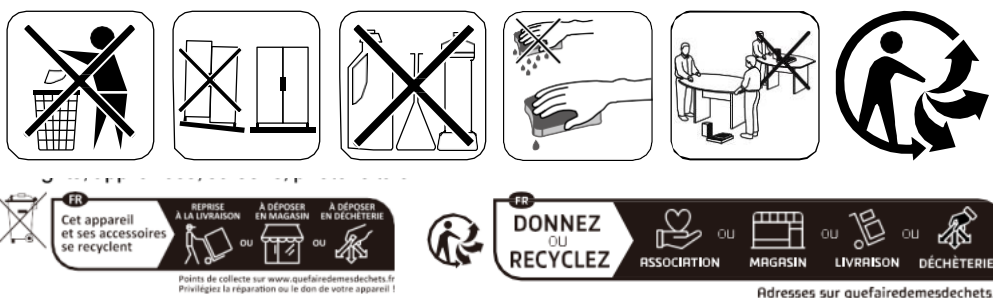

Vente-unique.com

Français (FR)

Lisez attentivement cette notice avant d'utiliser le matelas.

- Conservez cette notice pour référence future.
- Ne laissez pas les sacs en plastique à portée des enfants. Risque d'étouffement.
- Déballez le matelas dans une pièce bien ventilée.
- Respecter le temps de décompression de 72 heures avant utilisation.
- Déployez le matelas sur une surface plane et propre.
- Assurez-vous que le matelas soit correctement positionné sur le support recommandé.
- Ne placez pas le matelas près d'une flamme ouverte ou d'une source de chaleur.

English (EN)

Read this manual carefully before using the mattress.

- Keep this manual for future reference.
- Do not leave plastic bags within the reach of children. Risk of suffocation.
- Unpack the mattress in a well-ventilated room.
- Allow 72 hours for decompression before use.
- Place the mattress on a clean, flat surface.
- Ensure the mattress is properly positioned on the recommended support.
- Do not place the mattress near an open flame or heat source.

Deutsch (DE)

Lesen Sie diese Anleitung sorgfältig durch, bevor Sie die Matratze verwenden.

- Bewahren Sie diese Anleitung für zukünftige Referenz auf.
- Plastiktüten nicht in Reichweite von Kindern lassen. Erstickungsgefahr.
- Packen Sie die Matratze in einem gut belüfteten Raum aus.
- Lassen Sie die Matratze 72 Stunden zur Entfaltung ruhen, bevor Sie sie verwenden.
- Legen Sie die Matratze auf eine saubere, ebene Fläche.
- Stellen Sie sicher, dass die Matratze korrekt auf der empfohlenen Unterlage positioniert ist.
- Platzieren Sie die Matratze nicht in der Nähe von offenen Flammen oder Wärmequellen.

Italiano (IT)

Leggere attentamente queste istruzioni prima di utilizzare il materasso.

- Conservare queste istruzioni per riferimento futuro.
- Non lasciare i sacchetti di plastica alla portata dei bambini. Rischio di soffocamento.
- Disimballare il materasso in una stanza ben ventilata.
- Attendere 72 ore per la decompressione prima dell'uso.
- Posizionare il materasso su una superficie piana e pulita.
- Assicurarsi che il materasso sia correttamente posizionato sul supporto raccomandato.
- Non posizionare il materasso vicino a fiamme libere o fonti di calore.

Español (ES)

Lea atentamente este manual antes de usar el colchón.

- Conserve este manual para futuras consultas.
- No deje bolsas de plástico al alcance de los niños. Riesgo de asfixia.
- Desempaque el colchón en una habitación bien ventilada.
- Espere 72 horas para que el colchón se descomprima antes de usarlo.
- Coloque el colchón sobre una superficie limpia y plana.
- Asegúrese de que el colchón esté correctamente colocado sobre el soporte recomendado.

- No coloque el colchón cerca de llamas abiertas o fuentes de calor.
-

Português (PT)

Leia atentamente este manual antes de usar o colchão.

- Guarde este manual para referência futura.
 - Não deixe sacos plásticos ao alcance de crianças. Risco de asfixia.
 - Desembale o colchão em um local bem ventilado.
 - Aguarde 72 horas para a descompressão antes de usar.
 - Coloque o colchão sobre uma superfície limpa e plana.
 - Certifique-se de que o colchão esteja corretamente posicionado no suporte recomendado.
 - Não coloque o colchão próximo a chamas abertas ou fontes de calor.
-

Polski (PL)

Przeczytaj uważnie tę instrukcję przed użyciem materaca.

- Zachowaj tę instrukcję na przyszłość.
 - Nie pozostawiaj plastikowych toreb w zasięgu dzieci. Ryzyko uduszenia.
 - Rozpakuj materac w dobrze wentylowanym pomieszczeniu.
 - Odczekaj 72 godziny na pełne rozłożenie przed użyciem.
 - Umieść materac na czystej i płaskiej powierzchni.
 - Upewnij się, że materac jest prawidłowo umieszczony na zalecanym podparciu.
 - Nie umieszczaj materaca w pobliżu otwartego ognia ani źródeł ciepła.
-

Nederlands (NL)

Lees deze handleiding zorgvuldig door voordat u de matras gebruikt.

- Bewaar deze handleiding voor toekomstig gebruik.
- Laat plastic zakken niet binnen het bereik van kinderen. Verstikkingsgevaar.
- Pak de matras uit in een goed geventileerde ruimte.
- Laat de matras 72 uur decomprimeren voordat u deze gebruikt.
- Leg de matras op een schone, vlakke ondergrond.
- Zorg ervoor dat de matras correct is geplaatst op het aanbevolen ondersteuningssysteem.
- Plaats de matras niet in de buurt van een open vlam of warmtebron.

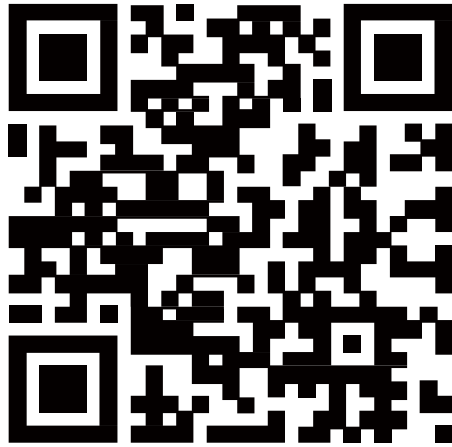

Vente-unique.com

VS-Jul-2024

Imported by - Importé par

CAFOM DISTRIBUTION

9 Rue Jacquart 93310 Le Pré-Saint-Gervais

TRASMAN

DESIGNED & MADE IN
100%
BARCELONA

MANUAL DE MONTAJE
NOTICE DE MONTAGE
ASSEMBLY MANUAL
MANUALE PER IL MONTAGGIO
MONTAGEANLEITUNG
MANUAL DE MONTAGEM
INSTRUKCJE MONTAŻOWE

1960 SACHA

V.01 - 05/23

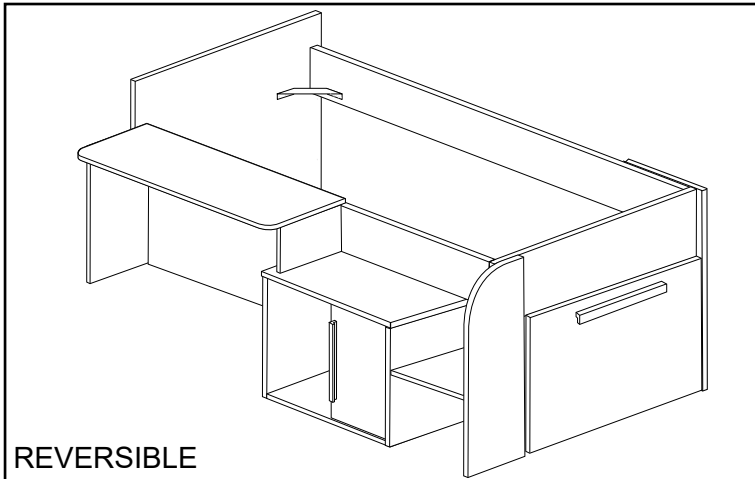

REVERSIBLE



≈ 2h



x2

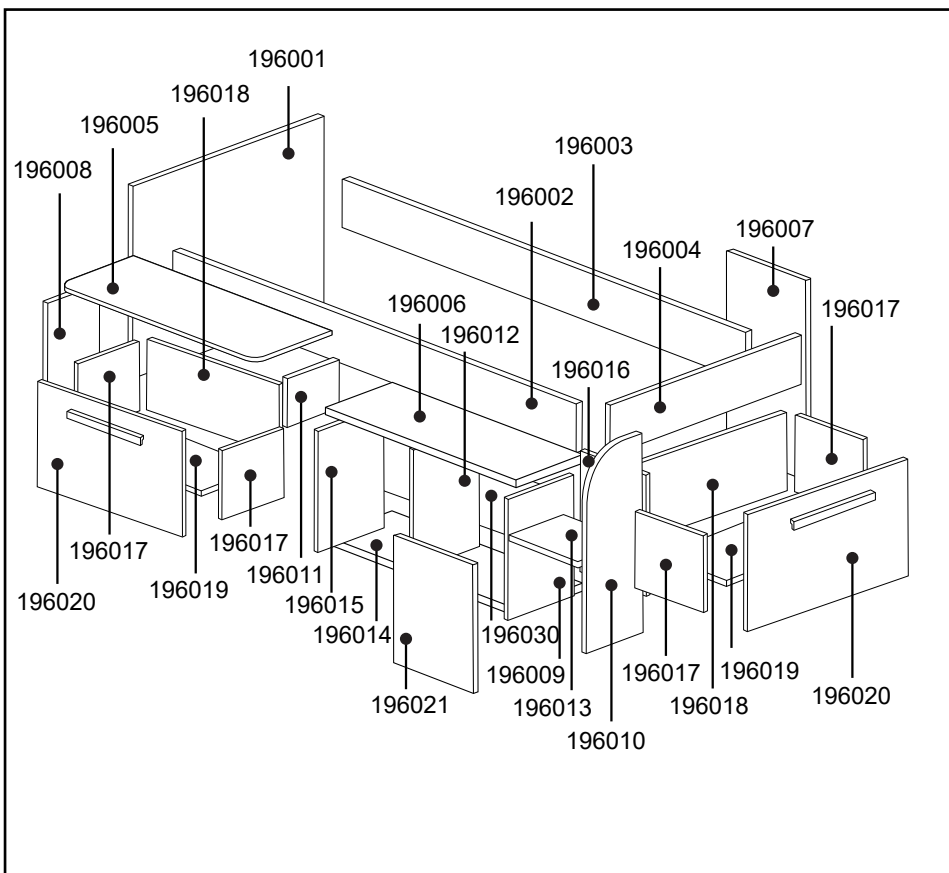
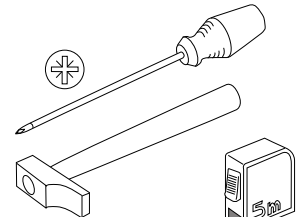

ANTES DE EMPEZAR CONSULTE LOS CONSEJOS PARA EL MONTAJE.

AVANT DE COMMENCER CONSULTEZ LES INSTRUCTIONS DE MONTAGE.











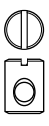



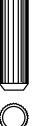

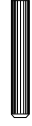













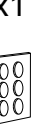
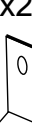

BEFORE STARTING REFER TO THE ASSEMBLY ADVICE.

PRIMA DI INIZIARE LEGGERE I CONIGLI PER IL MONTAGGIO.

VOR DEM BEGINN EMPFIEHLT ES SICH AUFMERKSAM DIE HINWEISE ZUR MONTAGE ZU LESEN.

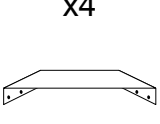
ANTES DE COMEÇAR CONSULTE OS CONSELHOS PARA A MONTAGEM.

ZANIM PRZYSTAPIMY DO MONTAZU, PROSIMY ZAPOZNAC SIE Z NASTĘPUJACYMI WSKAZÓWKAMI.

x8  TM660A	x8  TUEM61013	x18 	x18  EX16	x12  TSM	x26  CL830	x4  SKM16	x4  TCK0311	x6  CL1060	x28  TA550	x1  LLA3	x4  TP3540	x2  TM630A	x2  CM670	x4  TV3135	x44  TP3515	x3  TCA4030	x6  AAM220	
x2  TA760	x1  LLA4	x2  TP3530	x4  TP4016	x8  RTC24	x1  COLA	x30  P1030	x1  CT715	x2  E2137	x2  B35A	x2  BA35S	x10  TA3RK	x8  TE17RK	x2  TA4RK	x2  T8BL	x4  ESJ	x22  TA3BL	x10  TE17BL	x6  T10RK

ESPAÑOL

CONSEJOS PARA EL MONTAJE:

- 1-ESTUDIE ATENTAMENTE EL MANUAL DE MONTAJE.
- 2-LOCALICE LAS PIEZAS QUE CONSTITUYEN SU MUEBLE.
- 3-REUNA Y CONTROLE LOS HERRAJES SUMINISTRADOS.
- 4-EQUIPESE CON LAS HERRAMIENTAS NECESARIAS.
- 5-PREPARE UNA ZONA DE MONTAJE.

CONSEJOS PARA EL MANTENIMIENTO:

- 1-QUITAR EL POLVO CUIDADOSAMENTE.
- 2-HUMEDECER UN PAÑO SUAVE Y LIMPIO CON AGUA LIGERAMENTE ENJABONADA.

NO FUERCE NUNCA EN LAS UNIONES APRIETE LOS TORNILLOS DESPUES DE CIERTO TIEMPO DE UTILIZACION.
CONSERVE SU MANUAL DE MONTAJE.SI FALTARA UNA PIEZA SERIA LA MANERA MAS FACIL DE COMUNICARLO A LA TIENDA.

NO USE NUNCA PRODUCTOS ABRASIVOS TALES COMO:
LANA DE ACERO , LIJAS,DISOLVENTES,ETC.
NO MOJAR NI SOMETER A GRANDES HUMEDADES AL MUEBLE.

FRANCAIS

INSTRUCTIONS DE MONTAGE:

- 1-LISEZ ATTENTIVEMENT LA NOTICE DE MONTAGE.
- 2-REPEREZ LES PIECES QUI COMPOSENT VOTRE MEUBLE.
- 3-REGROUPEZ ET VERIFIEZ LES FERRURES FOURNIES.
- 4-DOTEZ-VOUS DES OUTILS NECESSAIRES.
- 5-PREPAREZ UN ESPACE DE MONTAGE.

CONSEILS D'ENTRETIEN:

- 1-ENLEVEZ SOIGNEUSEMENT LA POUSSIERE.
- 2-HUMIDIFIEZ UN CHIFFON DOUX ET PROPRE AVEC DE L'EAU LEGEREMENT SAVONNEUSE.

LES MEUBLES CONTENANT DES PANNEAUX À BASE DE BOIS (PANNEAUX DE PARTICULES, PANNEAUX DE FIBRES, CONTREPLAQUÉ...) PEUVENT ÉMETTRE DES SUBSTANCES POLLUANTES DANS L'AIR INTÉRIEUR. IL EST AINSI RECOMMANDÉ, APRÈS L'INSTALLATION DU MEUBLE DANS SON LOGEMENT, D'AÉRER FRÉQUEMMENT LA PIÈCE CONCERNÉE PENDANT AU MOINS QUATRE SEMAINES AFIN DE RÉDUIRE SON EXPOSITION AUX POLLUANTS ÉMIS PAR LE MEUBLE.

NE FORCEZ JAMAIS LES RACCORDS. RESSERREZ LES VIS APRES UN CERTAIN TEMPS D'UTILISATION.
CONSERVEZ LA NOTICE DE MONTAGE.EN CAS DE PIECE MANQUANTE , CE SERA LE MEILLEUR MOYEN D'EN INFORMER LE MAGASIN.

N'UTILISEZ JAMAIS DES PRODUITS ABRASIFS COMME DE LA LAINE D'ACIER, DU PAPIER DE VERRE, DES SOLVANTS, ETC.
NE MOUILLEZ PAS LE MEUBLE ET EVITEZ TOUTE ESPOSITION A UNE HUMIDITE IMPORTANTE.

DEUTSCH

HINWEISE ZUR MONTAGE:

- 1- LESEN SIE AUFMERKSAM DIE MONTAGEANLEITUNG DURCH.
- 2- LOKALISIEREN SIE DIE ZUM MÖBEL GEHÖRENDE TEILE.
- 3- KONTROLLIEREN SIE DIE MITGELIEFERTEN WERKZEUGE.
- 4- RÜSTEN SIE SICH MIT DEN ZUSÄTZLICH BENÖTIGTEN WERKZEUGEN AUS.
- 5- BEREITEN SIE EINEN PLATZ FÜR DIE MONTAGE VOR.

HINWEISE ZUR PFLEGE:

- 1- ENTFERNEN SIE UMSICHTIG DEN ANGESAMMELTEN STAUB.
- 2- VERWENDEN SIE EIN WEICHES UND SAUBERES TUCH UND SCHWACHE SEIFENLAUGE.

FORCIEREN SIE NIEMALS DIE VERBINDUNGEN. ZIEHEN SIE DIE SCHRAUBEN NACH EINER BESTIMMTEN NUTZUNGSZEIT NACH. BEWAHREN SIE DIE MONTAGEANLEITUNG AUF. SOLLTE EIN TEIL FEHLEN IST SIE VON GROSSER WICHTIGKEIT BEI DER NACHBESTELLUNG IM LADEN.

VERWENDEN SIE NIEMALS SCHEUERENDE PRODUKTE WIE STAHLWOLLE, SCHMIRGELPAPIER, LÖSUNGSMITTEL UND DERGL. WASSER UND HOHE FEUCHTIGKEIT SIND SCHÄDLICH FÜR DAS MÖBEL.

ITALIANO

CONSIGLI PER IL MONTAGGIO:

- 1- STUDIARE ATTENTAMENTE IL MANUALE DI MONTAGGIO.
- 2- INDIVIDUARE LE PARTI CHE COSTITUISCONO IL MOBILE.
- 3- RACCOGLIERE E CONTROLLARE GLI ATTREZZI IN DOTAZIONE.
- 4- PROCURARSI GLI ATTREZZI NECESSARI.
- 5- PREPARARE UNA ZONA PER IL MONTAGGIO.

CONSIGLI PER LA MANUTENZIONE:

- 1- SPOLVERARE ACCURATAMENTE.
- 2- INUMIDIRE UN PANNINO MORBIDO E PULITO CON ACQUA E POCO DETERGENTE.

NON FORZARE MAI LE GIUNTURE. STRINGERE NUOVAMENTE LE VITI DOPO UN CERTO PERIODO D'USO. CONSERVARE IL MANUALE DI MONTAGGIO: SE MANCASSE UN PEZZO SAREBBE COSÌ PIÙ FACILE COMUNICARLO AL RIVENDITORE.

NON USARE MAI PRODOTTI ABRASIVI COME: SPUGNE ABRASIVE, CARTA VETRATA, SOLVENTI, ECC.
NON BAGNARE NE' SOTTOPORRE IL MOBILE A FORTE UMIDITÀ.

POTUGUES

CONSELHO PARA A MONTAGEM :

- 1 - ESTUDE ATENTAMENTE O MANUAL DE MONTAGEM.
- 2 - LOCALIZE AS PEÇAS QUE CONSTITUEM O SEU MÓVEL.
- 3 - REUNA E CONTROLE AS FERRAGENS FORNECIDAS.
- 4 - EQUIPE-SE COM AS FERRAMENTAS NECESSÁRIAS.
- 5 - PREPARE UMA ZONA DE MONTAGEM.

CONSELHOS PARA A MANUTENÇÃO :

- 1- RETIRAR A POEIRA COM CUIDADO.
- 2- HUMEDECER UM PANO SUAVE E LIMPO COM ÁGUA LIGEIRAMENTE ENSABOADA.

NUNCA FORCE AS UNIÕES. APORTE OS PARAFUSOS DEPOIS DE DETERMINADO TEMPO DE UTILIZAÇÃO..
CONSERVE O SEU MANUAL DE MONTAGEM, SE FALTAR UMA PEÇA SERIA A MANEIRA MAIS FÁCIL DE A COMUNICAR À LOJA.

NUNCA USE PRODUTOS ABRASIVOS TAIS COMO : LÃ DE AÇO, LIXAS, DISSOLVENTES, ETC..
NÃO MOLAR NEM SUBMETER A GRANDES HUMIDADES, O MÓVEL.

POLSKU

WSKAZÓWKI ODNOSNIE MONTAZU:

1. PRZECZYTAĆ UWAGNIE NINIEJSZE ZALECENIA.
2. ZLOKALIZOWAĆ CZĘŚCI SKŁADOWE MEBLA.
3. ZEBRAĆ WSZYSTKIE ELEMENTY ŁĄCZĄCE.
4. ZAOPATRYĆ SIĘ W NIEZBEDNE NARZĘDZIA.
5. PRZYGOTOWAĆ ODPOWIEDNIE MIEJSCE NA MONTAZ.

WSKAZÓWKI ODNOSNIE KONSERWACJI:

1. ODKURZAC OSTROŻNIE.
2. W TYM CELU ZWILŻYC CZYSTĄ MIEKKA SZMATKĘ W SŁABYM ROZTWORZE WODY Z MYDŁEM.

NIE DOCISKAC NA SIŁE ELEMENTÓW ŁĄCZĄCYCH. DOKRECIĆ ŚRUBY PO UPLYWIE PEWNEGO CZASU.
ZACHOWAĆ INSTRUKCJE MONTAZOWE; W RAZIE BRAKU JAKIEJSZ CZĘŚCI, ULATWIA ONE KONTAKT ZE SPRZEDAWCĄ.

NIE NALEŻY NIGDY UŻYWAĆ ŚRODKÓW SZORUĄCYCH, TAKICH JAK WELNA STALOWA, PAPIER SCIERNY, ROZPUSZCZALNIKI ITP.
NIE MOCZYĆ ANI NIE PODDAWAĆ MEBLA DZIAŁANIU DUŻEJ WILGOTNOŚCI.

ENGLISH

ASSEMBLY ADVICE:

- 1- STUDY THE ASSEMBLY MANUAL CAREFULLY.
- 2- LOCATE THE PARTS THAT COMPRISE YOUR FURNITURE ITEM.
- 3- ORGANISE AND CHECK THE FITTINGS SUPPLIED.
- 4- HAVE THE NECESSARY TOOLS TO HAND.
- 5- PREPARE AN ASSEMBLY AREA.

MAINTENANCE ADVICE:

- 1- REMOVE DUST CAREFULLY.
- 2- MOISTEN A SOFT, CLEAN CLOTH WITH SLIGHTLY SOAPY WATER.

DO NOT FORCE ANY OF THE JOINTS. TIGHTEN THE SCREWS AFTER HAVING USED THE FURNITURE FOR SOME TIME.
KEEP YOUR ASSEMBLY MANUAL. IF ANY PART IS MISSING, IT WILL HELP YOU TO LET THE SHOP KNOW.

NEVER USE ABRASIVE PRODUCTS SUCH AS STEEL WOOL, SANDPAPER, ETC.
DO NOT WET THE FURNITURE OR KEEP IT IN A VERY DAMP PLACE.

HERRAJES

FERRURES

MÖBELBESCHLÄGE

ACCESSORI
PER MOBILI

FERRAGENS

OKUCIA
MEBLOWE

FURNITURE
FITTINGS

T1



x8

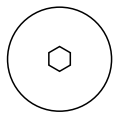
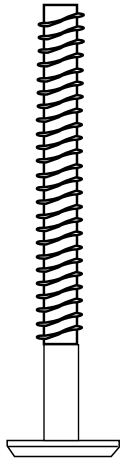

TM660A

x8

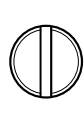

TUEM61013

x18

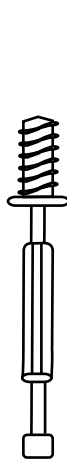

PE845

x18



EX16

T2



x12

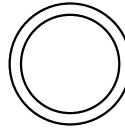
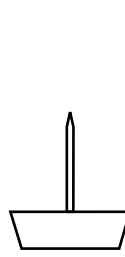

TSM

x26



CL830

x4

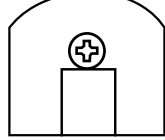
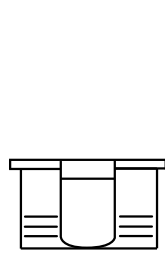

SKM16

x4



TCK0311

T3



x6

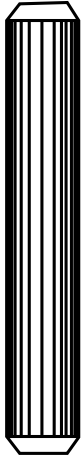

CL1060

x28

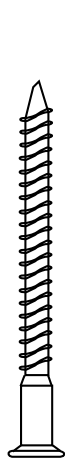

TA550

x1

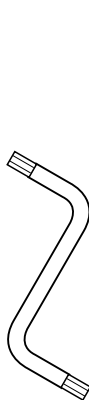

LLA3

x4



TP3540

T4



x2

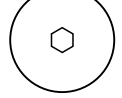
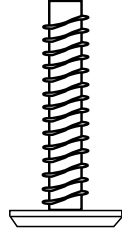

TM630A

x2

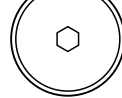
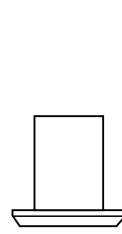

CM670

x4



TV3135

x44



TP3515

T5



x2

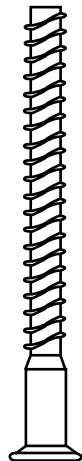

TA760

x1

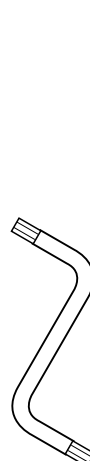

LLA4

x2



TP3530

x4



TP4016

Y



x2

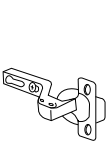

B35A

x2



BA35S

HERRAJES

FERRURES

MÖBELBESCHLÄGE

ACCESSORI
PER MOBILI

FERRAGENS

OKUCIA
MEBLOWE

FURNITURE
FITTINGS

T6

x10

x2

x6

x8

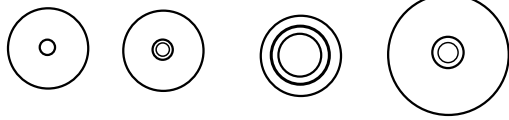
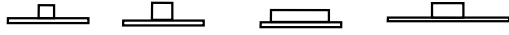

TA3RK

TA4RK

T10RK

TE17RK

T7

x22

x2

x10

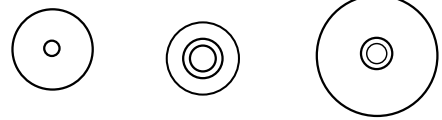

TA3BL

T8BL

TE17BL

X

x8

x1

x1

x1

x2

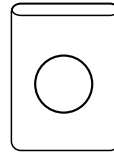
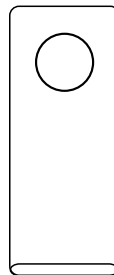
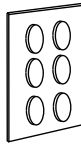
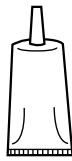
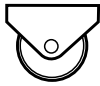

RTC24

P1030

COLA

CT715

E2137

AC

x4

x3



ESJ

AAM220

x6
TCA4030

1/4

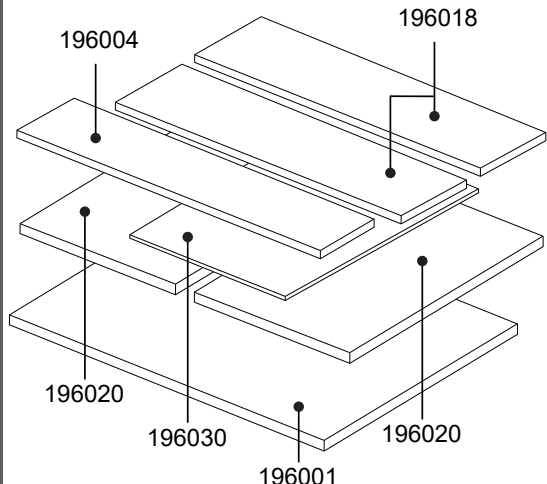

1960A

2/4



T1 T2
T3 T4
T5 T6
T7 X
Y AC

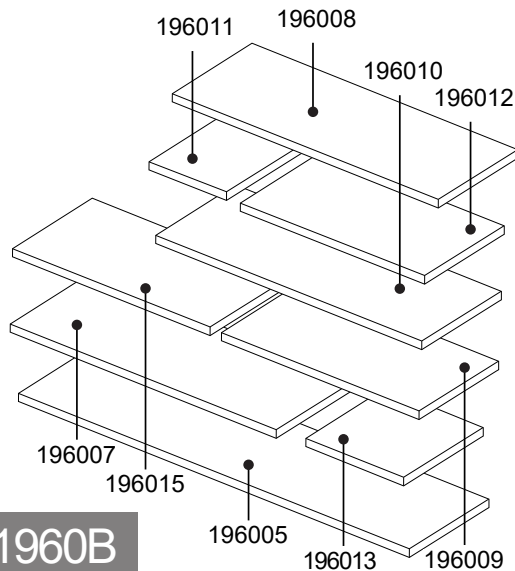

1960B

3/4

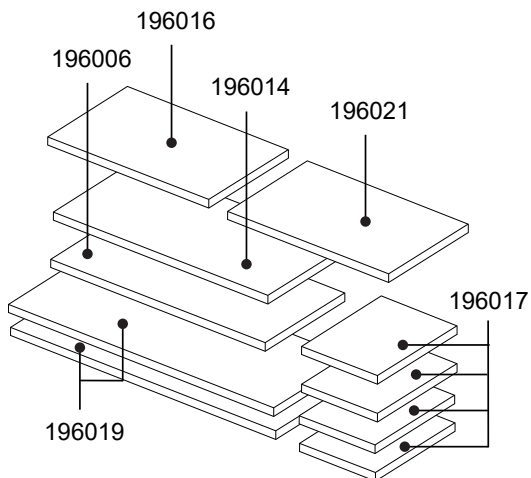

1960C

4/4

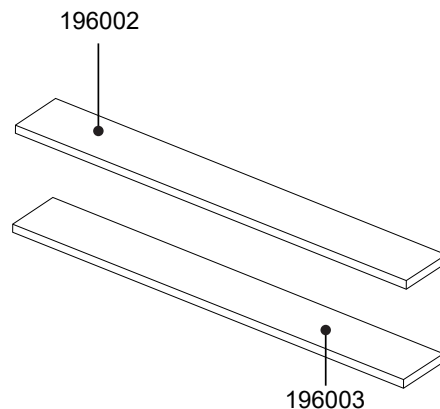

1960D

1

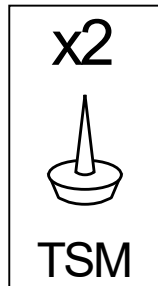
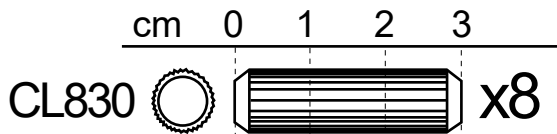
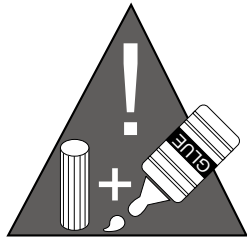
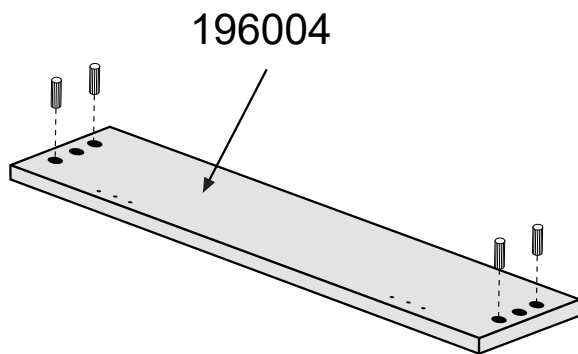
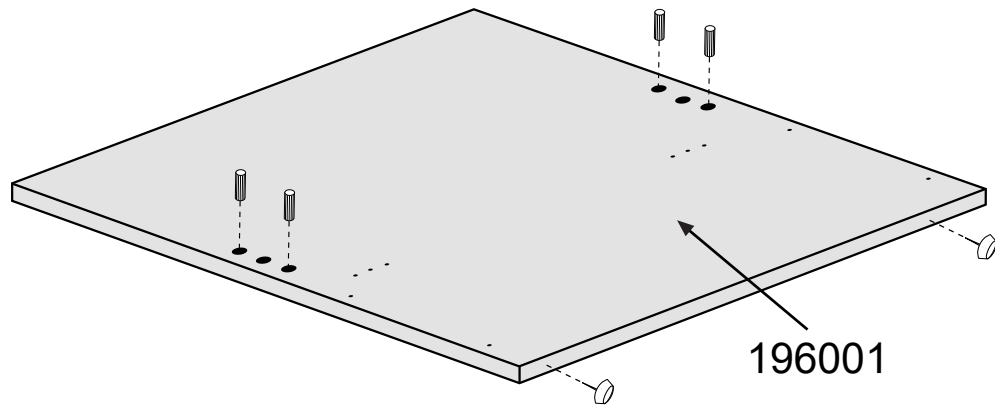

2

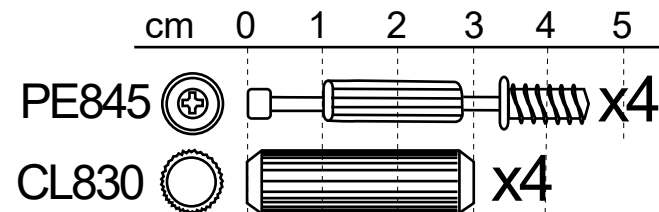
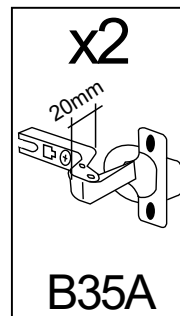
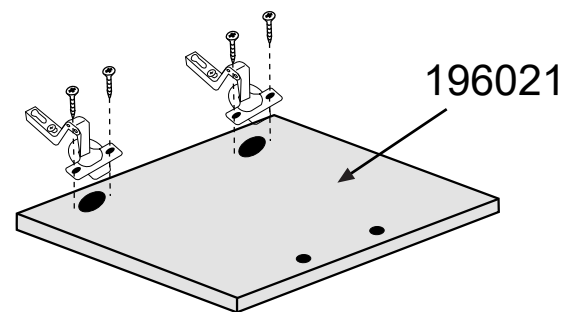
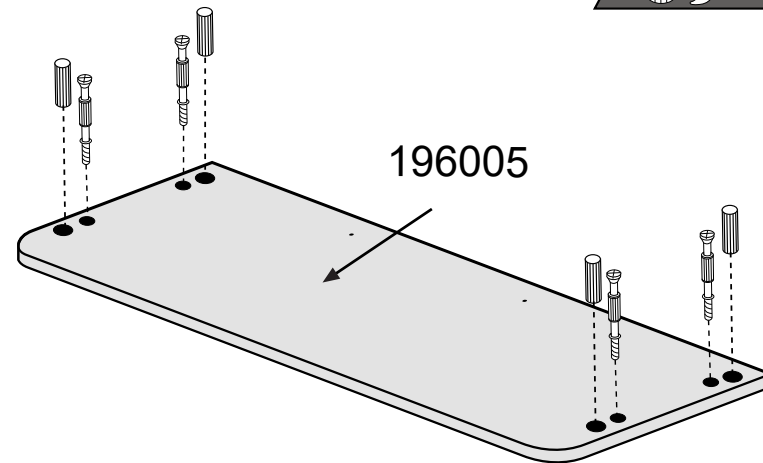
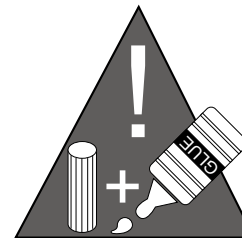
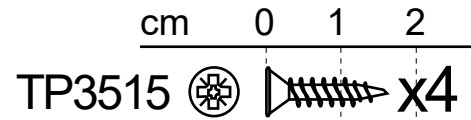

3

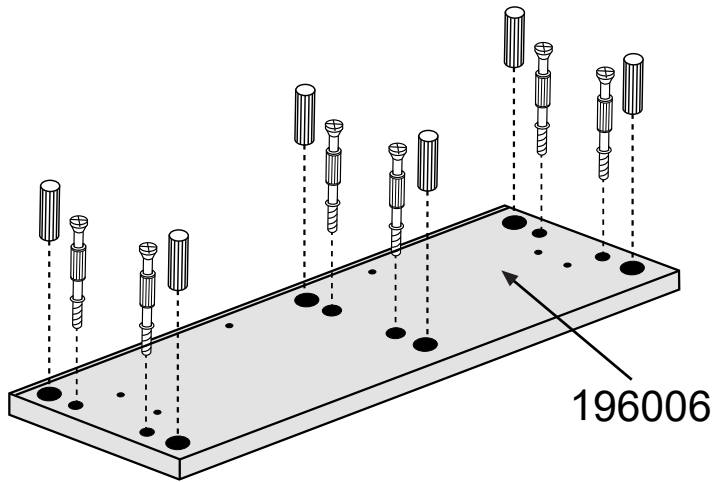
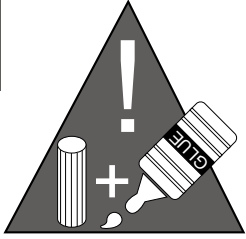

cm 0 1 2 3 4 5

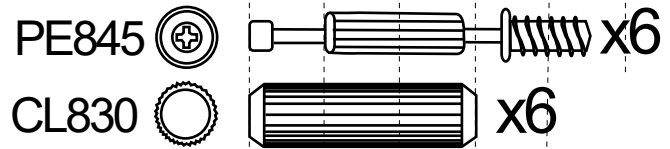

4

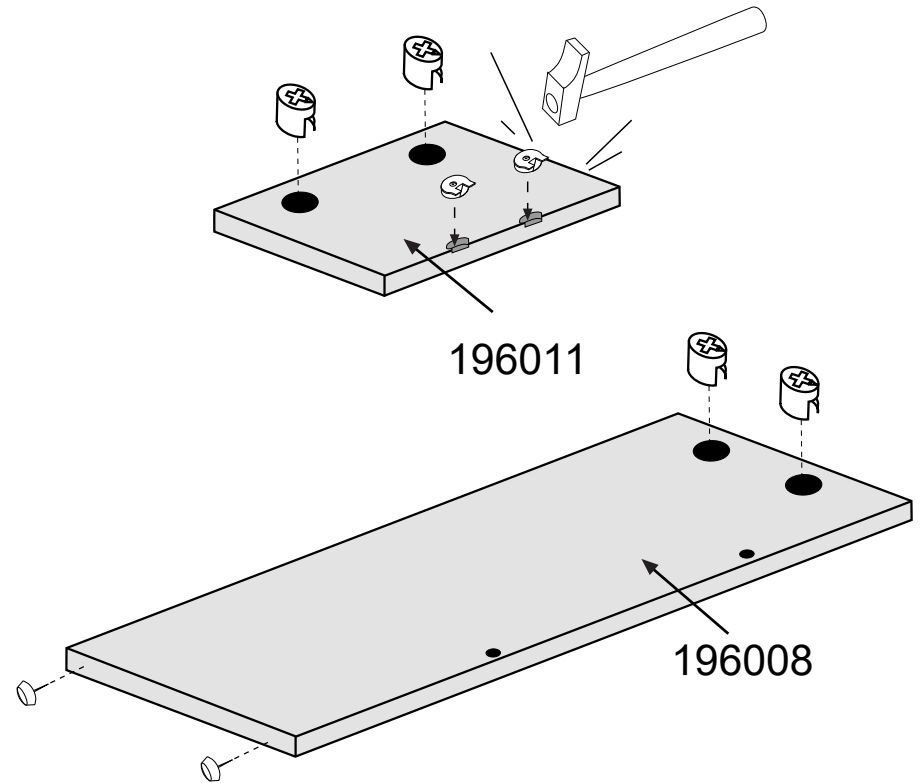
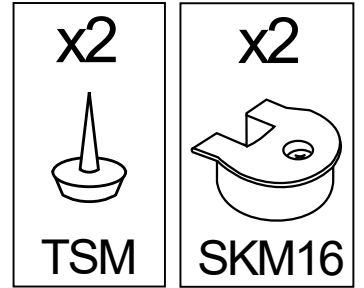

cm 0 1 2

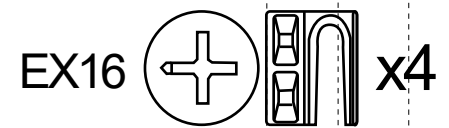

5

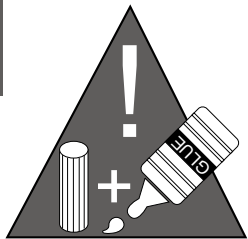

cm 0 1 2

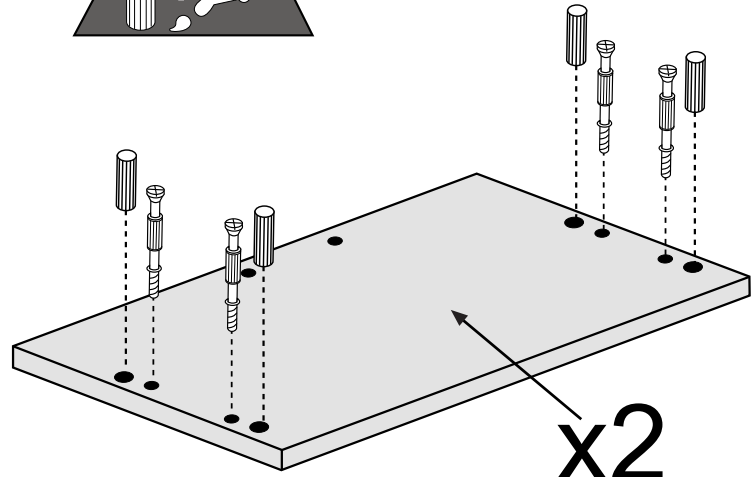

x2
196020

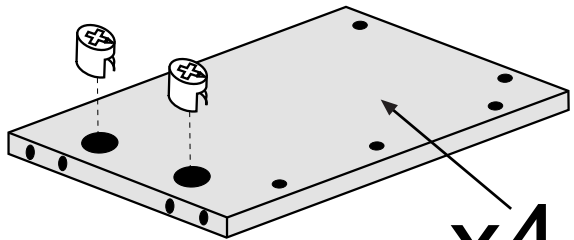

x4
196017

cm 0 1 2 3 4 5

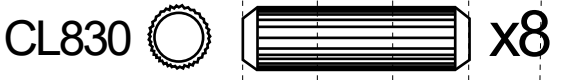
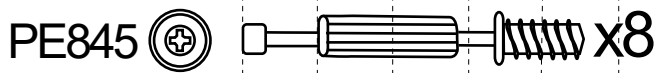

6

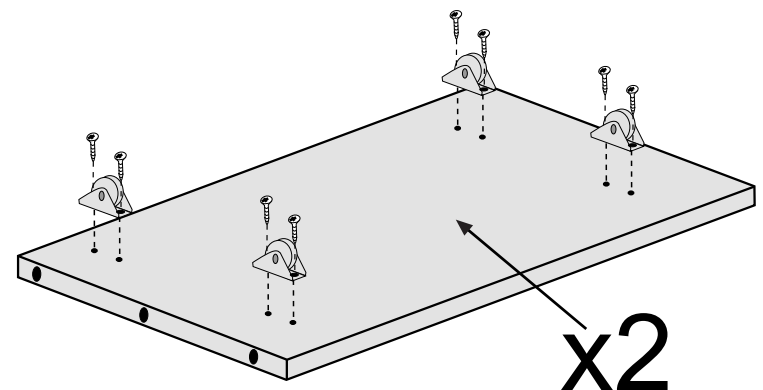
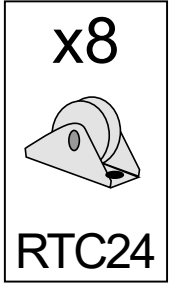

x2
196019

cm 0 1 2



7

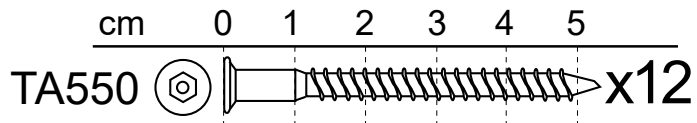
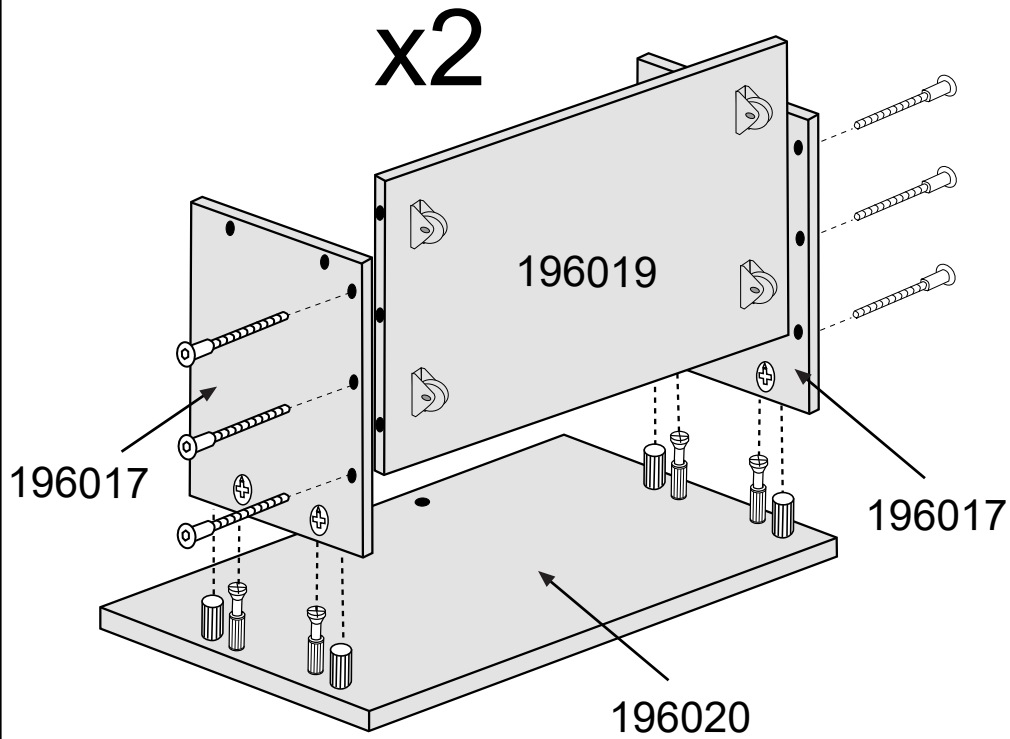
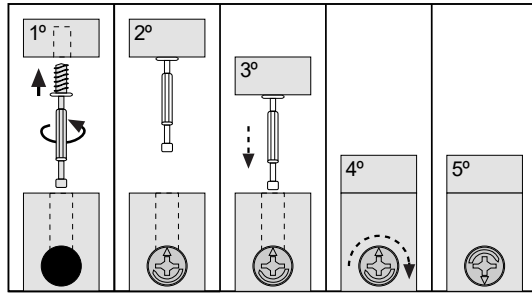
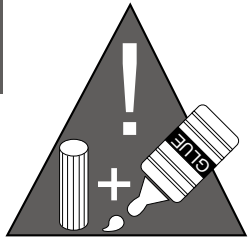

8

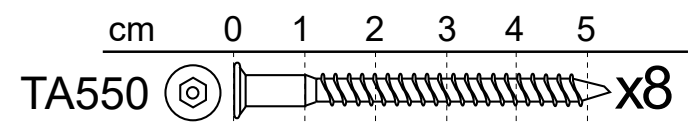
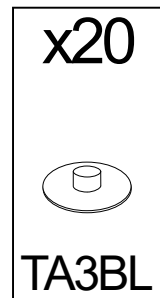
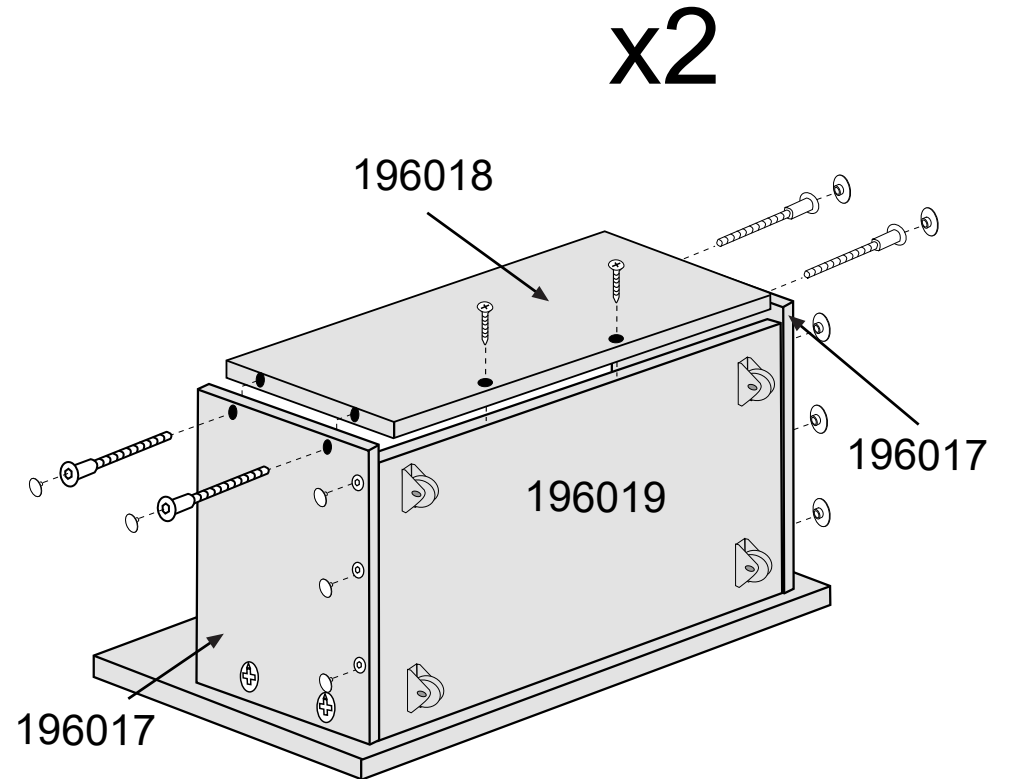
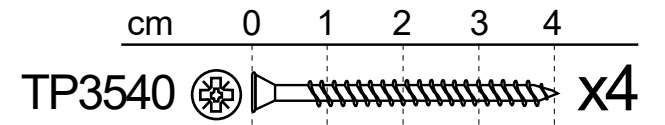

9

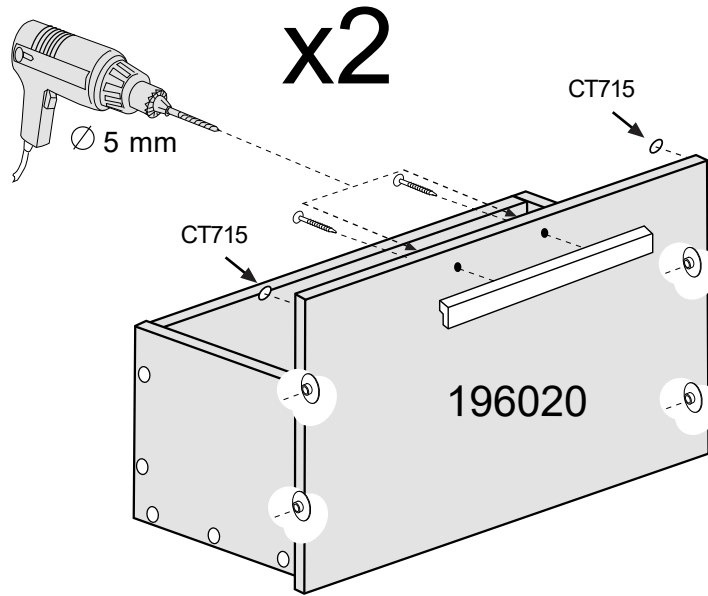

x2

CT715

∅ 5 mm

CT715

196020

x2



AAM220

x4

TCA4030

x1(4)

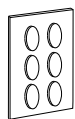

CT715

x8



TE17BL

10

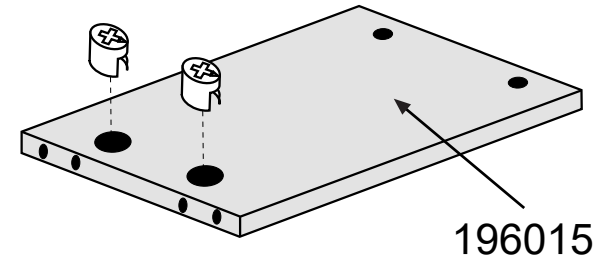

196015

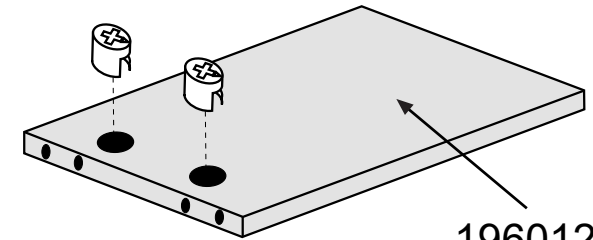

196012

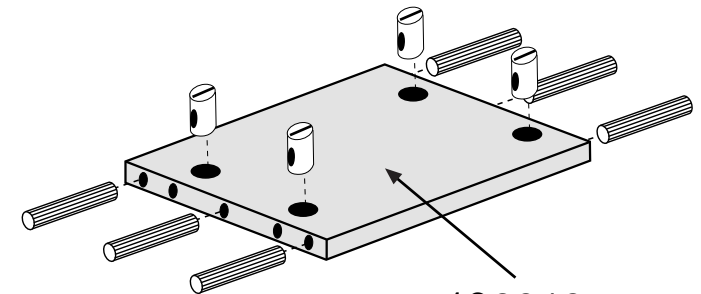
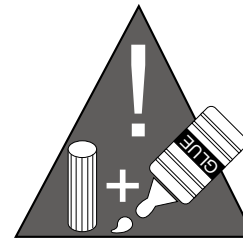

196013

cm 0 1 2 3 4 5 6

CL1060

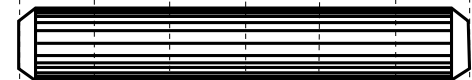

x6

TUEM61013

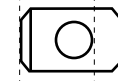

x4

EX16



x4

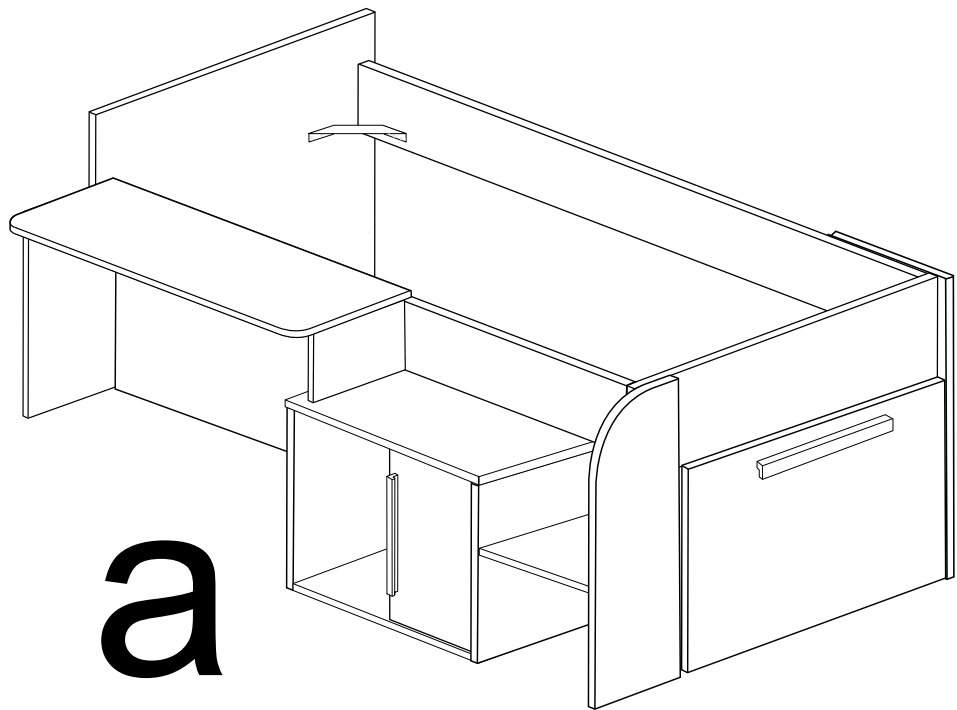

a

?

b

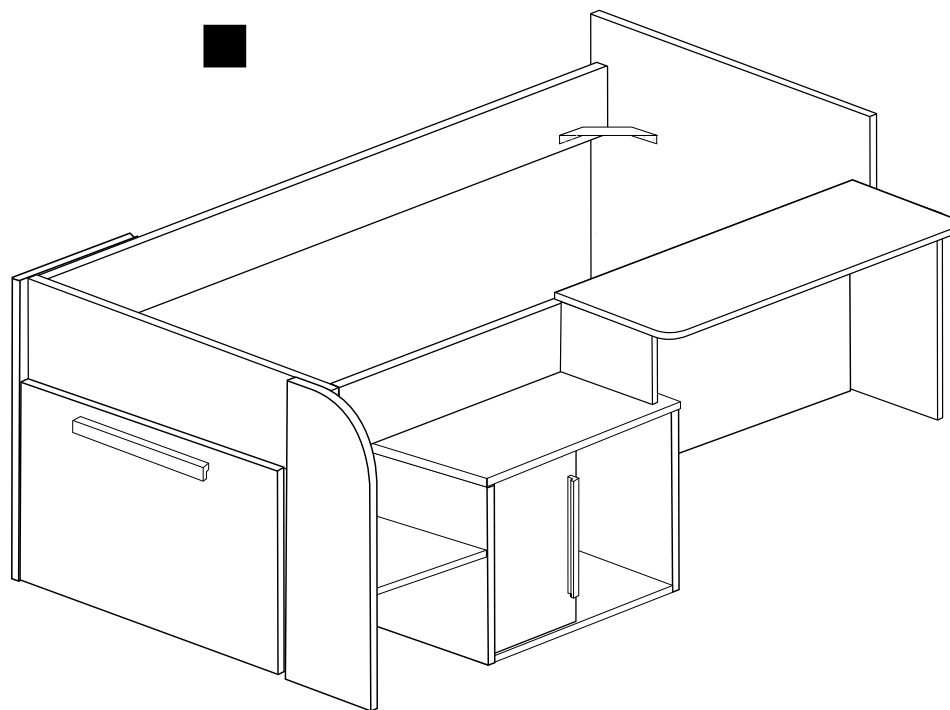

cm 0 1 2 3 4 5 6

TA550  x4

TV3135  x4

EX16  x2

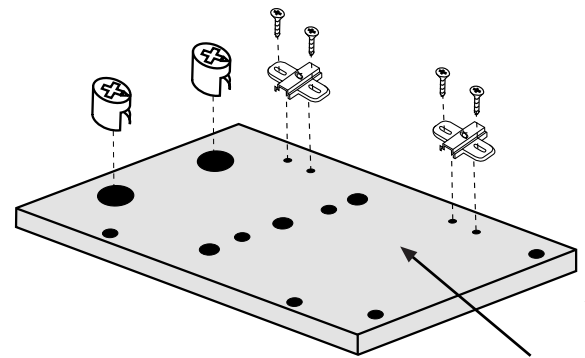

196009

11a

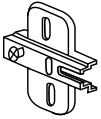
x2

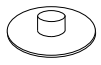
BA35S

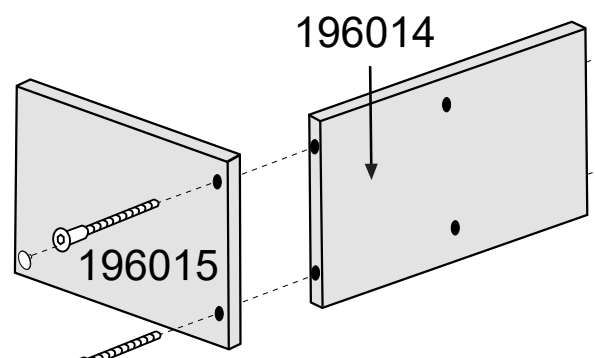
x4

TA3RK

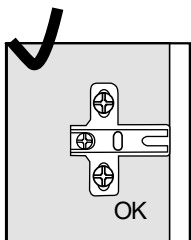
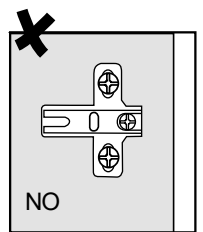

196015

196014



12a

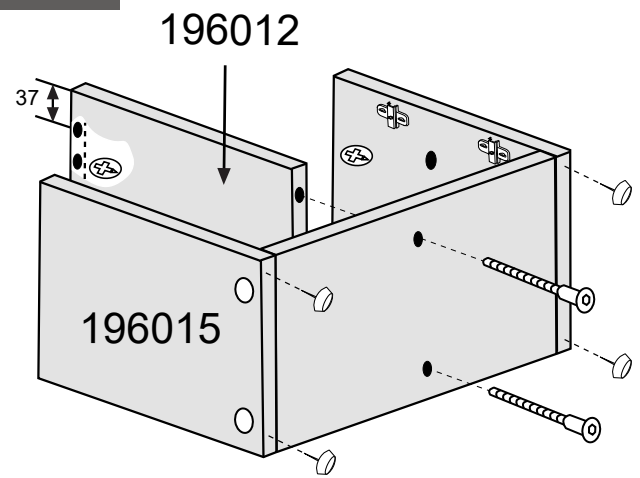

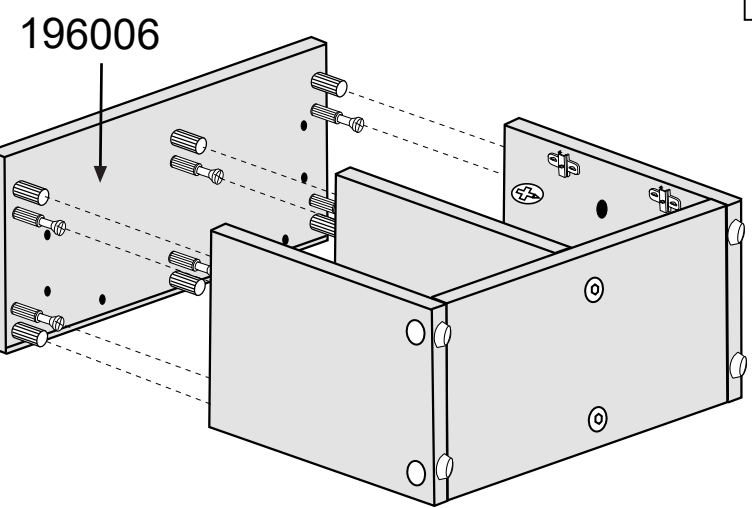

196012

196015

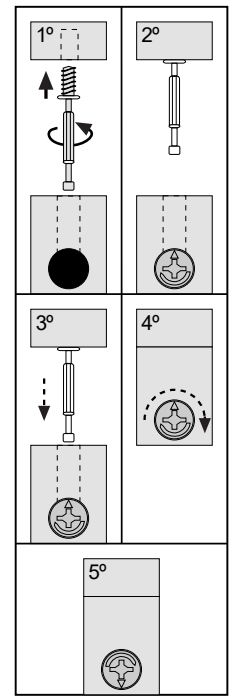

196006



x4

TSM

cm 0 1 2 3 4 5

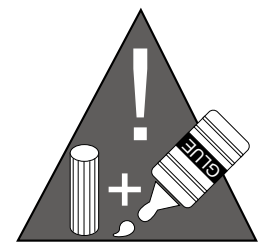
TA550  x2

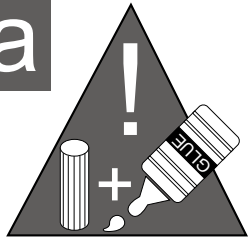

13a



x2	x3
TA3RK	T10RK

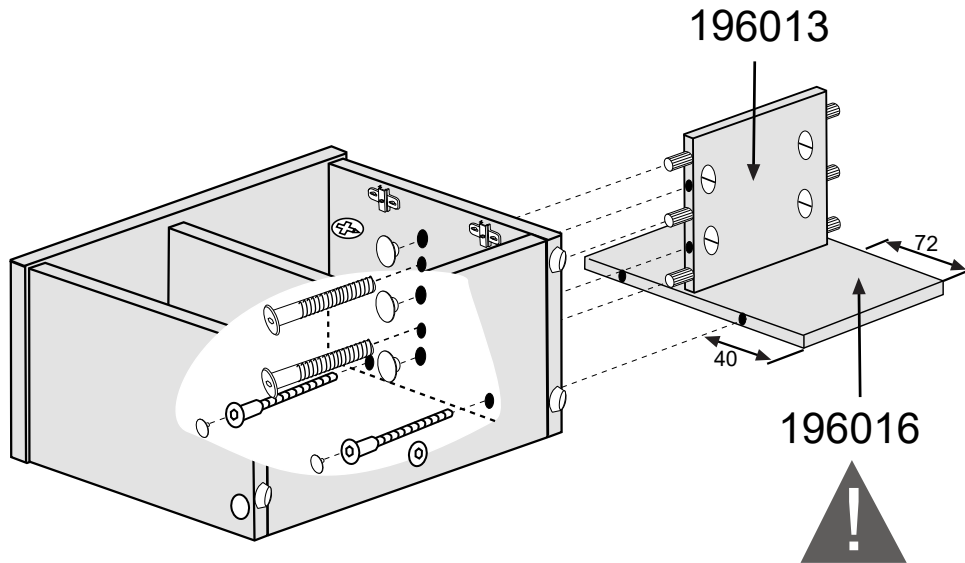

cm 0 1 2 3 4 5 6

TA550		x2
TM660A		x2

14a

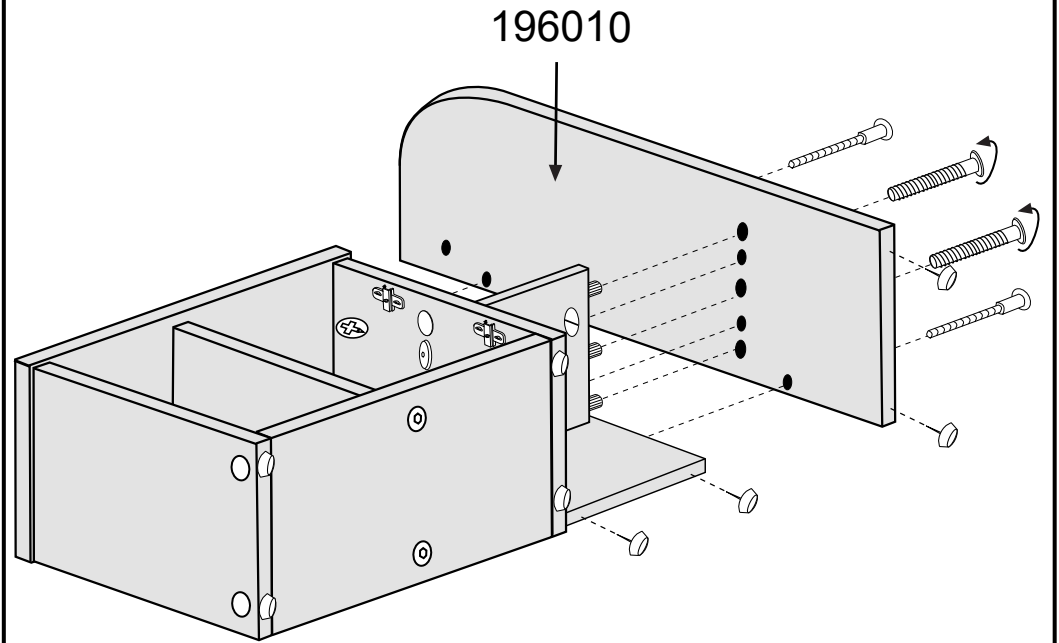
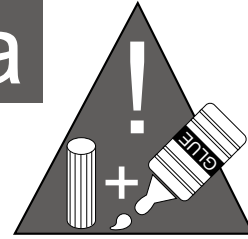

cm 0 1 2 3 4 5 6

TA760		x2
TM660A		x2

x4
TSM

15a

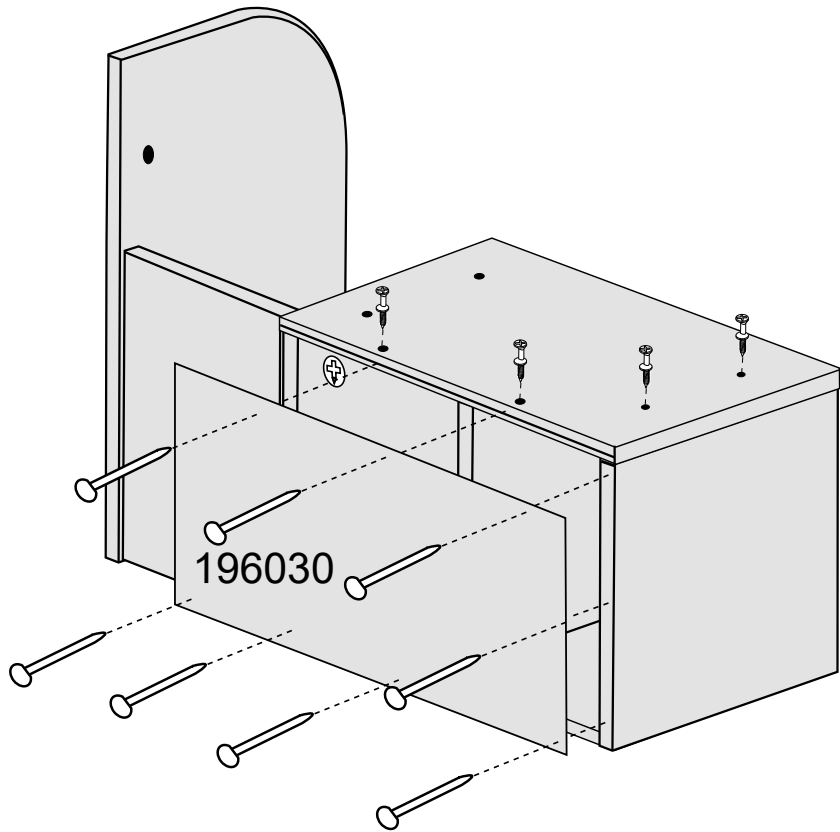

x30



P1030

cm 0 1 2 3

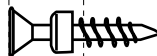

TCK0311 x4

16a

x1

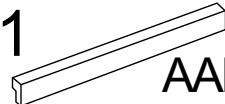

AAM220

x2



TCA4030

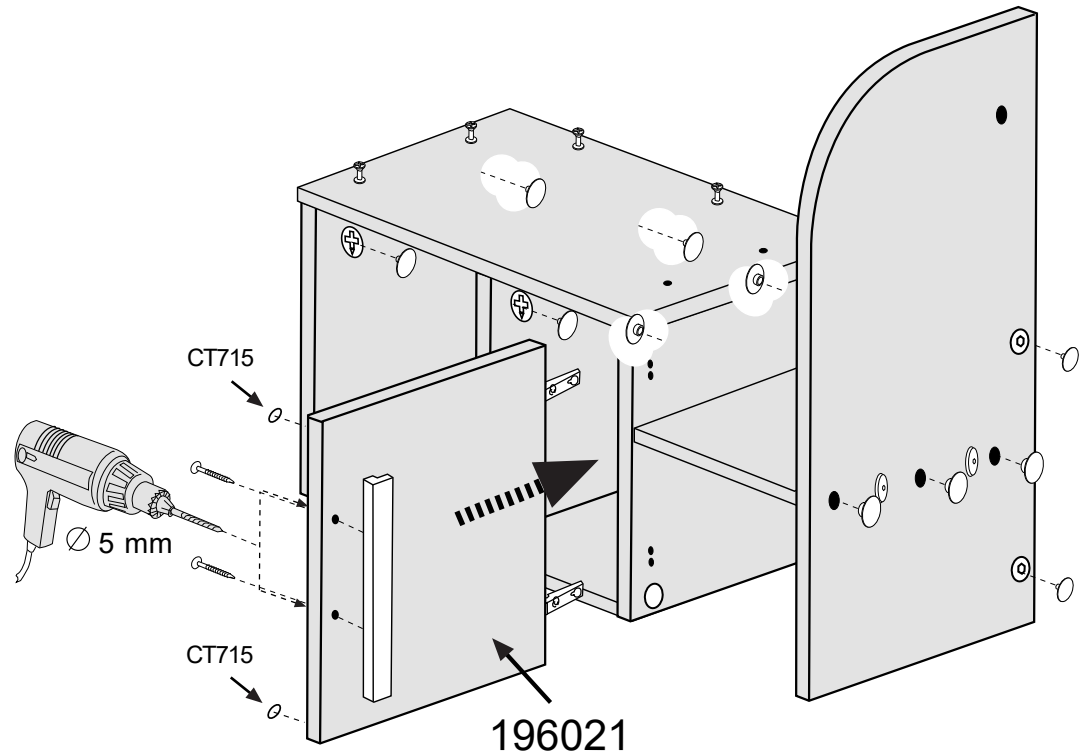

x1(2)

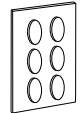

CT715

x3



T10RK

x2



TA4RK

x2



TE17BL

x4





TE17RK

17a

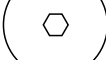

cm 0 1 2 3 4 5 6

TM660A   x1

TUEM61013   x4

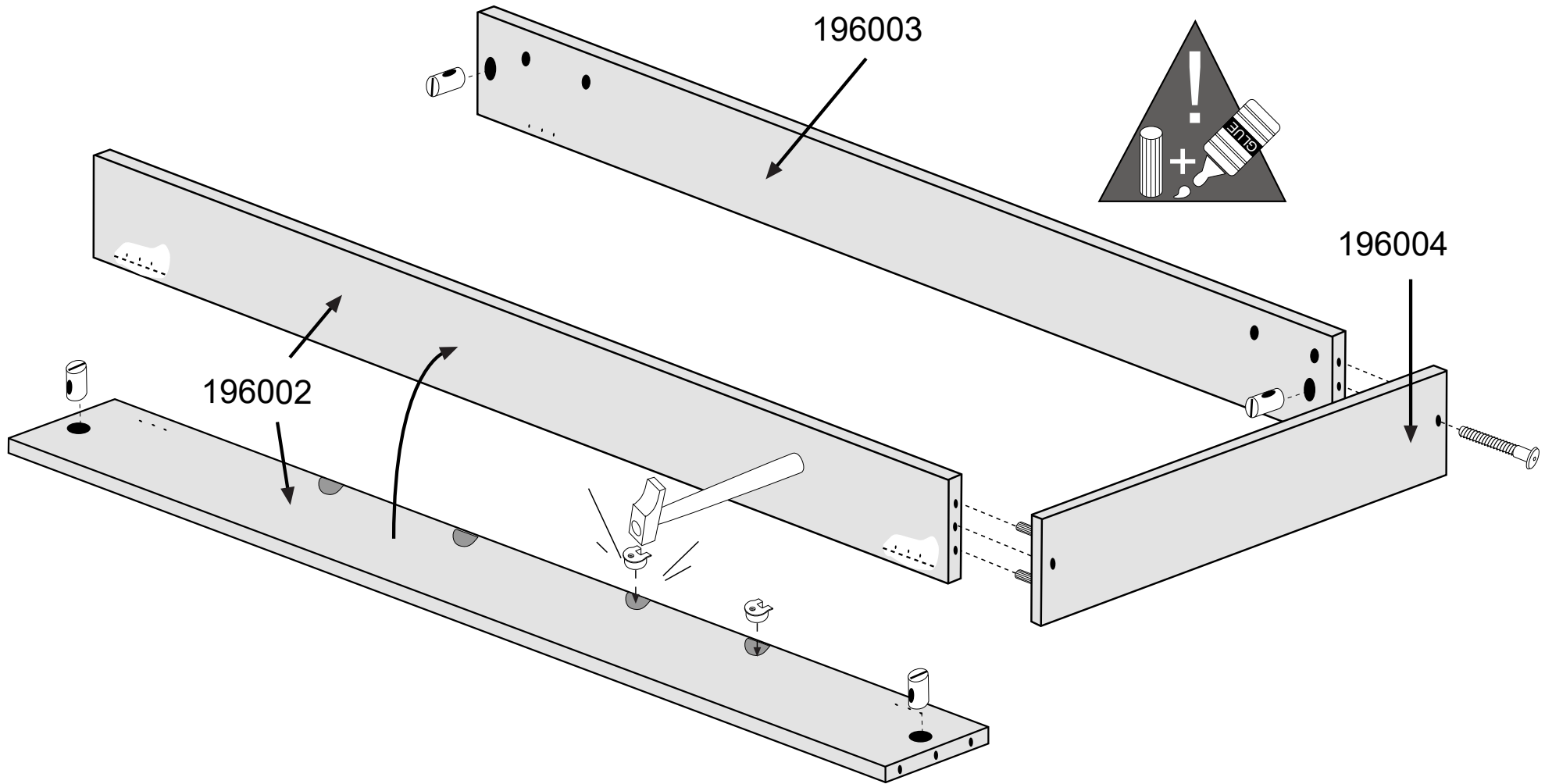

18a

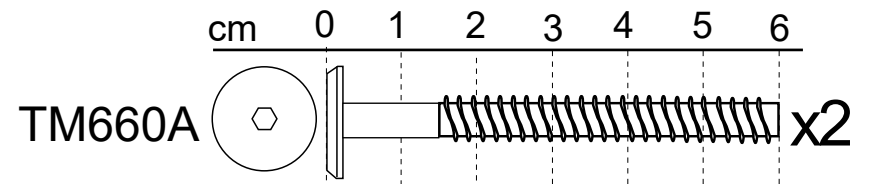
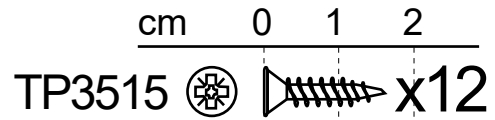
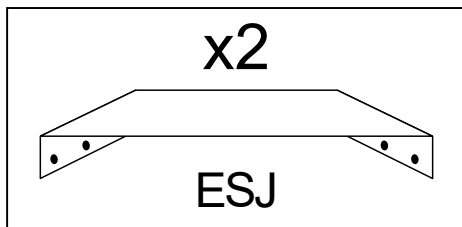
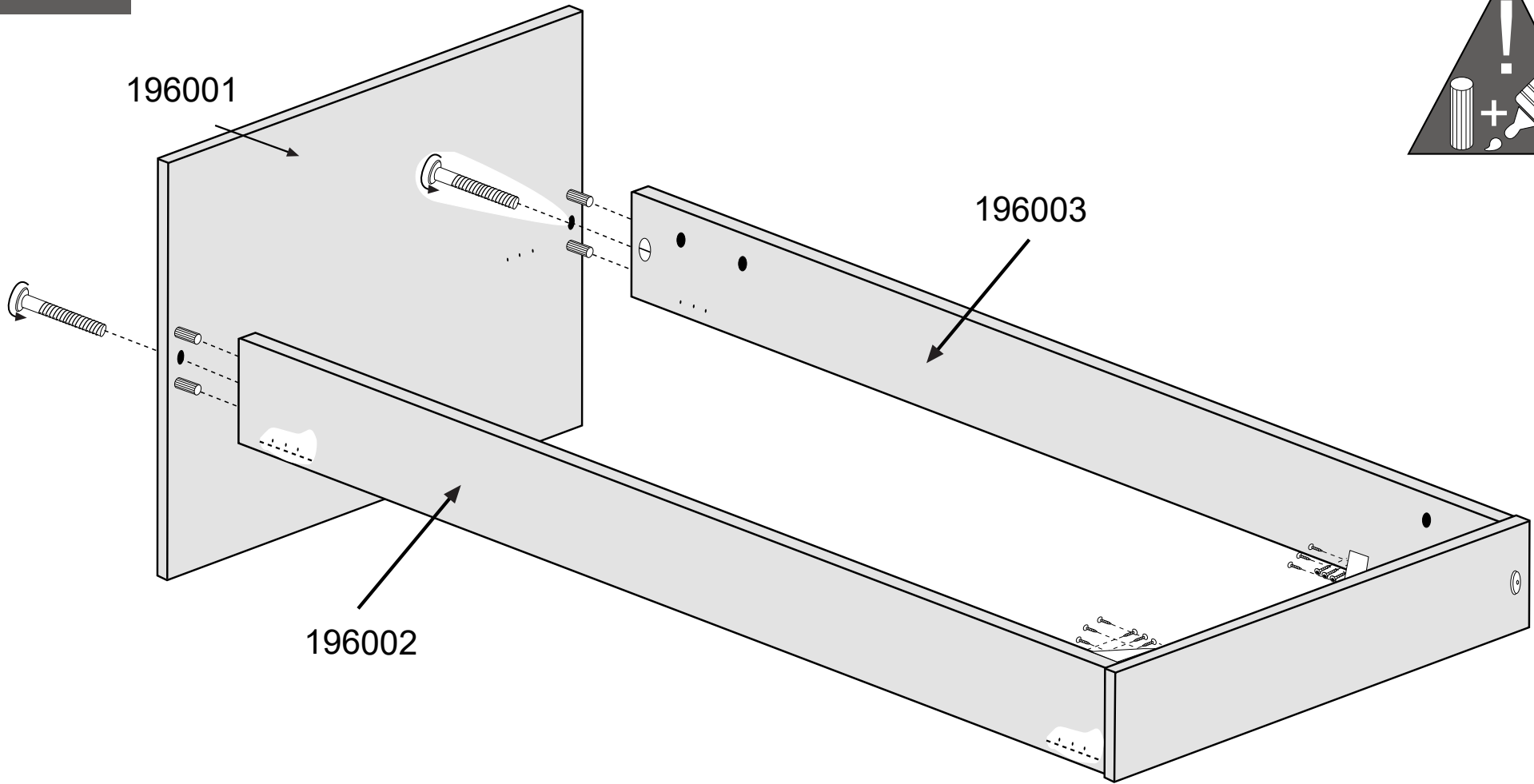
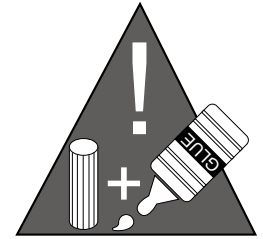

19a

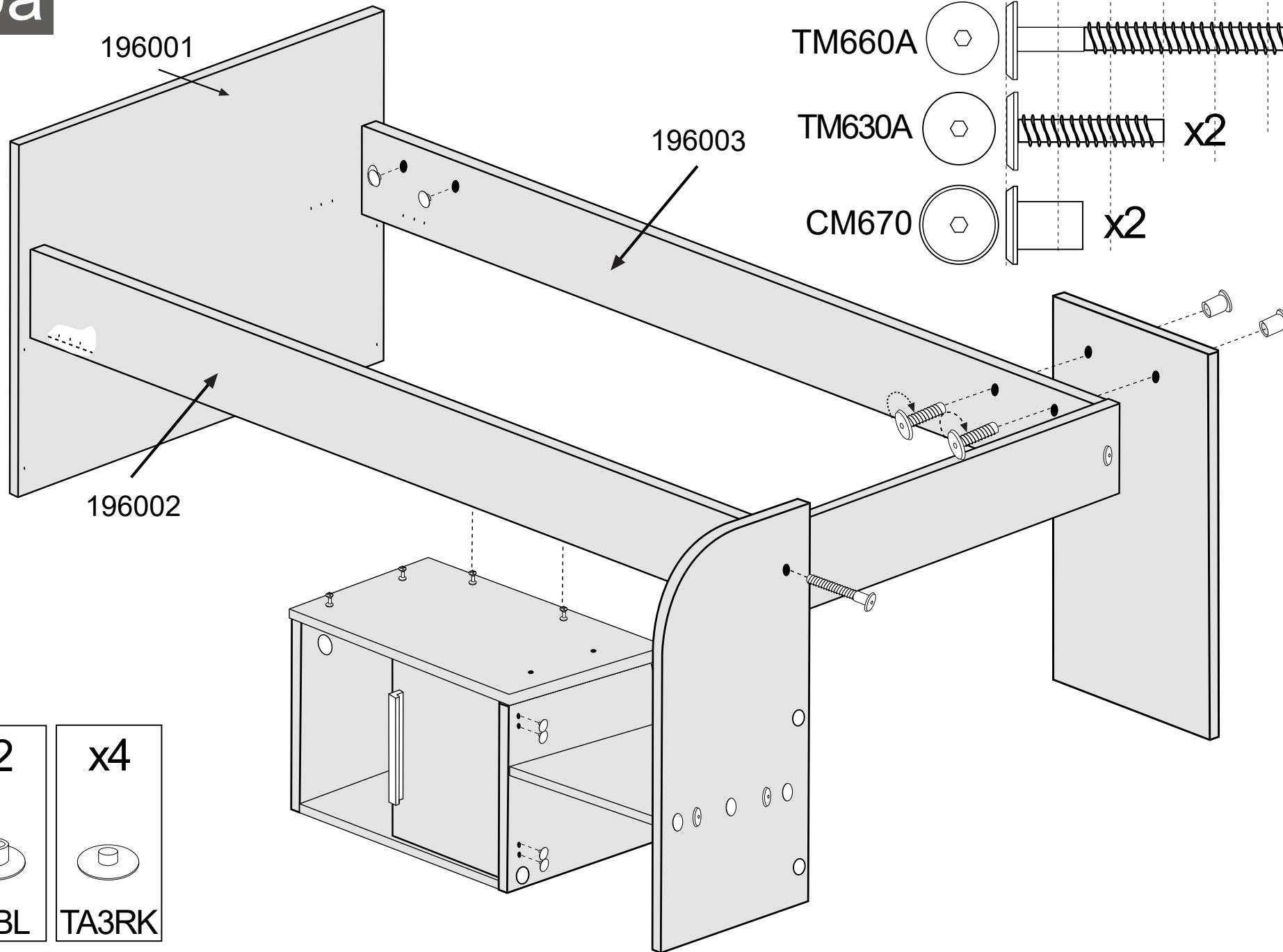

196001

196003

196002

cm 0 1 2 3 4 5 6

TM660A x1

TM630A x2

CM670 x2

x2

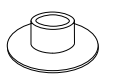

T8BL

x4

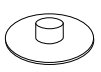

TA3RK

20a

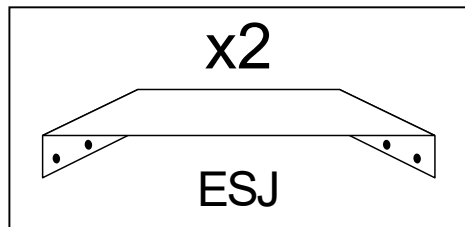
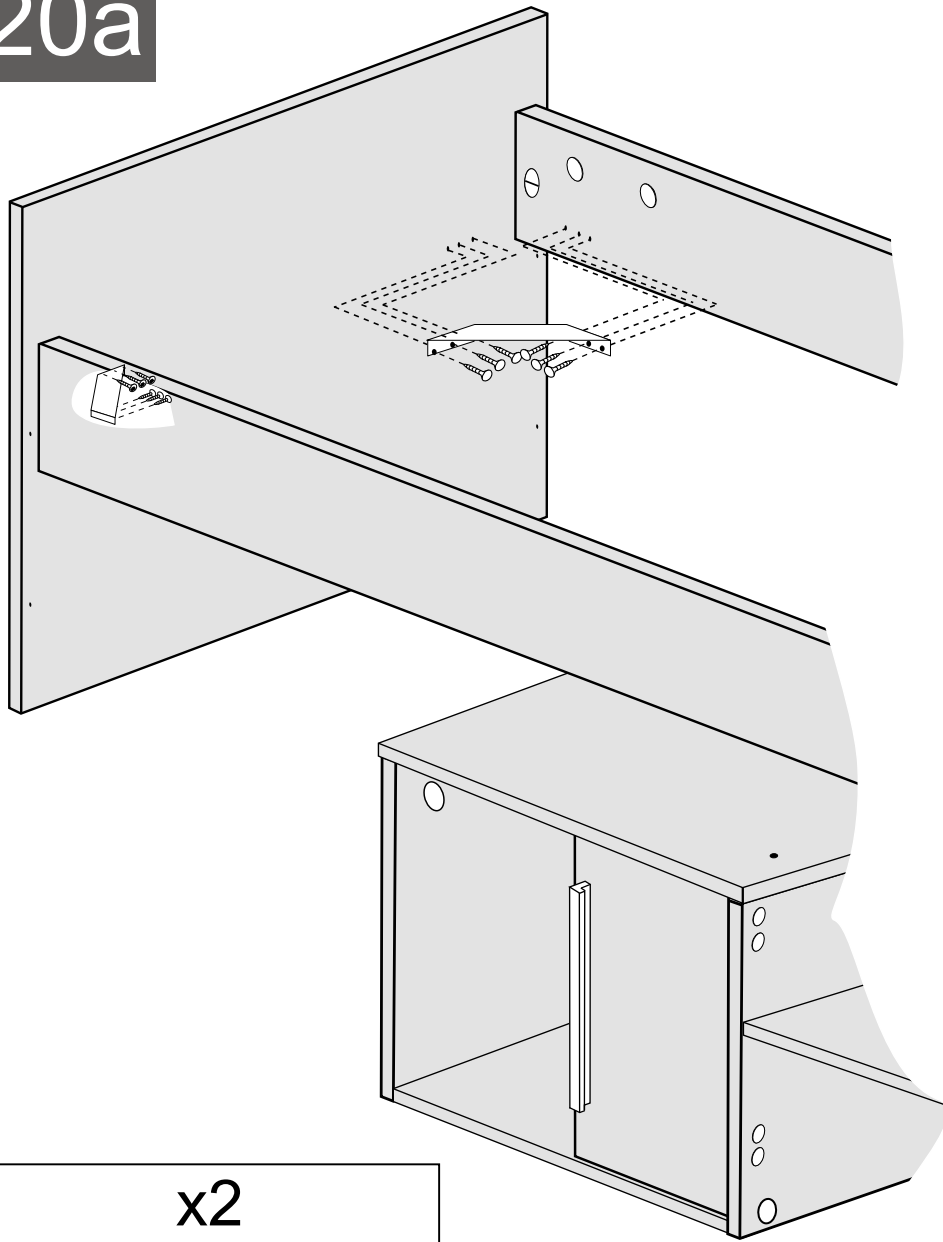

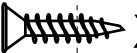
cm 0 1 2
 TP3515   x12

21a

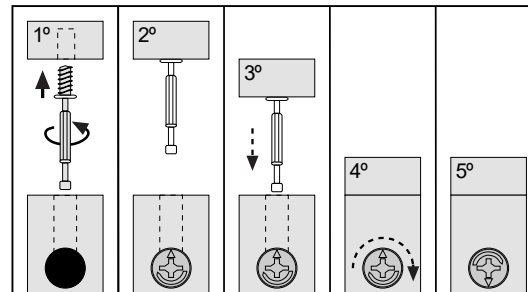
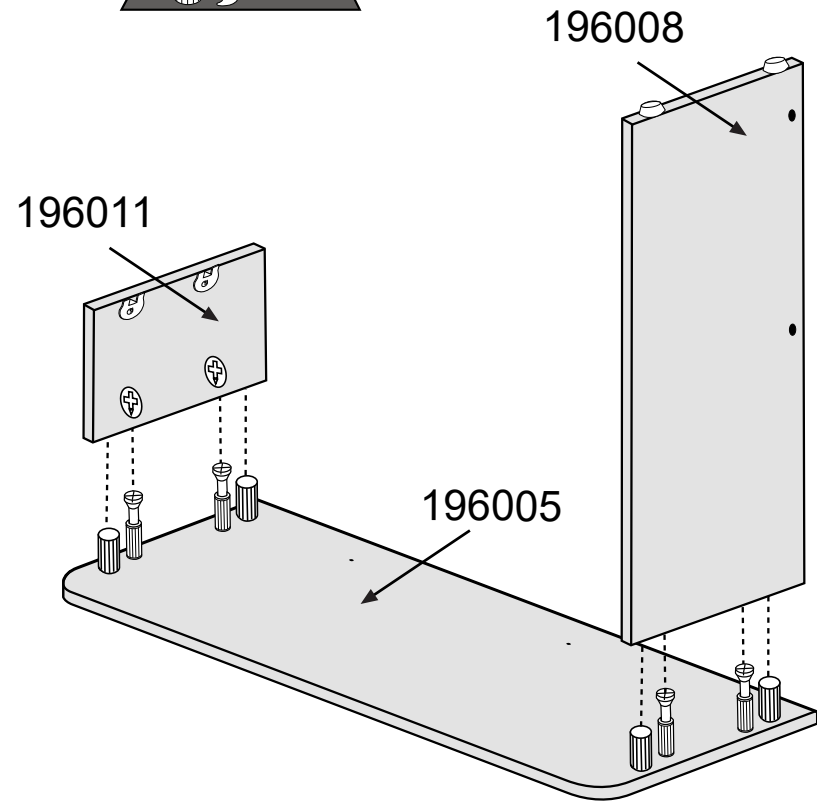
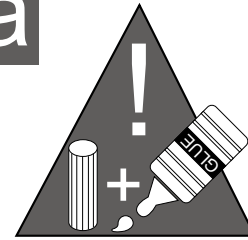

22a

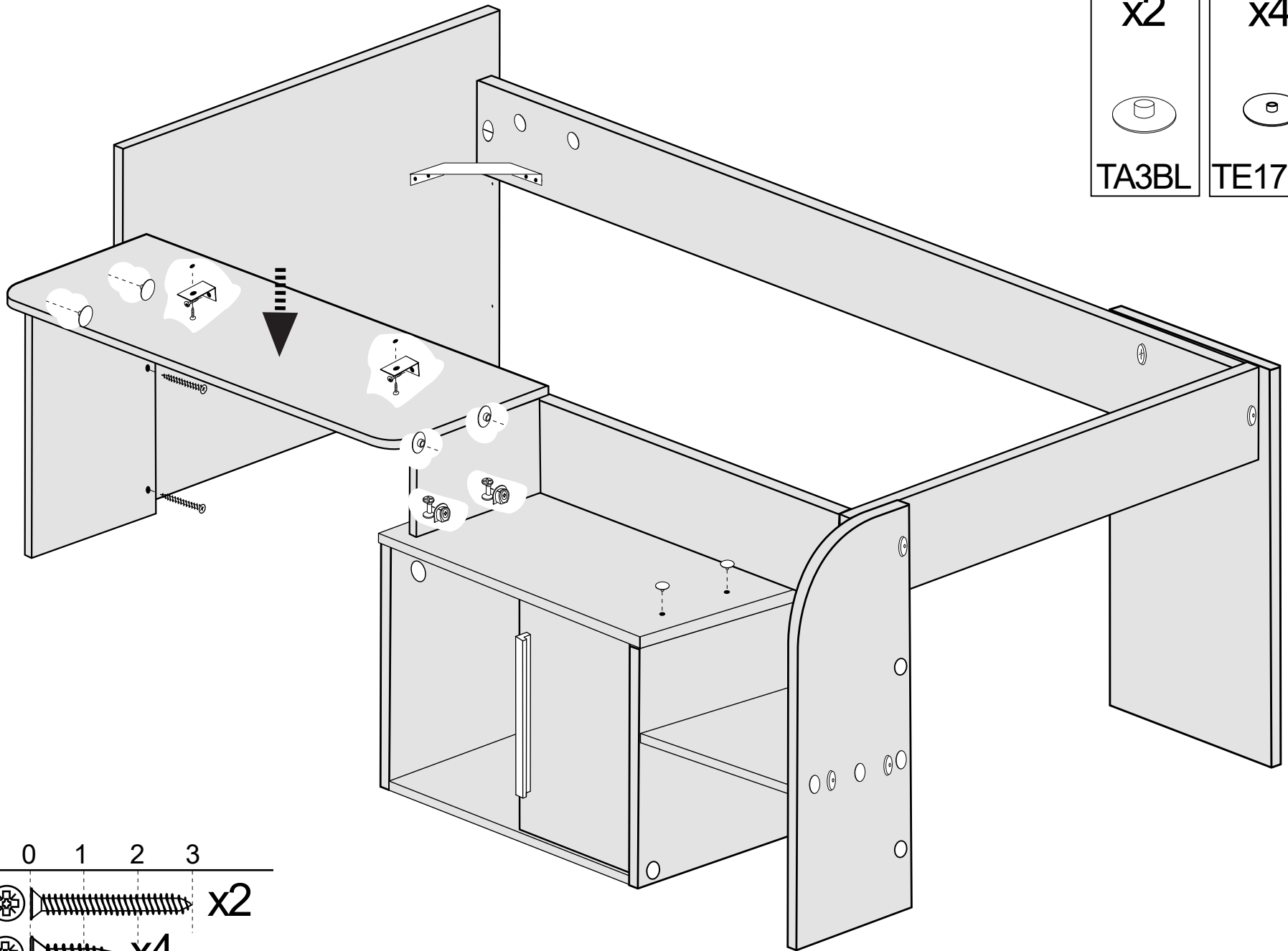

x2	x4
TA3BL	TE17RK

x2
E2137

cm 0 1 2 3

TP3530		x2
TP4016		x4

23a

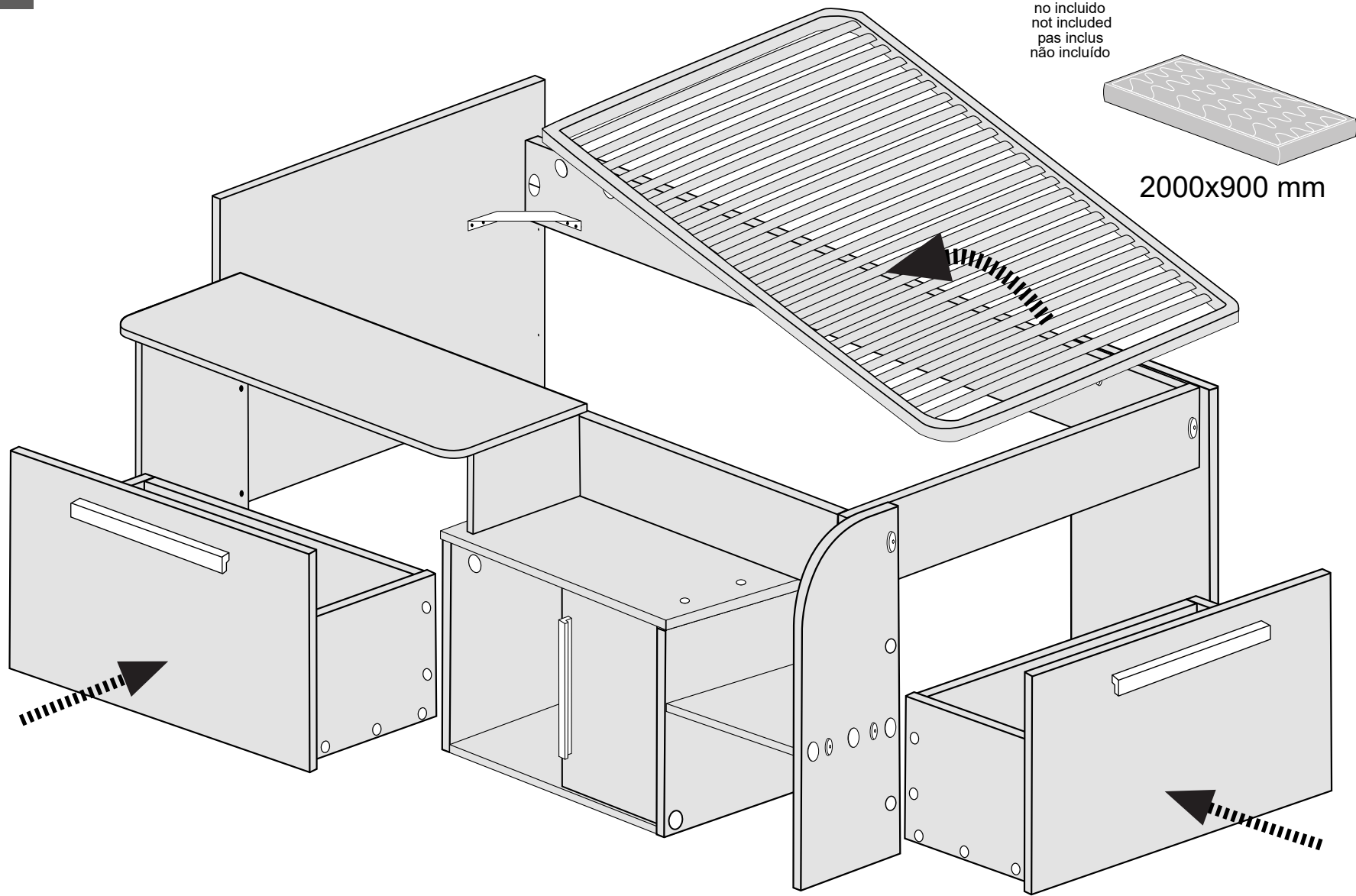

cm 0 1 2 3 4 5 6

TA550  x4

TV3135  x4

EX16  x2

11b

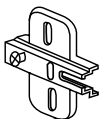
x2

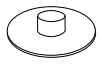
BA35S

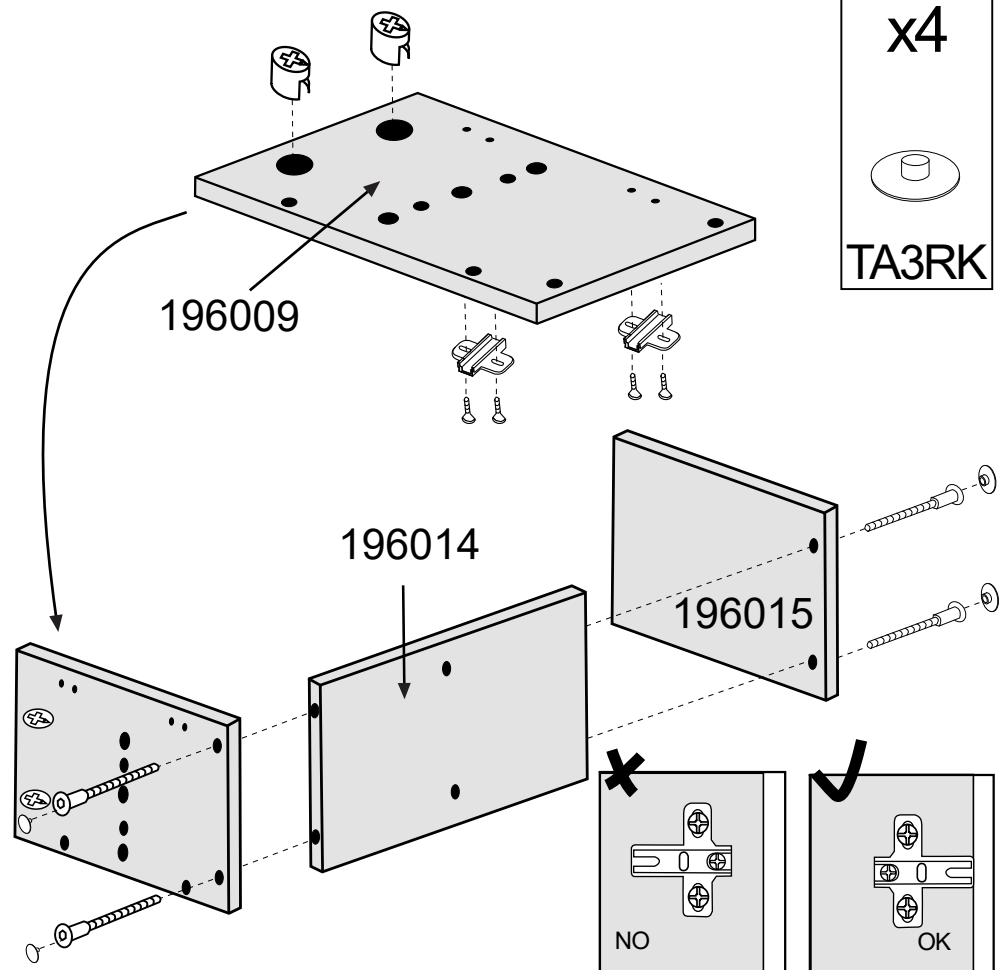
x4

TA3RK

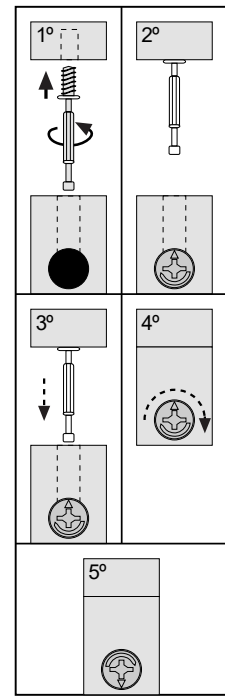
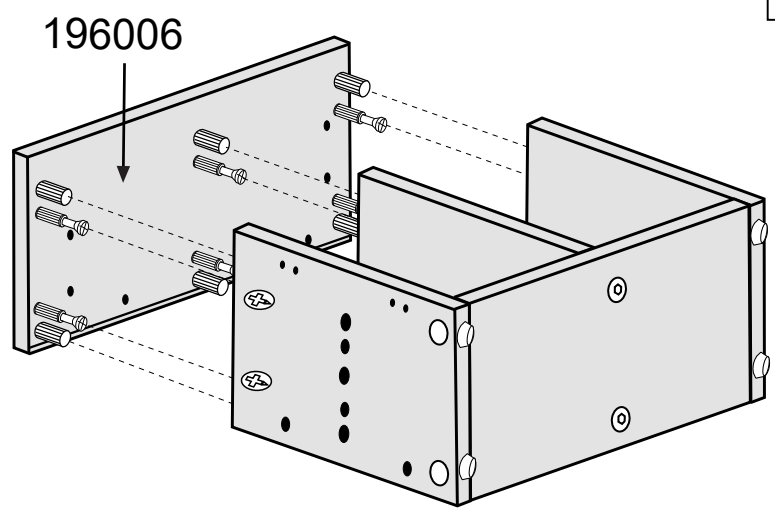
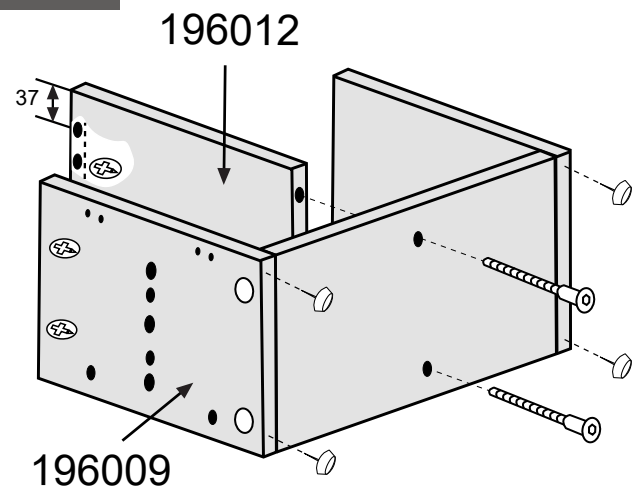

12b



x4

TSM

cm 0 1 2 3 4 5

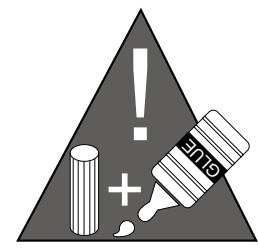
TA550  x2

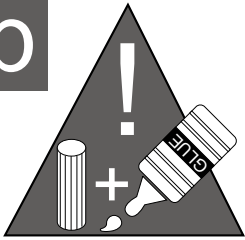

13b



x2	x3
TA3RK	T10RK

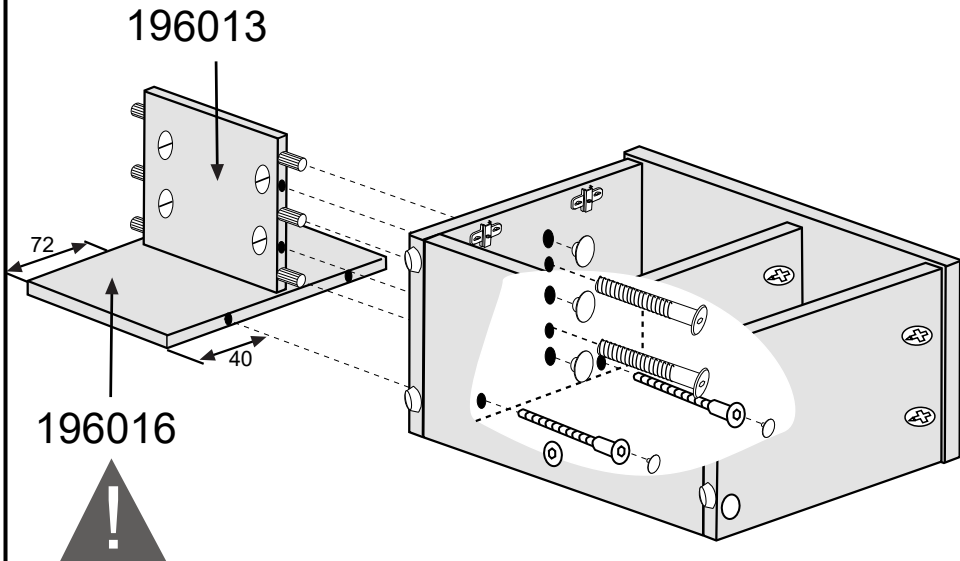

cm 0 1 2 3 4 5 6

TA550 x2

TM660A x2

14b

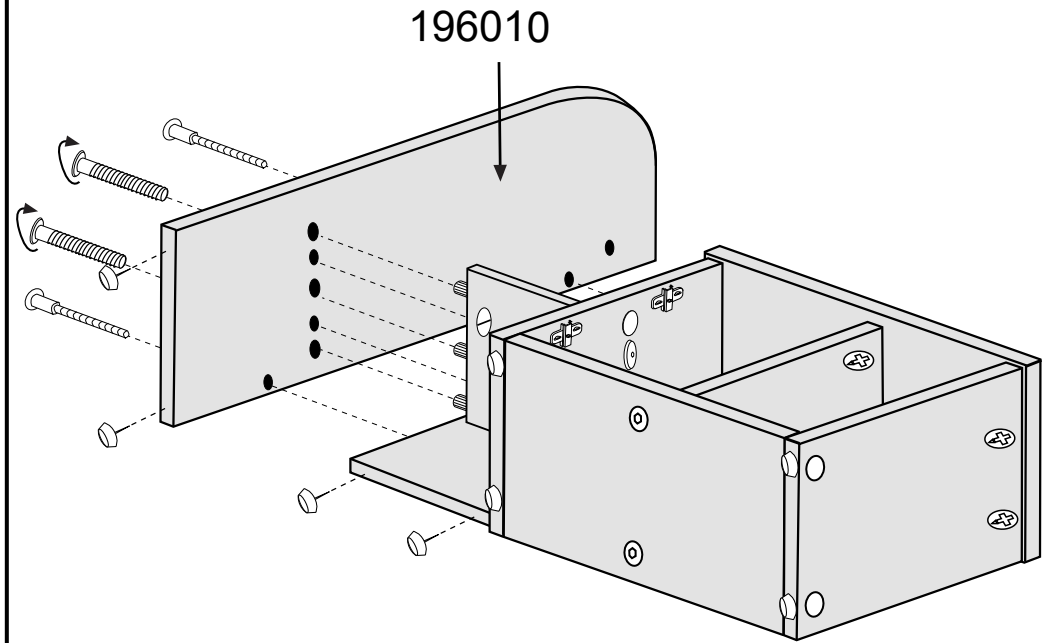
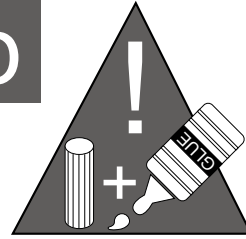

cm 0 1 2 3 4 5 6

TA760 x2

TM660A x2

x4
TSM

15b

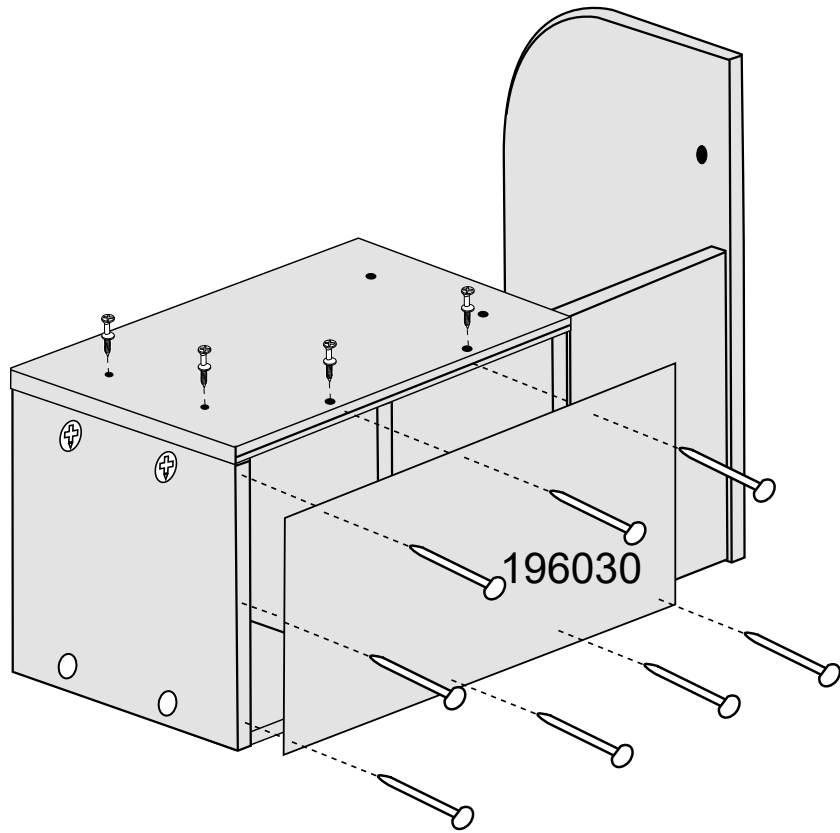

x30

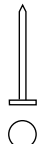

P1030

cm 0 1 2 3

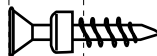

TCK0311 x4

16b

x1

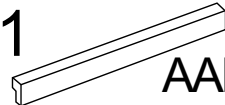

AAM220

x2



TCA4030

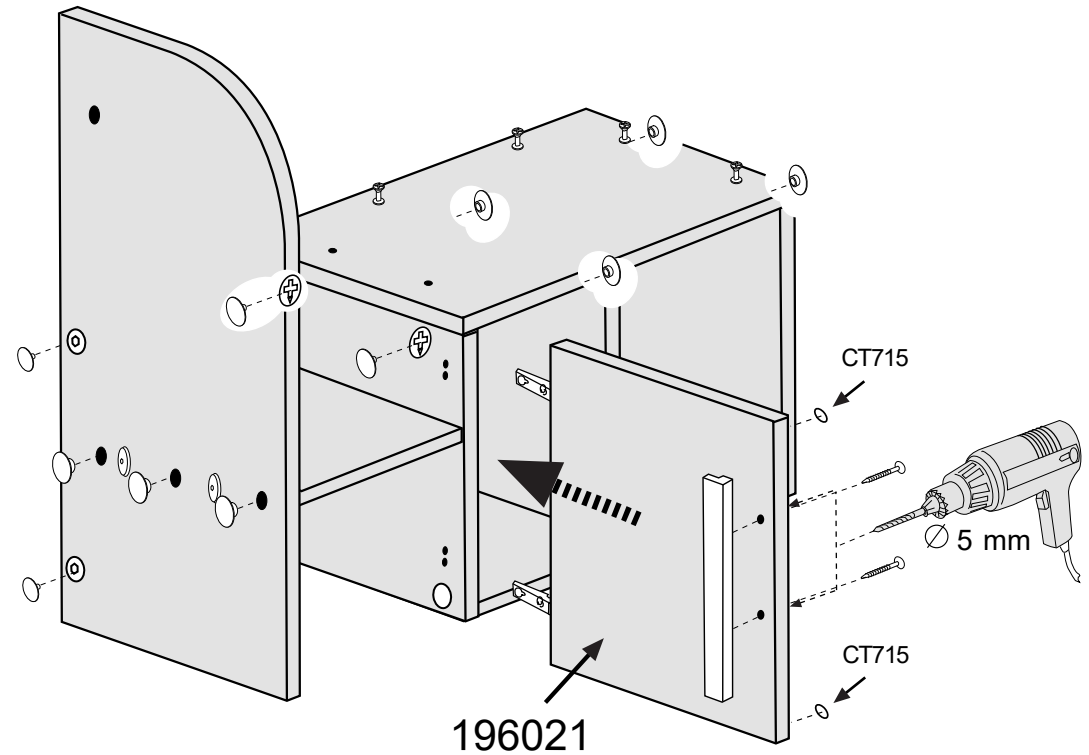

x1(2)

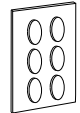

CT715

x3



T10RK

x2



TA4RK

x2



TE17BL

x4



TE17RK

17b

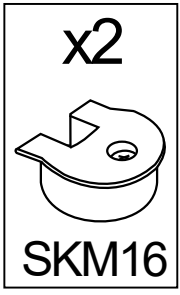

cm 0 1 2 3 4 5 6

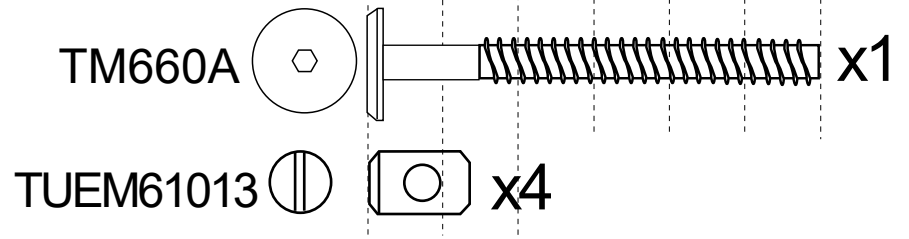

196003

196004

196002

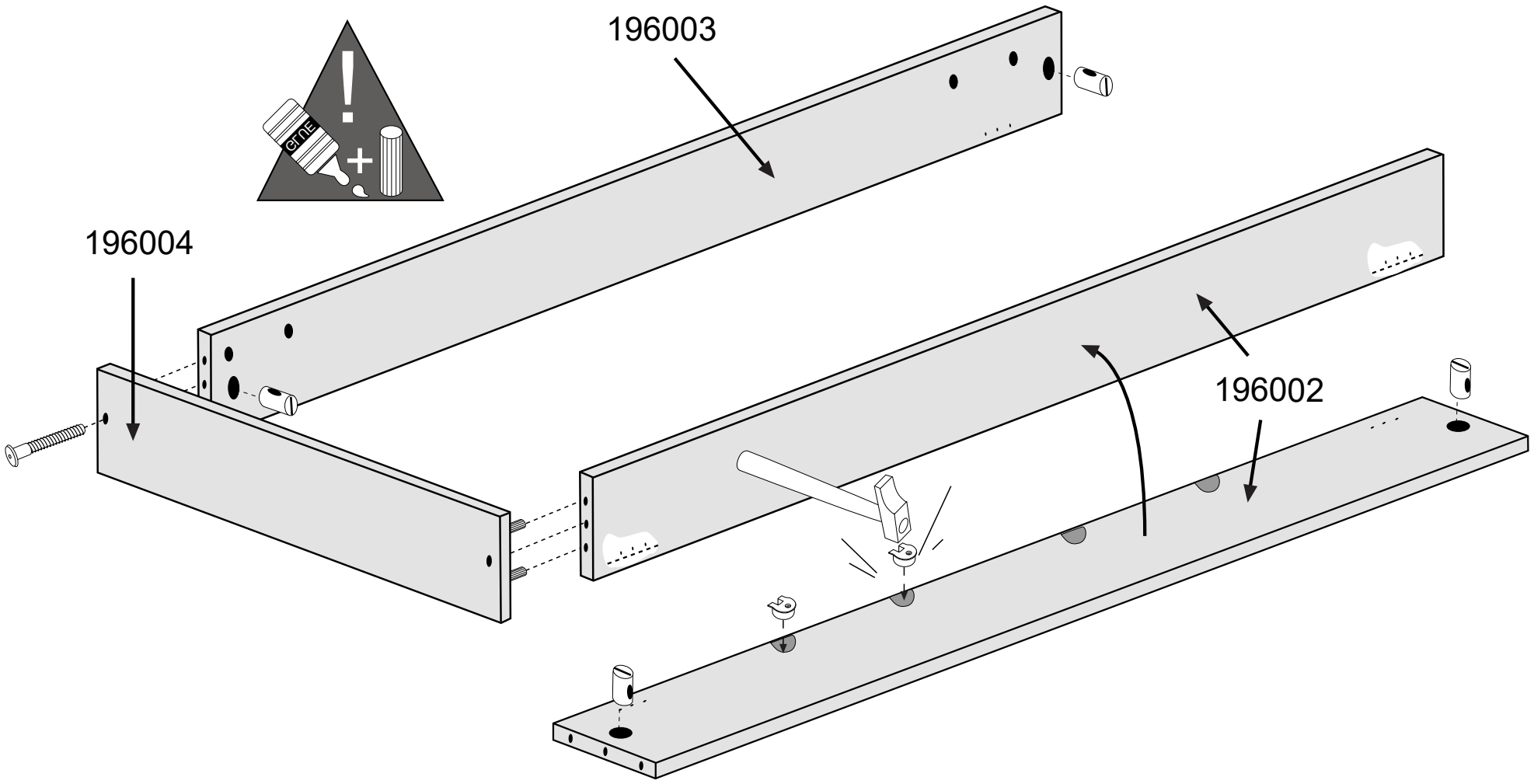

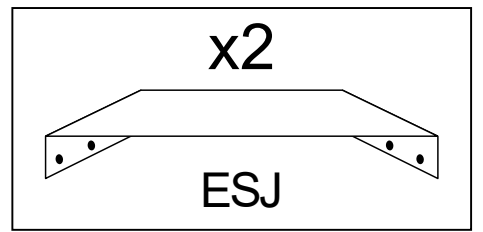
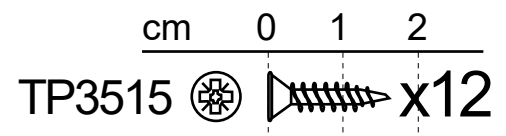
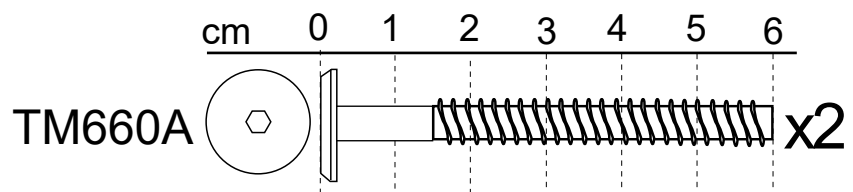
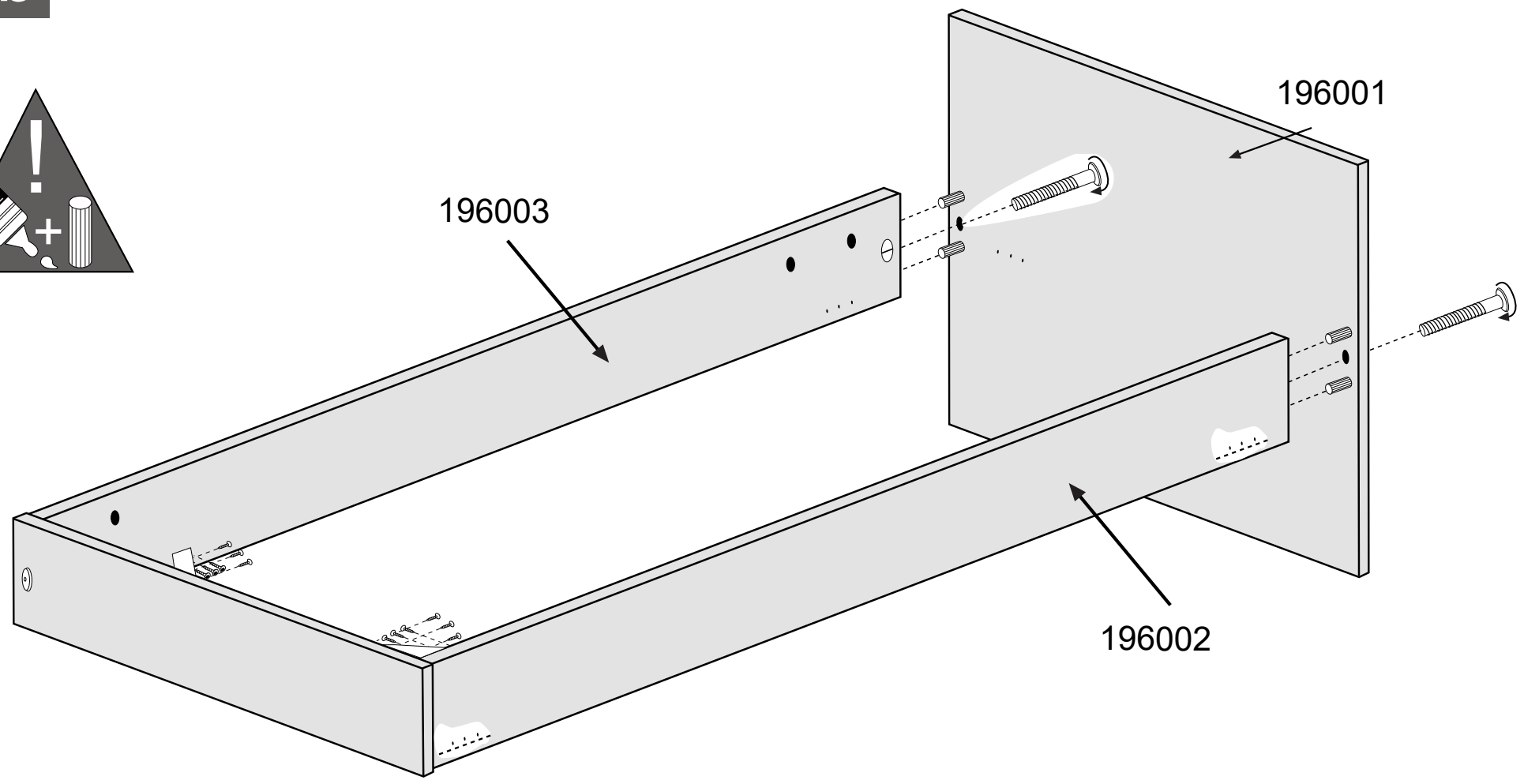

18b

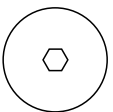
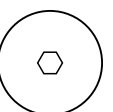
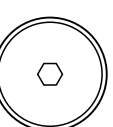

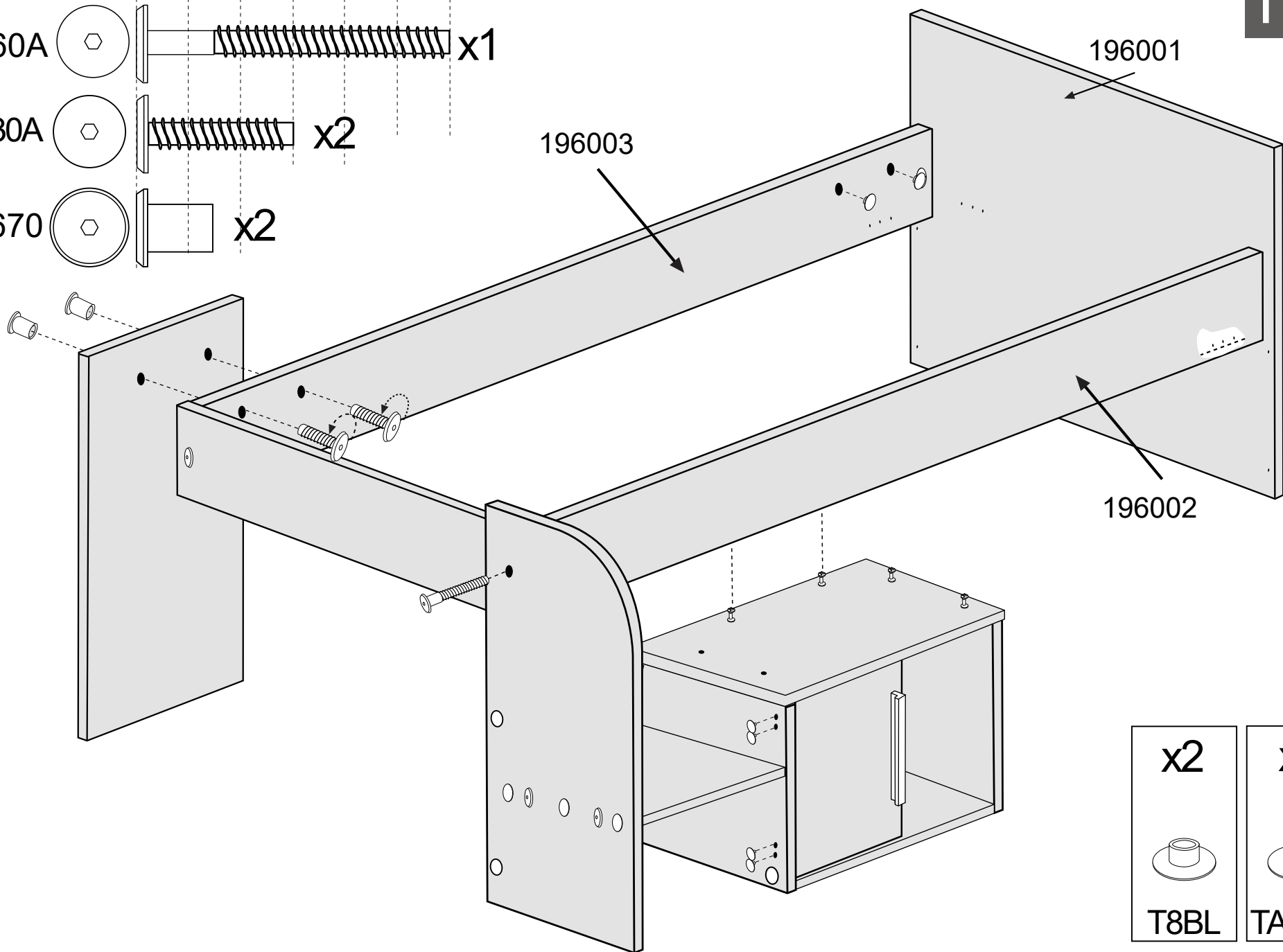
- cm 0 1 2 3 4 5 6
- TM660A  x1
 - TM630A  x2
 - CM670  x2

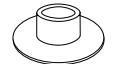

- | | |
|---|---|
| x2 | x4 |
|  |  |
| T8BL | TA3RK |

20b

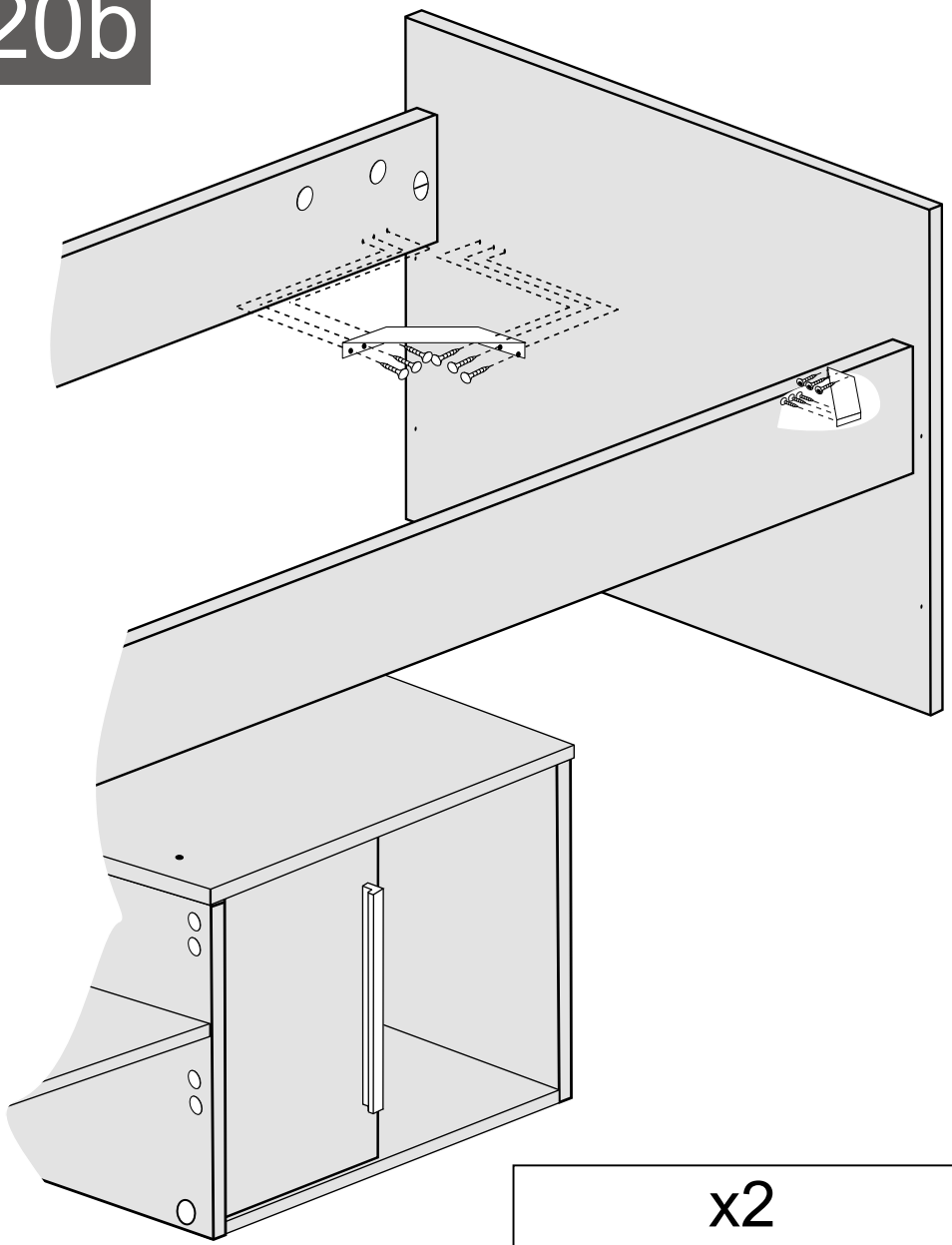

cm 0 1 2

TP3515  x12

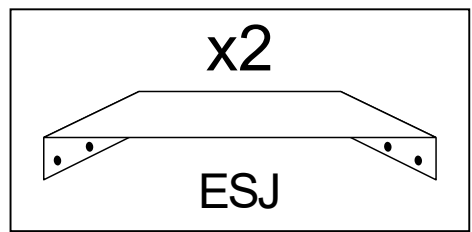

21b

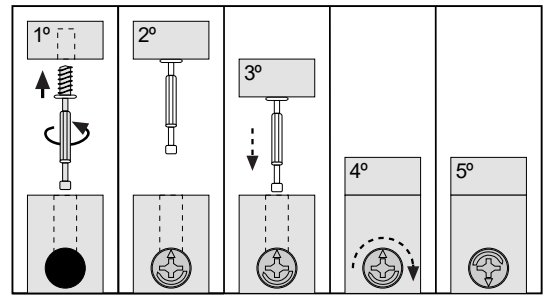
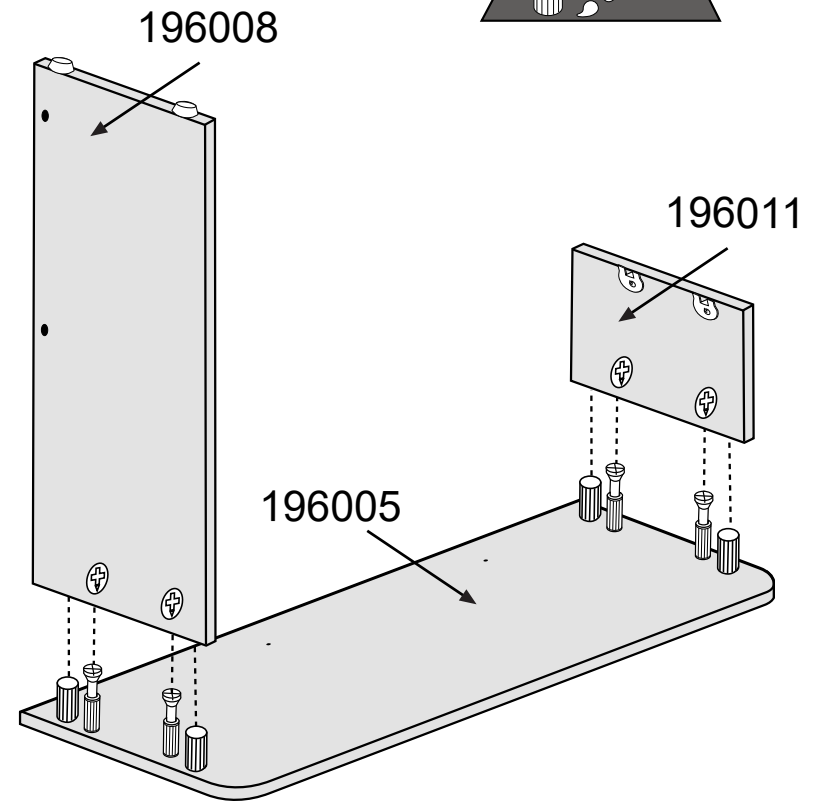
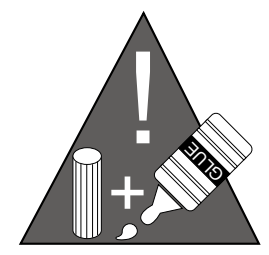

x2

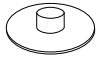

TA3BL

x4



TE17RK

22b

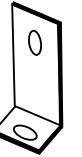

x2

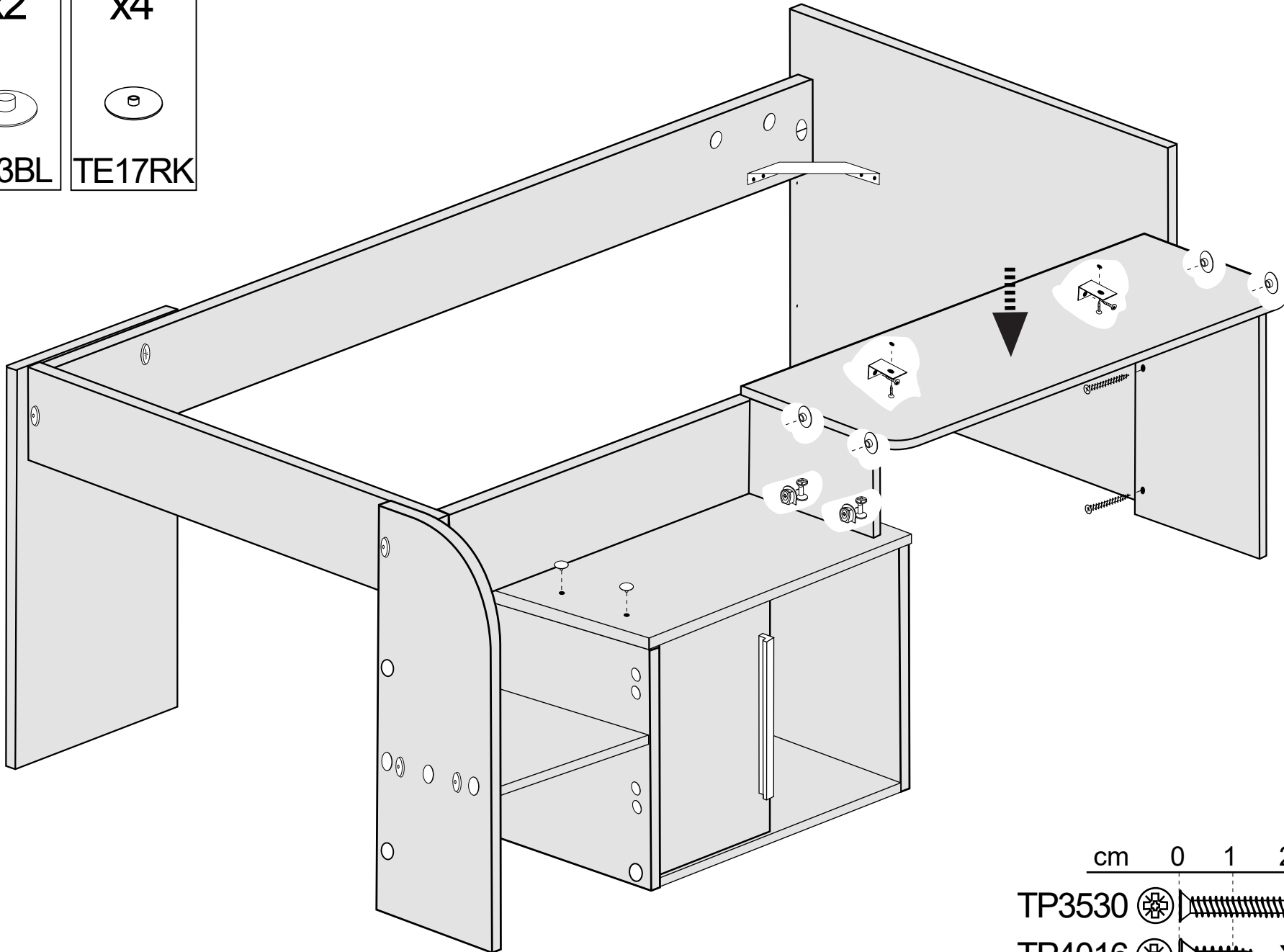

E2137



cm 0 1 2 3

TP3530   x2

TP4016   x4

no incluido
not included
pas inclus
não incluido

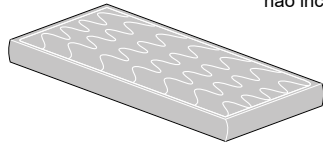

2000x900 mm

