

PORTAIL COULISSANT EN ALUMINIUM  
ALUMINUM SLIDING GATE  
SCHIEBETOR AUS ALUMINIUM  
PUERTA CORREDERA DE ALUMINIO  
CANCELLO SCORREVOLE IN ALLUMINIO  
ALUMINIUM SCHUIFPOORT  
PORTÃO DESLIZANTE DE ALUMÍNIO  
ALUMINIOWA BRAMA PRZESUWNA

## TARNOS/TARNOS II

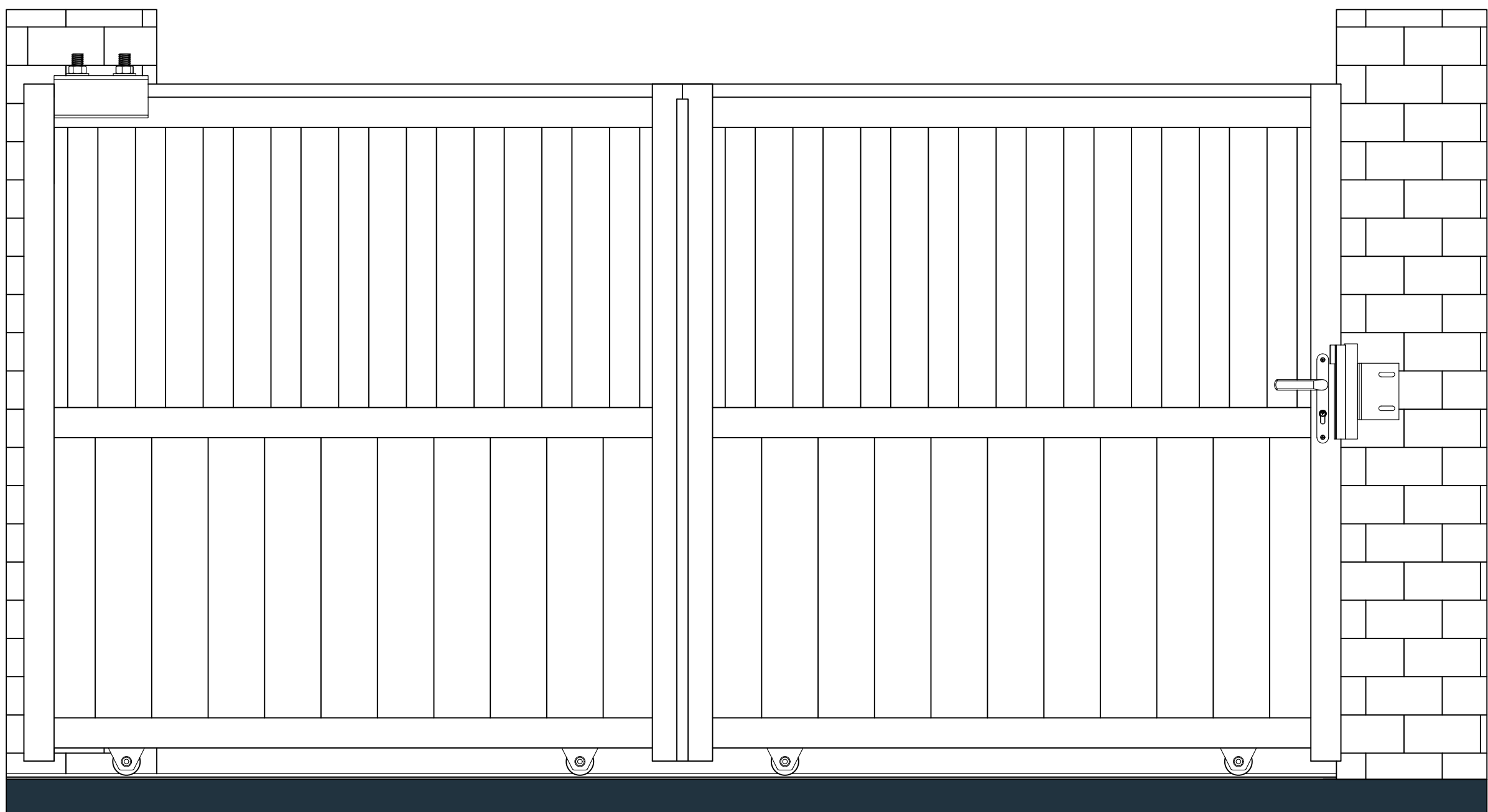

UV08-2D/UV08-5D/UV08-6D

**FR**

*Inspectez votre porte, en particulier la pièce d'usure comme le rouleau supérieur, la serrure, le verrou, la poulie, le butoir de porte tous les 6 mois, si le produit ou le composant est endommagé, veuillez cesser d'utiliser le produit immédiatement et contacter notre service clientèle pour obtenir une aide professionnelle. le produit et la maintenance.*

**EN**

*Inspect your door especially the wearing part like top roller, lock, lock keeper, pulley, gate stopper for every 6 months, if the product or component is damaged, please stop using the product immediately and contact our customer service to get a professional help about the product and the maintenance.*

**DE**

*Überprüfen Sie Ihre Tür, insbesondere das Verschleißteil wie Oberrolle, Schloss, Schlosshalter, Riemenscheibe, Torstopper, alle 6 Monate. Wenn das Produkt oder die Komponente beschädigt ist, stellen Sie die Verwendung des Produkts sofort ein und wenden Sie sich an unseren Kundendienst, um professionelle Hilfe zu erhalten das Produkt und die Wartung.*

**ES**

*Inspeccione su puerta, especialmente la pieza de desgaste, como el rodillo superior, la cerradura, el cerrojo, la polea, el tope de la puerta cada 6 meses, si el producto o componente está dañado, deje de usar el producto de inmediato y comuníquese con nuestro servicio de atención al cliente para obtener ayuda profesional. el producto y el mantenimiento.*

**IT**

*Ispeziona la tua porta in particolare la parte soggetta a usura come rullo superiore, serratura, fermo serratura, puleggia, fermo del cancello per ogni 6 mesi, se il prodotto o il componente è danneggiato, interrompi immediatamente l'uso del prodotto e contatta il nostro servizio clienti per ottenere un aiuto professionale in merito il prodotto e la manutenzione.*

**NL**



*Inspecteer uw deur, met name het slijtende onderdeel zoals bovenrol, slot, slothouder, katrol, poortstopper voor elke 6 maanden. Als het product of onderdeel beschadigd is, stop dan onmiddellijk met het gebruik van het product en neem contact op met onze klantenservice voor professionele hulp over het product en het onderhoud.*

**PT**

*Inspecione especialmente a parte de desgaste como rolo superior, fechadura, fecho, roldana, rolha de portão durante cada 6 meses, se o produto ou componente estiver danificado, pare de usar o produto imediatamente e contacte o nosso serviço de apoio ao cliente para obter uma ajuda profissional sobre o produto e a manutenção.*

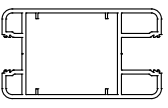
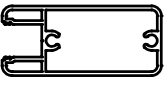
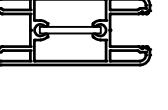
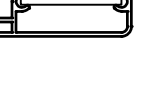
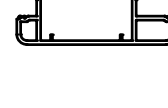
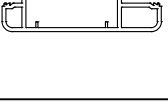
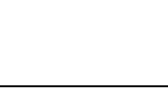
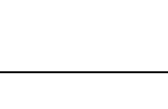
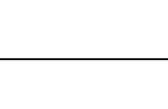
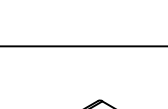
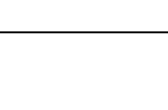
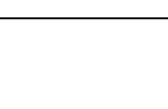
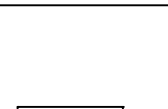
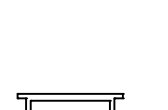
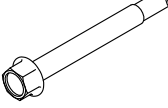

**PL**

*Sprawdzaj drzwi, zwłaszcza część zużywającą się, taką jak górna rolka, zamek, uchwyt na zamek, koło pasowe, korek bramy co 6 miesięcy, jeśli produkt lub komponent jest uszkodzony, natychmiast przestań używać produktu i skontaktuj się z naszym działem obsługi klienta, aby uzyskać profesjonalną pomoc dotyczącą produktu i konserwacji.*

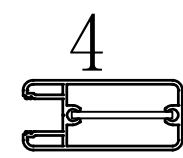
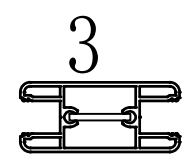
| BOX 1/4 |   |           |           |           |
|---------|---|-----------|-----------|-----------|
| NO.     | Section   | UV08-2D   | UV08-5D   | UV08-6D   |
|         |   | QTY (pcs) | QTY (pcs) | QTY (pcs) |
| 1       |                | 1         | 1         | 1         |
| 2       |                | 2         | 2         | 2         |
| 3       |                | 2         | 2         | 2         |
| 4       |                | 2         | 2         | 2         |
| 10      |              | 2         | 2         | 2         |
| 19      |              | 1         | 1         | 1         |
| 5       |              | 4         | 4         | 4         |
| 8       |              | 8         | 8         | 8         |
| 9       |              | 24+2      | 28+2      | 36+2      |
| 11      |              | 4         | 4         | 4         |
| 12      |              | 4         | 4         | 4         |
| 13      |              | 4         | 4         | 4         |
| 14      |              | 1         | 1         | 1         |
| 15      |              | 1         | 1         | 1         |
| 16      |              | 2         | 2         | 2         |
| 17      | <br>M6. 3*75 | 24        | 24        | 24        |



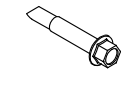
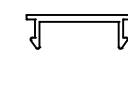



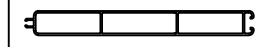
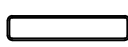



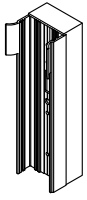
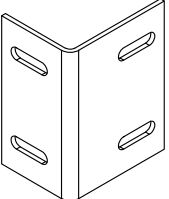
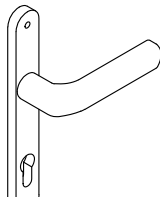
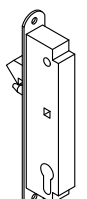
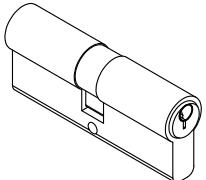
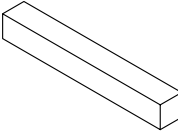
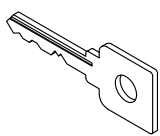
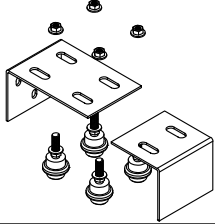
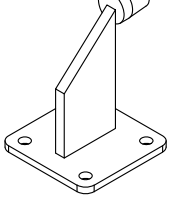
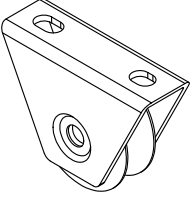
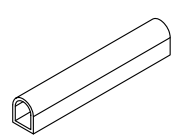



Barre renforcée pour fixation du moteur.  
Reinforced bar for motor fixation.  
Verstärkte Stange zur Motorbefestigung.  
Barra reforzada para fijación del motor.  
Barra rinforzata per fissaggio motore.  
Versterkte staaf voor motorfixatie.  
Barra reforçada para fixação do motor.  
Wzmocniony drążek do mocowania silnika.

| NO. | Section  | UV08-2D   | UV08-5D   | UV08-6D   |
|-----|--|-----------|-----------|-----------|
|     |  | QTY (pcs) | QTY (pcs) | QTY (pcs) |
| 18  | <br>M4*16 | 4         | 4         | 4         |
| 20  |          | 1         | 1         | 1         |
| 31  |         | 2         | 2         | 2         |

| BOX 2/4 |   |           |           |           |
|---------|---|-----------|-----------|-----------|
| NO.     | Section   | UV08-2D   | UV08-5D   | UV08-6D   |
|         |   | QTY (pcs) | QTY (pcs) | QTY (pcs) |
| 6       |  | 20        | 22        | 26        |
| 7       |  | 14        | 16        | 20        |

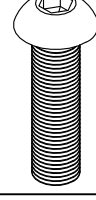

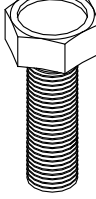
| BOX 3/4 |   |           |           |           |
|---------|---|-----------|-----------|-----------|
| NO.     | Section   | UV08-2D   | UV08-5D   | UV08-6D   |
|         |   | QTY (pcs) | QTY (pcs) | QTY (pcs) |
| 32      |  | 7         | 7         | 8         |

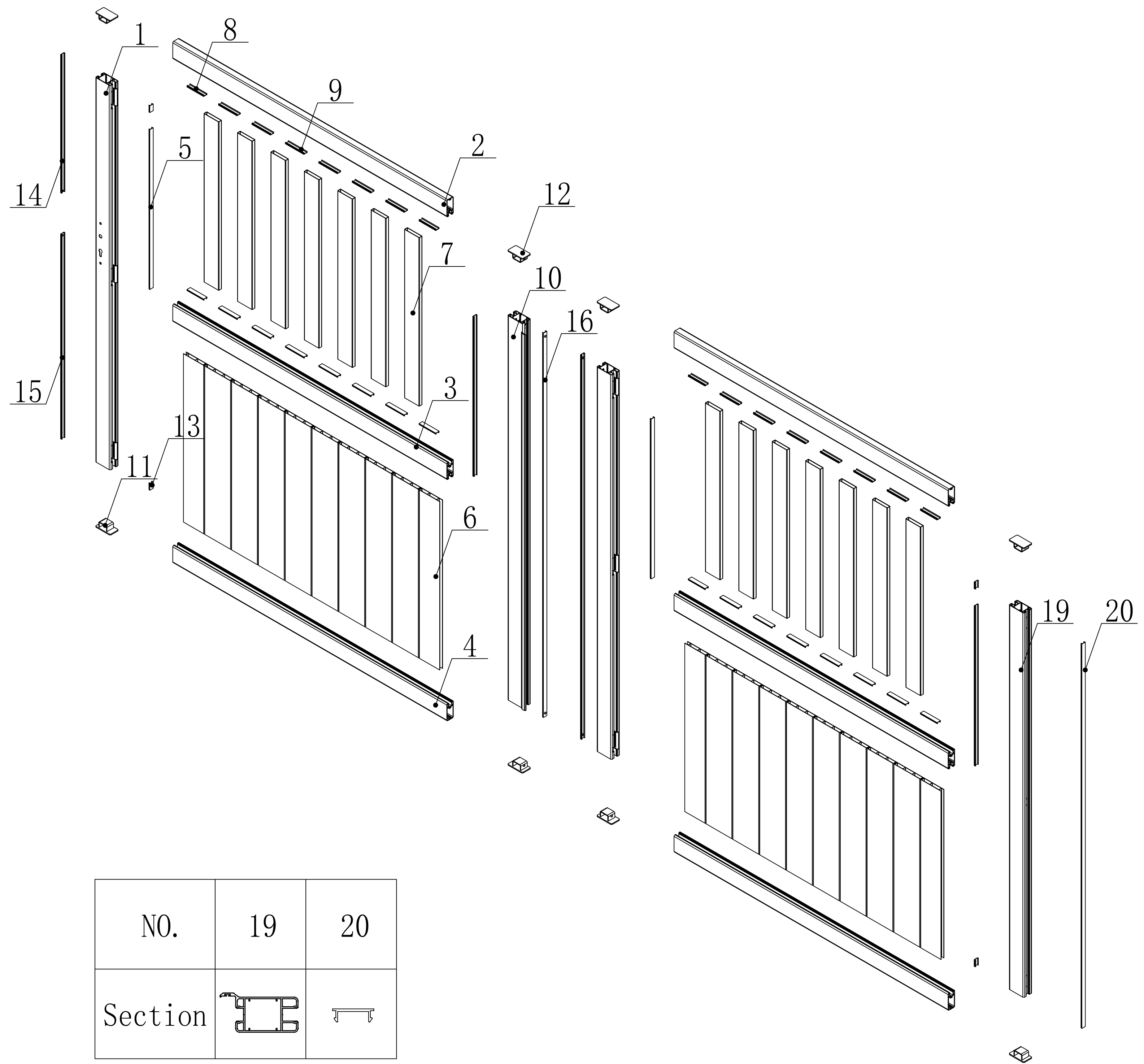

| BOX 4/4 |   |           |           |
|---------|---|-----------|-----------|
| NO.     | Section   | UV08-5D   | UV08-6D   |
|         |   | QTY (pcs) | QTY (pcs) |
| 33      |    | 1         | 1         |
| 34      |    | 1         | 1         |
| 35      |    | 2         | 2         |
| 36      |    | 1         | 1         |
| 37      |  | 1         | 1         |
| 38      |  | 1         | 1         |
| 39      |  | 3         | 3         |
| 40      |  | 1         | 1         |
| 41      |  | 1         | 1         |
| 42      |  | 4         | 4         |
| 43      |  | 6         | 7         |

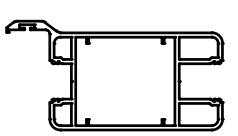
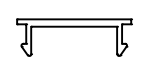
| NO. | Section   | UV08-5D   | UV08-6D   |
|-----|---|-----------|-----------|
|     |   | QTY (pcs) | QTY (pcs) |
| 44  |    | 4         | 4         |
| 45  |    | 4         | 4         |
| 46  |    | 2         | 2         |
| 47  |    | X         | X         |
| 48  |    | 9         | 9         |
| 49  |  | 2         | 2         |
| 50  |  | 2         | 2         |
| 51  |  | 8         | 8         |
| 52  |  | 4         | 4         |
| 53  |  | 2         | 2         |
| 54  |  | 1         | 1         |

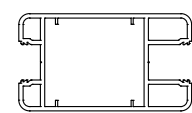
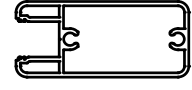
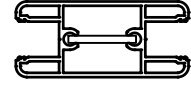
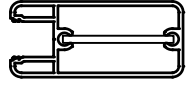
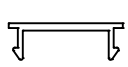

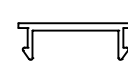
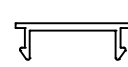
|         |   |   |
|---------|---|---|
| NO.     | 19  | 20  |
| Section |  |  |

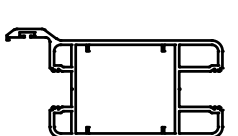
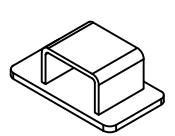
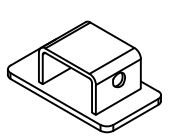
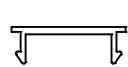
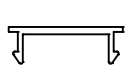
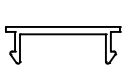
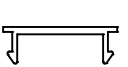
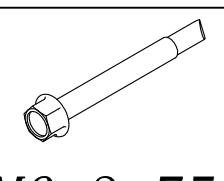
|         |   |   |   |  |   |   |   |   |   |
|---------|---|---|---|--|---|---|---|---|---|
| NO.     | 1   | 2   | 3   | 4  | 5   | 6   | 7   | 8   | 9   |
| Section |  |  |  |  |  |  |  |  |  |

|         |   |   |   |  |   |   |   |   |   |
|---------|---|---|---|--|---|---|---|---|---|
| NO.     | 10  | 11  | 12  | 13   | 14  | 15  | 16  | 17  | 18  |
| Section |  |  |  |  |  |  |  |  |  |
|         |   |   |   |  |   |   |   | M6. 3*75  | M4*16   |

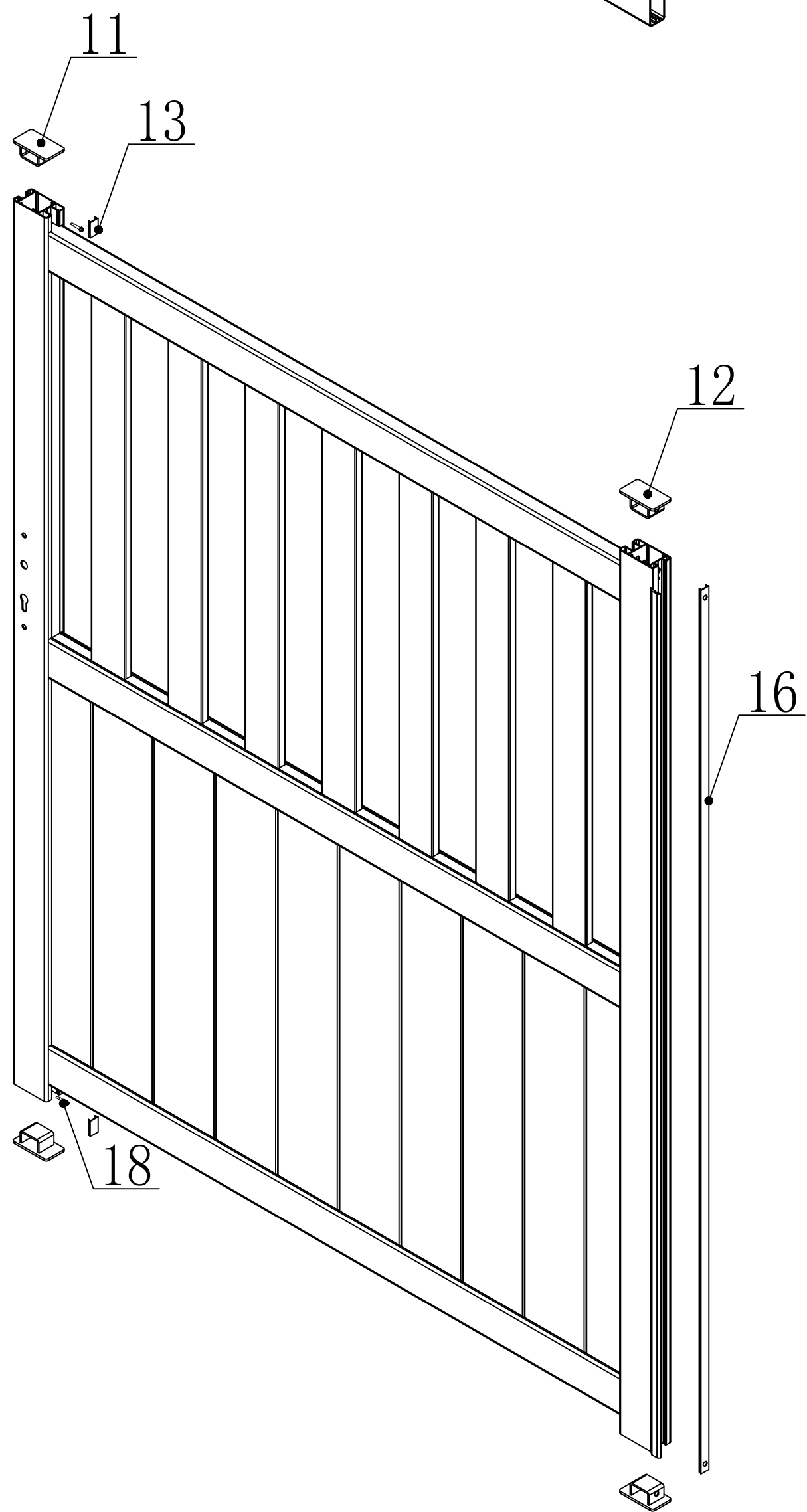
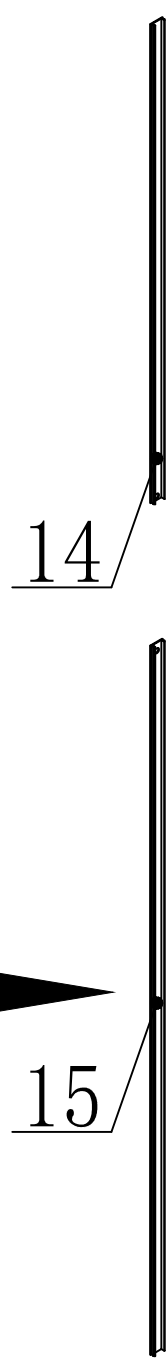
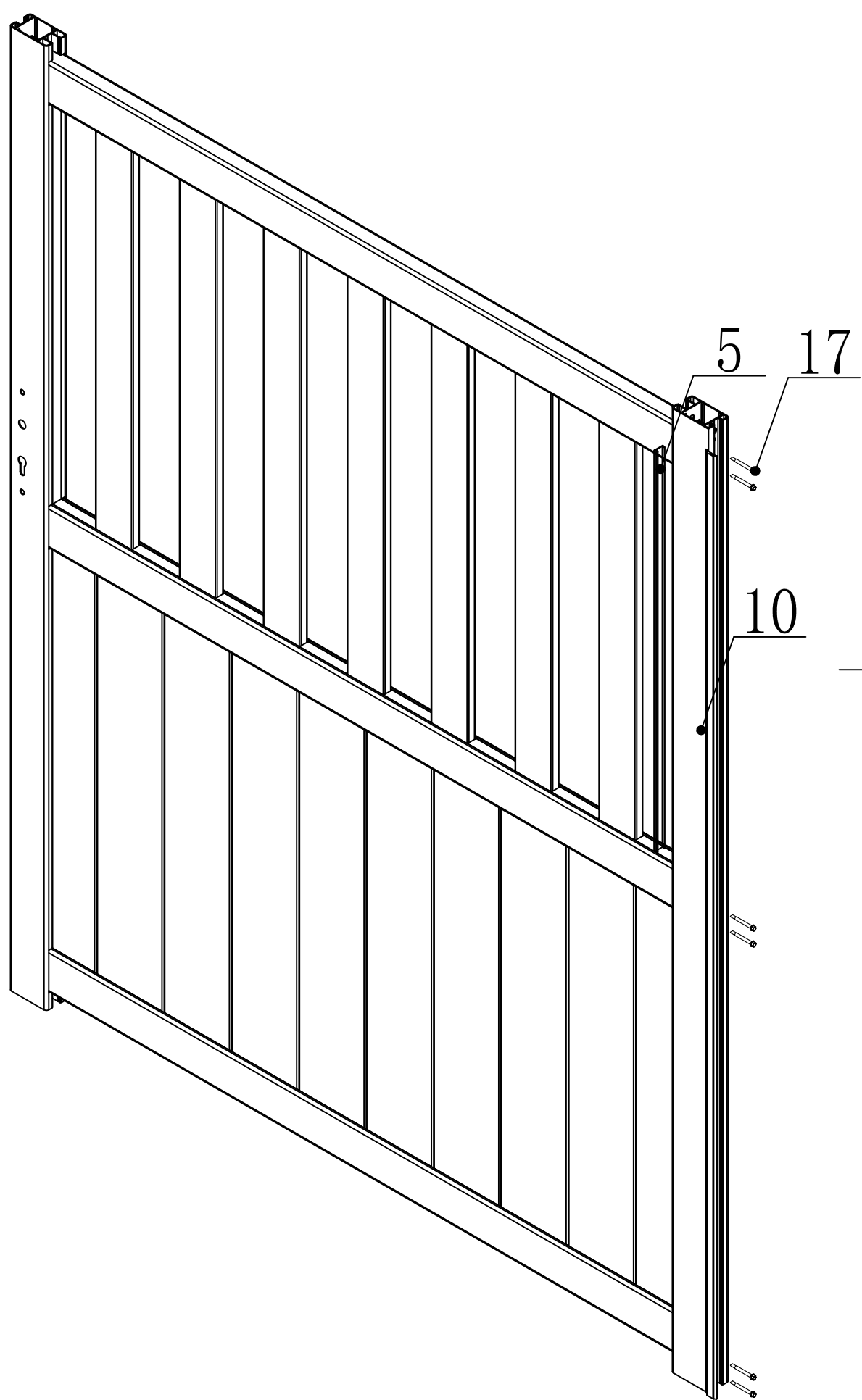
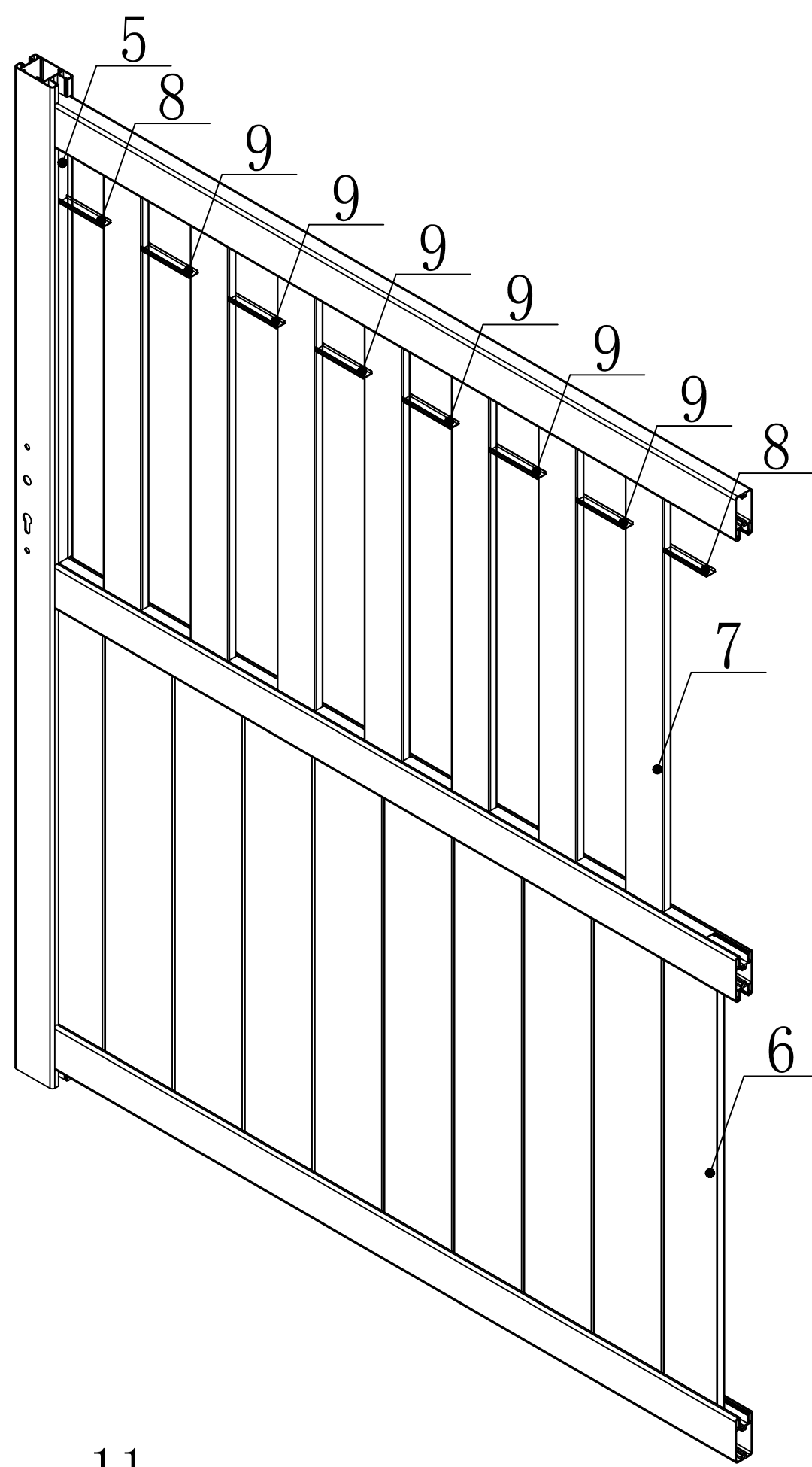
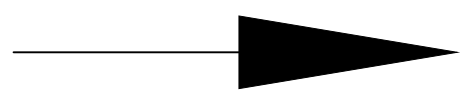
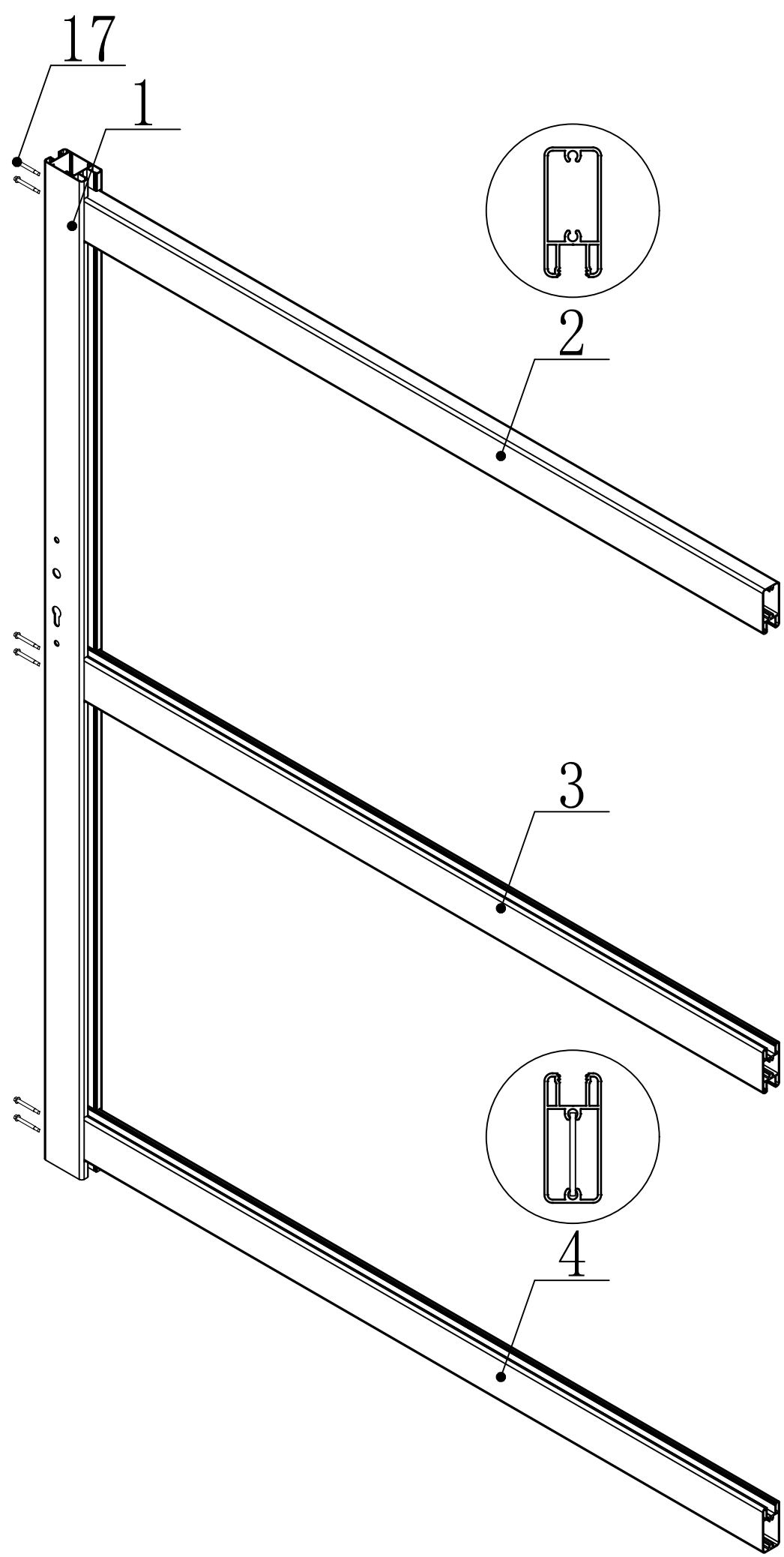

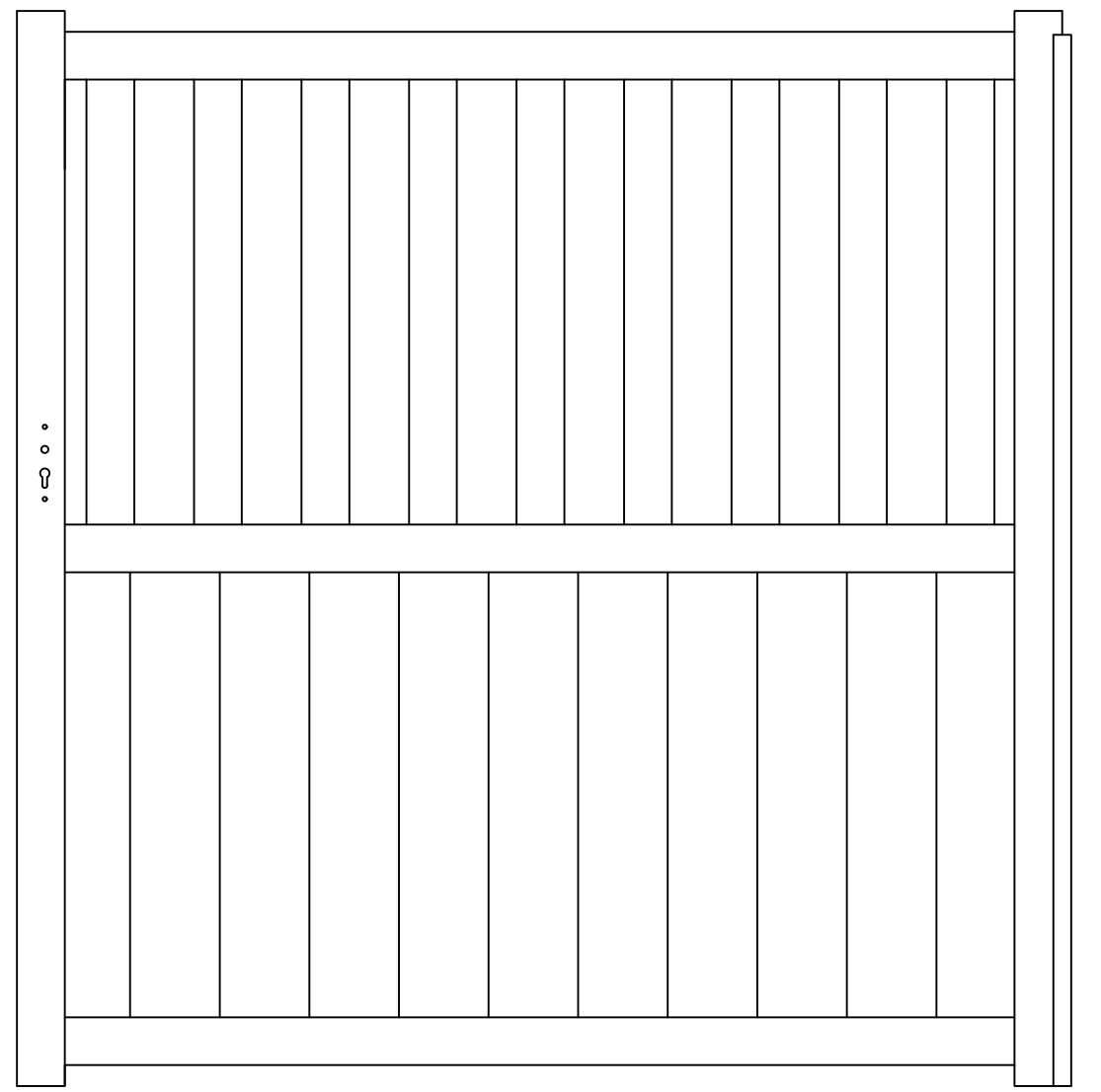
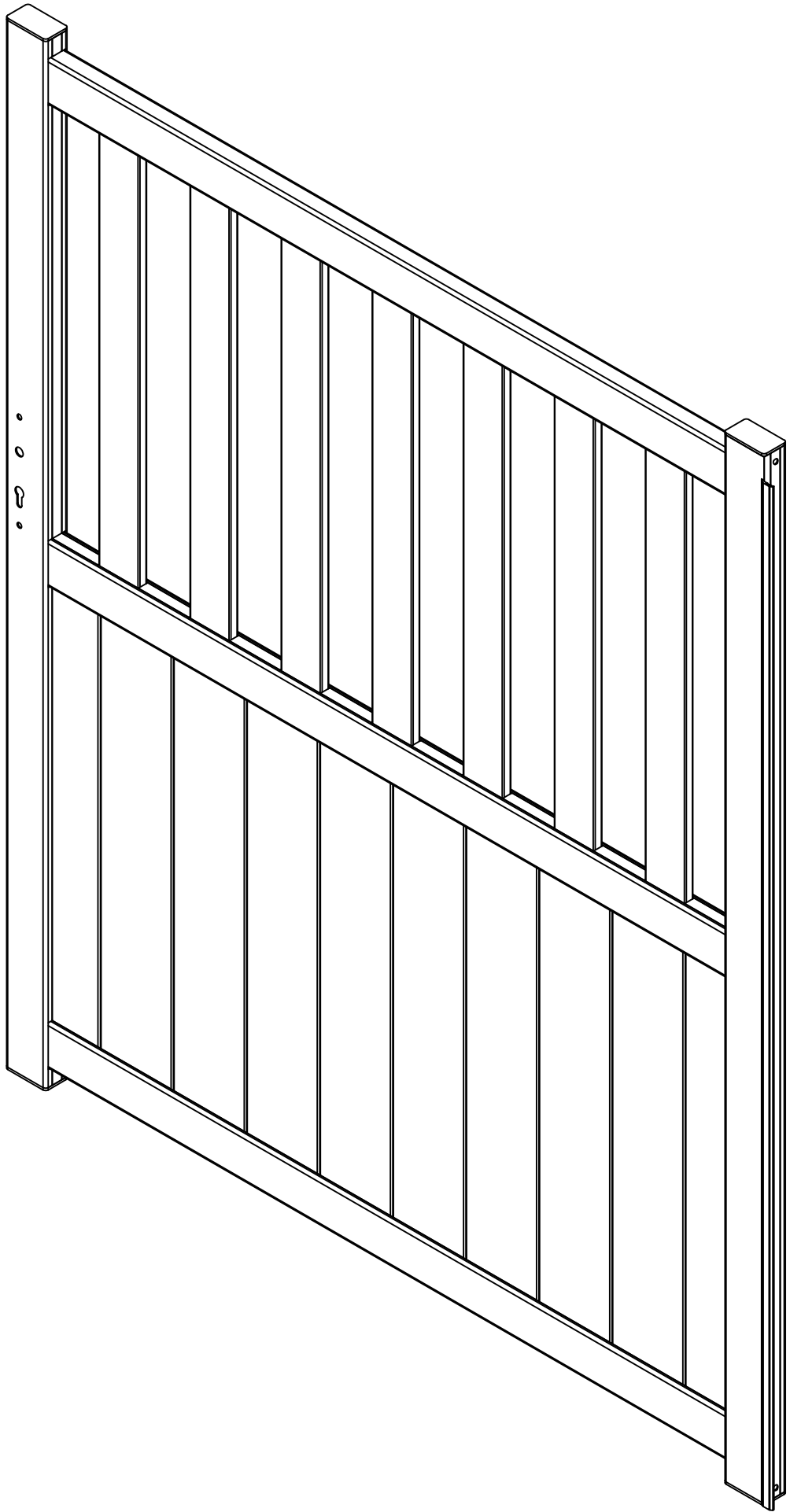

[B]

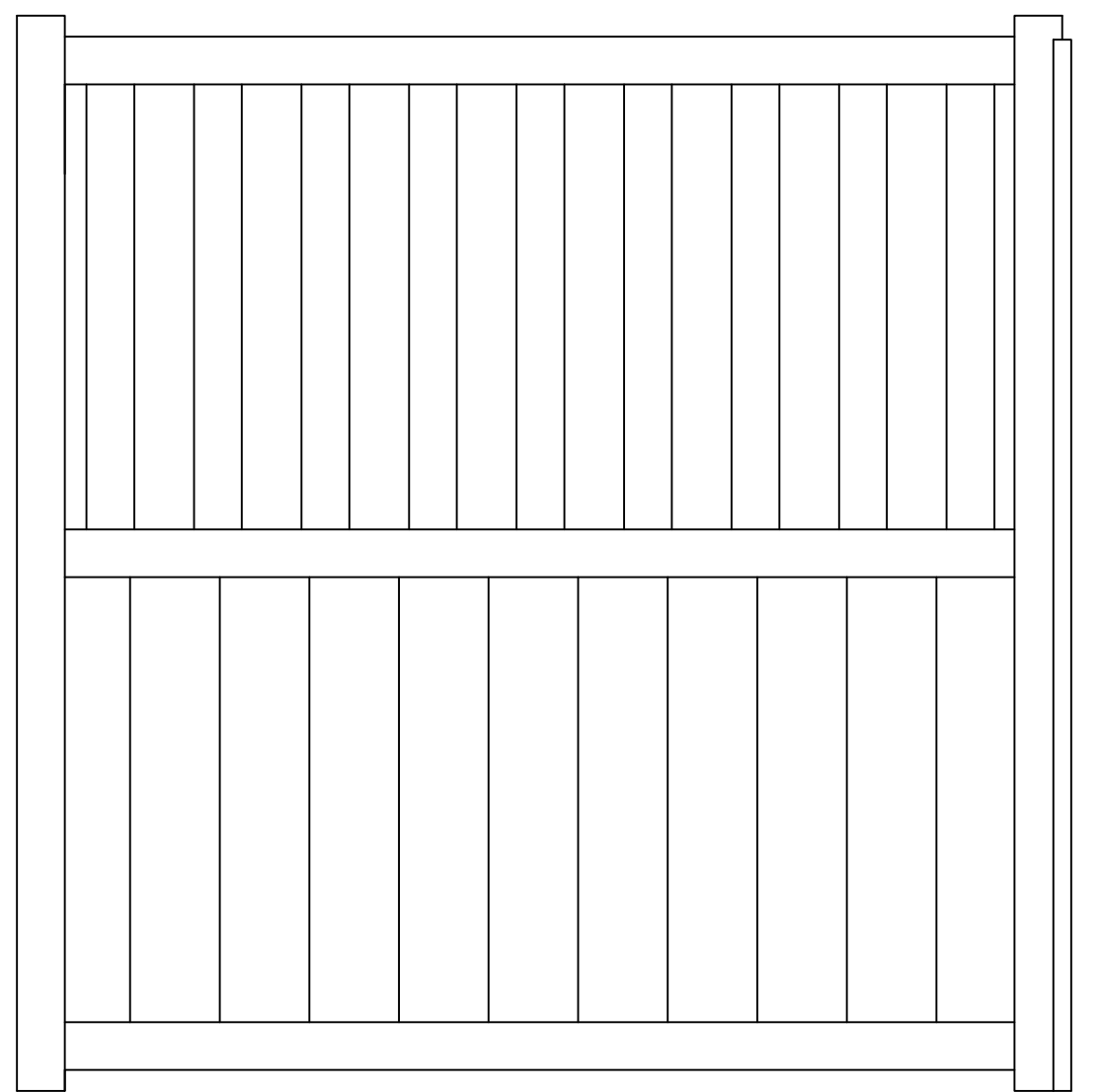
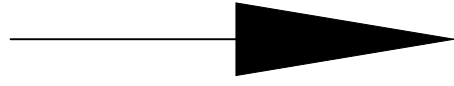
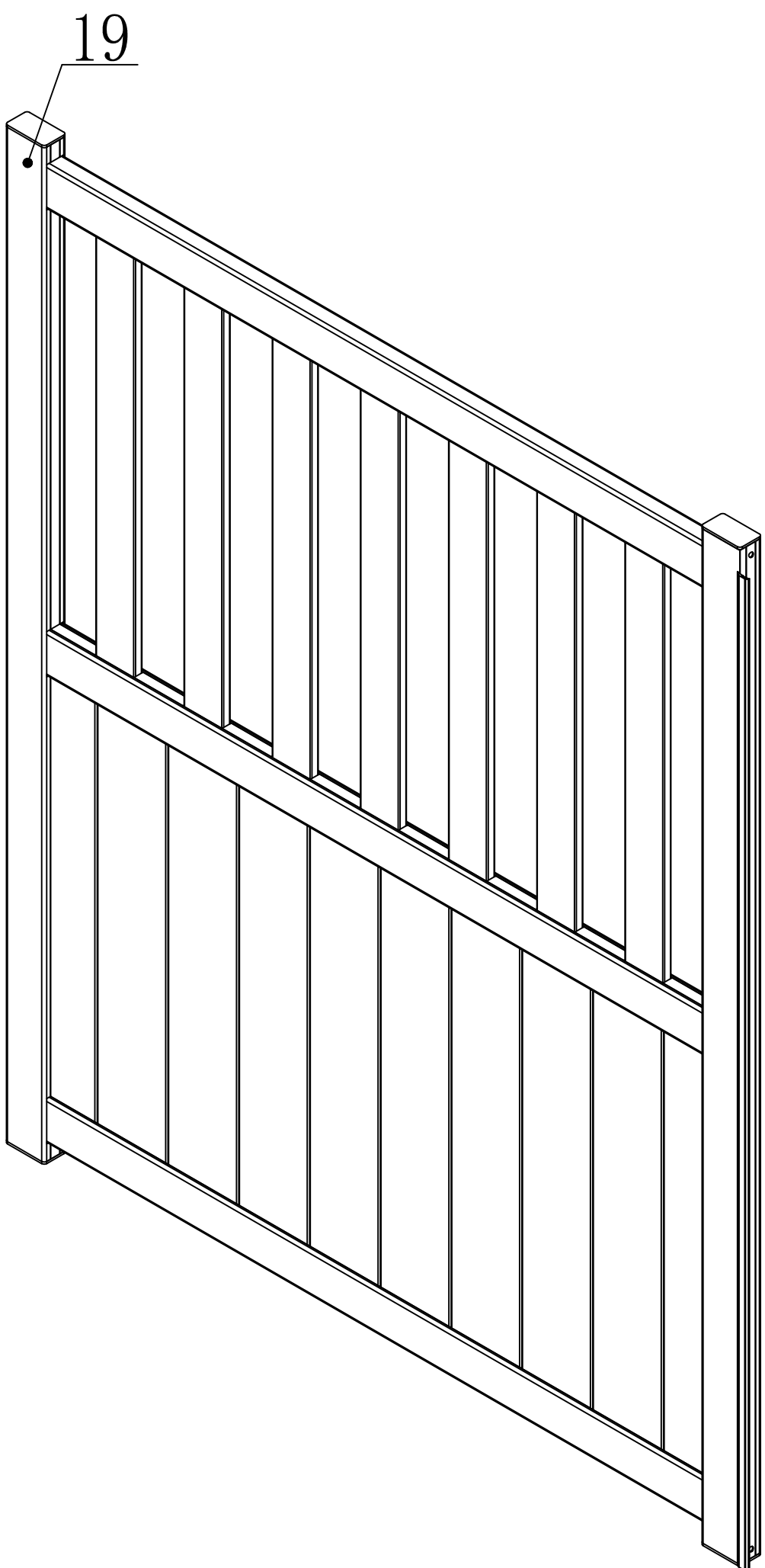

[A]

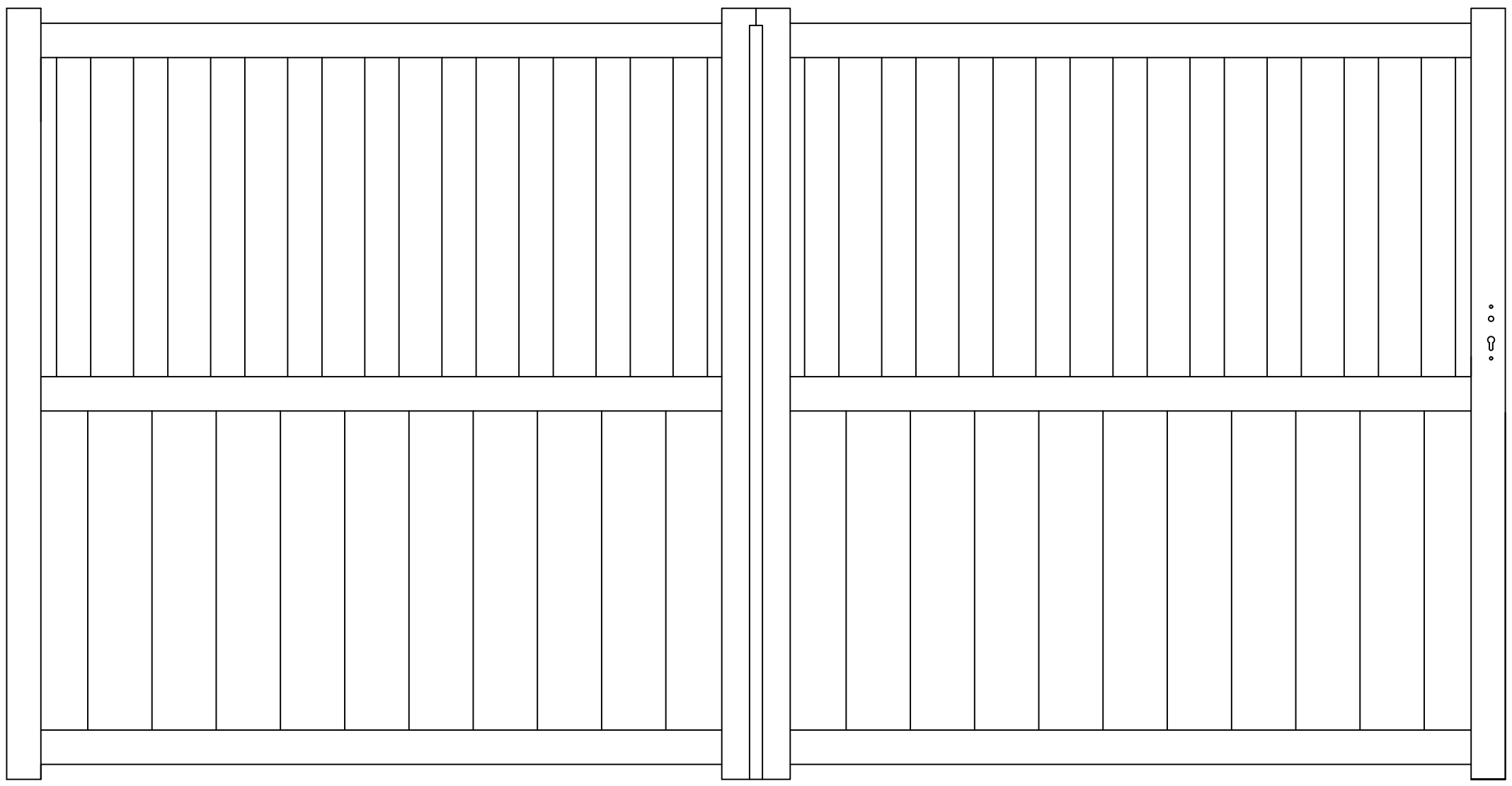

[A]\*1

[B]\*1

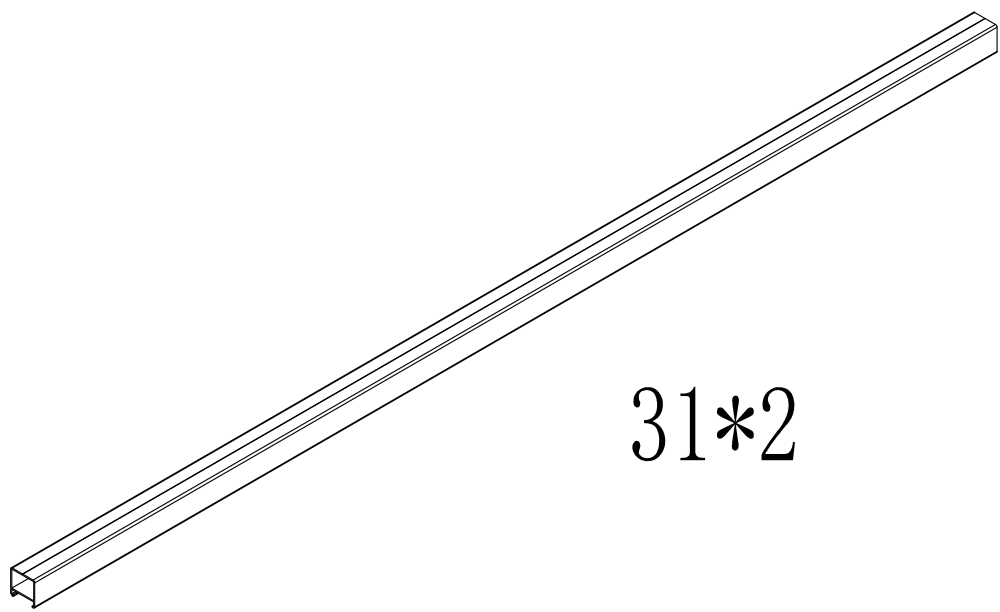

31\*2

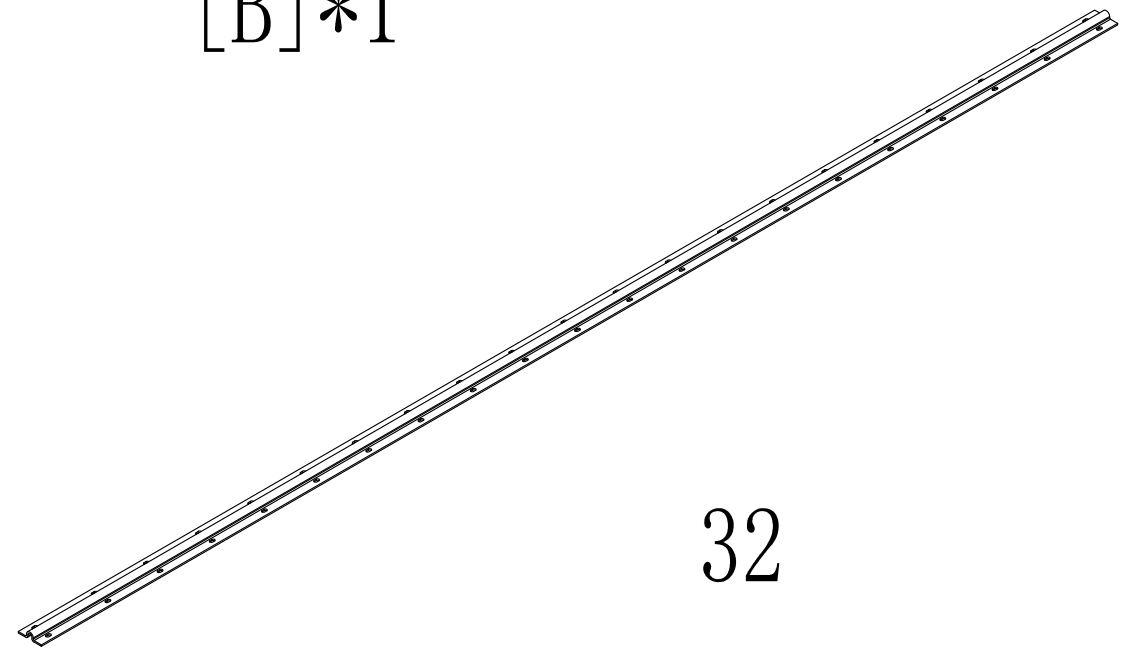

32

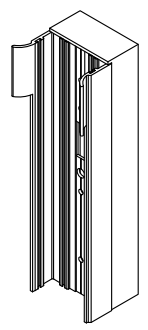

33\*1

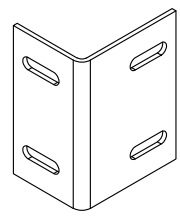

34\*1

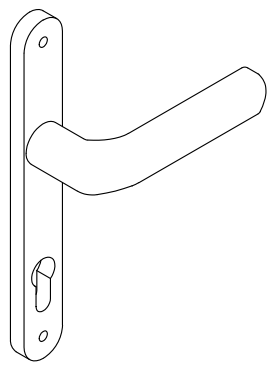

35\*2

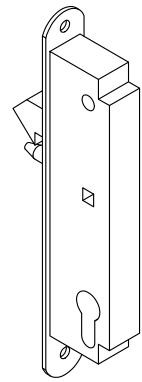

36\*1

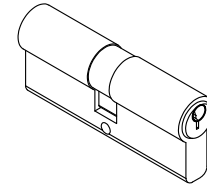

37\*1

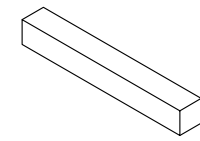

38\*1

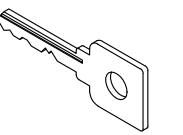

39\*3

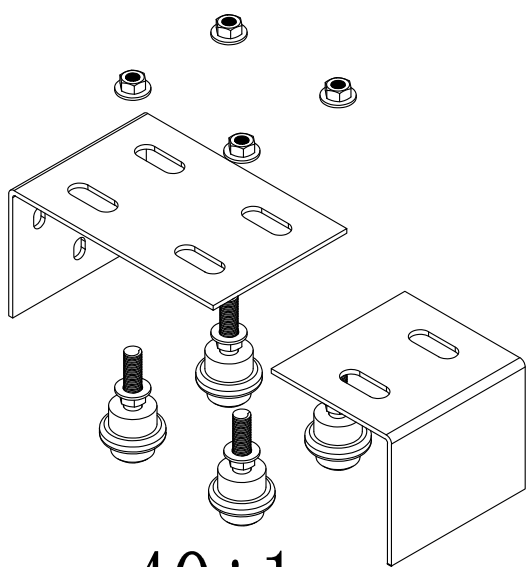

40\*1

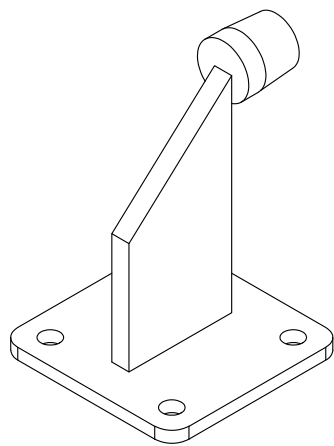

41\*1

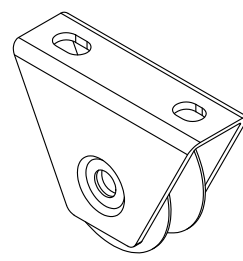

42\*4

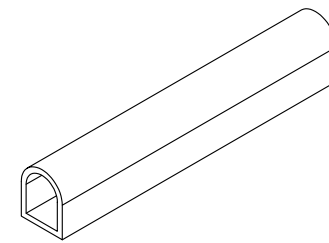

43



44\*4

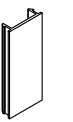

45\*4



46\*2

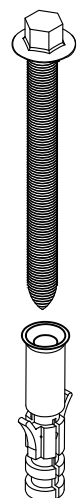

47\*~~X~~

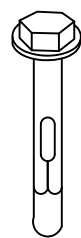

48\*9



49\*2



50\*2

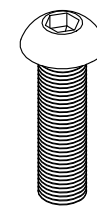

51\*8



52\*4

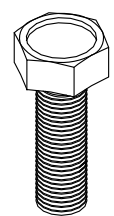

53\*2



54\*1



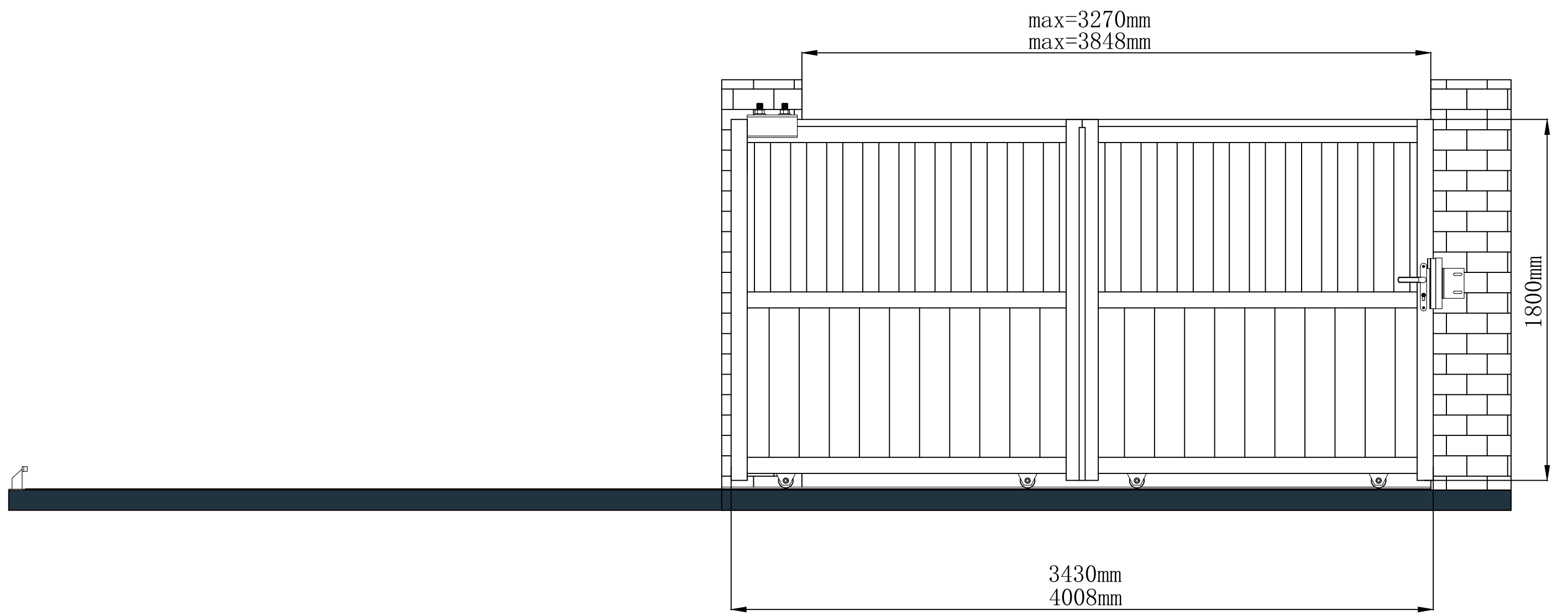
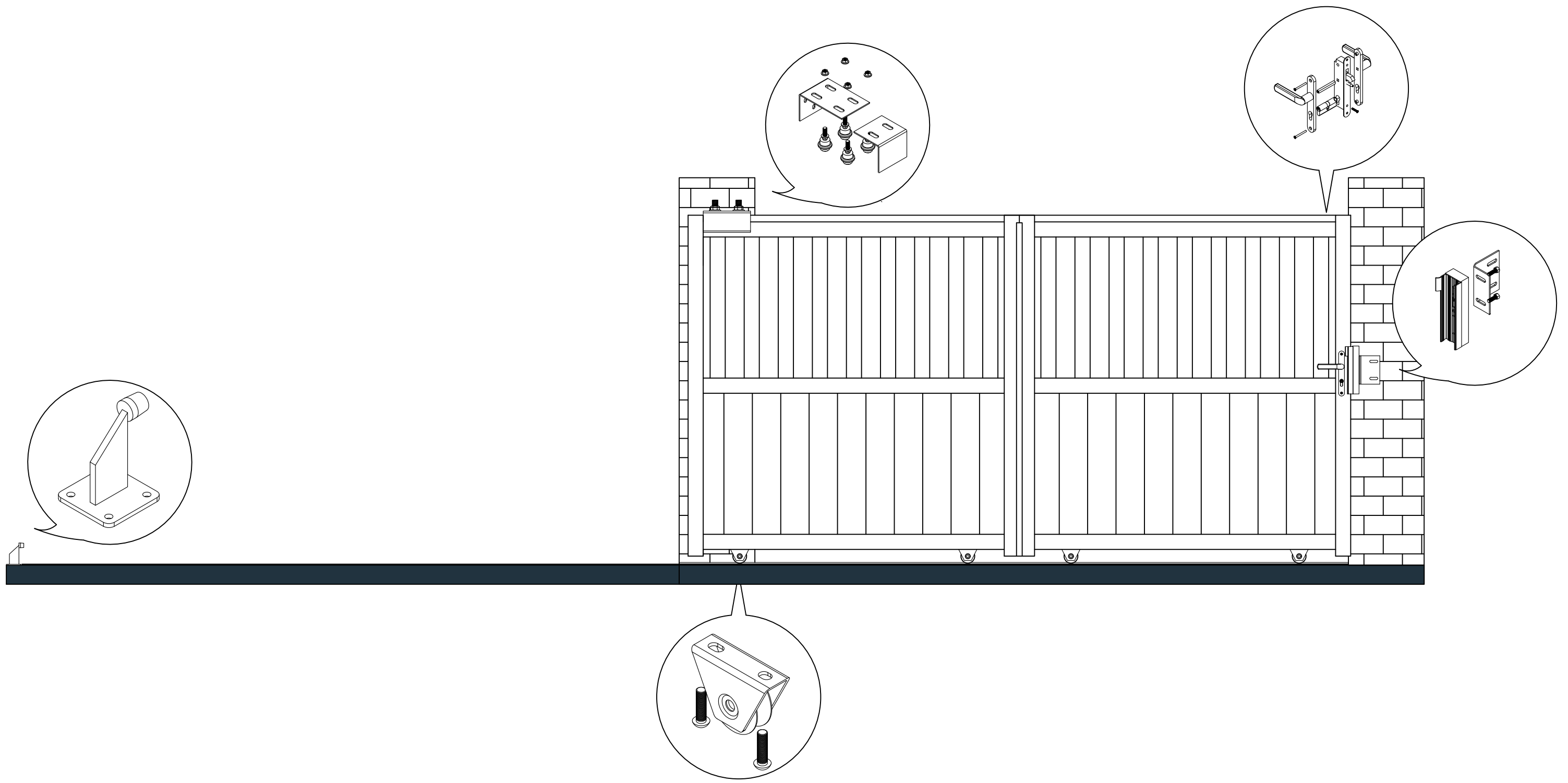

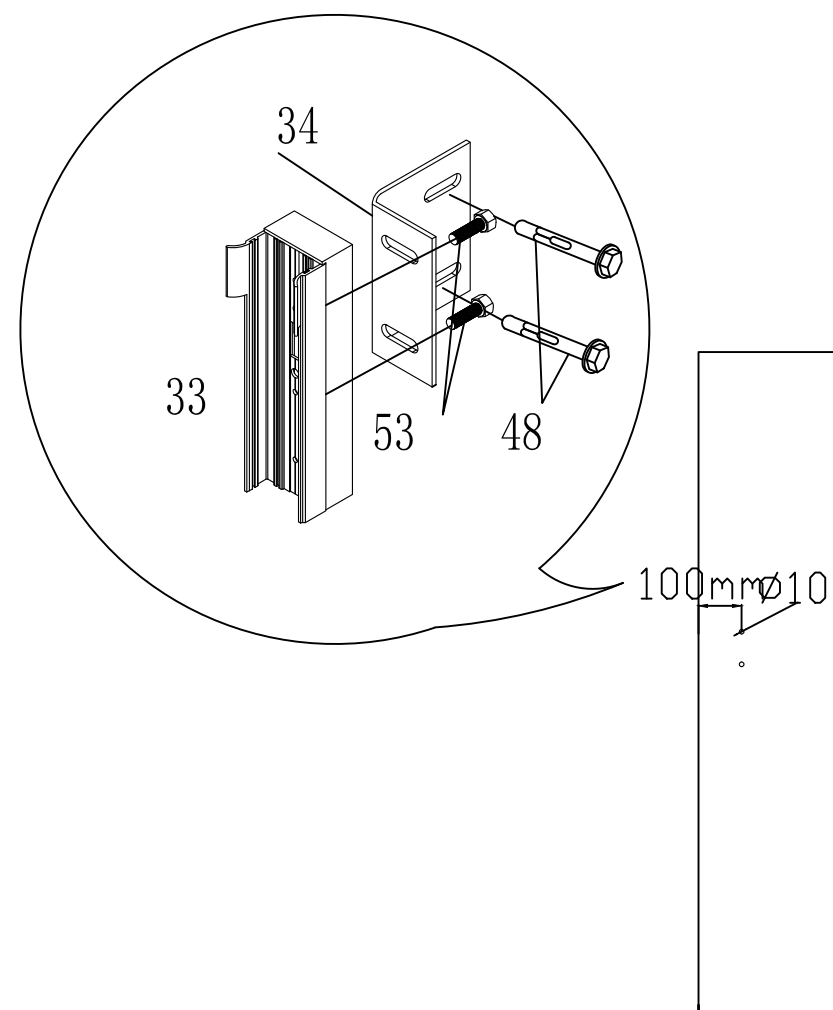
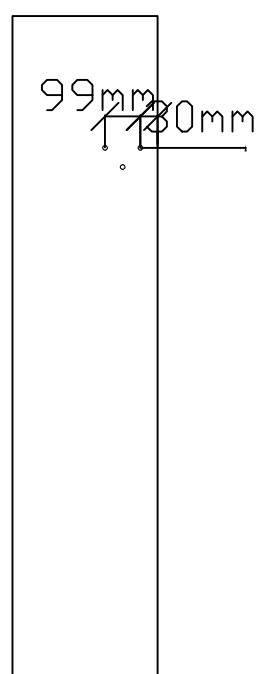
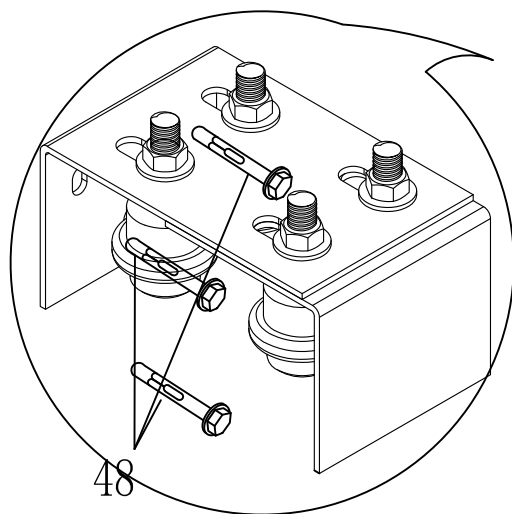
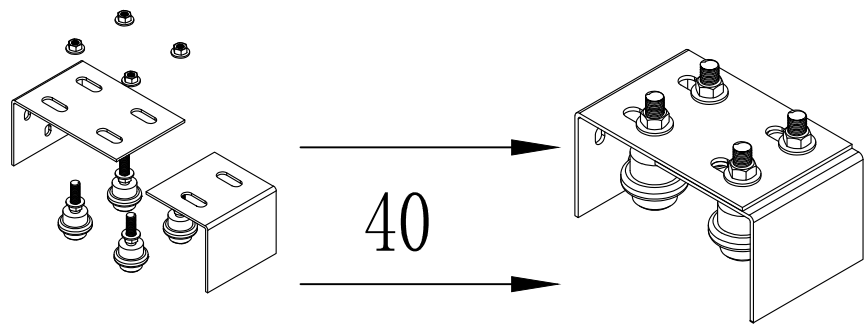
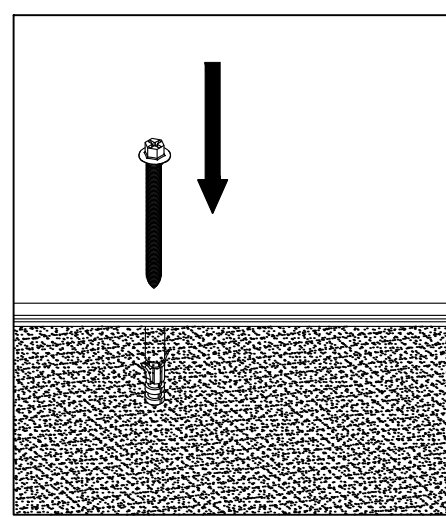
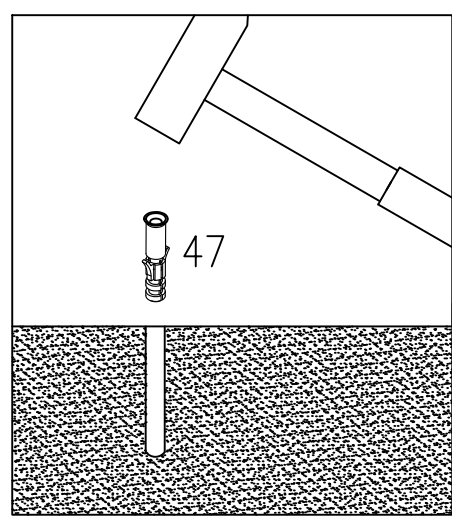
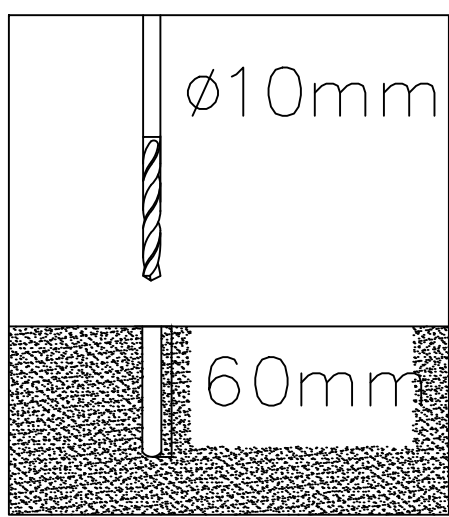
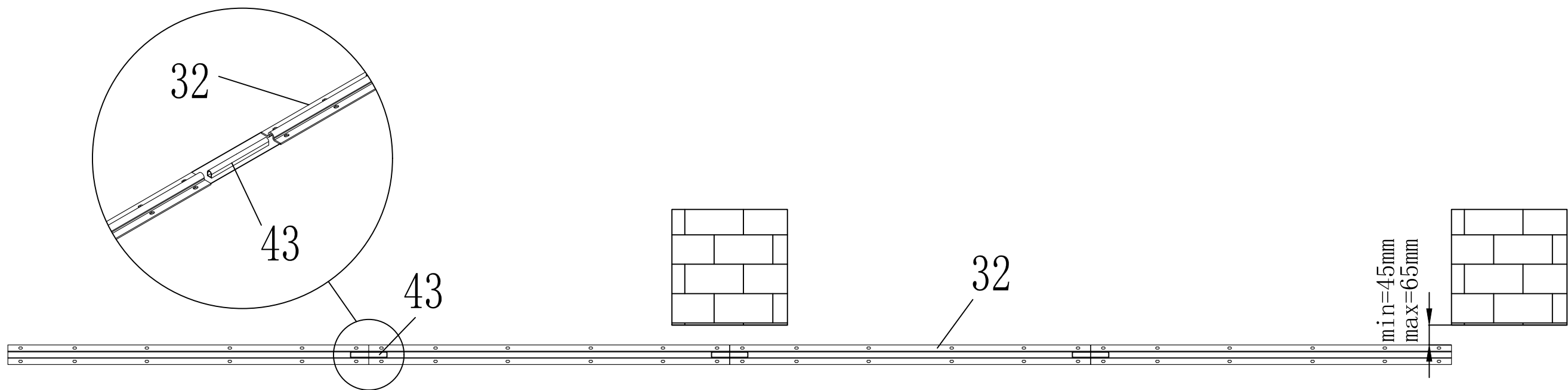
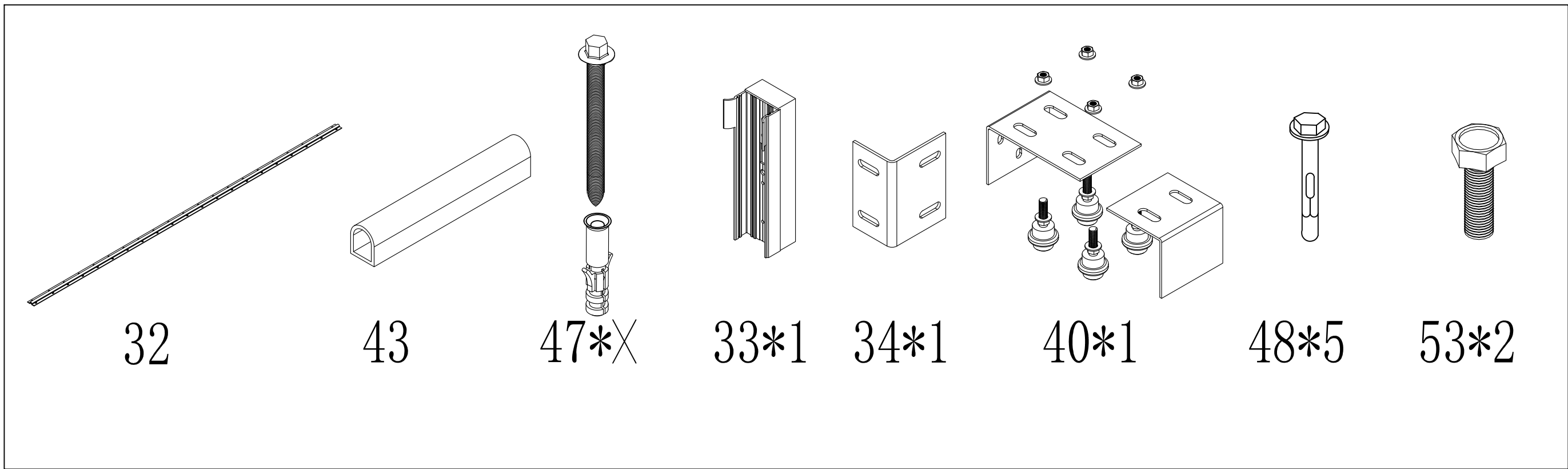

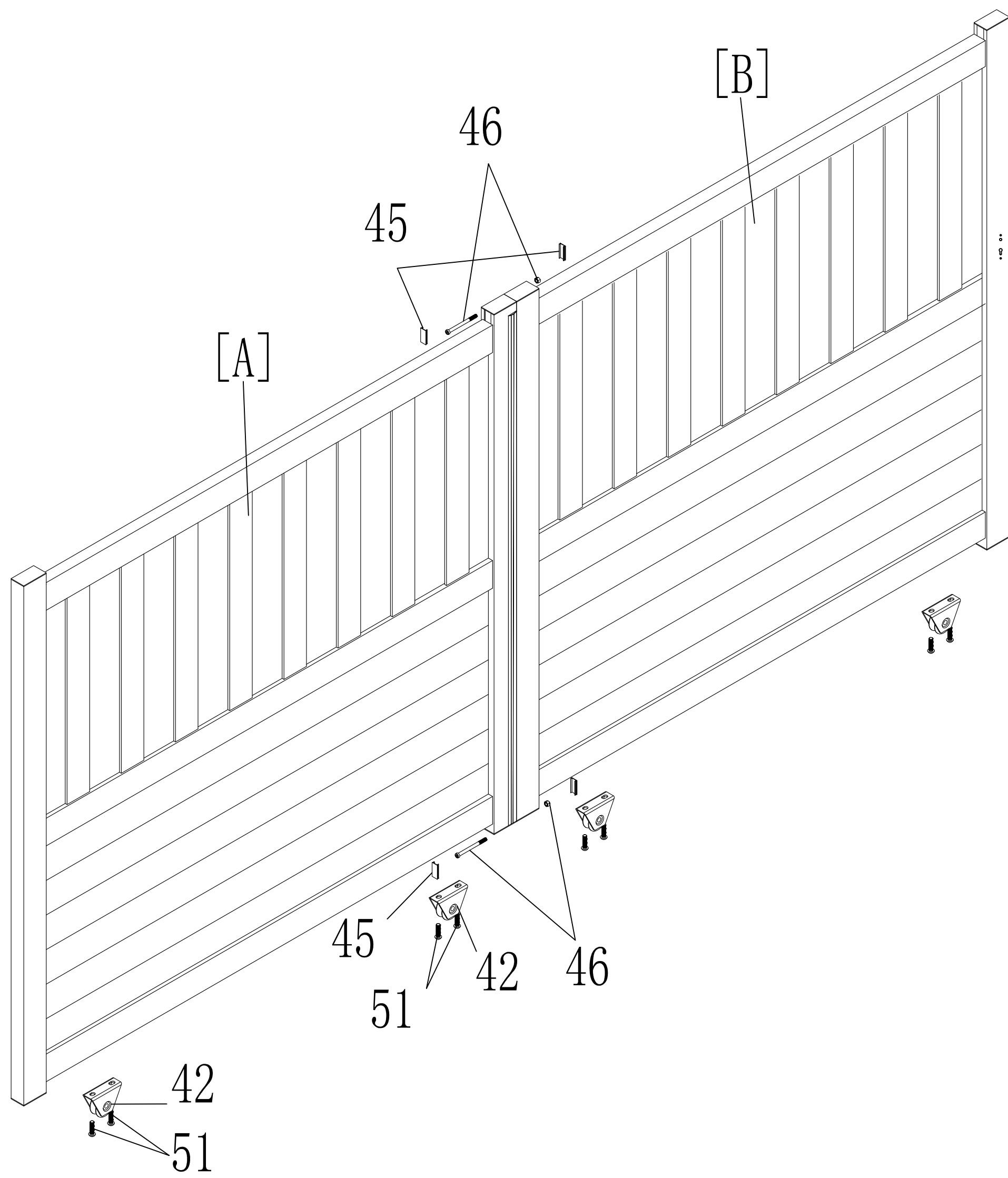
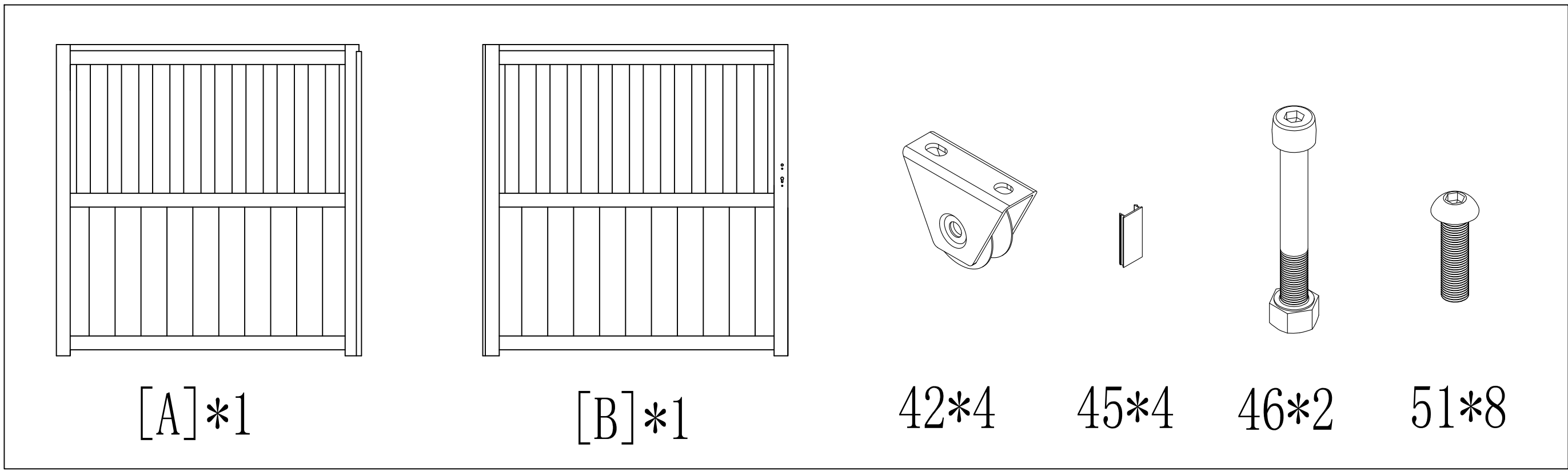

FR

Attention:

1. Si vous rencontrez des difficultés lors du montage des vis n ° 49 sur la poignée (35), veuillez desserrer les vis du corps de verrouillage, puis réessayer.
2. Pls justifient le cylindre (37) aux trous de cylindre pré-perçés lors de l'installation du cylindre (37) sur la porte.

EN

Attention:

1. If you have difficulties when mounting No.49 screws on handle ( 35), pls loose the lock body screws, then try again.
2. Pls justify the cylinder (37 ) to the pre-drilled cylinder holes when install the cylinder (37 ) on gate.

DE

Beachtung:

1. Wenn Sie Schwierigkeiten beim Anbringen der Schrauben Nr. 49 am Griff (35) haben, lösen Sie bitte die Schrauben des Verriegelungskörpers und versuchen Sie es erneut.
2. Pls begründen den Zylinder (37) mit den vorgebohrten Zylinderlöchern, wenn der Zylinder (37) am Tor installiert wird.

ES

Atención:

1. Si tiene dificultades para montar los tornillos n. ° 49 en el mango (35), suelte los tornillos del cuerpo de la cerradura y vuelva a intentarlo.
2. Por favor, justifique el cilindro (37) en los orificios del cilindro pretaladrados cuando instale el cilindro (37) en la puerta.

IT

Attenzione:

1. In caso di difficoltà durante il montaggio delle viti n. 49 sulla maniglia (35), allentare le viti del corpo della serratura, quindi riprovare.
2. Pls giustificare il cilindro (37) ai fori del cilindro preforati quando si installa il cilindro (37) sul cancello.

NL

Aandacht:

1. Als u problemen ondervindt bij het monteren van nr. 49 schroeven op de handgreep (35), verwijder dan de schroeven van het slotlichaam en probeer het opnieuw.
2. Plug de cilinder (37) naar de voorgeboorde cilindergaten wanneer de cilinder (37) op de poort wordt geïnstalleerd.

PT

Atenção:

1. Se tiver dificuldades ao montar parafusos no.49 na pega (35), os parafusos do carro de bloqueio soltam-se e tente novamente.
2. As pls justificam o cilindro (37) com os furos do cilindro pré-perfurado quando instalar o cilindro (37) no portão.

PL

Uwaga:

1. Jeś li masz trudnoś ci podczas montaż u nr 49 na uchwycie (35), pls luź ne korpusu zamka, a następnie spróbuj ponownie.
2. Pls uzasadniajć cylinder (37) do wstępnie wywierconych otworów cylindra podczas instalowania cylindra (37) na bramce.

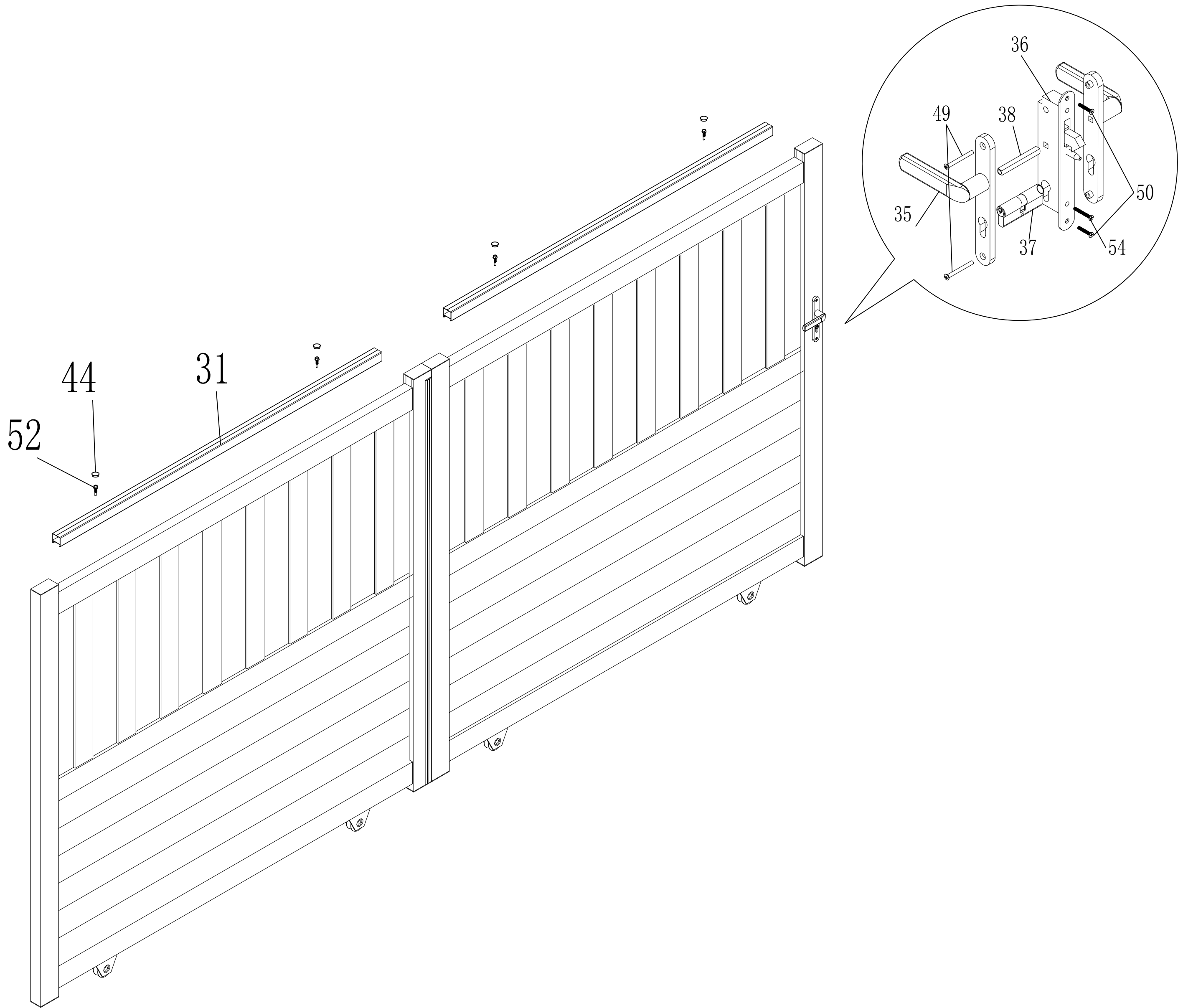
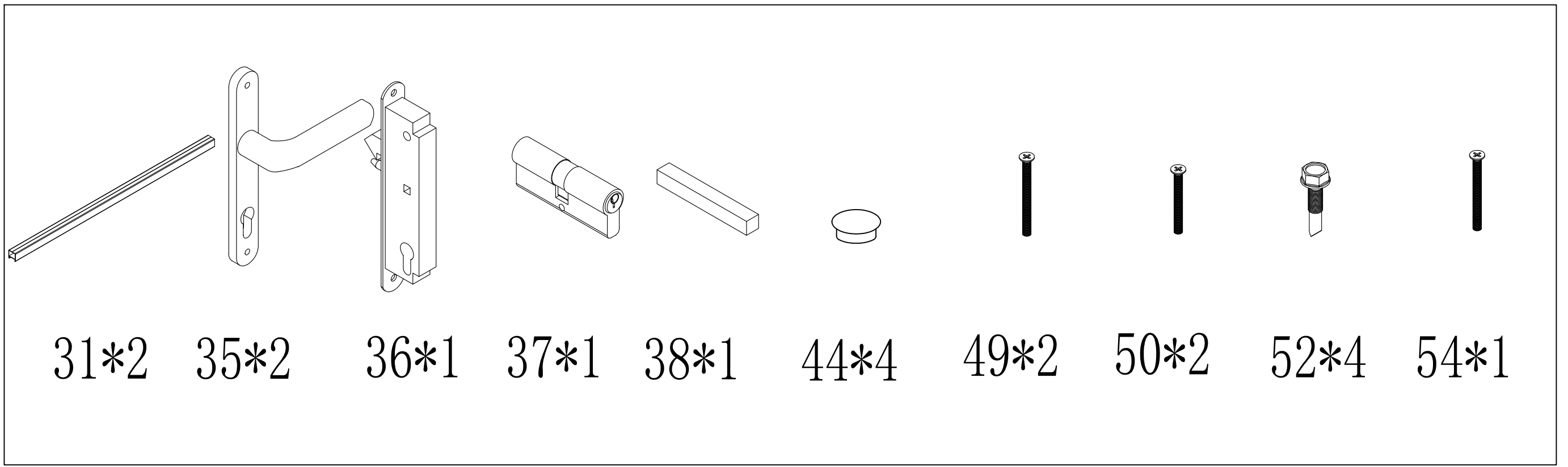

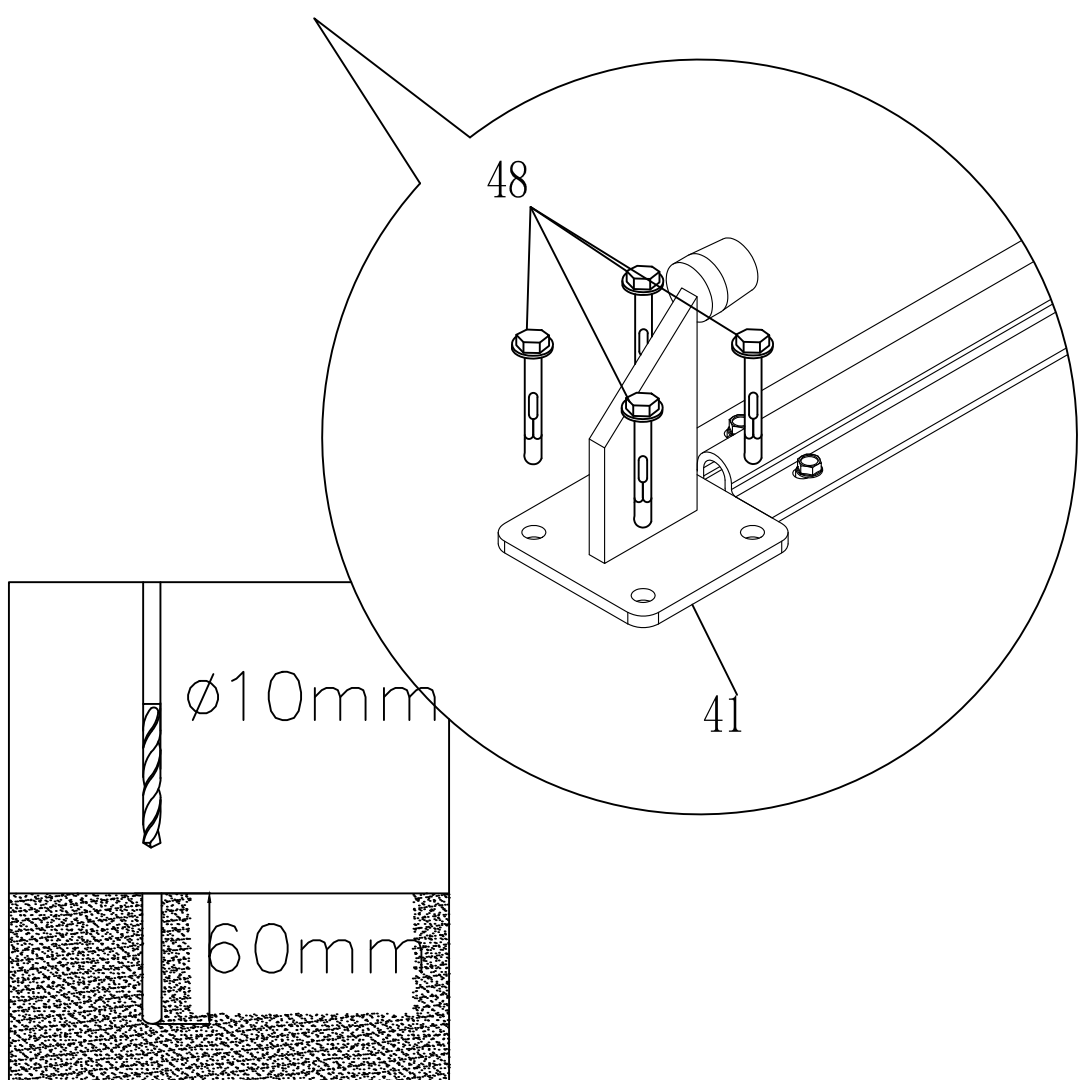
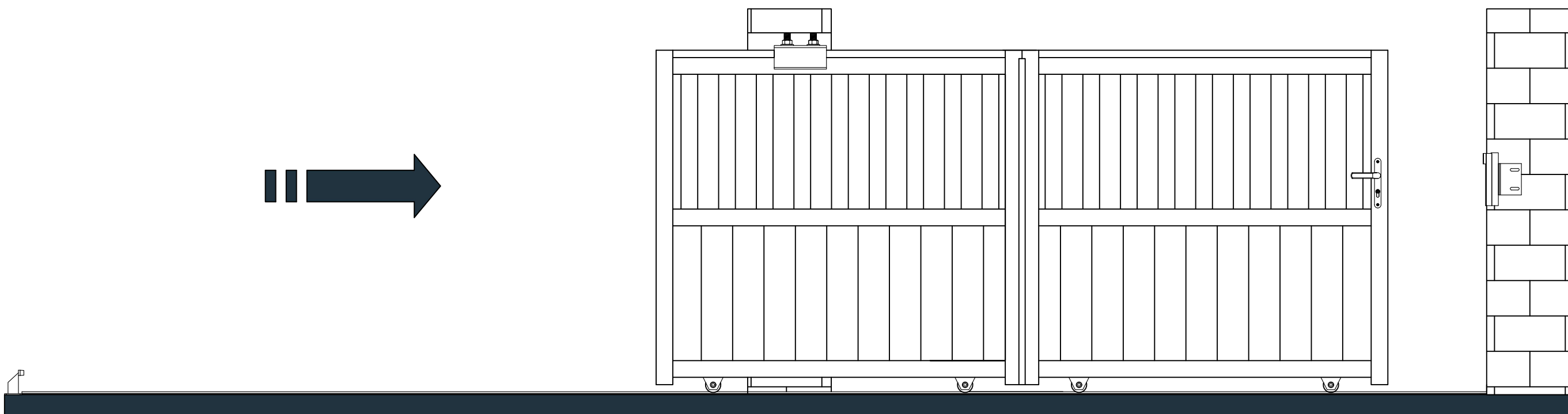

FR

*Attention (pour installation de portail motorisé uniquement):*

*En cas de portail coulissant motorisé, les étapes d'installation de la serrure sont à suivre comme ci-dessous, les autres étapes sont les mêmes.*

*Pour l'installation du moteur, veuillez vous référer au moteur IM.*

EN

*Attention (For motorized gate installation only):*

*If motorized sliding gate, the installing steps for the lock is to follow as below, other steps are the same.*

*For motor installation, pls refer the motor IM.*

DE

*Achtung (nur für die Installation von motorisierten Toren):*

*Bei motorisiertem Schiebetor müssen die Installationsschritte für das Schloss wie folgt ausgeführt werden, andere Schritte sind die gleichen.*

*Für die Motorinstallation beziehen Sie sich bitte auf den Motor IM.*

ES

*Atención (solo para instalación de portón motorizado):*

*Si se trata de una puerta corredera motorizada, los pasos de instalación de la cerradura deben seguir los siguientes pasos, los demás pasos son los mismos.*

*Para la instalación del motor, consulte el motor IM.*

IT

*Attenzione (solo per installazione su cancello motorizzato):*

*In caso di cancello scorrevole motorizzato, le fasi di installazione della serratura devono essere seguite come sotto, le altre fasi sono le stesse.*

*Per l'installazione del motore, fare riferimento al motore IM.*

NL

*Let op (alleen voor gemotoriseerde poortinstallatie):*

*Als een gemotoriseerde schuifpoort, moeten de installatiestappen voor het slot worden gevolgd zoals hieronder, andere stappen zijn hetzelfde.*

*Raadpleeg voor motorinstallatie de motor IM.*

PT

*Atenção (apenas para instalação motorizada do portão):*

*Se o portão de correr motorizado, os passos de instalação para o bloqueio devem seguir como abaixo, outros passos são os mesmos.*

*Para a instalação do motor, consulte o motor IM.*

PL

*Uwaga (tylko w przypadku montażu bramy z napędem silnikowym):*

*Jeśli zmotoryzowana brama przesuwana, kroki instalacji zamka mają być następujące jak poniżej, inne kroki są takie same.*

*W przypadku instalacji silnika, proszę odnosić się do silnika IM.*



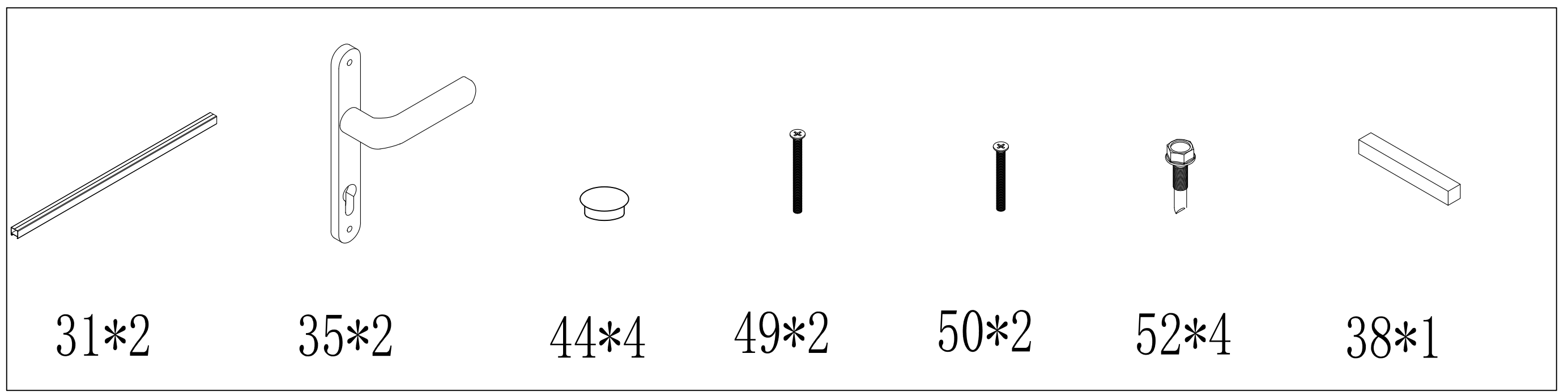

Installez le n ° 35 (poignée), le n ° 38 (barre carrée) par le n ° 49 (vis).

Install No.35 (Handle), No.38 (Square bar) by No.49 (Screw).

Installieren Sie Nr. 35 (Griff), Nr. 38 (Vierkantstange) bei Nr. 49 (Schraube).

Instale el n. ° 35 (mango), n. ° 38 (barra cuadrada) por n. ° 49 (tornillo).

Installare n. 35 (maniglia), n. 38 (barra quadrata) con n. 49 (vite).

Installeer nr. 35 (handvat), nr. 38 (vierkante staaf) door nr. 49 (schroef).

Instale No.35 (Alça), No.38 (Barra quadrada) pelo No.49 (Parafuso).

Zamontuj nr 35 (uchwyt), nr 38 (pręt kwadratowy) za nr 49 (śruba).

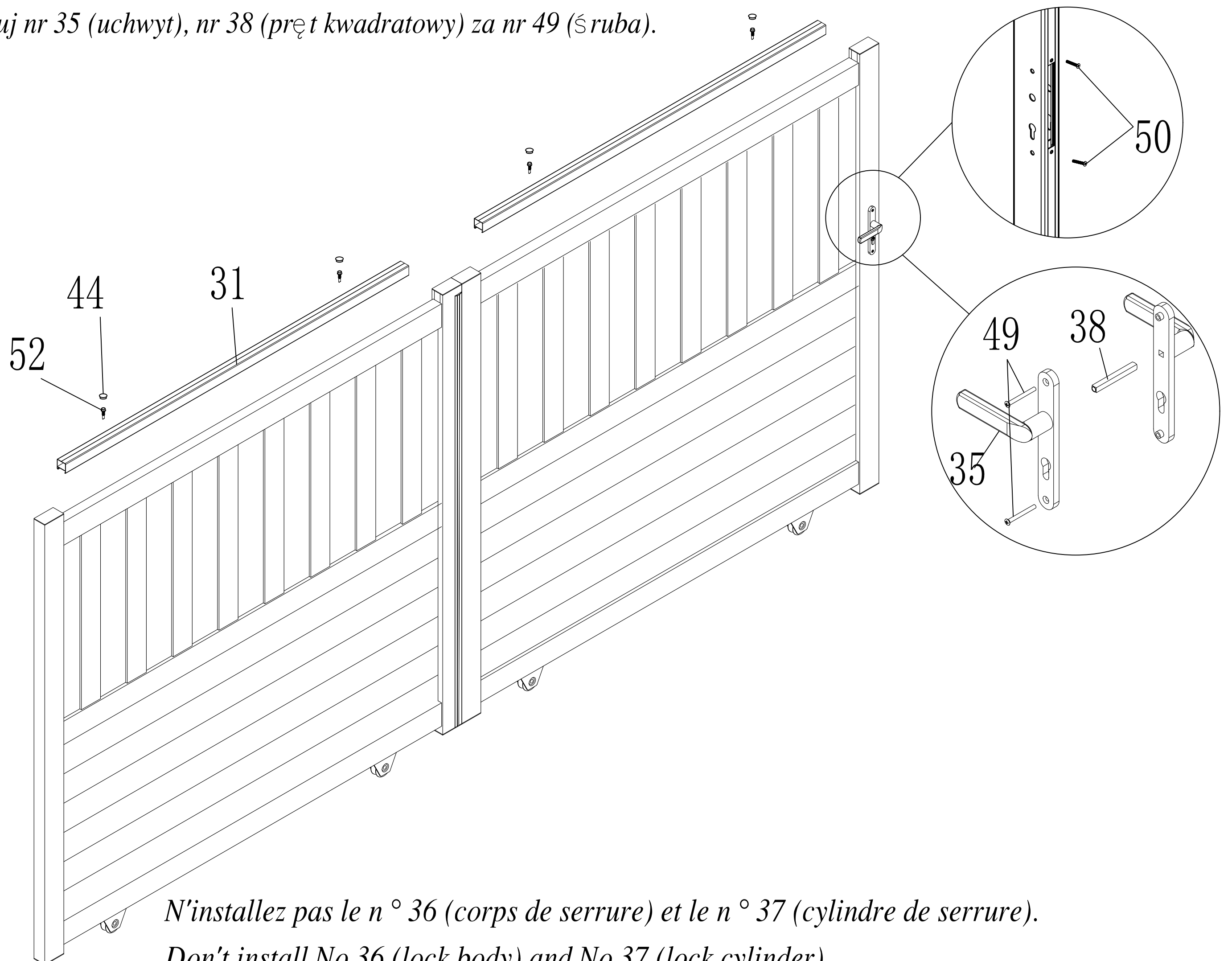

N'installez pas le n ° 36 (corps de serrure) et le n ° 37 (cylindre de serrure).

Don't install No.36 (lock body) and No.37 (lock cylinder).

Installieren Sie nicht Nr. 36 (Schließkörper) und Nr. 37 (Schließzylinder).

No instale el número 36 (cuerpo de la cerradura) y el número 37 (cilindro de la cerradura).

Non installare il numero 36 (corpo della serratura) e il numero 37 (cilindro della serratura).

Installeer nr. 36 (slotbehuizing) en nr.37 (slotcilinder) niet.

Não instale No.36 (corpo da fechadura) e No.37 (cilindro da fechadura).

Nie instaluj nr 36 (korpus zamka) i nr 37 (bę benek zamka).

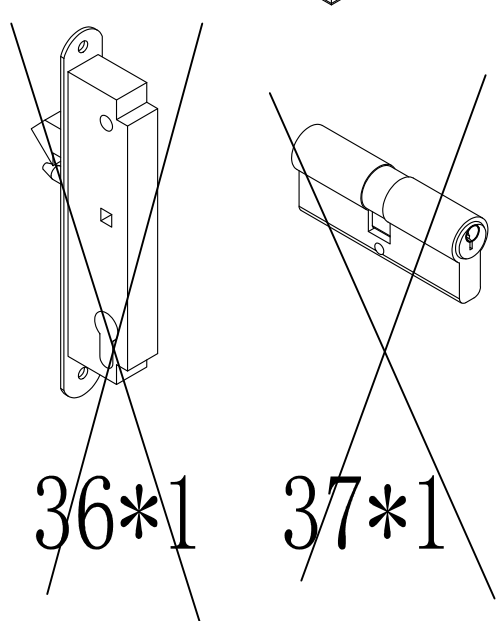



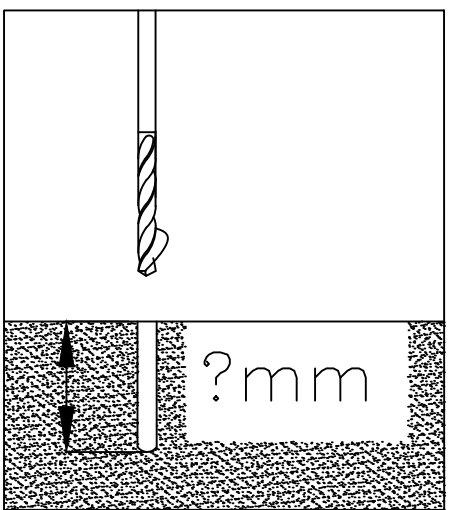
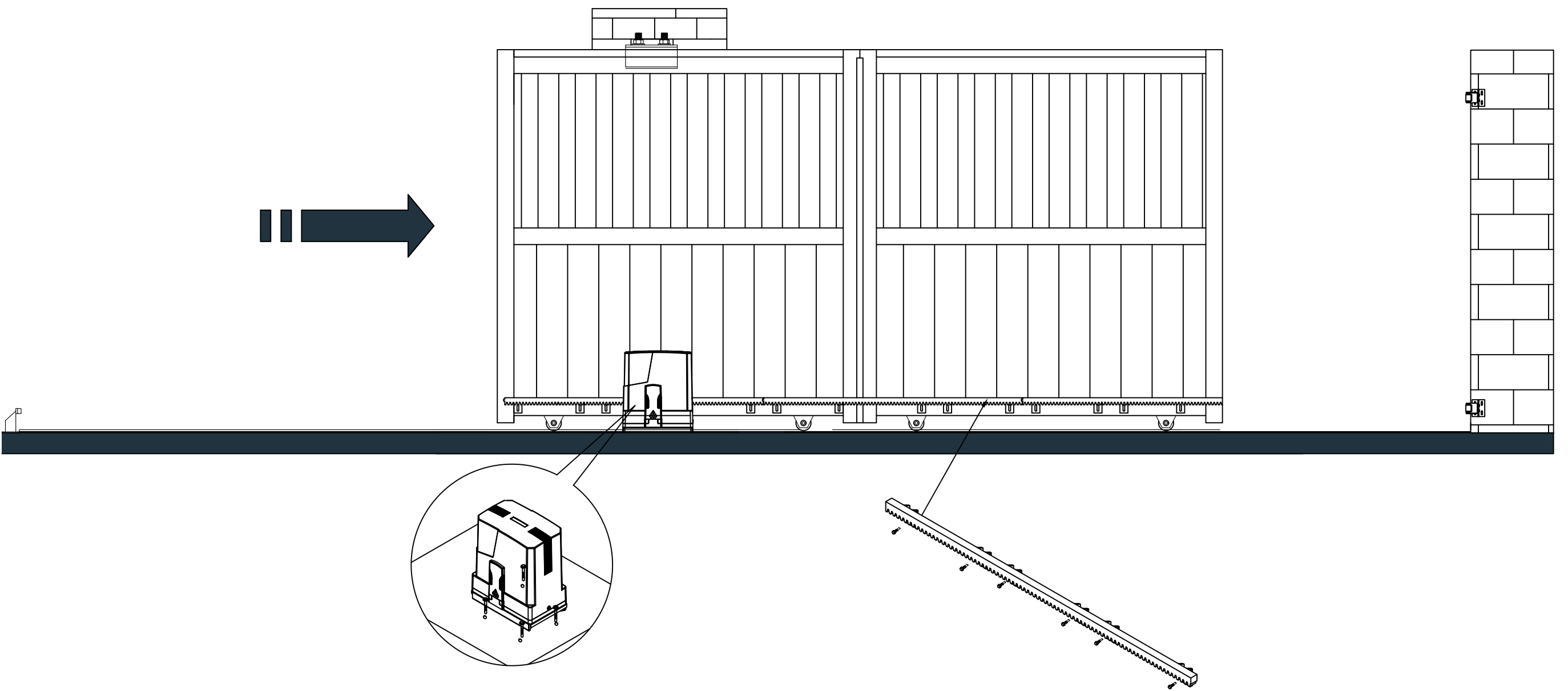
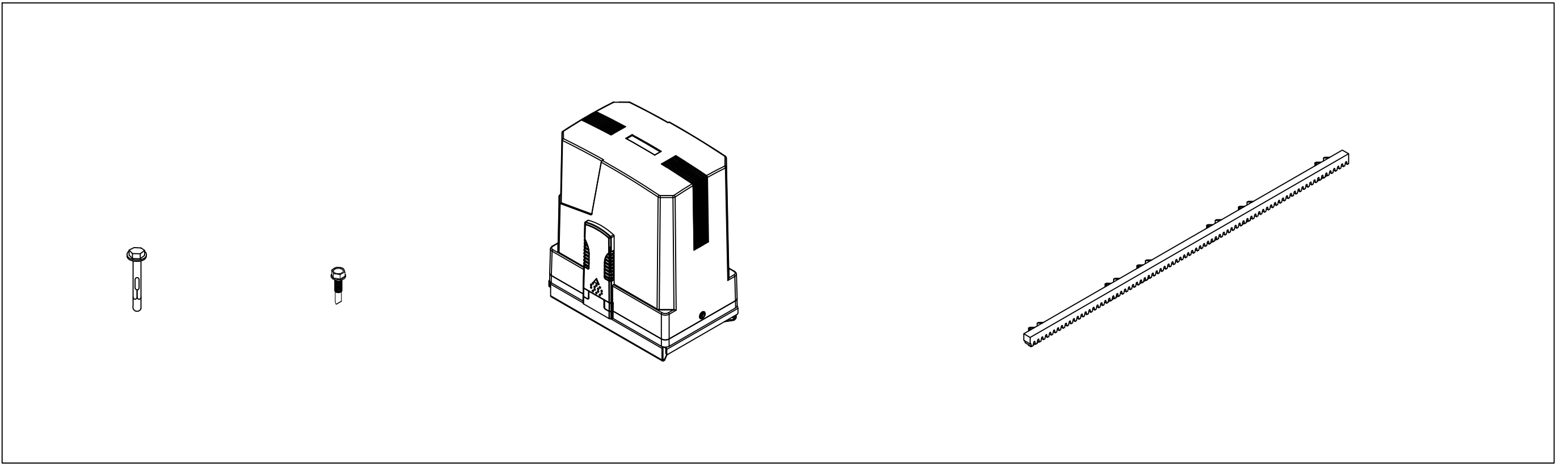



Vente-unique<sup>.com</sup>

VS-NOV-2023

Imported by - Importé par  
VENTE-UNIQUE.COM  
9 Rue Jacquart 93310 Le Pré-Saint-Gervais  
Made in China/ Fabriqué en Chine