

PORTAIL BATTANT EN ALU À MOTIFS
PATTERNED ALU SWING GATE
GEMUSTERTES ALU SCHWINGTOR
PUERTA BATIENTE DE ALU ESTAMPADA
CANCELLO A BATTENTE IN ALLUMINIO FANTASIA
PATROON ALU DRAAIPOORT
PADRÃO ALU SWING GATE
WZOROWANA BRAMA SKRZYDŁA ALUMINIOWA
TARNOS

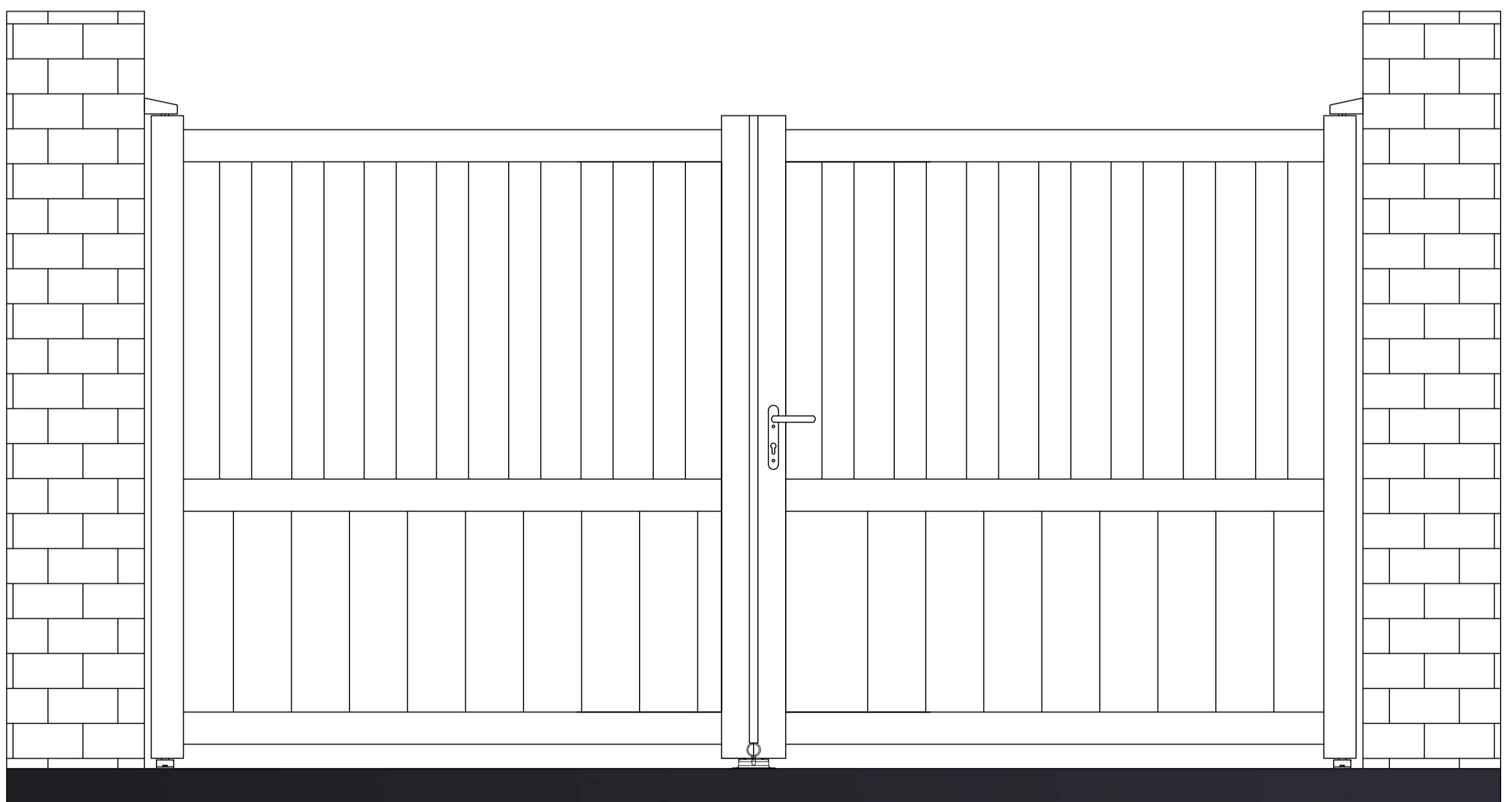

UV09-1D/UV09-2D/UV09-3D

FR

Inspectez votre porte en particulier la pièce d'usure comme les charnières supérieures et inférieures, verrouillez-la tous les 6 mois, si le produit ou le composant est endommagé, arrêtez immédiatement d'utiliser le produit et contactez notre service clientèle pour obtenir une aide professionnelle sur le produit et la maintenance.

EN

Inspect your door especially the wearing part like top and bottom hinges, lock for every 6 months, if the product or component is damaged, please stop using the product immediately and contact our customer service to get a professional help about the product and the maintenance.

DE

Überprüfen Sie Ihre Tür, insbesondere das Verschleißteil wie die oberen und unteren Scharniere, verriegeln Sie sie alle 6 Monate. Wenn das Produkt oder die Komponente beschädigt ist, stellen Sie die Verwendung des Produkts sofort ein und wenden Sie sich an unseren Kundendienst, um professionelle Hilfe zu dem Produkt und der Wartung zu erhalten.

ES

Inspeccione su puerta, especialmente la parte de desgaste, como las bisagras superior e inferior, cierre cada 6 meses, si el producto o componente está dañado, deje de usar el producto de inmediato y comuníquese con nuestro servicio al cliente para obtener ayuda profesional sobre el producto y el mantenimiento.

IT

Ispeziona la tua porta, in particolare la parte soggetta a usura come le cerniere superiore e inferiore, bloccala ogni 6 mesi, se il prodotto o il componente è danneggiato, interrompi immediatamente l'uso del prodotto e contatta il nostro servizio clienti per ottenere un aiuto professionale sul prodotto e sulla manutenzione.

NL



Inspecteer uw deur, met name het slijtende deel zoals de scharnieren aan de boven- en onderkant, sluit elke 6 maanden, als het product of onderdeel beschadigd is, stop dan onmiddellijk met het gebruik van het product en neem contact op met onze klantenservice voor professionele hulp over het product en het onderhoud.





PT

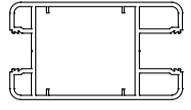
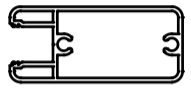
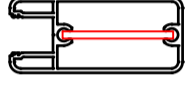
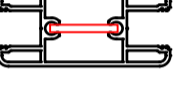
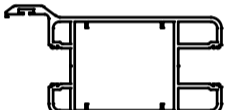
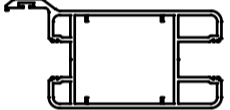

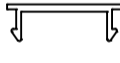
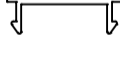
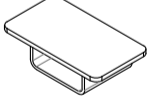
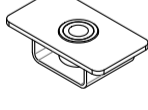
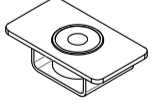
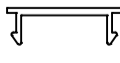
Inspecione suas portas especialmente o desgaste como dobradiças superior e inferior, feche a cada 6 meses, se o produto ou componente estiver danificado, pare de usar o produto imediatamente e entre em contato com nosso serviço de atendimento ao cliente para obter ajuda profissional sobre o produto e a manutenção.

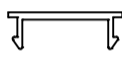

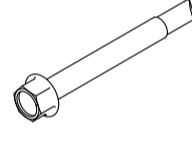
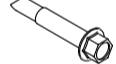
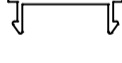

PL

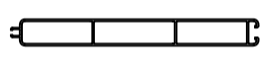
Sprawdź swoje drzwi, zwłaszcza części zużywające się, takie jak górne i dolne zawiasy, zablokuj co 6 miesięcy, jeśli produkt lub element jest uszkodzony, natychmiast przestań używać produktu i skontaktuj się z naszym działem obsługi klienta, aby uzyskać profesjonalną pomoc dotyczącą produktu i konserwacji.

| BOX 1/3 | | | | |
|---------|---|-----------|-----------|-----------|
| NO. | Section | UV09-1D | UV09-2D | UV09-3D |
| | | QTY (pcs) | QTY (pcs) | QTY (pcs) |
| 1 |  | 2 | 2 | 2 |
| 2 |  | 2 | 2 | 2 |
| 22 |  | 2 | 2 | 2 |
| 3 |  | 2 | 2 | 2 |
| 9 |  | 1 | 1 | 1 |
| 19 |  | 1 | 1 | 1 |
| 4 |  | 4 | 4 | 4 |
| 7 |  | 8 | 8 | 8 |
| 8 |  | 24+2 | 28+2 | 36+2 |
| 10 |  | 4 | 4 | 4 |
| 11 |  | 2 | 2 | 2 |
| 12 |  | 2 | 2 | 2 |
| 13 |  | 8 | 8 | 8 |

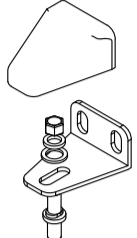
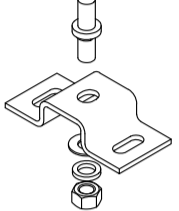
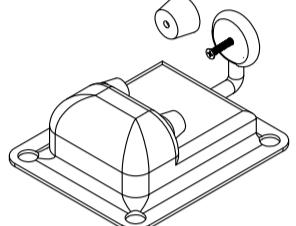
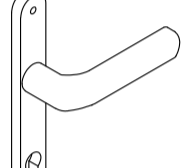
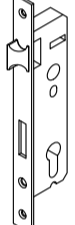
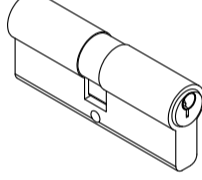
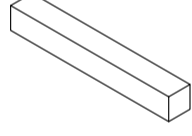
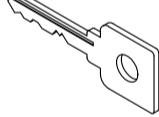
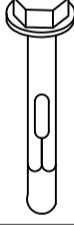
| BOX 1/3 | | |
|---------|---|-----------|
| NO. | Section | QTY (pcs) |
| 14 |  | 2 |
| 15 |  | 1 |
| 16 |  | 1 |
| 17 |  M6. 3*75 | 24 |
| 18 |  M4*16 | 8 |
| 20 |  | 1 |
| 21 |  | 1 |

| BOX 2/3 | | | | |
|---------|---|-----------|-----------|-----------|
| NO. | Section | UV09-1D | UV09-2D | UV09-3D |
| | | QTY (pcs) | QTY (pcs) | QTY (pcs) |
| 5 |  | 20 | 22 | 26 |
| 6 |  | 14 | 16 | 20 |

| BOX 3/3 | | |
|---------|---|-----------|
| NO. | Section | QTY (pcs) |
| 31 |  | 2 |
| 32 |  | 2 |
| 33 |  | 1 |
| 34 |  | 2 |
| 35 |  | 1 |
| 36 |  | 1 |
| 37 |  | 1 |
| 38 |  | 3 |
| 40 |  | 12 |
| 41 |  | 2 |
| 42 |  | 1 |
| 43 |  | 5 |
| 44 |  | 1 |

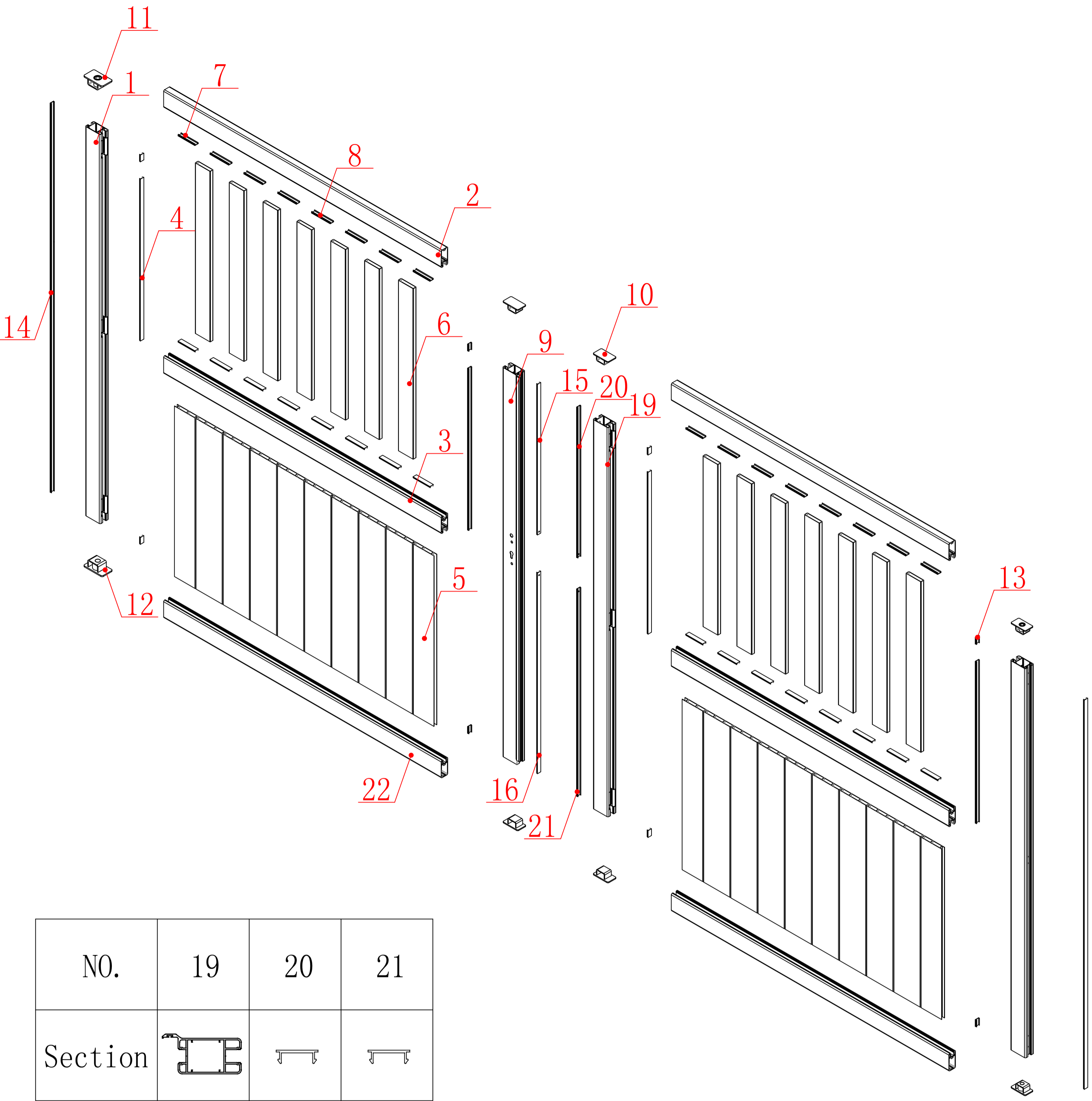

| | | | |
|---------|----|----|----|
| NO. | 19 | 20 | 21 |
| Section | | | |

| | | | | | | | | | | |
|---------|---|---|----|---|---|---|---|---|---|---|
| NO. | 1 | 2 | 22 | 3 | 4 | 5 | 6 | 7 | 8 | 9 |
| Section | | | | | | | | | | |

| | | | | | | | | | |
|---------|----|----|----|----|----|----|----|----------|-------|
| NO. | 10 | 11 | 12 | 13 | 14 | 15 | 16 | 17 | 18 |
| Section | | | | | | | | | |
| | | | | | | | | M6. 3*75 | M4*16 |

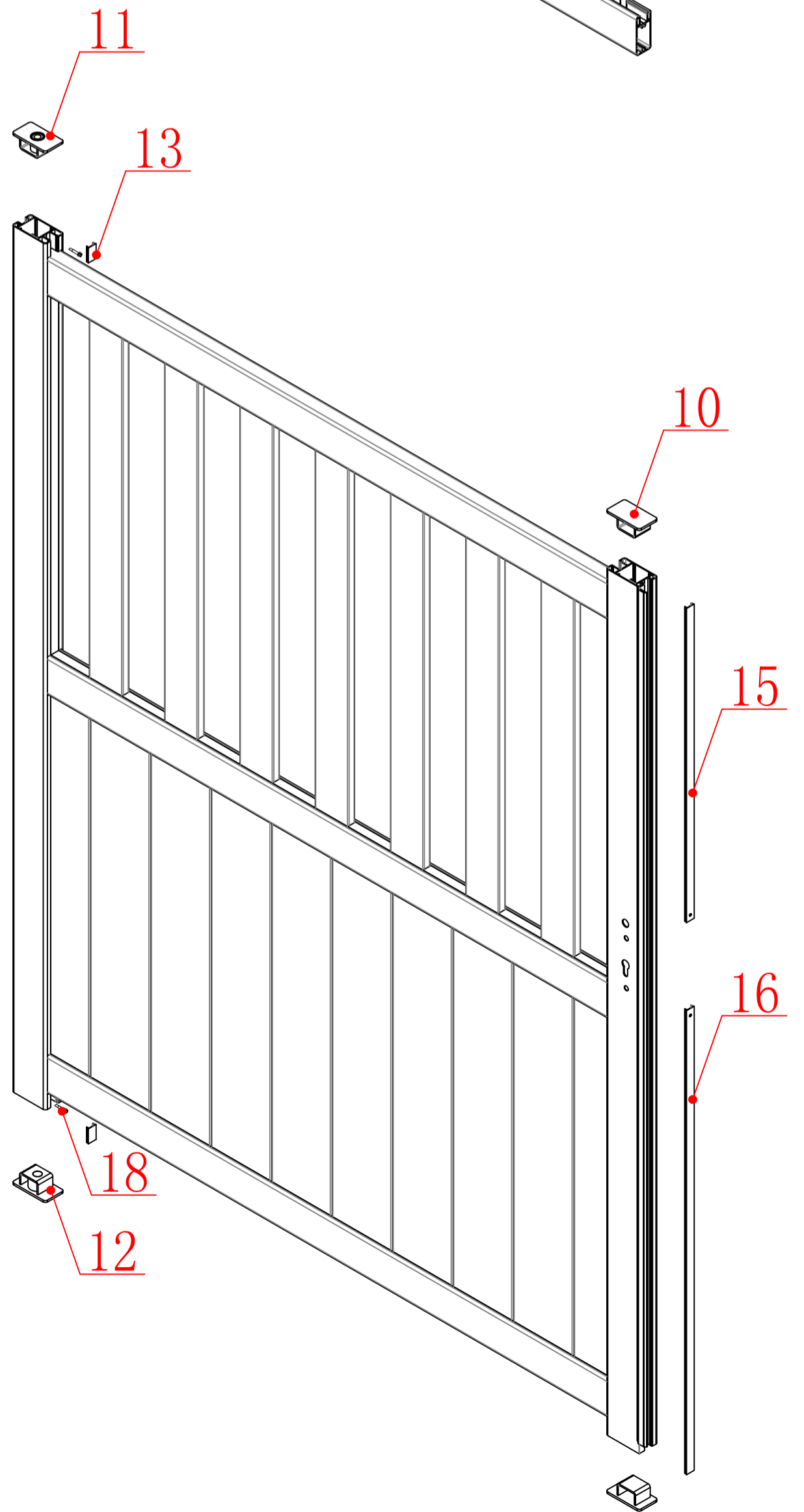
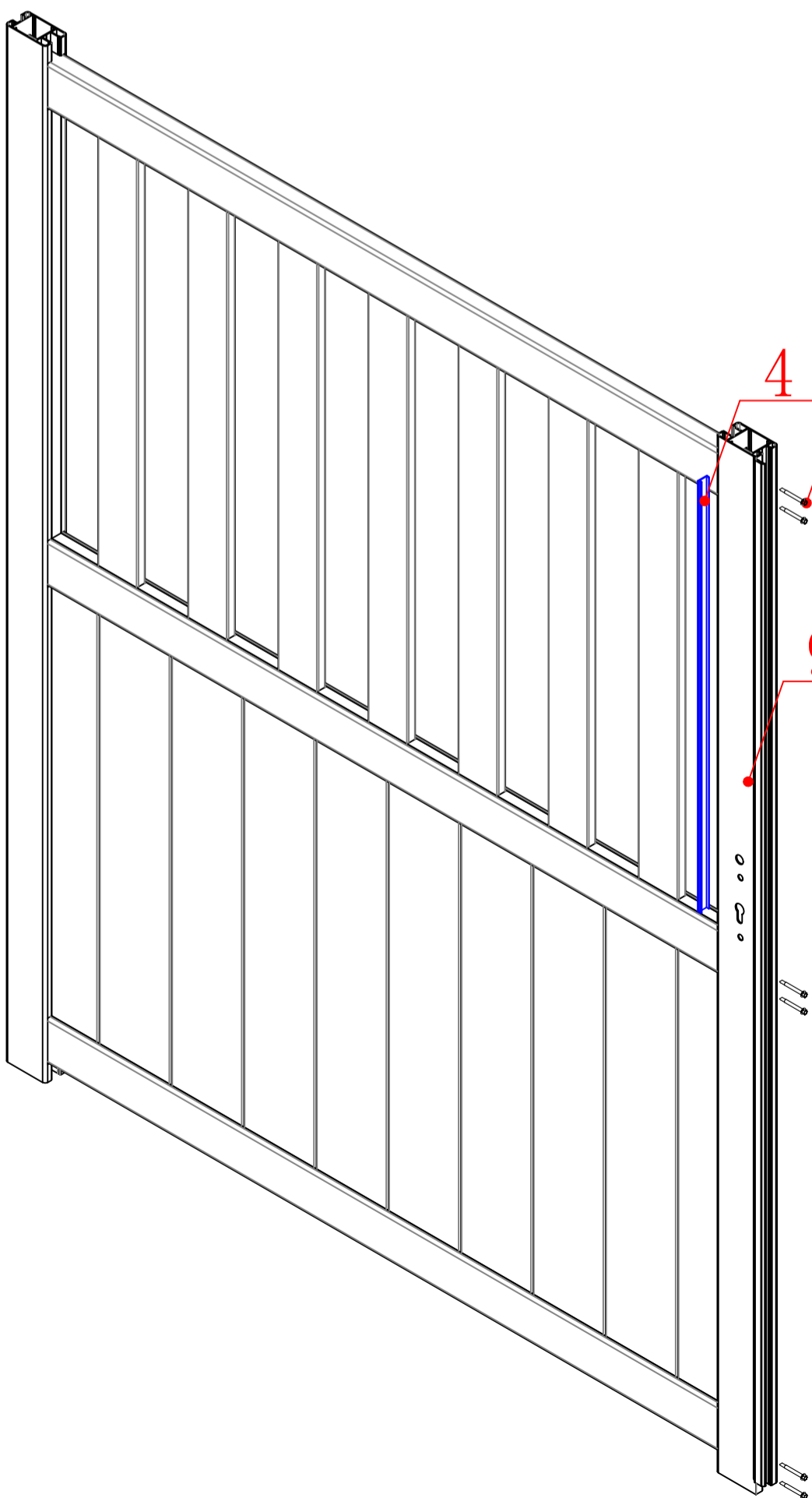
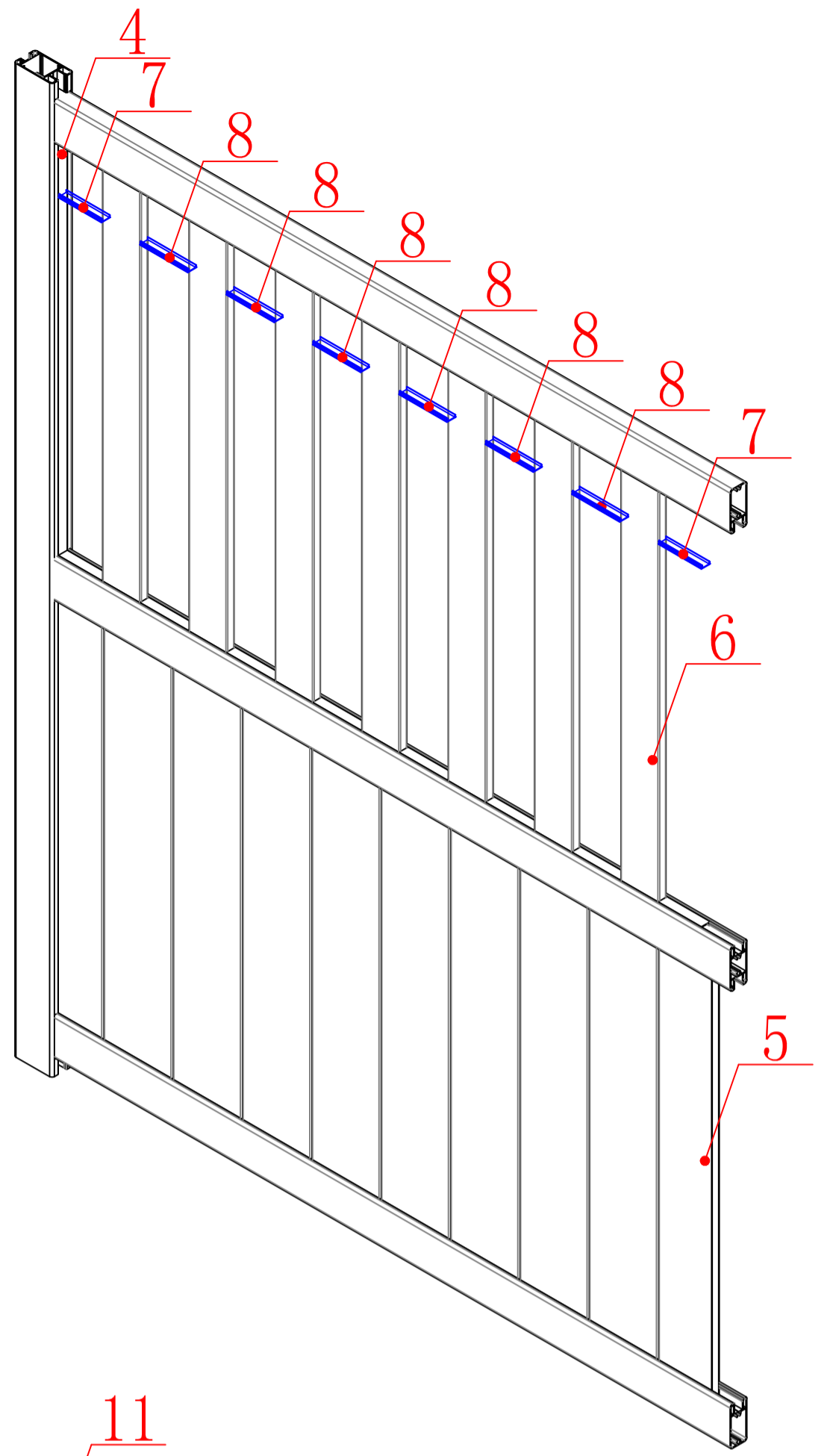
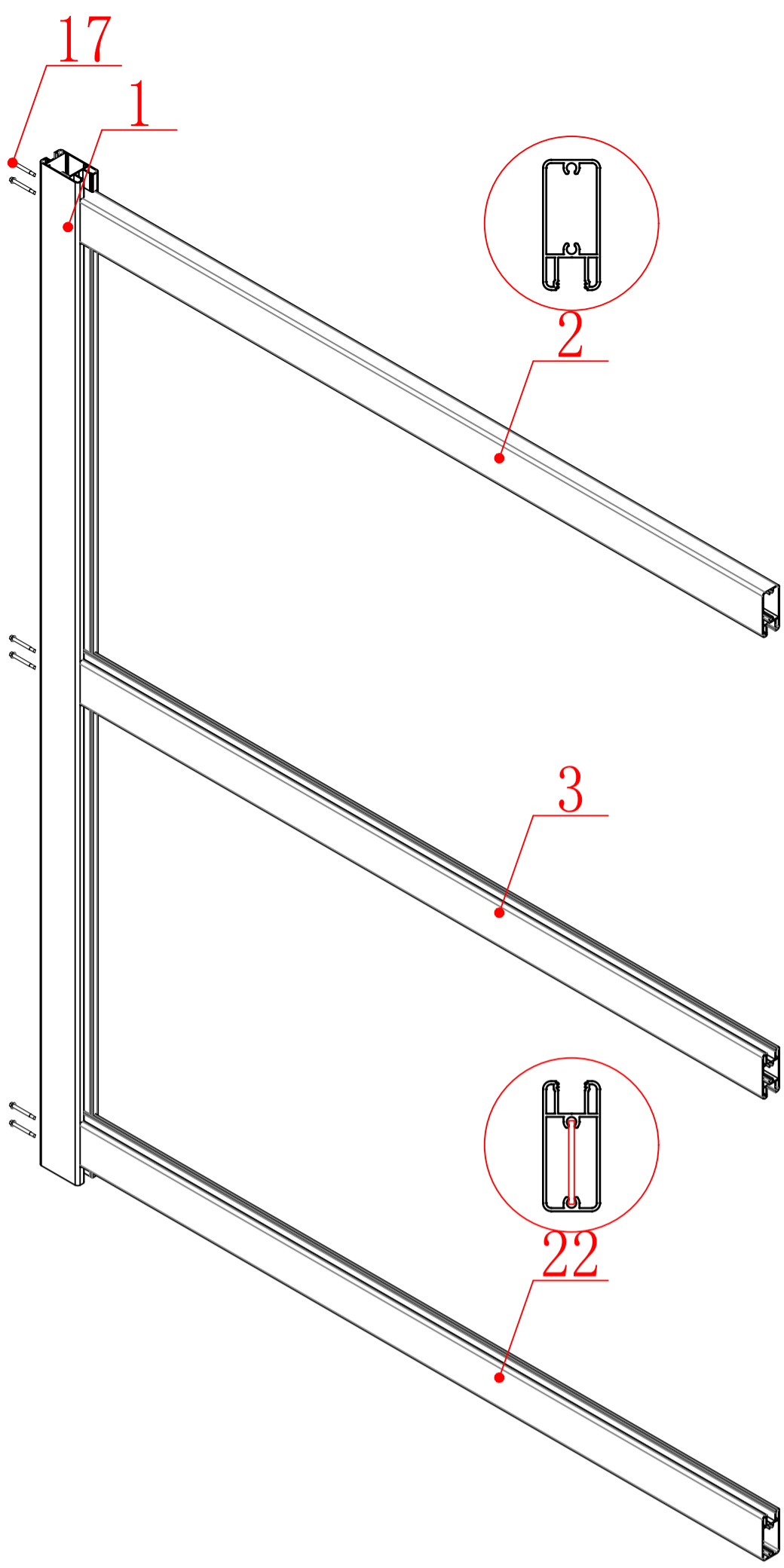

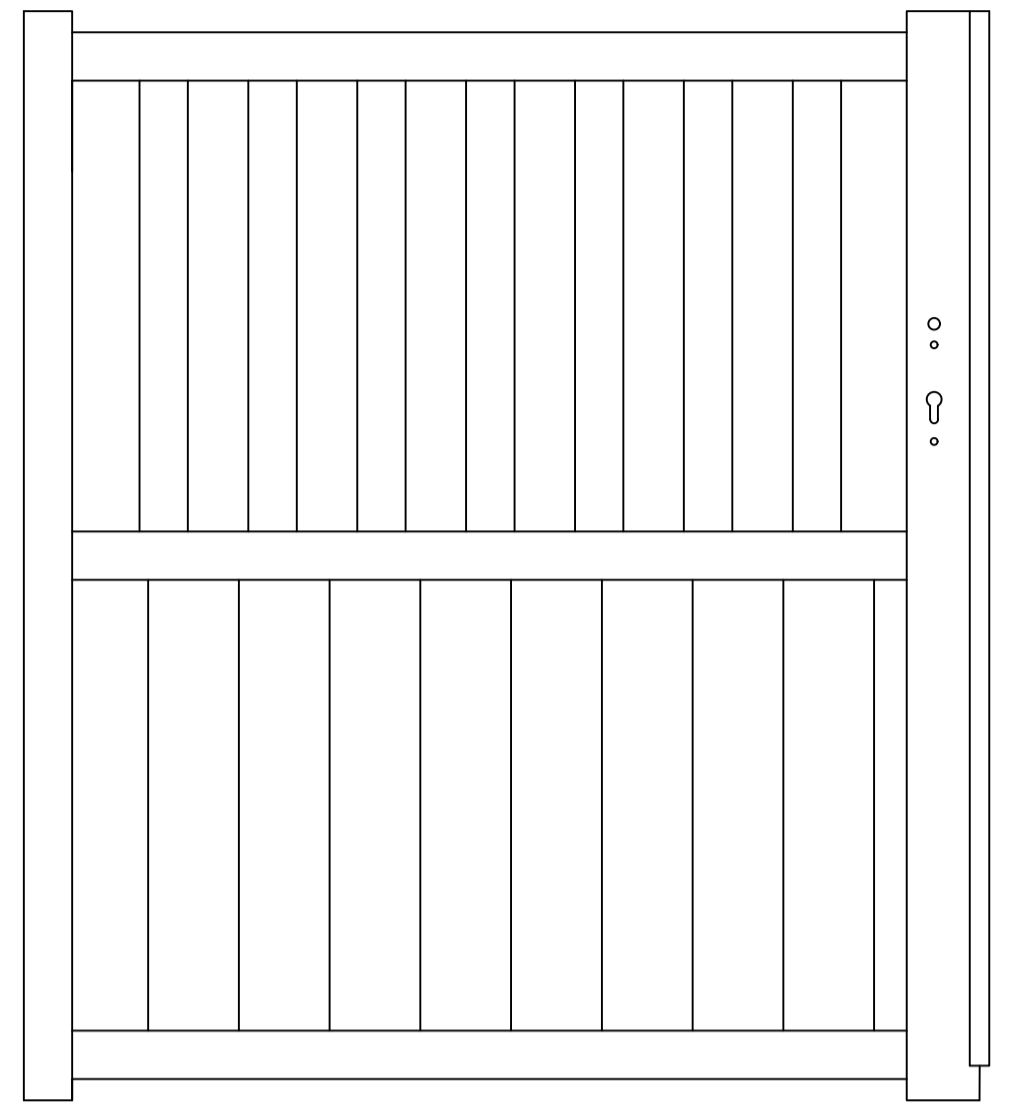
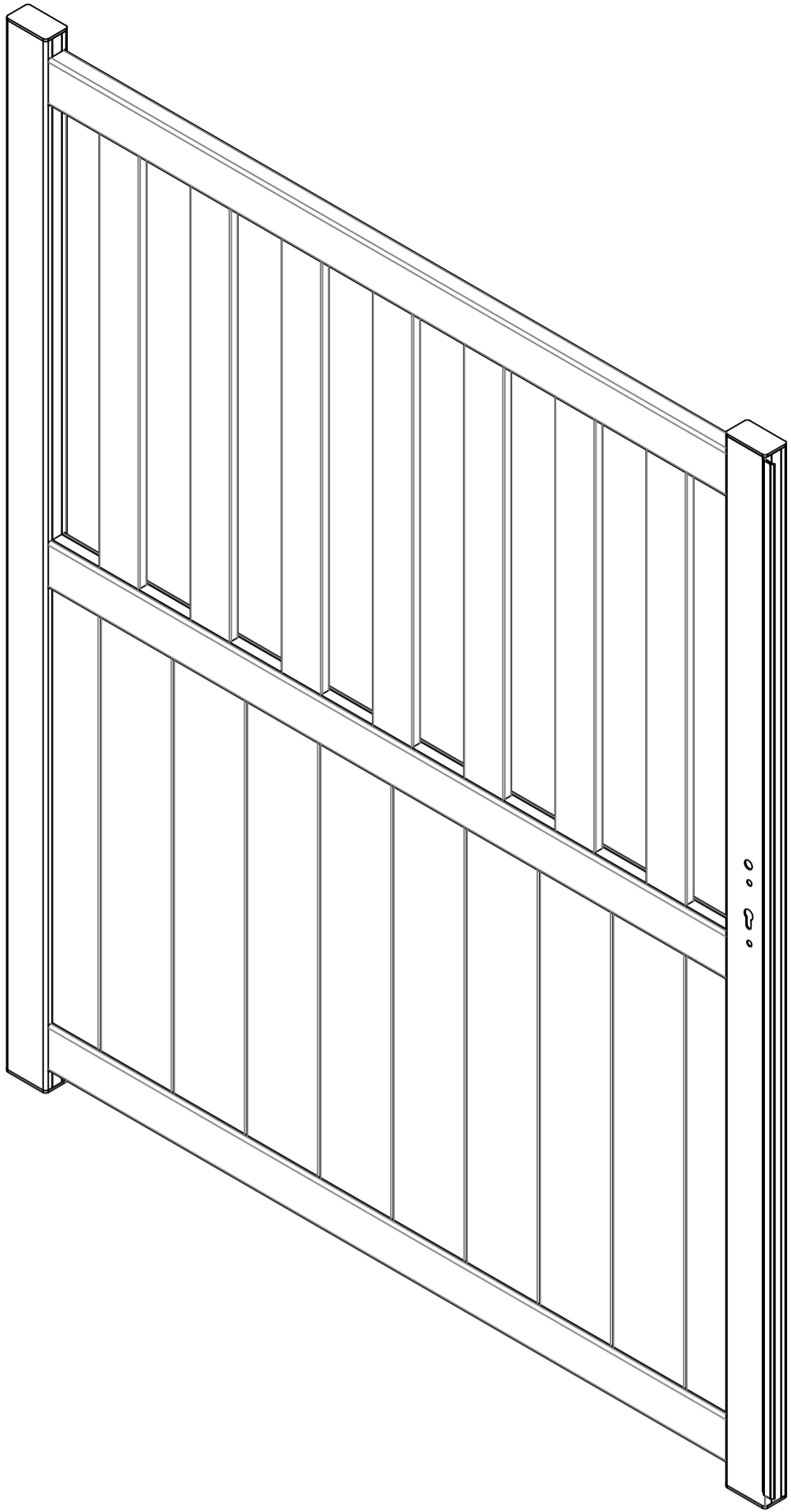

[B]

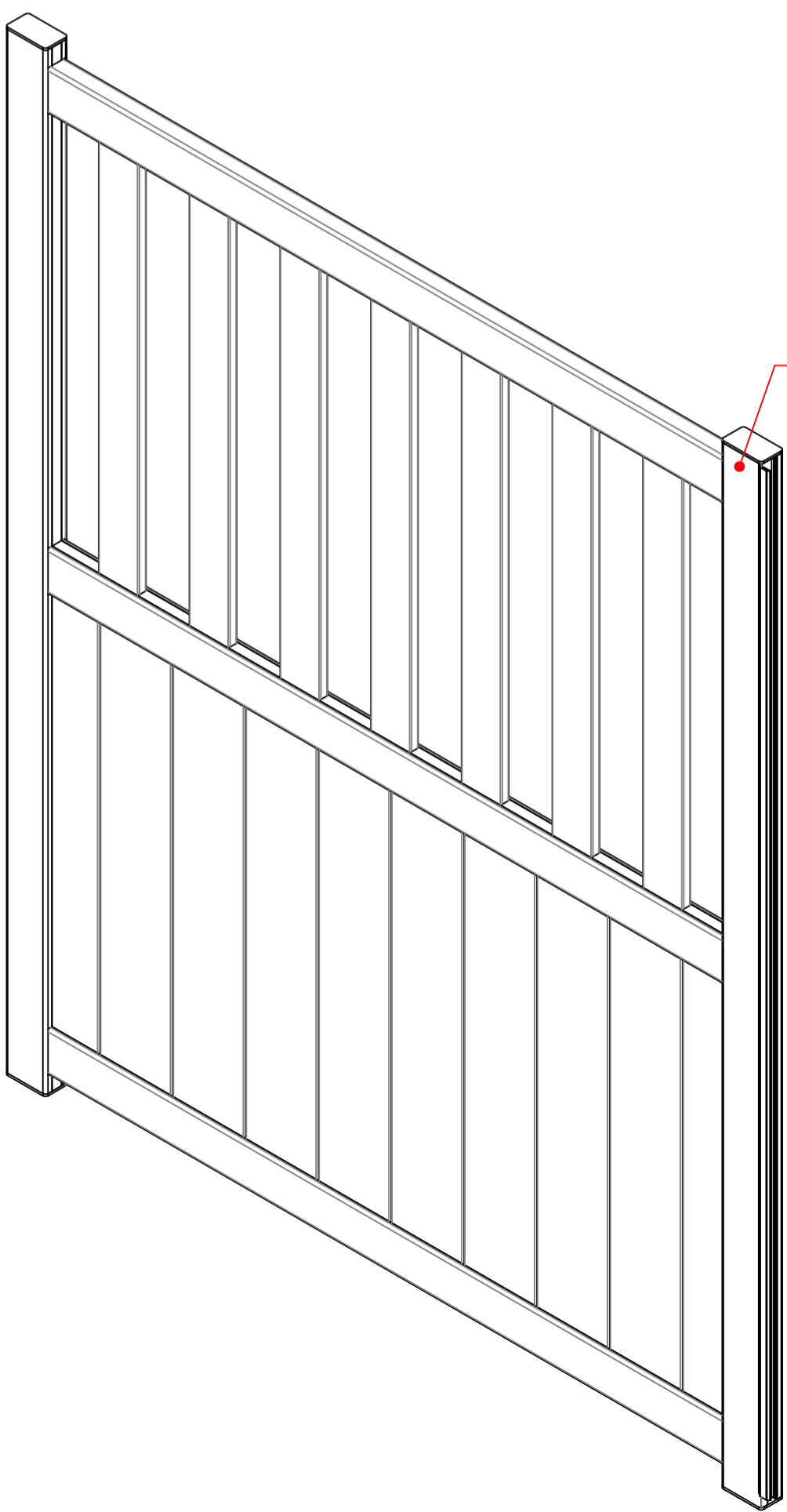

19

20

21

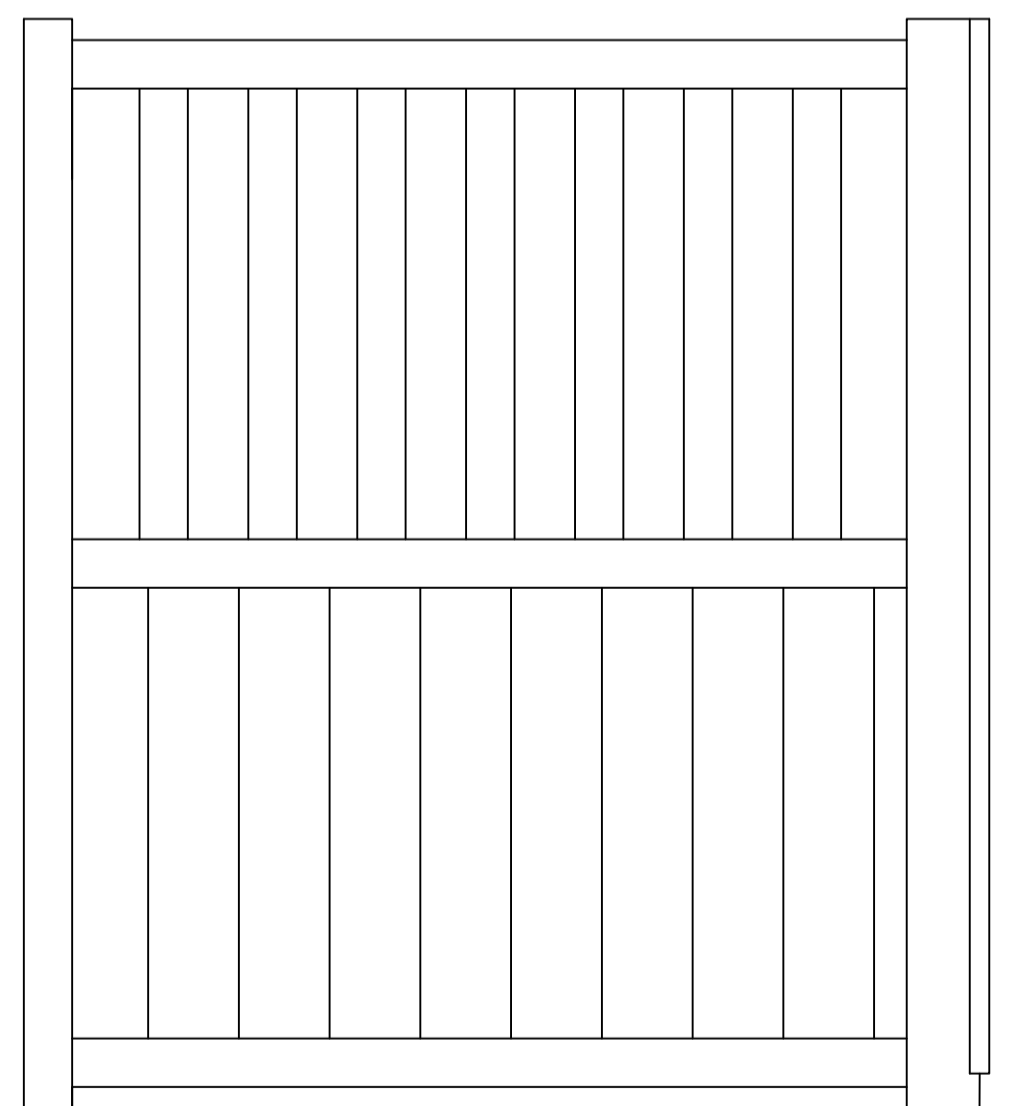

[A]

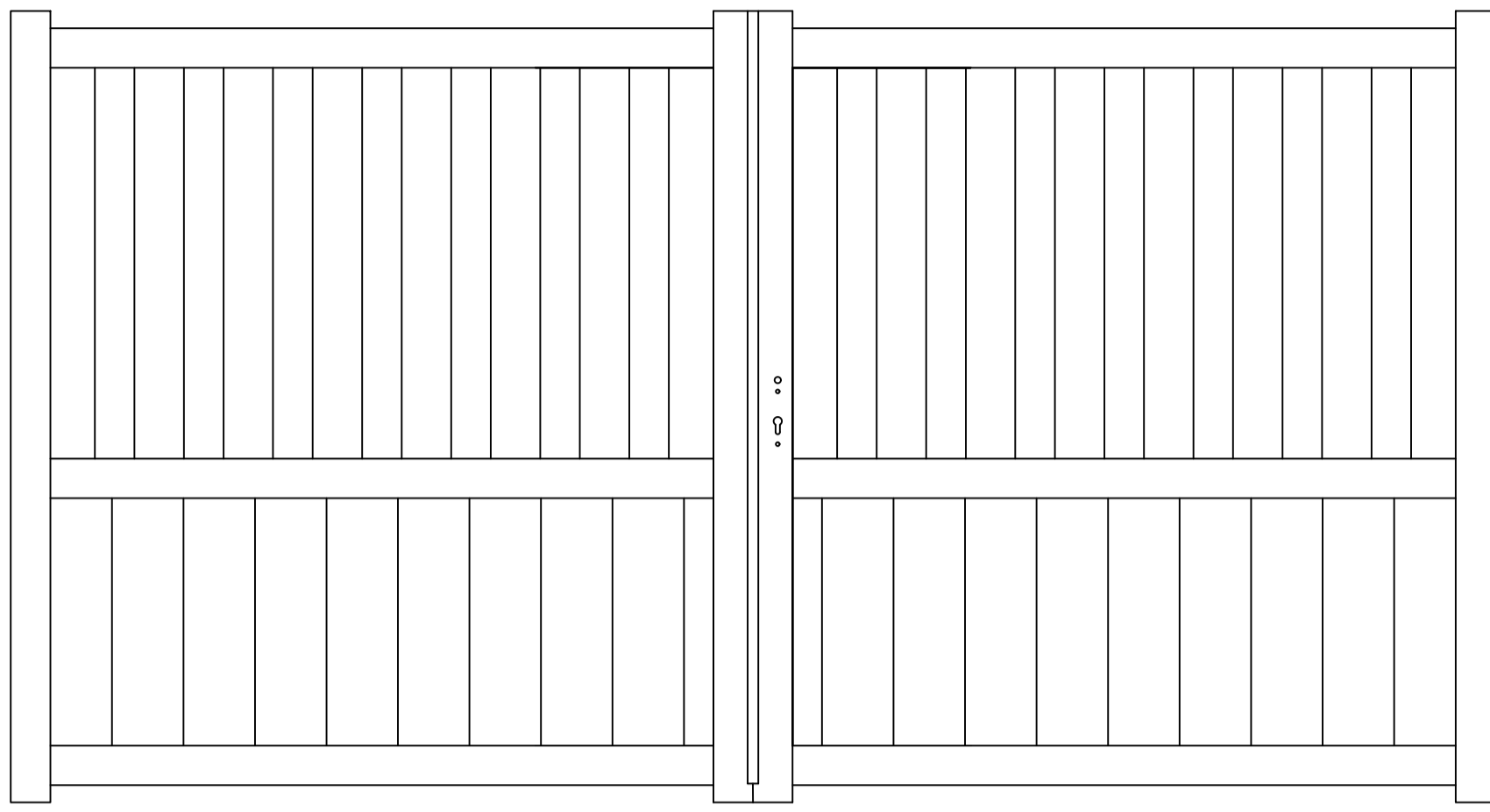

[A]*1

[B]*1

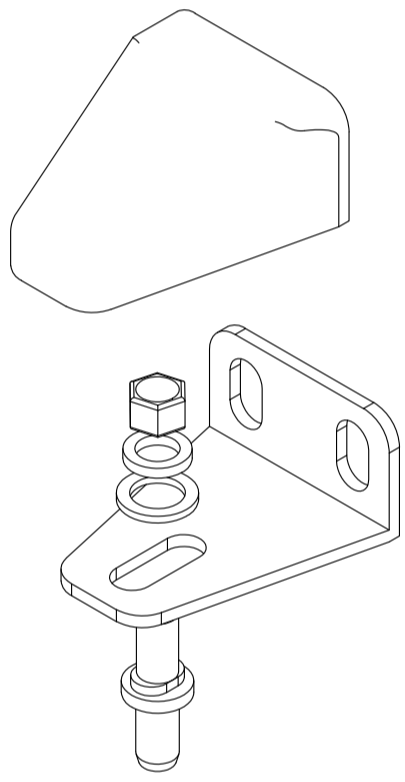

31*2

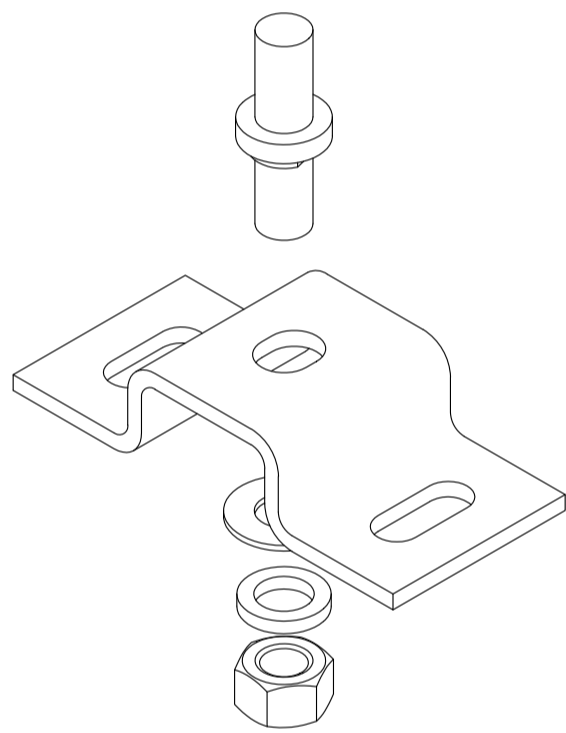

32*2

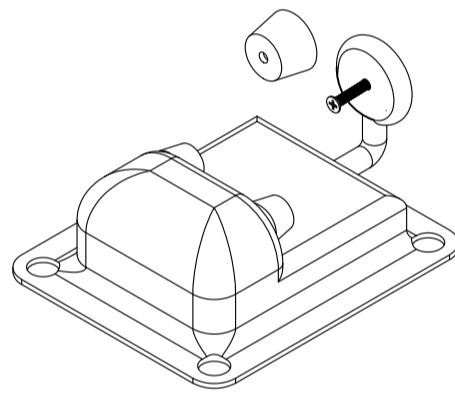

33*1

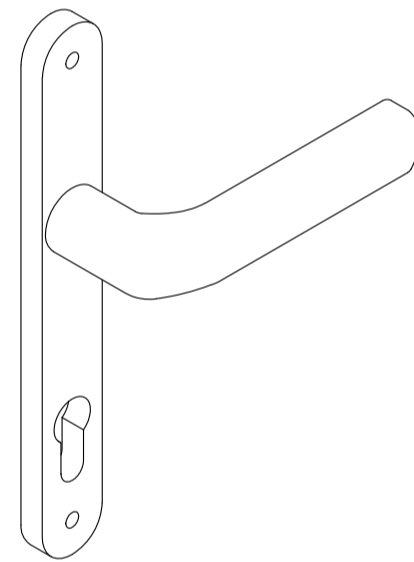

34*2

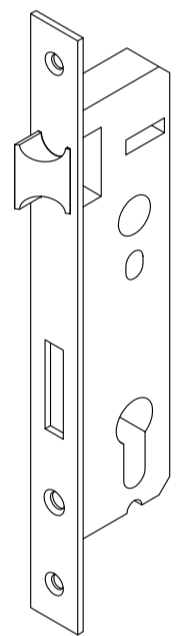

35*1

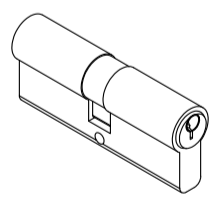

36*1

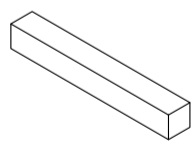

37*1

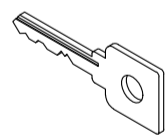

38*3



40*12



41*2



42*1



43*5



44*1

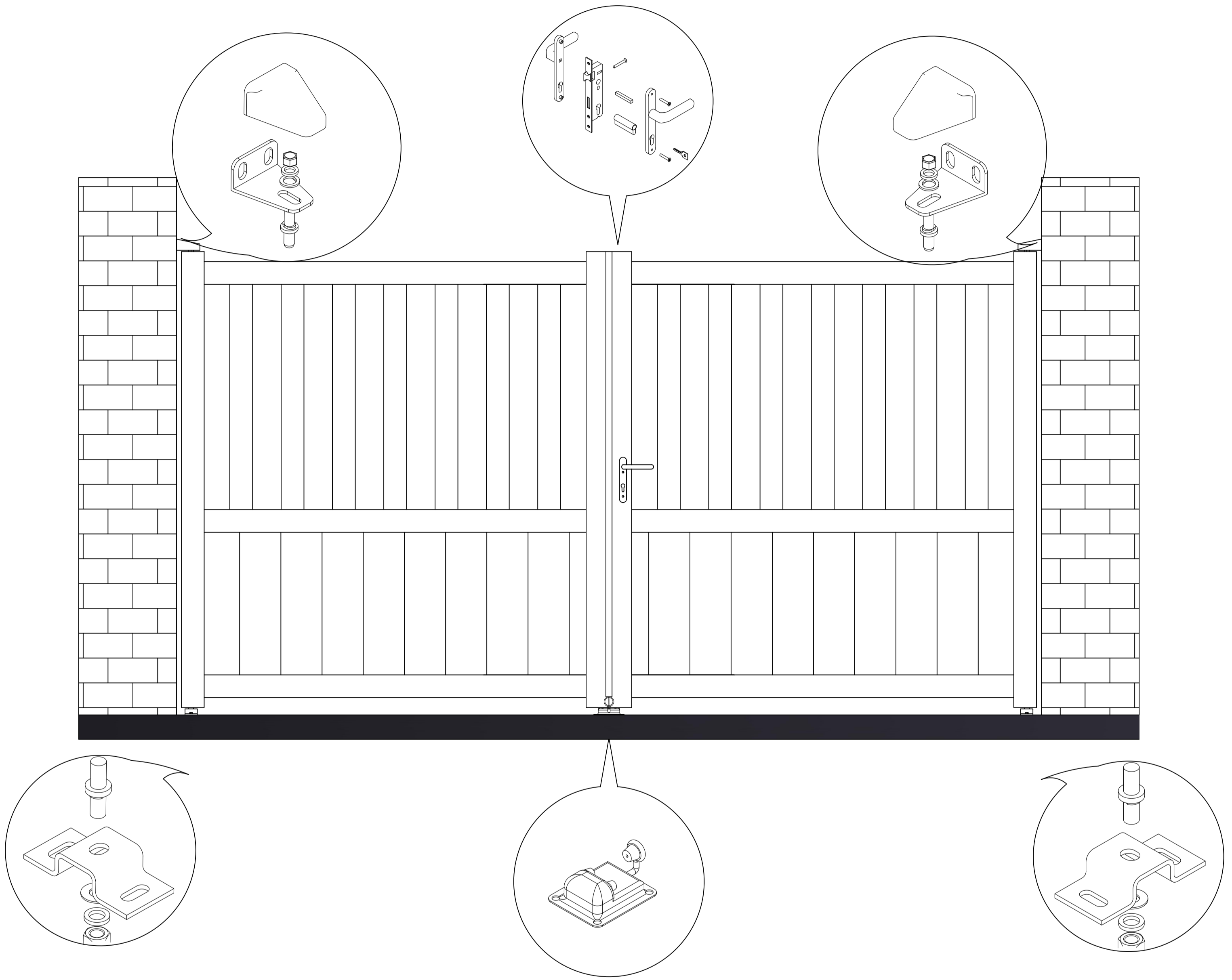

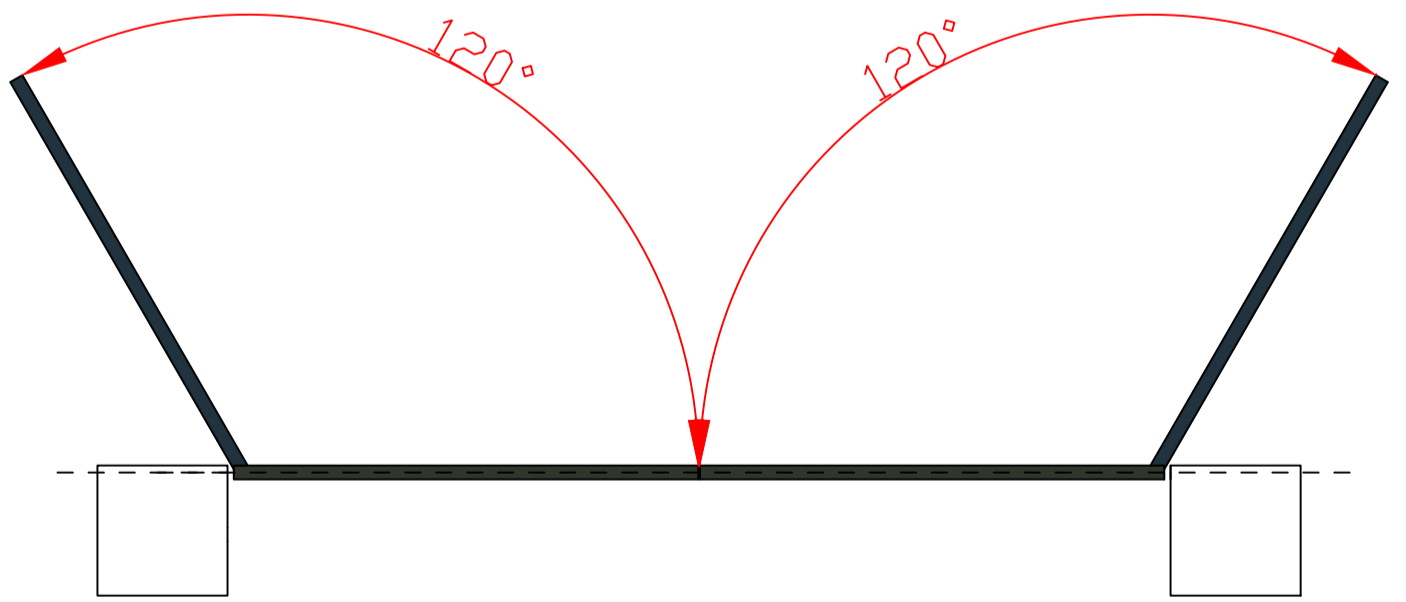
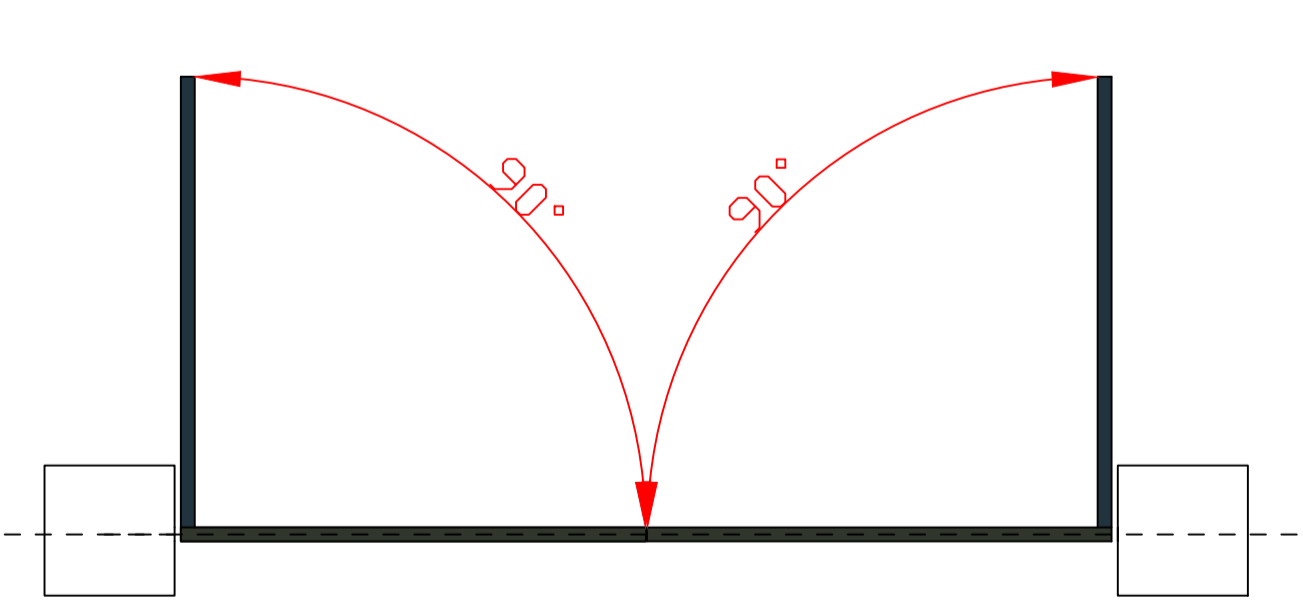
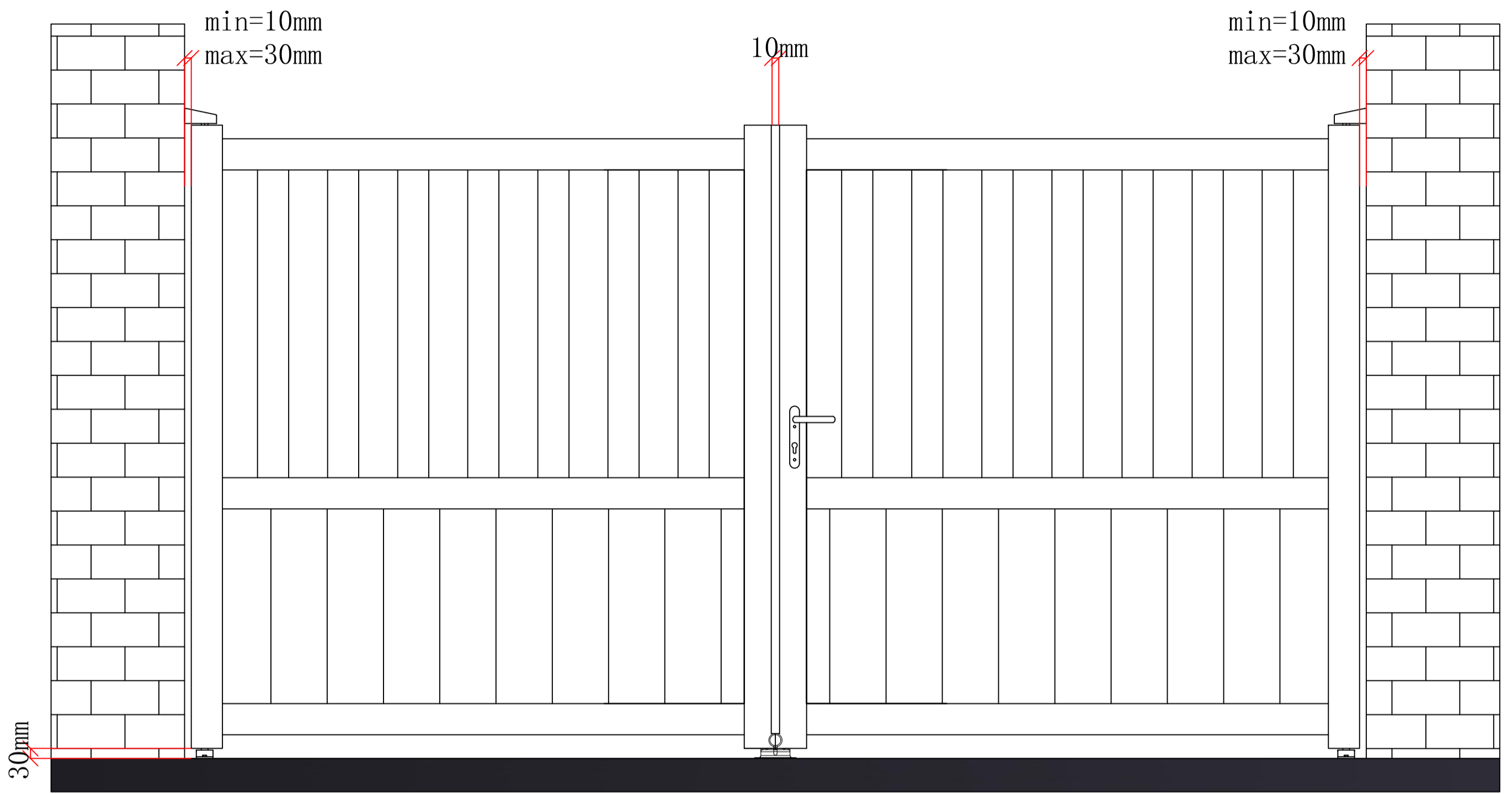

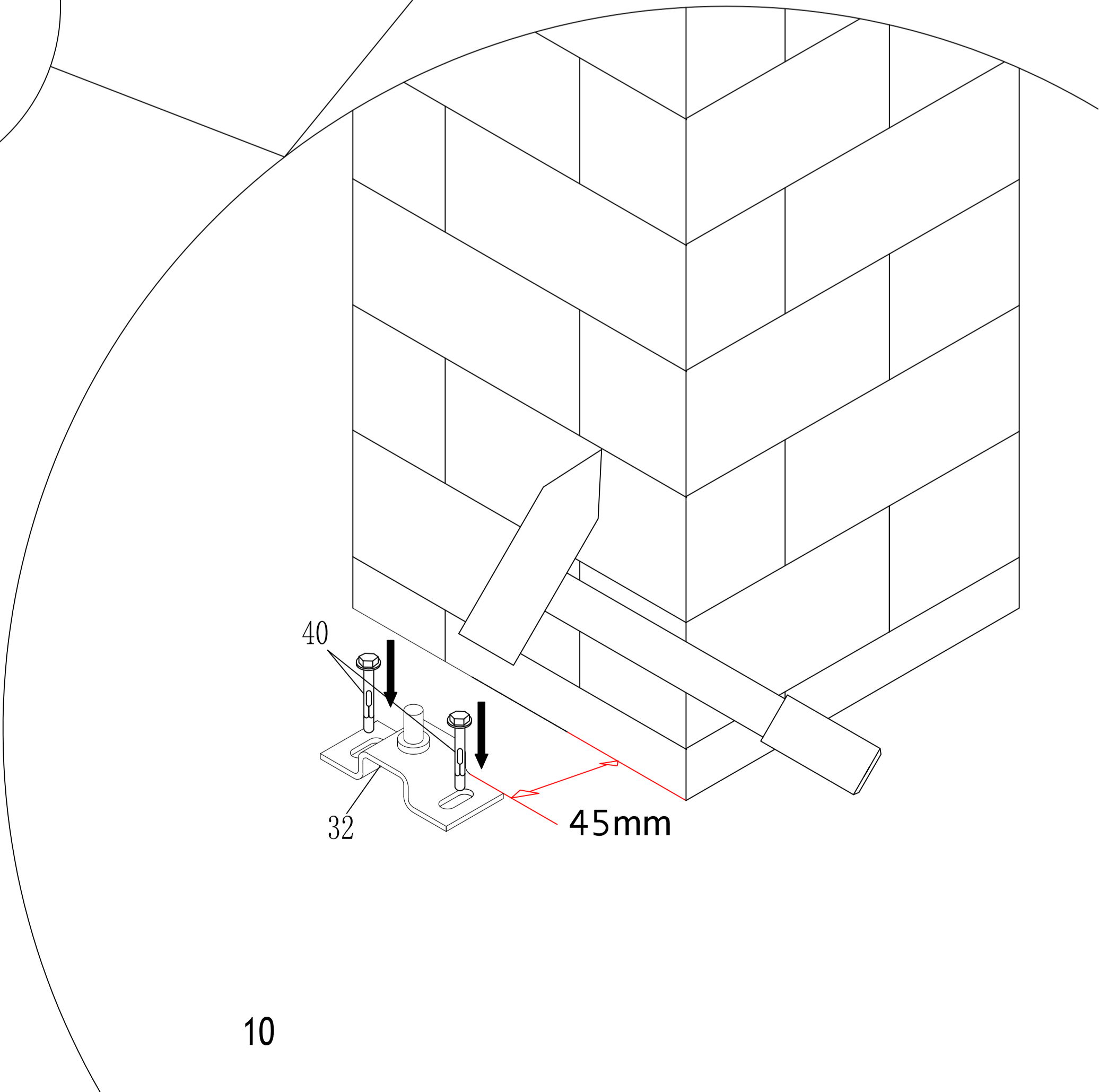
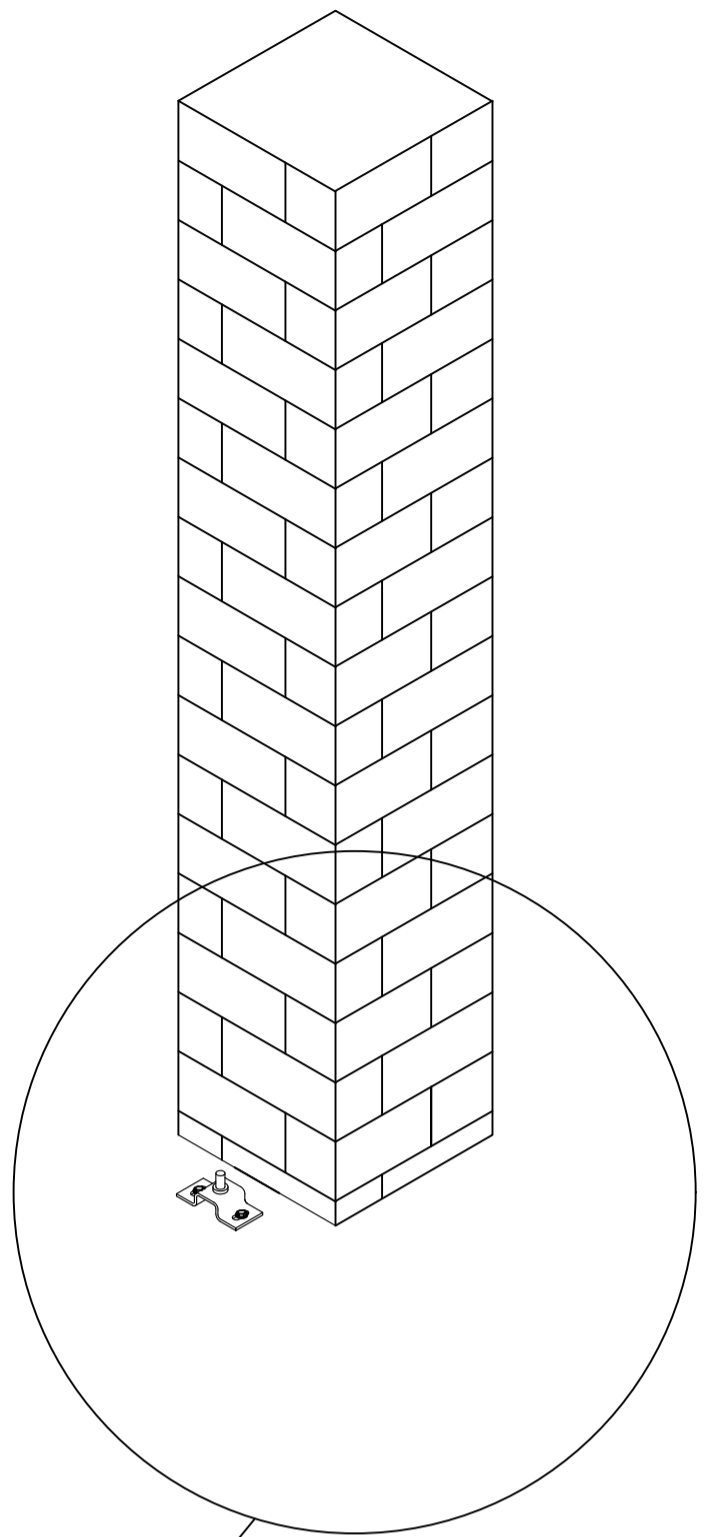
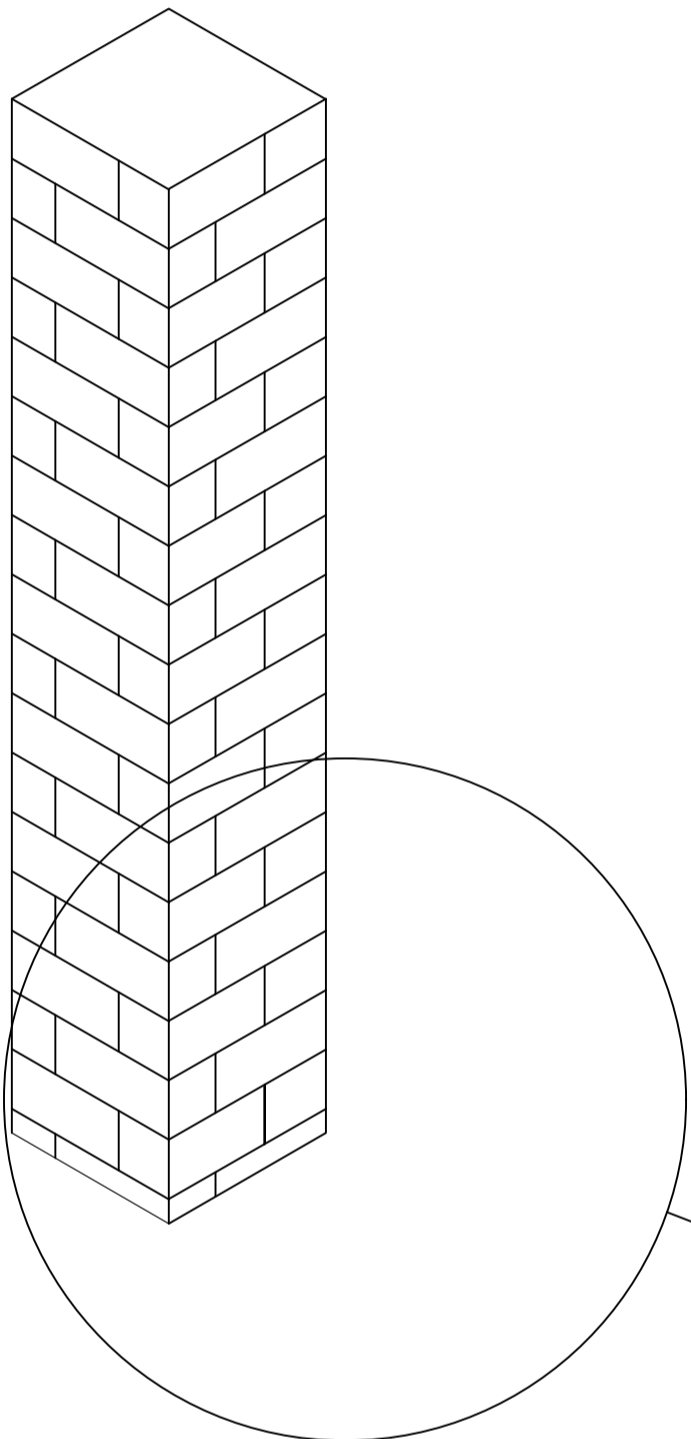
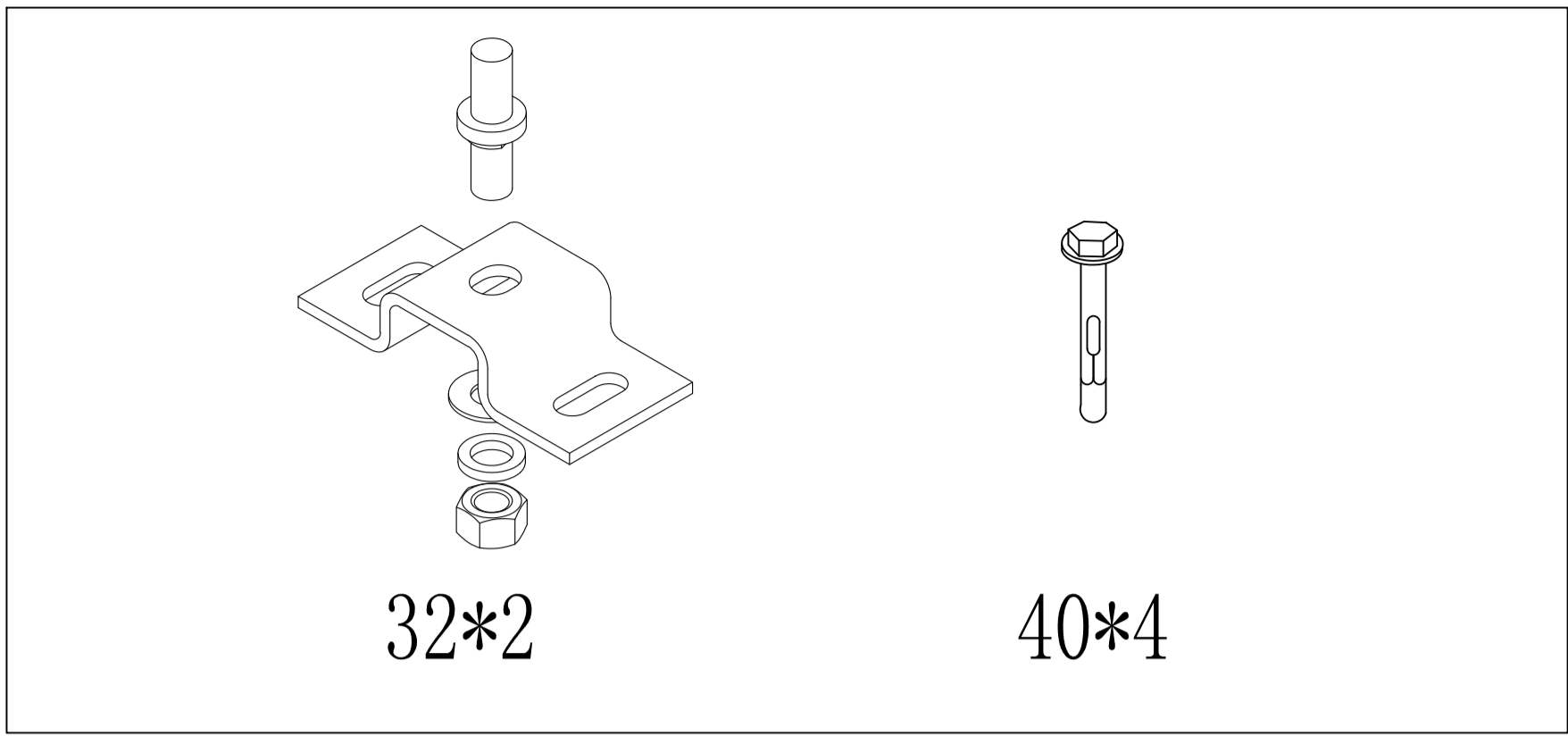

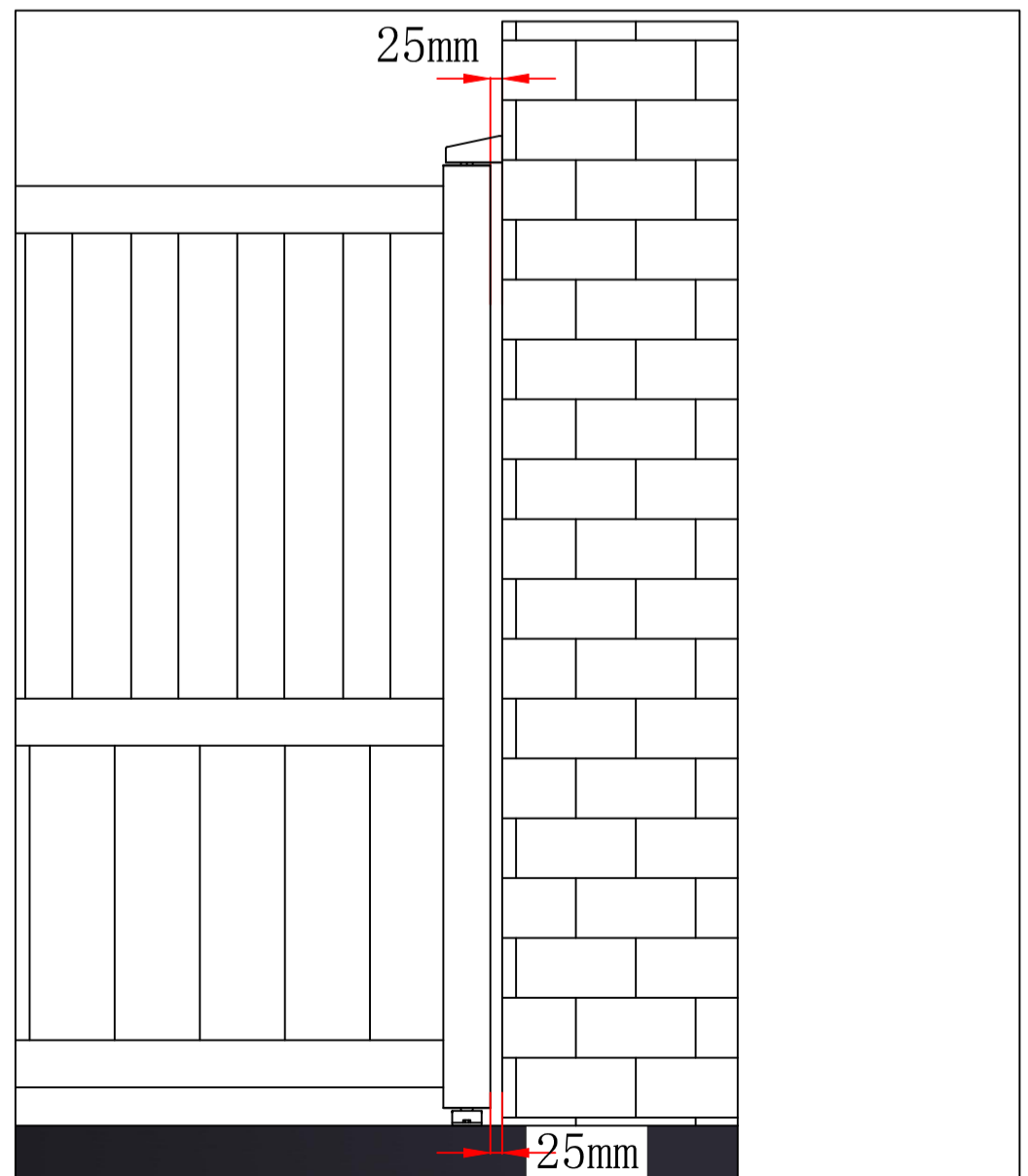
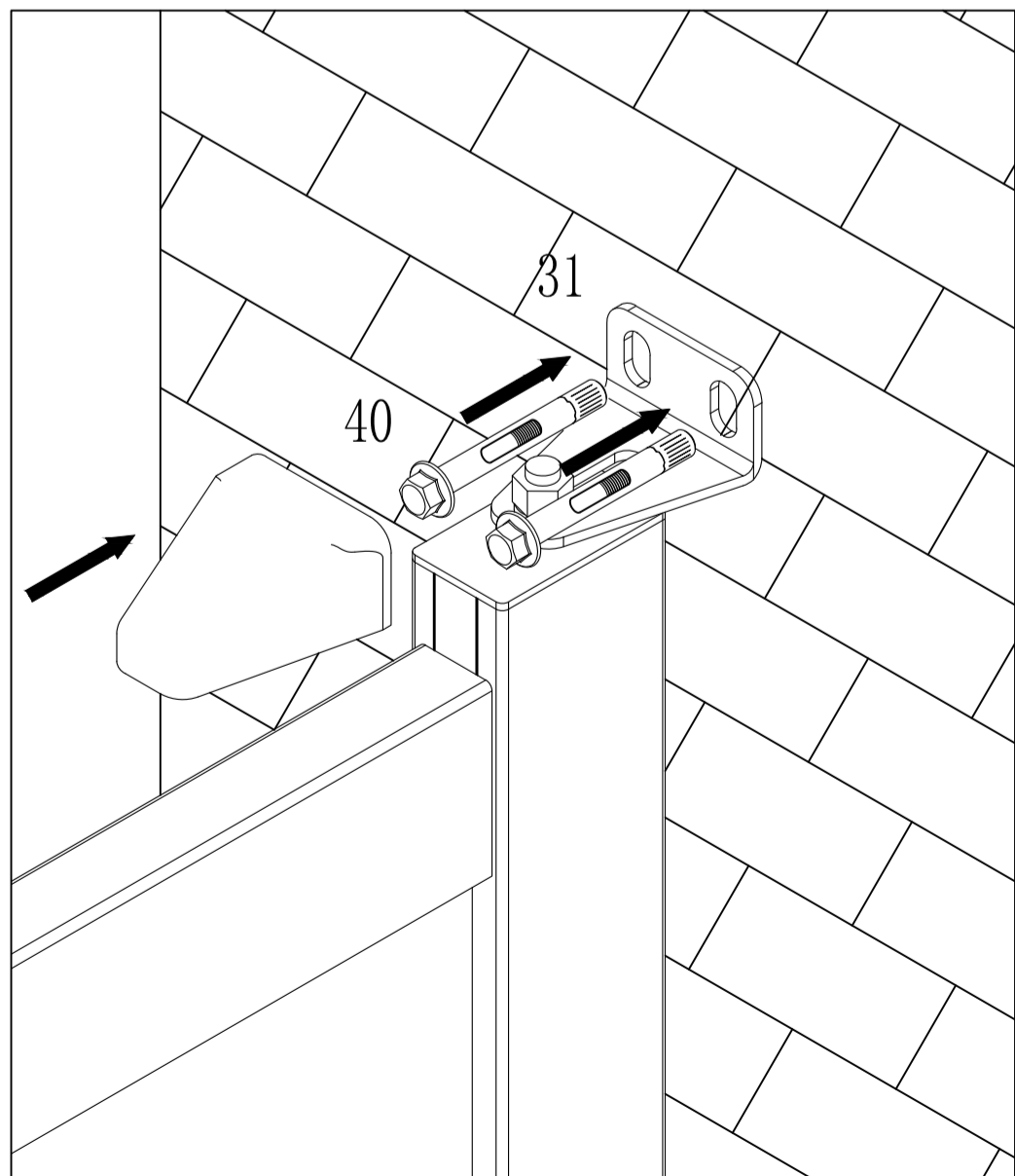
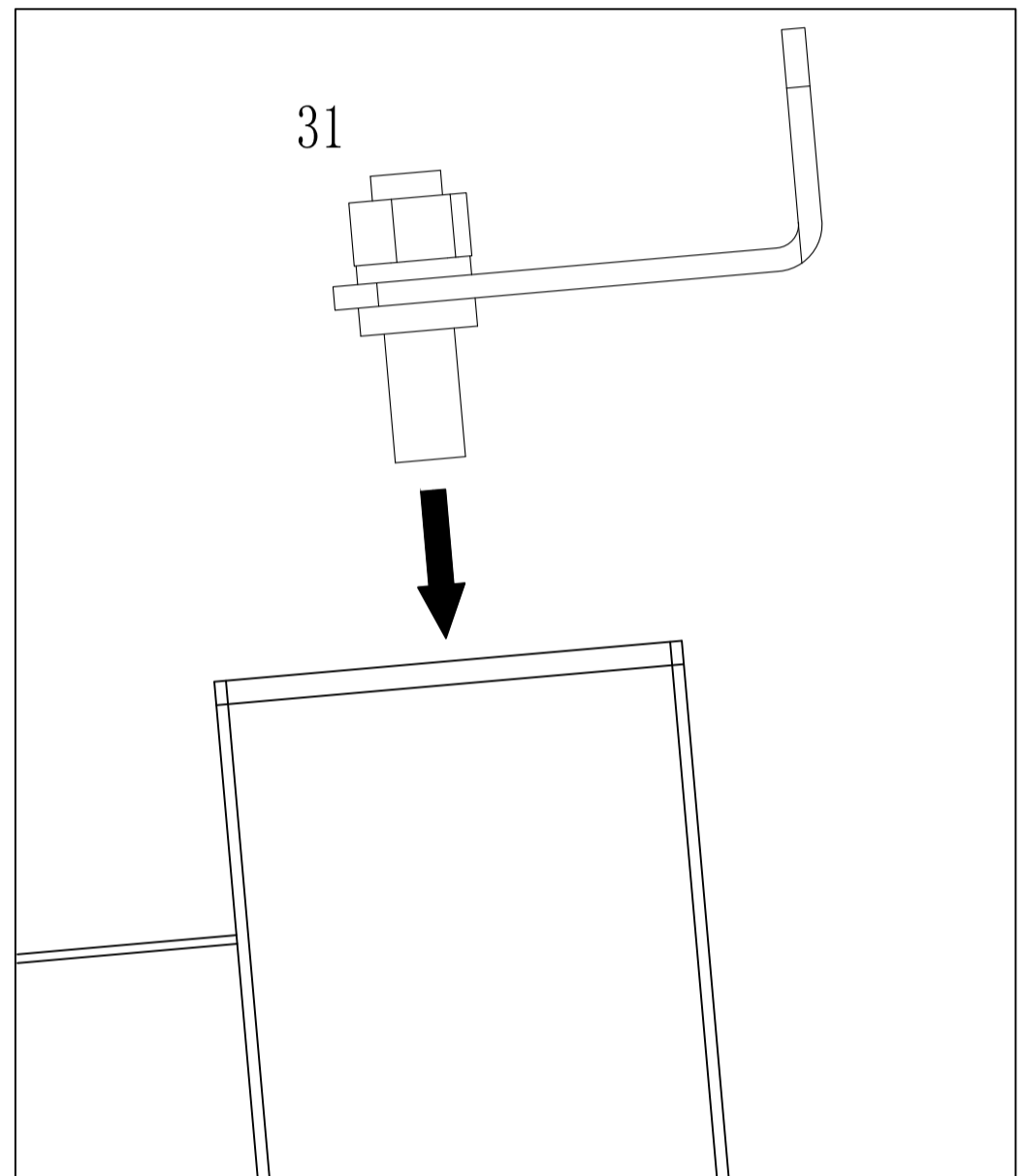
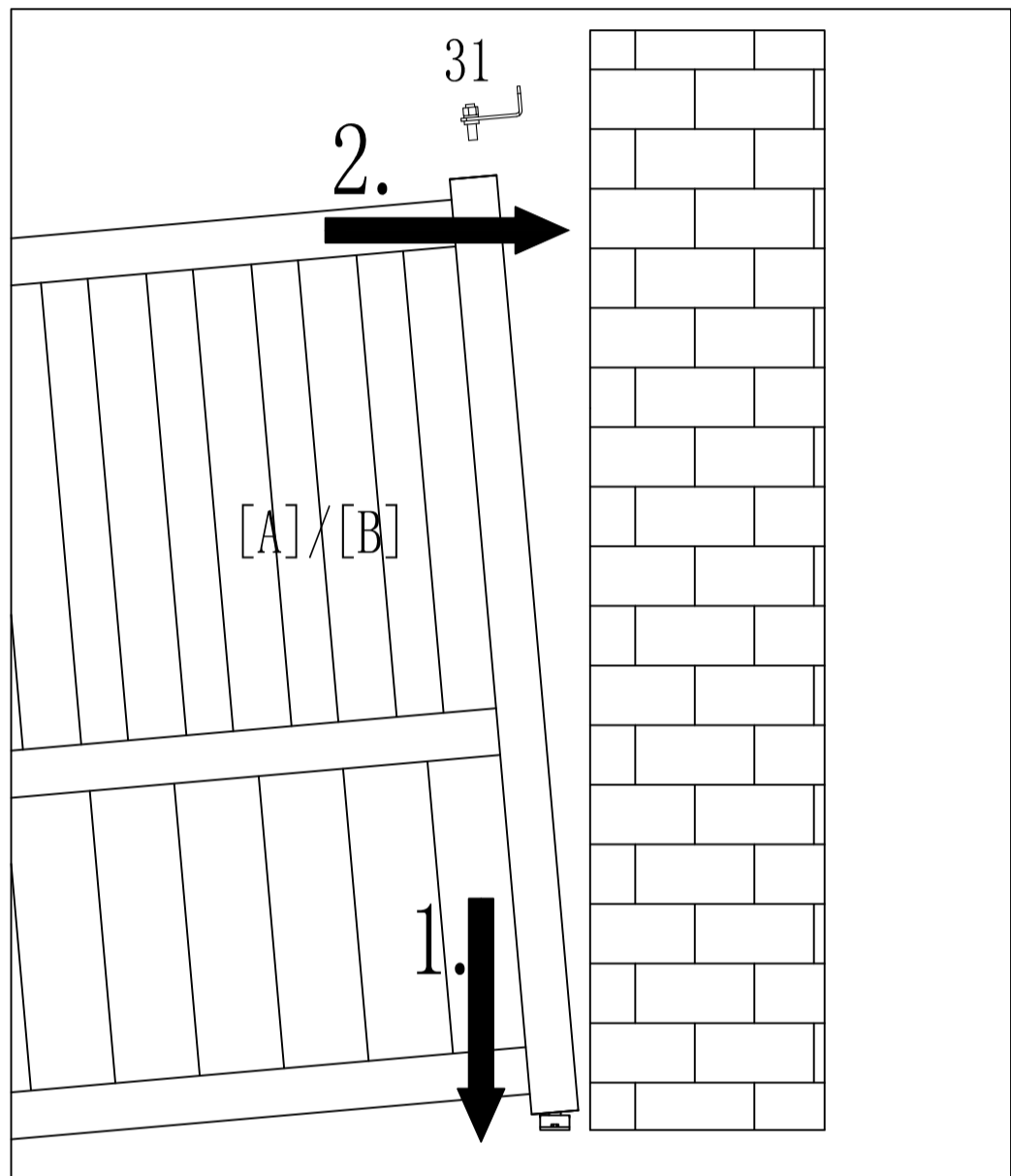
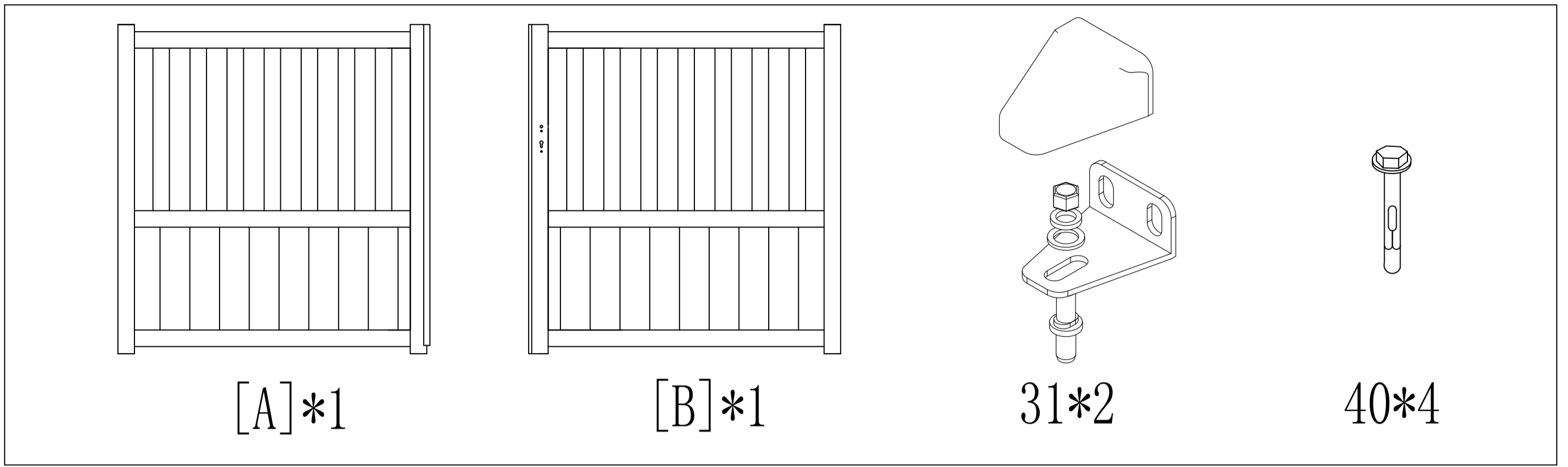

FR

Attention:

1. Si vous rencontrez des difficultés lors du montage des vis n ° 41 sur la poignée (34), veuillez desserrer les vis du corps de verrouillage, puis réessayer.
2. Pls justifiez le cylindre (36) aux trous de cylindre pré-perçés lors de l'installation du cylindre (36) sur la porte.

EN

Attention:

1. If you have difficulties when mounting No.41 screws on handle (34), pls loose the lock body screws, then try again.
2. Pls justify the cylinder (36) to the pre-drilled cylinder holes when install the cylinder (36) on gate.

DE

Beachtung:

1. Wenn Sie Schwierigkeiten beim Anbringen der Schrauben Nr. 41 am Griff (34) haben, lösen Sie bitte die Schrauben des Verriegelungskörpers und versuchen Sie es erneut.
2. Pls begründen den Zylinder (36) mit den vorgebohrten Zylinderlöchern, wenn der Zylinder (36) am Tor installiert wird.

ES

Atención:

1. Si tiene dificultades para montar los tornillos n. ° 41 en el mango (34), suelte los tornillos del cuerpo de la cerradura y vuelva a intentarlo.
2. Por favor, justifique el cilindro (36) en los orificios del cilindro pretaladrados cuando instale el cilindro (36) en la puerta.

IT

Attenzione:

1. In caso di difficoltà durante il montaggio delle viti n. 41 sulla maniglia (34), allentare le viti del corpo della serratura, quindi riprovare.
2. Pls giustificare il cilindro (36) ai fori del cilindro preforati quando si installa il cilindro (36) sul cancello.

NL

Aandacht:

1. Als u problemen ondervindt bij het monteren van nr. 41 schroeven op de handgreep (34), verwijder dan de schroeven van het slotlichaam en probeer het opnieuw.
2. Plug de cilinder (36) naar de voorgeboorde cilindergaten wanneer de cilinder (36) op de poort wordt geïnstalleerd.

PT

Atenção:

1. Se você tiver dificuldades ao montar os parafusos No.41 em uma alça (34), solte os parafusos do corpo da trava. Em seguida, tente novamente.
2. Por favor, justifique o cilindro (36) aos orifícios pré-perfurados ao instalar o cilindro (36) na comporta.

PL

Uwaga:

1. Jeśli masz trudności z zamontowaniem śrub nr 41 na klamce (34), poluzuj śruby korpusu zamka. Następnie spróbuj ponownie.
2. Pls wyrównaj cylinder (36) do wstępnie wywierconych otworów cylindra podczas instalowania cylindra (36) do bramy.

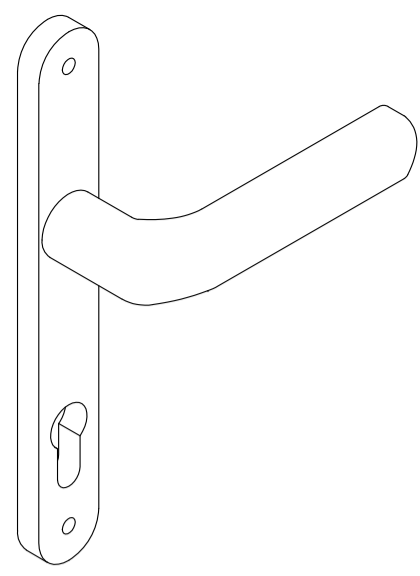

34*2

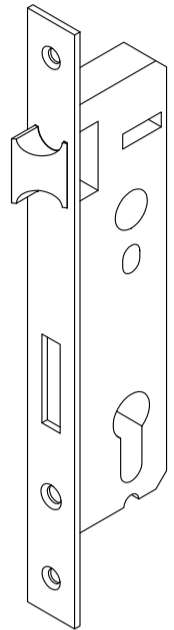

35*1

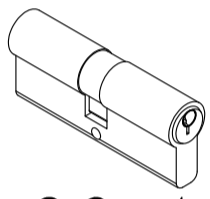

36*1

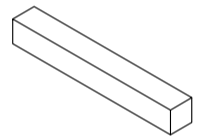

37*1

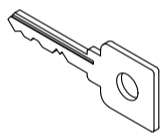

38*3



41*2



42*1



43*5

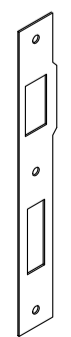

44*1

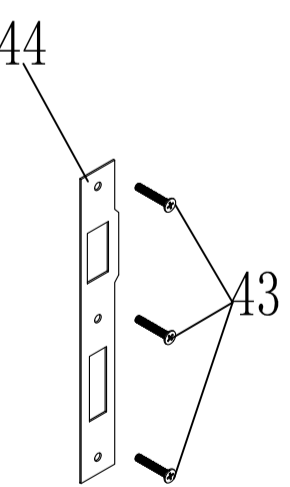
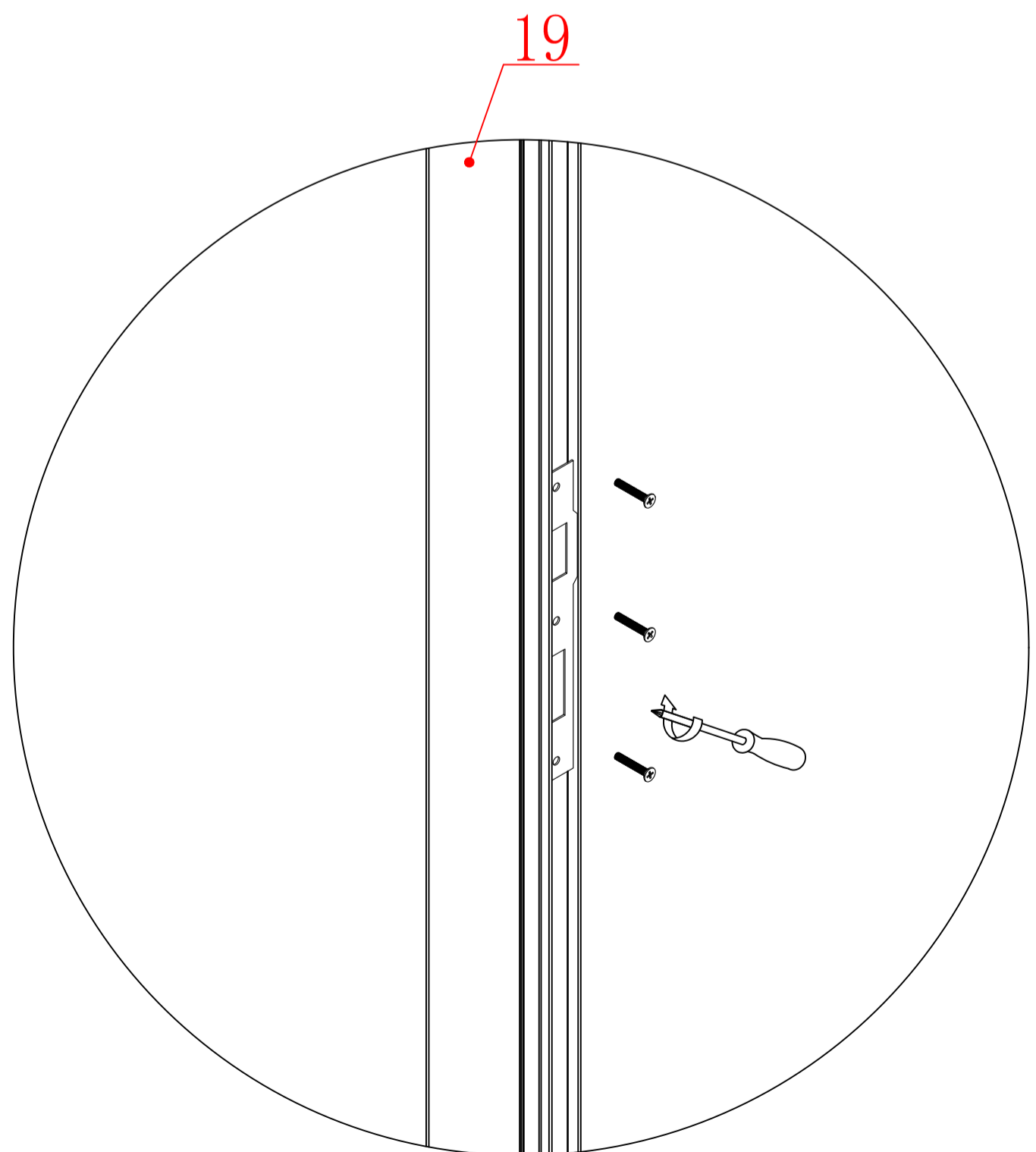
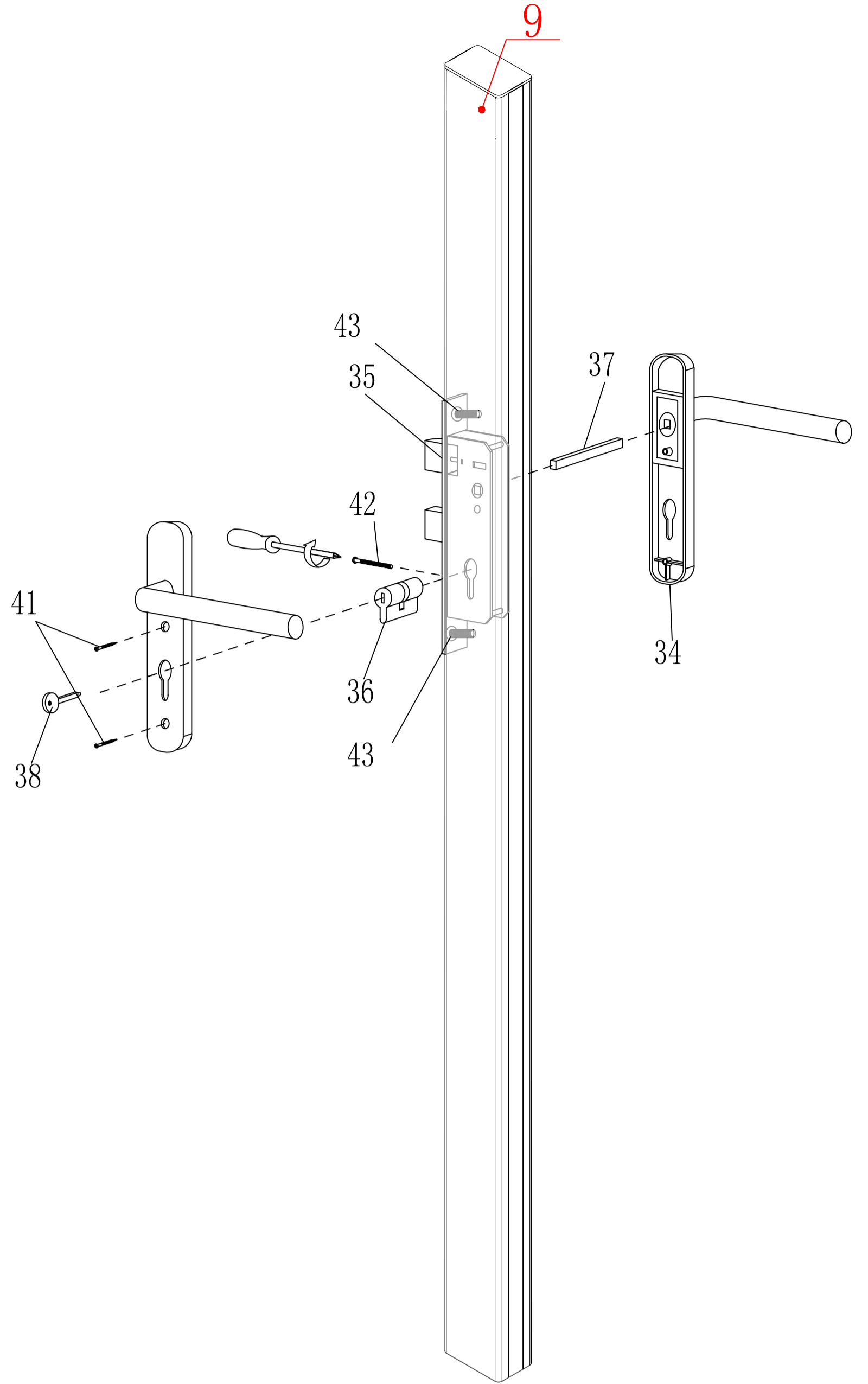

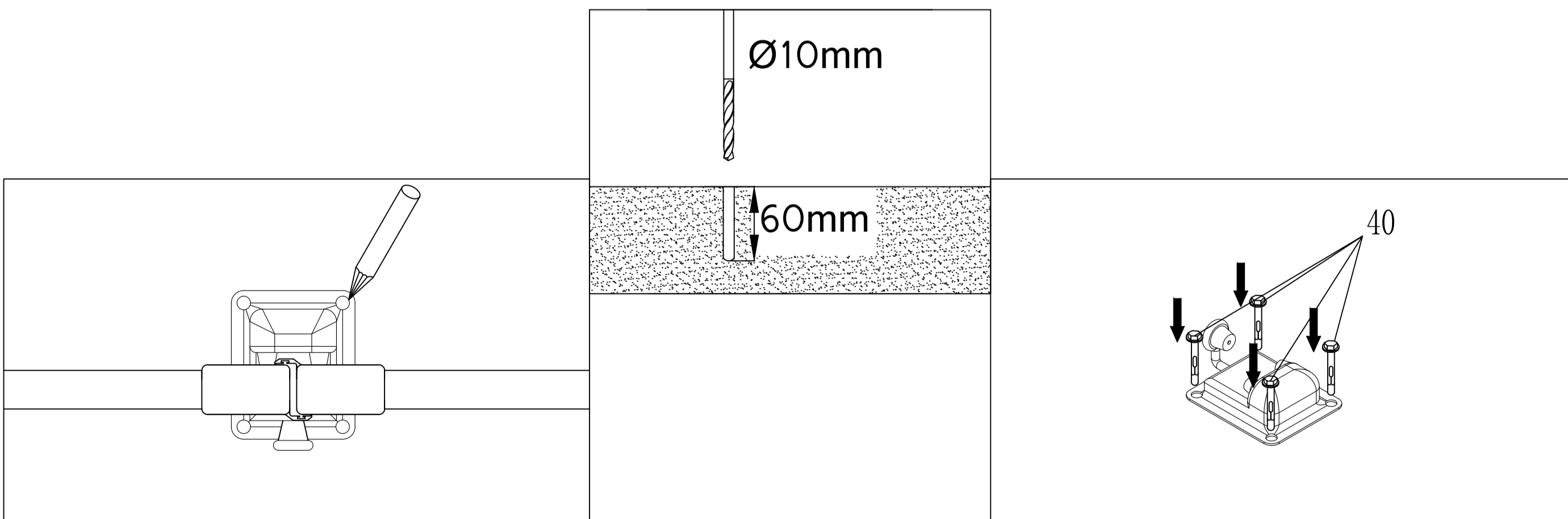
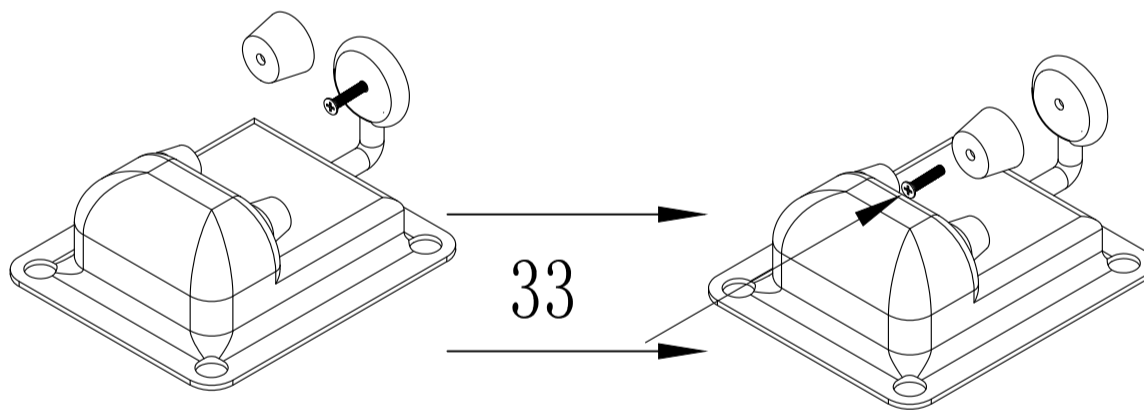
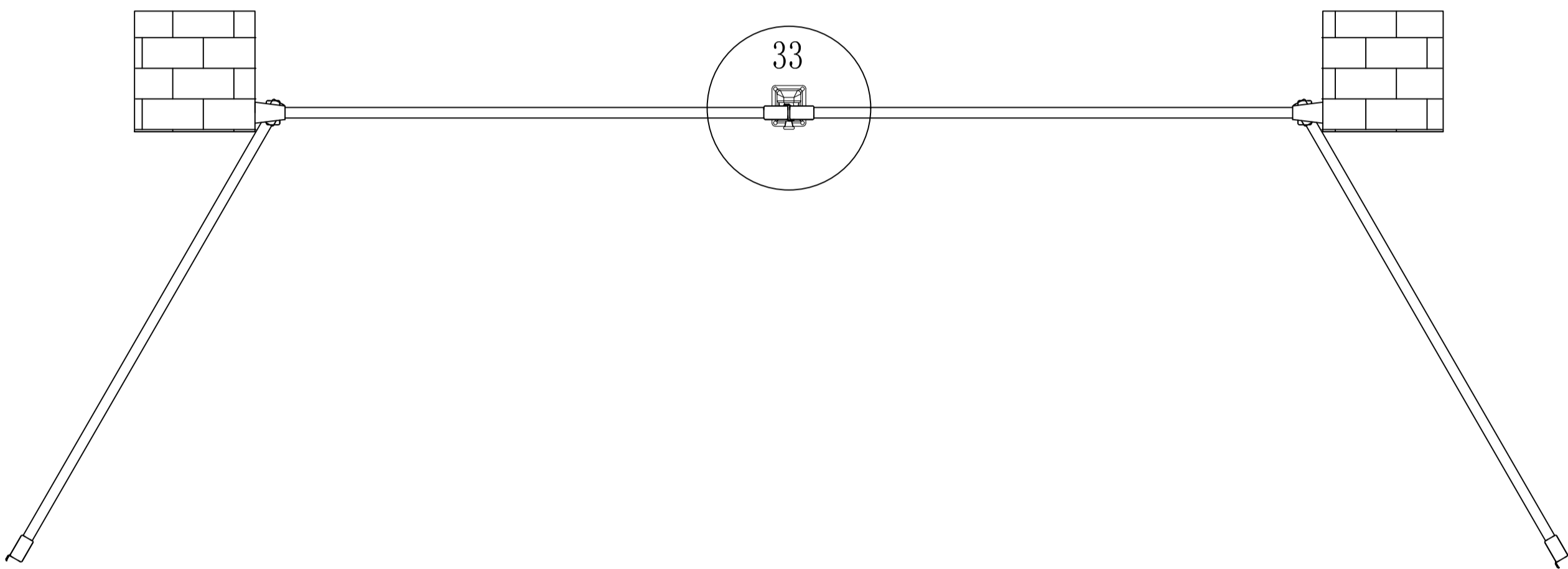
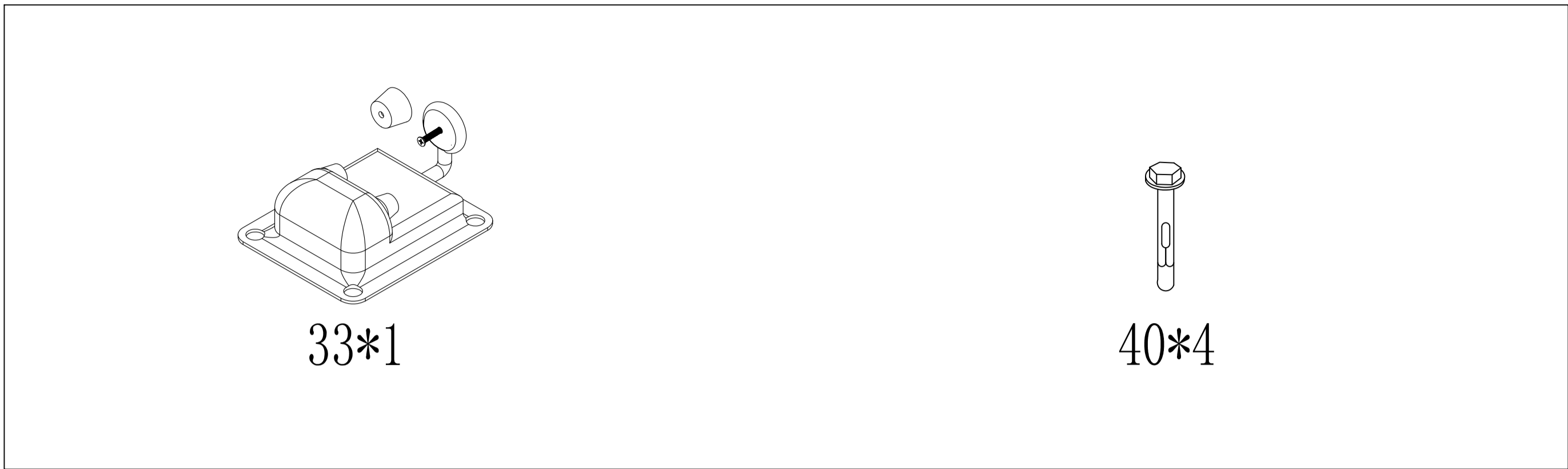

FR

Attention (pour l'installation de portail motorisé uniquement): Si le portail battant motorisé, les étapes d'installation de la serrure et de la butée de porte doivent suivre comme ci-dessous, les autres étapes sont les mêmes. Pour l'installation du moteur, veuillez vous référer au moteur IM.

EN

Attention (For motorized gate installation only): If motorized swing gate, the installing steps for the lock and the gate stopper are to follow as below, other steps are the same. For motor installation, pls refer the motor IM.

DE

Achtung (nur für die Installation von motorisierten Toren): Bei motorisiertem Flügeltor müssen die Installationsschritte für das Schloss und den Torstopper wie folgt ausgeführt werden, andere Schritte sind dieselben. Für die Motorinstallation beziehen Sie sich bitte auf den Motor IM.

ES

Atención (solo para instalación de portón motorizado): Si se trata de una puerta batiente motorizada, los pasos de instalación de la cerradura y el tope de la puerta se deben seguir como se indica a continuación, los demás pasos son los mismos. Para la instalación del motor, consulte el motor IM.

IT

Attenzione (solo per installazione su cancello motorizzato): In caso di cancello a battente motorizzato, le fasi di installazione della serratura e del fermo del cancello devono essere eseguite come di seguito, le altre fasi sono le stesse. Per l'installazione del motore, fare riferimento al motore IM.

NL

Let op (alleen voor gemotoriseerde poortinstallatie): Als een gemotoriseerde draaipoort, de installatiestappen voor het slot en de poortstopper volgen zoals hieronder, zijn de andere stappen hetzelfde. Raadpleeg voor motorinstallatie de motor IM.

PT

Atenção (somente para instalação de portão motorizado): Se o portão de batente motorizado, as etapas de instalação da fechadura e do batente do portão devem seguir como abaixo, as outras etapas são as mesmas. Para instalação do motor, consulte o motor IM.

PL

Uwaga (tylko w przypadku montażu bramy z napędem): Jeśli brama skrzydłowa z napędem silnikowym, kroki instalacji zamka i ogranicznika bramy należy wykonać jak poniżej, pozostałe kroki są takie same. W przypadku instalacji silnika, proszę odnieść się do silnika IM.

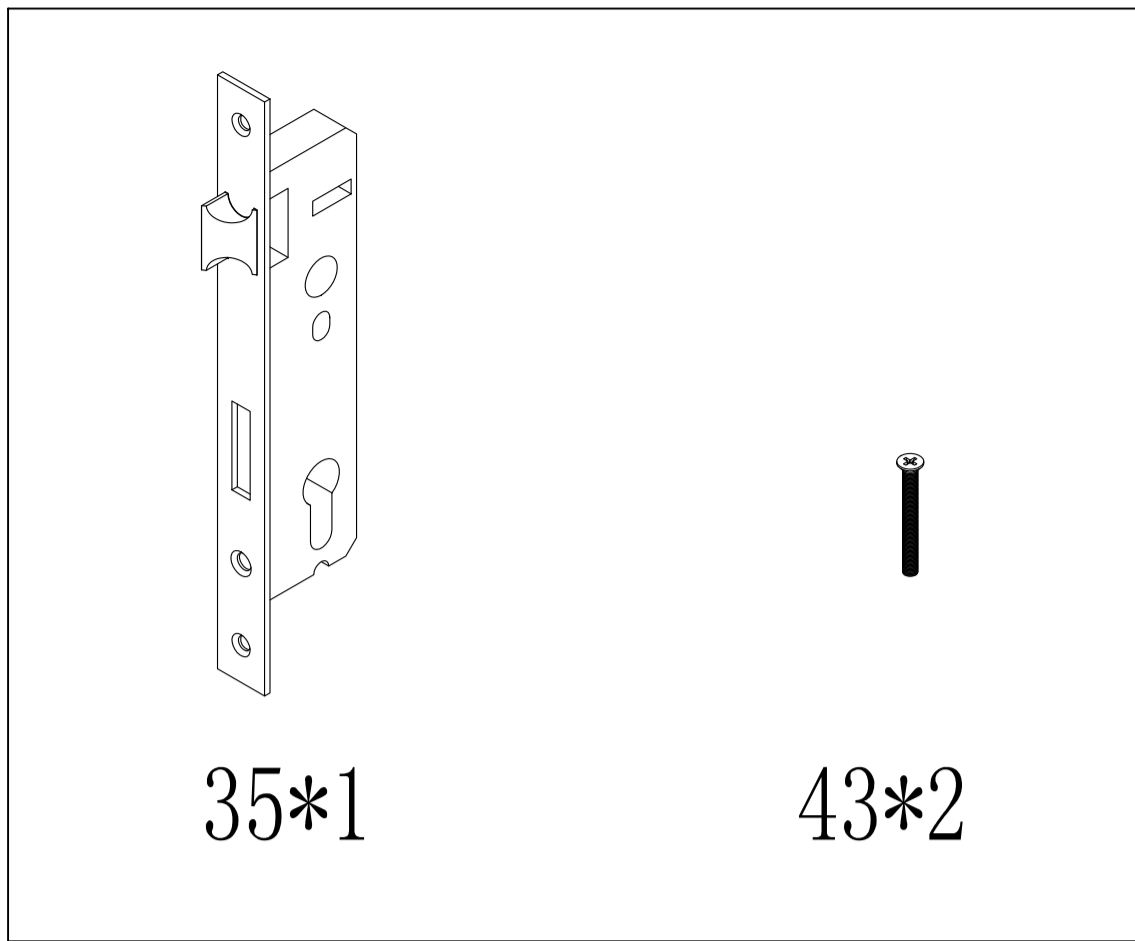

Démonter le n ° 35 (corps de serrure).
Disassemble No.35 (lock body).
Demontieren Sie Nr. 35 (Schlosskörper).
Desmontar el No 35 (cuerpo de la cerradura).
Smontare il n. 35 (corpo serratura).
Demonteer nr. 35 (slotlichaam).
Desmonte No.35 (corpo da fechadura).
Zdemontuj nr 35 (korpus zamka).

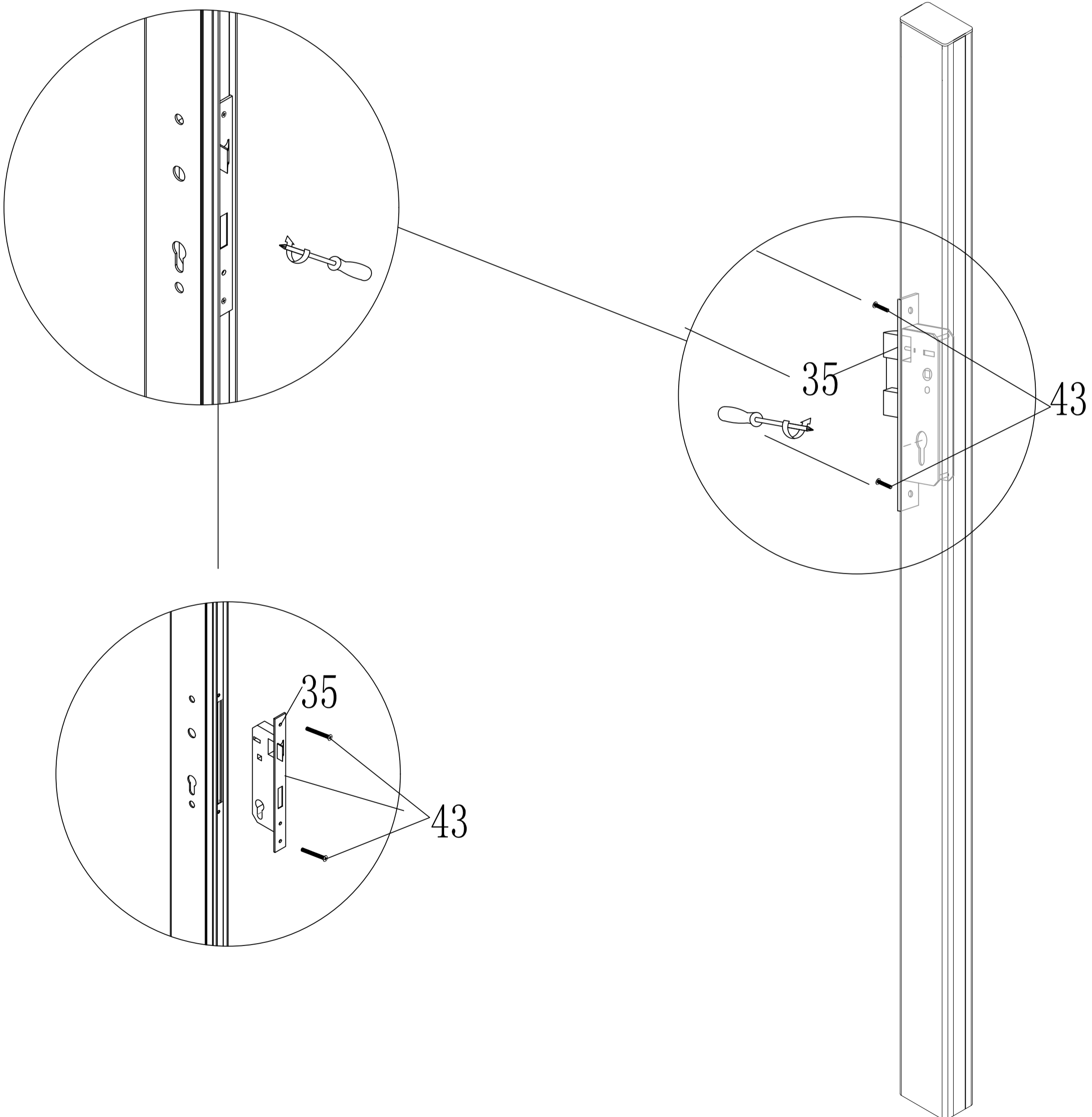

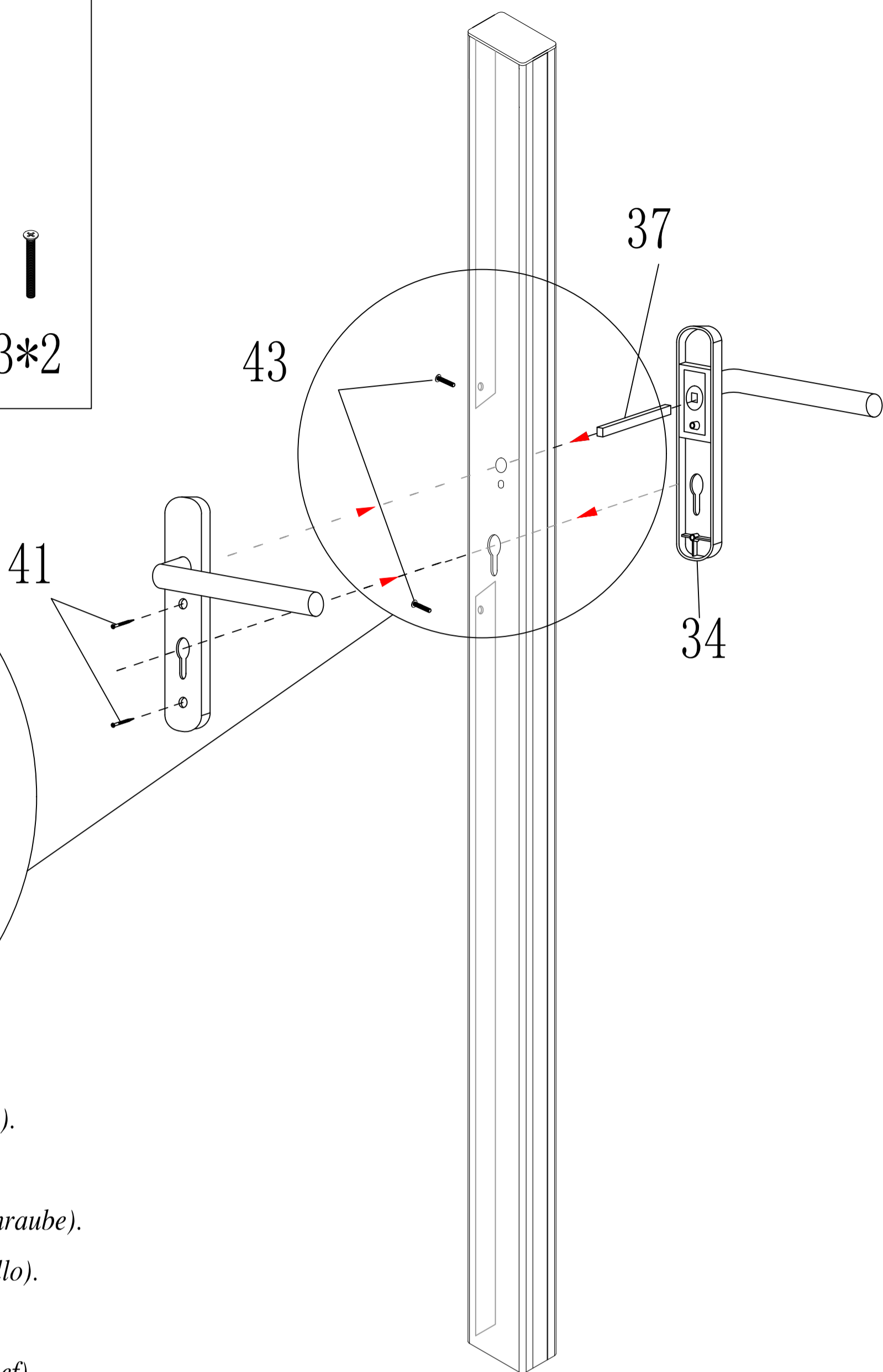
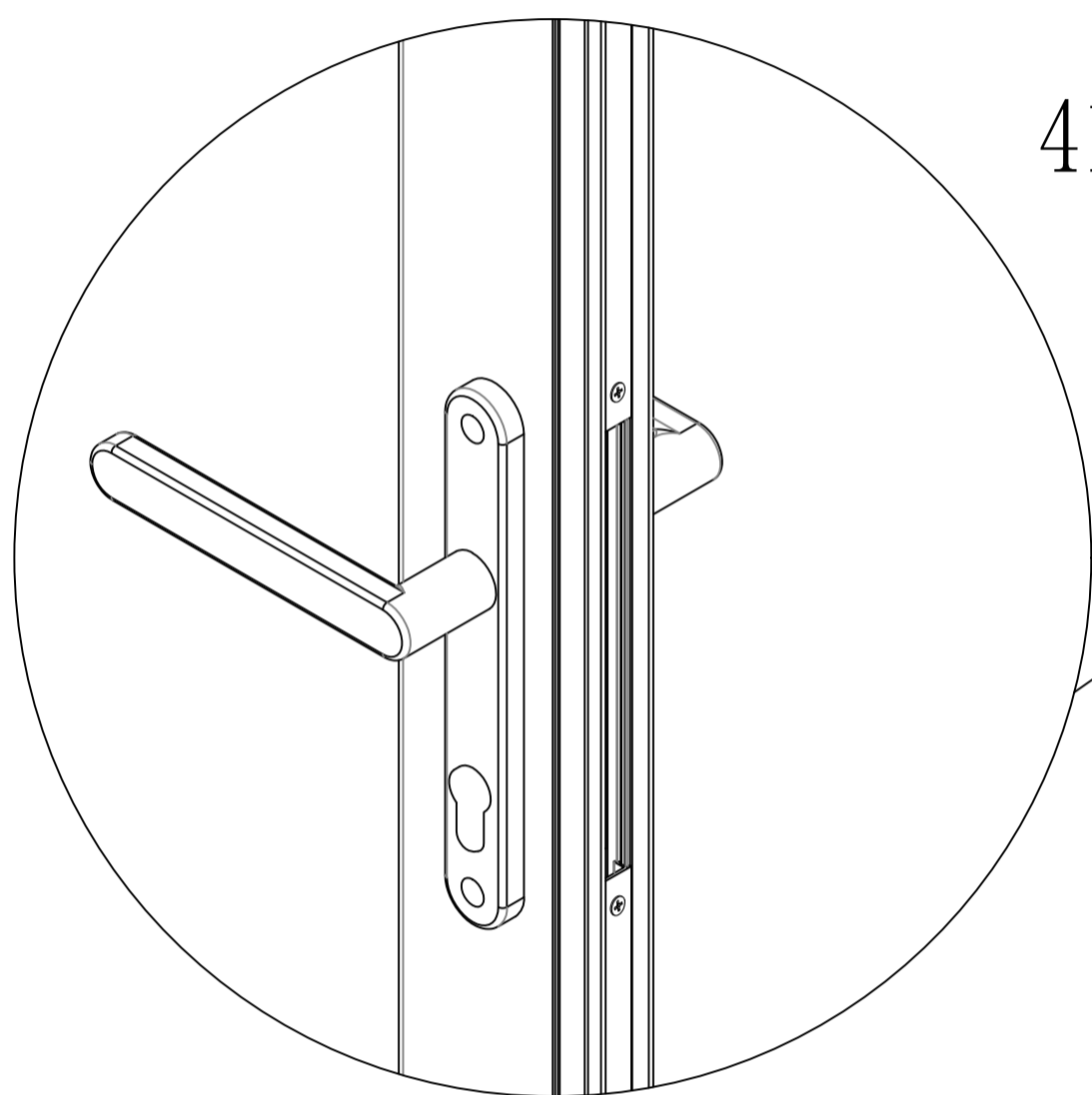
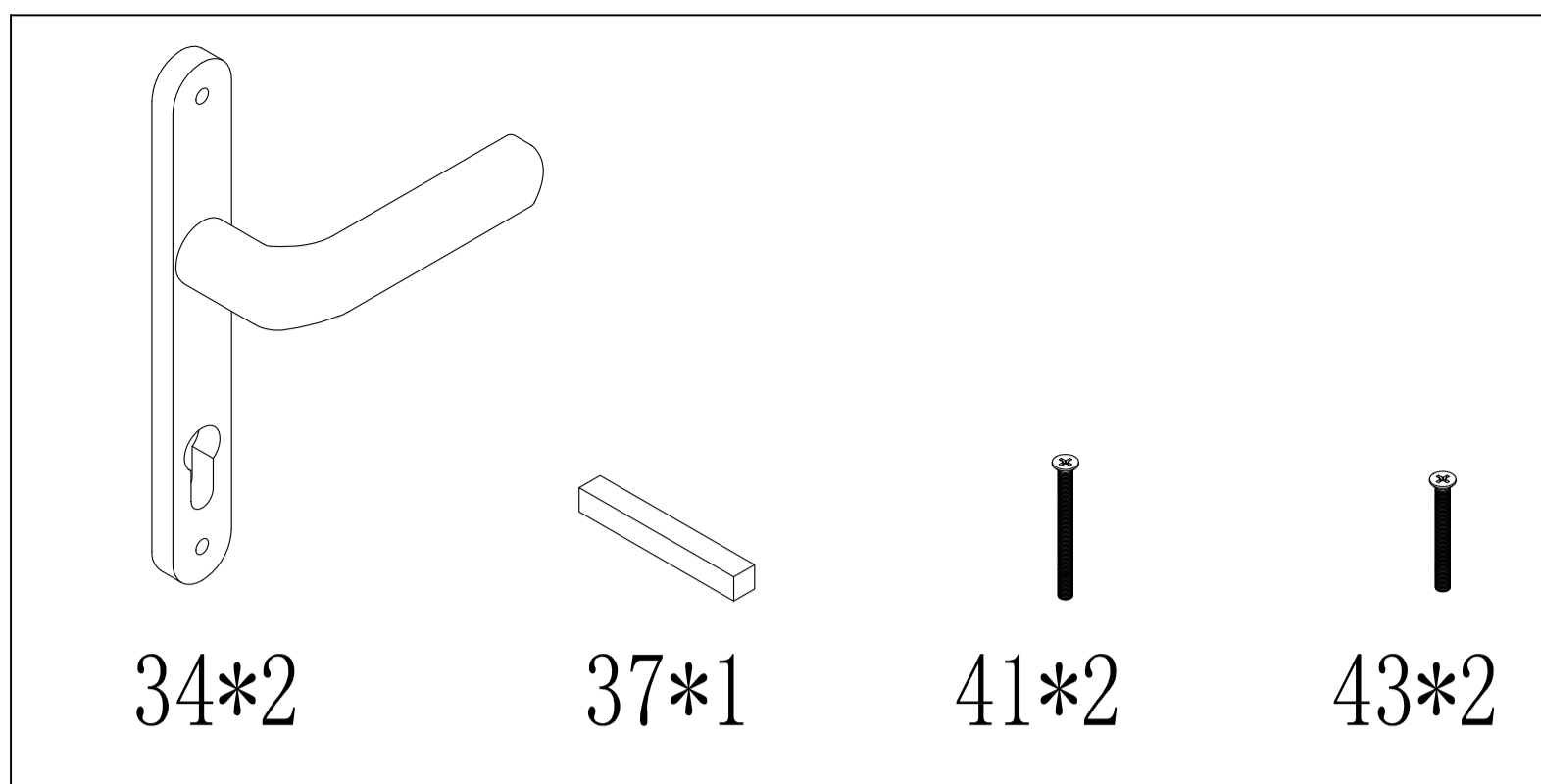

Installez le n° 34 (poignée), le n° 37 (barre carrée) par le n° 41 (vis).

Install No.34 (Handle), No.37 (Square bar) by No.41 (Screw).

Installieren Sie Nr. 34 (Griff), Nr. 37 (Vierkantstange) bei Nr. 41 (Schraube).

Instale el n.° 34 (mango), n.° 37 (barra cuadrada) por n.° 41 (tornillo).

Installare n. 34 (maniglia), n. 37 (barra quadrata) da n. 41 (vite).

Installeer nr. 34 (handvat), nr. 37 (vierkante staaf) door nr. 41 (schroef).

Instale No.34 (Alça), No.37 (Barra quadrada) pelo No.41 (Parafuso).

Zamontuj nr 34 (uchwyt), nr 37 (pręt kwadratowy) za nr 41 (śruba).

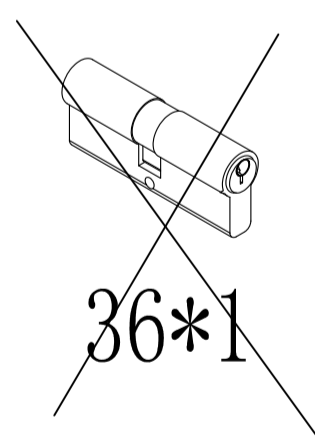
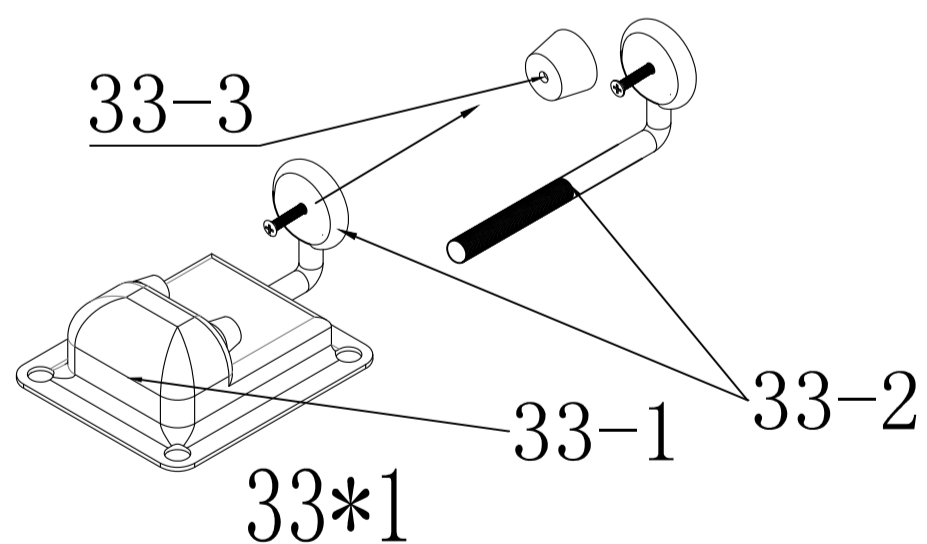

N'installez pas le n° 36 (cylindre).

Don't install the No.36 (cylinder).

Installieren Sie nicht die Nr. 36 (Zylinder).

No instale el No 36 (cilindro).

Non installare il n° 36 (cilindro).

Installeer de nr. 36 (cilinder) niet.

Não instale o No.36 (cilindro).

Nie instaluj nr 36 (cylinder).

Démontez le n° 33-2 et ne pas installer le n° 33-3, puis installez le n° 33 (butée de porte) directement.

Take apart No.33-2 and not to install No.33-3, then install No.33 (gate stopper) directly.

Nehmen Sie Nr. 33-2 auseinander und installieren Sie Nr. 33-3 nicht. Installieren Sie dann Nr. 33 (Torstopper) direkt.

Desmante el No.33-2 y no instale el No.33-3, luego instale el No.33 (tope de la puerta) directamente.

Smontare il n. 33-2 e non installare il n. 33-3, quindi installare direttamente il n. 33 (fermo del cancello).

Haal No.33-2 uit elkaar en niet om No.33-3 te installeren, installeer dan No.33 (gate stopper) direct.

Desmante o No. 33-2 e não instale o No. 33-3 e, a seguir, instale o No.33 (batente do portão) diretamente.

Rozebrać nr 33-2 i nie montować nr 33-3, a następnie zamontować bezpośrednio nr 33 (korek do bramy).

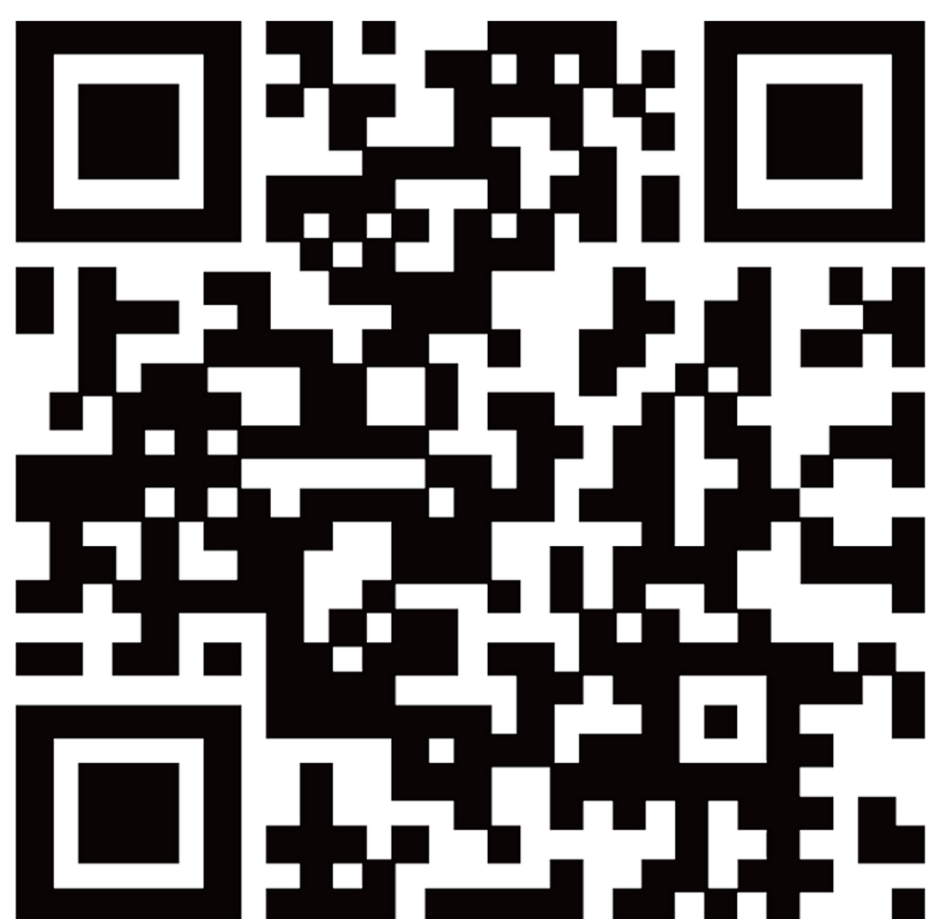

Vente-unique^{.com}

VS-AUG-2024

Imported by - Importé par
VENTE-UNIQUE.COM
9 Rue Jacquart 93310 Le Pré-Saint-Gervais
Made in China/ Fabriqué en Chine