

Installation sanleitung Installation Instruction Insturction d'instrallation

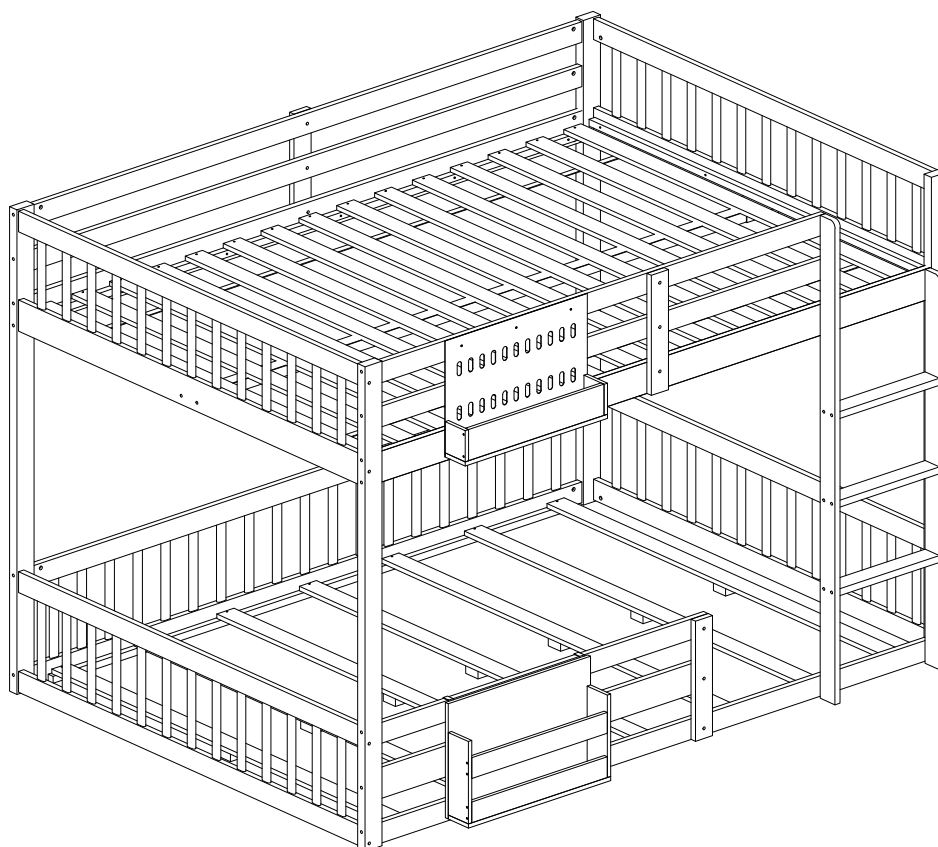

Unser Produkt wird Ihnen in 2 Paketen geliefert. Die Lieferzeiten dieser 2 Pakete können abweichen, bitte haben Sie etwas Geduld und vielen Dank für Ihr Verständnis.

Our product will be delivered to you in 2 packages. The delivery times of these 2 packages may differ, please be patient and thank you for your understanding.

Notre produit vous sera livré en 2 colis. Les délais de livraison de ces 2 colis peuvent différer, soyez patient et merci pour votre compréhension.

N636P446361

N636P446362

English

IMPORTANT ! KEEP FOR FUTURE REFERENCE : READ CAREFULLY

- To be assembled by an adult. Assembly must be checked by an adult before use
 - WARNING ! Keep all screws, small parts and plastic bags out of the reach of children
 - Properly identify all parts before assembling
 - Never use your item if any of its parts are broken or missing
 - Should any problems arise, please contact our After Sales Service
 - Manufacturer's instructions shall be followed at all times
 - Care: Clean with a soft, dry cloth. In case of larger stains, carefully rub with a slightly damp, non-abrasive sponge
 - Avoid the risk of fire by not placing furniture near sources of ignition or hot items
- Do not jump on the bed

Deutsch

WICHTIG ! ZUM SPÄTEREN NACHSCHLAGEN AUFBEWAHREN: SORGFÄLTIG LESEN

- Muss von einem Erwachsenen zusammengebaut werden. Der Zusammenbau muss vor dem Gebrauch von einem Erwachsenen überprüft werden
 - WARNUNG! Bewahren Sie alle Schrauben, Kleinteile und Plastikbeutel außerhalb der Reichweite von Kindern auf
 - Kennzeichnen Sie vor dem Zusammenbau alle Teile richtig
 - Benutzen Sie Ihren Artikel niemals, wenn Teile gebrochen sind oder fehlen
 - Sollten Probleme auftreten, wenden Sie sich bitte an unseren Kundendienst
 - Die Anweisungen des Herstellers sind stets zu befolgen
 - Pflege: Mit einem weichen, trockenen Tuch reinigen. Bei größeren Flecken vorsichtig mit einem leicht feuchten, nicht scheuernden Schwamm abreiben. nicht scheuernden Schwamm
 - Vermeiden Sie die Gefahr eines Brandes, indem Sie die Möbel nicht in der Nähe von Zündquellen oder heißen Gegenständen aufstellen
- Nicht auf das Bett springen

Français

IMPORTANT ! CONSERVER POUR RÉFÉRENCE ULTÉRIEURE : LIRE ATTENTIVEMENT

- Le montage doit être effectué par un adulte. Le montage doit être vérifié par un adulte avant Utilisation
 - ATTENTION ! Tenir les vis, les petites pièces et les sachets en plastique hors de portée des enfants
 - Identifiez correctement toutes les pièces avant de les assembler
 - N'utilisez jamais votre article si l'une de ses pièces est cassée ou manquante
 - En cas de problème, veuillez contacter notre service après-vente
 - Les instructions du fabricant doivent être respectées à tout moment
 - Entretien : nettoyer avec un chiffon doux et sec. En cas de taches plus importantes, frotter soigneusement avec une éponge non abrasive légèrement humide. légèrement humide et non Abrasive
 - Évitez les risques d'incendie en ne plaçant pas les meubles à proximité de sources d'inflammation ou d'objets chauds
- Ne pas sauter sur le lit

Italiano

IMPORTANTE! CONSERVARE PER RIFERIMENTO FUTURO: LEGGERE ATTENTAMENTE

- Deve essere assemblato da un adulto. L'assemblaggio deve essere controllato da un adulto prima dell'uso
- **ATTENZIONE!** Tenere tutte le viti, le piccole parti e i sacchetti di plastica fuori dalla portata dei bambini
- Identificare correttamente tutte le parti prima dell'assemblaggio
- Non utilizzare mai l'articolo se alcune parti sono rotte o mancanti
- In caso di problemi, si prega di contattare il nostro Servizio Post Vendita
- Le istruzioni del produttore devono essere sempre seguite
- Cura: Pulire con un panno morbido e asciutto. In caso di macchie più estese, strofinare accuratamente con una spugna leggermente umida e nonspugna leggermente umida e non abrasiva
- Evitare il rischio di incendio, non collocando i mobili vicino a fonti di accensione o a oggetti caldi
- Non saltare sul letto

Español

¡ IMPORTANTE ! CONSERVELO PARA FUTURAS CONSULTAS: LEA ATENTAMENTE

- Debe ser montado por un adulto. El montaje debe ser comprobado por un adulto antes del uso
- ADVERTENCIA** Mantenga todos los tornillos, piezas pequeñas y bolsas de plástico fuera del alcance de los niños.
- Identifique correctamente todas las piezas antes de montarlas
 - Nunca utilice su artículo si alguna de sus piezas está rota o falta
 - Si surge algún problema, póngase en contacto con nuestro Servicio Postventa
 - Las instrucciones del fabricante deben seguirse en todo momento
 - Cuidado: Limpiar con un paño suave y seco. En caso de manchas más grandes, frote cuidadosamente con una esponja no abrasiva ligeramente humedecida.
 - Evite el riesgo de incendio no colocando los muebles cerca de fuentes de ignición u objetos calientes.
 - No saltar sobre la cama.

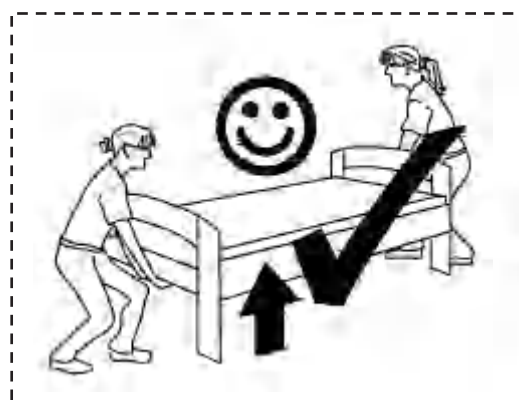
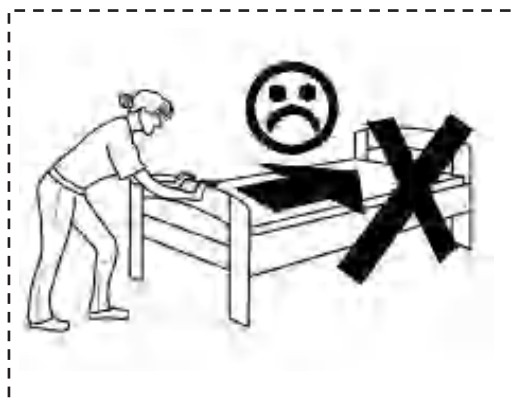

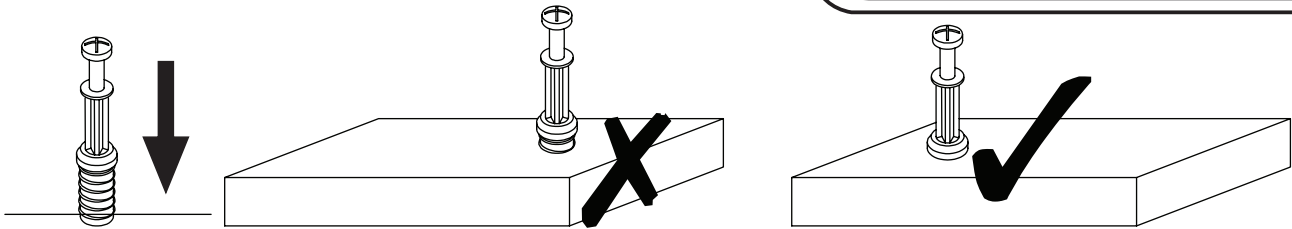

EN_QUICKFIT: Tighten quickfit until shoulder is flush with panel. Do not overtighten or undertighten.

FR_RACCORD RAPIDE: Faites serrer le raccord rapide jusqu'à ce que l'épaulement soit parfaitement encastré dans le panneau. Il ne faut ni trop serrer ni insuffisamment serrer.

ES_QUICKFIT: Apriete quickfit hasta que el hombro se descargue con el panel. NO lo sobreapriete ni lo apriete poco.

DE_QUICKFIT: Ziehen Sie den Quickfit fest, bis die Schulter mit der Platte bündig ist. Bitte nicht zu fest oder zu schwach anziehen.

IT_MONTAGGIO RAPIDO: Stringere il montaggio rapido fino a quando la spalla è a filo con il pannello, non stringere troppo o troppo poco.

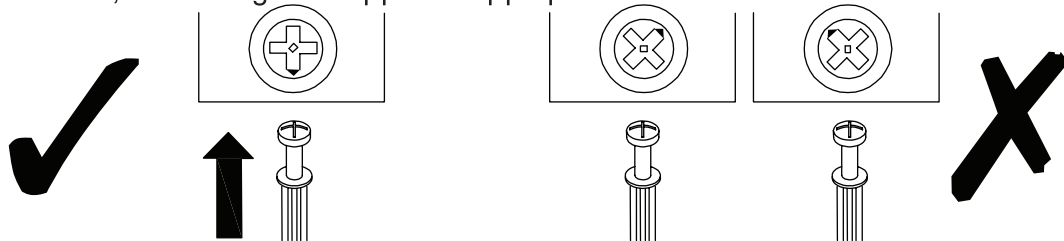

EN_CAM LOCK: When fitting cam lock, ensure starting position is correct before you insert connecting quickfit.

FR_SERRURE BATTEUSE: Avant d'insérer la serrure batteuse, veillez à la bonne orientation avant d'insérer le raccord rapide.

ES_CIERRE DE LA CÁMARA: Cuando instale el cierre de la cámara, asegúrese de que la posición de inicio es correcta antes de que inserte el quickfit conector.

DE_CAM-LOCK: Achten Sie bei der Montage des Cam-Locks auf die richtige Ausgangsposition, bevor Sie den Quickfit einsetzen.

IT_BLOCCAGGIO A CAMMA: Quando si monta il bloccaggio a camma, assicurarsi che la posizione iniziale sia corretta prima di inserire il montaggio rapido di collegamento.

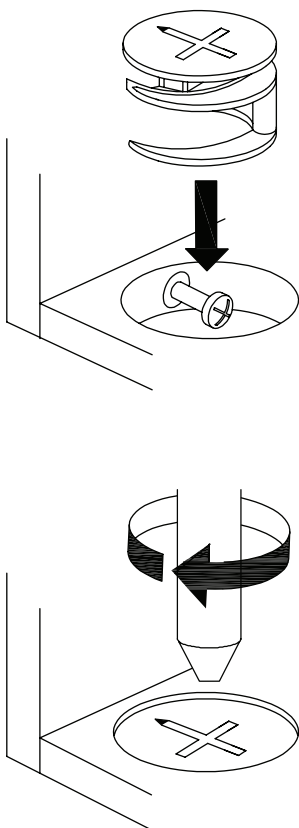

EN_Quickfit head should be in the centre of the cam lock when the two panels are joined.

Cam lock should be inserted before quickfit.

FR_Lorsque les deux panneaux sont assemblés, la tête du raccord rapide doit reposer au centre de la serrure batteuse.

Il faut insérer la serrure batteuse avant le raccord rapide.

ES_El cabezal del quickfit debe estar en el centro del cierre de la cámara cuando se unan los dos paneles.

Se debe insertar el cierre de la cámara antes que el quickfit.

DE_Der Quickfit-Kopf sollte sich in der Mitte des Cam-Locks befinden, wenn die beiden Platten zusammengefügt sind.

Der Cam-Lock sollte vor dem Quickfit eingesetzt werden.

IT_La testa del montaggio rapido deve trovarsi al centro del bloccaggio a camma quando i due pannelli sono uniti.

Il Bloccaggio a Camma deve essere inserito prima del montaggio rapido.

EN_Turn cam lock clockwise to tighten.

FR_Faites tourner la serrure batteuse dans le sens des aiguilles d'une montre pour la resserrer.

ES_Gire el cierre de la cámara en sentido horario para apretarlo.

DE_Drehen Sie den Cam-Lock im Uhrzeigersinn, um ihn festzuziehen.





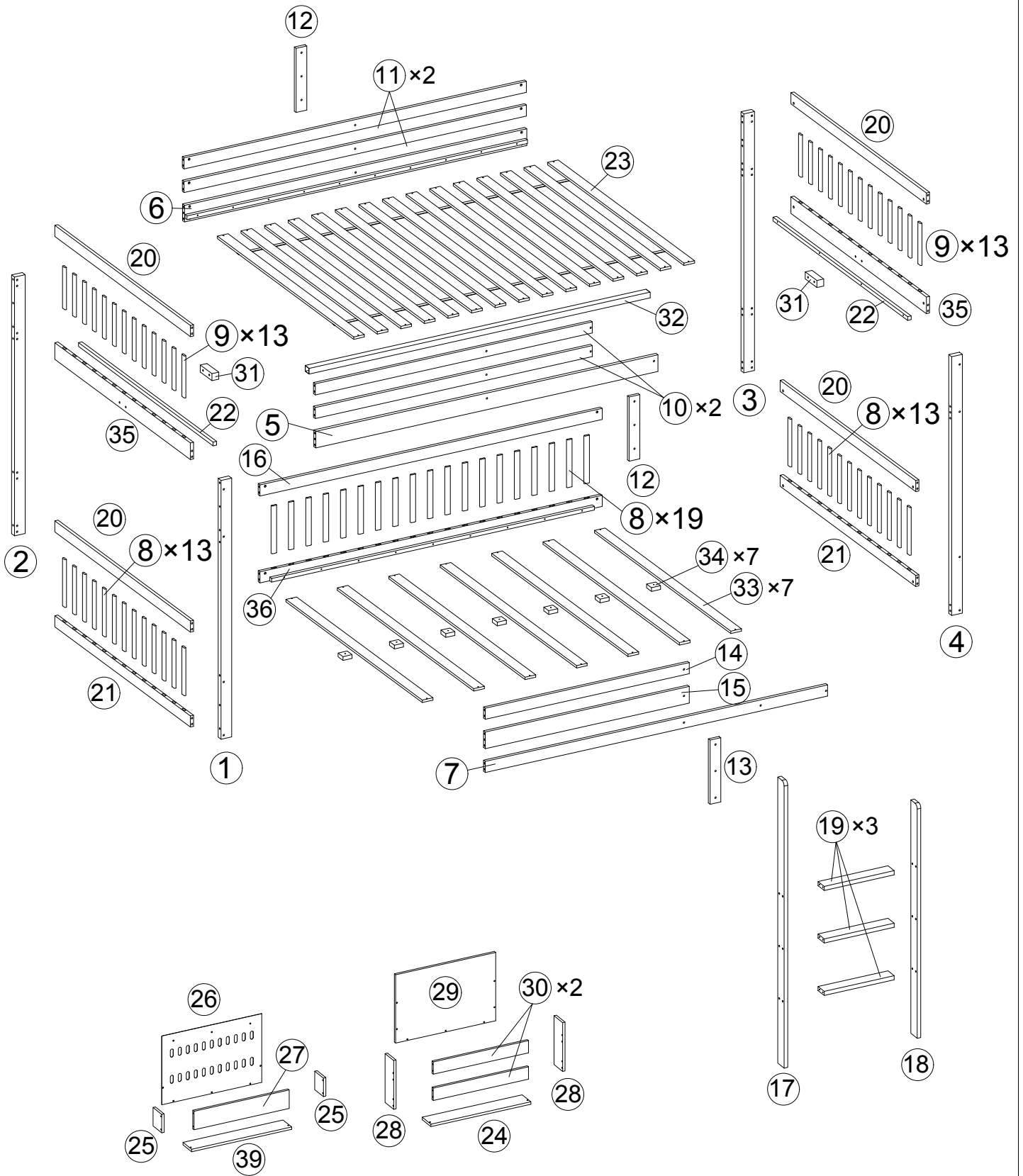





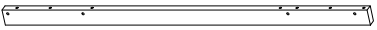

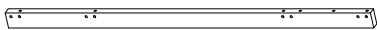
IT_Ruotare il bloccaggio a camma in senso orario per stringere.

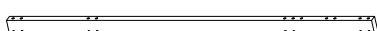
MONTAGEANLEITUNG/ASSEMBLY INSTRUCTIONS

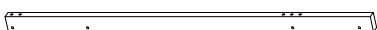

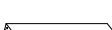



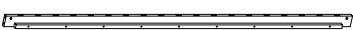





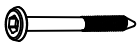
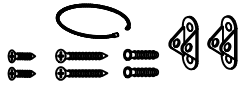

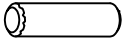

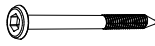

MONTAGEANLEITUNG/ASSEMBLY INSTRUCTIONS

N636P446361

1		1PC	10		2PCS
2		1PC	11		2PCS
3		1PC	15		1PC
4		1PC	16		1PC
5		1PC	19		3PCS
6		1PC	22		2PCS
7		1PC	32		1PC
Hardware box		1PC	36		1PC

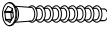
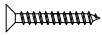
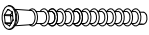











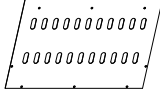
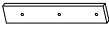

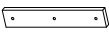
MONTAGEANLEITUNG/ASSEMBLY INSTRUCTIONS

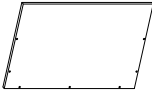
N636P446361 — Hardware box

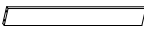
A	6x70		16PCS	K			2PCS
B	4x30		52PCS	L	M3		1PC
C	8x30		35PCS	M	M4		2PCS
D			38PCS	N			1PC
E	6x110		22PCS	O			2PCS
F	6x25		9PCS	P			2PCS
G	6x20		13PCS	Q	6x55		4PCS
H	5x40		23PCS	R	4x35		7PCS
I	7x60		18PCS	S			1PC
J	3x12		9PCS	T	3x16		5PCS

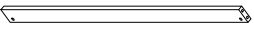
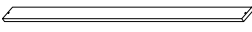
MONTAGEANLEITUNG/ASSEMBLY INSTRUCTIONS

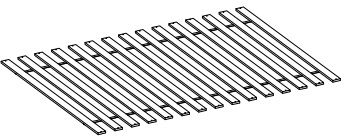
N636P446362

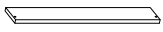
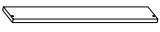
8		45PCS	25		2PCS
9		26PCS	26		1PC
12		2PCS	27		1PC
13		1PC	28		2PCS
14		1PC	29		1PC
17		1PC	30		2PCS
18		1PC	31		2PCS
20		4PCS	33		7PCS
21		2PCS	34		7PCS
23		1PC	35		2PCS
24		1PC	39		1PC

MONTAGEANLEITUNG/ASSEMBLY INSTRUCTIONS

E

22PCS

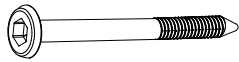

M6x110

A

16PCS



M6x70

Bitte beachten Sie, dass die Formen der Schrauben E und A ähnlich sind. Bitte installieren Sie entsprechend der Anleitung und unterscheiden Sie sie!

Please note that the shapes of screws E and A are similar.

Please install according to the instructions and distinguish them!

Notez que les vis E et A ont des formes similaires. Veuillez les installer en suivant les instructions pour les séparer!

J

9PCS

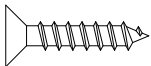

M3x12

B

52PCS

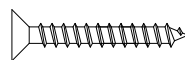

M4x30

R

7PCS

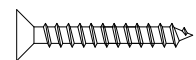

M4x35

Bitte beachten Sie, dass die Formen der Schrauben J und B und R ähnlich sind. Bitte installieren Sie entsprechend der Anleitung und unterscheiden Sie sie!

Please note that the shapes of screws J and B and R are similar.

Please install according to the instructions and distinguish them!

Notez que les vis J et B et R et ont des formes similaires. Veuillez les installer en suivant les instructions pour les séparer!

MONTAGEANLEITUNG/ASSEMBLY INSTRUCTIONS

H 23PCS

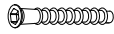

ø5x40

I 18PCS

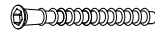

ø7x60

Bitte beachten Sie, dass die Formen der Schrauben H und I ähnlich sind. Bitte installieren Sie entsprechend der Anleitung und unterscheiden Sie sie!

Please note that the shapes of screws H and I are similar.

Please install according to the instructions and distinguish them!

Notez que les vis H et I ont des formes similaires. Veuillez les installer en suivant les instructions pour les séparer!

F 9PCS



M6x25

Q 4PCS



M6x50

Bitte beachten Sie, dass die Formen der Schrauben F und Q ähnlich sind. Bitte installieren Sie entsprechend der Anleitung und unterscheiden Sie sie!

Please note that the shapes of screws F and Q are similar.

Please install according to the instructions and distinguish them!

Notez que les vis F et Q ont des formes similaires. Veuillez les installer en suivant les instructions pour les séparer!

Vor dem Einbau die Schrauben in die Löcher stecken und festziehen, aber nicht bis 100%, 70% bis 80% anziehen reicht aus. Schließlich, nachdem alle Schrauben installiert sind, ziehen Sie alle Schrauben auf 100%.

Wenn Sie auf diese Probleme stoßen, wie z. B. Fehlausrichtung der Löcher oder Unfähigkeit, bestimmte Teile zu installieren, überprüfen Sie bitte, ob die Schrauben korrekt verwendet werden und passen Sie die Dichtigkeit der Schrauben an.

Before installation, insert the screws into the holes and tighten them, but do not tighten them to 100%, 70% to 80% is sufficient. Finally, after all screws are installed, tighten all screws to 100%. If you encounter these issues, such as if the holes cannot be aligned or some parts cannot be installed, please check if the screws are used correctly and adjust the tightness of the screws.

Insérer la vis dans le trou avant la fin de l'assemblage, serrer la vis, mais ne pas serrer à 100%, 70% ~ 80% est correct. Enfin, une fois que toutes les vis sont bien serrées, toutes les vis sont serrées à 100%.

Si vous rencontrez ces problèmes, par exemple si les trous ne sont pas alignés ou si certaines pièces ne peuvent pas être montées, vérifiez que les vis sont utilisées correctement et Ajustez leur serrage.

MONTAGEANLEITUNG/ASSEMBLY INSTRUCTIONS

1

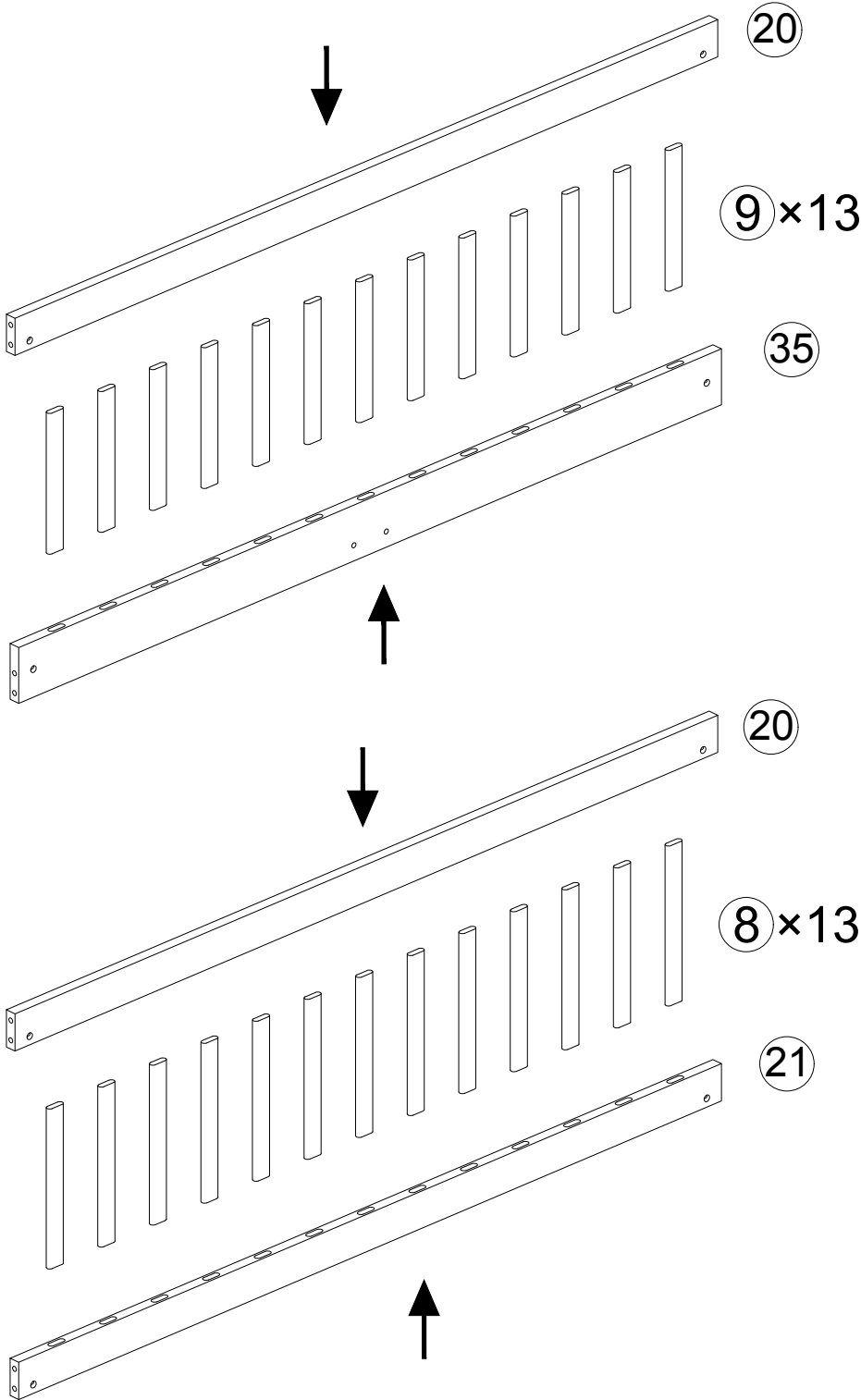



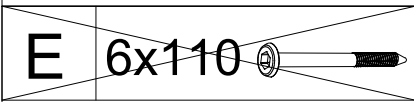
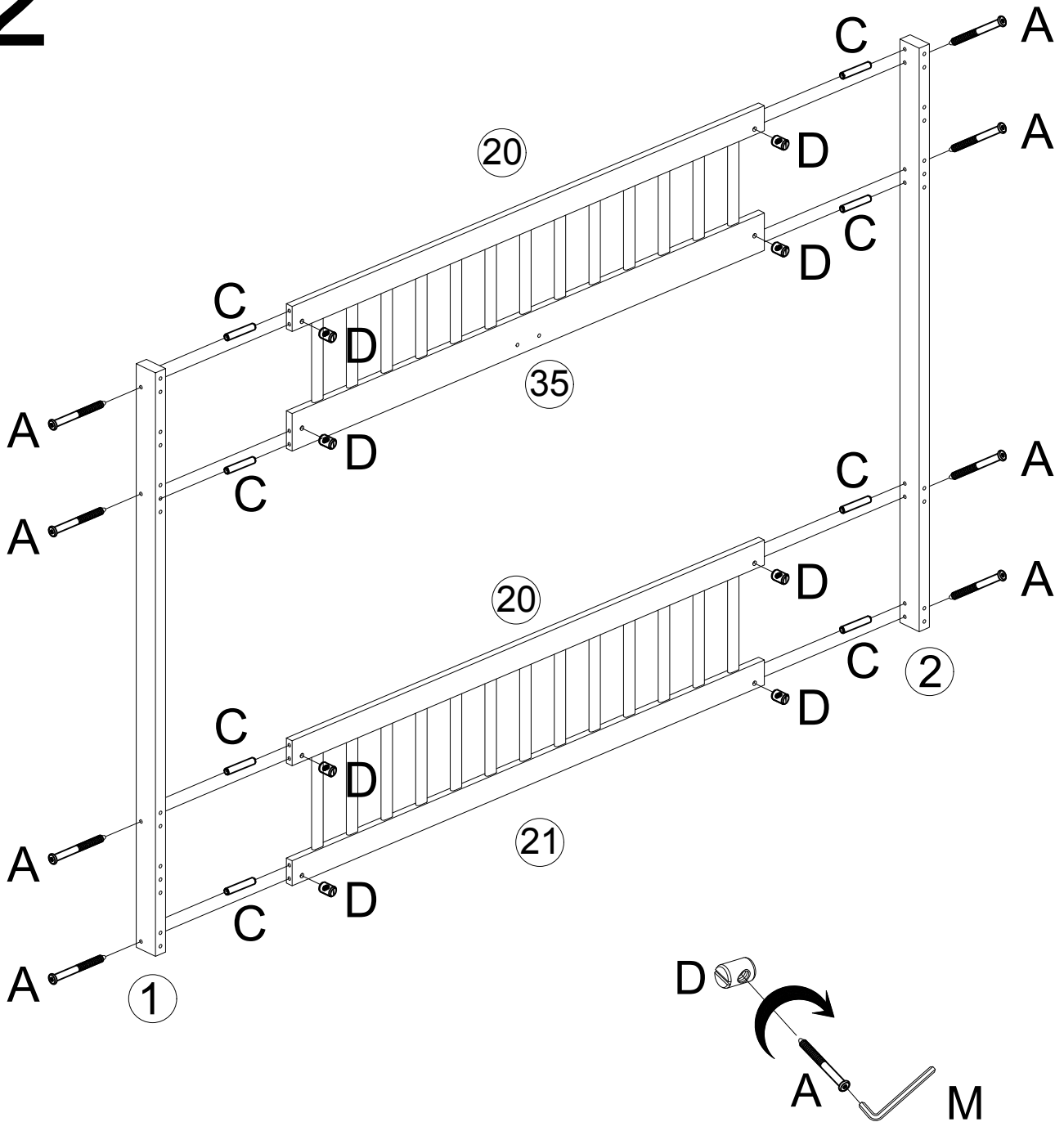

×2

MONTAGEANLEITUNG/ASSEMBLY INSTRUCTIONS

2



A	6x70		8PCS	D		8PCS
C	8x30		8PCS	M	M4 	1PC

MONTAGEANLEITUNG/ASSEMBLY INSTRUCTIONS

3

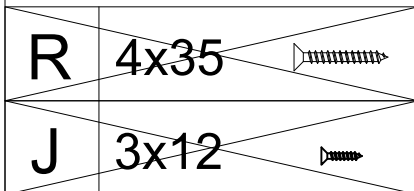
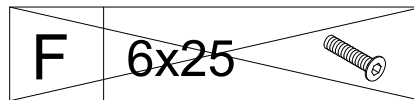
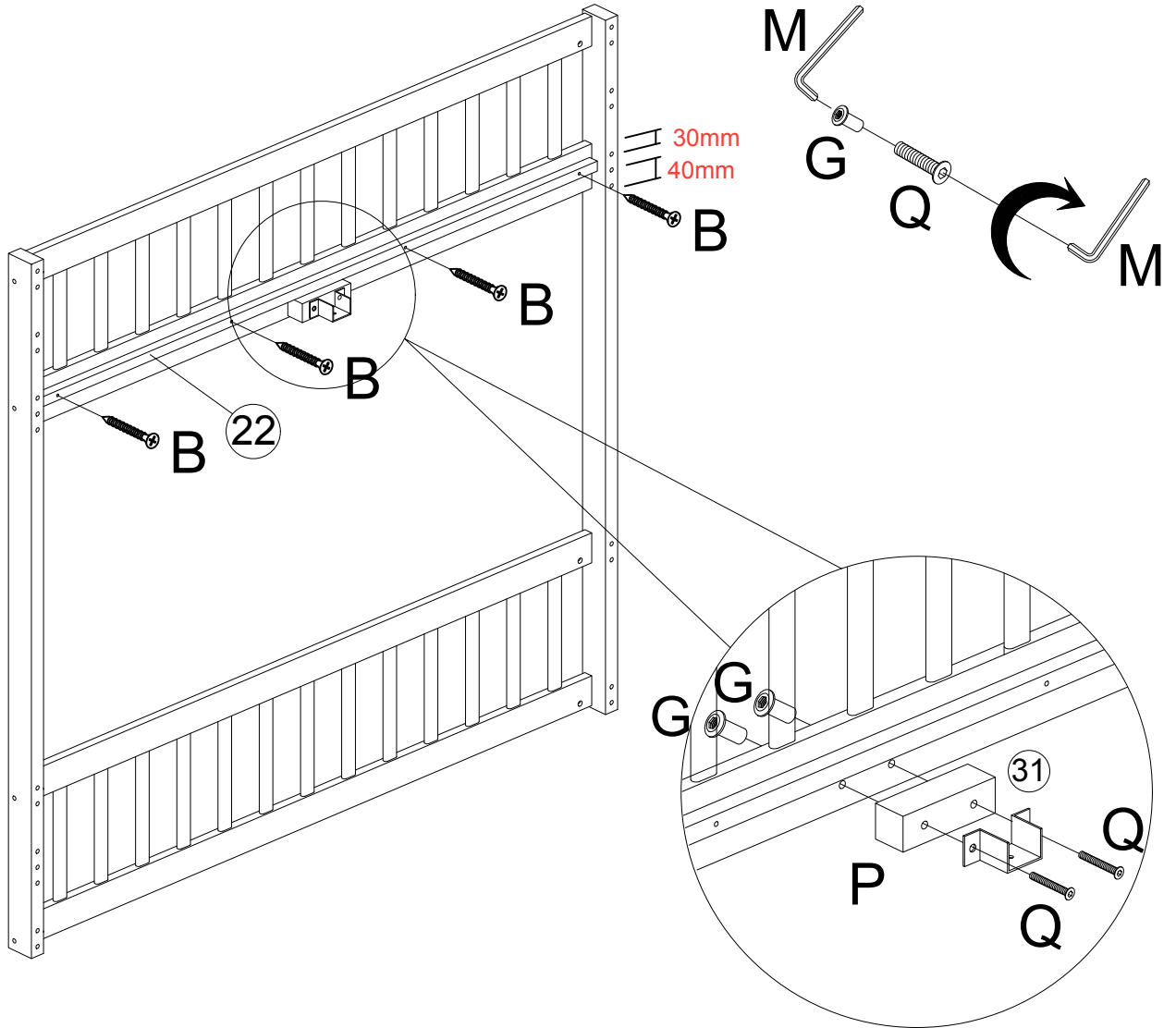

B	4x30		4PCS	P		1PC	
N			1PC	M	M4		2PCS
				Q	6x55		2PCS
				G	6x20		2PCS

MONTAGEANLEITUNG/ASSEMBLY INSTRUCTIONS

4

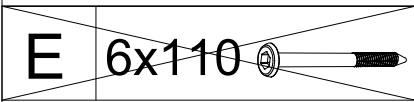
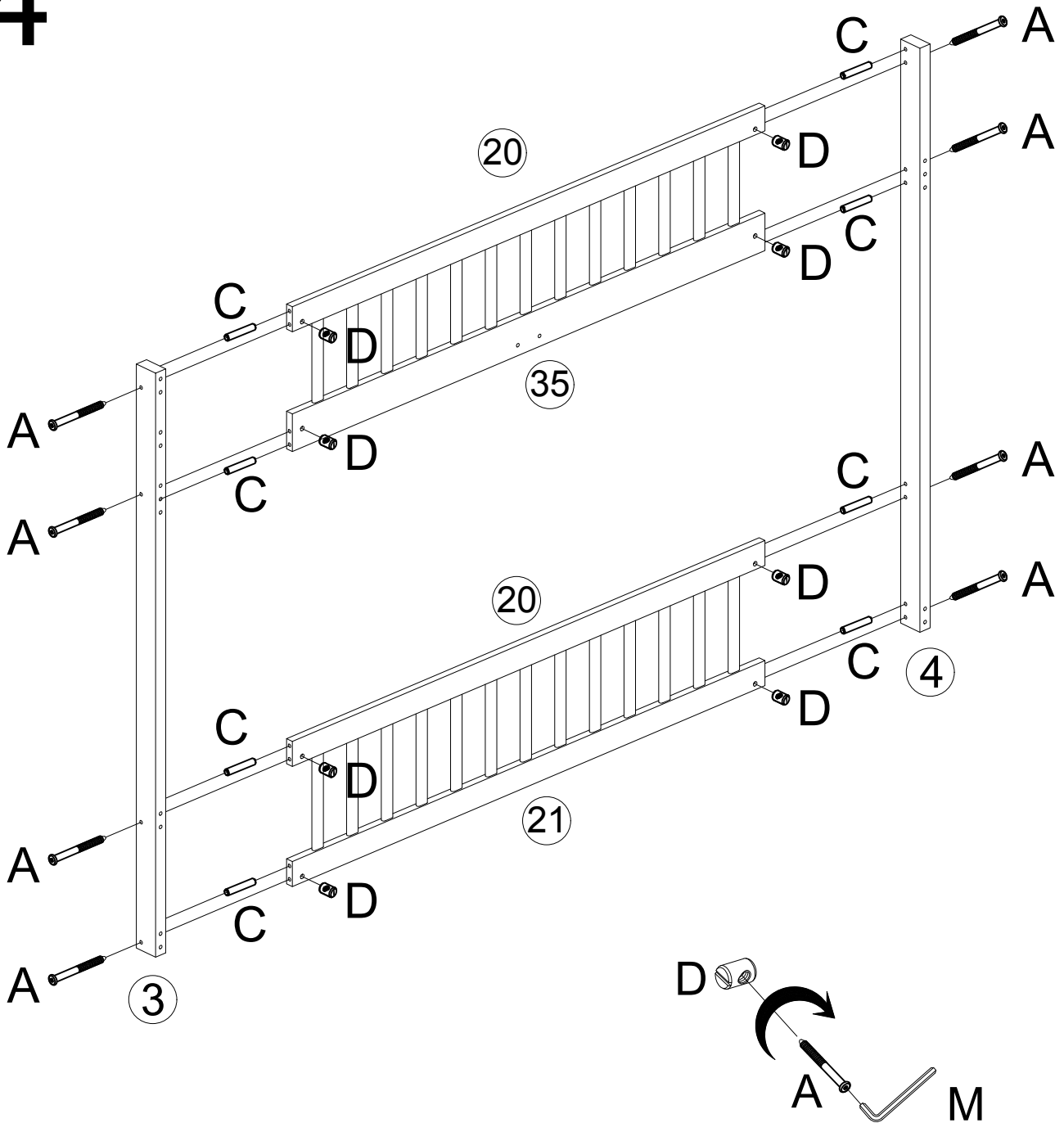



A	6x70		8PCS	D		8PCS
C	8x30		8PCS	M	M4	1PC



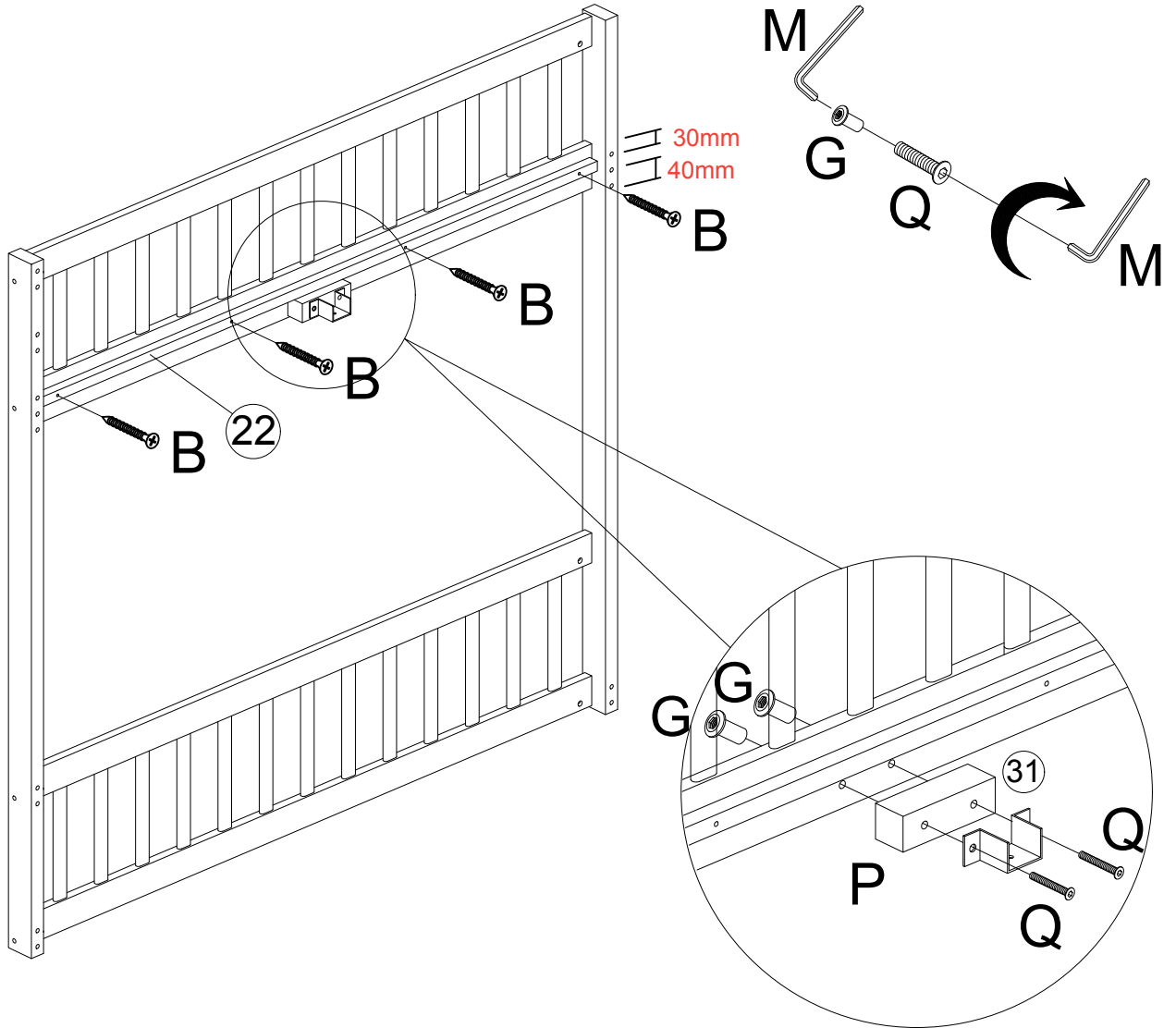

MONTAGEANLEITUNG/ASSEMBLY INSTRUCTIONS



5



R	4x35	
J	3x12	

F	6x25	
---	------	--





B	4x30		4PCS	P		1PC	
N			1PC	M	M4		2PCS

Q	6x55		2PCS
G	6x20		2PCS

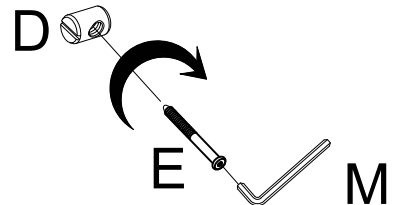
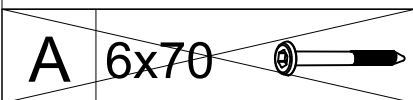
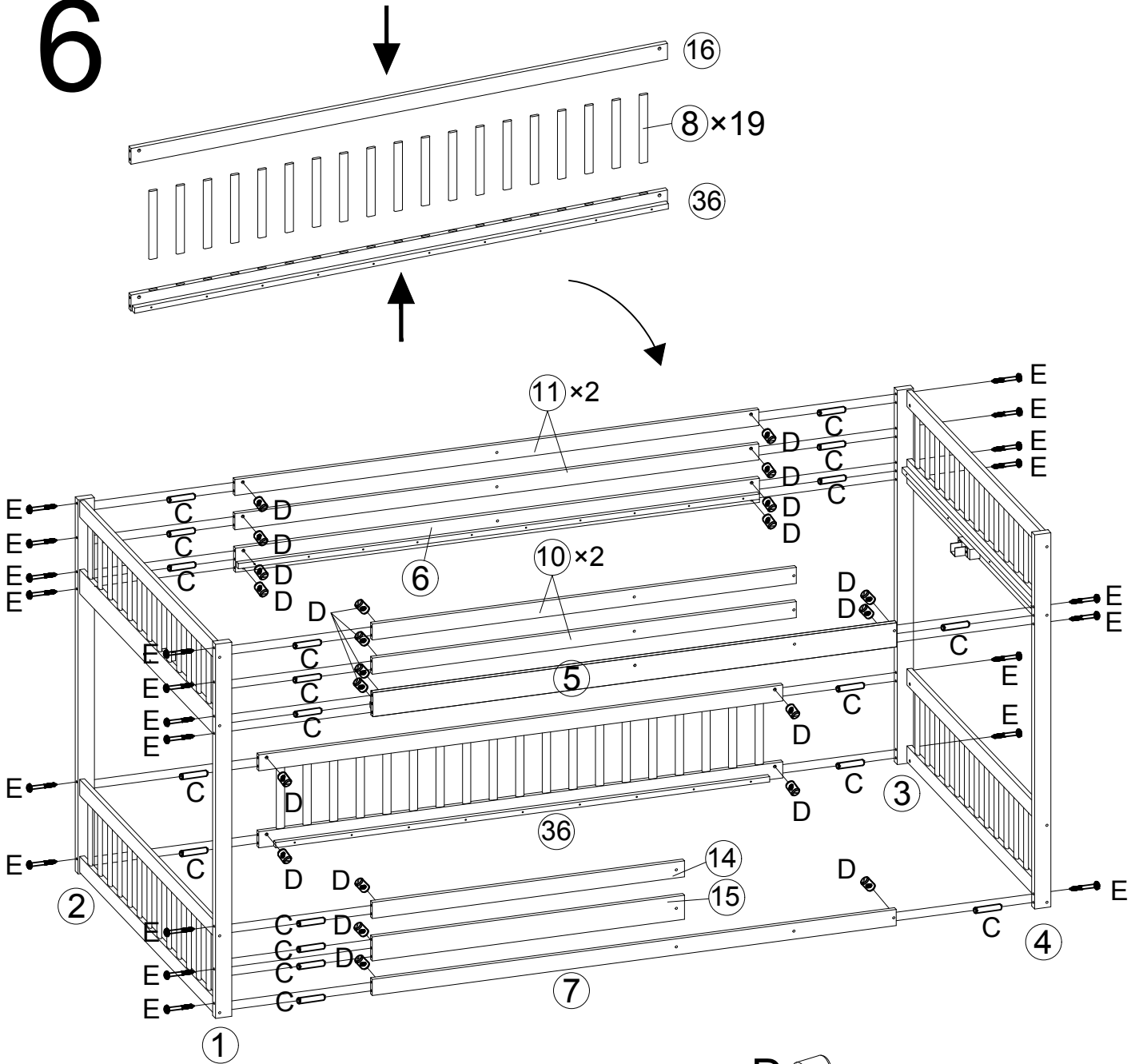
MONTAGEANLEITUNG/ASSEMBLY INSTRUCTIONS

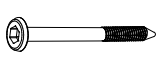
6





E	6x110		22PCS	D		22PCS
C	8x30		19PCS	M	M4 	1PC

MONTAGEANLEITUNG/ASSEMBLY INSTRUCTIONS

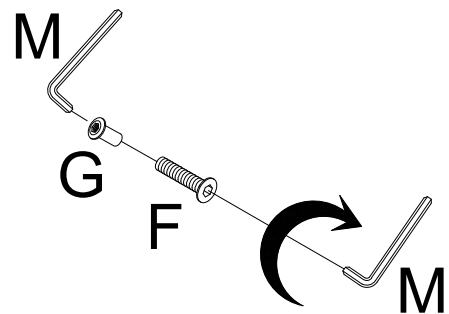
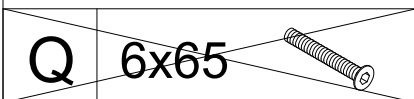
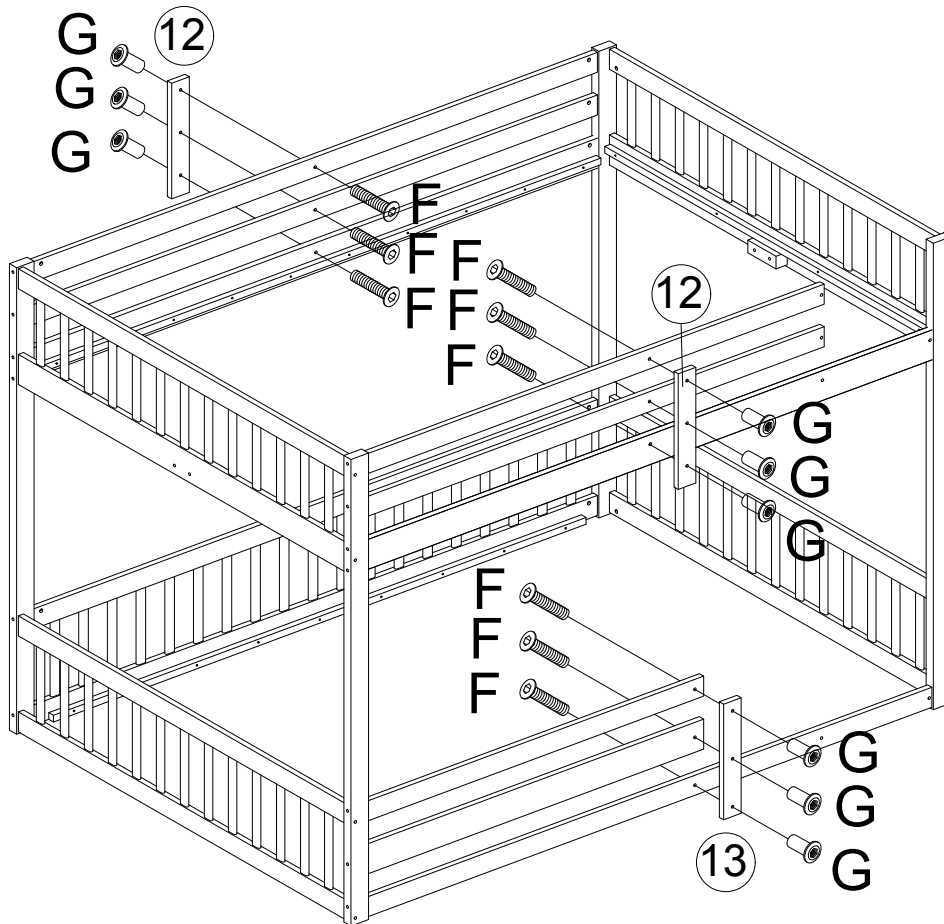
7



F	6x25		9PCS				
G	6x20		9PCS	M	M4		2PCS

MONTAGEANLEITUNG/ASSEMBLY INSTRUCTIONS

8

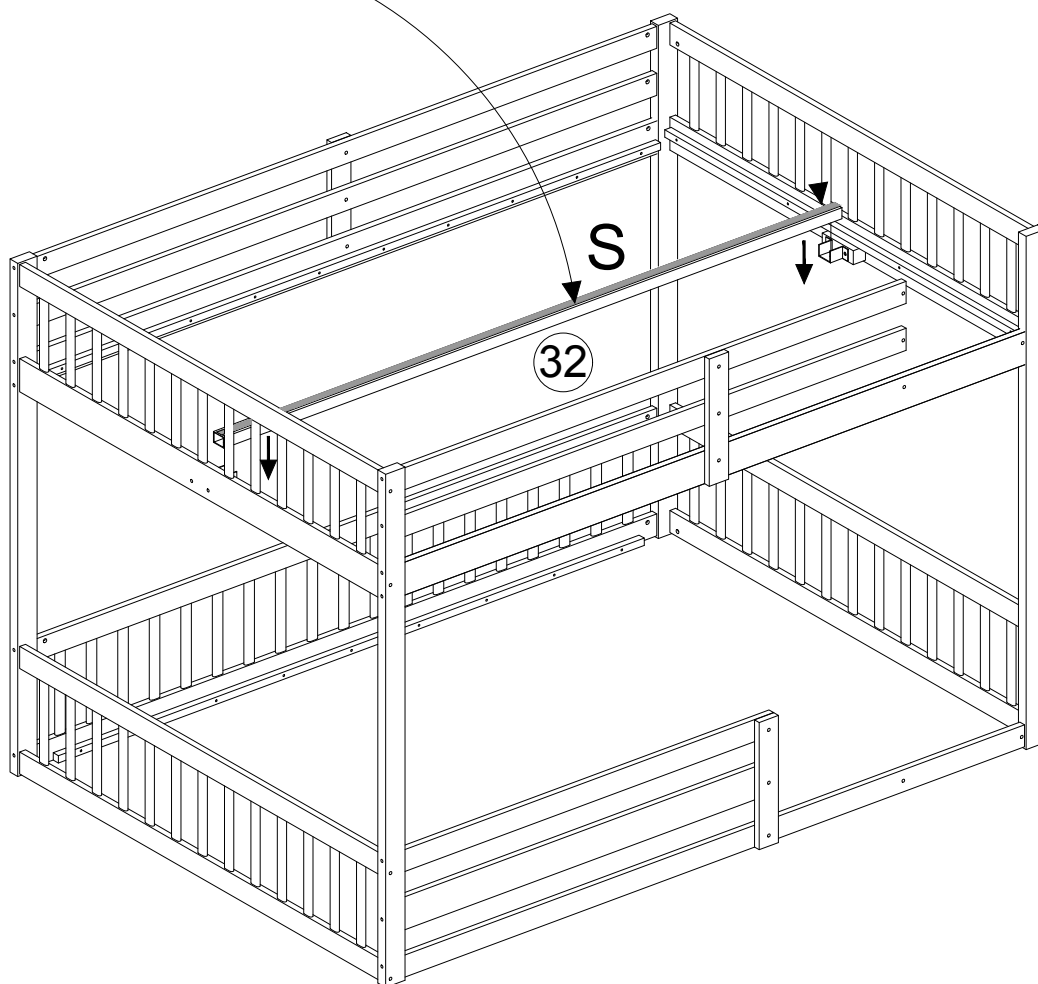
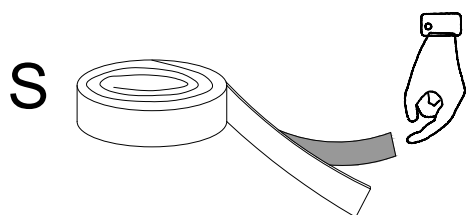

S



1PC

MONTAGEANLEITUNG/ASSEMBLY INSTRUCTIONS

9

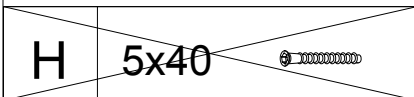
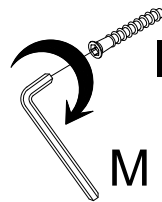
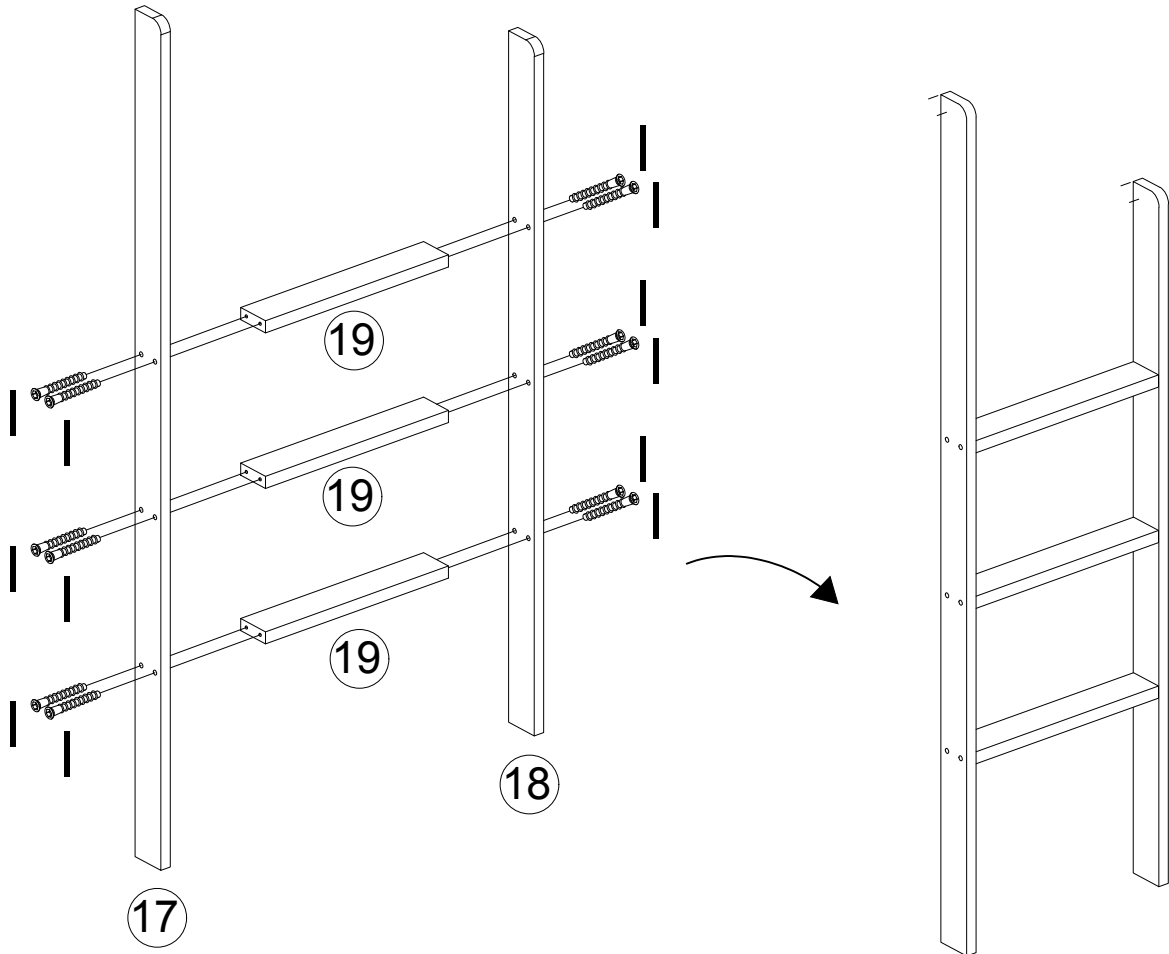

I	7x60		12PCS	M	M4		1PC
---	------	--	-------	---	----	--	-----

MONTAGEANLEITUNG/ASSEMBLY INSTRUCTIONS

10

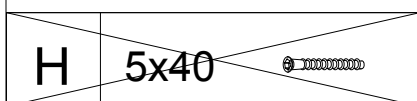
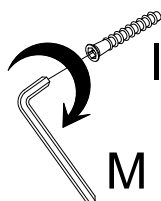
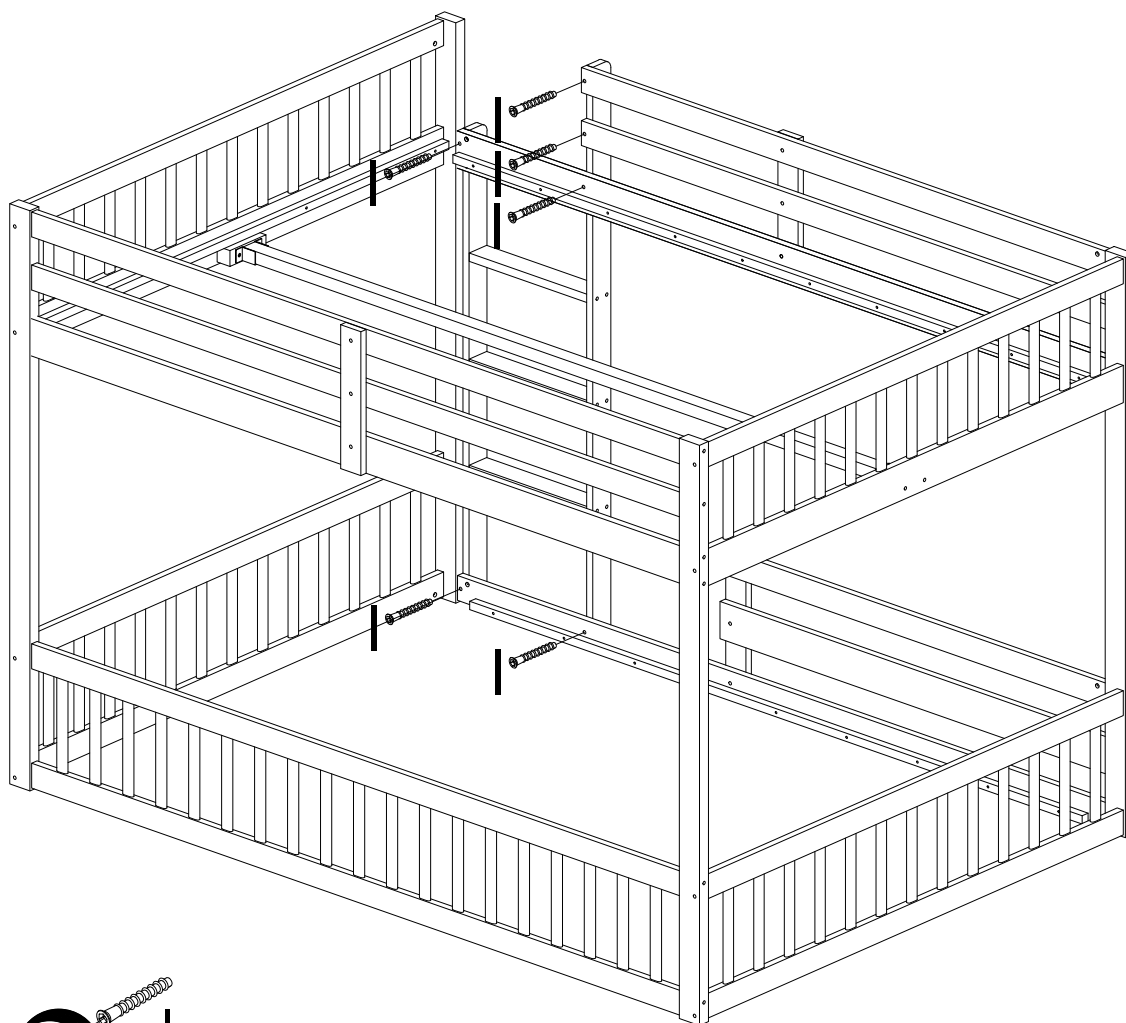



I	7x60		6PCS	M	M4		1PC
---	------	---	------	---	----	--	-----

MONTAGEANLEITUNG/ASSEMBLY INSTRUCTIONS

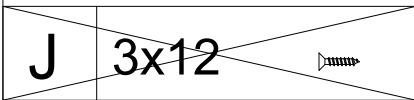
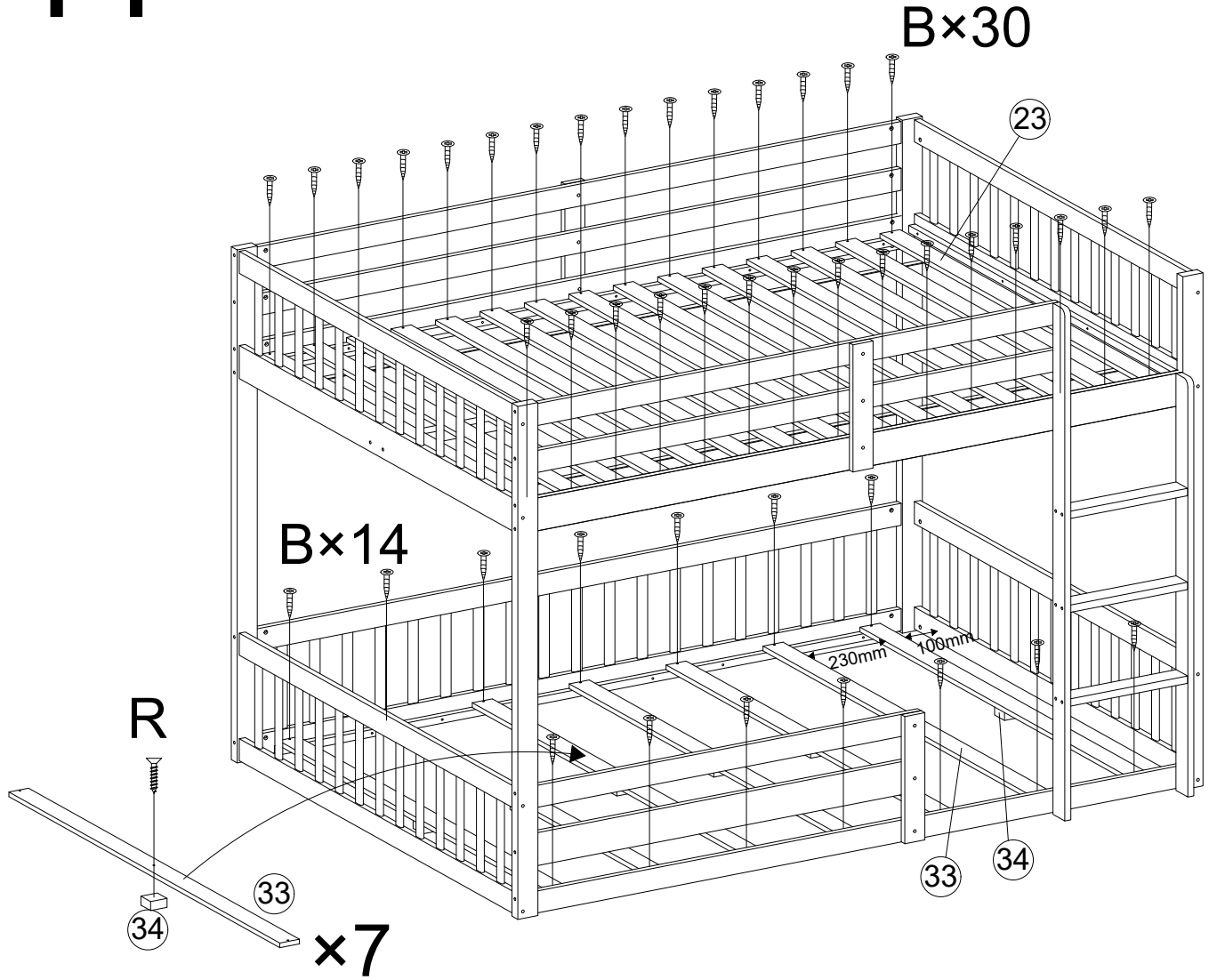
11

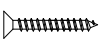



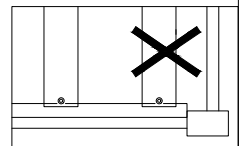
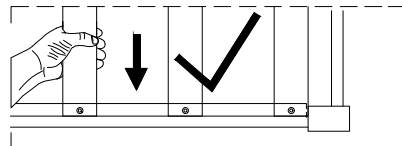

B	4x30		44PCS
R	4x35		7PCS
N			1PC

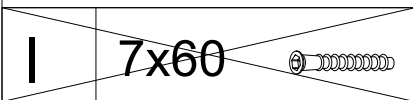
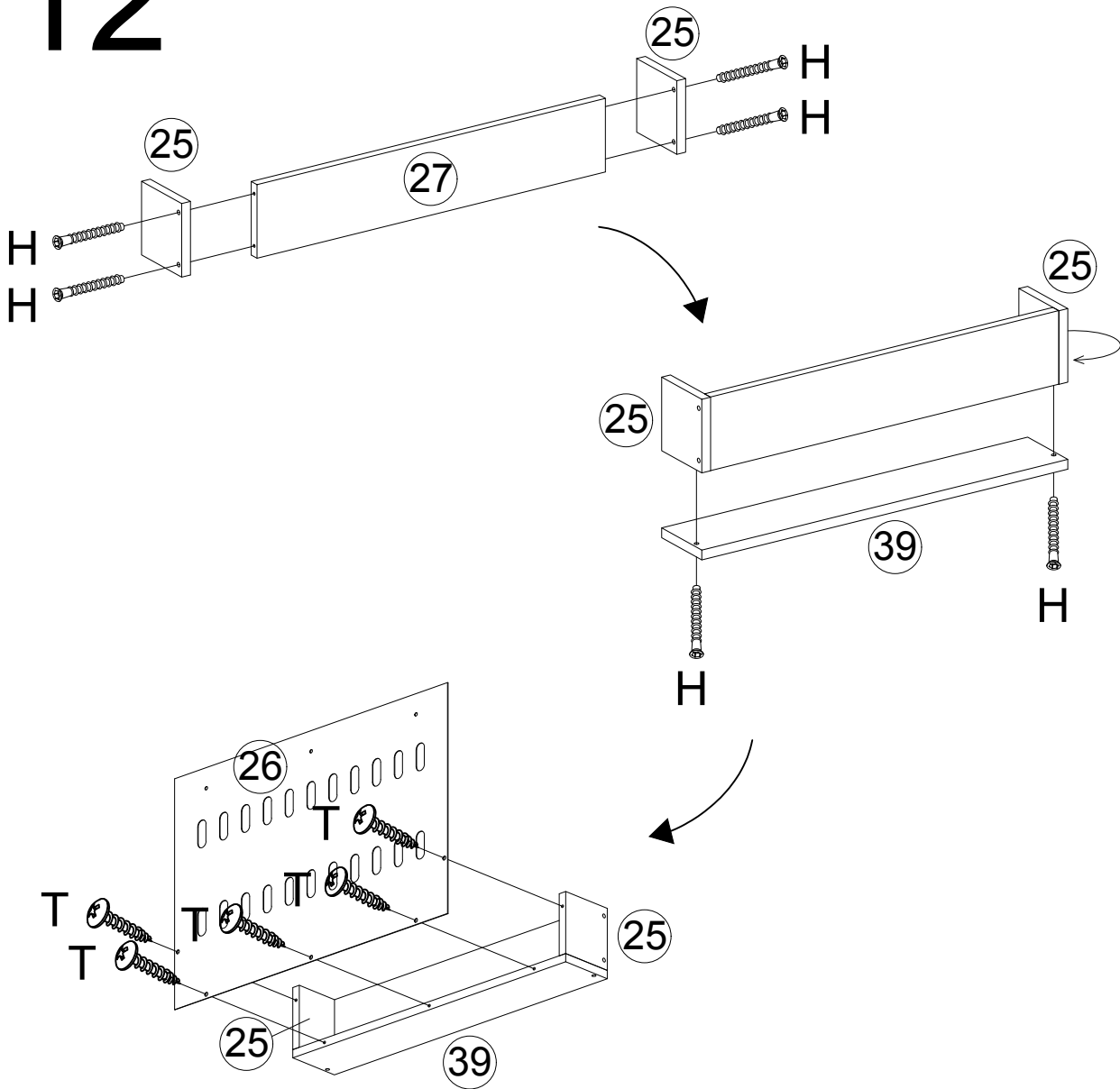

MONTAGEANLEITUNG/ASSEMBLY INSTRUCTIONS

12



H	5x40		6PCS	T	3x16		5PCS
L	M3		1PC	N			1PC

MONTAGEANLEITUNG/ASSEMBLY INSTRUCTIONS

13

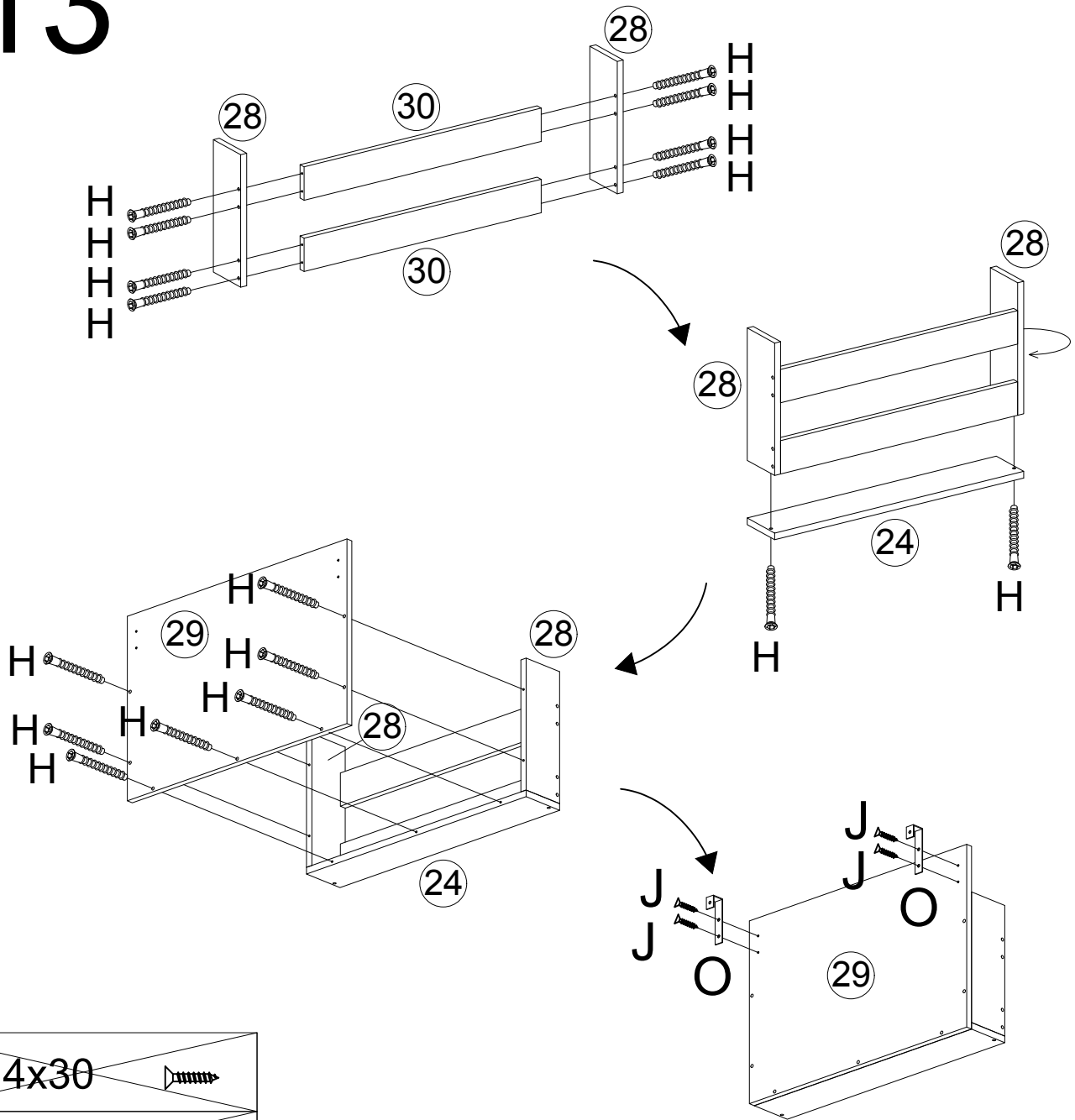



B	4x30	
R	4x35	

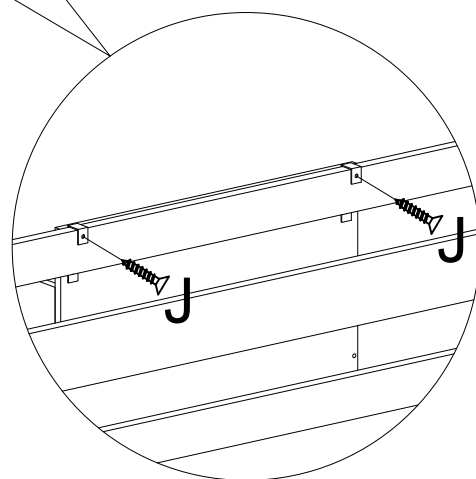
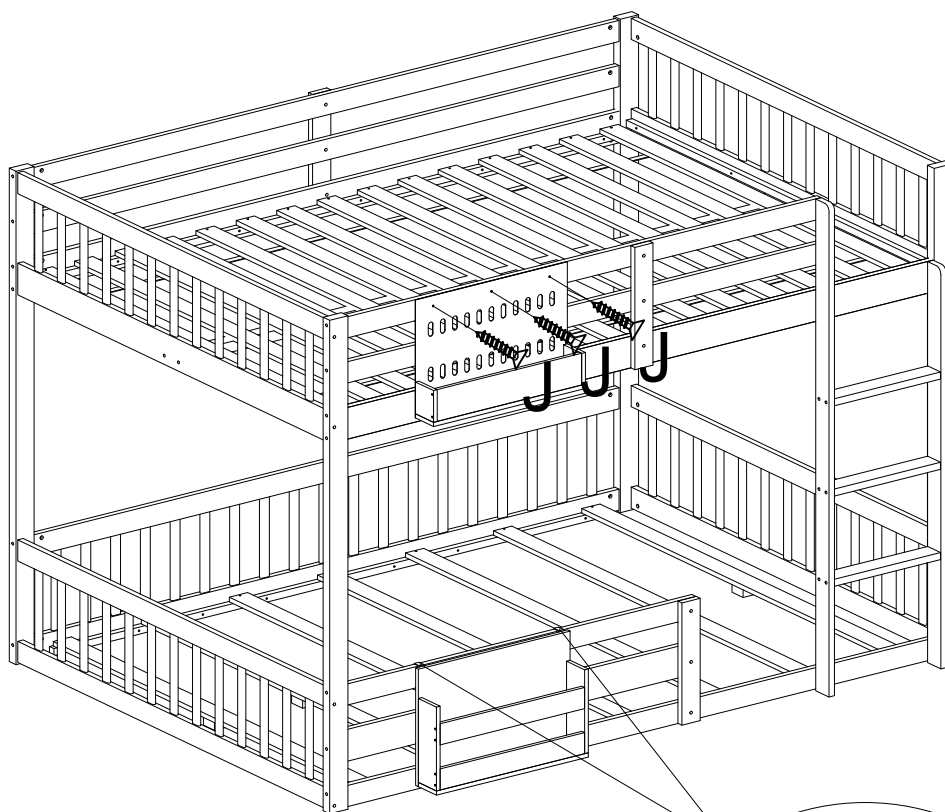

J	3x12		4PCS	I	7x60		
N			1PC	H	5x40		17PCS
O			2PCS	L	M3		1PC

MONTAGEANLEITUNG/ASSEMBLY INSTRUCTIONS

14



B	4x30	
R	4x35	

J	3x12		5PCS
N			1PC

MONTAGEANLEITUNG/ASSEMBLY INSTRUCTIONS

15

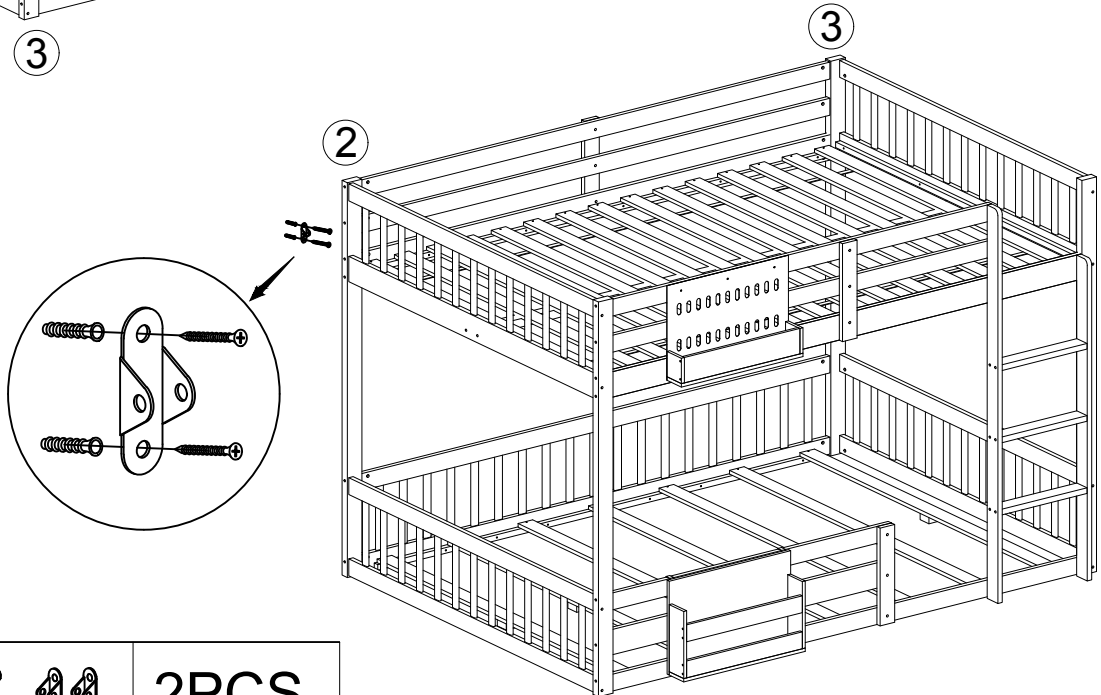
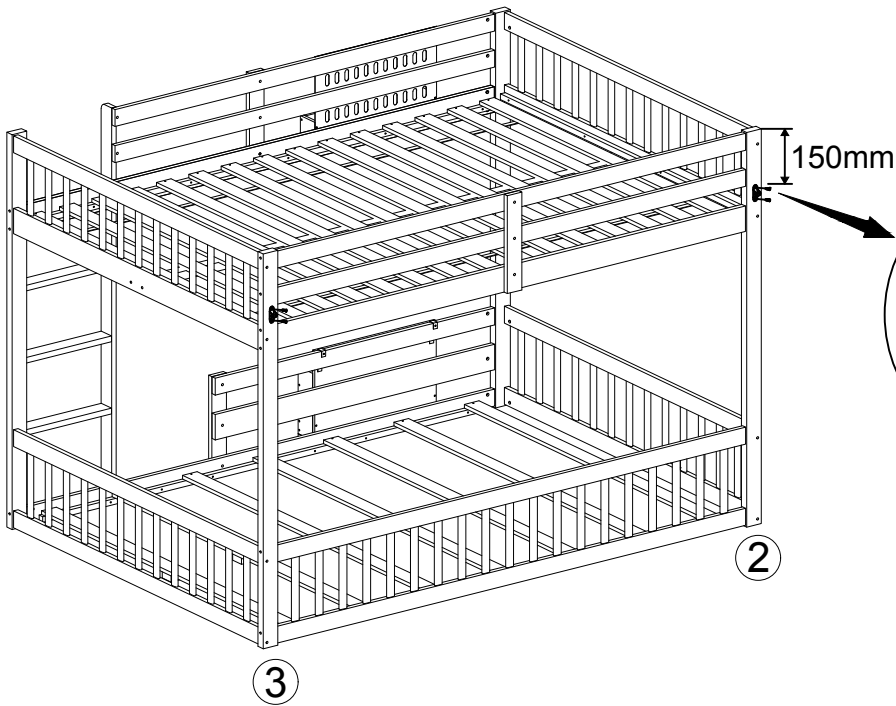
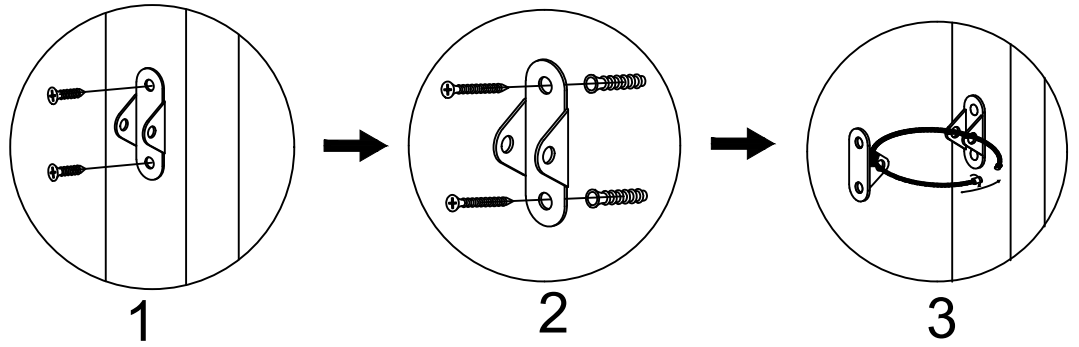

K		2PCS
N		1PC