

Please check that you have all the parts listed before you start assembling, if you do find that something is missing, do not continue assembly, please contact us immediately.

**NOTE:** Please do not completely tighten all the hardware until the entire assembly is complete!

Bitte überprüfen Sie, ob alle Teile mitgeliefert sind, bevor Sie mit der Montage beginnen. Wenn Sie festlegen, dass etwas fehlt, setzen Sie die Montage nicht fort. Bitte kontaktieren Sie uns sofort.

**Achtung :** Bitte ziehen Sie nicht alle Schrauben fest, bevor die Montage abgeschlossen ist !

<b>Importeur</b>	<b>Decobus Handel GmbH</b>
<b>Adresse</b>	<b>Innungsstraße 9,21244 Buchholz, Deutschland</b>
<b>URL</b>	<b><a href="https://www.decobusgroup.de">https://www.decobusgroup.de</a></b>
<b>Hersteller</b>	<b>XIAMEN XINKAISHENG IMPORT AND EXPORT CO.,LTD.</b>
<b>Adresse</b>	<b>RM 106 NO.62 HETONGLI HULI DISTRICT. XIAMEN CHINA</b>
<b>Email/URL</b>	<b><a href="mailto:xbt2019@126.com">xbt2019@126.com</a></b>
	<b>Decobus Handel GmbH Innungsstraße 9,21244 Buchholz, Deutschland <a href="https://www.decobusgroup.de">https://www.decobusgroup.de</a></b>

This set will be shipped by 2 boxes and they may arrive on different days.If both packages arrived but parts missing, please contact customer service.

Dieses Set ist in 2 Boxen enthalten. Wenn Sie keine vollen 2 Boxen erhalten, wenden Sie sich bitte an unseren Kundenservice

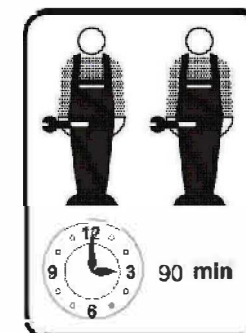

**SKU: N623P410268/N623P410269  
N623P410270**



## ANLEITUNG

### WICHTIG - SORGFÄLTIG DURCHLESEN - FÜR ZUKÜNFTIGE REFERENZ BEWAHREN

- a) **WARNUNG** Hochbetten und das Oberbett von Etagenbetten sind wegen der Verletzungsgefahr durch Stürze nicht für Kinder unter sechs Jahren geeignet.
- b) **WARNUNG**-Etagenbetten und Hochbetten können ein ernstes Verletzungsrisiko darstellen, wenn sie nicht ordnungsgemäß verwendet werden. Befestigen oder hängen Sie niemals Gegenstände an einem Teil des Etagenbetts, die nicht für die Verwendung mit dem Bett vorgesehen sind, zum Beispiel Schnüre, Kordeln, Haken, Gurte und Taschen.
- c) **WARNUNG**-Kinder können zwischen Bett und Wand eingeklemmt werden. Um die Gefahr schwerer Verletzungen zu vermeiden, darf der Abstand zwischen der oberen Sicherheitsbarriere und der angrenzenden Konstruktion 75 mm nicht überschreiten oder mehr als 230 mm betragen.
- d) **WARNUNG**-Verwenden Sie das Etagenbett/Hochbett nicht, wenn ein Bauteil beschädigt ist oder fehlt. Ersatzteile werden zwischendurch beim Hersteller oder beim Händler angefordert.
- e) Befolgen Sie unbedingt die Installationsanweisungen und die Gebrauchsanweisung des Herstellers.
- f) Die empfohlene Größe der Matratze für das Bett beträgt 200 cm x 90 cm, maximale Dicke der Matratze: 10 cm.
- g) Es ist notwendig, den Raum zu lüften, um ein niedriges Feuchtigkeitsniveau aufrechtzuerhalten und das Wachstum von Schimmel im Bett und an dessen Peripherie zu verhindern.
- h) Verbindungselemente sollten immer richtig angezogen und regelmäßig überprüft werden. Bei Bedarf festziehen.
- i) The number and year of this European Standard: "EN 747-1:2024".
- j) **WARNING** "Always ensure the platform and the ladder / stairs are permanently attached to this bunkbed before use"

## INSTRUCTIONS

### IMPORTANT - READ CAREFULLY - RETAIN FOR FUTURE REFERENCE

- a) **WARNING**-High beds and the upper bed of bunk beds are not suitable for children under six years due to the risk of injury from falls
- b) **WARNING**-Bunk beds and high beds can present a serious risk of injury from strangulation if not used correctly. Never attach or hang items to any part of the bunk bed that are not designed to be used with the bed, for example, but not limited to ropes, strings, cords, hooks, belts and bags.
- c) **WARNING**-Children can become trapped between the bed and the wall, a roof pitch, the ceiling adjoining pieces of furniture (e.g. cupboards) and the like. To avoid risk of serious injury the distance between the top safety barrier and the adjoining structure shall not exceed 75 mm or shall be more than 230 mm.
- d) **WARNING** - Do not use the bunk bed/high bed if any structural part is broken or missing; Replacement parts are between requested from the manufacturer or the store.
- e) it is imperative to always follow the installation instructions and manufacturer's use.
- f) The recommended size of the mattress to be used with the bed is 200cm x90cm, maximum thickness mattress: 10cm.
- g) It is necessary to ventilate the room in order to maintain a low level moisture and prevent mold growth in the bed and its periphery.
- h) Joining devices should always be tightened properly and regularly verified.Tighten if necessary.
- i) The number and year of this European Standard: "EN 747-1:2024".
- j) **WARNING** "Always ensure the platform and the ladder / stairs are permanently attached to this bunkbed before use"

## INSTRUCTIONS

### IMPORTANT - À LIRE ATTENTIVEMENT - CONSERVER POUR RÉFÉRENCE ULTÉRIEURE

- a) **AVERTISSEMENT** - Les lits surélevés et le lit supérieur des lits superposés ne conviennent pas aux enfants de moins de six ans en raison du risque de blessure dû à une chute;
- b) **AVERTISSEMENT** - Les lits superposés et les lits surélevés peuvent présenter un risque sérieux de blessure par strangulation s'ils ne sont pas utilisés correctement. Ne jamais attacher ou suspendre à des parties du lit superposé des objets qui ne sont pas conçus pour être utilisés avec le lit, par exemple, mais ne se limitant pas à des cordes, des ficelles, des cordes, des crochets, des ceintures et des sacs.
- c) **AVERTISSEMENT** - Les enfants peuvent rester coincés entre le lit et le mur, un toit incline les meubles adjacents au plafond (par exemple, des armoires), etc. Pour éviter tout risque de blessure grave, la distance entre la barrière de sécurité supérieure et la structure adjacente ne doit pas dépasser 75 mm ou doit être supérieure à 230 mm.
- d) **AVERTISSEMENT** - N'utilisez pas le lit superposé/ le lit surélevé si une partie de la structure est cassée ou manquante. Les pièces de rechange sont demandées au fabricant ou au magasin.
- e) il est impératif de toujours suivre les instructions d'installation et l'utilisation du fabricant.
- f) La taille recommandée du matelas à utiliser avec le lit est 200 cm x 90 cm, épaisseur maximale du matelas: 10cm.
- g) Il est nécessaire de ventiler la pièce afin de maintenir un faible niveau d'humidité et d'empêcher la formation de moisissure dans le lit et à sa périphérie.
- h) Les dispositifs de jonction doivent toujours être correctement serrés et vérifiés régulièrement. Serrer si nécessaire.
- i) The number and year of this European Standard: "EN 747-1:2024".
- j) **WARNING** "Always ensure the platform and the ladder / stairs are permanently attached to this bunkbed before use"

## ISTRUZIONI

### IMPORTANTE - LEGGERE ATTENTAMENTE - CONSERVARE IL FUTURO RIFERIMENTO

- a) **ATTENZIONE** - I letti alti e il letto superiore a castello non sono adatti a bambini di età inferiore ai sei anni a causa del rischio di lesioni da cadute;
- b) **AVVERTENZA** - I letti a castello e i letti alti possono presentare un serio rischio di lesioni a causa di strangolamento se non utilizzati correttamente. Non attaccare o appendere mai oggetti a qualsiasi parte del letto a castello che non sono progettati per essere utilizzati con il letto, ad esempio, ma non limitato a corde, corde, corde, ganci, cinture e borse.
- c) **AVVERTENZA** - I bambini possono rimanere intrappolati tra il letto e la parete, un tetto inclinato il mobile adiacente al soffitto (ad es. armadi) e simili. Per evitare il rischio di gravi lesioni, la distanza tra la barriera di sicurezza superiore e a struttura adiacente non deve superare 75 mm o deve essere superiore a 230 mm.
- d) **ATTENZIONE** - Non utilizzare il letto a castello/letto alto se qualche parte strutturale è rotta o mancante; Le parti di ricambio sono tra quelle richieste al produttore o al negozio.
- e) è indispensabile seguire sempre le istruzioni di installazione e l'uso del produttore.
- f) Le dimensioni consigliate del materasso da utilizzare con il letto sono 200 cm x 90 cm, materasso di massimo spessore: 10 cm.
- g) È necessario ventilare l'ambiente per mantenere un'umidità bassa e prevenire la formazione di muffe nel letto e nella sua periferia.
- h) I dispositivi di giunzione devono essere sempre serrati correttamente e regolarmente verificati. Stringere se necessario.
- i) The number and year of this European Standard: "EN 747-1:2024".
- j) **WARNING** "Always ensure the platform and the ladder / stairs are permanently attached to this bunkbed before use"

## INSTRUCTIES

### BELANGRIJK - LEES AANDACHTIG - BEWAAR VOOR TOEKOMSTIGE REFERENTIE

- WAARSCHUWING Hoge bedden en het bovenste bed van stapelbedden zijn niet geschikt voor kinderen jonger dan zes jaar vanwege het risico op letsel door vallen;
- WAARSCHUWING Stapelbedden en hoge bedden kunnen een ernstig risico op verwonding vormen als ze niet correct worden gebruikt. Bevestig of hang nooit items aan een deel van het stapelbed die niet zijn ontworpen voor gebruik met het bed, bijvoorbeeld, maar niet beperkt tot touwen, koorden, koorden, haken, riemen en tassen.
- WAARSCHUWING-Kinderen kunnen vast komen te zitten tussen het bed en de muur, een dakhelling het plafond aangrenzende meubels (bijv. kasten) en dergelijke. Om het risico van ernstig letsel te voorkomen, mag de afstand tussen de bovenste veiligheidsbarrière en de aangrenzende structuur niet groter zijn dan 75 mm of meer dan 230 mm.
- WAARSCHUWING-Gebruik het stapelbed/hoogbed niet als een structureel onderdeel kapot is of ontbreekt; Vervangende onderdelen worden tussen gevraagd door de fabrikant of de winkel.
- het is noodzakelijk om altijd de installatie-instructies en het gebruik van de fabrikant te volgen.
- De aanbevolen maat van de matras die met het bed wordt gebruikt, is 200 cm x 90 cm, maximale dikte matras: 10cm.
- Het is noodzakelijk om de kamer te ventileren om een laag vochtgehalte te handhaven en schimmelgroei in het bed en de periferie ervan te voorkomen.
- Verbindingsrichtingen moeten altijd goed worden vastgedraaid en regelmatig worden gecontroleerd Draai indien nodig vast.
- The number and year of this European Standard: "EN 747-1:2024".
- WARNING "Always ensure the platform and the ladder / stairs are permanently attached to this bunkbed before use"

## INSTRUKCE

### DŮLEŽITÉ PŘEČTĚTE SI POZORNĚ -UCHOVÁVAJTE PRO BUDOUCÍ REFERENCI

- VAROVÁNÍ-vysoké postele a horní lůžka palandy nejsou vhodné pro děti do šesti let z důvodu rizika zranění pádem;
- VAROVÁNÍ-Patrové postele a vysoké postele mohou představovat vážné riziko zranění při uškrcení, pokud nebudou správně použity. Nikdy nepřipevňujte ani nezavěšujte předměty na žádnou část palandy, které nejsou navrženy pro použití s postelí, ale neomezují se pouze na lana, provázky, šňůry, háčky, pásy a tašky
- VÝSTRAHA - Děti se mohou zachytit mezi postel a zed, sklonit střechu stropy přilehlé kusy nábytku (např. skříně) a podobně. Aby se zabránilo riziku vážného zranění, nesmí vzdálenost mezi horní bezpečnostní bariérou a sousední konstrukcí překročit 75 mm nebo být větší než 230 mm.
- VÝSTRAHA-Nepoužívejte patrové lůžko / vysoké lůžko, pokud je některá konstrukční část zlomená nebo chybí. Náhradní díly jsou mezi na vyžádání od výrobce nebo obchodu.
- je bezpodmínečně nutné dodržovat instalační pokyny a použití výrobce.
- Doporučená velikost matrace pro použití s postelí je 200 cm x 90 cm, maximální tloušťka matrace: 10 cm.
- Místnost je nutné ventilovat, aby se udržela nízká hladina vlhkosti a zabránilo se růstu plísní v loži a jeho obvodu..
- Spojovací zařízení by měla být vždy pevně dotažena a pravidelně ověřována, V h případě potřeby dotáhněte.
- The number and year of this European Standard: "EN 747-1:2024".
- WARNING "Always ensure the platform and the ladder / stairs are permanently attached to this bunkbed before use"

## IINSTRUKCJE

### WAŻNE - PRZECZYTAJ UWAGA -ZACHOWAJ NAPRZYSZŁOŚĆ

- OSTRZEŻENIE Wysokie łóżka i górne łóżko łóżek piętrowych nie są odpowiednie dla dzieci poniżej sześciu lat ze względu na ryzyko obrażeń w wyniku upadku;
- OSTRZEŻENIE - Łóżka piętrowe i wysokie łóżka mogą stwarzać poważne ryzyko obrażeń na skutek uduszenia, jeśli nie zostaną właściwie użyte. Nigdy nie mocuj ani nie wieszaj przedmiotów na żadnej części łóżka piętrowego, które nie są przeznaczone do użytku z łóżkiem, na przykład, ale nie ograniczając się do lin, sznurków, sznurków, haczyków, pasów i toreb.
- nachyleniem dachu pod sufitem przylegającymi meblami (np. szafkami) i tym podobne.
- Aby uniknąć ryzyka poważnych obrażeń, odległość między górną barierą bezpieczeństwa a przylegającą konstrukcją nie może przekraczać 75 mm lub być większa niż 230mm. OSTRZEŻENIE - Dzieci mogą zostać uwięzione między łóżkiem a ścianą,
- OSTRZEŻENIE - Nie używaj łóżka piętrowego/wysokiego łóżka, jeśli jakkolwiek część konstrukcyjna jest zepsuta lub brakuje jej; Części zamienne są wymagane od producenta lub sklepu.
- bezwzględnie należy przestrzegać instrukcji instalacji i użytkowania producenta.
- Zalecany rozmiar materaca do zastosowania z łóżkiem to 200 cm x 90 cm, maksymalna grubość materaca: 10cm.
- Konieczna jest wentylacja pomieszczenia w celu utrzymania niskiego poziomu wilgoci i zapobiegania rozwojowi pleśni w łóżku i jego obrzeżach.
- Urządzenia łączące powinny być zawsze odpowiednio dokręcone i regularnie sprawdzane. Dokręcić w razie potrzeby.
- The number and year of this European Standard: "EN 747-1:2024".
- WARNING "Always ensure the platform and the ladder / stairs are permanently attached to this bunkbed before use"

## INŠTRUKCIE

### DŔLEŽITÉ - POZORNE SI PREČĪTAJTE -UCHOVÁVAJTE PRE BUDŮCE REFERENCIE

- VÝSTRAHA-Vysoké postele a horné postele poschodových posteli nie sú vhodné pre deti do šiestich rokov kvôli riziku zranenia pádom;
- VÝSTRAHA-poschodové postele a vysoké postele môžu predstavovať vážne riziko zranenia priškrtením, ak sa nebudú správne používať. Nikdy nepřipevňujte ani nevešajte predmety k žiadnej časti poschodovej postele, ktorá nie je určená na použitie s postelou, napríklad, ale nielen, laná, šnúry, šnúry, háčiky, pásy a tašky,
- VÝSTRAHA-Deti sa môžu zachytiť medzi postelou a stenou, sklonom strechy, stropom priliehajúcim kusy nábytku (napr. skrinky) a podobne. Aby sa predišlo riziku vážneho zranenia, vzdialenosť medzi hornou bezpečnostnou bariérou a príslušnou konštrukciou nesmie prekročiť 75 mm alebo byť viac ako 230 mm.
- VÝSTRAHA-Nepoužívajte poschodovú postel/vysoké lóžko, ak je akákoľvek konštrukčná časť poškodená alebo chýba: Náhradné diely sú potrebné na vyžiadanie od výrobcu alebo skladu.
- je bezpodmínečne nutné postupovať podľa pokynov na inštaláciu a podľa pokynov výrobcu.
- Odporúčaná veľkosť matrace použitého na lóžko je 200 cm x 90 cm, maximálna hrúbka matrace: 10 cm.
- Miestnosť je potrebné vetrať, aby sa udržala nízka úroveň vlhkosti a zabránilo sa rastu plesní v lóžku a jeho obvode.
- Spojovacie zariadenia by sa mali vždy pevne dotiahnuť a pravidelne preverovať. V prípade potreby dotiahnite.
- The number and year of this European Standard: "EN 747-1:2024".
- WARNING "Always ensure the platform and the ladder / stairs are permanently attached to this bunkbed before use"

## UTASÍTÁS

**FONTOS - OLVASSA EL FIGYELMESEN**

**-VÁRJON A JÖVŐBEN**

- VIGYÁZAT A magas ágyak és az emeletes ágyak felső ágya nem alkalmas hat év alatti gyermekek számára az esések sérülésének veszélye miatt ;
- FIGYELMEZTETÉS - Az emeletes ágyak és a magas ágyak súlyos sérülést okozhatnak a főtámaszok következtében, ha nem használják helyesen. Soha ne csatlakoztasson és ne légyon az emeletes ágy olyan részeire, amelyeket például nem az ágyhoz való felhasználásra terveztek, de ezekre nem korlátozódnak: kötelek, húrok, zsinórok, horgok, övek és táskák.
- FIGYELMEZTETÉS - A gyermekek becsapódhatnak az ágy és a fal közé, tetőtéri a mennyezetet a szomszédos bútorokhoz (például szekrényekhez) és hasonlókat. A súlyos sérülés kockázatának elkerülésére érdekében a felső biztonsági akadály és a szomszédos szerkezet közötti távolság nem haladhatja meg a 75 mm-t vagy több, mint 230 mm.
- FIGYELMEZTETÉS Ne használja az emeletes ágyat/magas ágyat, ha valamelyik szerkezeti elem törött vagy hiányzik; A cserealkatrészeket a gyártótól vagy a bolttól kérheti.
- feltétlenül kövesse a telepítési utasításokat és a gyártó általi felhasználást.
- Az ágyhoz használni kívánt matrac ajánlott mérete 200 cm x 90 cm, a matrac maximális vastagsága: 10 cm.
- Szellőztetni kell a helyiséget, hogy fennmaradjon az alacsony nedvességtartalom, és megakadályozzák a penész növekedését az ágyban és annak peremén.
- A csatlakozóberendezéseket mindig megfelelően meg kell hűzni és rendszeresen ellenőrizni kell. Szükség esetén húzza meg.
- The number and year of this European Standard: "EN 747-1:2024".
- WARNING "Always ensure the platform and the ladder / stairs are permanently attached to this bunkbed before use"

## TALÍMATLAR

**ÖNEMLİ - DİKKATLE OKUYUN - GELECEK**

**REFERANS İCİN TUTUN**

- UYARI Yüksek yataklar ve ranzaların üst yatağı, düşme nedeniyle yaralanma tehlikesi nedeniyle altı yaşın altındaki çocuklar için uygun değildir,
- UYARI- Ranzalar ve yüksek yataklar, doğru kullanılmadığı takdirde boğulma nedeniyle ciddi yaralanma riski oluşturabilir. Hiçbir zaman ranza yatağının, yatakla birlikte kullanılmak üzere tasarlanmamış, ancak ipler, ipler, kordonlar, kancalar, kayışlar ve çantalar ile sınırlı olmamak üzere herhangi bir parçasına takmayın veya asılmayın.
- UYARI-Çocuklar yatakla duvar arasında sıkışıp kalabilir, tavana bitişik mobilya parçaları (örneğin dolaplar) ve benzeri bir tavan döşenir. Ciddi yaralanma riskini önlemek için üst güvenlik bariyeri ve bitişik yapı arasındaki mesafe 75 mm'yi geçmemelidir veya 230 mm'den fazla olmalıdır,
- UYARI-Herhangi bir yapısal parça kırılmış veya eksiğe ranza/yüksek yatak kullanmayın; Yedek parçalar üretici veya mağazadan talep arasındadır.
- her zaman kurulum talimatlarını ve üreticinin kullanımını takip etmek zorunludur.
- Yatak ile birlikte kullanılması tavsiye edilen yatak boyutu 200 cm x 90 cm, maksimum kalınlık yatağı: 10 cm'dir.
- Düşük seviyede nem sağlamak ve yatak ve çevresinde küf oluşumunu önlemek için odanın havalandırılması gerekir.
- Birleştirme cihazları her zaman uygun şekilde sıkılmalı ve düzenli olarak kontrol edilmelidir. Gerekirse sıkın.
- The number and year of this European Standard: "EN 747-1:2024".
- WARNING "Always ensure the platform and the ladder / stairs are permanently attached to this bunkbed before use"

## INSTRUCȚIUNI

**IMPORTANT - CITITI CU ATENȚIE - PATITI**

**PENTRU REFERINȚĂ VIITORĂ**

- AVERTIZARE Paturile înalte și patul superior al paturilor nu sunt potrivite
- AVERTIZARE - Paturile suprapuse și paturile înalte pot prezenta un risc grav de rănire din cauza strangularii dacă nu sunt utilizate corect. Nu atașați și nu agățați niciodată articole pe nicio parte a patului care nu sunt concepute pentru a fi utilizate cu patul, de exemplu, dar fără a se limita la frânghii, corzi, snururi, cârlige, curele și saci.
- AVERTIZARE Copiii pot deveni prinși între pat și perete, pot acoperi acoperișul pe piesele de mobilier alăturate (de ex. dulapuri) și altele asemenea. Pentru a evita riscul de rănire gravă, distanța dintre bariera de siguranță superioară și structura alăturată nu trebuie să depășească 75 mm sau să fie mai mare de 230 mm.
- AVERTIZARE - Nu folosiți patul supraetajat /patul înalt dacă o parte structurală este ruptă sau lipsește; Piesele de schimb se fac între solicitarea producătorului sau a magazinului.
- este obligatoriu să respectați întotdeauna instrucțiunile de instalare și utilizarea producătorului.
- Dimensiunea recomandată a saltelei care va fi folosită cu patul este de 200cm x 90cm, grosimea maximă a saltelei: 10 cm.
- Este necesară ventilarea camerei pentru a menține o umiditate la nivel scăzut și a preveni creșterea mușcăiului în pat și la periferia acesteia.
- Dispozițiile de îmbinare trebuie întinse întotdeauna corect și verificate regulat. Strângeți dacă este necesar,
- The number and year of this European Standard: "EN 747-1:2024".
- WARNING "Always ensure the platform and the ladder / stairs are permanently attached to this bunkbed before use"

## ИНСТРУКЦИИ

**ВАЖНО ПРОЧИТАЙТЕ ВНИМАТЕЛЬНО**

**-СОХРАНИТЕ БУДУЩУЮ ССЫЛКУ**

- ПРЕДУПРЕЖДЕНИЕ Высокие кровати и верхняя кровать двухъярусных кроватей не подходит для детей младше шести из-за риска получения травмы в результате падения;
- ПРЕДУПРЕЖДЕНИЕ двухъярусные кровати и высокие кровати могут представлять серьезную опасность травмирования от удушья, неправильно использовать. Никогда не прикрепляйте и не подвешивайте предметы к какой-либо части двухъярусной кровати, например, которые не предназначены для использования с кроватью, но не ограничиваются веревками, веревками, шнурами, крючками, ремнями и сумками.
- ПРЕДУПРЕЖДЕНИЕ Дети могут оказаться в ловушке между кроватью и стеной, крышей, наклонить потолок к смежным предметам мебели (например, шкафам) и т.п. Во избежание риска получения серьезных травм расстояние между верхним защитным барьером и прилегающей конструкцией не должно превышать 75 мм или должно быть более 230 мм.
- ПРЕДУПРЕЖДЕНИЕ не используйте двухъярусную кровать /высокую кровать, если какая-либо конструктивная часть сломана или отсутствует; Запасные части между запросами от производителя или магазина.
- обязательно всегда следовать инструкциям по установке и использованию изготовителем.
- Рекомендуемый размер матраса, который будет использоваться с кроватью, составляет 200 см x 90 см, максимальная толщина матраса: 10
- Необходимо проветривать помещение, чтобы поддерживать низкий уровень влаги и предотвращать образование плесени в ложе и на его периферии.
- Соединительные устройства всегда должны быть надежно затянуты и регулярно проверяться. Затянуть при необходимости.
- The number and year of this European Standard: "EN 747-1:2024".
- WARNING "Always ensure the platform and the ladder / stairs are permanently attached to this bunkbed before use"

**English**

**English IMPORTANT ! KEEP FOR FUTURE REFERENCE: READ CAREFULLY**

- To be assembled by an adult. Assembly must be checked by an adult before use
- WARNING | Keep all screws, small parts and plastic bags out of the reach of children
- Properly identify all parts before assembling
- Never use your item if any of its parts are broken or missing
- Should any problems arise, please contact our After Sales Service
- Manufacturer's instructions shall be followed at all times
- Care: Clean with a soft, dry cloth. In case of larger stains, carefully rub with a slightly damp, non- abrasive sponge
- Avoid the risk of fire by not placing furniture near sources of ignition or hot items
- Do not jump on the bed

**Deutsch**

**WICHTIG ! ZUM SPÄTEREN NACHSCHLAGEN AUFBEWAHREN: SORGFÄLTIG LESEN**

- Muss von einem Erwachsenen zusammengebaut werden. Der Zusammenbau muss vor dem Gebrauch von einem . Erwachsenen überprüft werden
- WARNUNG! Bewahren Sie alle Schrauben, Kleinteile und Plastikbeutel außerhalb der Reichweite von Kindern auf
- Kennzeichnen Sie vor dem Zusammenbau alle Teile richtig
- Benutzen Sie Ihren Artikel niemals, wenn Teile gebrochen sind oder fehlen
- Sollten Probleme auftreten, wenden Sie sich bitte an unseren Kundendienst
- Die Anweisungen des Herstellers sind stets zu befolgen
- Pflege: Mit einem weichen, trockenen Tuch reinigen. Bei größeren Flecken vorsichtig mit einem leicht feuchten, nicht scheuernden Schwamm abreiben, nicht scheuernden Schwamm Vermeiden Sie die Gefahr eines .
- Brandes, indem Sie die Möbel nicht in der Nähe von Zündquellen oder heißen Gegenständen aufstellen
- Nicht auf das Bett springen

**Français**

**IMPORTANT ! CONSERVER POUR RÉFÉRENCE ULTÉRIEURE: LIRE ATTENTIVEMENT**

- Le montage doit être effectué par un adulte. Le montage doit être vérifié par un adulte avant Utilisation
- ATTENTION! Tenir les vis, les petites pièces et les sachets en plastique hors de portée des enfants Identifiez correctement toutes les pièces avant de les assembler
- N'utilisez jamais votre article si l'une de ses pièces est cassée ou manquante
- En cas de problème, veuillez contacter notre service après-vente
- Les instructions du fabricant doivent être respectées à tout moment
- Entretien: nettoyer avec un chiffon doux et sec. En cas de taches plus importantes, frotter soigneusement avec une éponge non abrasive légèrement humide, légèrement humide et non Abrasive
- Évitez les risques d'incendie en ne plaçant pas les meubles à proximité de sources d'inflammation ou d'objets chauds
- Ne pas sauter sur le lit

**Italiano**

**IMPORTANTE ! CONSERVARE PER RIFERIMENTO FUTURO: LEGGERE ATTENTAMENTE**

- Deve essere assemblato da un adulto. L'assemblaggio deve essere controllato da un adulto prima dell'uso **IMPORTANTE! CONSERVARE PER RIFERIMENTO FUTURO: LEGGERE ATTENTAMENTE**
- ATTENZIONE! Tenere tutte le viti, le piccole parti e i sacchetti di plastica fuori dalla portata dei bambini Identificare correttamente tutte le parti prima dell'assemblaggio
- Non utilizzare mai l'articolo se alcune parti sono rotte o mancanti
- In caso di problemi, si prega di contattare il nostro Servizio Post Vendita
- Le istruzioni del produttore devono essere sempre seguite  
Cura: Pulire con un panno morbido e asciutto. In caso di macchie più estese, strofinare accuratamente con una spugna leggermente umida e nonspugna leggermente umida e non abrasiva
- Evitare il rischio di incendio, non collocando i mobili vicino a fonti di accensione o a oggetti caldi
- Non saltare sul letto

- Debe ser montado por un adulto. El montaje debe ser comprobado por un adulto antes del uso
- **ADVERTENCIA** Mantenga todos los tornillos, piezas pequeñas y bolsas de plástico fuera del alcance de los niños.
- Identifique correctamente todas las piezas antes de montarlas
- Nunca utilice su artículo si alguna de sus piezas está rota o falta
- Si surge algún problema, póngase en contacto con nuestro Servicio Postventa
- Las instrucciones del fabricante deben seguirse en todo momento
- Cuidado: Limpiar con un paño suave y seco. En caso de manchas más grandes, frote cuidadosamente con una esponja no abrasiva ligeramente humedecida.
- Evite el riesgo de incendio no colocando los muebles cerca de fuentes de ignición u objetos calientes.
- No saltar sobre la cama.

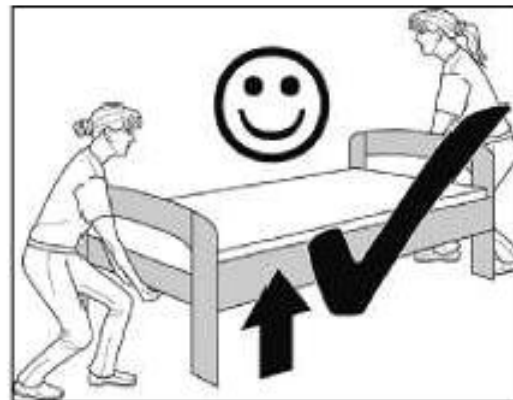
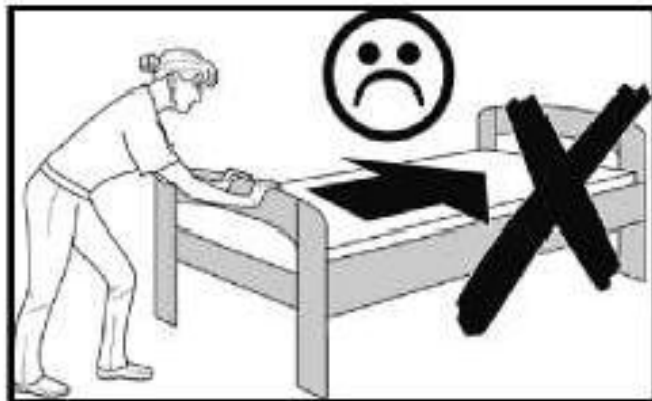





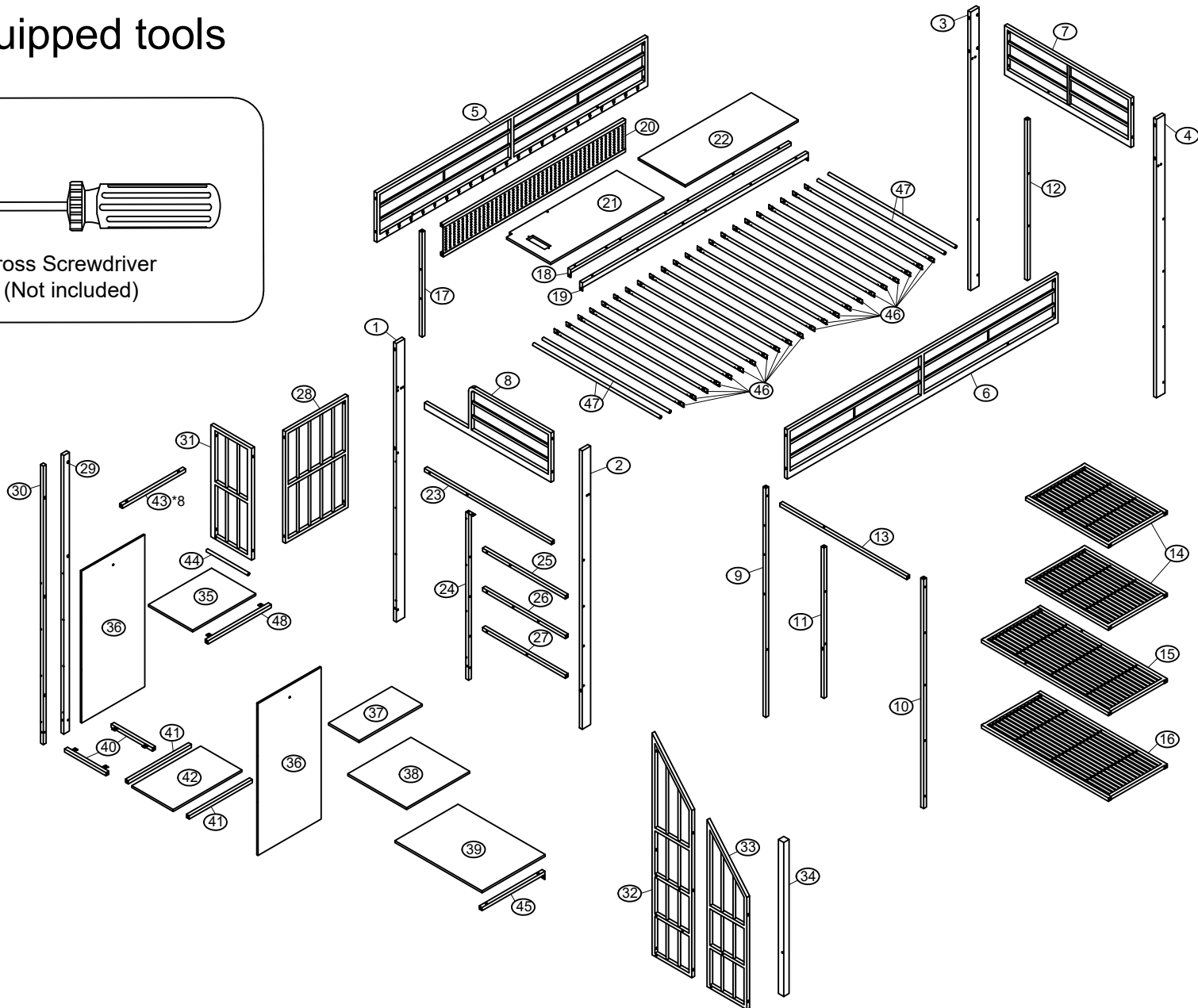
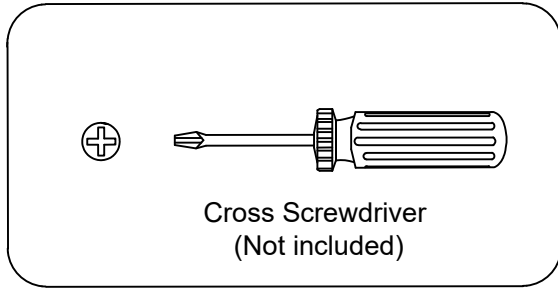



# Montageanleitung für Bettgestell

## Self equipped tools

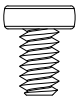
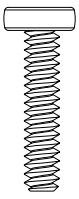
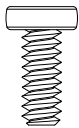
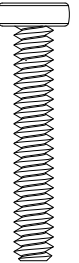
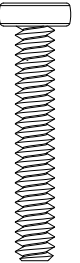
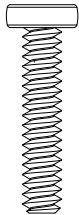

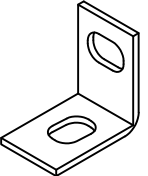
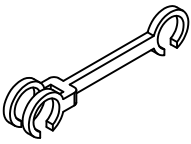

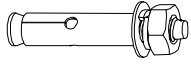

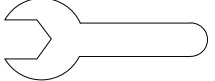





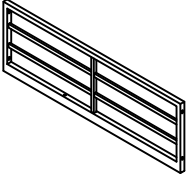
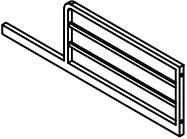

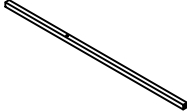
# Montageanleitung für Bettgestell

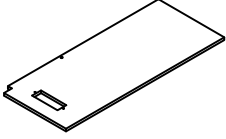
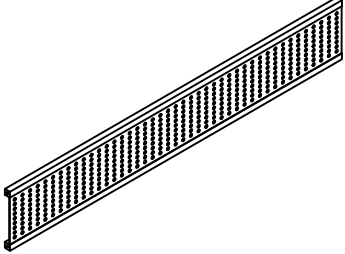
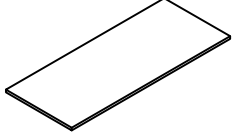
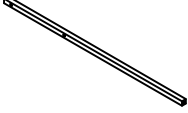
Hardware parts Hardware-Teile SKU N623P410268

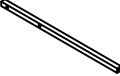
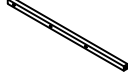
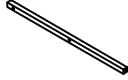
<p>(A) x 4</p>  <p>Ø5 x 58mm</p>	<p>(B) x 8</p>  <p>Ø5 x 38mm</p>	<p>(C) x 6</p>  <p>Ø1/4" x 11mm</p>	<p>(D) x 26</p>  <p>Ø1/4" x 28mm</p>	<p>(E) x 5</p>  <p>Ø1/4" x 14mm</p>	<p>(F) x 7</p>  <p>Ø1/4" x 60mm</p>	<p>(G) x 1</p>  <p>Ø1/4" x 83mm</p>
<p>(H) x 104</p>  <p>Ø1/4" x 38mm</p>	<p>(I) x 1</p>  <p>M3</p>	<p>(J) x 1</p>  <p>M4</p>	<p>(K) x 2</p> 	<p>(M) x 25</p> 	<p>(N) x 1</p> 	<p>(O) x 2</p>  <p>Ø4 x 12mm</p>
<p>(Q) x 2</p> 	<p>(R) x 4</p>  <p>Ø4 x 80mm</p>	<p>(S) x 1</p> 	<p>(T) x 1</p> 			

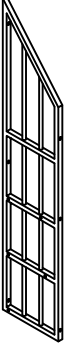
# Montageanleitung für Bettgestell

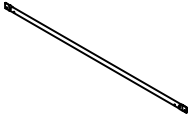
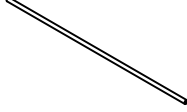
Hardware parts Hardware-Teile SKU N623P410268

⑦ x1 	⑧ x1 	⑪ x1 	⑫ x1 	⑬ x1 	⑰ x1 	⑳ x1 
⑳ x1 	㉒ x1 	㉓ x1 	㉔ x1 	㉕ x1 	㉖ x1 	㉗ x1 
㉑ x1 	㉒ x1 	㉓ x1 	④⑥ x22 	④⑦ x4 	L x 44 	P x 1 





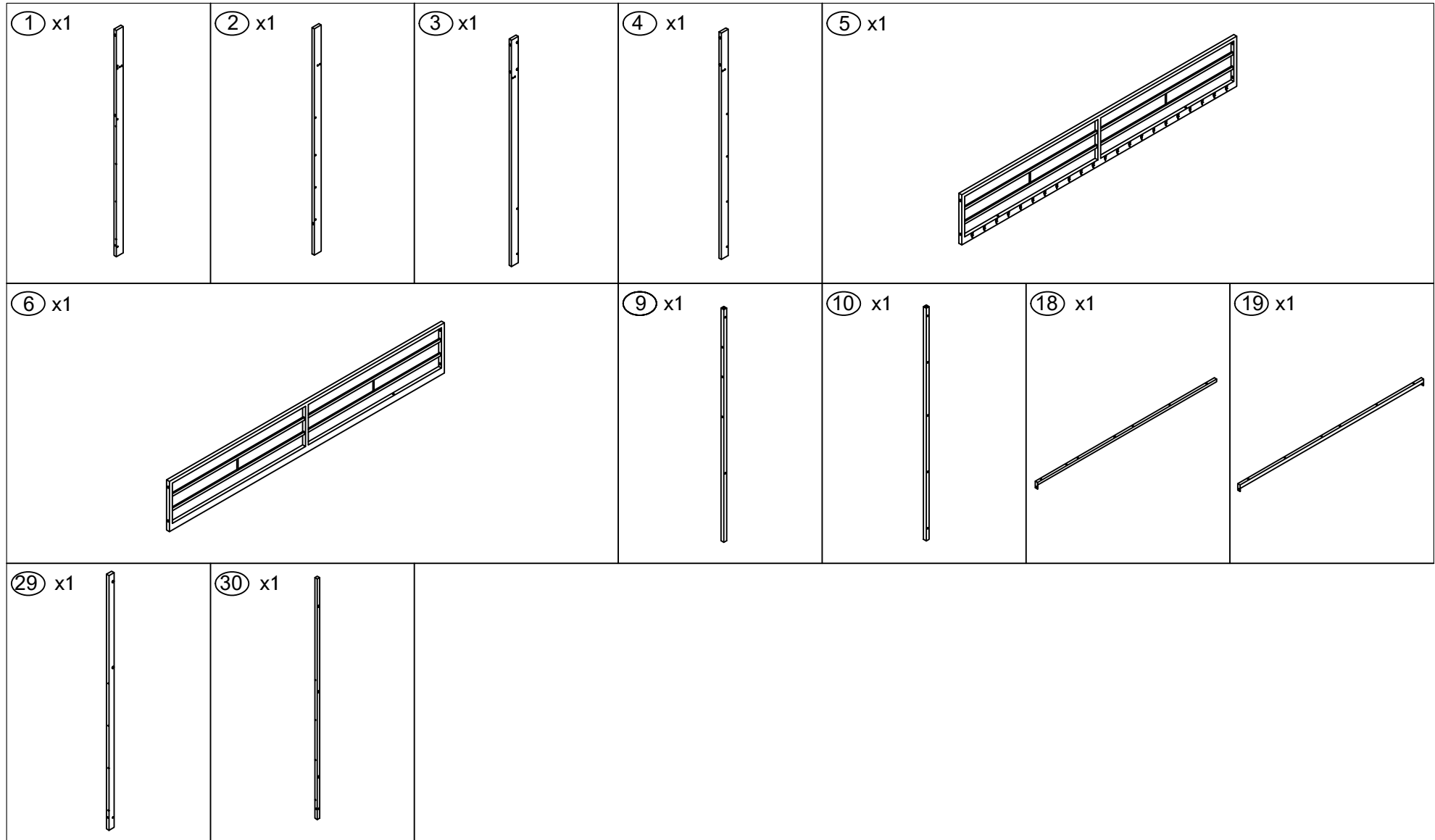

# Montageanleitung für Bettgestell

Hardware parts Hardware-Teile SKU N623P410269

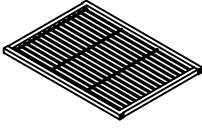
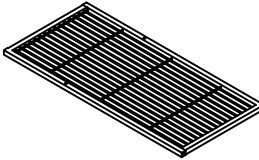
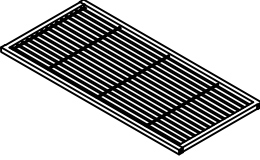
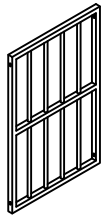

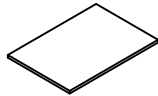
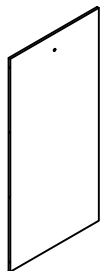
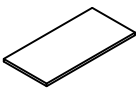
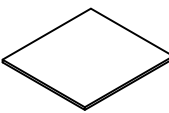
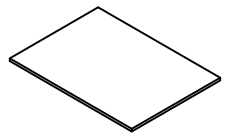
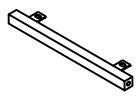
# Montageanleitung für Bettgestell

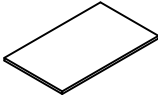
Hardware parts Hardware-Teile SKU N623P410270

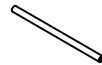
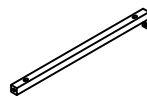
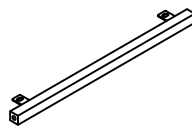
<p>⑭ x2</p> 	<p>⑮ x1</p> 	<p>⑯ x1</p> 	<p>⑳ x1</p> 	<p>㉓ x1</p> 	<p>㉔ x1</p> 	<p>㉕ x2</p> 
<p>㉗ x1</p> 	<p>㉘ x1</p> 	<p>㉙ x1</p> 	<p>㉚ x2</p> 	<p>㉛ x2</p> 	<p>㉜ x1</p> 	<p>㉝ x8</p> 
<p>㉞ x1</p> 	<p>㉟ x1</p> 	<p>㊱ x1</p> 				

# Montageanleitung für Bettgestell

## STEP 1

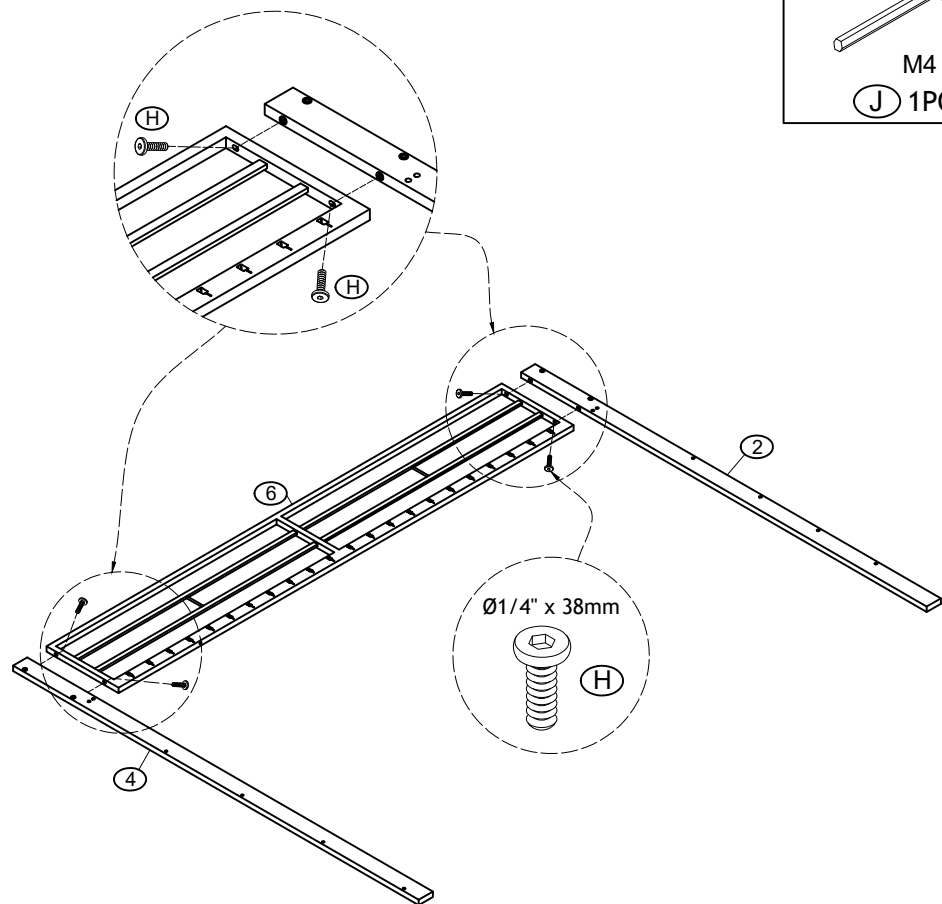
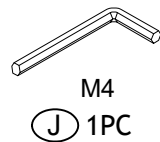
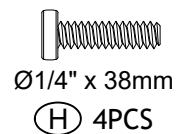

## STEP 2

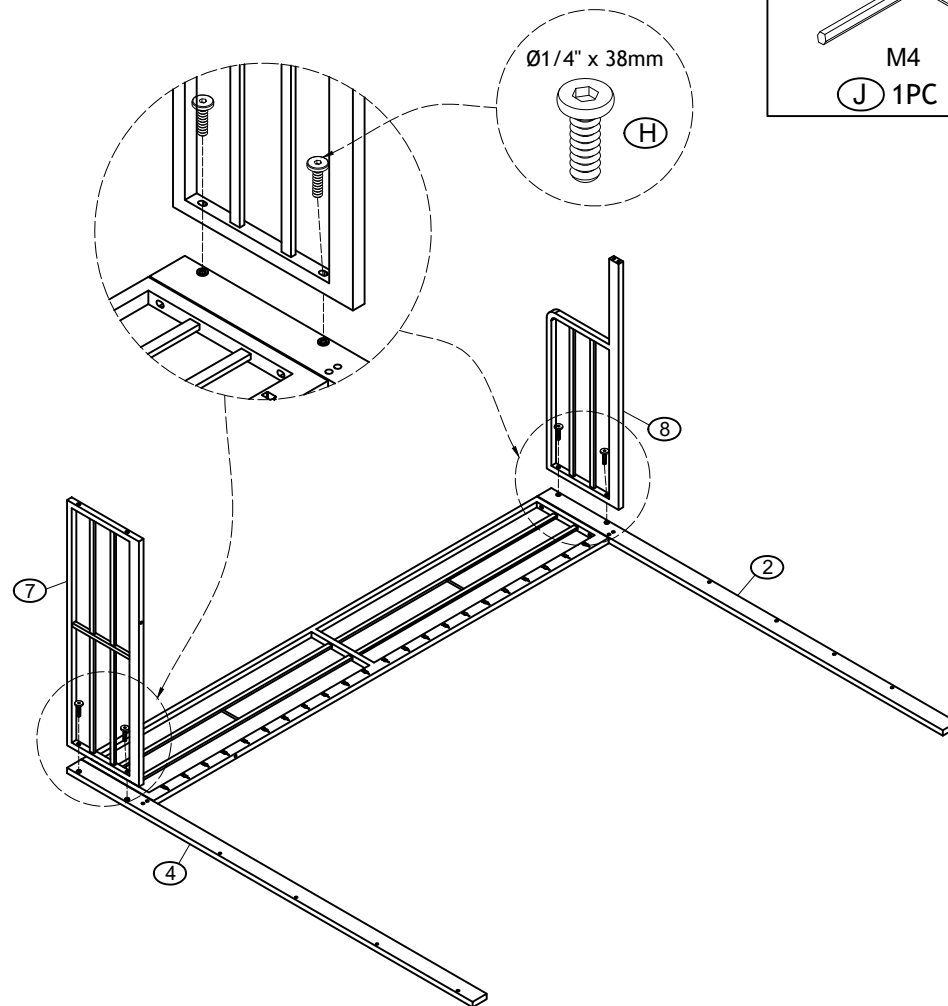
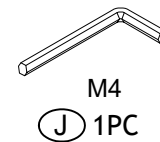
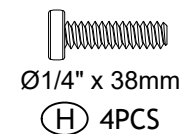

# Montageanleitung für Bettgestell

## STEP 3

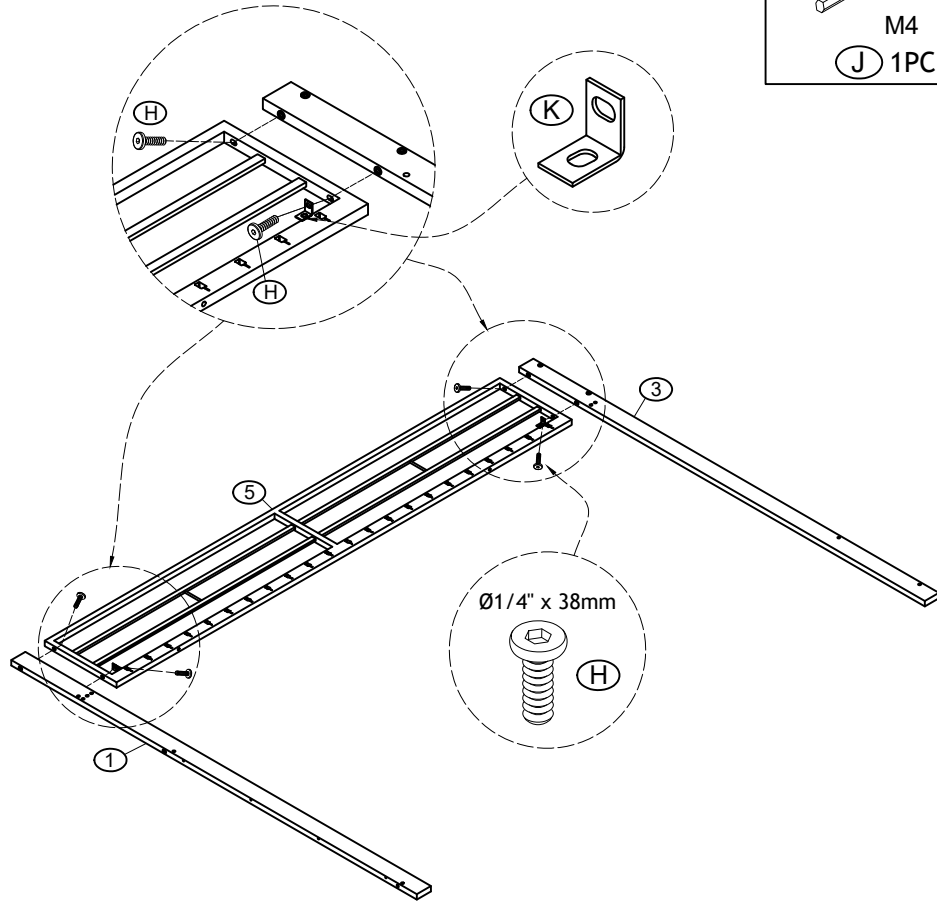
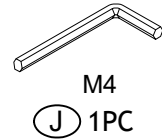
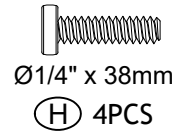
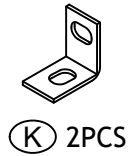

## STEP 4

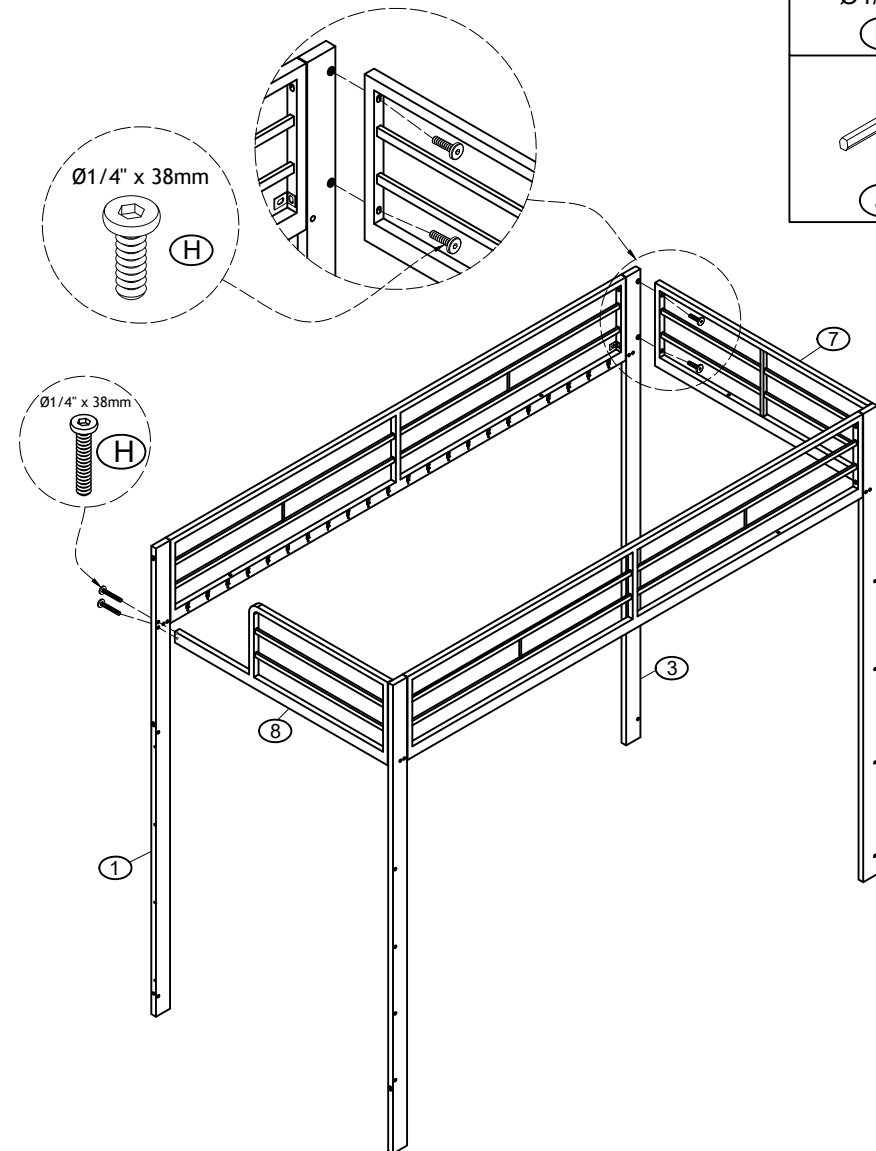
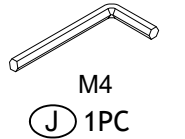
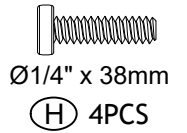

# Montageanleitung für Bettgestell

## STEP 5

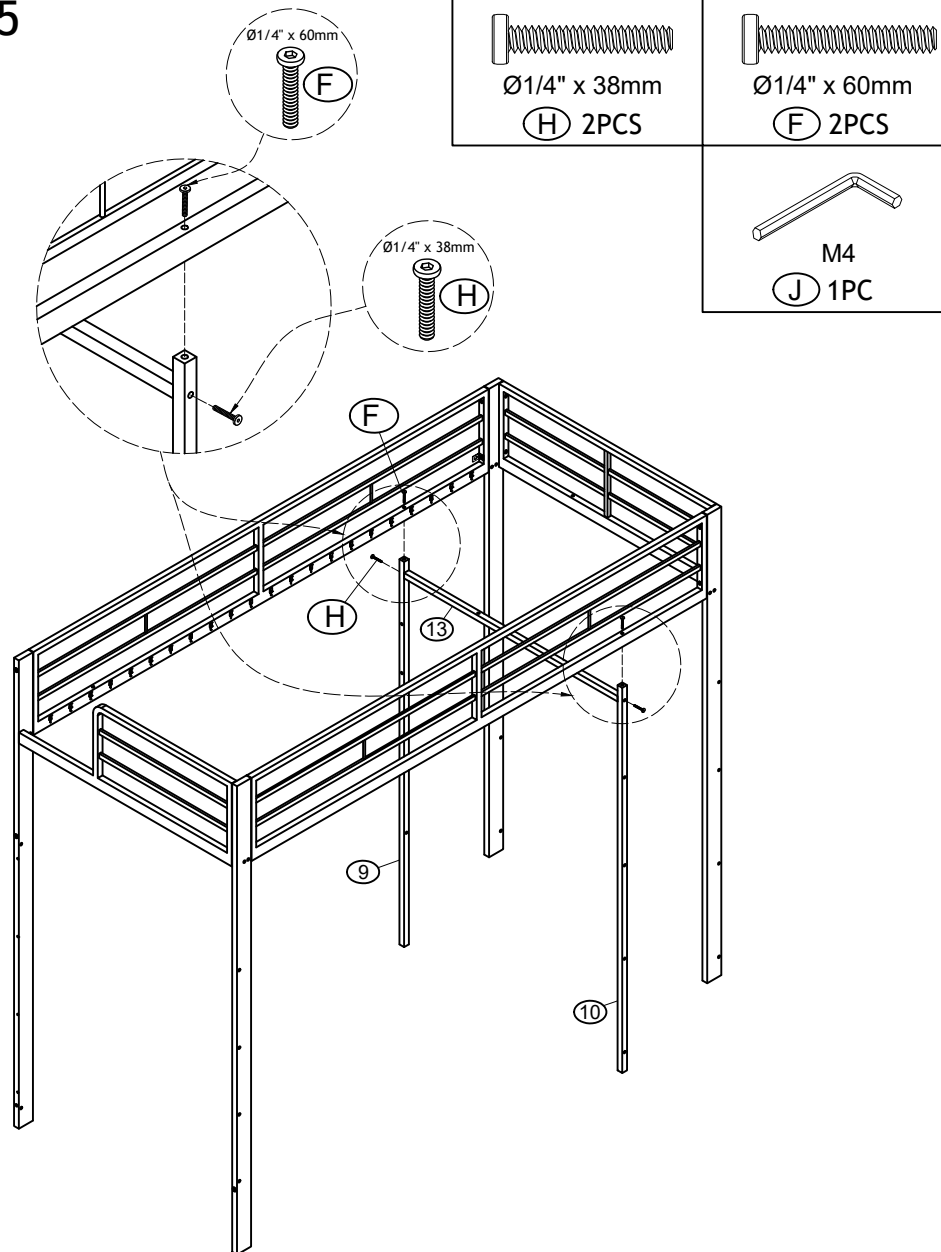

## STEP 6

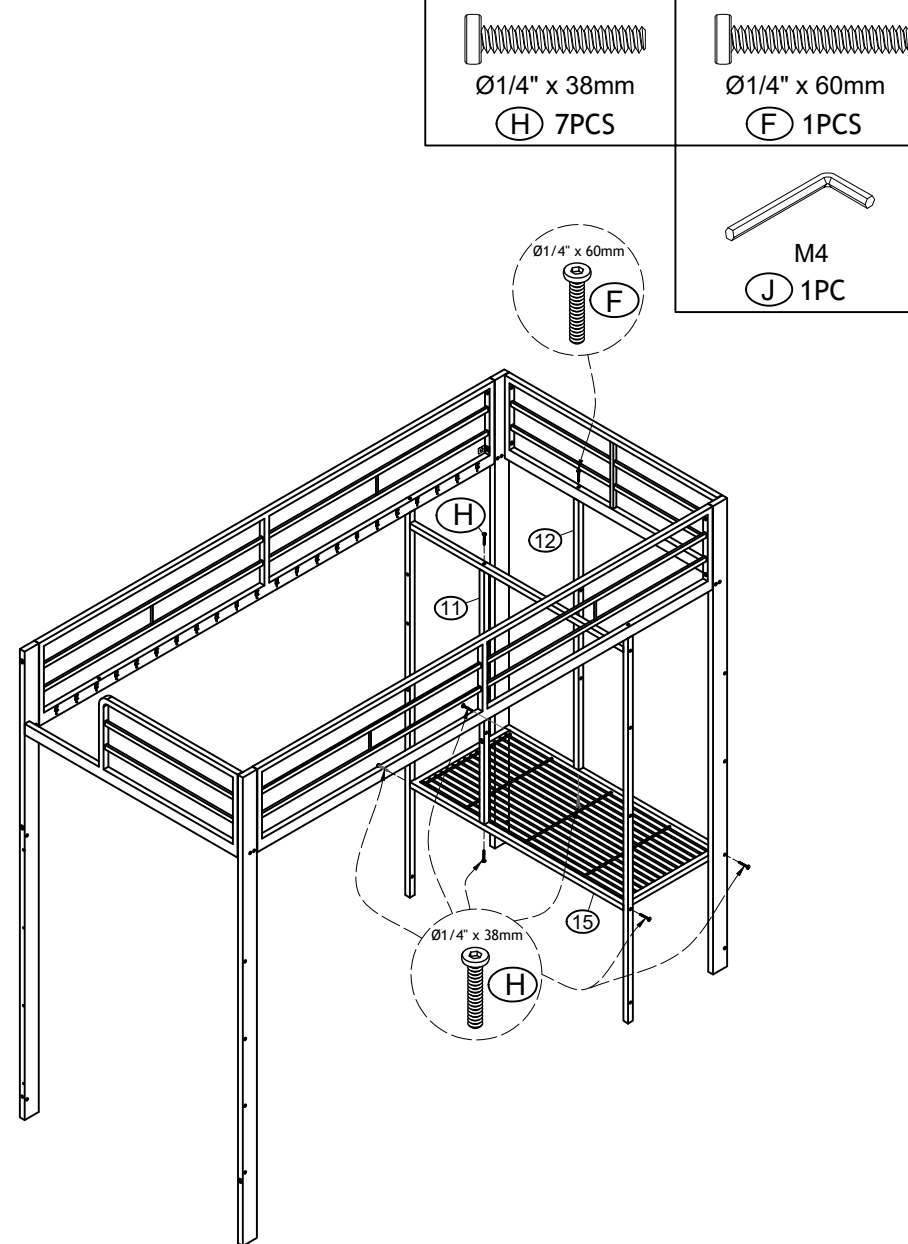

# Montageanleitung für Bettgestell

## STEP 7



Ø1/4" x 38mm

(H) 12PCS

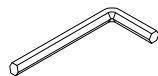

M4

(J) 1PC

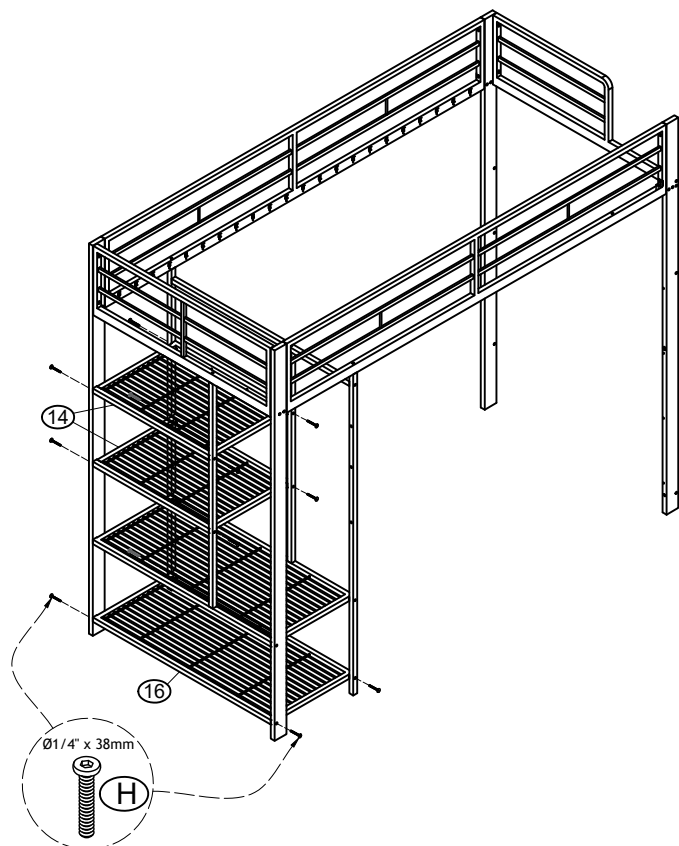

## STEP 8



Ø1/4" x 14mm

(E) 1PC



Ø1/4" x 38mm

(H) 8PCS

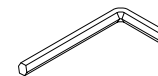

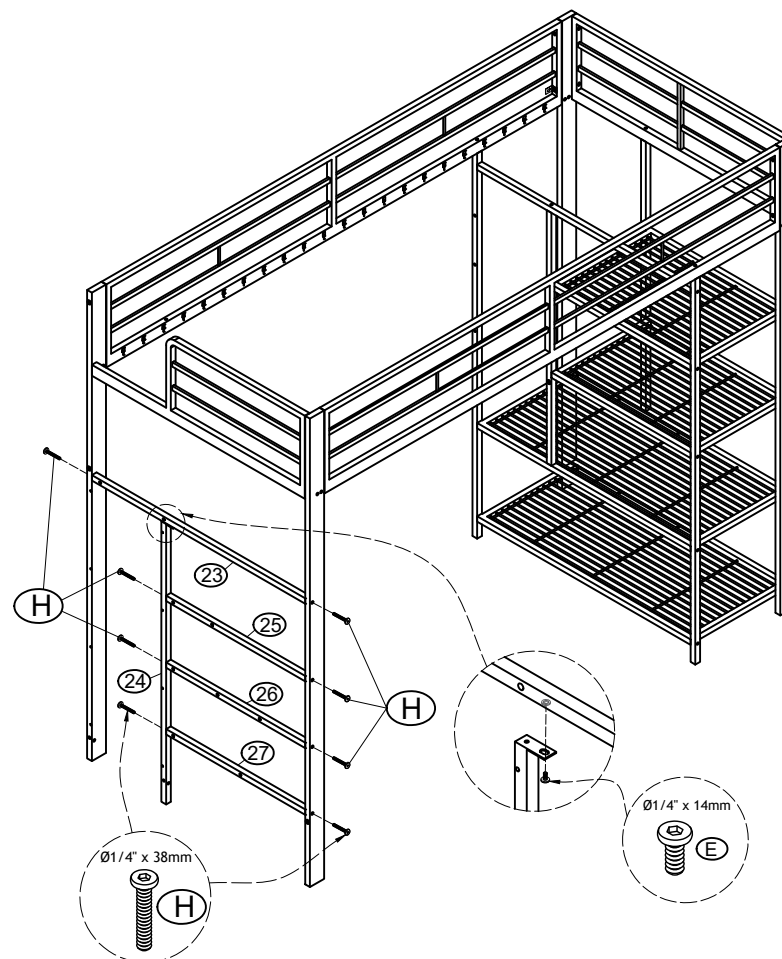

M4

(J) 1PC



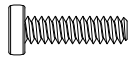

# Montageanleitung für Bettgestell

STEP 9

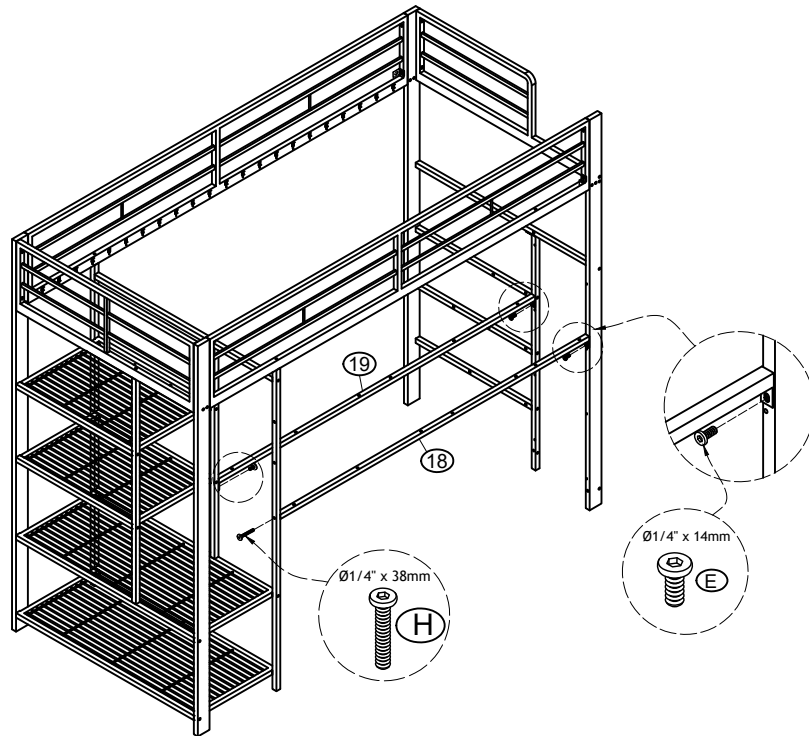
 Ø1/4" x 14mm (E) 3PCS	 Ø1/4" x 38mm (H) 1PC
 M4 (J) 1PC	



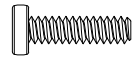
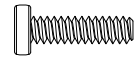

STEP 10

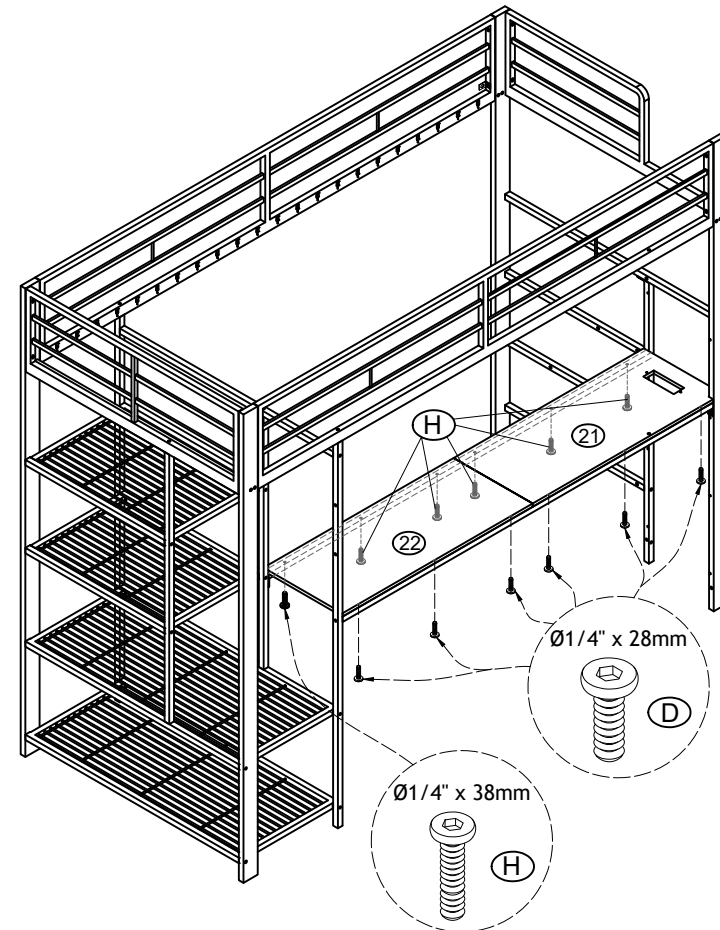
 Ø1/4" x 38mm (H) 6PCS	 Ø1/4" x 28mm (D) 6PCS
 M4 (J) 1PC	



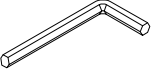

# Montageanleitung für Bettgestell

## STEP 11

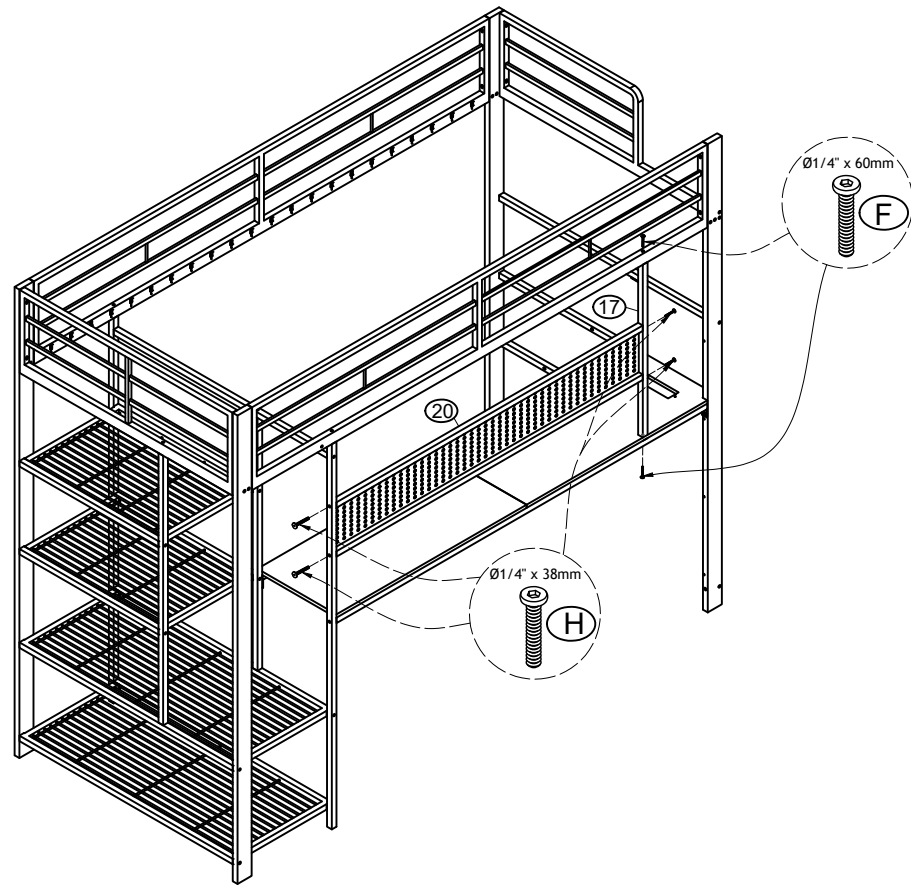
 Ø1/4" x 38mm (H) 4PCS	 Ø1/4" x 60mm (F) 2PCS
 M4 (J) 1PC	

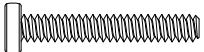
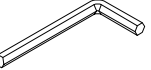

## STEP 12

 Ø1/4" x 38mm (H) 4PCS	 Ø1/4" x 60mm (F) 1PC
 Ø1/4" x 83mm (G) 1PC	 M4 (J) 1PC

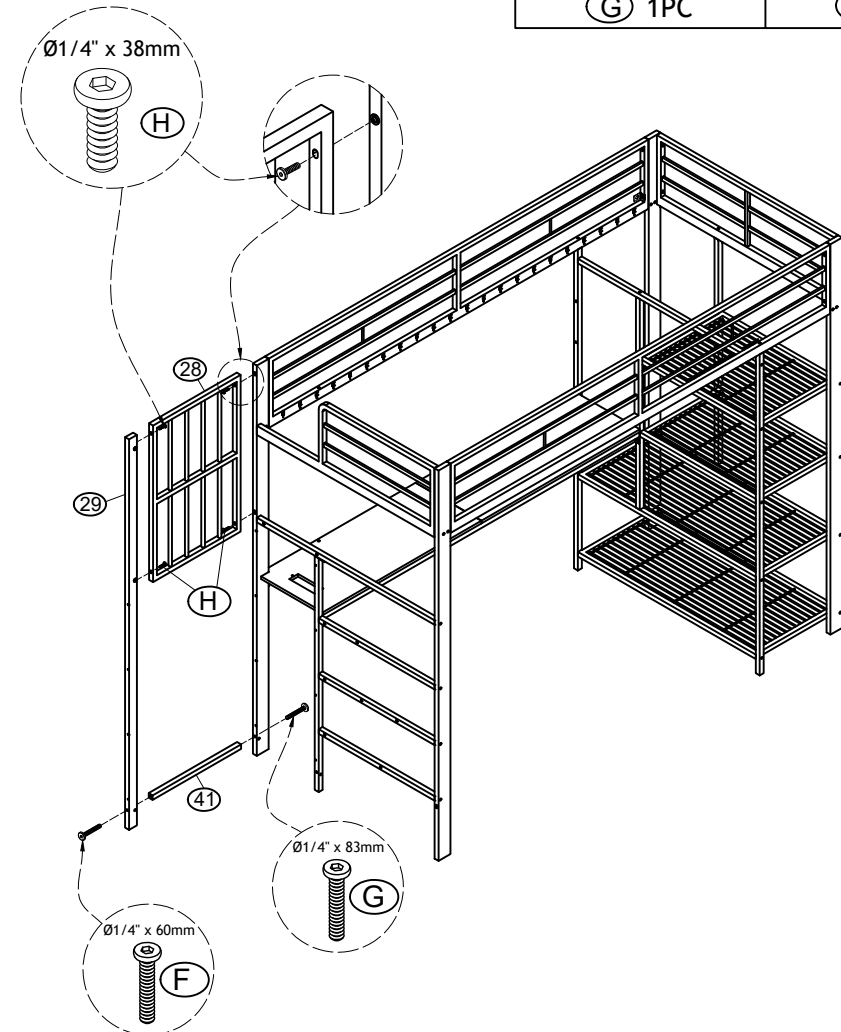

# Montageanleitung für Bettgestell

## STEP 13

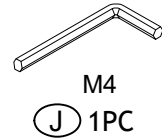
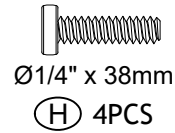
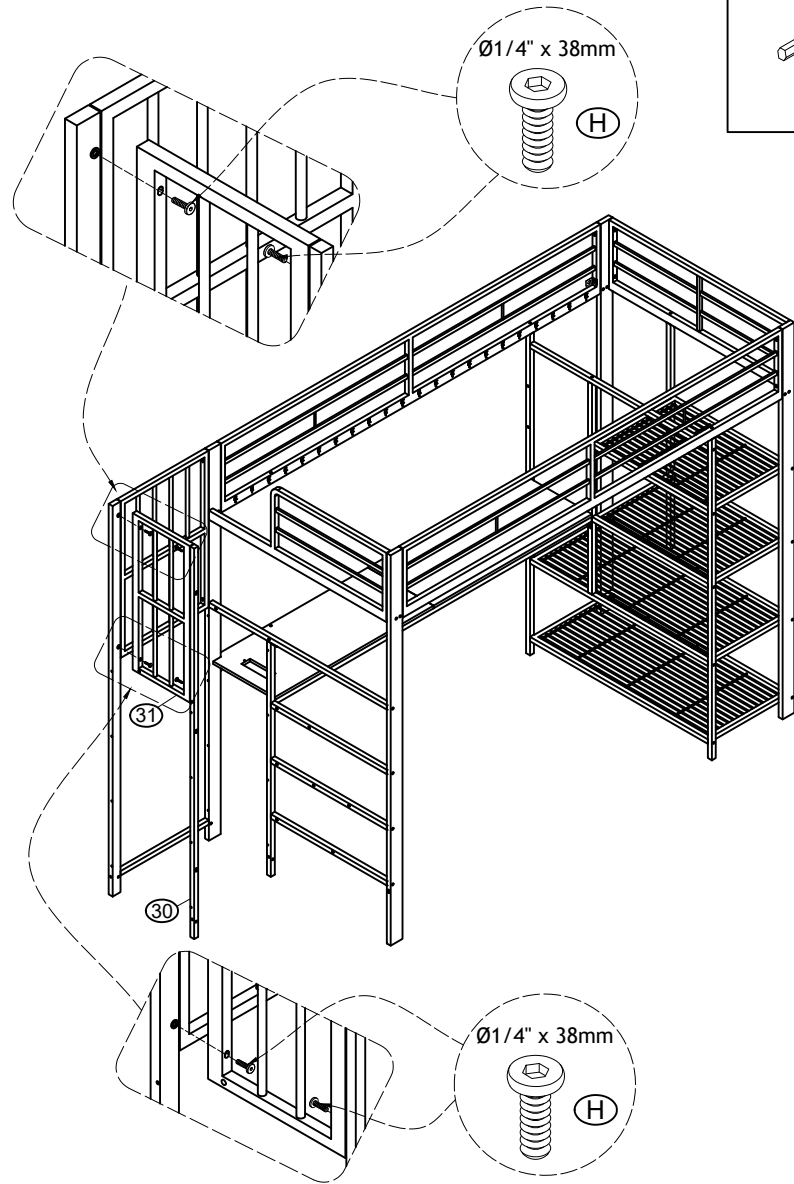

## STEP 14

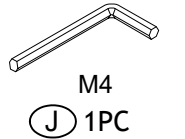
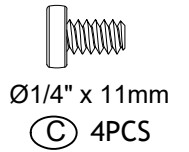
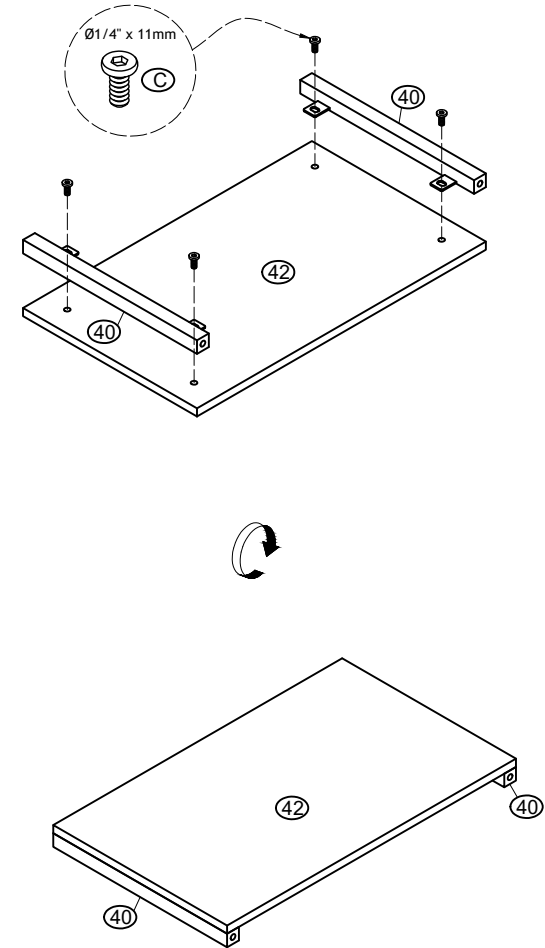

# Montageanleitung für Bettgestell

## STEP 15



Ø1/4" x 38mm

(H) 4PCS



M4

(J) 1PC

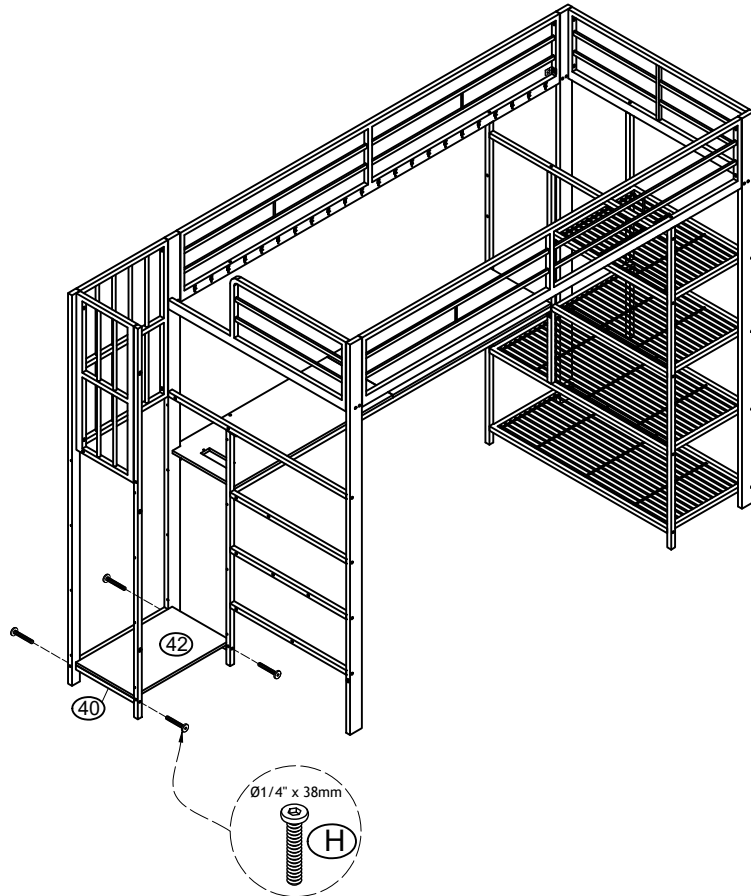

## STEP 16



Ø1/4" x 38mm

(H) 2PCS



M4

(J) 1PC

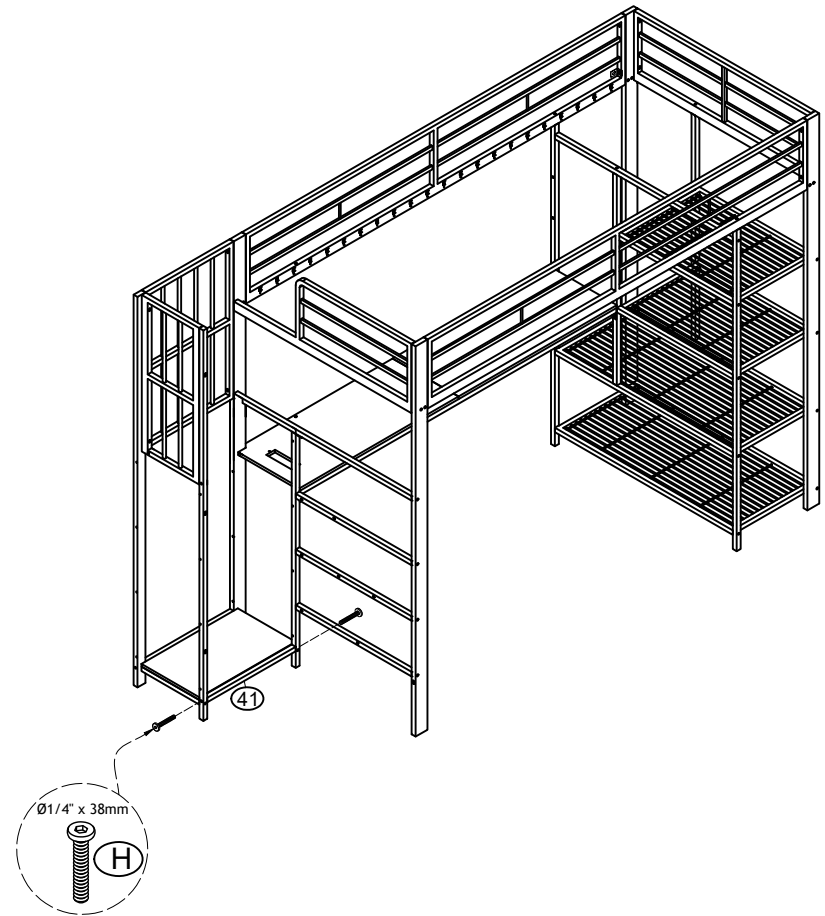

# Montageanleitung für Bettgestell

## STEP 17

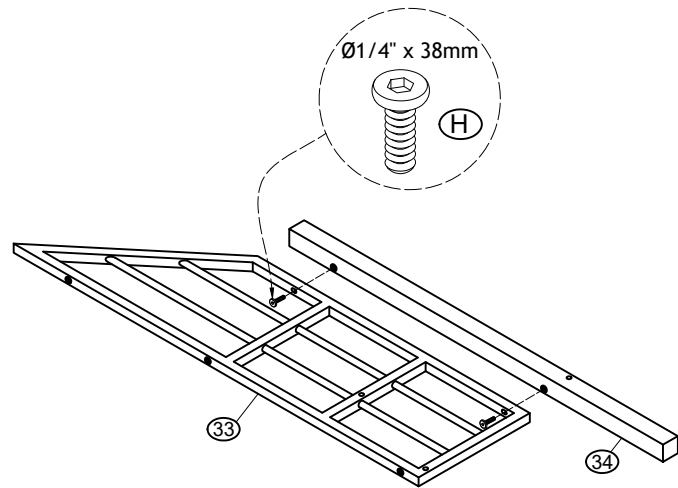
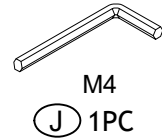
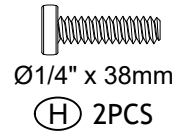

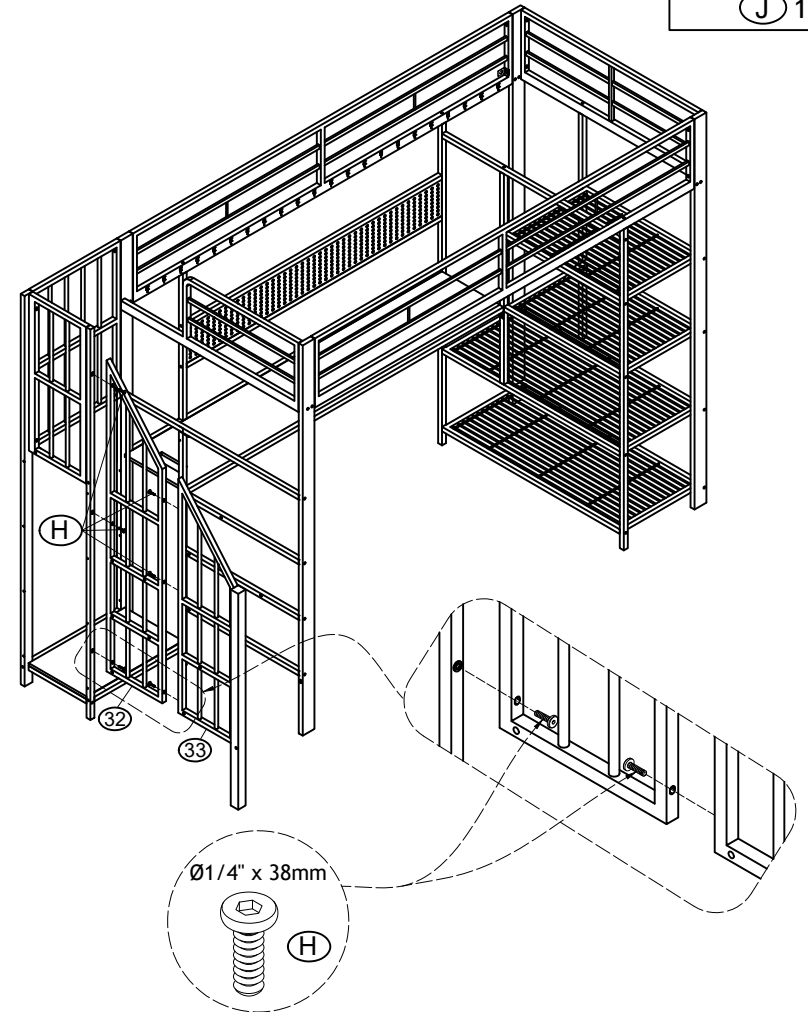
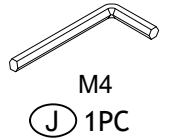
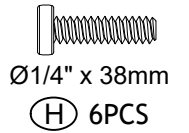

## STEP 18



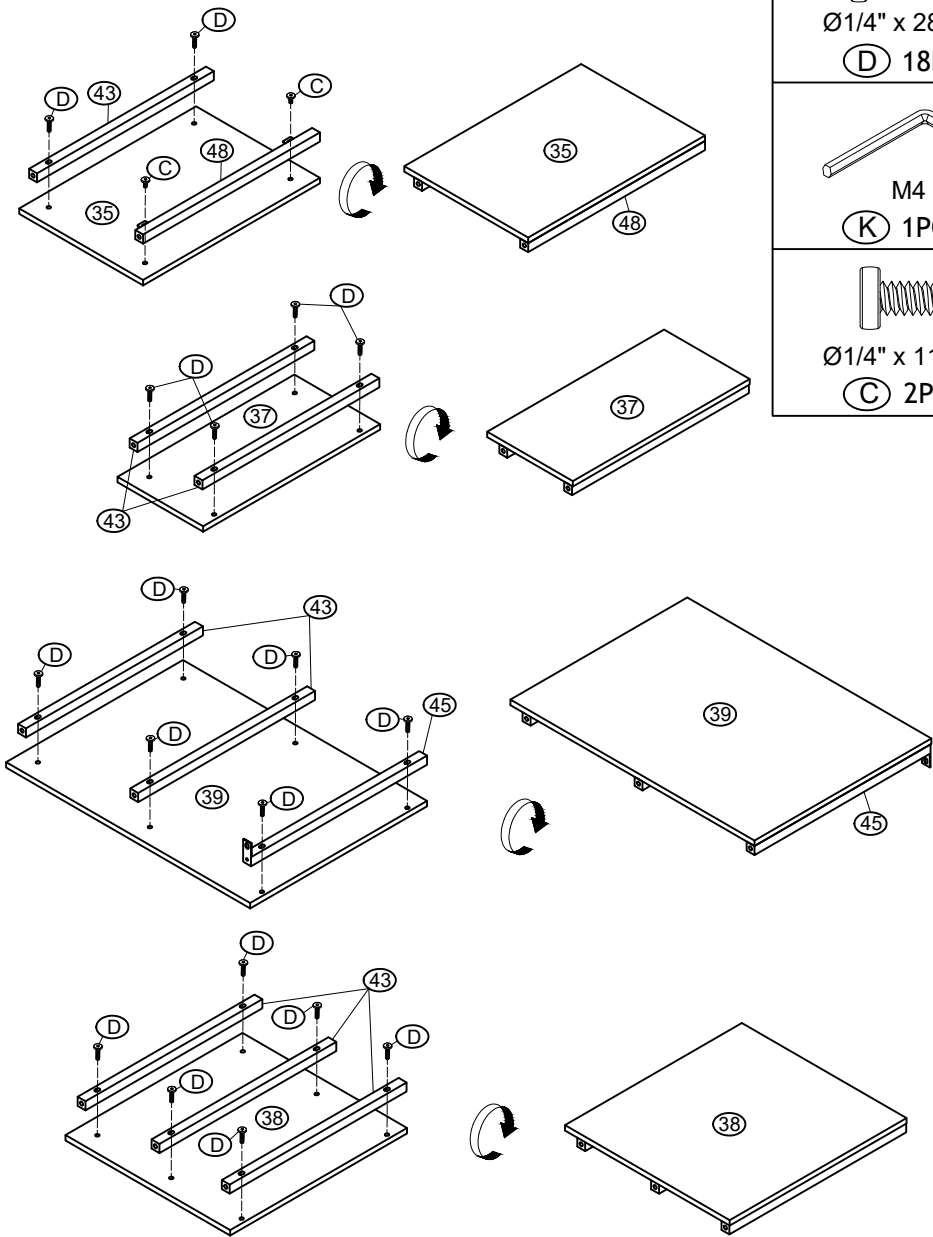

# Montageanleitung für Bettgestell

## STEP 19



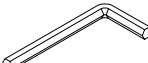

  
 Ø1/4" x 28mm  
 (D) 18PCS

  
 M4  
 (K) 1PC

  
 Ø1/4" x 11mm  
 (C) 2PCS

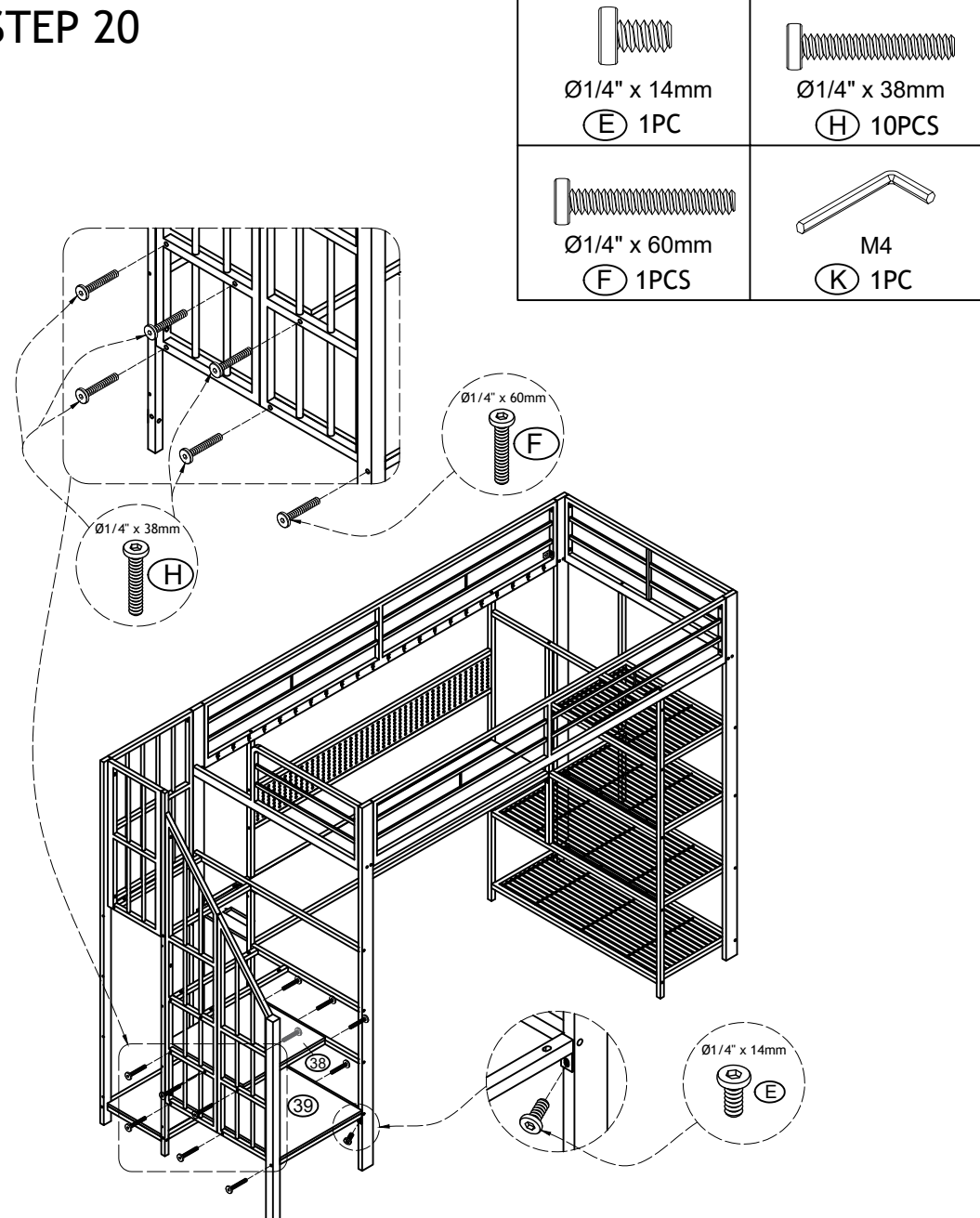
## STEP 20



  
 Ø1/4" x 14mm  
 (E) 1PC

  
 Ø1/4" x 38mm  
 (H) 10PCS

  
 Ø1/4" x 60mm  
 (F) 1PCS

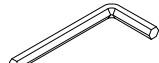
  
 M4  
 (K) 1PC

# Montageanleitung für Bettgestell

## STEP 21

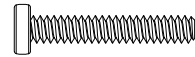
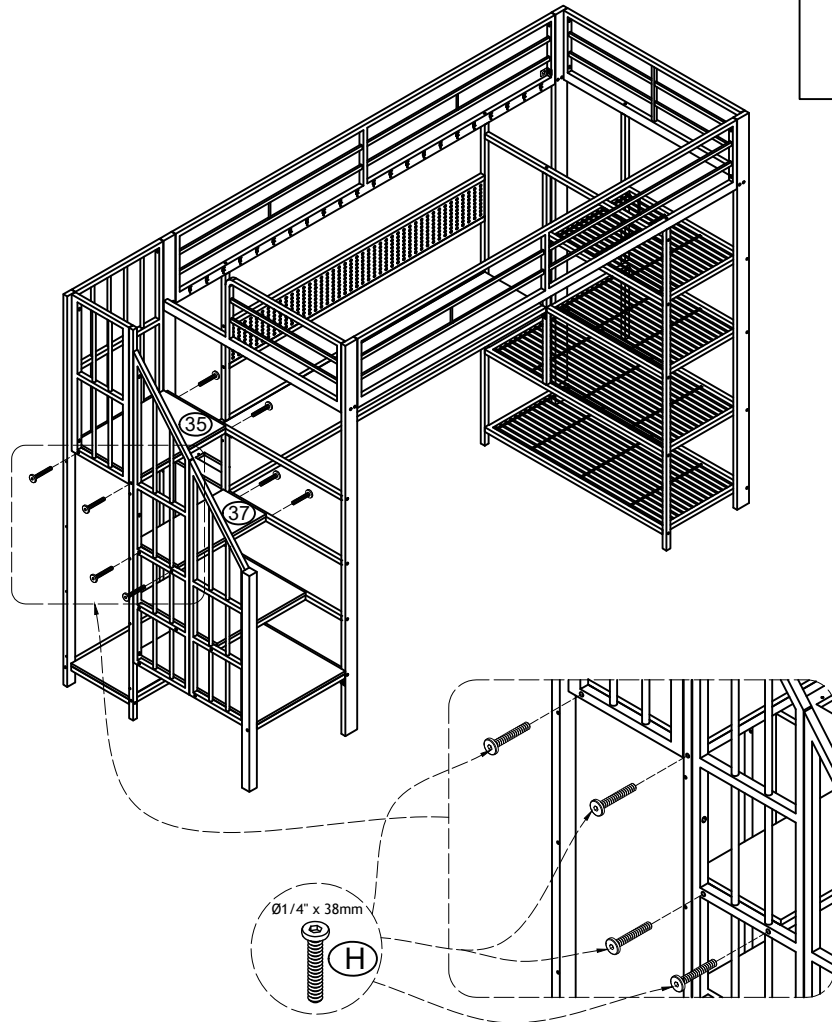

Ø1/4" x 38mm

(H) 8PCS

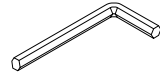

M4

(K) 1PC

## STEP 22

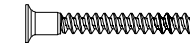
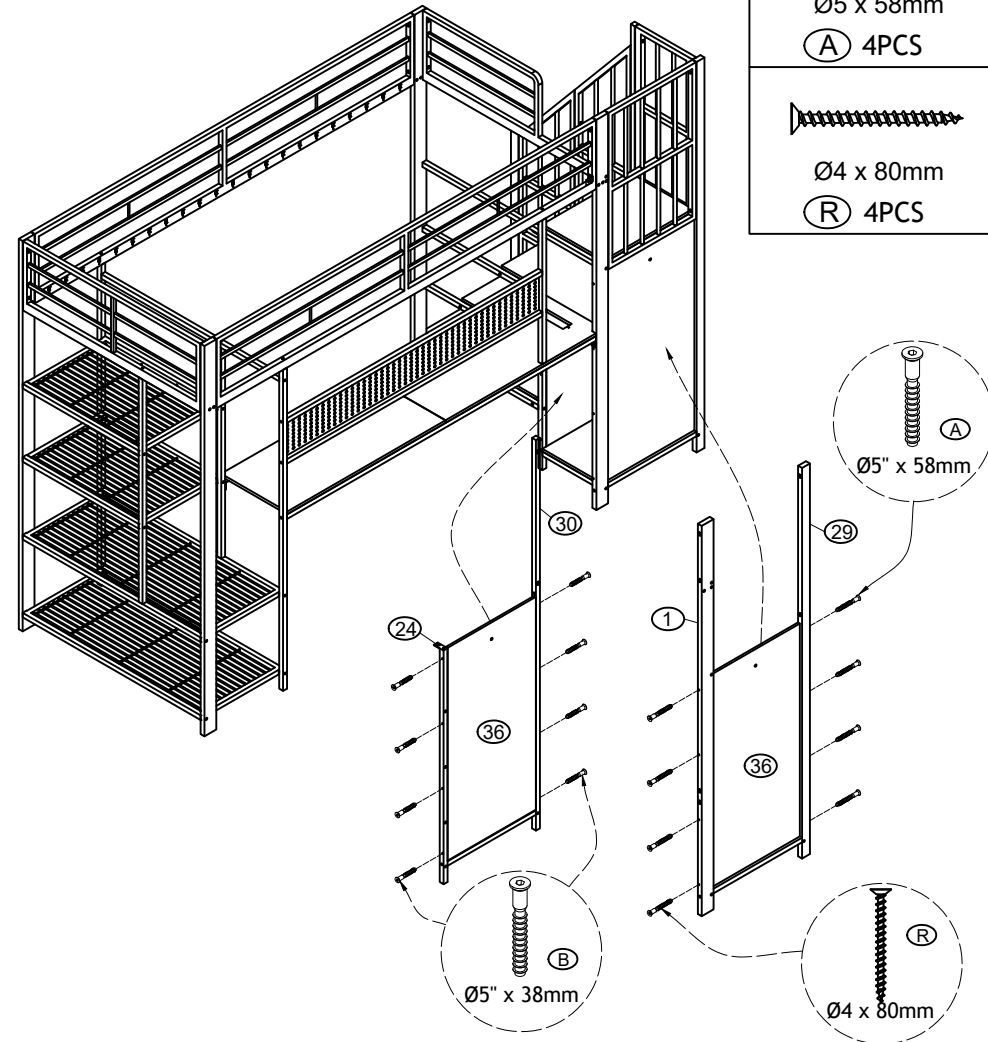

Ø5 x 38mm

(B) 8PCS



M3

(I) 1PC



Ø5 x 58mm

(A) 4PCS

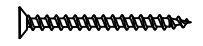

Ø4 x 80mm

(R) 4PCS

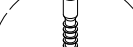

Ø5" x 58mm

(A)



Ø5" x 38mm

(B)



Ø4 x 80mm

(R)

# Montageanleitung für Bettgestell

## STEP 23

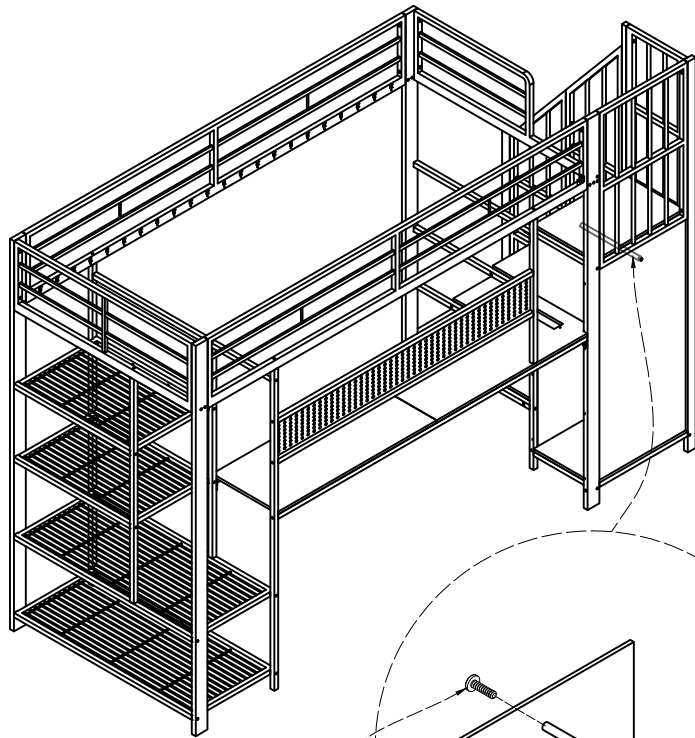

Ø1/4" x 28mm



(D)

44

36

36



Ø1/4" x 28mm

(D) 2PCS

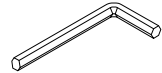

M4

(J) 1PC

## STEP 24

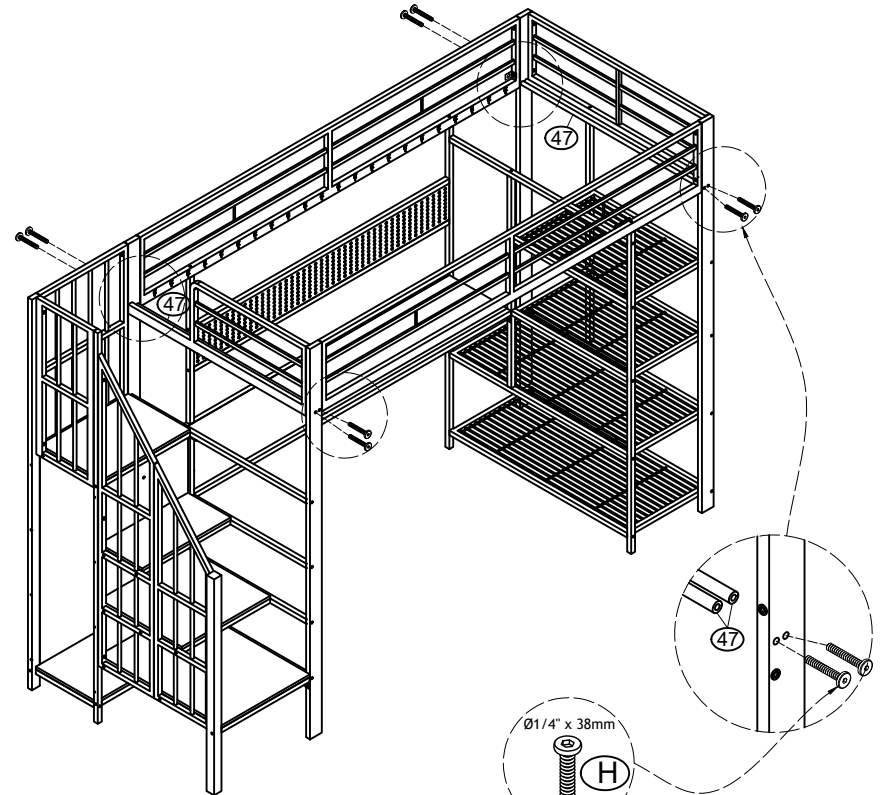

Ø1/4" x 38mm



(H)

47

47

47



Ø1/4" x 38mm

(H) 8PCS

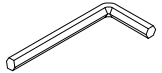

M4

(J) 1PC

# Montageanleitung für Bettgestell

STEP 25

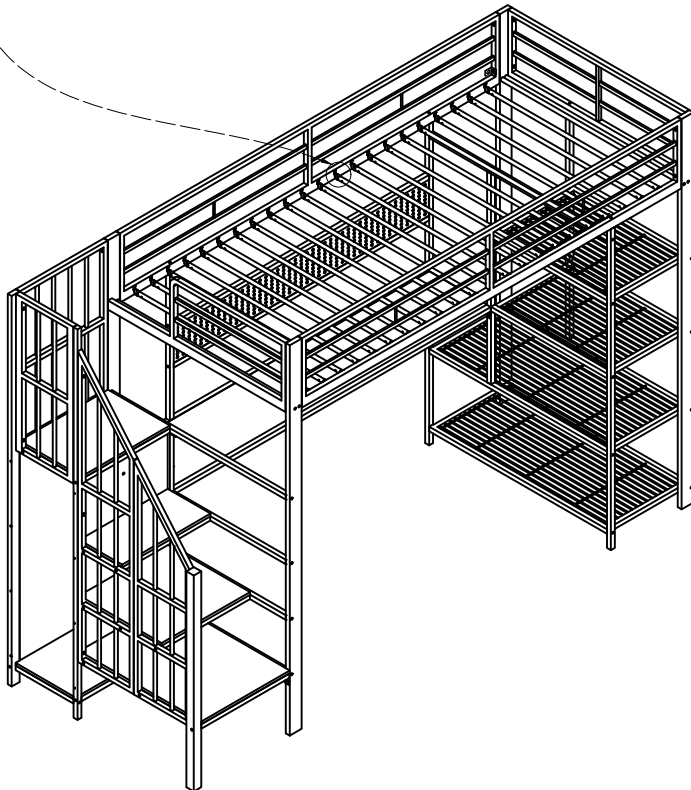
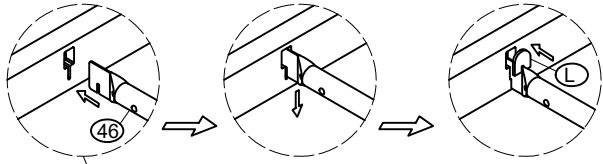

STEP 26

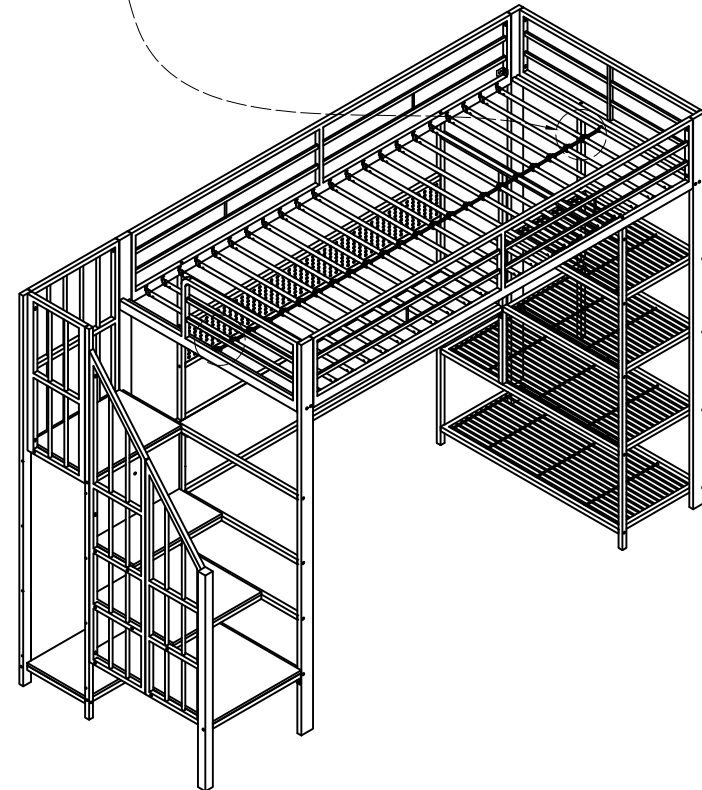
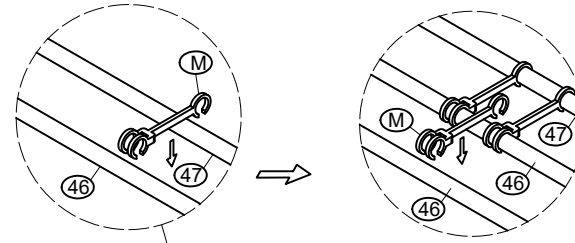
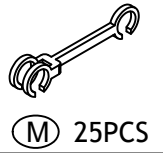

# Montageanleitung für Bettgestell

## STEP 27

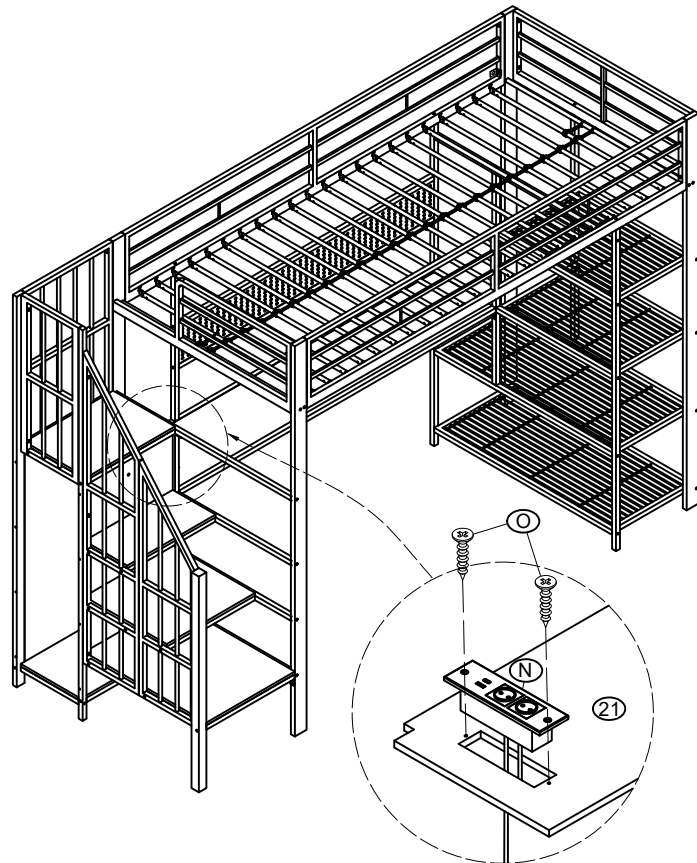

(N) 1PC



φ4 x 12mm

(O) 2PCS

## STEP 28

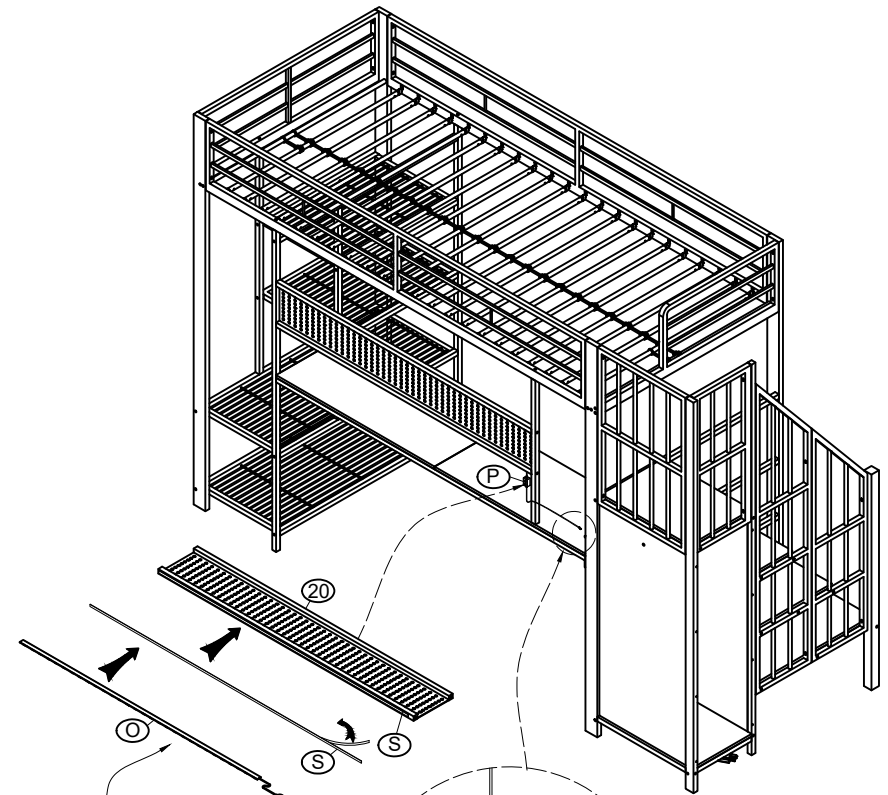

(S) 1PC



(P) 1PC

English: First, stick the EVA strip to the bottom of part 20, and then stick the LED strip onto the EVA strip.

Deutsch: Bringen Sie zunächst das EVA-Band am Boden von Bauteil 20 an, und kleben Sie dann das LED-Lichtband auf das EVA-Band.

Français: Collez d'abord la bande EVA au fond de la pièce 20, puis collez la bande LED sur la bande EVA.

# Montageanleitung für Bettgestell

STEP 29

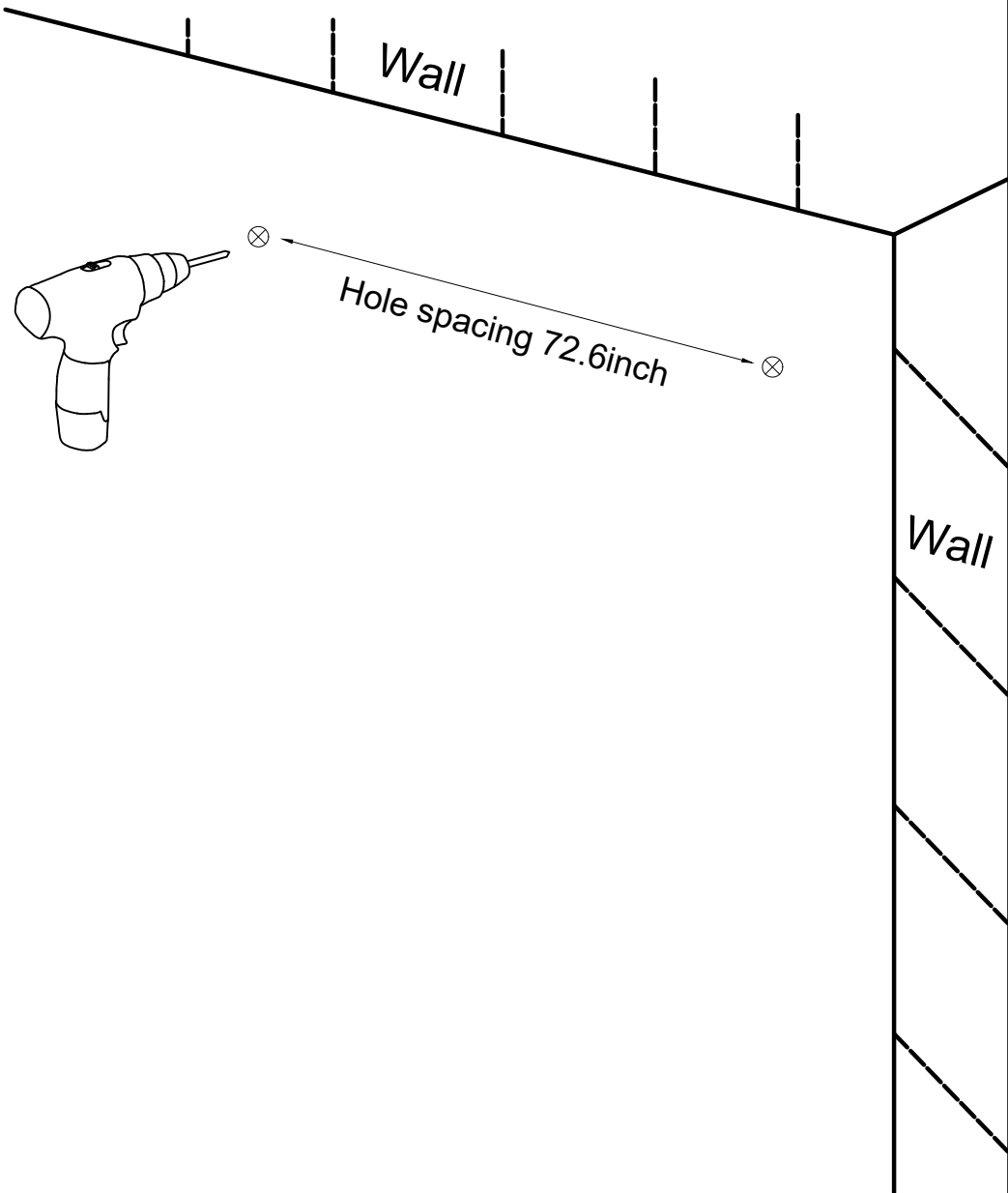

STEP 30

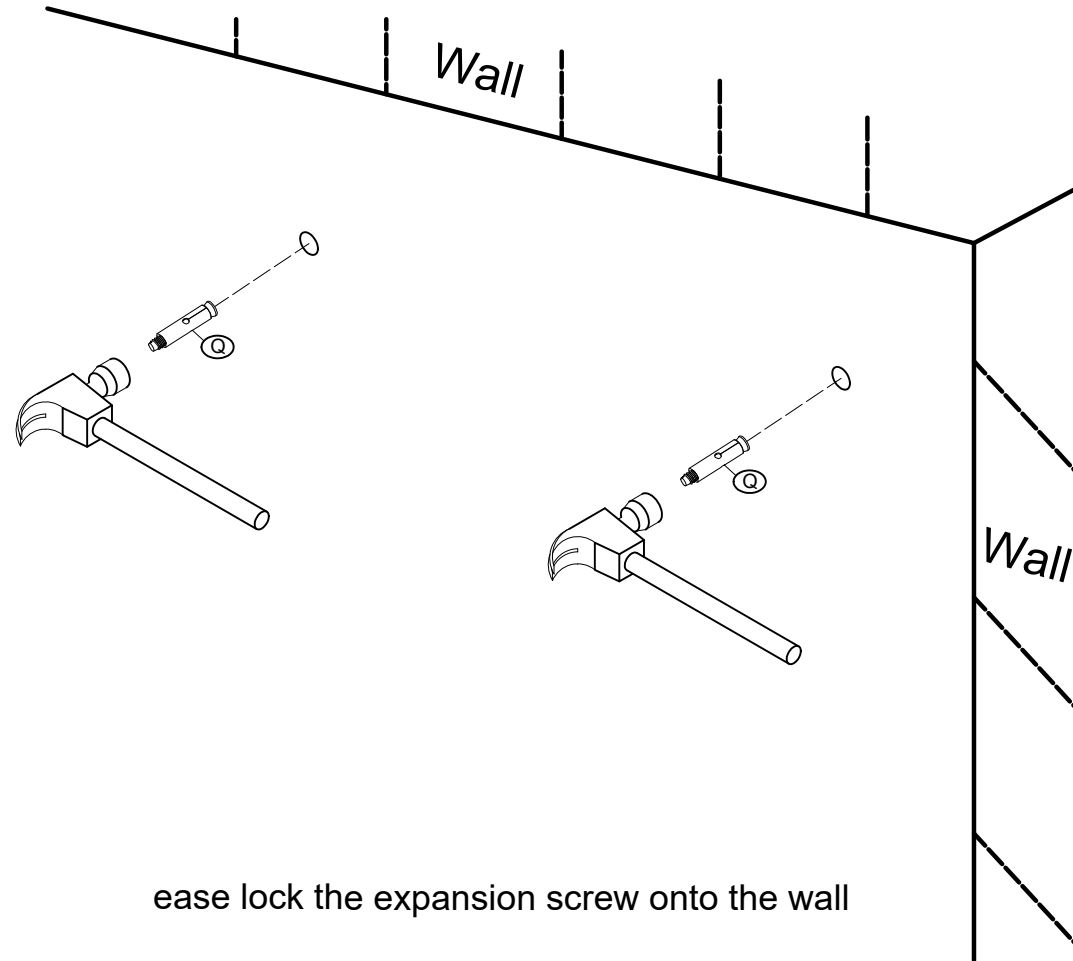
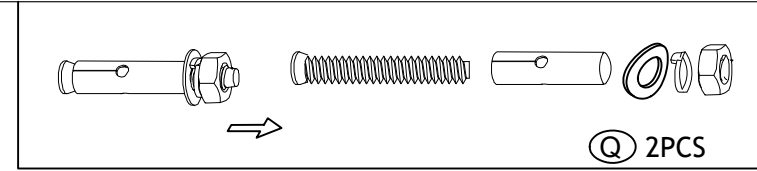

# Montageanleitung für Bettgestell

STEP 31

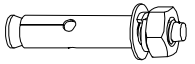
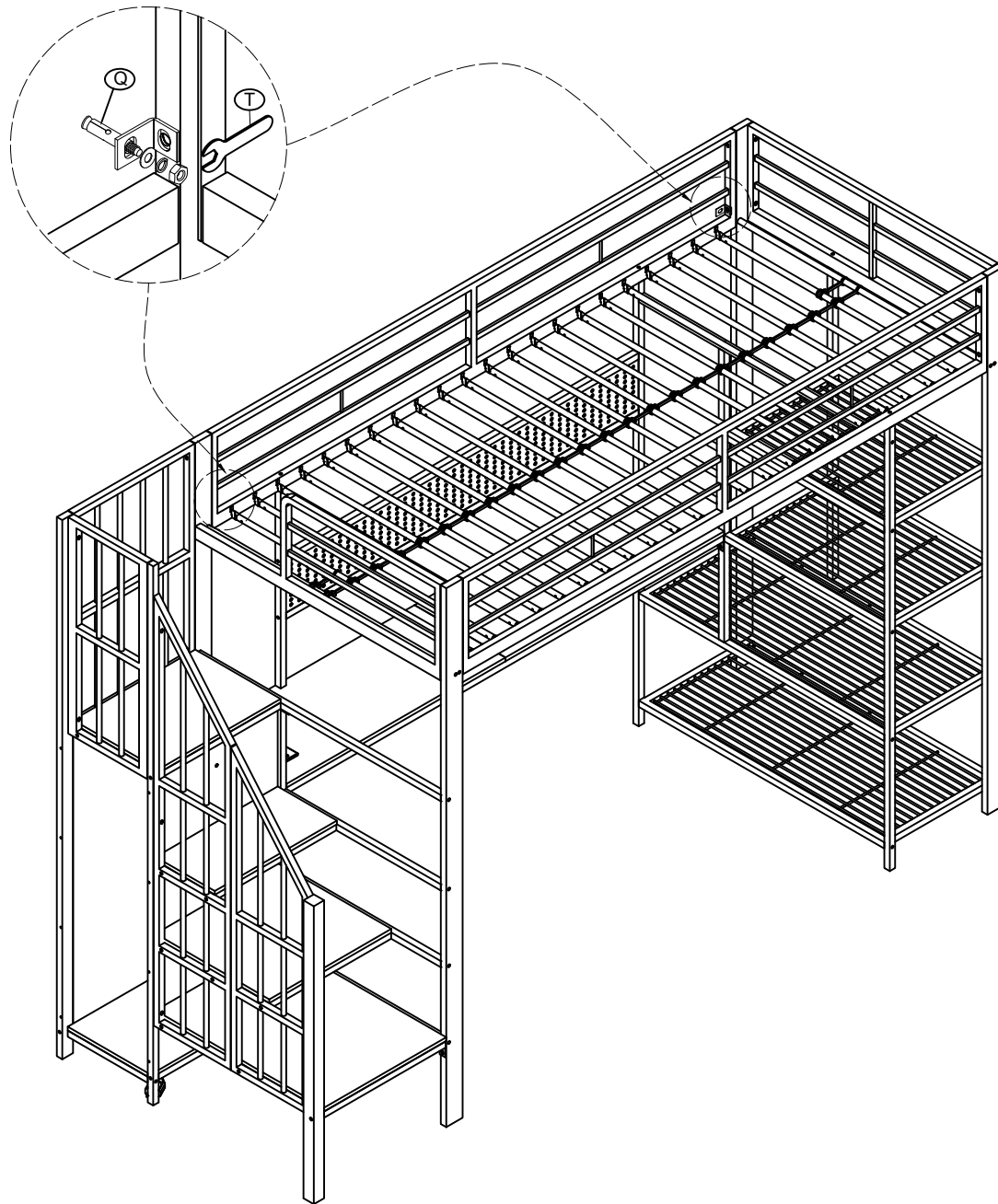

Q 2PCS

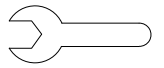

T 1PC

# LotusLantern APP Manual

## 1. Software Overview

### 1.1 Overview

LotusLantern is a mobile APP to control LED strip by both Apple and Android phones.

The traditional control ways like infrared, 433MHz, 2.4GHz and others old wired ways will be replaced by mobile phone control way with convenient, powerful and scalable features.

Through this mobile APP, you can not only control the color, brightness and color temperature of the LED strips but also set up all kinds of fancy flash mode; Also this APP can change the light of the LED strip according to the rhythm of the music. This APP can set and control several LED strips through Bluetooth and the operation is very simple, easy to learn and easy to use.

### 1.2 Features

- Adjust color LED strips with 60,000 colors to change color and brightness and adjust monochrome LED strips to change brightness and color temperature
- Play music or turn on a sound playback device, you can let the light change the color and brightness with the rhythm of music, the music rhythm beautiful
- Inside multiple setting mode for color change and control LED strips without mobile
- Long distance control with omni-directional antenna, and many-to-many group control mode
- Once the connection is successful, connect automatically next time

### 1.3 Performance

LotusLantern APP is easy for use as well as great compatible for all kinds of smart phones; After the actual test of hundreds of mobile phones verification, the compatibility is above 95% of mobile phones in the market. APP is small and convenient, it consumes less system resources, so the requirements of the mobile configuration are low. Control delay is small, the operation feel good, light control is smooth with people's visual sense.

## 2. Operating Environment

This APP program requires phones of system above Android 4.3 and iOS 8.0. Mobile phone configuration is not limited.

## 3. Instructions

Note: Android version and iOS version download and use the same method, here in the Android version as an example.

### 3.1 APP Download

Scan the QR code

iOS and Android systems can download the "LotusLantern" APP by scanning the QR code. Open the browser or other tools with "Scan QR code" function, scan the "LotusLantern" QR code as below:



### 3.2 App Operation

(1) Click on the LotusLantern APP icon, enter the APP page:



(2) After entering the APP interface, if Bluetooth is not enabled, "an application wants to enable the Bluetooth function of this device." Click [Allow]

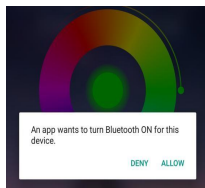

(3) switch to color and brightness interface:

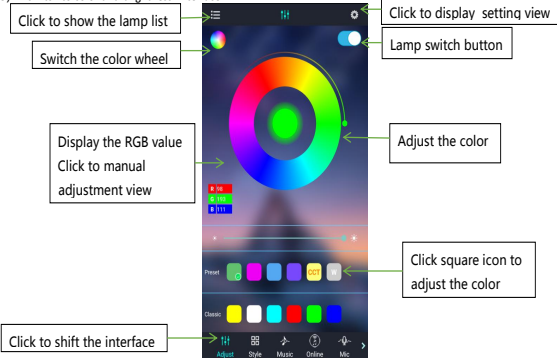

(4) click to show the lamp list, view lamp list:

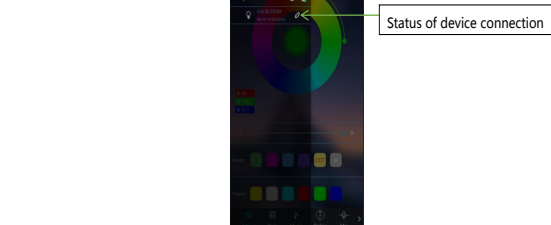

(5) Click to RGB manual adjustment view:



(6) switch to the mode interface:

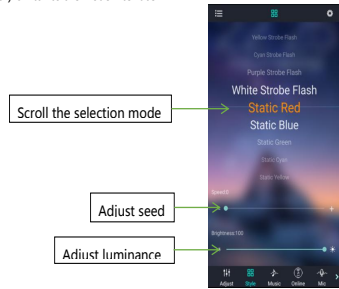

Scroll the selection mode

Adjust seed

Adjust luminance

(7) switch to the music rhythm interface:

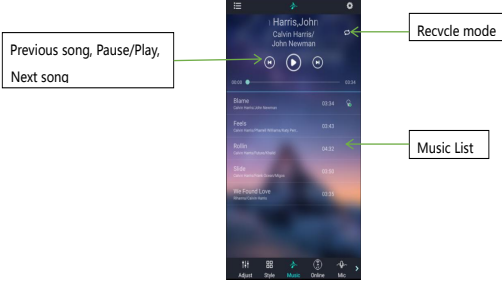

Previous song, Pause/Play, Next song

Recycle mode

Music List

(8) Switch to the online music interface:

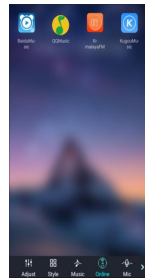

(9) Switch to the microphone rhythm interface:

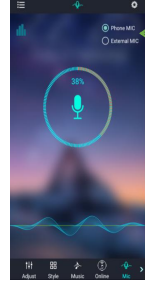

Music rhythm through cell phone microphone

Switch phone microphone and external microphone

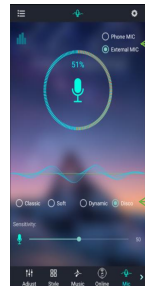

Music rhythm through the microphone on the product

Switch phone microphone and external microphone

4-style rhythm

Change the sensitivity of MIC. to match the sound

(10) Switch to the schedule interface:

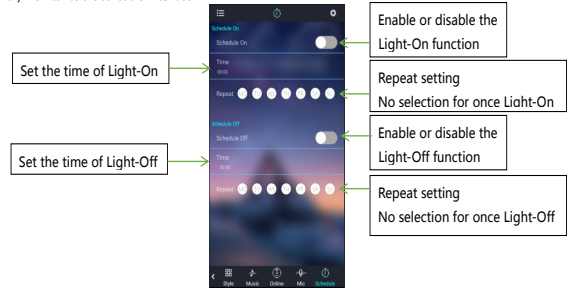

Set the time of Light-On

Set the time of Light-Off

Enable or disable the Light-On function

Repeat setting  
No selection for once Light-On

Enable or disable the Light-Off function

Repeat setting  
No selection for once Light-Off

(11) Switch to the modify pin sequence interface:

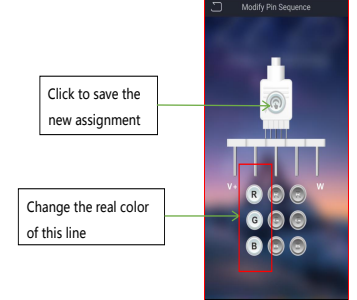

Click to save the new assignment

Change the real color of this line

# Certificate of Conformity

No.: LP24060215C01-01

The following products have been tested by us with the listed standards and found in compliance with the council EMC directive 2014/30/EU. It is demonstrative for the compliance with this EMC Directive.

**Applicant** : Dongguan Yali Electric Appliance Co.,Ltd  
**Address** : 8 / F, Building 9, No. 6, Yuyuan 4th Road, Yuyuan Industrial Zone, Huangjiang Town, Dongguan City, Guangdong Province  
**Product** : Strip power supply  
**Model No.** : YL-SKCE-901, YL-SKCE-902, YL-SKCE-903, YL-SKCE-905, YL-SKCE-906, YL-SKCE-907, YL-SKCE-908, YL-SKCE-909, YL-SKCE-901A, YL-SKCE-902A, YL-SKCE-903A, YL-SKCE-905A, YL-SKCE-906A, YL-SKCE-907A, YL-SKCE-908A, YL-SKCE-909A  
**Test Standards** : EN 55032:2015+A11:2020+A1:2020  
EN 55035:2017+A11:2020  
EN IEC 61000-3-2:2019+A1:2021  
EN 61000-3-3:2013+A1:2019+A2:2021



The CE marking may be used if all relevant and effective EC Directives/Regulations are complied with.

  
Manager: Frank Shen  
Date: October 31, 2024

**Dongguan Lepont Testing Service Co., Ltd.**

Tel.:86-769-83086888 Fax.:86-769-83096886

Room 102, Building 11, No.7, Houjie Science And Technology Avenue, Houjie, Dongguan, Guangdong, China

The statement is based on a single evaluation of one sample of above mentioned products. It does not imply an assessment of the whole production and does not permit the use of the test lab's logo.

# Verification of Compliance

<b>Verification No.:</b>	MK23020083P01-C01R1
<b>Name and address of Applicant:</b>	<b>Shenzhen Hongzhengyu Technology Co., LTD</b> Shenzhen baoan district rock street industrial science and technology industrial park of 2 Haitian lanyu 3 5 floor of A
<b>Name and address of Manufacturer:</b>	<b>Shenzhen Hongzhengyu Technology Co., LTD</b> Shenzhen baoan district rock street industrial science and technology industrial park of 2 Haitian lanyu 3 5 floor of A
<b>Product name:</b>	<b>Lamp strip</b> HZY-2835-120D-12V, HZY-2835-30D-5V, HZY-2835-60D-5V, HZY-2835-120D-5V, HZY-2835-60D-12V, HZY-2835-60D-24V, HZY-2835-120D-24V, HZY-2835RGB-60D-5V, HZY-2835RGB-60D-12V, HZY-5050-30D-5V, HZY-5050-60D-5V, HZY-5050-30D-12V, HZY-5050-60D-12V, HZY-5050-60D-24V, HZY-5050RGB-30D-5V, HZY-5050RGB-60D-5V, HZY-5050RGB-30D-12V, HZY-5050RGB-60D-12V, HZY-5050RGB-60D-24V
<b>Product model(s):</b>	
<b>Product trademark:</b>	N/A

This verification confirms that the product meets the requirements of the following standard. The conformity was demonstrated based on following standard(s) listed by European Commission as harmonized with Directive RoHS 2.0 Directive (EU) 2015/863 and (EU)2017/2102 amending Annex II to Directive 2011/65/EU

IEC 62321-1:2013	IEC 62321-3-1:2013
IEC 62321-4:2013/AMD1:2017	IEC 62321-5:2013
IEC 62321-6:2015	IEC 62321-7-1:2015
IEC 62321-7-2:2017	IEC 62321-8:2017
IEC 62321-2:2021	

The verification has been carried out in accordance with individual rules and conditions agreed with the applicant. Evaluation has been carried out in accordance with:

<b>Test report(s) No.:</b>	MK23020083P01-C01R1
<b>Test conducted by:</b>	TMC Testing Services (Shenzhen) Co., Ltd.
<b>Verification issue date:</b>	December 4, 2025

#### Notes:

This verification refers to the above mentioned product and its conformity in regards of above mentioned standard(s) was proven on test sample.

This verification does not imply meeting all essential requirements, assessment of the series-production or any other restricted Notified Bodies conformity assessment procedure appropriate for the product.

This verification holder shall use this verification in connection to verification of conformity and technical data relevant for the product the verification was issued.

#### TMC Testing Services (Shenzhen) Co., Ltd.

t:86-755-86642861 cert@tmc-lab.com www.tmc-lab.com

1st Floor, Block A1, Zone A, Xinshidai Gongrong Industrial Park, No. 2, Shihuan Road, Shiyuan Street, Baoan District, Shenzhen, China



# RoHS

# Verification of Compliance

Verification No.:	MK23020083-P01E01
Name and address of Applicant:	<b>Shenzhen Hongzhengyu Technology Co., LTD</b> Shenzhen baoan district rock street industrial science and technology industrial park of 2 Haitian lanyu 3 5 floor of A
Name and address of Manufacturer:	<b>Shenzhen Hongzhengyu Technology Co., LTD</b> Shenzhen baoan district rock street industrial science and technology industrial park of 2 Haitian lanyu 3 5 floor of A
Product name:	<b>Lamp strip</b>
Rated:	5V $\overline{\text{---}}$ 1A HZY-2835-120D-12V, HZY-2835-30D-5V, HZY-2835-60D-5V, HZY-2835-120D-5V, HZY-2835-60D-12V, HZY-2835-60D-24V, HZY-2835-120D-24V, HZY-2835RGB-60D-5V, HZY-2835RGB-60D-12V, HZY-5050-30D-5V, HZY-5050-60D-5V, HZY-5050-30D-12V, HZY-5050-60D-12V, HZY-5050-60D-24V, HZY-5050RGB-30D-5V, HZY-5050RGB-60D-5V, HZY-5050RGB-30D-12V, HZY-5050RGB-60D-12V, HZY-5050RGB-60D-24V
Product model(s):	
Product trademark:	N/A

This verification confirms that the product meets the requirements of the following standard.

The conformity was demonstrated based on following standard(s) listed by European Commission as harmonized with EMC Directive 2014/30/EU.

EN IEC 55015:2019+A11:2020

IEC 61547:2020

*The verification has been carried out in accordance with individual rules and conditions agreed with the applicant. Evaluation has been carried out in accordance with:*

Test report(s) No.: MK23020083-P01E01

Test conducted by: TMC Testing Services (Shenzhen) Co., Ltd.

Verification issue date: February 25, 2023

Notes:

*This verification refers to the above mentioned product and its conformity in regards of above mentioned standard(s) was proven on test sample.*

*This verification does not imply meeting all essential requirements, assessment of the series-production or any other restricted Notified Bodies conformity assessment procedure appropriate for the product.*

*This verification holder shall use this verification in connection to verification of conformity and technical data relevant for the product the verification was issued.*

TMC Testing Services (Shenzhen) Co., Ltd.

t:86-755-86642861 cert@tmc-lab.com www.tmc-lab.com

1st Floor, Block A1, Zone A, Xinshidai Gongrong Industrial Park, No. 2, Shihuan Road, Shiyan Street, Baoan District, Shenzhen, China



# CERTIFICATE OF CONFORMITY

The following products have been tested by us and found in conformity with the (RoHS) Directive 2011/65/EU Annex II amending Directive (EU)2015/863. It is possible to use CE marking to demonstrate the conformity with this Directive.

Report No. : XNO251021001CX2-1  
Applicant : YA LI ELECTRIC CO LTD  
Address : Room 801, Building 9, No. 6, Yuyuan 4th Road, Huangjiang Town, DONGGUAN Guangdong 523000  
Sample Name: : Furniture power distribution unit  
Model No.: : YL-SKCE-909A  
Sub-Model No.: : YL-SKCE-901, YL-SKCE-901A, YL-SKCE-902, YL-SKCE-902A, YL-SKCE-903, YL-SKCE-903A, YL-SKCE-905, YL-SKCE-905A, YL-SKCE-905C, YL-SKCE-906, YL-SKCE-906A, YL-SKCE-907, YL-SKCE-907A, YL-SKCE-908, YL-SKCE-908A, YL-SKCE-909  
Manufacturer : YA LI ELECTRIC CO LTD  
Manufacturer Address : Room 801, Building 9, No. 6, Yuyuan 4th Road, Huangjiang Town, DONGGUAN Guangdong 523000  
Test method : IEC 62321-3-1:2013 & IEC 62321-5:2013 & IEC 62321-4:2013+A1:2017 & IEC 62321-7-1:2015 & IEC 62321-7-2:2017 & IEC 62321-6:2015 & IEC 62321-8:2017



Signature : 

Technical supervisor

Signed for and on behalf of

Guangzhou Supreme Technology & Testing Service Co., LTD

21-Oct-2025



This certification is part of the full test report(s) and should be read in conjunction with it. The certificate is based on a single evaluation of one sample of above-mentioned products. It does not imply an assessment of the whole production and does not permit the use of the test lab logo.

Guangzhou Supreme Technology & Testing Service Co., LTD

103, NanSha IT Park, South Tower, No.2 HuanShi Dadao Nan, NanSha District, GuangZhou City, GuangDong Province,China

Tel: 020-39004143

Fax: 020-39990517

Email: service@xnotesting.com

Website: <http://www.xnotesting.com>

Shenzhen ZKT Technology Co., Ltd.  
 1/F, No. 101, Building B, No. 6, Tangwei Community Industrial Avenue,  
 Fuhai Street, Bao'an District, Shenzhen, China



# Certificate of Compliance

Certificate Number: ZKT-25070215182C

**Certificate's Holder** : Dongguan Yihong Hardware Electronics Co., Ltd  
 Room 1106, No.2, Shangheng Road, Chang' an Town,  
 Dongguan

**Manufacturer** : Dongguan Yihong Hardware Electronics Co., Ltd  
 Room 1106, No.2, Shangheng Road, Chang' an Town,  
 Dongguan

**Trade Mark** : N/A

**Product** : LED controller

**Model(s)** : YH-6183  
 YH-252, YH-284, YH-290, YH-287, YH-358, YH-360, YH-6180,  
 YH-6184

Requirement	Standard	Report No.
Art.3.1(a) Safety	EN IEC 62368-1:2024+A11:2024	ZKT-25070215183S
Art.3.1(a) Health	EN IEC 62311:2020 EN 50665:2017	ZKT-25070215182E-1
Art.3.1(b) EMC	ETSI EN 301 489-1 V2.2.3 (2019-11) ETSI EN 301 489-17 V3.3.0 (2024-07)	ZKT-25070215182E-2
Art.3.2 Radio	ETSI EN 300 328 V2.2.2 (2019-07)	ZKT-25070215182E-3

This Attestation of Compliance is issued on a voluntary basis for electrical equipment below the voltage limits of Radio Equipment Directive (RED) 2014/53/EU. The essential requirements are fulfilled accordingly based on the technical specifications applicable at the time of issuance.



This Certificate of Conformity is based on single evaluation of the submitted sample(s) of the above mentioned product. It does not imply an assessment of the whole product and relevant Directives to be observed.



Product Service

# Attestation of Conformity

No. N8A 129388 0002 Rev. 00

**Holder of Attestation: Dongguan Yali Electric  
Appliance Co., Ltd.**

8/F, Building 9, No. 6, Yuyuan 4th Road  
Yuyuan Industrial Zone, Huangjiang Town  
523750 Dongguan City, Guangdong Province  
PEOPLE'S REPUBLIC OF CHINA

**Product: Socket-outlets**

This Attestation of Conformity is issued on a voluntary basis according to the Low Voltage Directive 2014/35/EU relating to electrical equipment designed for use within certain voltage limits. It confirms that the listed equipment complies with the principal protection requirements of the directive and is based on the technical specifications applicable at the time of issuance. It refers only to the particular sample submitted for conformity assessment. For details see: [www.tuvsud.com/ps-cert](http://www.tuvsud.com/ps-cert)

Test report no.: 6810024020801

Date, 2024-12-04

  
( Michael Xu )

Page 1 of 2

This Attestation does not replace the regulatory EU Declaration of Conformity (DoC) and does not allow for CE marking. After preparation of the necessary documentation and establishing compliance to requirements of all applicable directives, the manufacturer may sign a DoC and apply the CE marking. The DoC is issued under the sole responsibility of the manufacturer.



Product Service

# Attestation of Conformity

No. N8A 129388 0002 Rev. 00

**Model(s):**

YL-SKCE-901, YL-SKCE-901A, YL-SKCE-901A-PD20W,  
YL-SKCE-902, YL-SKCE-902A, YL-SKCE-902A-PD20W,  
YL-SKCE-903, YL-SKCE-903A, YL-SKCE-903A-PD20W,  
YL-SKCE-905, YL-SKCE-905A, YL-SKCE-905A-PD20W,  
YL-SKCE-906, YL-SKCE-906A, YL-SKCE-906A-PD20W,  
YL-SKCE-907, YL-SKCE-907A, YL-SKCE-907A-PD20W,  
YL-SKCE-908, YL-SKCE-908A, YL-SKCE-908A-PD20W,  
YL-SKCE-909, YL-SKCE-909A, YL-SKCE-909A-PD20W

**Parameters:**

Rated voltage: 250Vac

Rated frequency: 50/60Hz

Rated current: 16A

Protection class: I

Degree of protection: IP20

Type of cable: H05VV-F 3G1.5mm<sup>2</sup>**Tested  
according to:**

DIN VDE 0620-1:2021

DIN VDE 0620-2-1:2021/A1:2023

Page 2 of 2

This Attestation does not replace the regulatory EU Declaration of Conformity (DoC) and does not allow for CE marking. After preparation of the necessary documentation and establishing compliance to requirements of all applicable directives, the manufacturer may sign a DoC and apply the CE marking. The DoC is issued under the sole responsibility of the manufacturer.