

# Installation sanleitung Installation Instruction Instruction d'installation

SKU: N634P433762/N634P433763

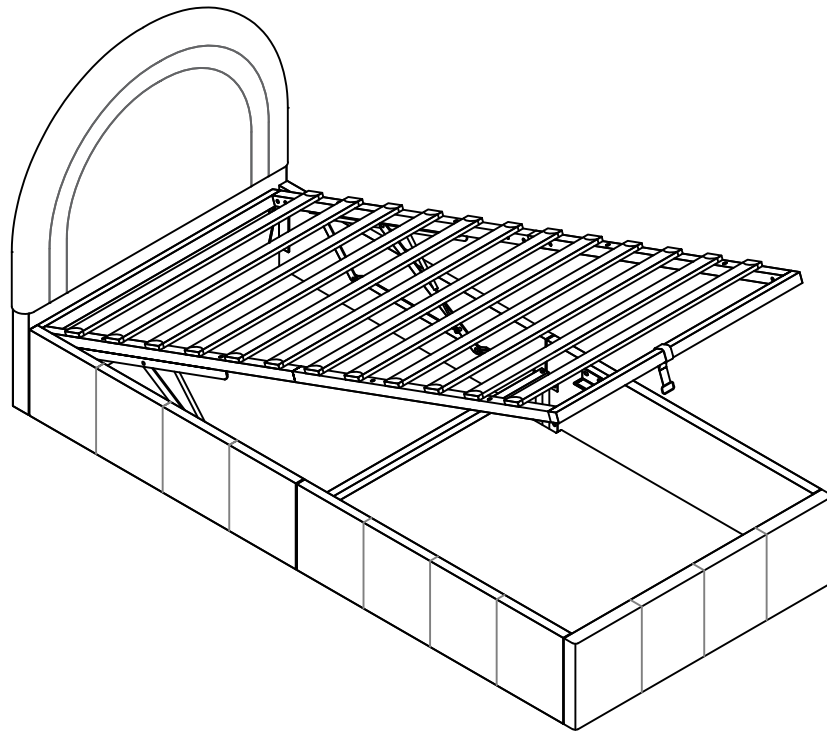

DE:Unser Produkt wird Ihnen in 2 Paketen geliefert. Die Lieferzeiten dieser 2 Pakete können abweichen, bitte haben Sie etwas Geduld und vielen Dank für Ihr Verständnis.

UK:Our product will be delivered to you in 2 packages. The delivery times of these 2 packages may differ, please be patient and thank you for your understanding.

FR:Notre produit vous sera livré en 2 colis. Les délais de livraison de ces 2 colis peuvent différer, soyez patient et merci pour votre compréhension.

## English

### IMPORTANT FOR GAS LIFT BEDS&MAINTAINANCE

- Please place the mattress on top of the bed frame.
- Please do not pull on the strap handles.
- Please press heavily to release the compressed gas.
- Periodically check all screw & fixings to ensure they are secure.
- When moving your product, carefully lift into place.
- Wipe clean with a slightly damp cloth- please do not use abrasive chemicals or bleach.
- Do NOT allow children to operate the lift mechanism.
- Do NOT allow children near the lift base when operating the mechanism.
- Do NOT stand inside the bed or the internal storage base.
- Do NOT overload the internal storage base.
- DO NOT jump on the product or any of its parts.

## Deutsch

### WICHTIG FÜR GASLIFT-BETTEN&WARTUNG

- Bitte legen Sie die Matratze oben auf den Bettrahmen.
- Bitte ziehen Sie nicht an den Gurtgriffen.
- Bitte drücken Sie kräftig, um das komprimierte Gas freizusetzen.
- Überprüfen Sie regelmäßig alle Schrauben und Befestigungen, um sicherzustellen, dass sie sicher sind.
- Wenn Sie Ihr Produkt bewegen, heben Sie es vorsichtig an seinen Platz.
- Mit einem leicht feuchten Tuch abwischen - bitte keine scheuernden Chemikalien oder Bleichmittel verwenden.
- Erlauben Sie Kindern NICHT, den Hebemechanismus zu bedienen.
- Lassen Sie Kinder NICHT in die Nähe des Liftsockels, wenn Sie den Mechanismus bedienen.
- Stellen Sie sich NICHT in das Bett oder in die Innenablage.
- Überlasten Sie den internen Liftsockel NICHT.
- Springen Sie NICHT auf das Produkt oder eines seiner Teile.

## Français

### IMPORTANT POUR LES LITS À RELEVAGE DE GAZ&MAINTENANCE

- Veuillez placer le matelas sur le dessus du cadre de lit.
- Ne tirez pas sur les poignées de la sangle.
- Appuyez fortement pour libérer le gaz comprimé.
- Vérifiez régulièrement que toutes les vis et fixations sont bien en place.
- Lorsque vous déplacez votre produit, soulevez-le avec précaution pour le mettre en place.
- Nettoyez avec un chiffon légèrement humide - n'utilisez pas de produits chimiques abrasifs ou d'eau de Javel.
- Ne laissez pas les enfants utiliser le mécanisme de levage.
- Ne laissez pas les enfants s'approcher de la base de levage lorsqu'ils actionnent le mécanisme.
- Ne vous tenez PAS à l'intérieur du lit ou de la base de stockage interne.
- Ne surchargez pas la base de stockage interne.
- Ne pas sauter sur le produit ou l'une de ses parties.

## Italiano

### IMPORTANTE PER I LETTI CON SOLLEVAMENTO A GAS E LA MANUTENZIONE

- Posizionare il materasso sopra la struttura del letto.
- Non tirare le maniglie della cinghia.
- Premere con forza per rilasciare il gas compresso.
- Controllare periodicamente tutte le viti e i fissaggi per assicurarsi che siano saldi.
- Quando si sposta il prodotto, sollevarlo con cautela.
- Pulire con un panno leggermente umido, senza usare prodotti chimici abrasivi o candeggina.
- NON permettere ai bambini di azionare il meccanismo di sollevamento.
- NON permettere ai bambini di avvicinarsi alla base di sollevamento quando si aziona il meccanismo.
- NON sostare all'interno del letto o della base di contenimento interna.
- NON sovraccaricare la base di contenimento interna.
- NON saltare sul prodotto o sulle sue parti.

## Español

### IMPORTANTE PARA LAS CAMAS ELEVADORAS DE GAS&MANTENIMIENTO

- Coloque el colchón sobre el somier.
- No tire de las asas de la correa.
- Presione con fuerza para liberar el gas comprimido.
- Compruebe periódicamente que todos los tornillos y fijaciones estén bien sujetos.
- Al mover el producto, levántelo con cuidado para colocarlo en su sitio.
- Limpie con un paño ligeramente humedecido; no utilice productos químicos abrasivos ni lejía.
- NO permita que los niños accionen el mecanismo de elevación.
- NO permita que los niños se acerquen a la base elevadora cuando accionen el mecanismo.
- NO se ponga de pie dentro de la cama o de la base de almacenamiento interna.
- NO sobrecargue el somier.
- NO salte sobre el producto ni sobre ninguna de sus piezas.





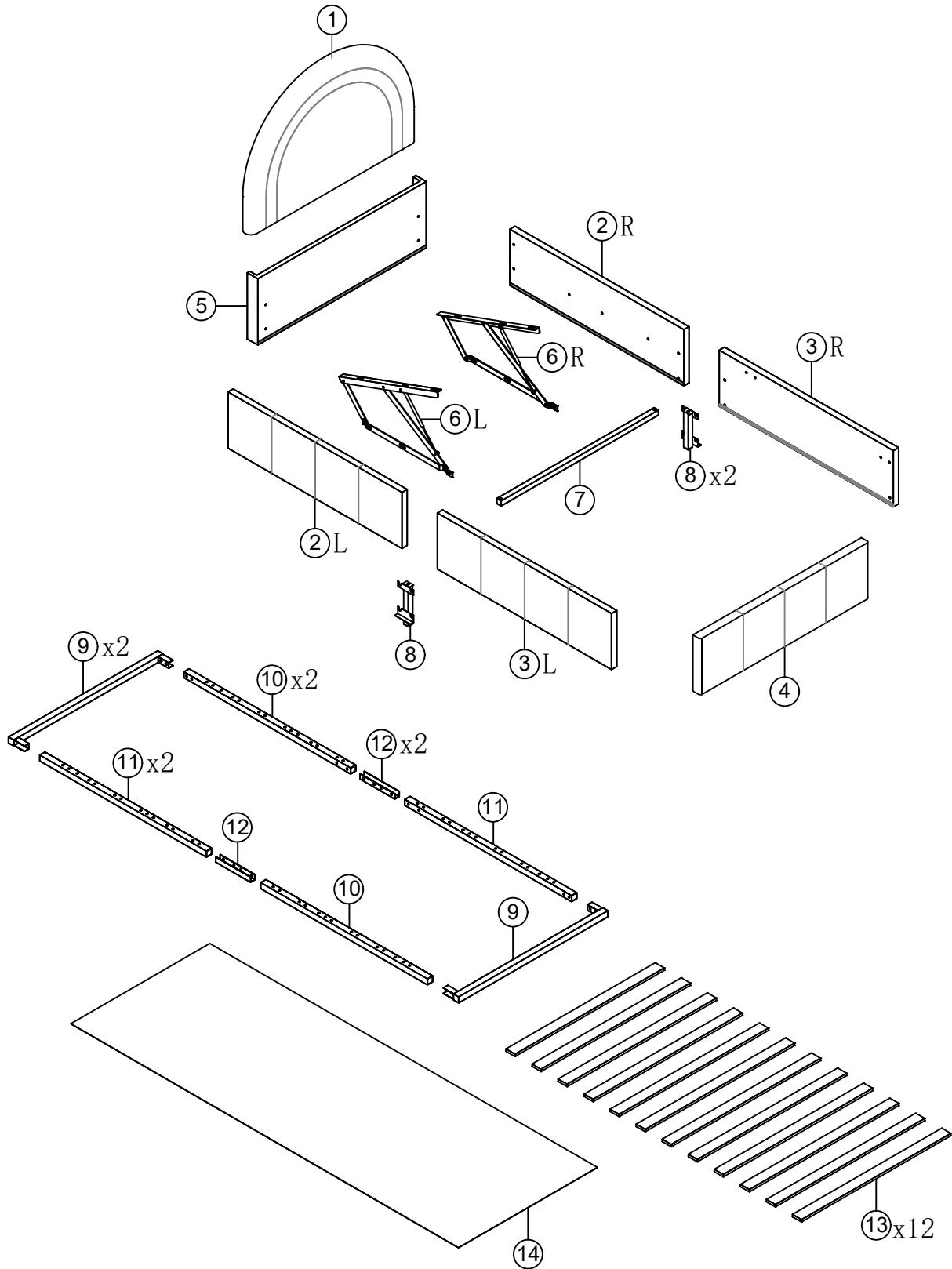

# Stückliste

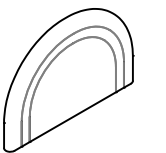
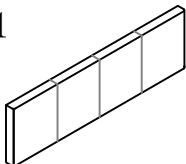
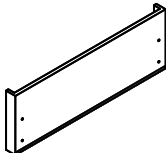

# Part List

(Liste der Einzelteile)

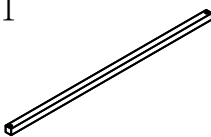
## N634P433762

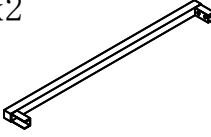
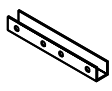
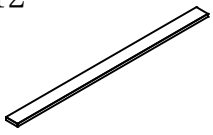
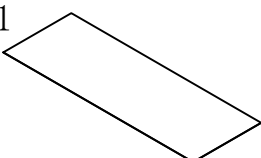



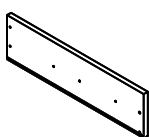
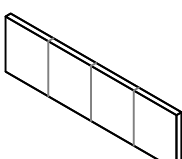
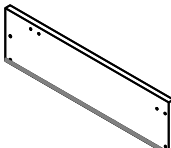
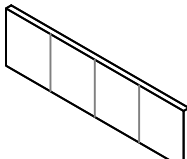
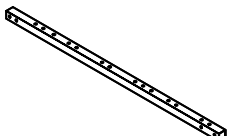
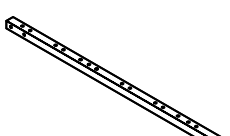





① x1 	④ x1 	⑤ x1 	⑥R x1 
Top head board (Oberkopfteil)	Foot board (Fußteil)	Base head board (Unterkopfteil)	Gas lift (Gasdruckfeder)
⑥L x1 	⑦ x1 	⑧ x2 	⑨ x2 
Gas lift (Gasdruckfeder)	Metal cross bar (Metallquerstrebe)	Side rails support legs (Stützbeine für Seitenschienen)	Metal frame cross bar (Metallrahmen Querstange)
⑫ x2 	⑬ x12 	⑭ x1 	
Connection fitting (Anschlussbeschlag)	Slat (Latte)	Black non woven fabric (Schwarzer Vliesstoff)	

## N634P433763

②R x1 	②L x1 	③R x1 	③L x1 
Side rail (Seitenschienen)	Side rail (Seitenschienen)	Side rail (Seitenschienen)	Side rail (Seitenschienen)
⑩ x2 	⑪ x2 		
Metal frame side bar (Seitenleiste mit Metallrahmen)	Metal frame side bar (Seitenleiste mit Metallrahmen)		

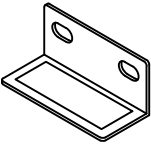
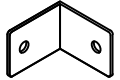
# Hardware list (Hardwareliste)

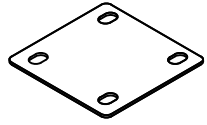
N634P433762

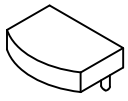
Ax1 	Bx66  M8x18mm	Cx6  M8x45mm
Allen Key (Inbusschlüssel)	Bolts (Schrauben)	Bolts (Schrauben)
Dx4 	Ex4 	Fx1 
Nuts (Mutter)	Nuts (Mutter)	Spanner (Schraubenschlüssel)
Gx2 	Hx2 	Ix2 
Hinge (Scharnie)	"7" Connector ("7" Steckverbinder)	Little "7" Connector (Kleiner "7"-Anschluss)
Jx2 	Kx2 	Lx1 
Metal Corner (Metall-Ecken)	Four hole iron (Eisen mit vier Löchern)	Four hole iron (Eisen mit vier Löchern)
Mx1 	Nx24 	
Pull tape (Zugband)	End slats cap (Abdeckung für Endlatten)	

**DE:** Vor dem Einbau die Schrauben in die Löcher stecken und festziehen, aber nicht bis 100%, 70% bis 80% anziehen reicht aus. Schließlich, nachdem alle Schrauben installiert sind, ziehen Sie alle Schrauben auf 100%.

Wenn Sie auf diese Probleme stoßen, wie z. B. Fehlausrichtung der Löcher oder Unfähigkeit, bestimmte Teile zu installieren, überprüfen Sie bitte, ob die Schrauben korrekt verwendet werden und passen Sie die Dichtigkeit der Schrauben an.

**UK:** Before installation, insert the screws into the holes and tighten them, but do not tighten them to 100%, 70% to 80% is sufficient. Finally, after all screws are installed, tighten all screws to 100%.

If you encounter these issues, such as if the holes cannot be aligned or some parts cannot be installed, please check if the screws are used correctly and adjust the tightness of the screws.

**FR:** Insérer la vis dans le trou avant la fin de l'assemblage, serrer la vis, mais ne pas serrer à 100%, 70% ~ 80% est correct. Enfin, une fois que toutes les vis sont bien serrées, toutes les vis sont serrées à 100%.

Si vous rencontrez ces problèmes, par exemple si les trous ne sont pas alignés ou si certaines pièces ne peuvent pas être montées, vérifiez que les vis sont utilisées correctement et Ajustez leur serrage.

Attention: Do not tighten the screws before completing the entire installation. If you have any difficulty with the installation process, please feel free to contact us.





(Achtung: Ziehen Sie die Schrauben erst fest, wenn die gesamte Installation abgeschlossen ist. Wenn Sie beim Installationsvorgang Schwierigkeiten haben, können Sie sich gerne an uns wenden.)

### Step 1:

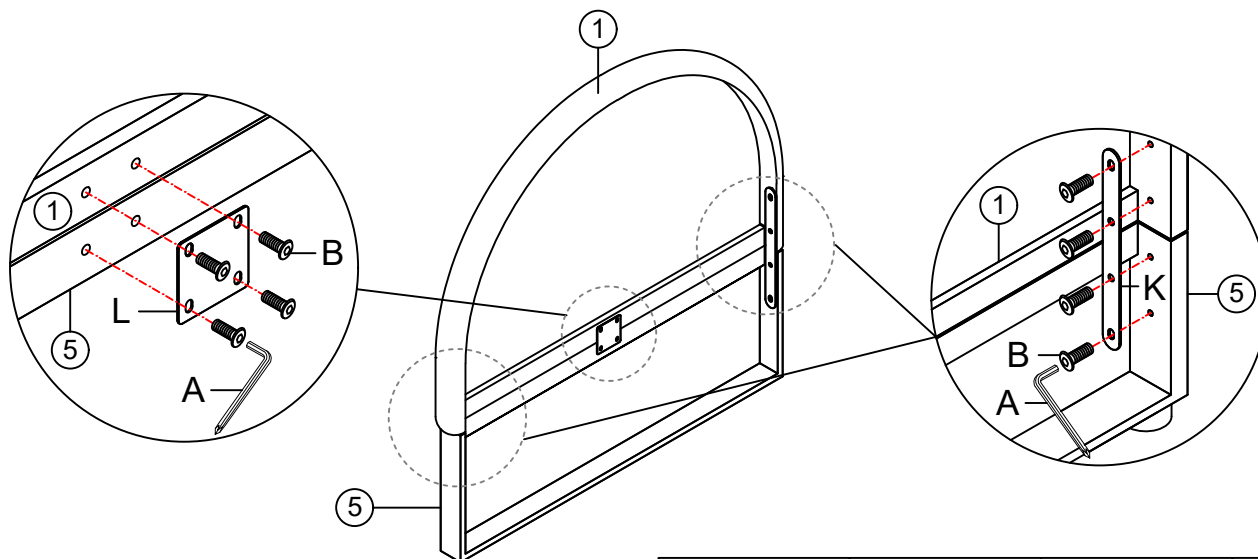
Fix the Base head board (5) to the Top head board (1) with Bolts B, Four hole iron K and L by using Allen key A.

(Befestigen Sie die Basiskopfplatte (5) mit einem Innensechskantschlüssel A an der oberen Kopfplatte (1) mit den Schrauben B und dem Vierlocheisen K und L.)





A Allen Key 	B Bolts x 12 M8x18mm 	K Four hole iron x 2 	L Four hole iron x 1 
--	--	---	---

### Step 2:

Fix the Side rails support legs (8) to the Side rail (2) and (3) with Bolts B by using Allen key A.

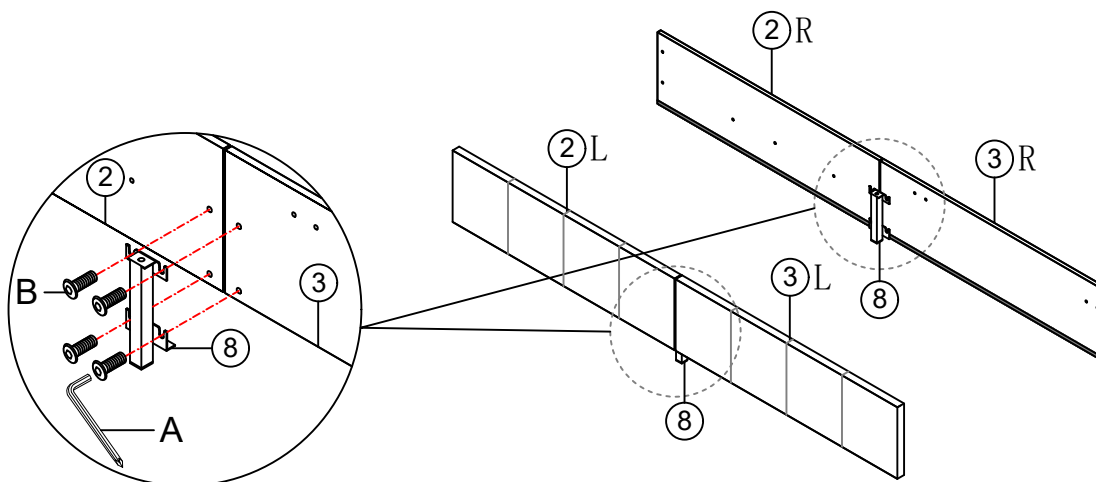
(Befestigen Sie die Seitenschielenstützbeine (8) mit Schrauben B mit Hilfe eines Innensechskantschlüssels A an den Seitenschielen (2) und (3).)



A Allen Key 	B Bolts x 8 M8x18mm 
--	---

### Step 3:

Fix the Side rail (2) to the Base head board (5) with Bolts B and Hinge G by using Allen key A.

(Verwenden Sie einen Innensechskantschlüssel A und befestigen Sie die Seitenschiene (2) mit den Bolzen B und dem Scharnier G an der Sockelkopfplatte (5).)

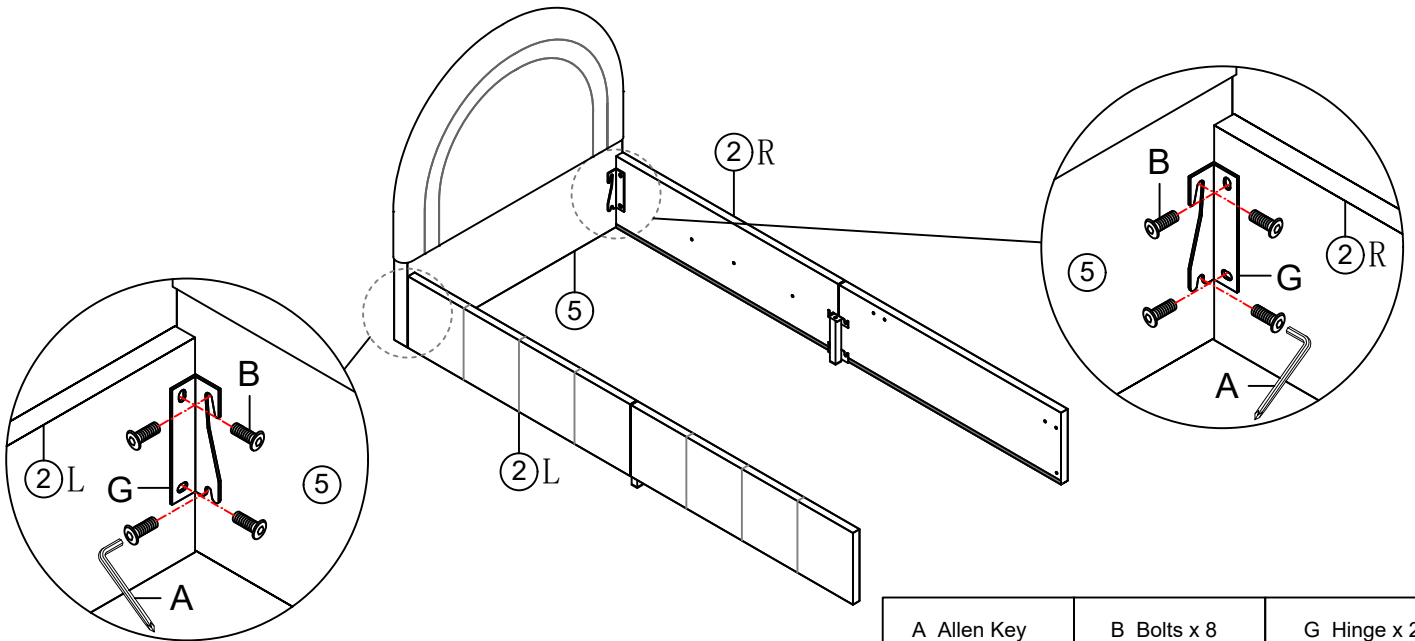

A Allen Key



B Bolts x 8



G Hinge x 2



### Step 4:

Fix the Foot board (4) to the Side rail (3) with Bolts B, Little "7" Connector I and Metal Corner J by using Allen key A.

(Befestigen Sie die Fußplatte (4) mit dem Innensechskantschlüssel A mit dem Bolzen B, dem kleinen "7"-Gelenk I und dem Metallwinkel J an der Seitenschiene (3).)

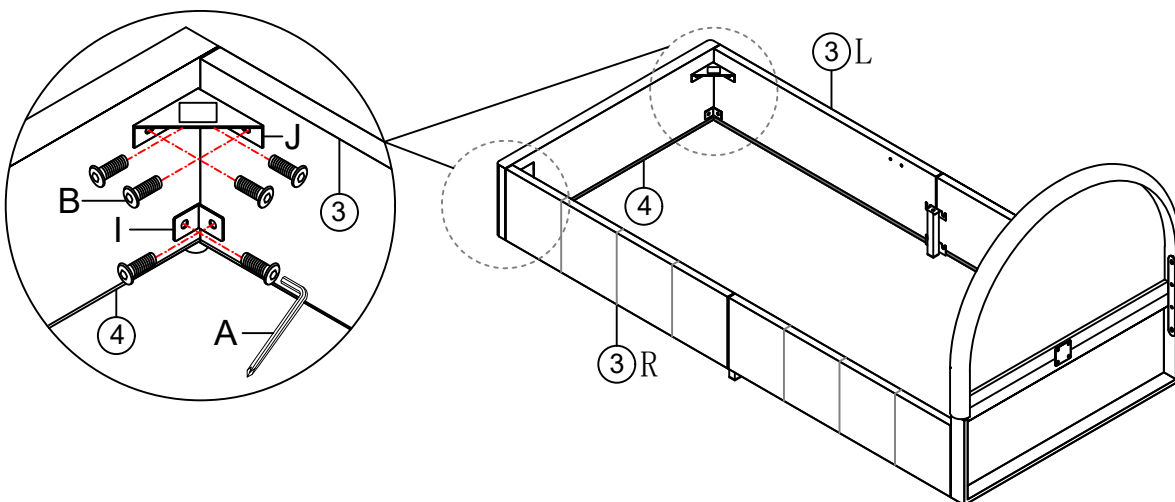

A Allen Key



B Bolts x 12



I Little "7" Connector x 2



J Metal Corner x 2



## Step5:

Stick the Black non woven fabric (14) to the side rail (2), side rail (3), Foot board (4) and Base head board (5).

(Kleben Sie den schwarzen Vliesstoff (14) auf die Seitenleiste (2), die Seitenleiste (3), die Fußplatte (4) und die Basiskopfplatte (5).)

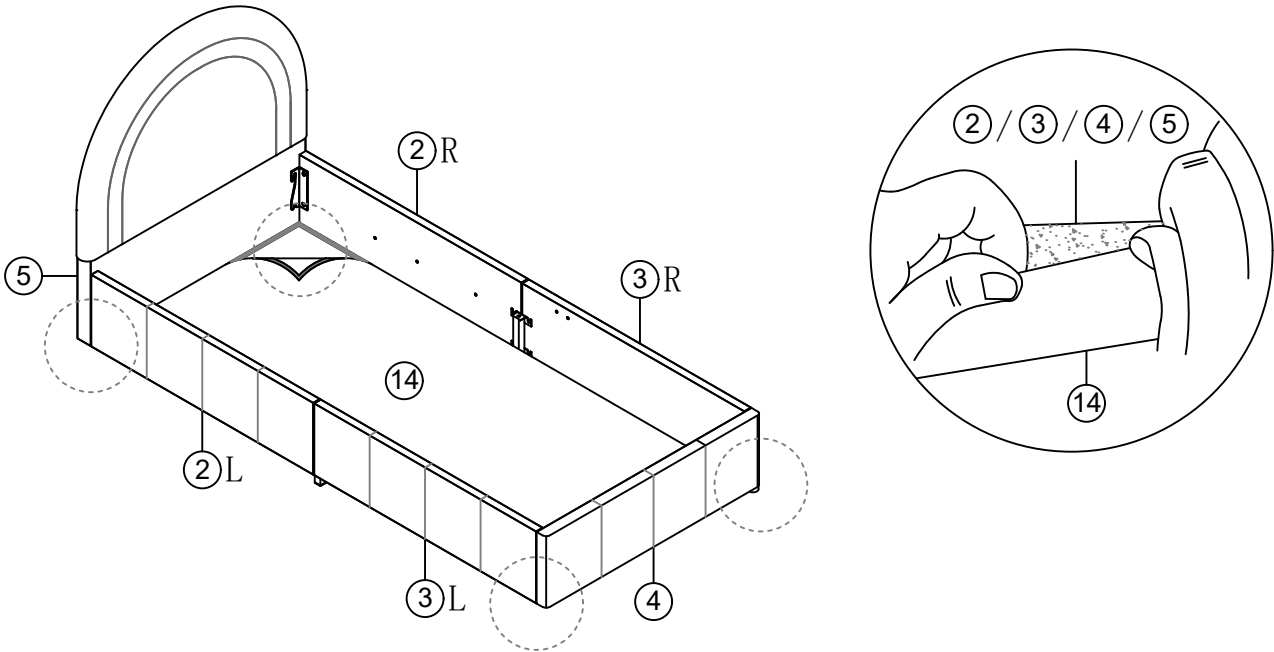

## Step6:

Fix the Metal cross bar (7) to the Side rails support legs (8) with Bolts C by using Allen key A.

(Befestigen Sie die metallische Querstange (7) mit Schrauben C mit Hilfe eines Innensechskantschlüssels A an den Seitenschienenstützbeinen (8).)

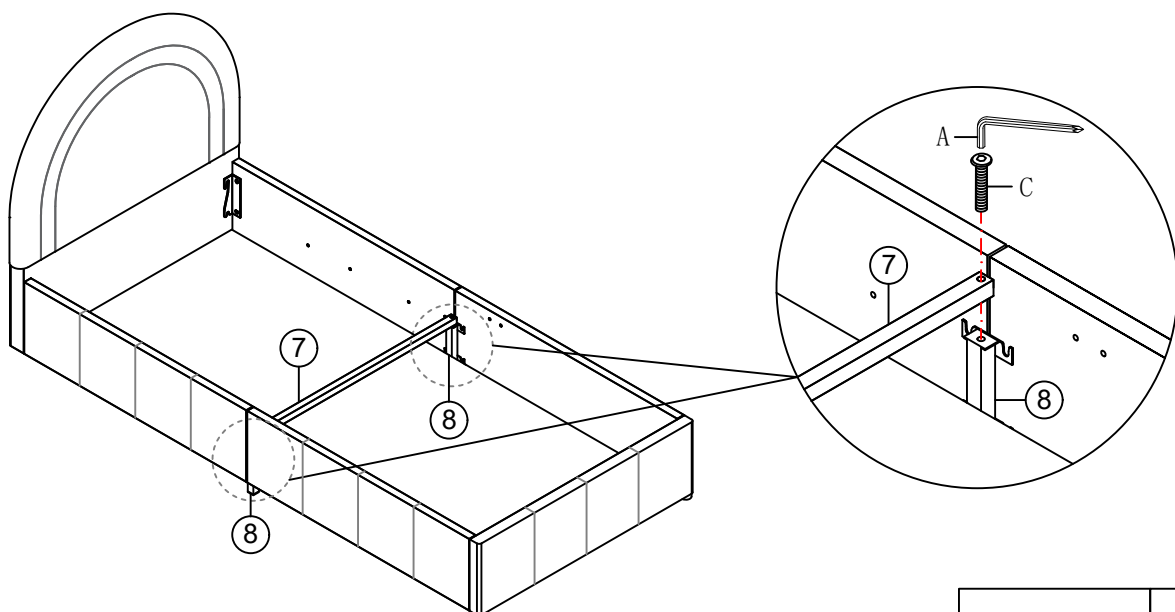

A Allen Key



C Bolts x 2







M8x45mm

## Step7:

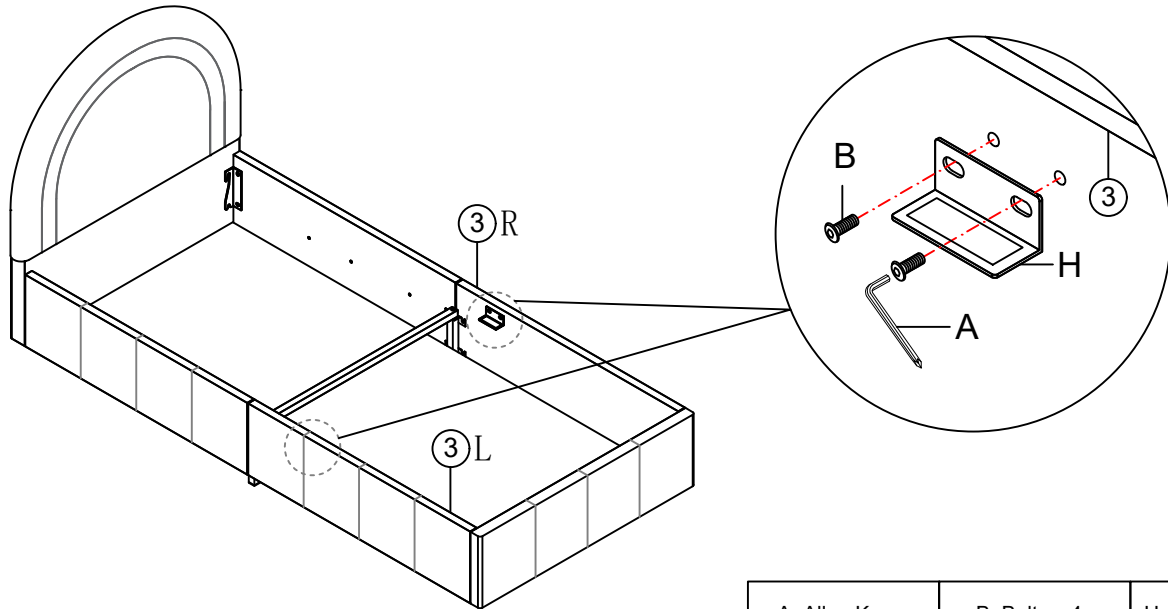
Fix the "7" Connector H to the Side rail ③ with Bolts B by using Allen key A.

(Verwenden Sie einen Innensechskantschlüssel A, um das "7"-Gelenk H mit dem Bolzen B an der Seitenschiene ③ zu befestigen.)







A Allen Key 	B Bolts x 4 M8x18mm 	H "7" Connector x 2 
---	---	--

## Step8:

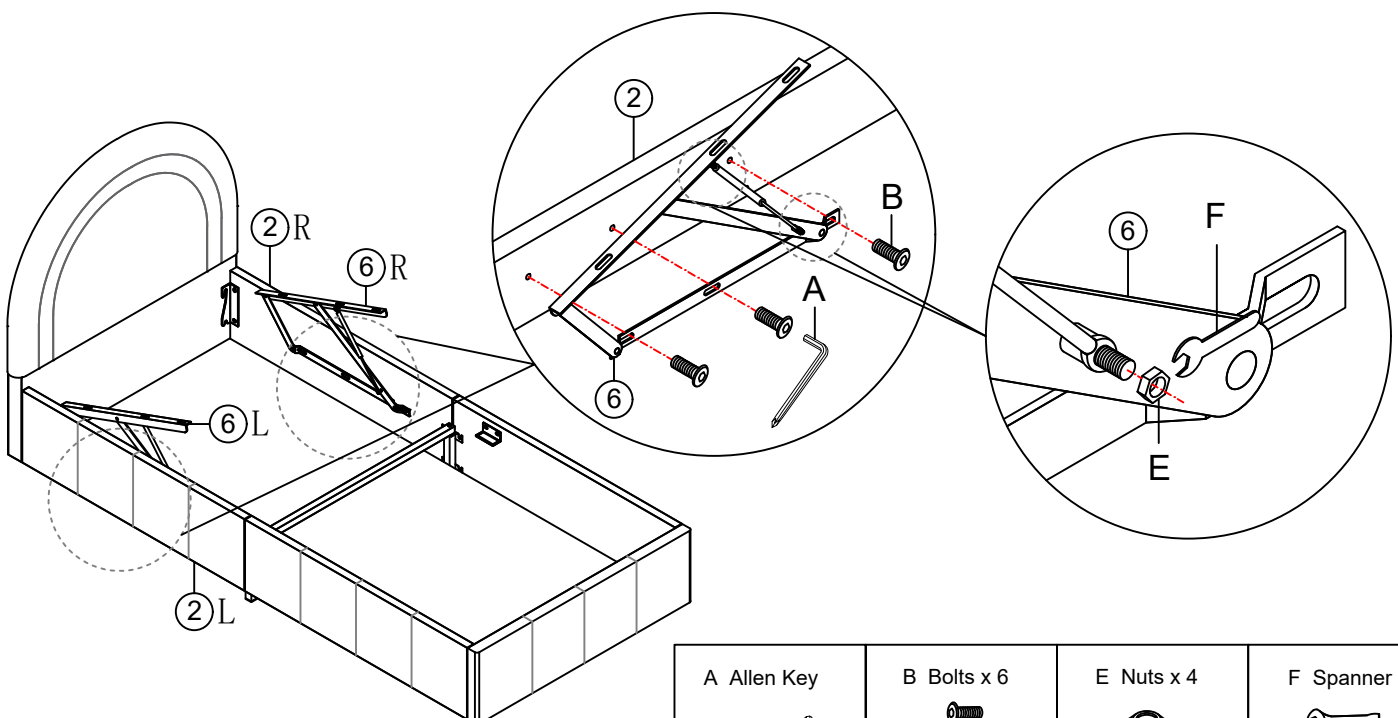
Fix the Gas lift ⑥ to the Side rail ② with Bolts B and Nuts E by using Allen key A and Spanner F.

(Verwenden Sie den Innensechskantschlüssel A und den Schlüssel F und befestigen Sie den Gaslift ⑥ mit Schrauben B und Muttern E an der Seitenschiene ②.)



A Allen Key 	B Bolts x 6 M8x18mm 	E Nuts x 4 	F Spanner 
--	---	---	--

## Step9:

Fix the Metal frame side bar ⑩ and ⑪ together with the Connection fitting ⑫ and Bolts B by using Allen Key A.  
(Befestigen Sie die Metallrahmenseitenstangen ⑩ und ⑪ mit dem Verbindungsarmatur ⑫ und den Schrauben B mit einem Innensechskantschlüssel A.)

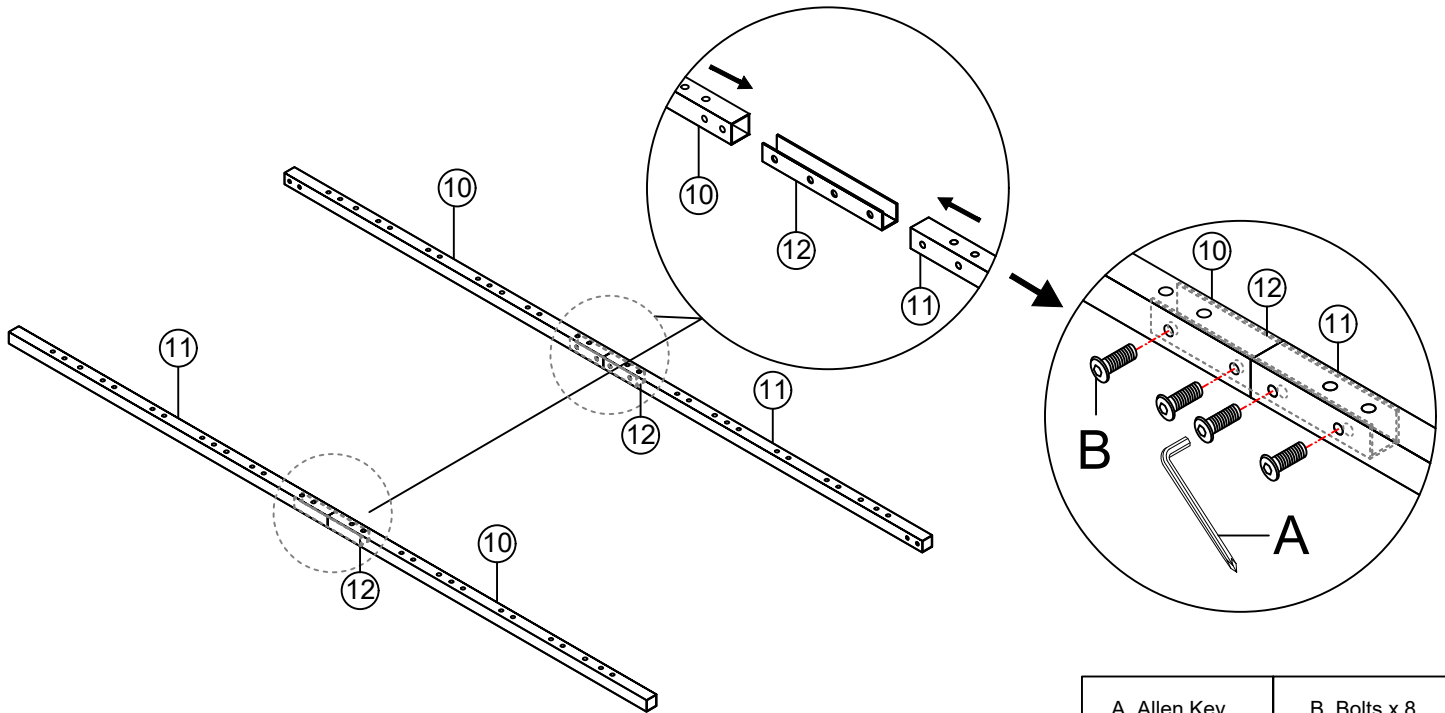

A Allen Key



B Bolts x 8



M8x18mm

## Step10:

Fix the Metal frame cross bar ⑨ to the Metal frame side bar ⑩ and ⑪ with Bolts B by using Allen key A .  
(Befestigen Sie die Metallrahmenquerstange ⑨ mit dem Innensechskantschlüssel a mit den Schrauben B an den Metallrahmenseitenstangen ⑩ und ⑪.)

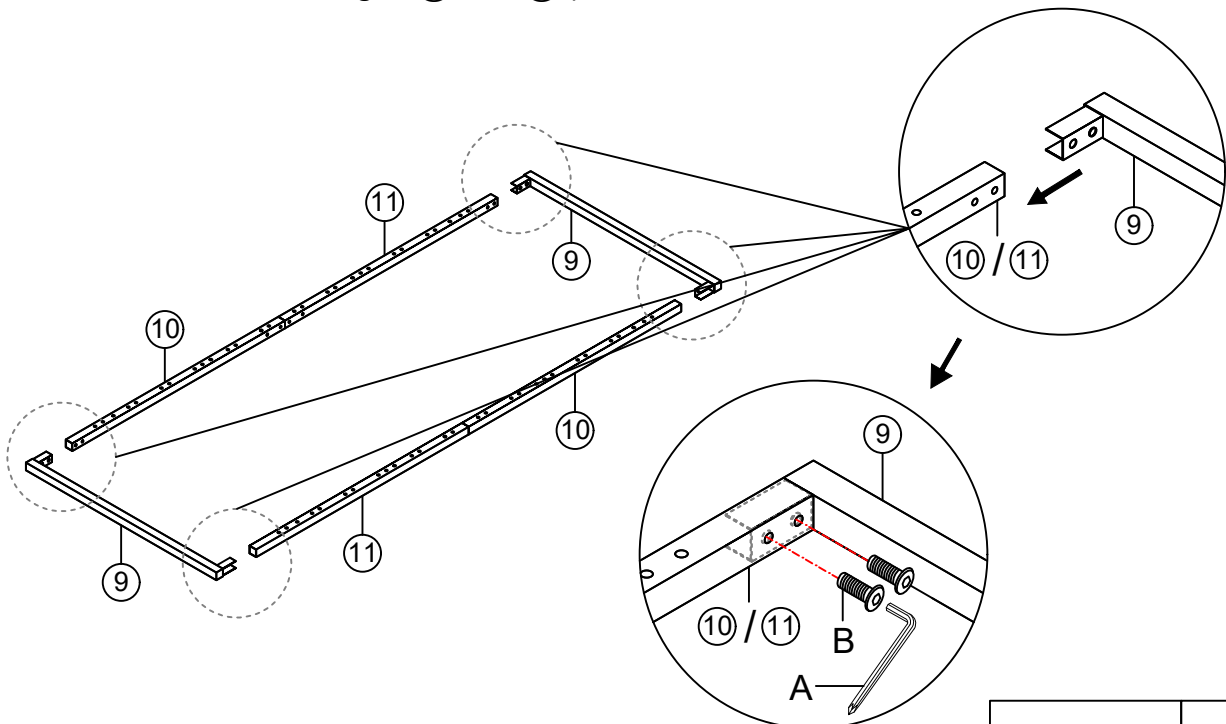

A Allen Key



B Bolts x 8



M8x18mm

## Step11:

Assemble the slats into the assembled slats frame with End slats cap N.

(Die Lamellen werden mit den Endlattenabdeckungen N in den zusammengebauten Lamellenrahmen montiert.)

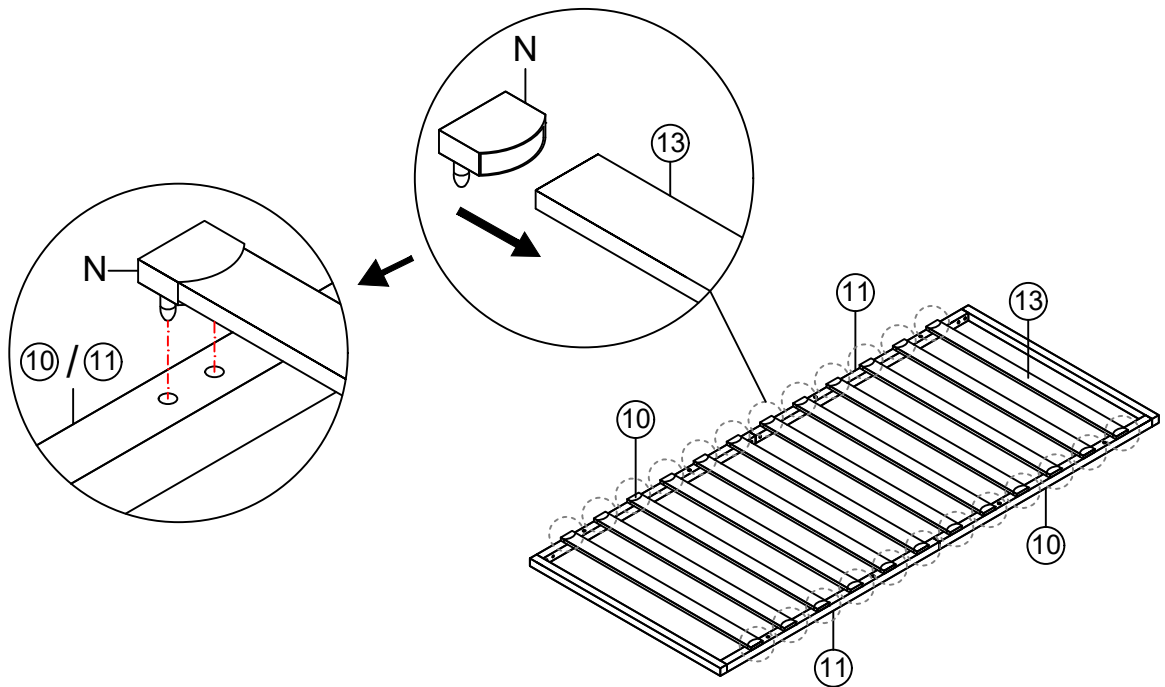

N End slats cap x 24



## Step12:

Fix the assembled slats frame to the Gas lift (6) with Bolts C and Nuts D by using Allen key A and Spanner F.

Put the pull tape M in side middle of the slat frame.

(Befestigen Sie den zusammengebauten Lattenrahmen mit Schrauben C und Muttern D mit

Innensechskantschlüssel A und Schraubenschlüssel F am Gaslift (6). Legen Sie den Zugriff M in der Seitenmitte des Lattenrahmens.)

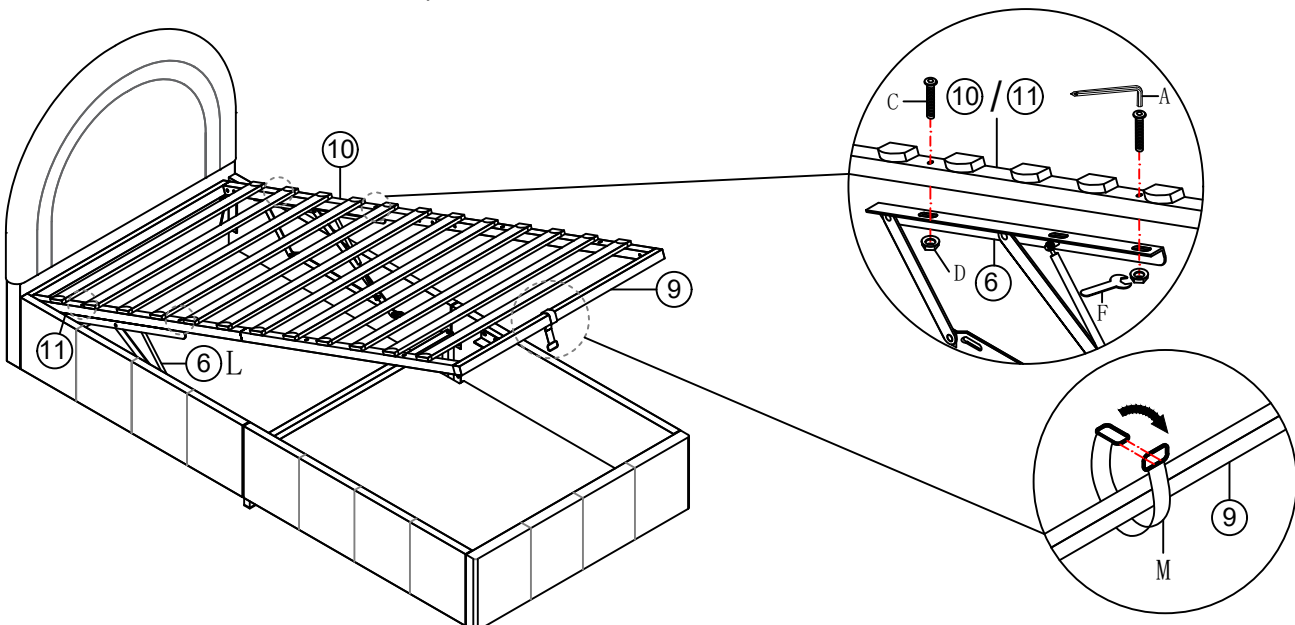

A Allen Key



C Bolts x 4



D Nuts x 4



F Spanner



M Pull tape x 1



## Step13:

Every thing is finished now,please enjoy your bed.  
(Jetzt ist alles vorbei, bitte genießen Sie Ihr Bett.)

