

# MONTAGEANLEITUNG//ASSEMBLY INSTRUCTION

Artikel nummer/Item Number: N622P370124G

## Küchenspielset Aus Holz 90x30x98CM

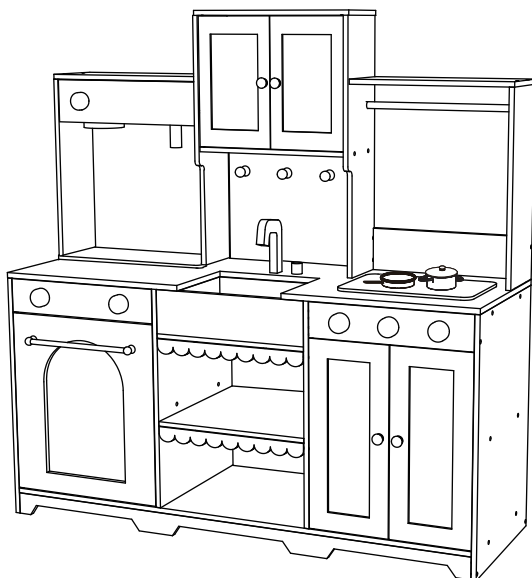

Importeur	Decobus Handel GmbH
Adresse	Innungsstraße 9, 21244 Buchholz, Deutschland
URL	<a href="https://www.decobusgroup.de">https://www.decobusgroup.de</a>
Hersteller	NINGDE PAINTED TOYS CO.,LTD.
Adresse	Xixi Jiwu Industrial Concentration zone, Shouning County, Ningde City, Fujian Province, China
Email/URL	<a href="mailto:lillianye177@163.com">lillianye177@163.com</a>
Partienummer	C429NPA20250814HE
Hergestellt in	CHINA
EC REP	Decobus Handel GmbH Innungsstraße 9, 21244 Buchholz, Deutschland <a href="https://www.decobusgroup.de">https://www.decobusgroup.de</a>

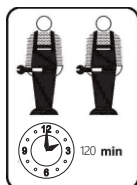

### English

**IMPORTANT ! KEEP FOR FUTURE REFERENCE : READ CAREFULLY**

- To be assembled by an adult. Assembly must be checked by an adult before use.
- **WARNING !** Keep all screws, small parts and plastic bags out of the reach of children.
- Properly identify all parts before assembling.
- Anchor unit to stud or wall.
- Always use on a level, even surface.
- Avoid the risk of fire by not placing toy near sources of ignition or hot items.
- **DO NOT** place hot or cold items directly onto the surface.
- **DO NOT** place the item next to a radiator or direct sunlight.
- **DO NOT** allow children to climb on unit.
- **DO NOT** put the product in a humid environment.

### Deutsch

**WICHTIG ! ZUM SPÄTEREN NACHSCHLAGEN AUFBEWAHREN: SORGFÄLTIG LESEN**

- Muss von einem Erwachsenen zusammengebaut werden. Der Zusammenbau muss vor der Benutzung von einem Erwachsenen überprüft werden.
- **WARNUNG!** Bewahren Sie alle Schrauben, Kleinteile und Plastikbeutel außerhalb der Reichweite von Kindern auf.
- Kennzeichnen Sie vor dem Zusammenbau alle Teile ordnungsgemäß.
- Verankern Sie das Gerät an einem Ständer oder einer Wand.
- Benutzen Sie das Gerät immer auf einer ebenen, geraden Fläche.
- Vermeiden Sie das Risiko eines Brandes, indem Sie die Spielzeug nicht in der Nähe von Zündquellen oder heißen Gegenständen aufstellen.
- Stellen Sie **KEINE** heißen oder kalten Gegenstände direkt auf die Oberfläche.
- Stellen Sie das Gerät **NICHT** in der Nähe eines Heizkörpers oder direkter Sonneneinstrahlung auf.
- Erlauben Sie Kindern **NICHT**, auf das Gerät zu klettern.
- Stellen Sie das Gerät **NICHT** in einer feuchten Umgebung auf.

### Français

**IMPORTANT ! CONSERVER POUR RÉFÉRENCE ULTÉRIEURE : LIRE ATTENTIVEMENT**

- A assembler par un adulte. Le montage doit être vérifié par un adulte avant utilisation.
- **ATTENTION !** Conservez toutes les vis, les petites pièces et les sacs en plastique hors de portée des enfants.
- Identifiez correctement toutes les pièces avant de les assembler.
- Fixer l'appareil à un montant ou à un mur.
- Utilisez toujours l'appareil sur une surface plane et uniforme.
- Évitez les risques d'incendie en ne plaçant pas le jouet à proximité de sources d'inflammation ou d'objets chauds.
- **NE PAS** placer d'objets chauds ou froids directement sur la surface.
- **NE PAS** placer l'appareil à côté d'un radiateur ou de la lumière directe du soleil.
- **NE PAS** laisser les enfants grimper sur l'appareil.
- **NE PAS** placer le produit dans un environnement humide.

Italiano

**IMPORTANTE! CONSERVARE PER RIFERIMENTO FUTURO: LEGGERE ATTENTAMENTE**

- Deve essere assemblato da un adulto. L'assemblaggio deve essere controllato da un adulto prima dell'uso.
- AVVERTENZA ! Tenere tutte le viti, le piccole parti e i sacchetti di plastica fuori dalla portata dei bambini.
- Identificare correttamente tutte le parti prima dell'assemblaggio.
- Ancorare l'unità a un pilastro o a una parete.
- Utilizzare sempre su una superficie piana e uniforme.
- Evitare il rischio di incendio non collocando i giocattoli vicino a fonti di accensione o ad oggetti caldi.
- NON collocare oggetti caldi o freddi direttamente sulla superficie.
- NON collocare l'apparecchio vicino a un termosifone o alla luce diretta del sole.
- NON permettere ai bambini di arrampicarsi sull'unità.
- NON collocare il prodotto in un ambiente umido.

Español

**¡ IMPORTANTE ! CONSÉRVELO PARA FUTURAS CONSULTAS: LEA ATENTAMENTE**

- Debe montarlo un adulto. El montaje debe ser comprobado por un adulto antes del uso.
- ADVERTENCIA Mantenga todos los tornillos, piezas pequeñas y bolsas de plástico fuera del alcance de los niños.
- Identifique correctamente todas las piezas antes del montaje.
- Ancle la unidad a un montante o pared.
- Utilí celo siempre sobre una superficie plana y nivelada.
- Evite el riesgo de incendio no colocando los juguete cerca de fuentes de ignición o artículos calientes.
- NO coloque objetos calientes o fríos directamente sobre la superficie.
- NO coloque el mueble cerca de un radiador o de la luz solar directa.
- NO permita que los niños se suban a la unidad.
- NO coloque el producto en un ambiente húmedo.



[DE]

**Warnung:** Dieses Produkt ist nicht für Kinder unter 36 Monaten geeignet.

**Warnung:** Aufgrund der Kleinteile sollten Kinder das Produkt nur unter Aufsicht von Erwachsenen verwenden, um die Gefahr des Verschluckens zu vermeiden.

**Warnung:** Um die Sicherheit zu gewährleisten, befolgen Sie bitte die Anweisungen zur korrekten Installation und holen Sie sich bei Bedarf professionelle Hilfe.

**Warnung:** Stellen Sie Spielzeug nicht in der Nähe von Feuerquellen oder Gegenständen mit hoher Temperatur auf, um Brandgefahr zu vermeiden.

[EN]

**Warning:** Not suitable for children under 36 months.

**Warning:** Due to the small parts of the product, children should only use it under adult supervision to avoid a swallowing hazard.

**Warning:** To ensure safety, please follow the instructions for correct installation and seek professional assistance if necessary.

**Warning:** Do not place toy close to fire sources or high-temperature objects to avoid the risk of fire.

[FR]

**Avertissement :** Ce produit ne convient pas aux enfants de moins de 36 mois.

**Avertissement :** En raison des petites pièces du produit, les enfants ne doivent l'utiliser que sous la surveillance d'un adulte afin d'éviter tout risque d'ingestion.

**Avertissement :** Pour garantir la sécurité, veuillez suivre les instructions pour une installation correcte et demander l'aide d'un professionnel si nécessaire.

**Avertissement :** Ne placez pas les jouet à proximité de sources d'incendie ou d'objets à haute température pour éviter tout risque d'incendie.

[IT]

**Attenzione:** Questo prodotto non è adatto ai bambini di età inferiore ai 36 mesi.

**Attenzione:** A causa delle piccole parti del prodotto, i bambini devono utilizzarlo solo sotto la supervisione di un adulto per evitare il rischio di soffocamento.

**Attenzione:** Per garantire la sicurezza, seguire le istruzioni per una corretta installazione e, se necessario, richiedere assistenza professionale.

**Attenzione:** Non posizionare i giocattoli vicino a fonti di fuoco o oggetti ad alta temperatura per evitare il rischio di incendio.

[ES]

**Advertencia:** Este producto no es adecuado para niños menores de 36 meses.

**Advertencia:** Debido a las pequeñas piezas del producto, los niños sólo deben utilizarlo bajo la supervisión de un adulto para evitar el riesgo de asfixia.

**Advertencia:** Para garantizar la seguridad, siga las instrucciones para una instalación correcta y busque asistencia profesional si es necesario.

**Advertencia:** No coloque juguete cerca de fuentes de fuego u objetos de alta temperatura para evitar el riesgo de incendio.

# Stückliste

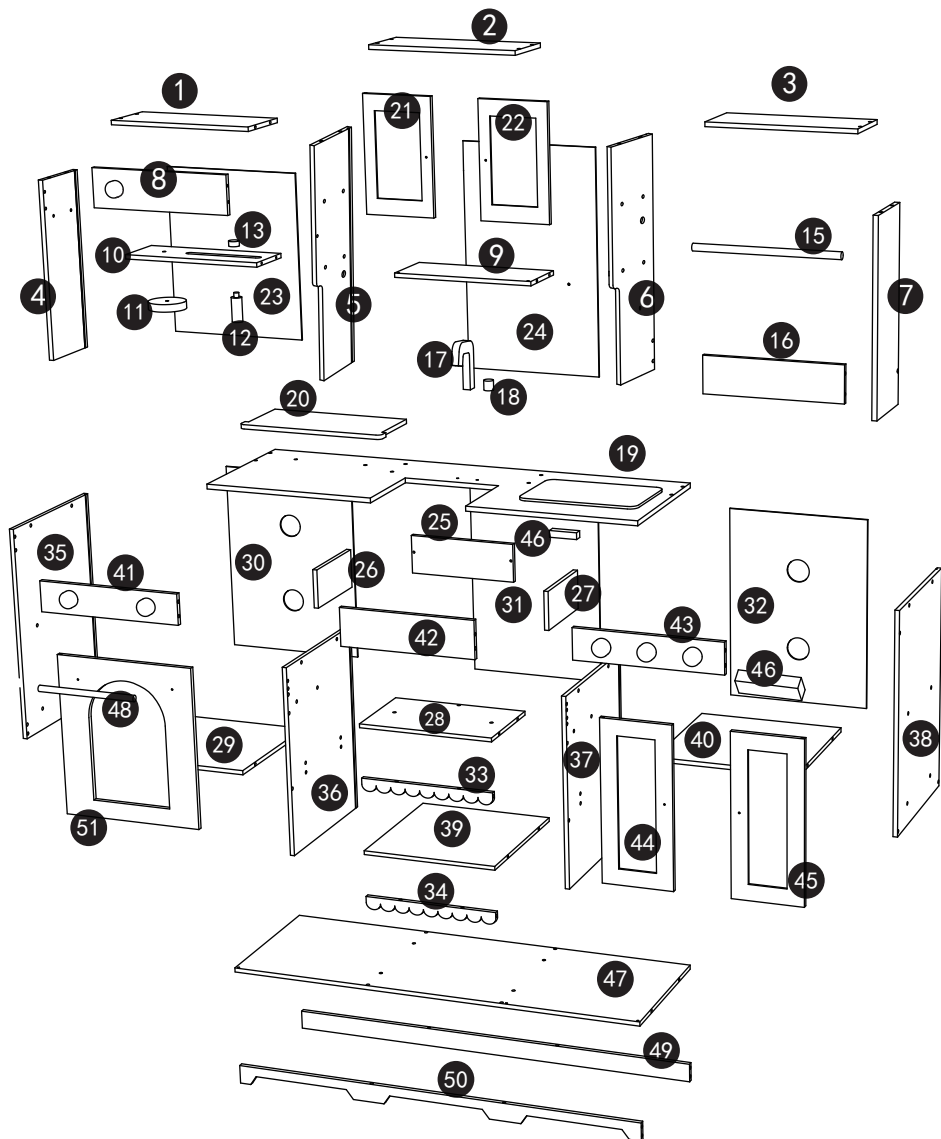

1 x1 	2 x1 	3 x1 	
4 x1 	5 x1 	6 x1 	7 x1 
8 x1 	9 x1 	10 x1 	11 x1 
12 x1 	13 x1 	14 x3 	15 x1 
16 x1 	17 x1 	18 x1 	20 x1 
19 x1 	21 x1 	22 x1 	
23 x1 	24 x1 	25 x1 	27 x1 
		26 x1 	28 x1 

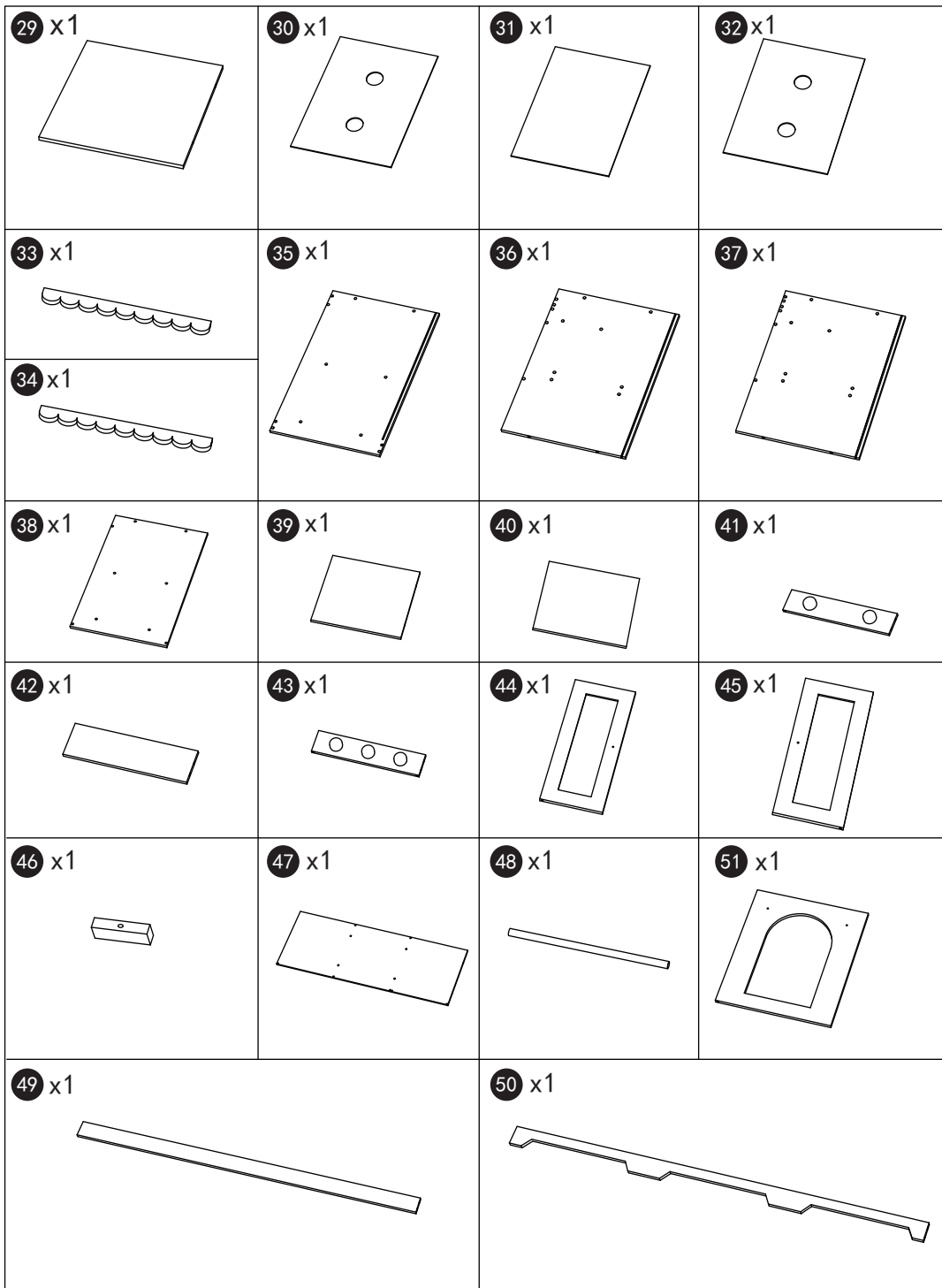



 M4x35 Ax67	 M4x25 Bx11	 M4x20 Cx12	 M4x10 Dx8	 M3x8 Ex40	 M3x14 Fx3
 M4x16 Gx2	 M5x30 Hx22	 Ix5	 Jx5	 Kx5	 Lx8
 Mx5	 M4x16 Ox4	 ax2	 bx4	 cx1	 dx1
 fx1					

Schritt 1 	C	 M4X20	2
	E	 M3X8	4
	M	 Mx5	1
	I	 Ix5	1
Schritt 2 	O	 M4X16	2
	E	 M3X8	12
	M	 Mx5	2
	J	 Jx5	2
	I	 Ix5	2
Schritt 3 	E	 M3X8	8
	M	 Mx5	2
	I	 Ix5	1
	O	 M4X16	2
	J	 Jx5	1

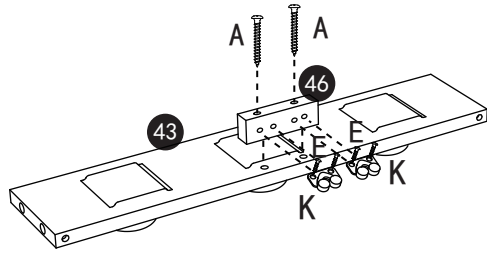

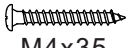
Schritt 4

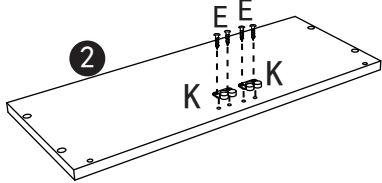

A	 2
K	 2
E	 4

Schritt 5



K	 2
E	 4

Schritt 6

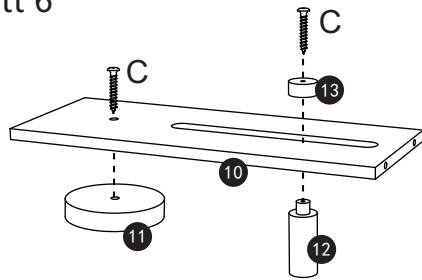

C	 2

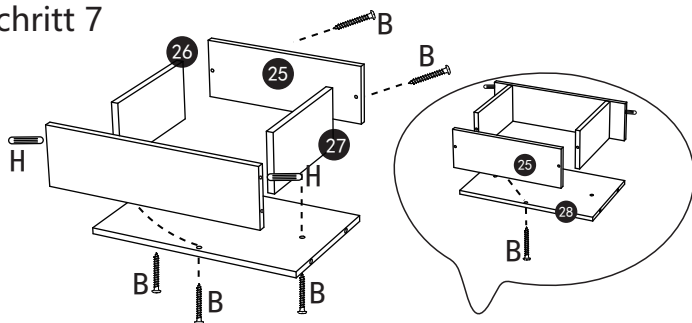

Schritt 7

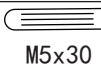

B	 6
H	 2

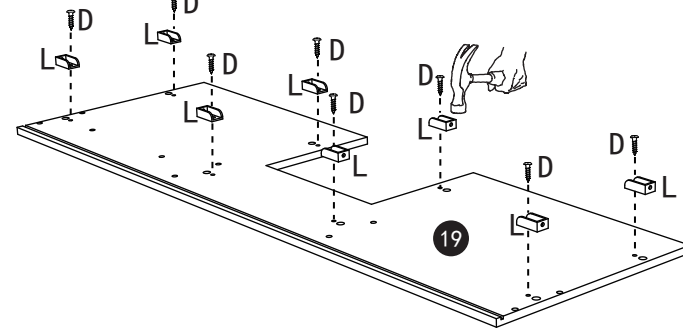
Schritt 8



D	 8
L	 8

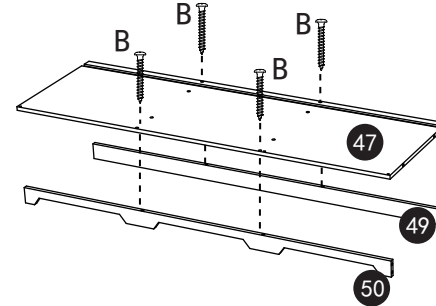

Schritt 9

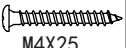

B	 2

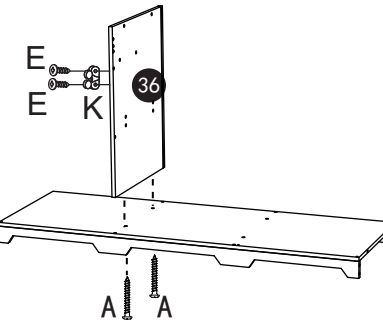

Schritt 10

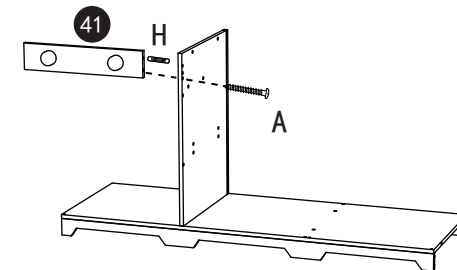

A	 2
K	 1
E	 2

Schritt 11

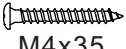

A	 1
H	 1

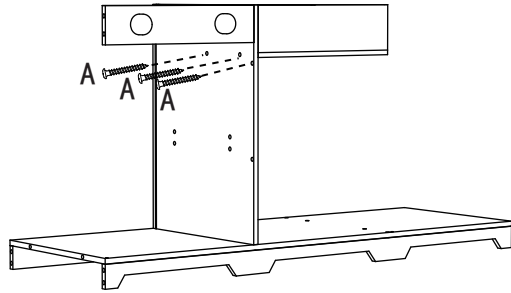

### Schritt 12

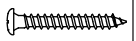

A	 M4x35	3

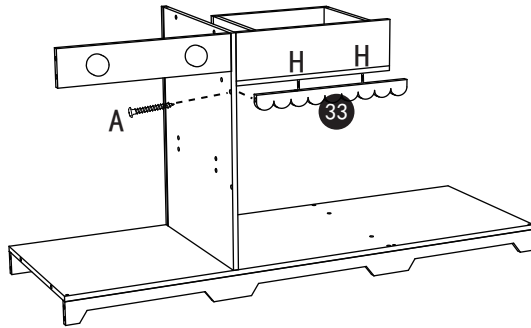
### Schritt 13

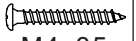

A	 M4x35	1
H	 M5x30	2

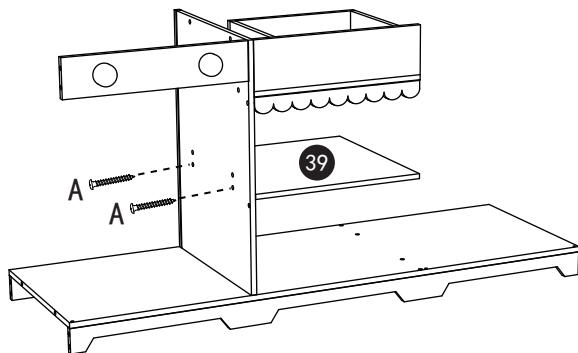

### Schritt 14

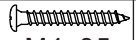

A	 M4x35	2

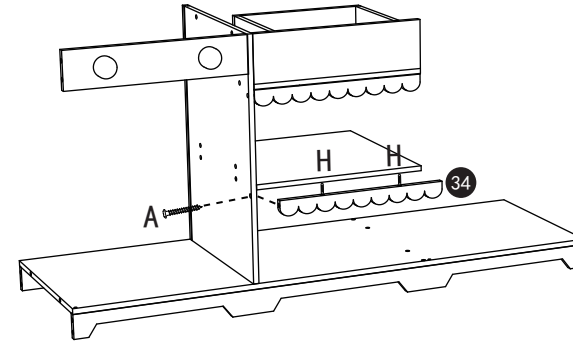

### Schritt 15

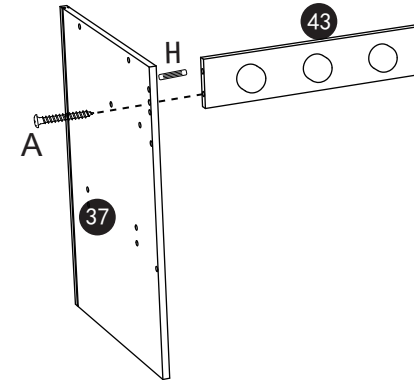

A	 M4x35	1
H	 M5x30	2

### Schritt 16

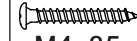

A	 M4x35	1
H	 M5x30	1

### Schritt 17

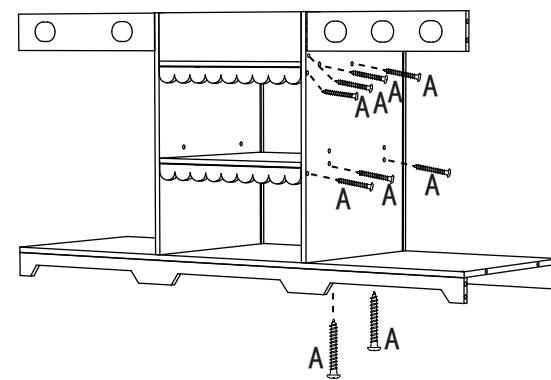

A	 M4x35	9

Schritt 18

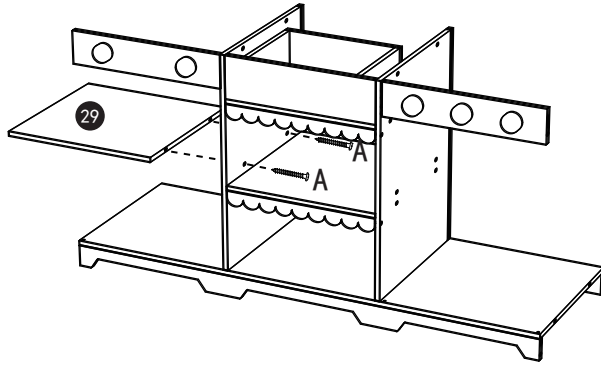

A	M4x35	2

Schritt 19

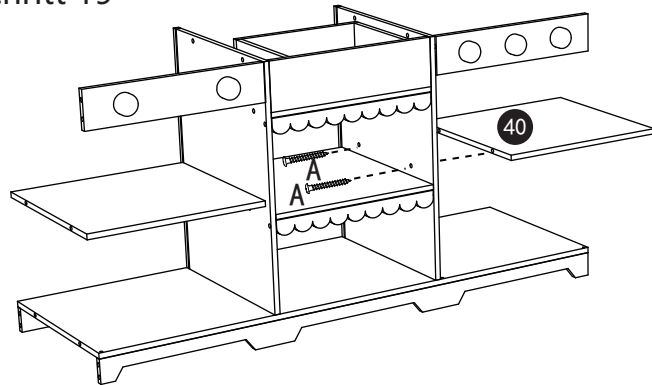

A	M4x35	2

Schritt 20

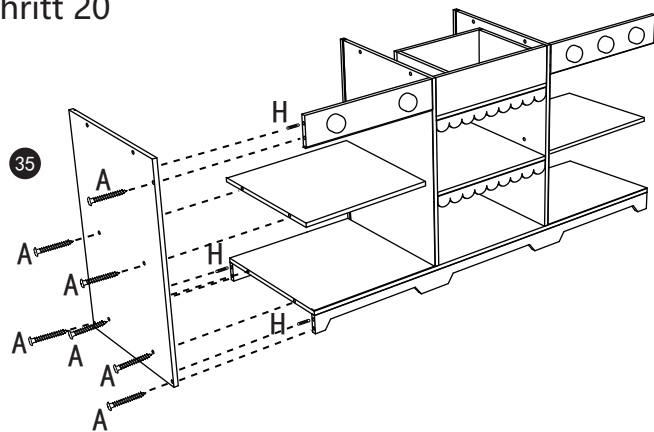

A	M4x35	7
H	M5x30	3

Schritt 21

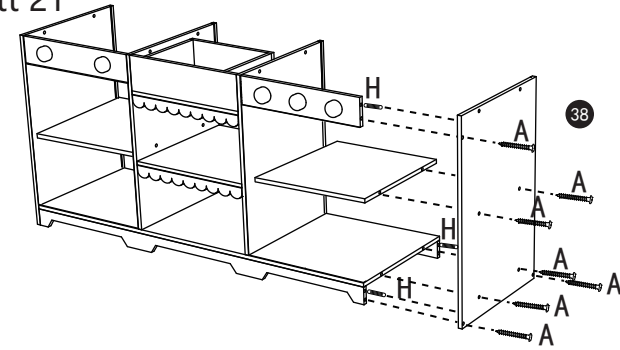

A	M4x35	7
H	M5x30	3

Schritt 22

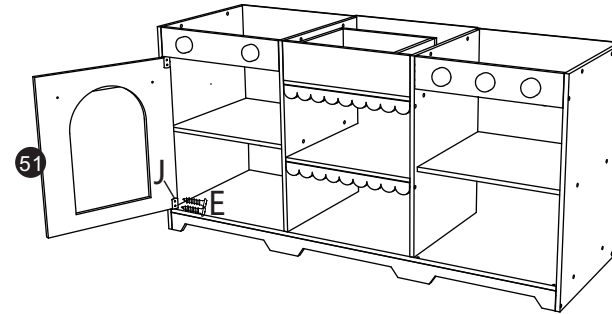

E	M3x8	2
J		1

Schritt 23

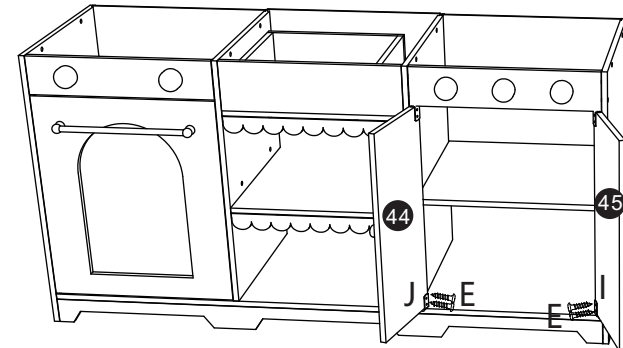

E	M3x8	4
I		1
J		1

Schritt 24

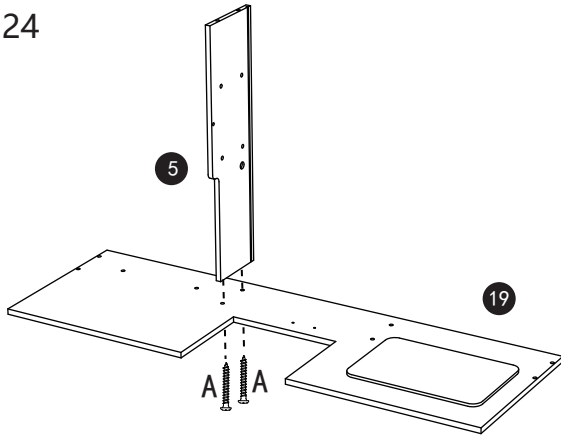

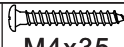
A  M4x35 2

Schritt 27

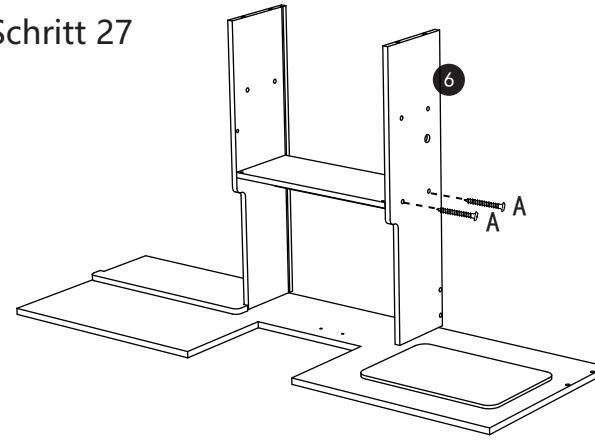

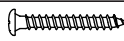
A  M4x35 2

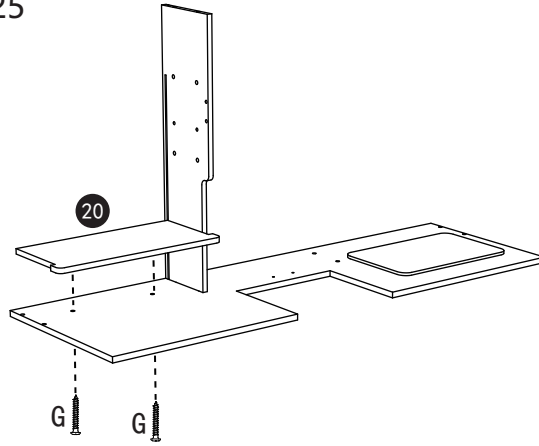

Schritt 25

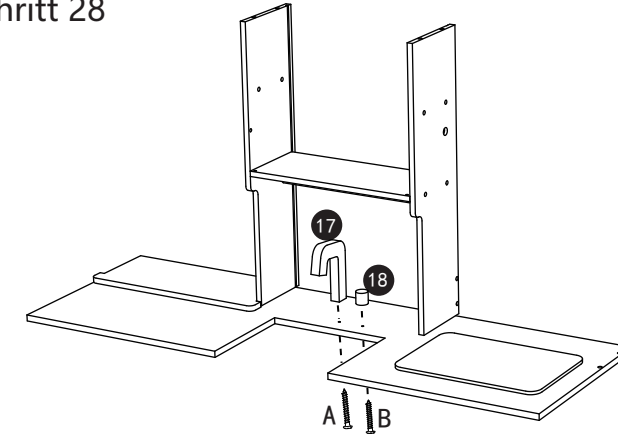

G  M4x16 2

Schritt 28

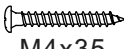
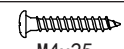

A  M4x35 1  
B  M4x25 1

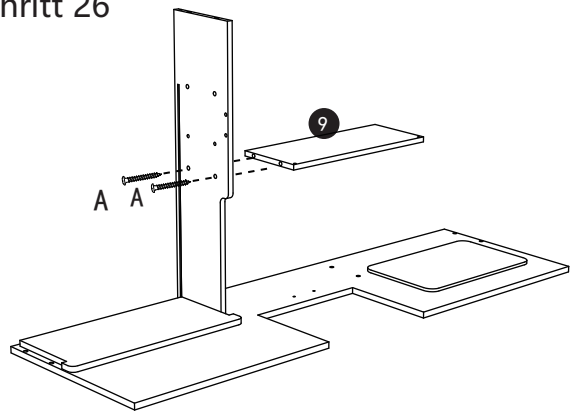

Schritt 26

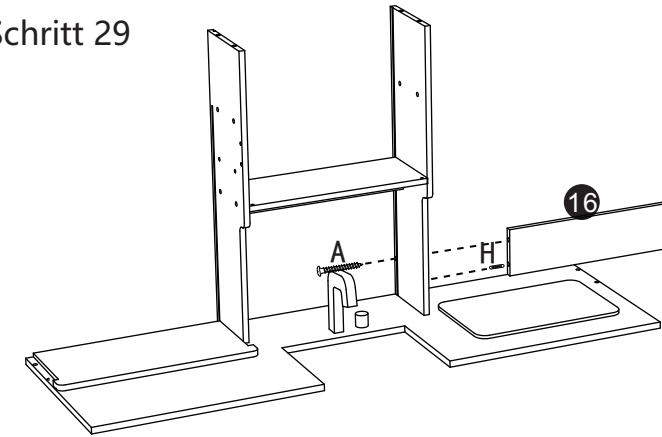

A  M4x35 2

Schritt 29

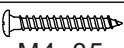

A  M4x35 1  
H  M5x30 1

### Schritt 30

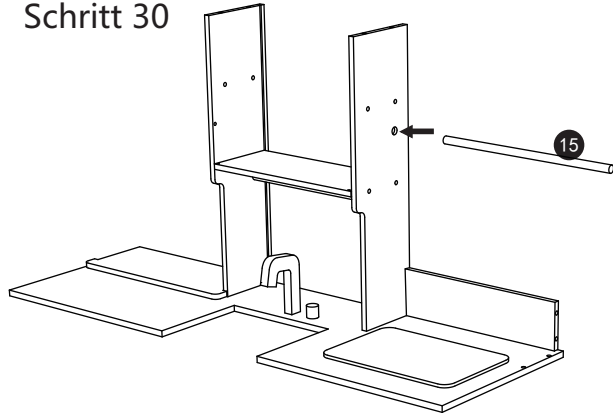

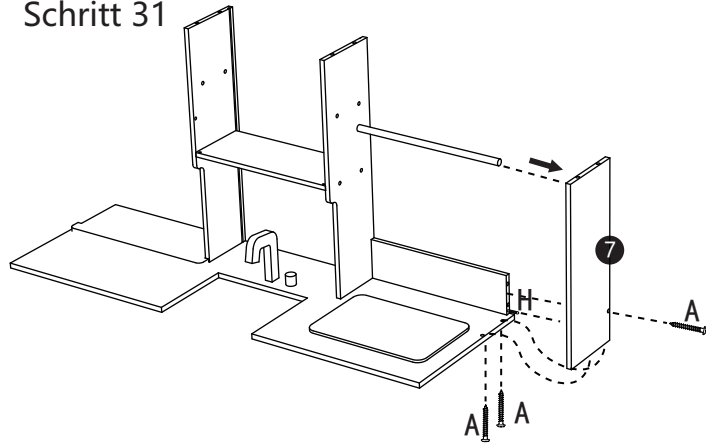

### Schritt 31

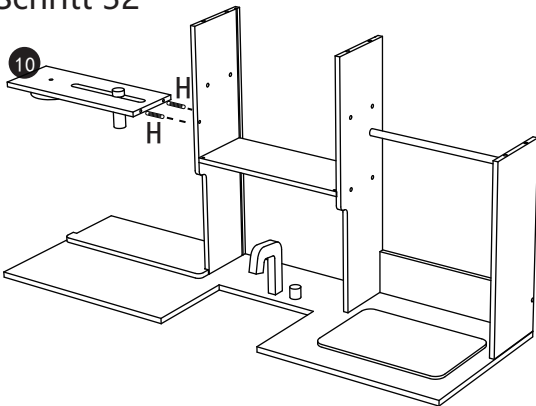

A	M4x35	3
H	M5x30	1

### Schritt 32



H	M5x30	2

### Schritt 33

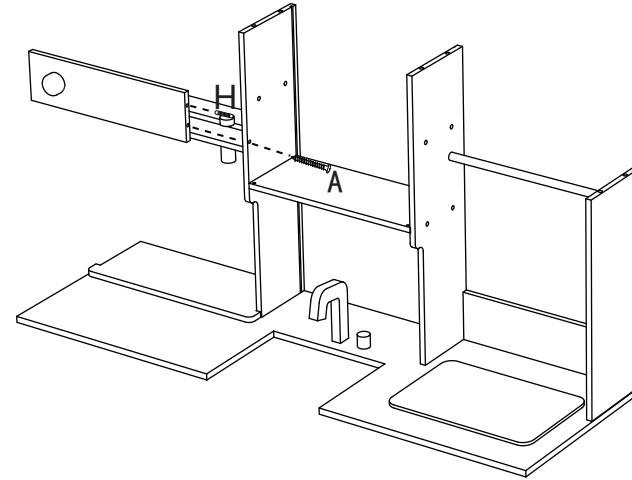

A	M4x35	1
H	M5x30	1

### Schritt 34

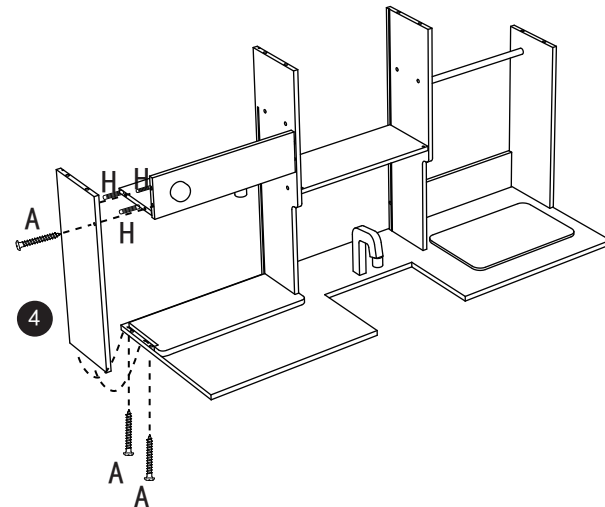

A	M4x35	3
H	M5x30	3

### Schritt 35

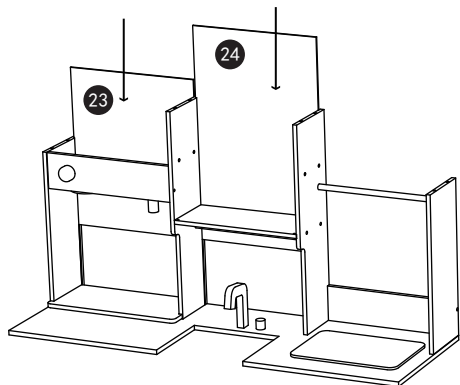

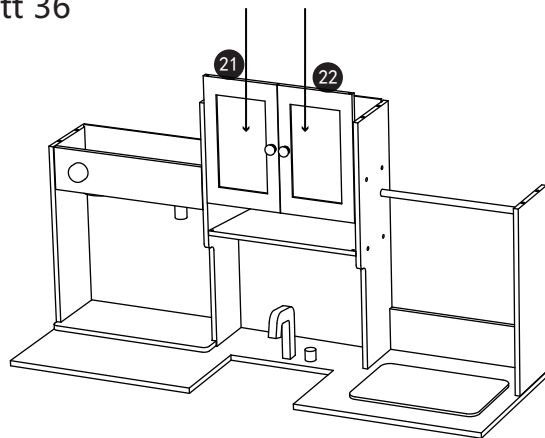

### Schritt 36



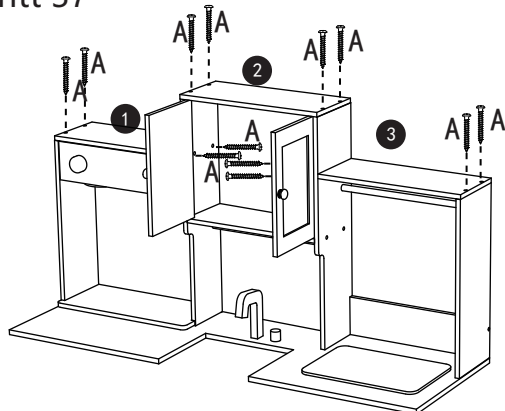

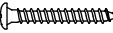
### Schritt 37



A  M4x35 12

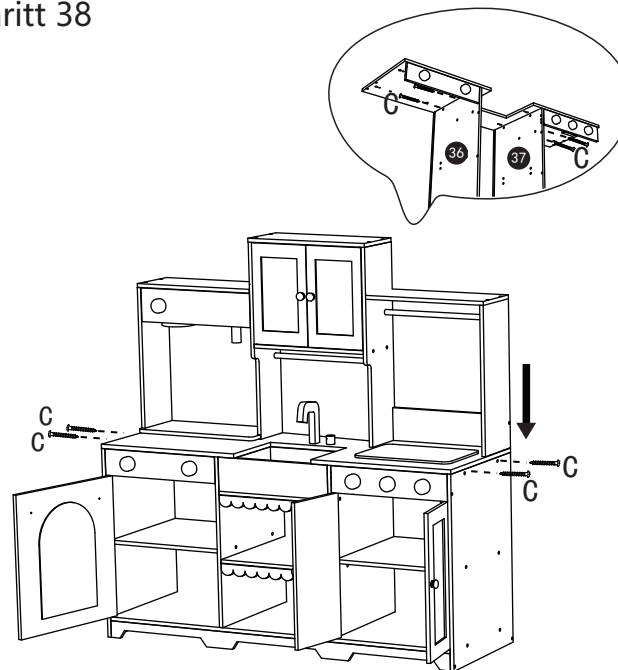

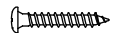
### Schritt 38

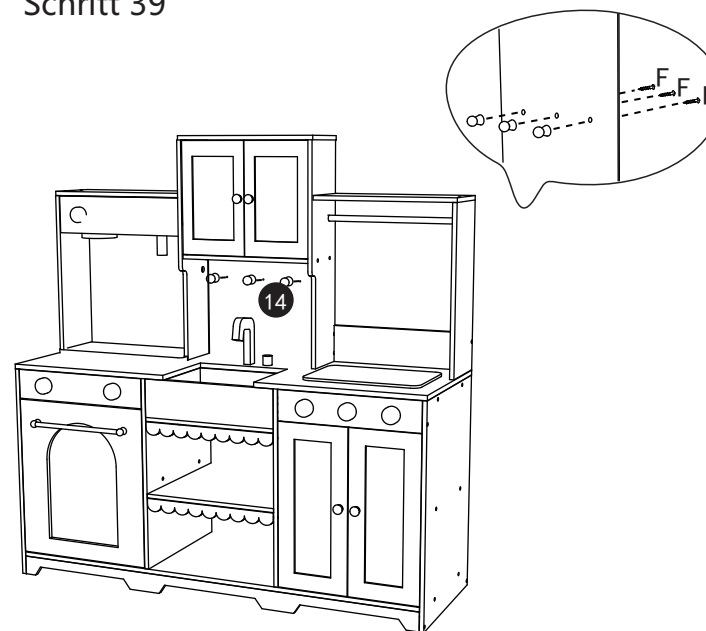

C	 M4x20 8	

### Schritt 39

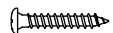

F	 M3x14 3	

Anti-backoff Set /Kippschutz /Kit Anti-basculement  
 /Juego Antivuelco /Set Antiribaltamento  
 /Zestaw zapobiegający wywróceniu /Anti-kantelset

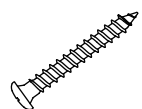

x2



x2



x2



x2

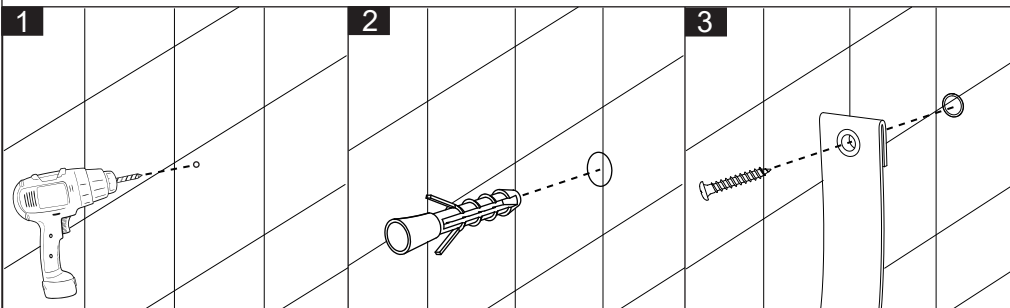
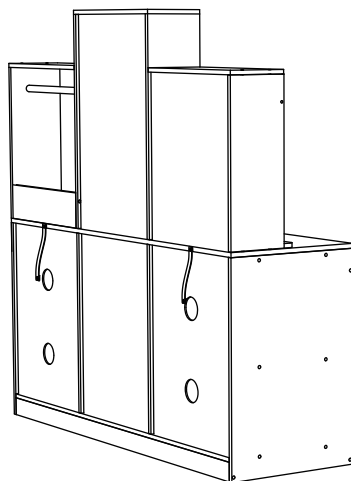
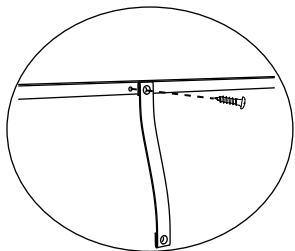

DE  
**Warnung:** Die maximale Belastbarkeit dieses Möbels beträgt: 10 kg, bitte nicht überlasten!  
 EN  
**Warning:** The maximum load-bearing capacity of this furniture is: 10 kg, please do not overload!  
 FR  
**Avertissement :** La capacité de charge maximale de ce meuble est de : 10 kg, merci de ne pas surcharger !  
 IT  
**Attenzione:** la capacità di carico massima di questo mobile è: 10 kg, non sovraccaricare!  
 ES  
**Advertencia:** La capacidad máxima de carga de este mueble es: 10 kg, ¡no lo sobrecargue!