

Installationsanleitung Installation Instruction Instruction d'installation

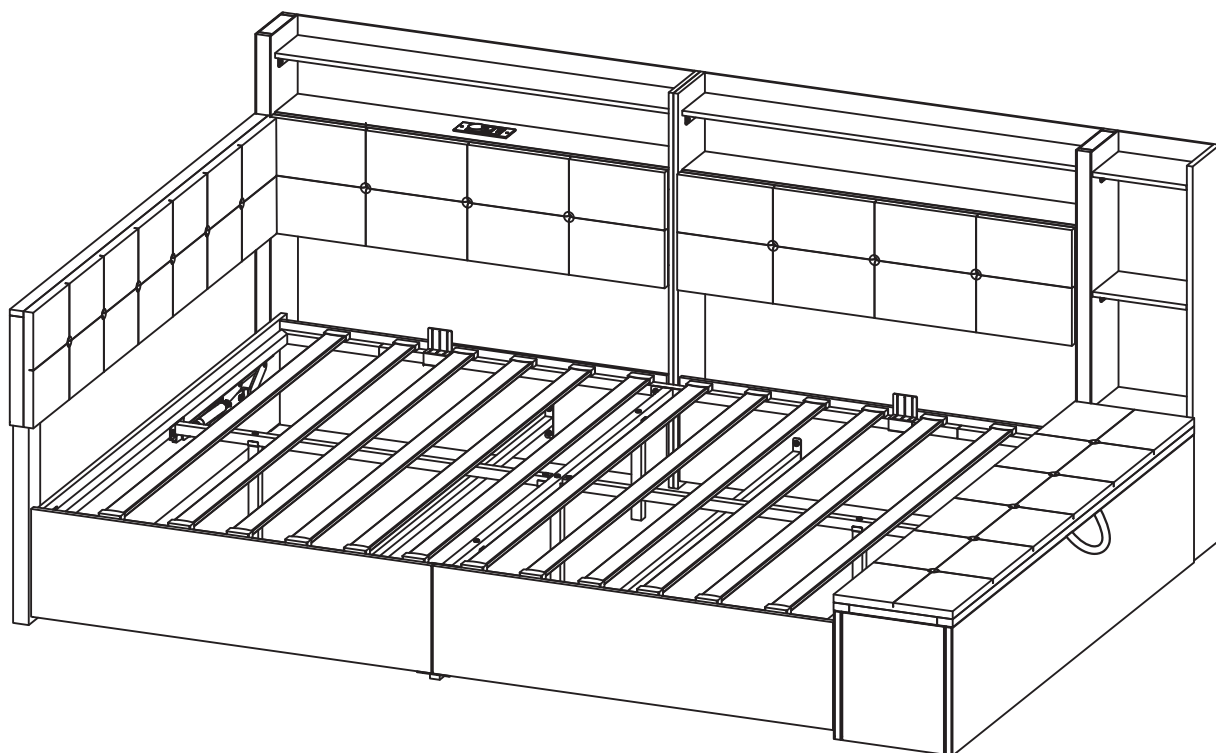

Unser Produkt wird Ihnen in 3 Paketen geliefert. Die Lieferzeiten dieser 3 Pakete können abweichen, bitte haben Sie etwas Geduld und vielen Dank für Ihr Verständnis.

Our product will be delivered to you in 3 packages. The delivery times of these 3 packages may differ, please be patient and thank you for your understanding.

Notre produit vous sera livré en 3 colis. Les délais de livraison de ces 3 colis peuvent différer, soyez patient et merci pour votre compréhension.

N636P459790
N636P459792

N636P459791

English

IMPORTANT ! KEEP FOR FUTURE REFERENCE : READ CAREFULLY

- To be assembled by an adult. Assembly must be checked by an adult before use
- **WARNING!** Keep all screws, small parts and plastic bags out of the reach of children
- Properly identify all parts before assembling
- Never use your item if any of its parts are broken or missing
- Should any problems arise, please contact our After Sales Service
- Manufacturer's instructions shall be followed at all times
- Care: Clean with a soft, dry cloth. In case of larger stains, carefully rub with a slightly damp, non- abrasive sponge
- Avoid the risk of fire by not placing furniture near sources of ignition or hot items
- Do not jump on the bed

Deutsch

WICHTIG! ZUM SPÄTEREN NACHSCHLAGEN AUFBEWAHREN: SORGFÄLTIG LESEN

- Muss von einem Erwachsenen zusammengebaut werden. Der Zusammenbau muss vor dem Gebrauch von einem Erwachsenen überprüft werden
- **WARNUNG!** Bewahren Sie alle Schrauben, Kleinteile und Plastikbeutel außerhalb der Reichweite von Kindern auf
- Kennzeichnen Sie vor dem Zusammenbau alle Teile richtig
- Benutzen Sie Ihren Artikel niemals, wenn Teile gebrochen sind oder fehlen
- Sollten Probleme auftreten, wenden Sie sich bitte an unseren Kundendienst
- Die Anweisungen des Herstellers sind stets zu befolgen
- Pflege: Mit einem weichen, trockenen Tuch reinigen. Bei größeren Flecken vorsichtig mit einem leicht feuchten, nicht scheuernden Schwamm abreiben. nicht scheuernden Schwamm
- Vermeiden Sie die Gefahr eines Brandes, indem Sie die Möbel nicht in der Nähe von Zündquellen oder heißen Gegenständen aufstellen
- Nicht auf das Bett springen

Français

IMPORTANT! CONSERVER POUR RÉFÉRENCE ULTÉRIEURE: LIRE ATTENTIVEMENT

- Le montage doit être effectué par un adulte. Le montage doit être vérifié par un adulte avant utilisation
 - **ATTENTION!** Tenir les vis, les petites pièces et les sachets en plastique hors de portée des enfants
 - Identifiez correctement toutes les pièces avant de les assembler
 - N'utilisez jamais votre article si l'une de ses pièces est cassée ou manquante
 - En cas de problème, veuillez contacter notre service après-vente
 - Les instructions du fabricant doivent être respectées à tout moment
 - Entretien: nettoyer avec un chiffon doux et sec. En cas de taches plus importantes, frotter soigneusement avec une éponge non abrasive légèrement humide. légèrement humide et non abrasive
 - Évitez les risques d'incendie en ne plaçant pas les meubles à proximité de sources d'inflammation ou d'objets chauds
- Ne pas sauter sur le lit

- Deve essere assemblato da un adulto. L'assemblaggio deve essere controllato da un adulto prima dell'uso
- **ATTENZIONE!** Tenere tutte le viti, le piccole parti e i sacchetti di plastica fuori dalla portata dei bambini
- Identificare correttamente tutte le parti prima dell'assemblaggio
- Non utilizzare mai l'articolo se alcune parti sono rotte o mancanti
- In caso di problemi, si prega di contattare il nostro Servizio Post Vendita
- Le istruzioni del produttore devono essere sempre seguite
- Cura: Pulire con un panno morbido e asciutto. In caso di macchie più estese, strofinare accuratamente con una spugna leggermente umida e nonspugna leggermente umida e non abrasiva
- Evitare il rischio di incendio, non collocando i mobili vicino a fonti di accensione o a oggetti caldi
- Non saltare sul letto

- Debe ser montado por un adulto. El montaje debe ser comprobado por un adulto antes del uso
- **ADVERTENCIA** Mantenga todos los tornillos, piezas pequeñas y bolsas de plástico fuera del alcance de los niños
- Identifique correctamente todas las piezas antes de montarlas
- Nunca utilice su artículo si alguna de sus piezas está rota o falta
- Si surge algún problema, póngase en contacto con nuestro Servicio Postventa
- Las instrucciones del fabricante deben seguirse en todo momento
- Cuidado: Limpiar con un paño suave y seco. En caso de manchas más grandes, frote cuidadosamente con una esponja no abrasiva ligeramente humedecida
- Evite el riesgo de incendio no colocando los muebles cerca de fuentes de ignición u objetos calientes
- No saltar sobre la cama

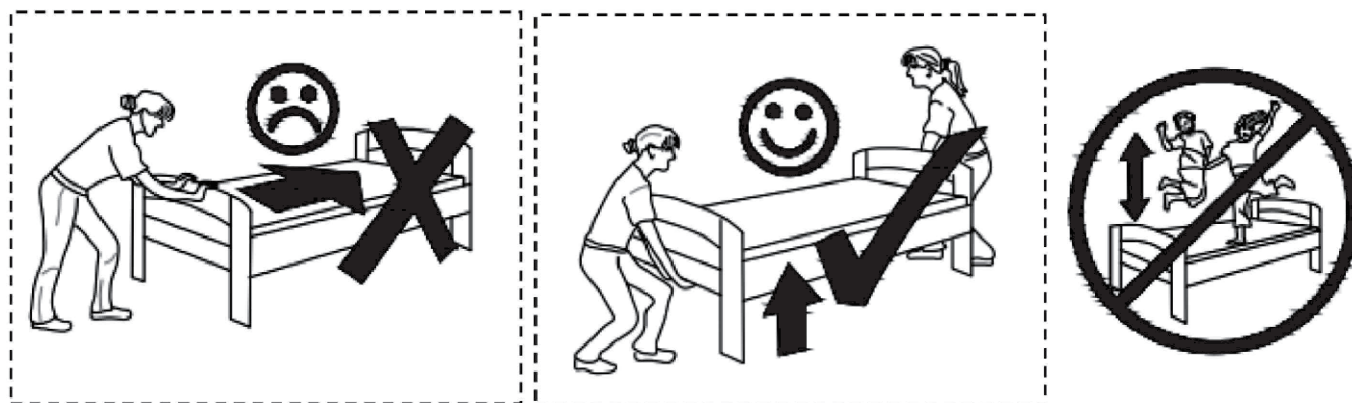









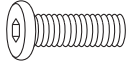





Vor dem Einbau die Schrauben in die Löcher stecken und festziehen, aber nicht bis 100%, 70% bis 80% anziehen reicht aus. Schließlich, nachdem alle Schrauben installiert sind, ziehen Sie alle Schrauben auf 100%. Wenn Sie auf diese Probleme stoßen, wie z. B. Fehlausrichtung der Löcher oder Unfähigkeit, bestimmte Teile zu installieren, überprüfen Sie bitte, ob die Schrauben korrekt verwendet werden und passen Sie die Dichtigkeit der Schrauben an.

Before installation, insert the screws into the holes and tighten them, but do not tighten them to 100%, 70% to 80% is sufficient. Finally, after all screws are installed, tighten all screws to 100%. If you encounter these issues, such as if the holes cannot be aligned or some parts cannot be installed, please check if the screws are used correctly and adjust the tightness of the screws.

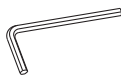
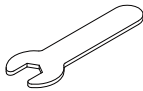
Insérer la vis dans le trou avant la fin de l'assemblage, serrer la vis, mais ne pas serrer à 100%, 70% ~ 80% est correct. Enfin, une fois que toutes les vis sont bien serrées, toutes les vis sont serrées à 100%. Si vous rencontrez ces problèmes, par exemple si les trous ne sont pas alignés ou si certaines pièces ne peuvent pas être montées, vérifiez que les vis sont utilisées correctement et Ajustez leur serrage.

Hardware List For N636P459791

 M8x12mm A x 16	 M8x18mm B x 107	 M6x10mm C x 32	 M6x15mm D x 10	 Ø5x35mm E x 22	 M8x30mm F x 10
 M8x40mm G x 17	 Ø4x10mm H x 2	 M8 nut I x 10	 M5 J x 1	 M4 K x 1	 M3 L x 1
 M x 1					

 M6x10mm C x 32	 M6x15mm D x 10	 Ø5x35mm D x 22
--	--	--

DE:Bitte beachten Sie, dass die Formen der Schrauben C und D und E ähnlich sind. Bitte installieren Sie entsprechend der Anleitung und unterscheiden Sie sie!

UK>Please note that the shapes of screws C and D and E are similar. Please install according to the instructions and distinguish them!

FR:Notez que les vis C et D et E ont des formes similaires. Veuillez les installer en suivant les instructions pour les séparer!

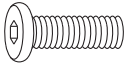
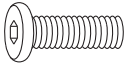
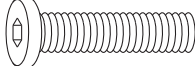
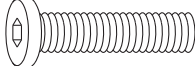
 M8x12mm A x 16	 M8x18mm B x 107	 M8x30mm F x 10	 M8x40mm G x 17
--	---	---	--

DE:Bitte beachten Sie, dass die Formen der Schrauben A und B und F und G ähnlich sind. Bitte installieren Sie entsprechend der Anleitung und unterscheiden Sie sie!

UK>Please note that the shapes of screws A and B and F and G are similar. Please install according to the instructions and distinguish them!

FR:Notez que les vis A et B et F et G ont des formes similaires. Veuillez les installer en suivant les instructions pour les séparer!

Part list

SKU:N636P459790/N636P459791
N636P459792

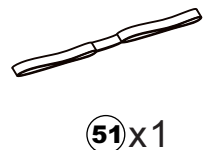
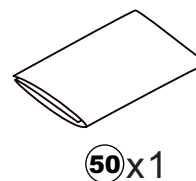
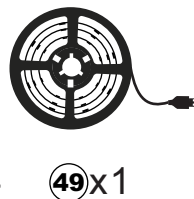
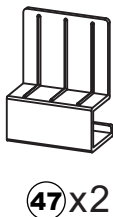
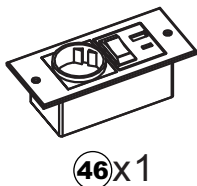
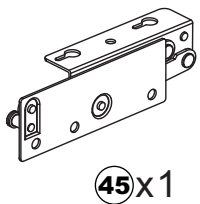
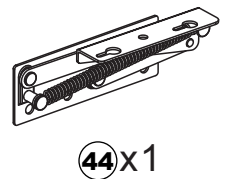
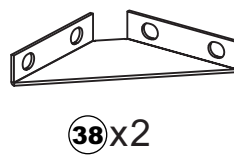
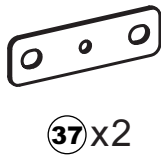
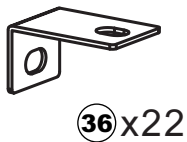
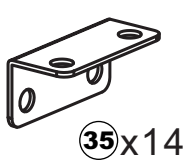
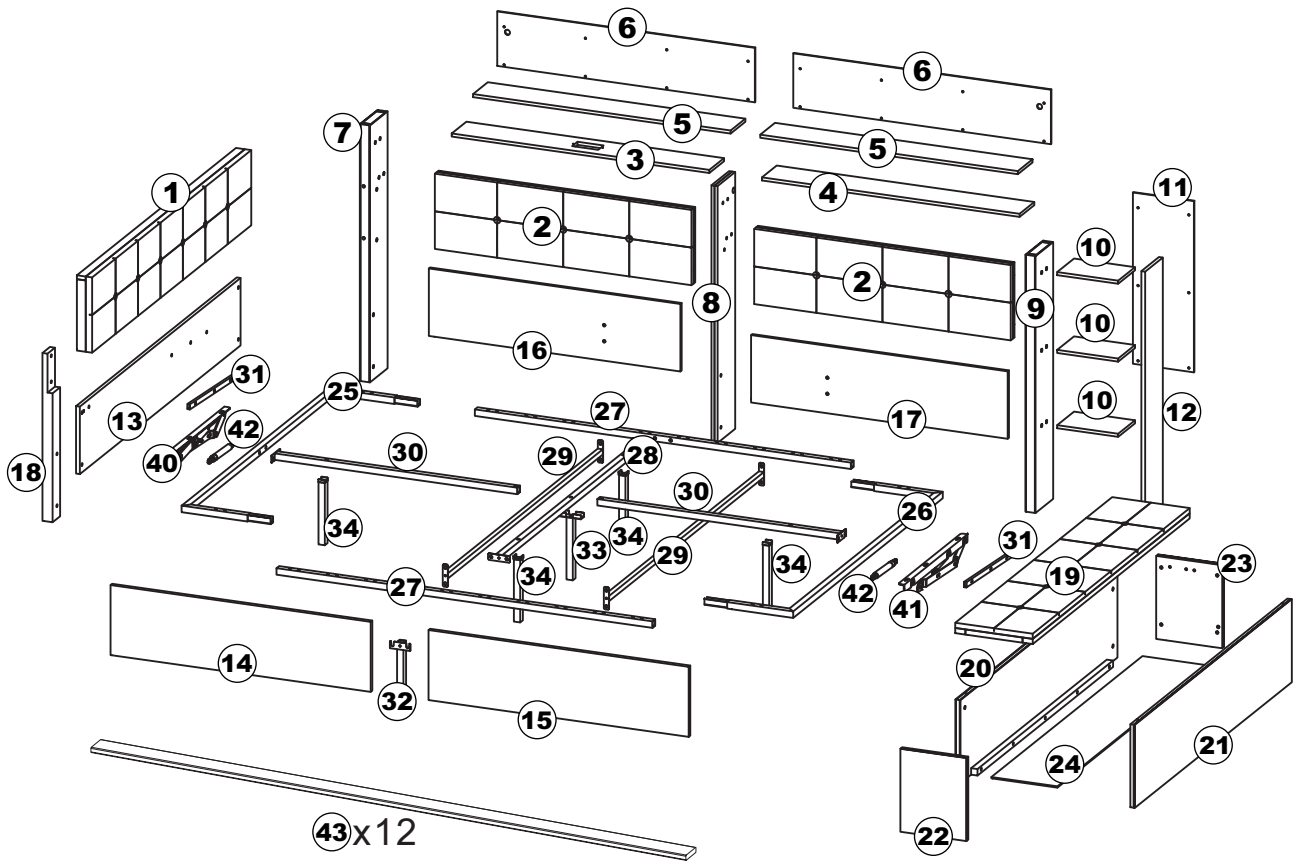

SKU:N636P459790

PART LIST (N636P459790) / STÜCKLISTE (N636P459791)
(N636P459792)

① x1

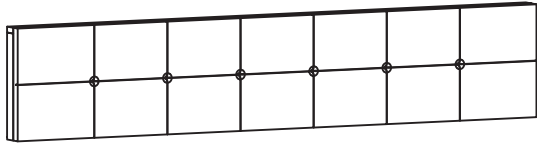

⑥ x2

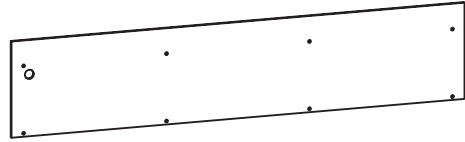

⑩ x3

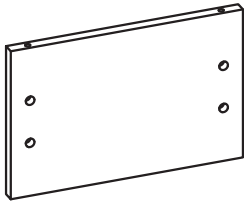

⑪ x1

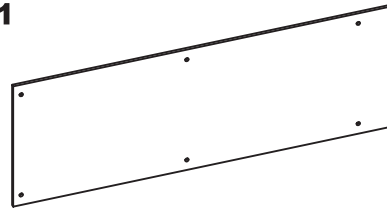

⑬ x1

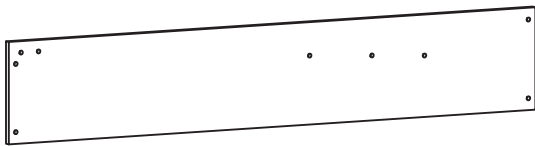

⑲ x1

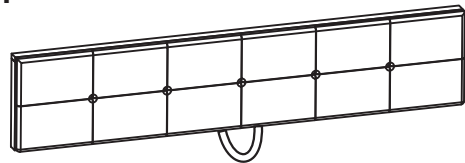

⑳ x1

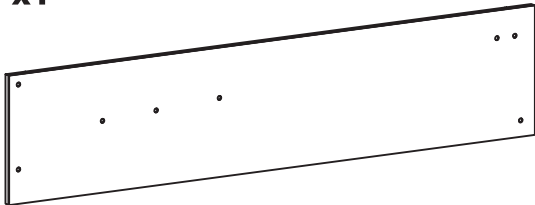

㉑ x1

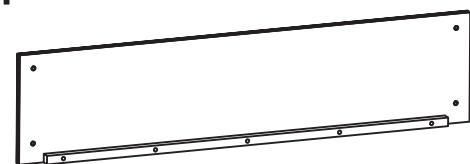

㉒ x1

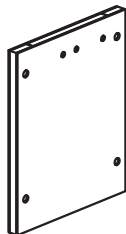

㉓ x1

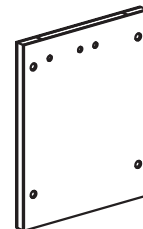



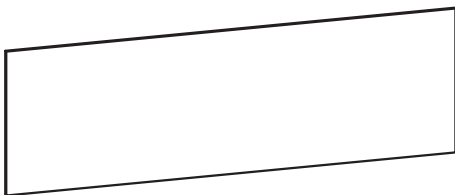

㉔ x1

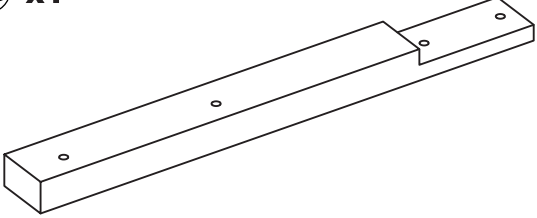
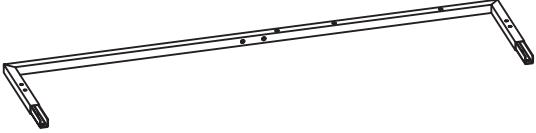
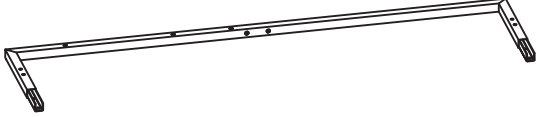
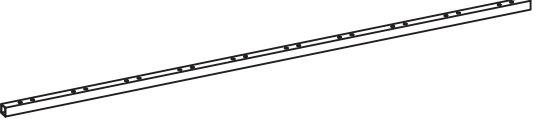
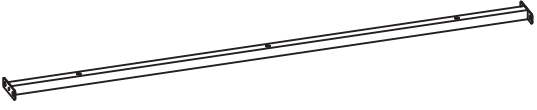

SKU:N636P459791

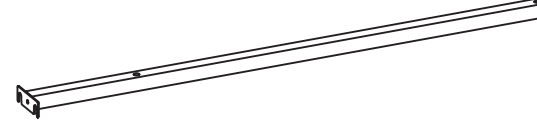
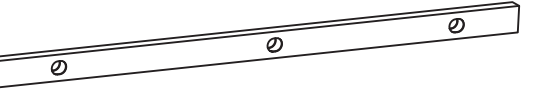
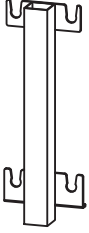
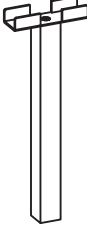
PART LIST (N636P459790) / STÜCKLISTE (N636P459791)
(N636P459792)

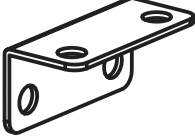
<p>18 x1</p> 	<p>25 x1</p> 
<p>26 x1</p> 	<p>27 x2</p> 
<p>28 x1</p> 	<p>29 x2</p> 
<p>30 x2</p> 	<p>31 x2</p> 
<p>32 x1</p> 	<p>33 x1</p> 
<p>34 x4</p> 	<p>35 x14</p> 

36 x22

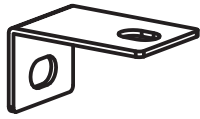

37 x2

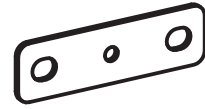

38 x2



39 x9



40 x1

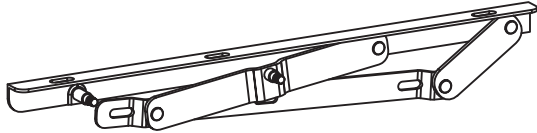

41 x1

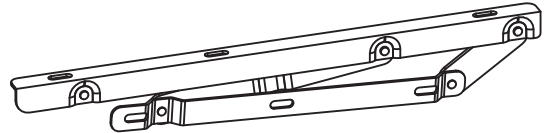

42 x2

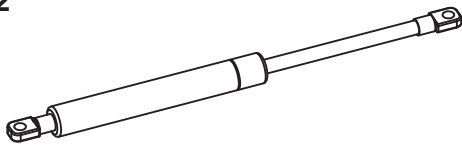

43 x12



44 x1

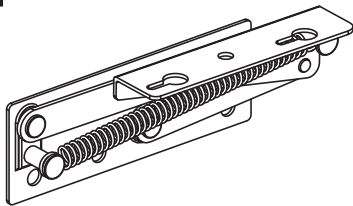

45 x1

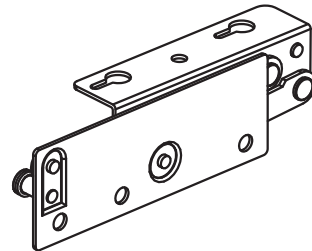

46 x1

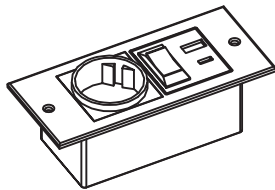

47 x2

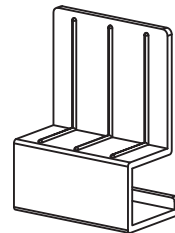

48 x24

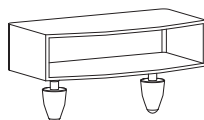

49 x1

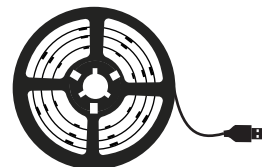

50 x1

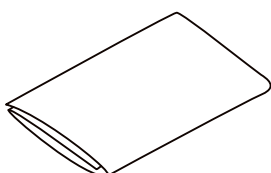

51 x1

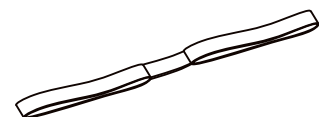

SKU:N636P459792

PART LIST (N636P459790) / STÜCKLISTE (N636P459791)
(N636P459792)

② x2

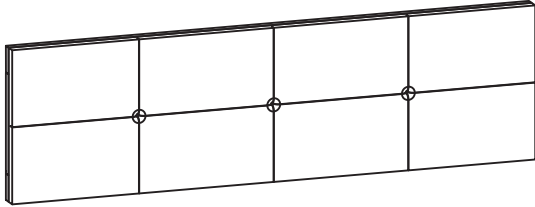

③ x1

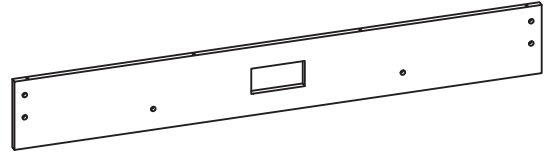

④ x1

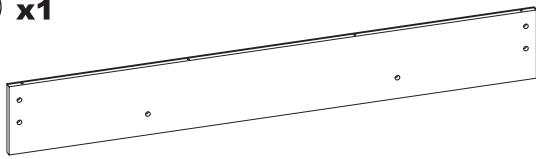

⑤ x2

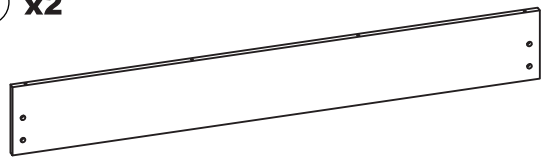

⑦ x1

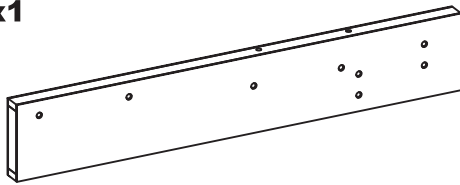

⑧ x1

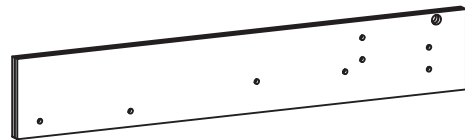

⑨ x1

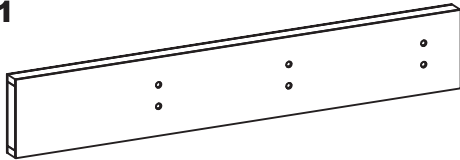

⑫ x1

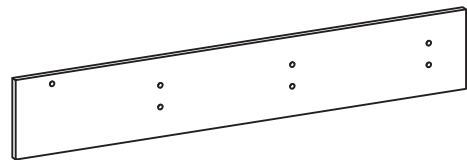

⑭ x1

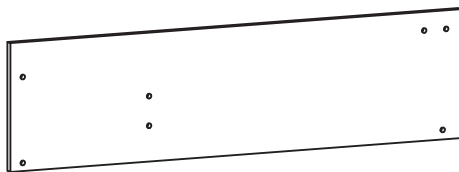

⑮ x1



⑯ x1



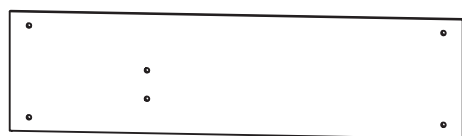

⑰ x1

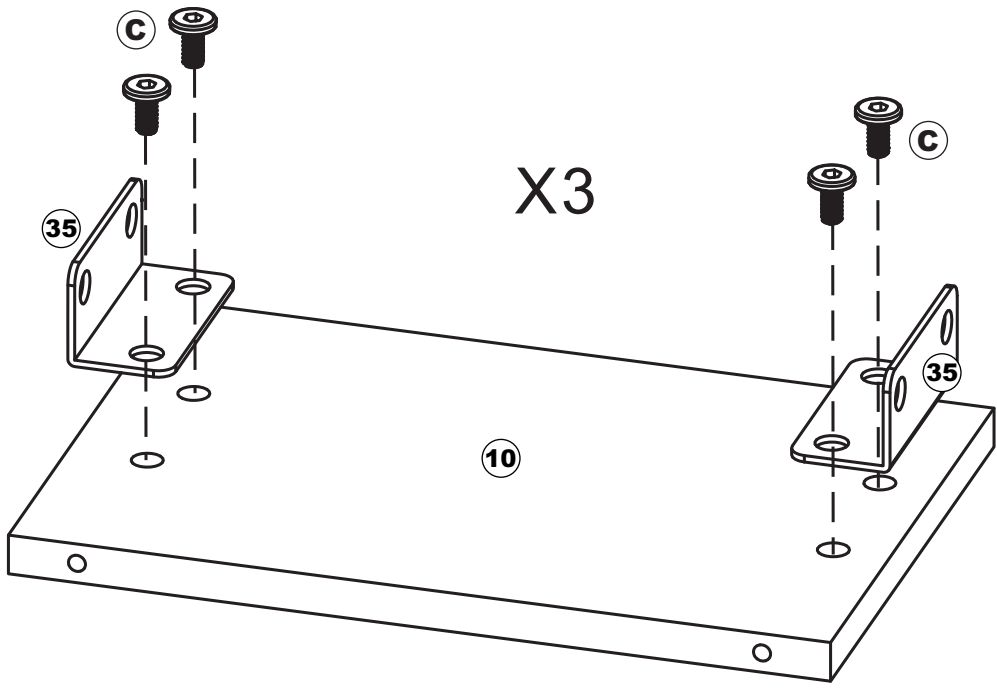

Step 1

(C)  **x12**
M6 x 10mm



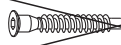

	M6x10mm
	M6x15mm
	Ø 5x35mm

Step 2

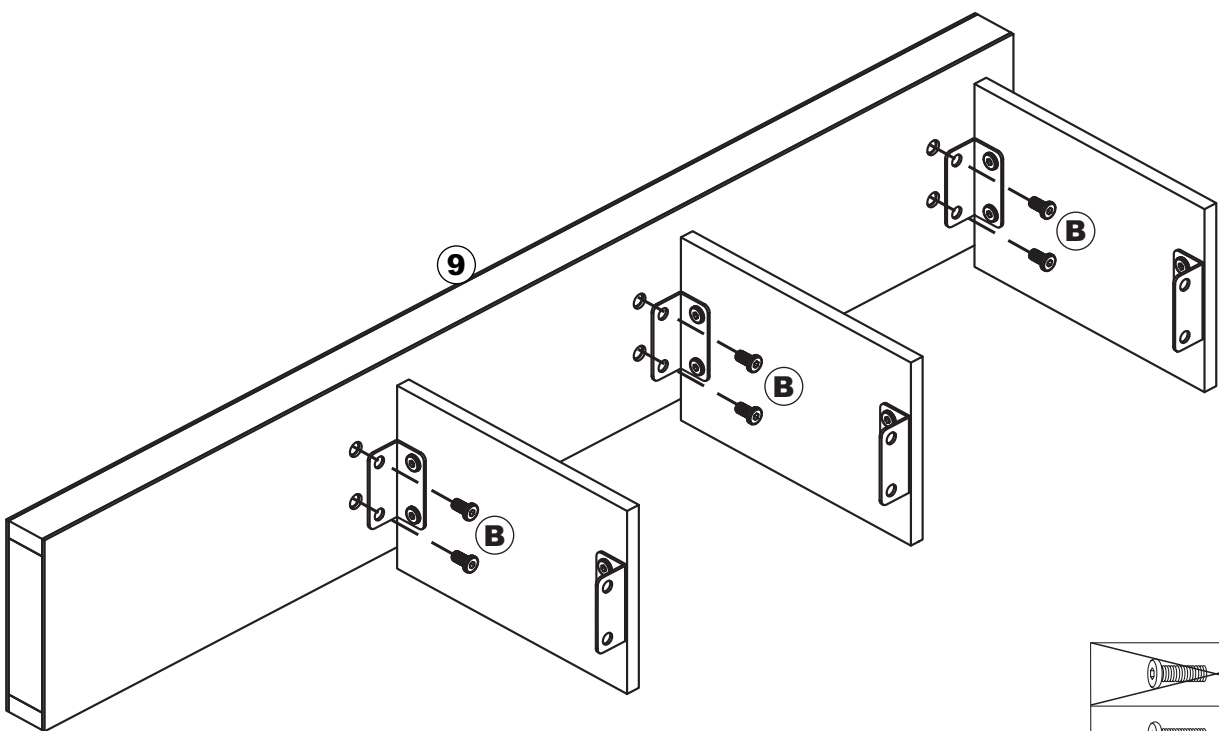
(B)  **x6**
M8 x 18mm



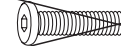
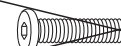

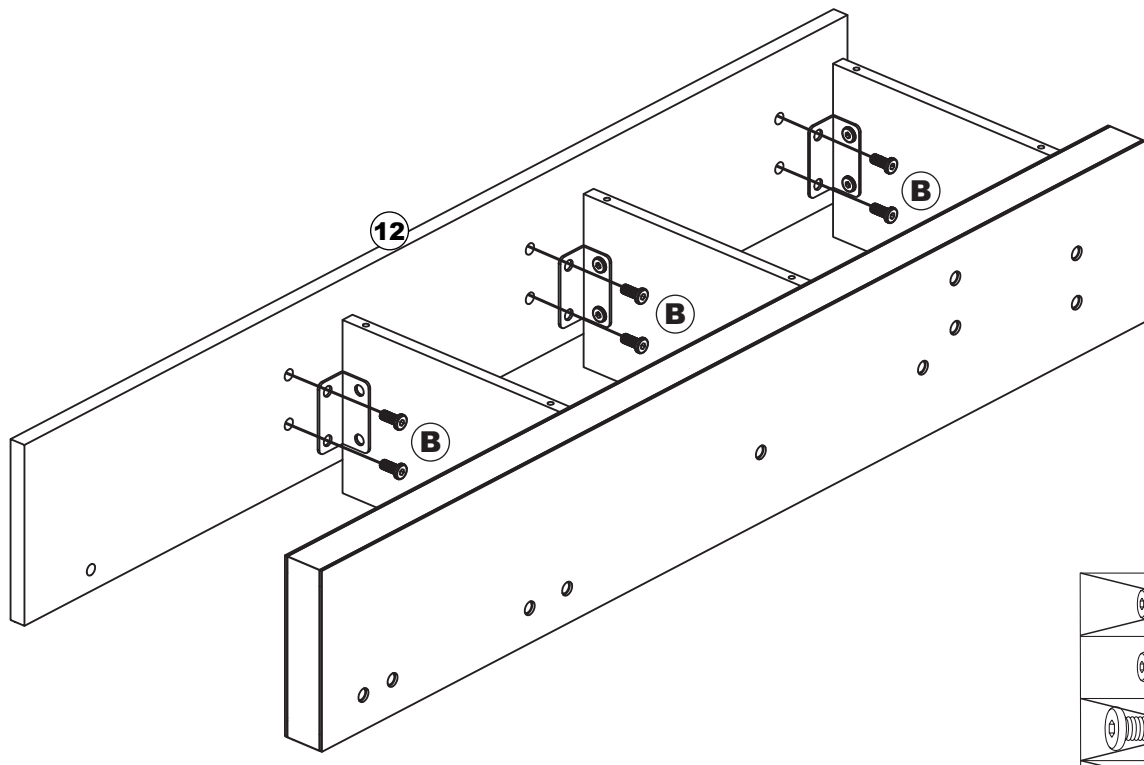

	M8x12mm
	M8x18mm
	M8x30mm
	M8x40mm

Step 3

B  **x6**
M8 x 18mm





	M8x12mm
	M8x18mm
	M8x30mm
	M8x40mm

Step 4

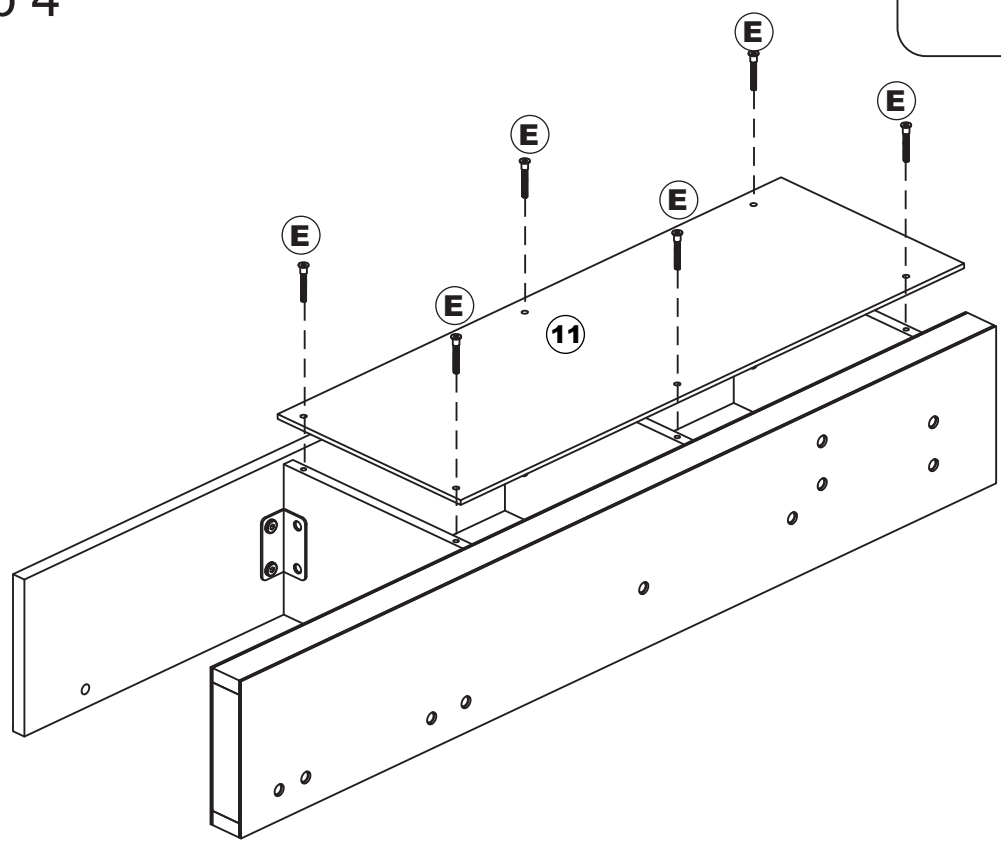
E  **x6**
Ø5X35mm



	M6x10mm
	M6x15mm
	Ø5x35mm

12

Step 5

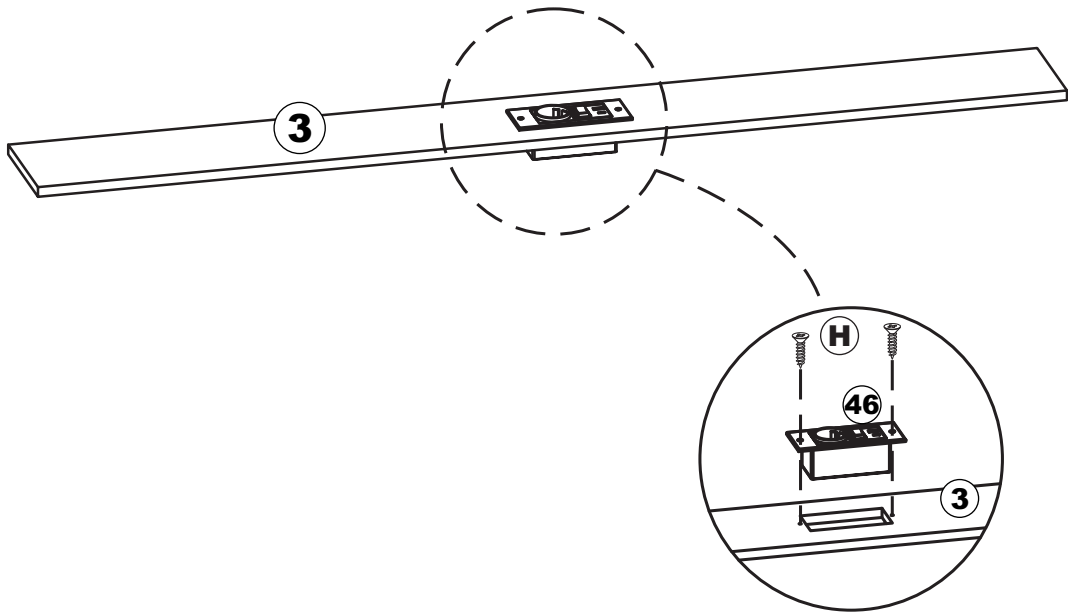

H  **x2**
Ø4 x 10mm

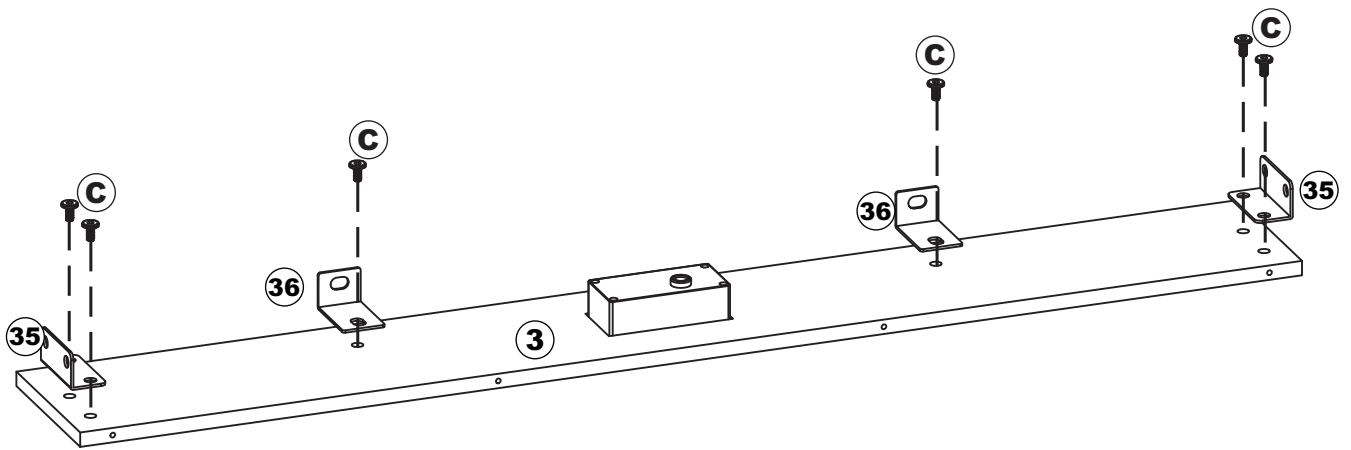

Step 6

C  **x6**
M6 x 10mm



	M6x10mm
	M6x15mm
	Ø5x35mm

Step 7

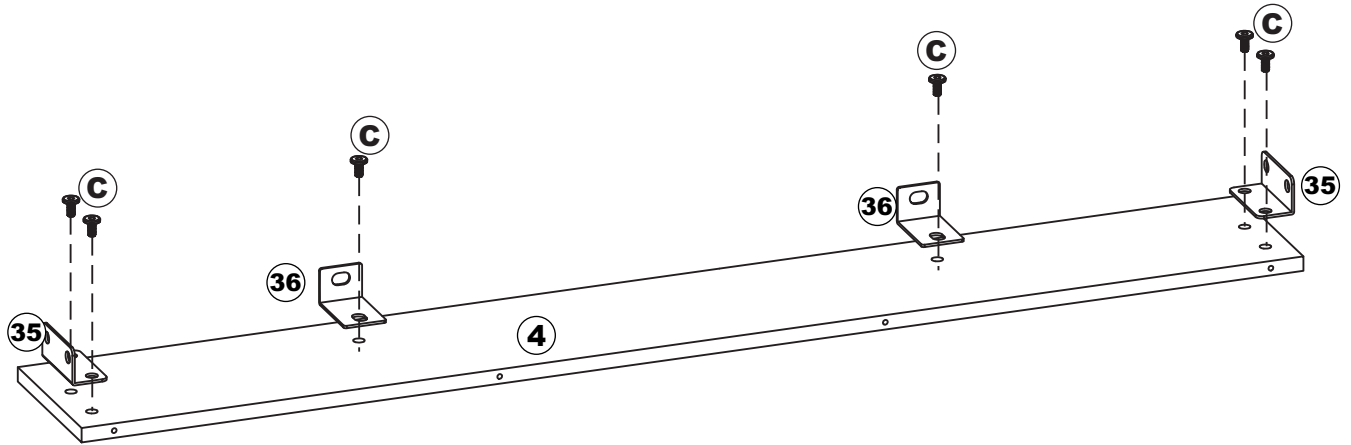

C  **x6**
M6 x10mm

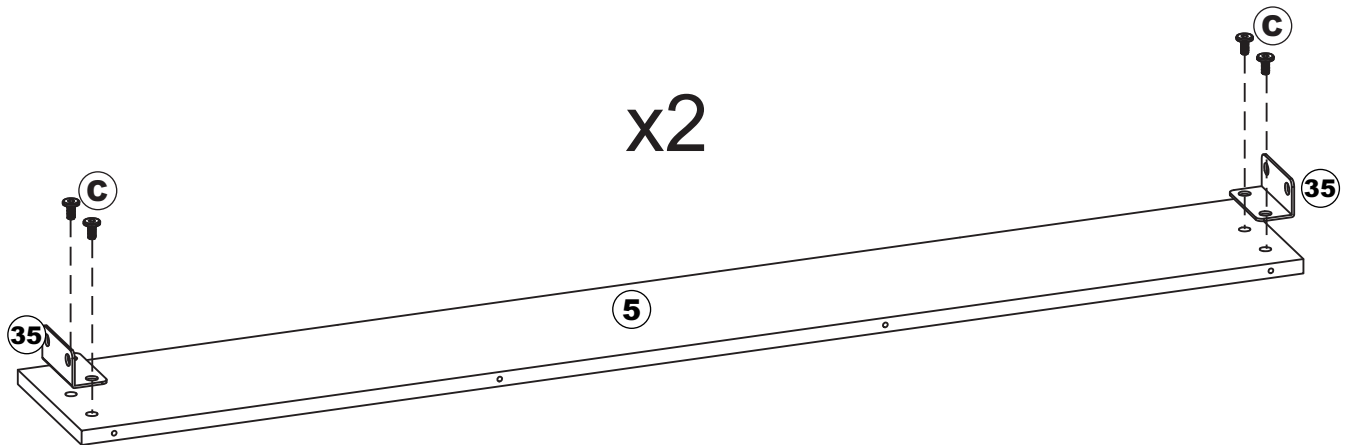

Step 8

C  **x8**
M6 x10mm





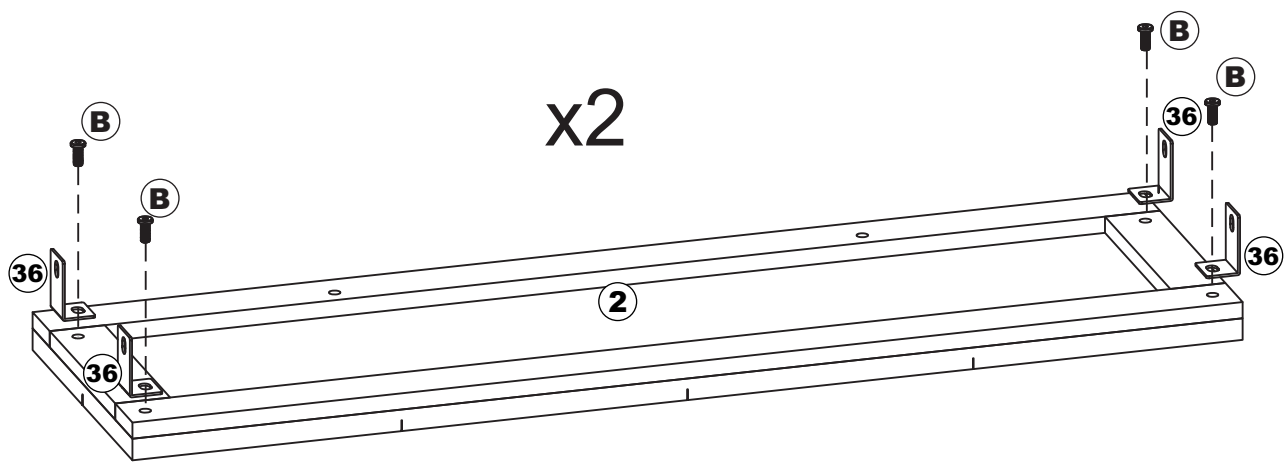

	M6x10mm
	M6x15mm
	Ø5x35mm

Step 9

B  **x8**
M8 x 18mm







	M8x12mm
	M8x18mm
	M8x30mm
	M8x40mm

Step 10

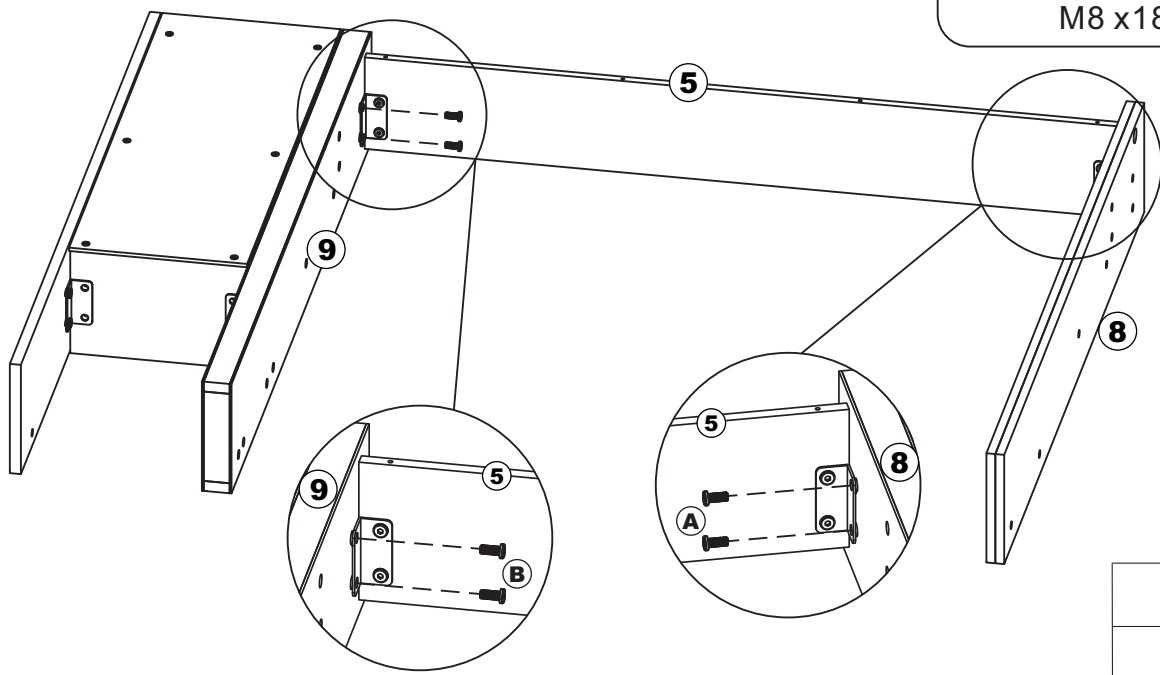

A  **x2**
M8 x 12mm

B  **x2**
M8 x 18mm





	M8x12mm
	M8x18mm
	M8x30mm
	M8x40mm

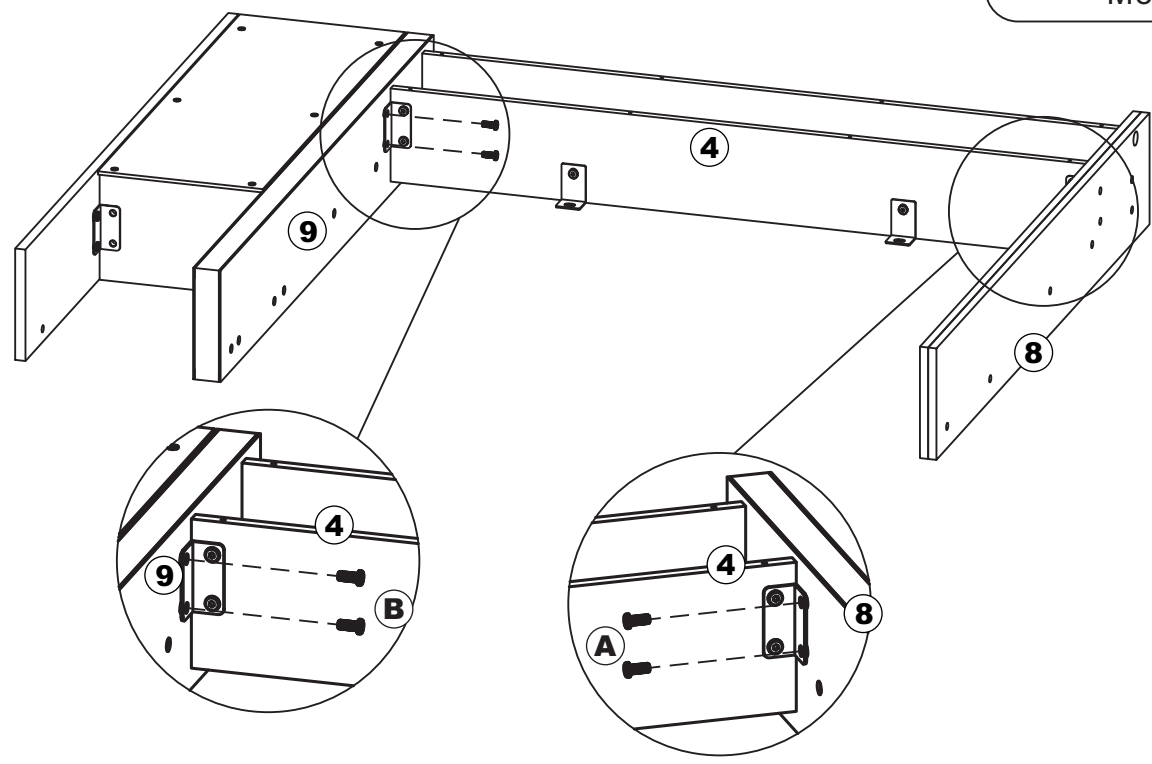

Step 11

- A**  **x2**
M8 x 12mm
- B**  **x2**
M8 x 18mm

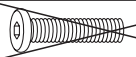
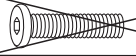



	M8x12mm
	M8x18mm
	M8x30mm
	M8x40mm

Step 12

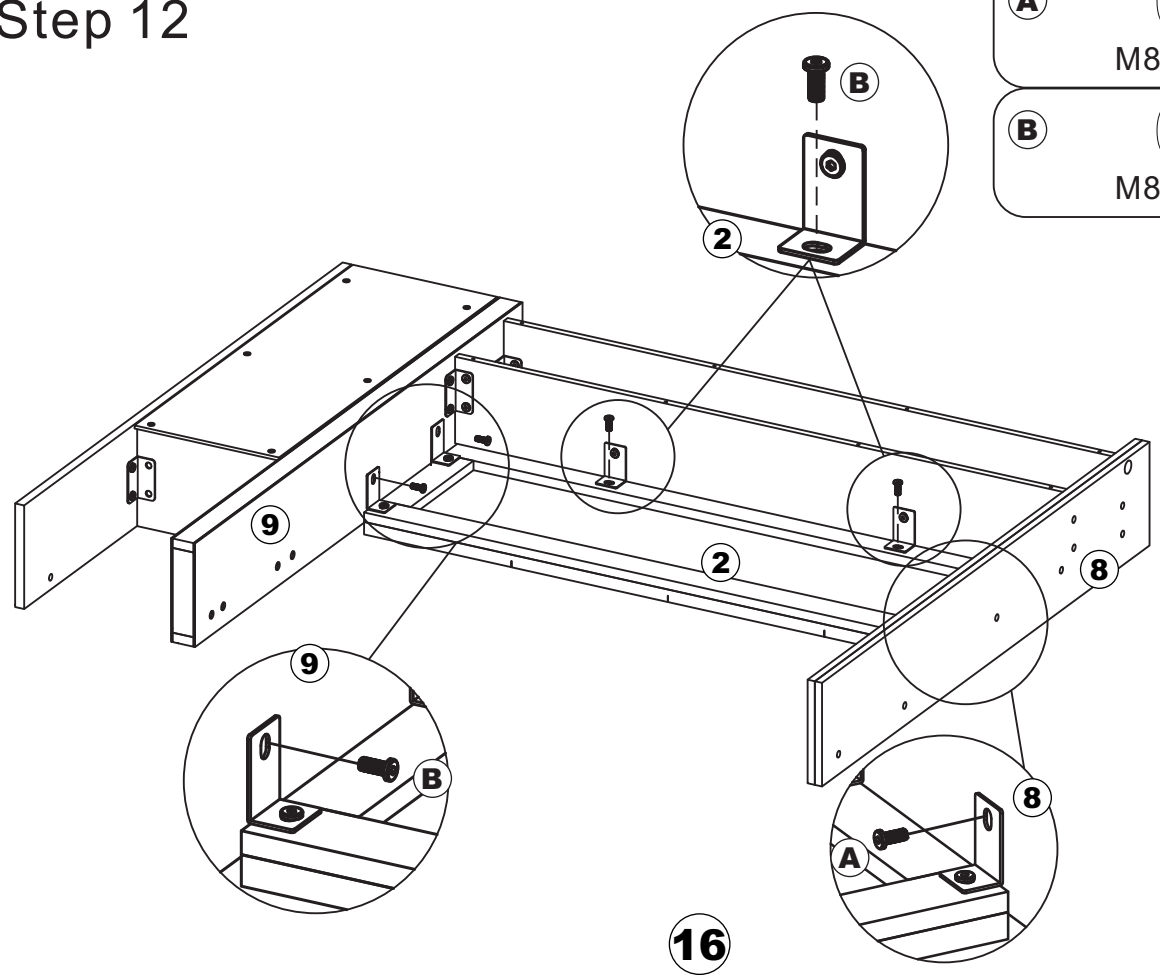
- A**  **x2**
M8 x 12mm
- B**  **x4**
M8 x 18mm



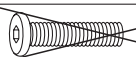
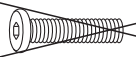



	M8x12mm
	M8x18mm
	M8x30mm
	M8x40mm

Step 13

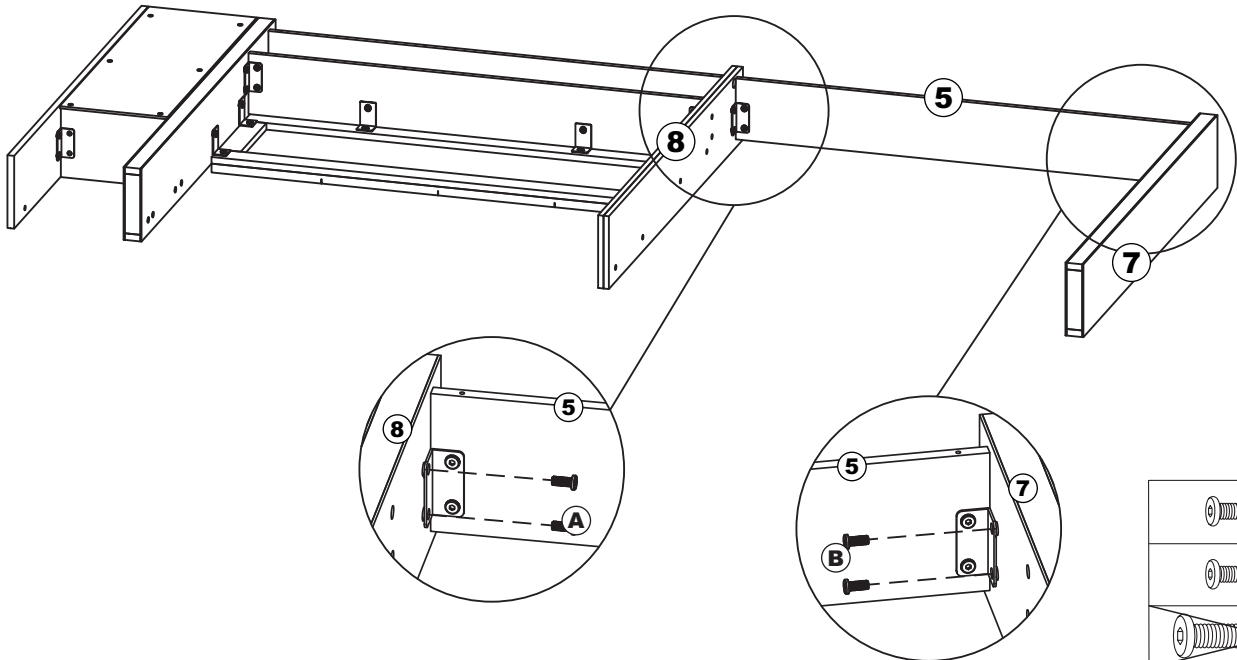
A  **x2**
M8 x 12mm

B  **x2**
M8 x 18mm







	M8x12mm
	M8x18mm
	M8x30mm
	M8x40mm

Step 14

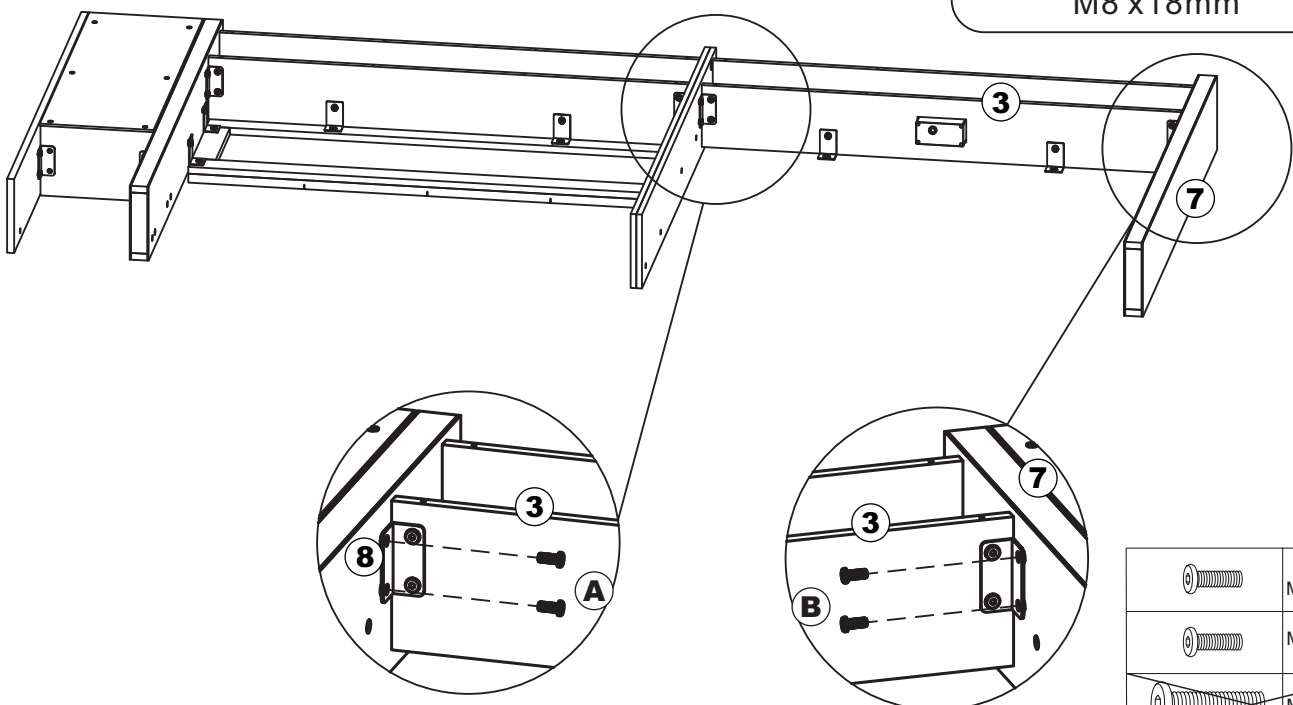
A  **x2**
M8 x 12mm

B  **x2**
M8 x 18mm







	M8x12mm
	M8x18mm
	M8x30mm
	M8x40mm

Step 15

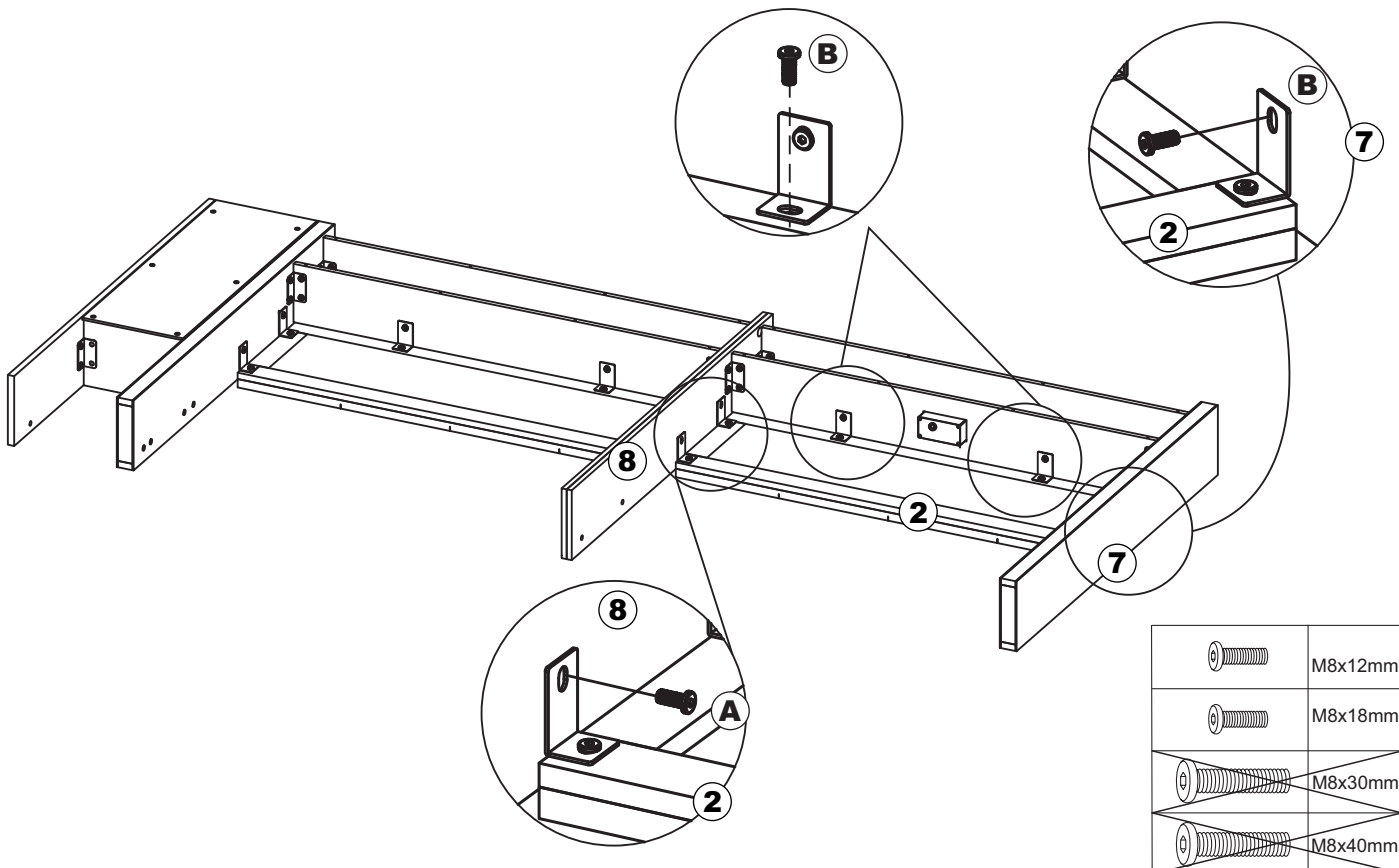
A  **x2**
M8 x 12mm

B  **x4**
M8 x 18mm





	M8x12mm
	M8x18mm
	M8x30mm
	M8x40mm

Step 16

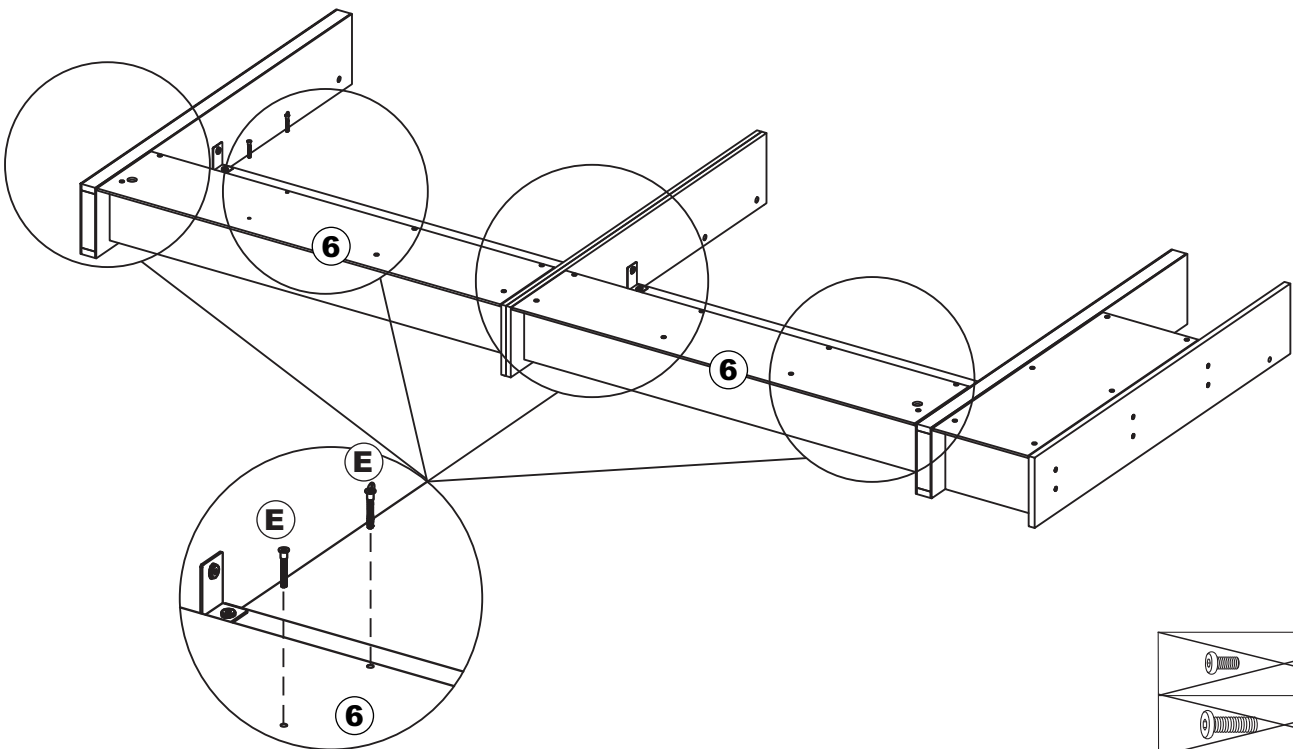
E  **x16**
Ø5X35mm





	M6x10mm
	M6x15mm
	Ø5x35mm

Step 17

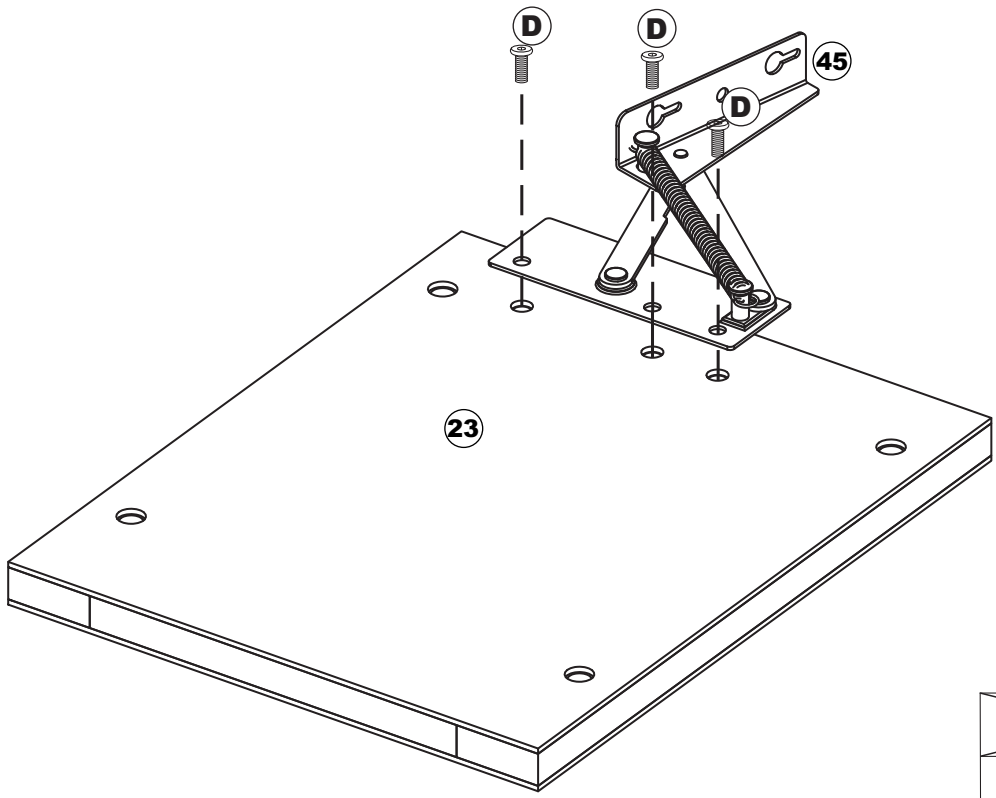
D  **x3**
M6 x 15mm



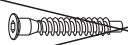

	M6x10mm
	M6x15mm
	Ø5x38mm

Step 18

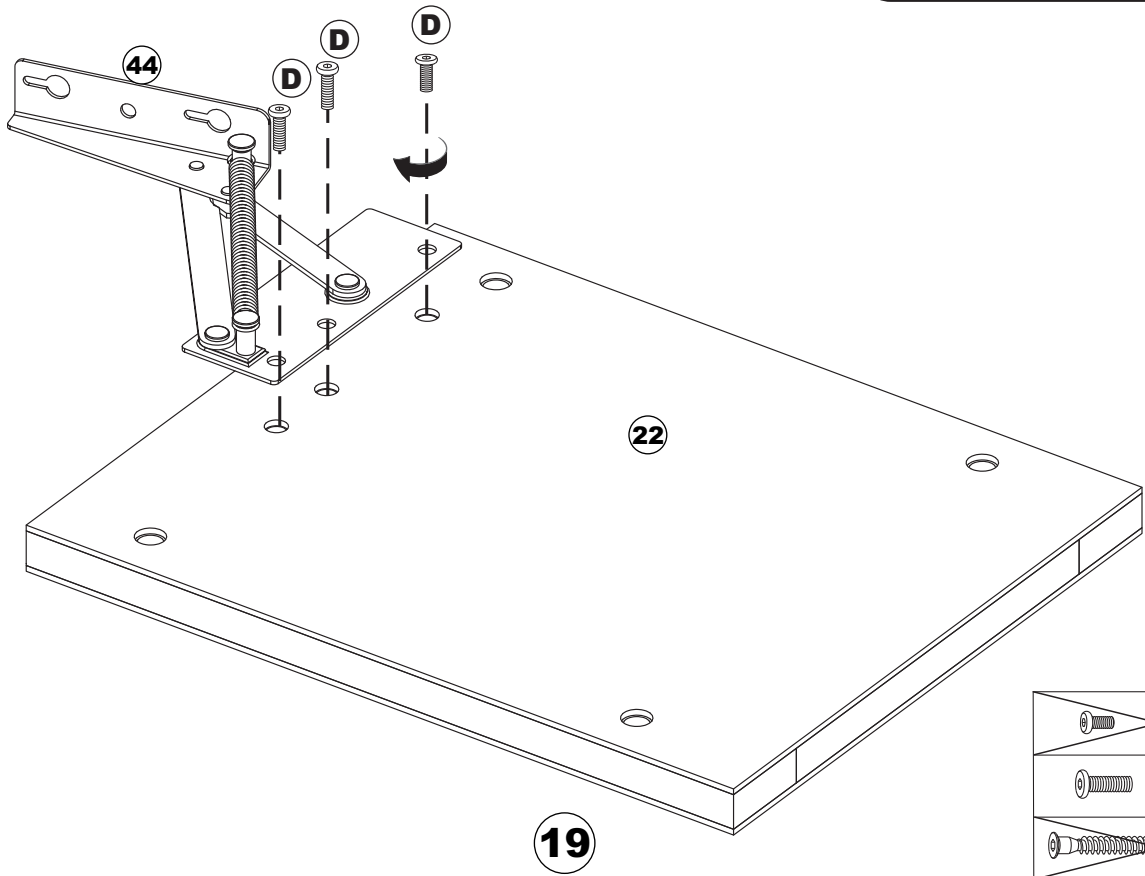
D  **x3**
M6 x 15mm



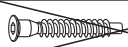

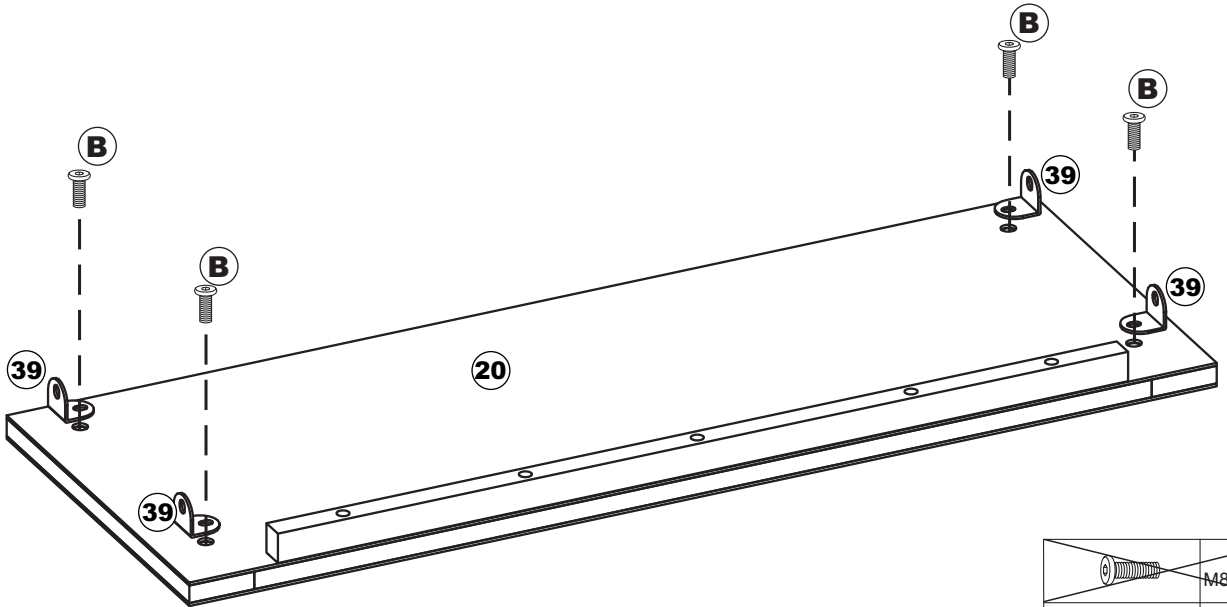

	M6x10mm
	M6x15mm
	Ø5x35mm

Step 19

B  **x4**
M8 x 18mm





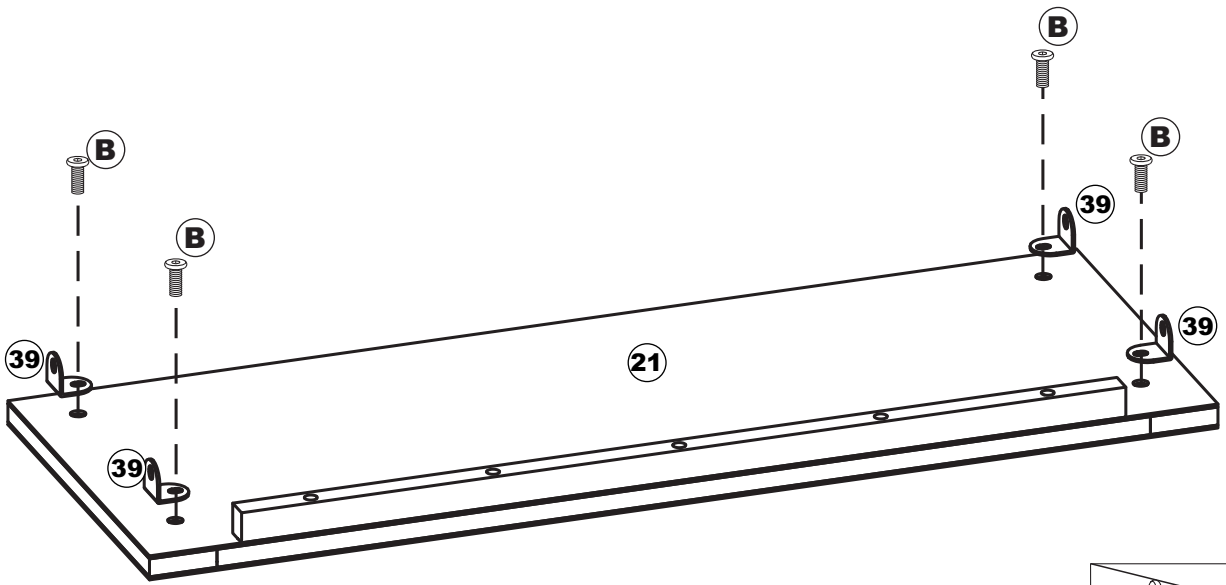

	M8x12mm
	M8x18mm
	M8x30mm
	M8x40mm

Step 20

B  **x4**
M8 x 18mm







	M8x12mm
	M8x18mm
	M8x30mm
	M8x40mm

20

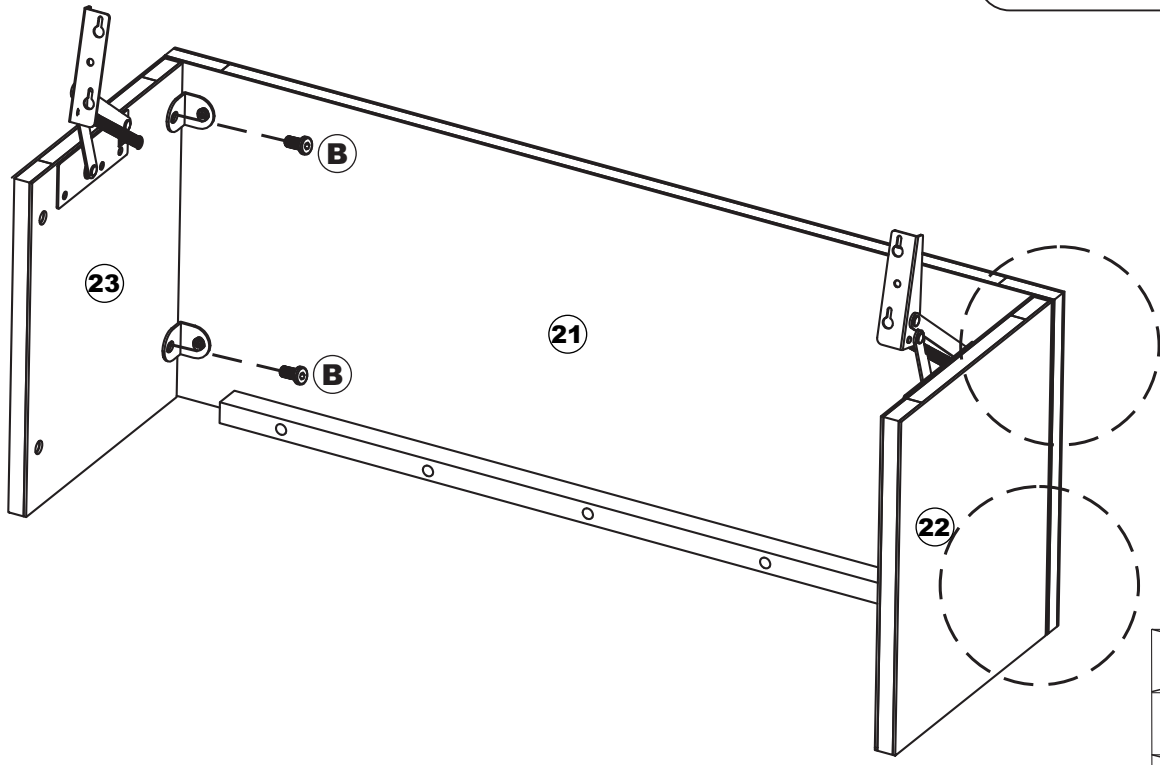
Step 21

B  **x4**
M8 x 18mm





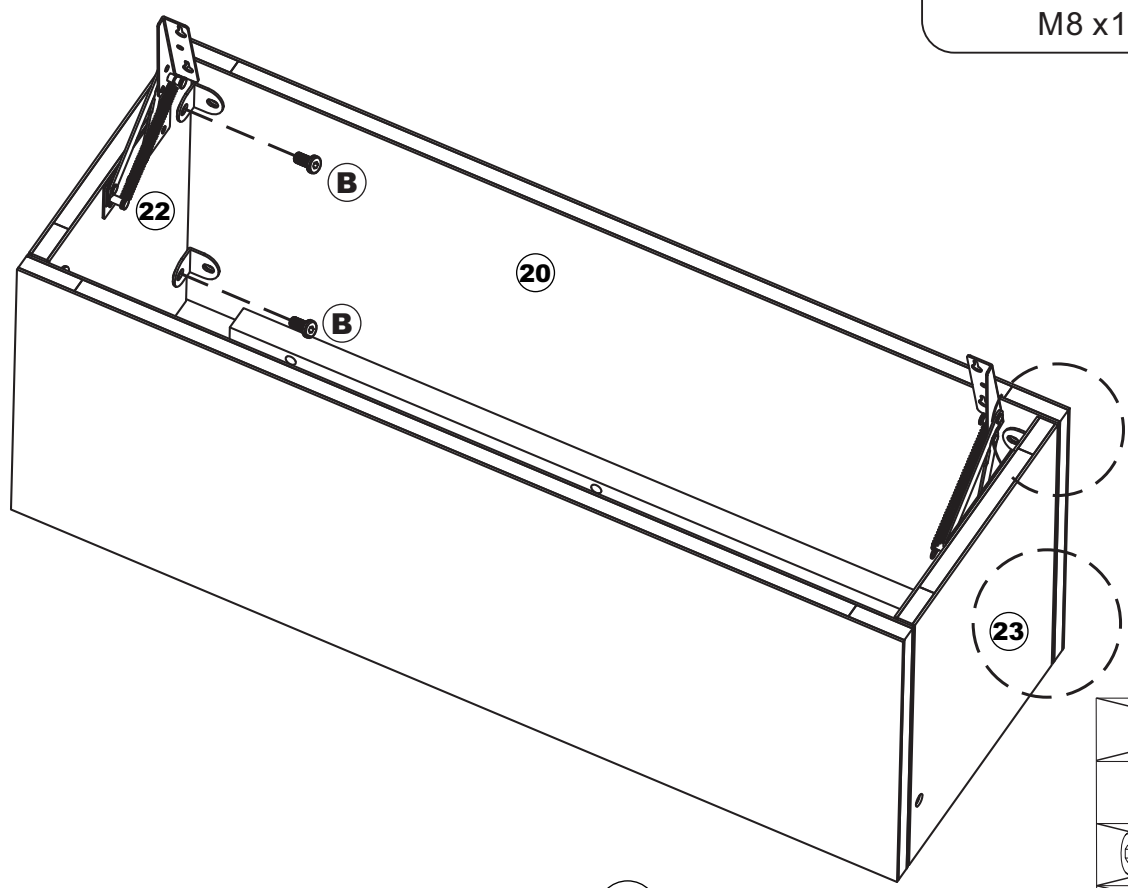

	M8x12mm
	M8x18mm
	M8x30mm
	M8x40mm

Step 22

B  **x4**
M8 x 18mm





	M8x12mm
	M8x18mm
	M8x30mm
	M8x40mm

Step 23

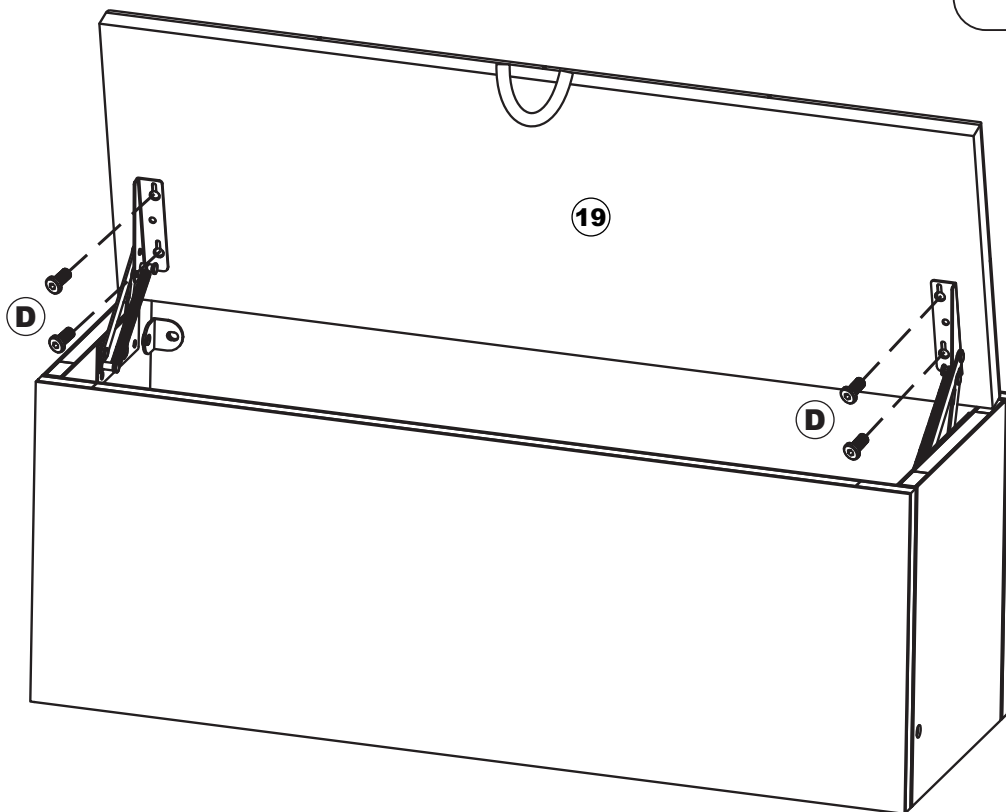
D  **x4**
M6 x15mm



	M6x10mm
	M6x15mm
	Ø5x35mm

Step 24

Tipp: Bei der Installation des Teils Nr. 24, wenn es nicht hineingelegt werden kann, müssen Sie die Schraube von Schritt 20 und Schritt 21 lösen, das Teil Nr. 24 hineingelegt und dann die Schraube festschrauben

Conseil: lors de l'installation de la pièce n ° 24, si vous ne pouvez pas y mettre, vous devez dévisser la vis de l'étape 20 à l'étape 21, après avoir mis la pièce n ° 24, puis serrer la vis



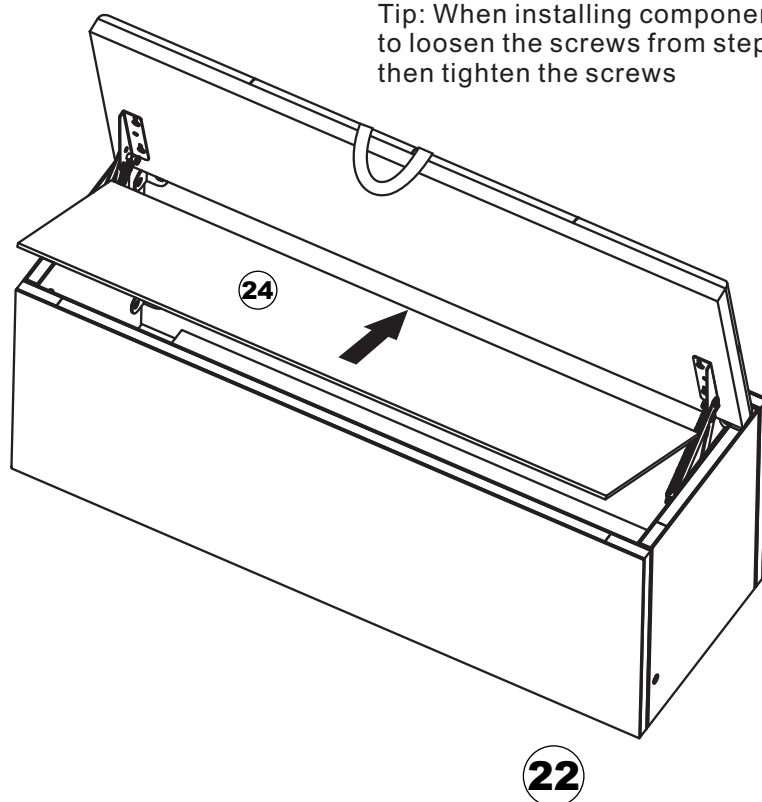

Tip: When installing component 24, if it cannot be inserted, you need to loosen the screws from steps 20 and 21, insert component 24, and then tighten the screws

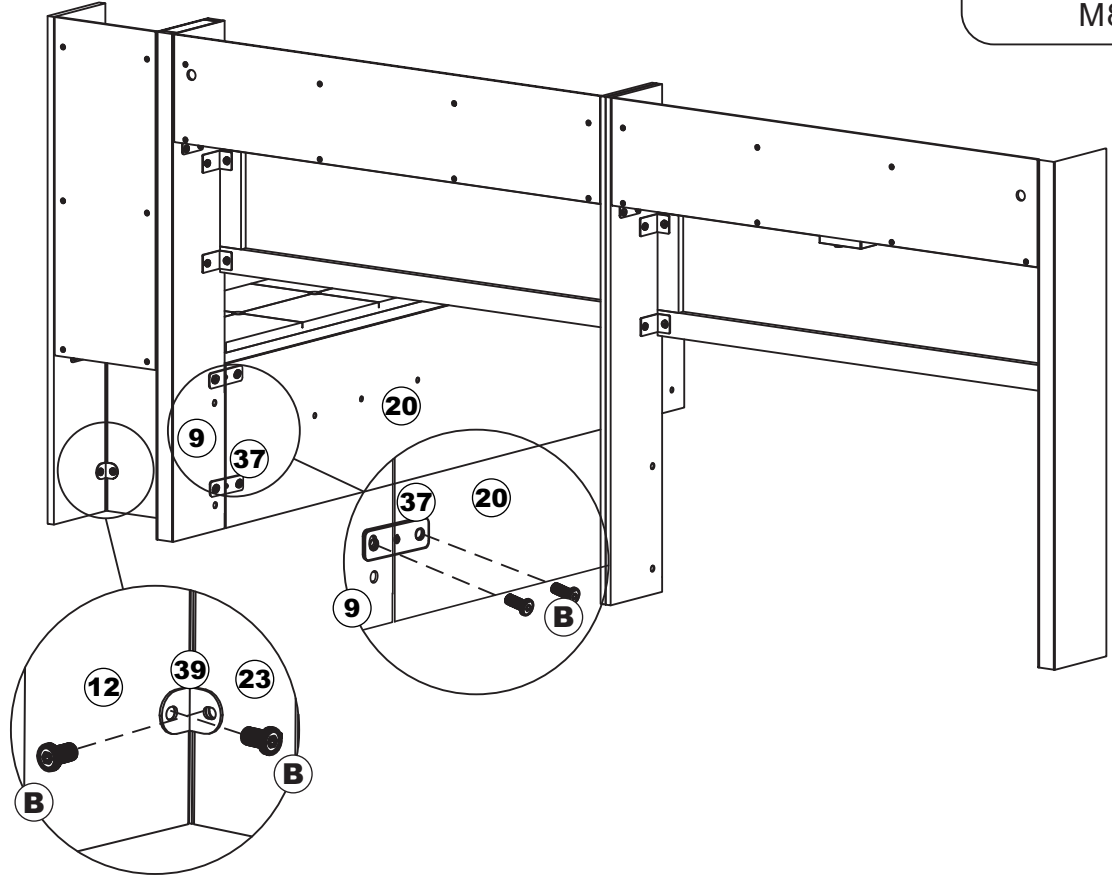

Step 25

B  **x6**
M8 x 18mm





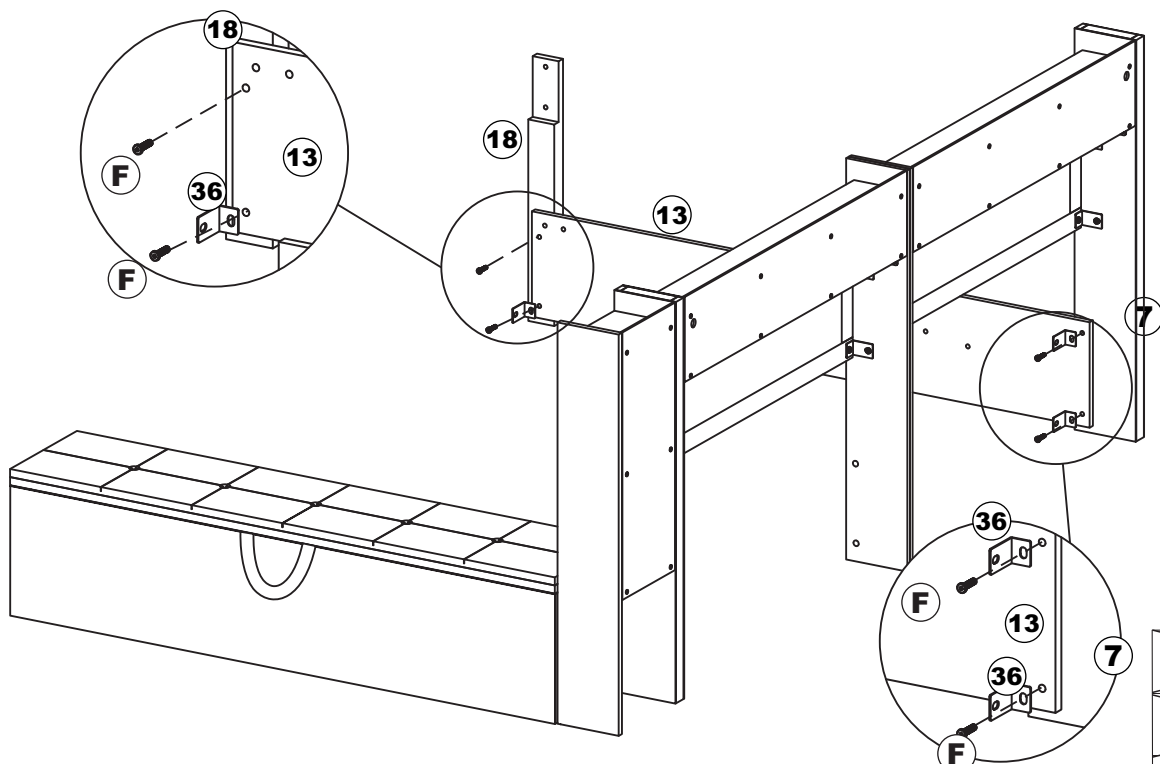

	M8x12mm
	M8x18mm
	M8x30mm
	M8x40mm

Step 26

F  **x4**
M8 x 30mm



	M8x12mm
	M8x18mm
	M8x30mm
	M8x40mm

Step 27



Part 36 is assembled on the left, with the Velcro side facing down.

Hinweis: Komponente 36 ist links montiert,
die Seite mit den Reißverschlüssen nach unten.

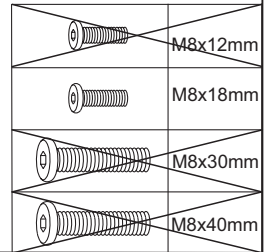
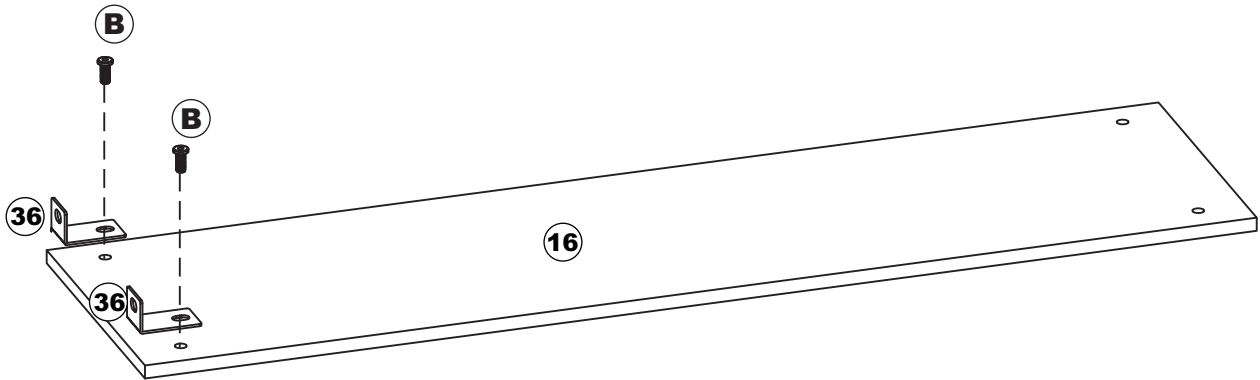



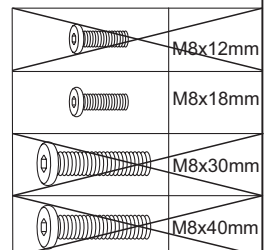
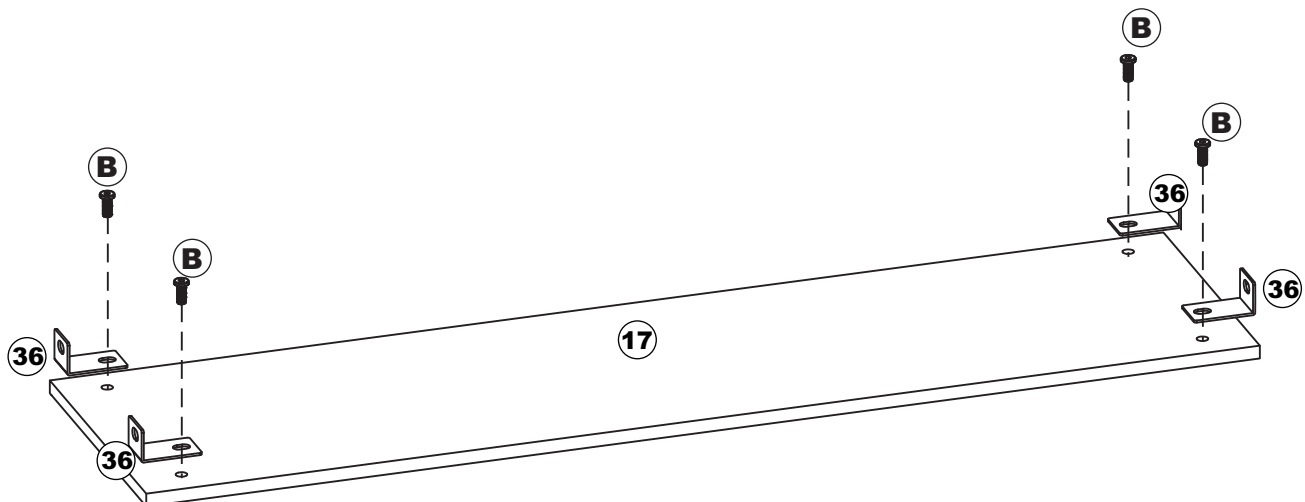

Step 28

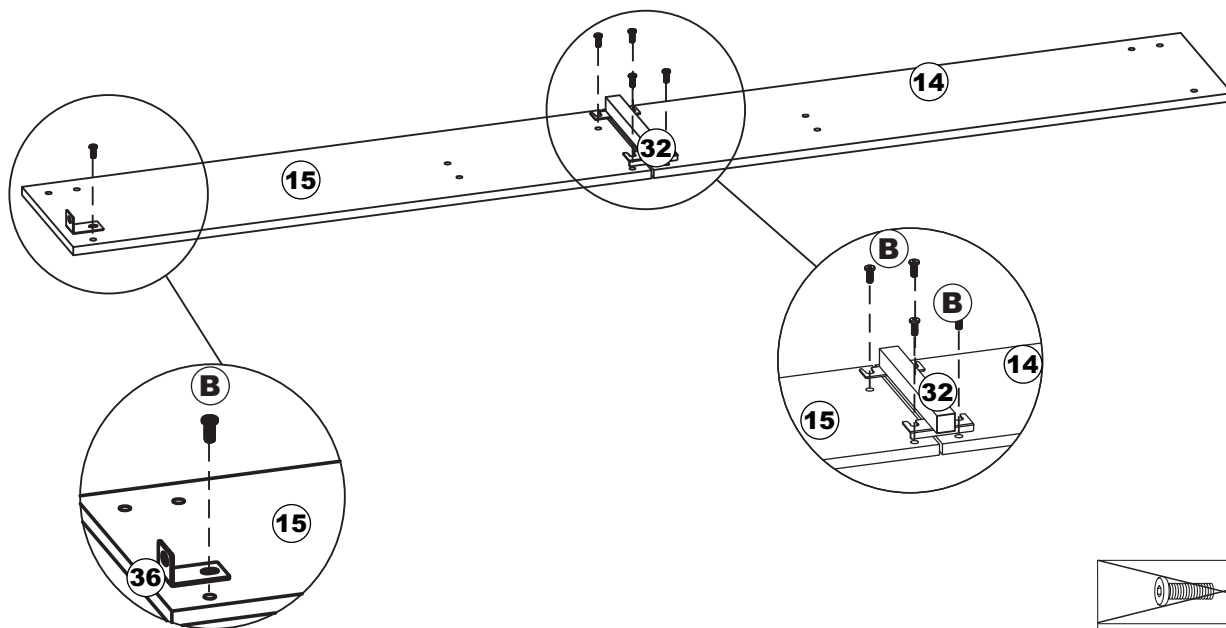

Step 29

B  **x5**
M8 x 18mm



	M8x12mm
	M8x18mm
	M8x30mm
	M8x40mm

Step 30



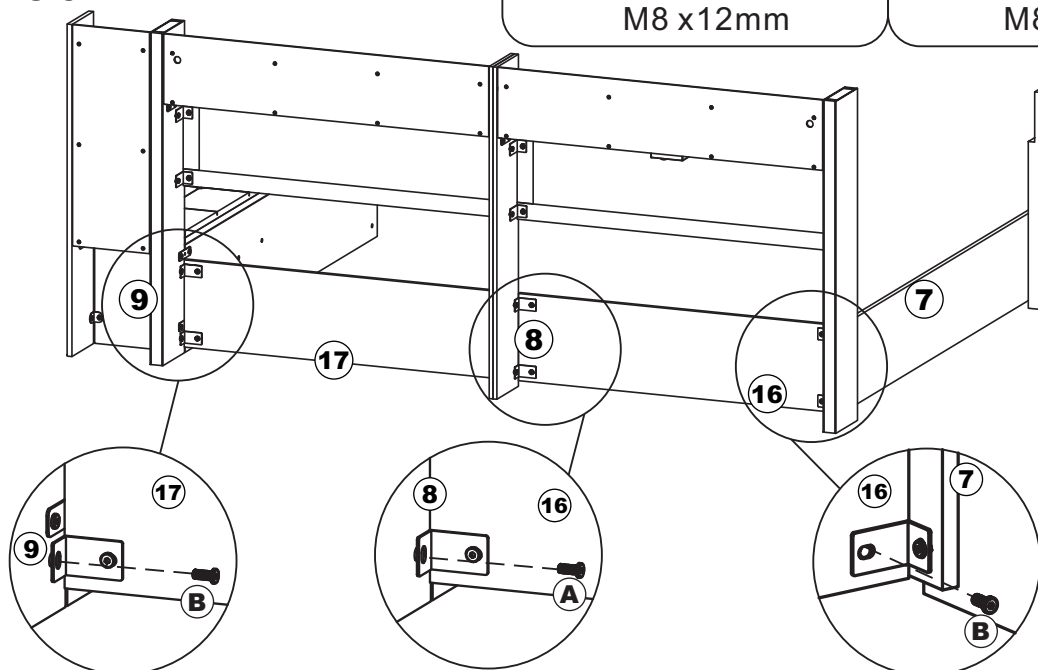

A  **x4**
M8 x 12mm

B  **x4**
M8 x 18mm



Note: During the assembly process, the side with the Velcro should be facing downwards.





Beim Zusammenbau ist die Seite mit den Magic-Stickern nach unten zu orientieren.

	M8x12mm
	M8x18mm
	M8x30mm
	M8x40mm

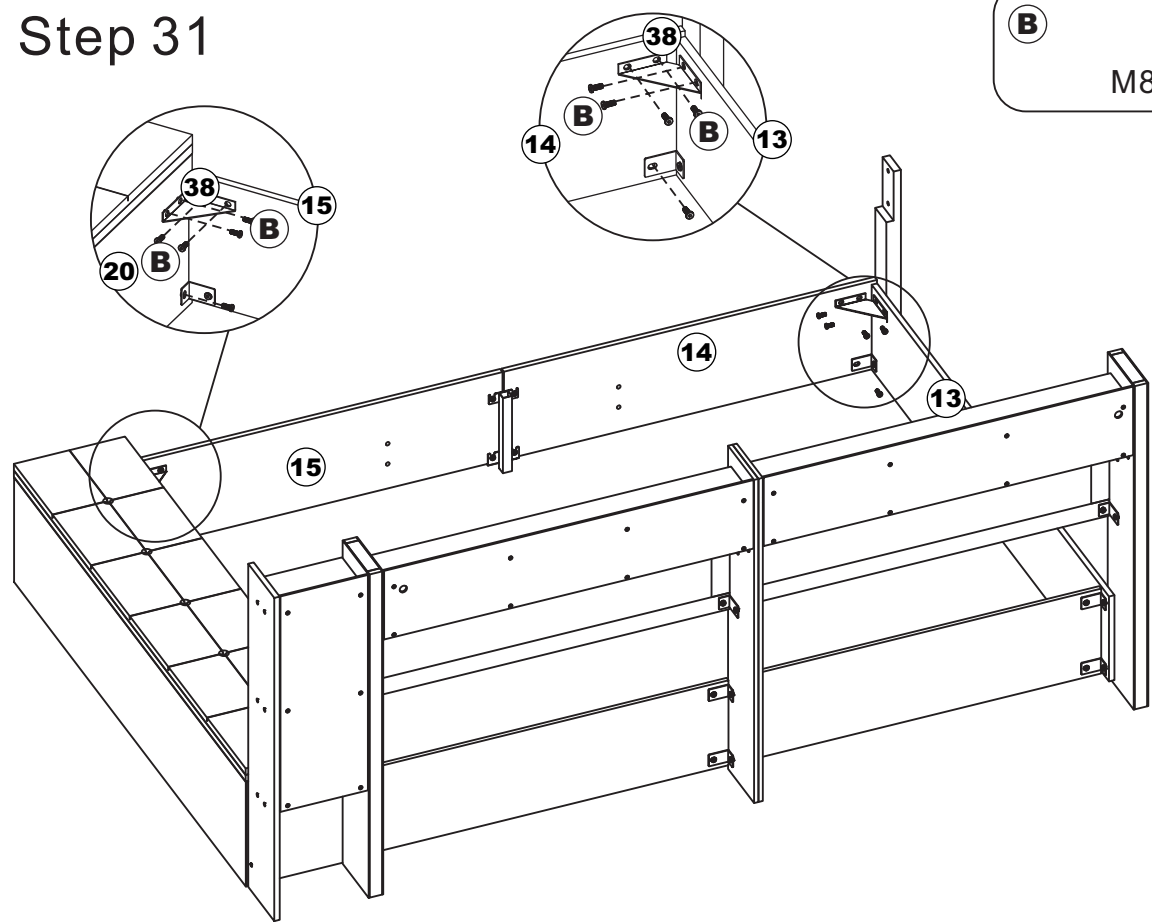
Step 31

B  **x10**
M8 x 18mm





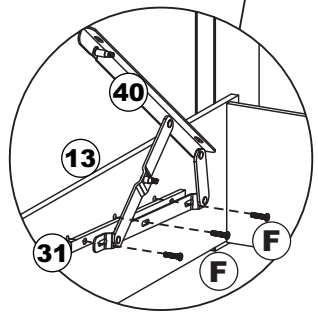
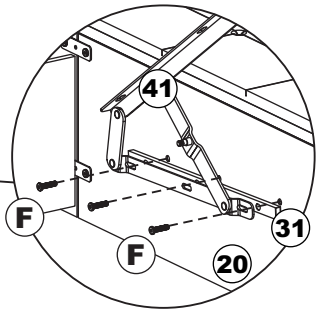
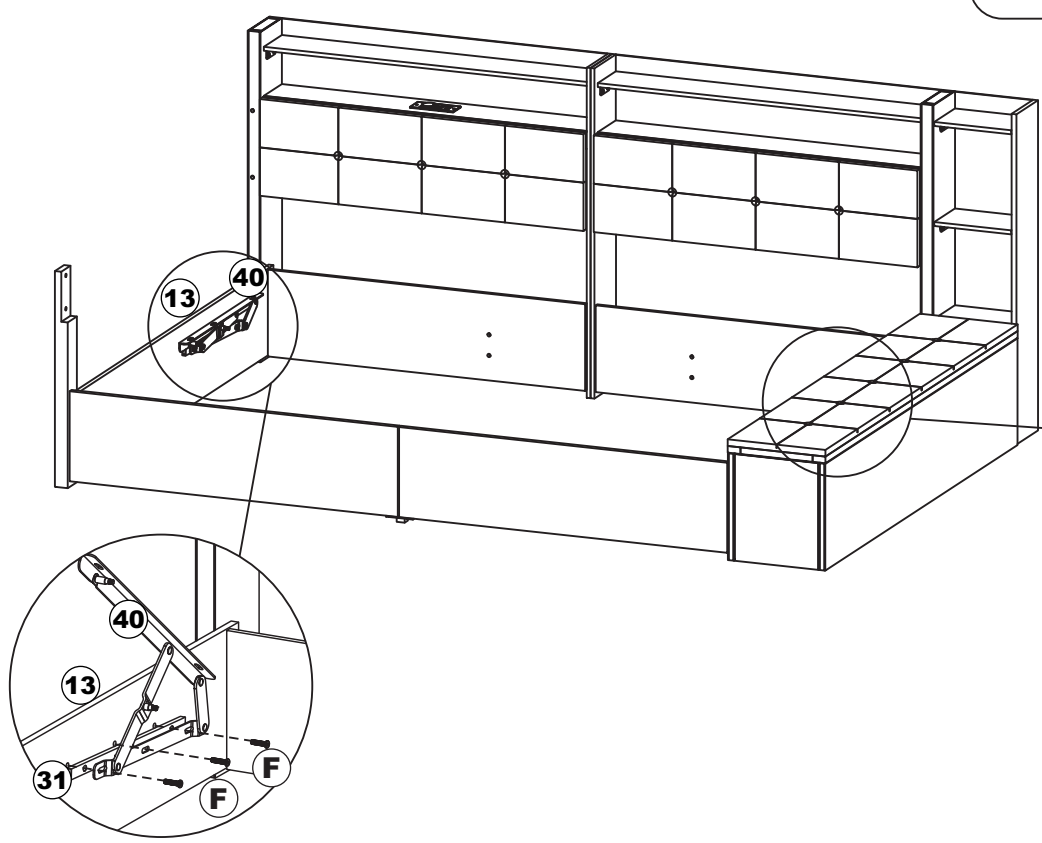

	M8x12mm
	M8x18mm
	M8x30mm
	M8x40mm

Step 32

F  **x6**
M8 x 30mm





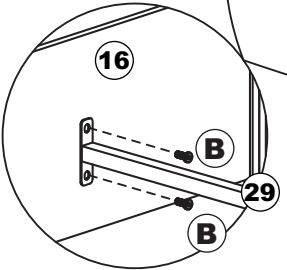
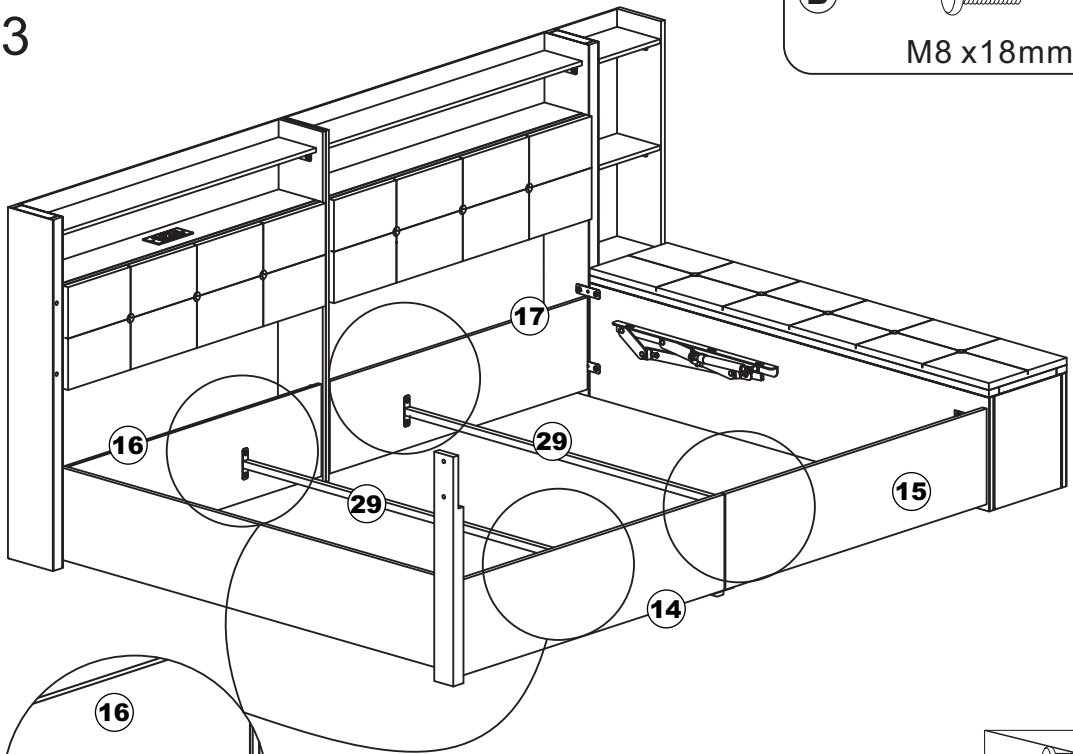

	M8x12mm
	M8x18mm
	M8x30mm
	M8x40mm

Step 33

B  **x8**
M8 x18mm





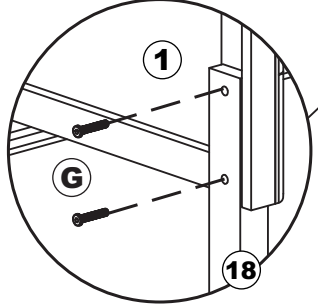
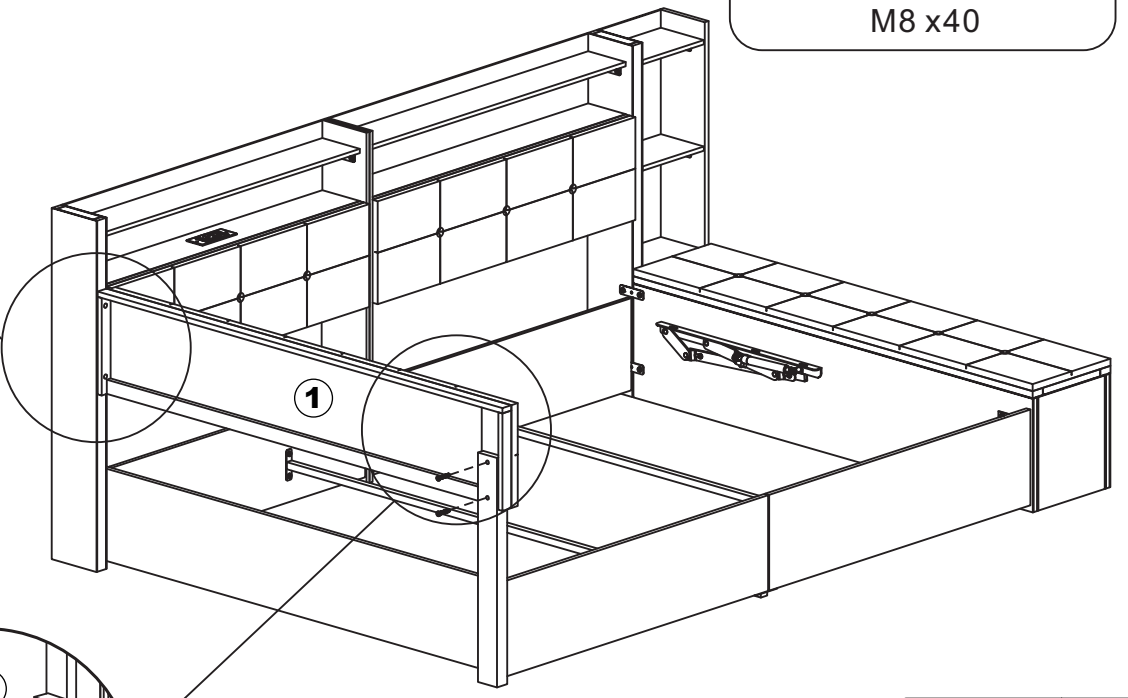
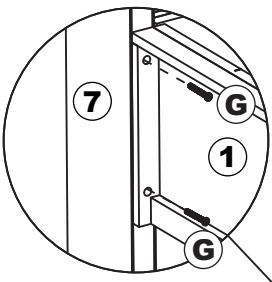

	M8x12mm
	M8x18mm
	M8x30mm
	M8x40mm

Step 34

G  **x4**
M8 x40



	M8x12mm
	M8x18mm
	M8x30mm
	M8x40mm

Step 35

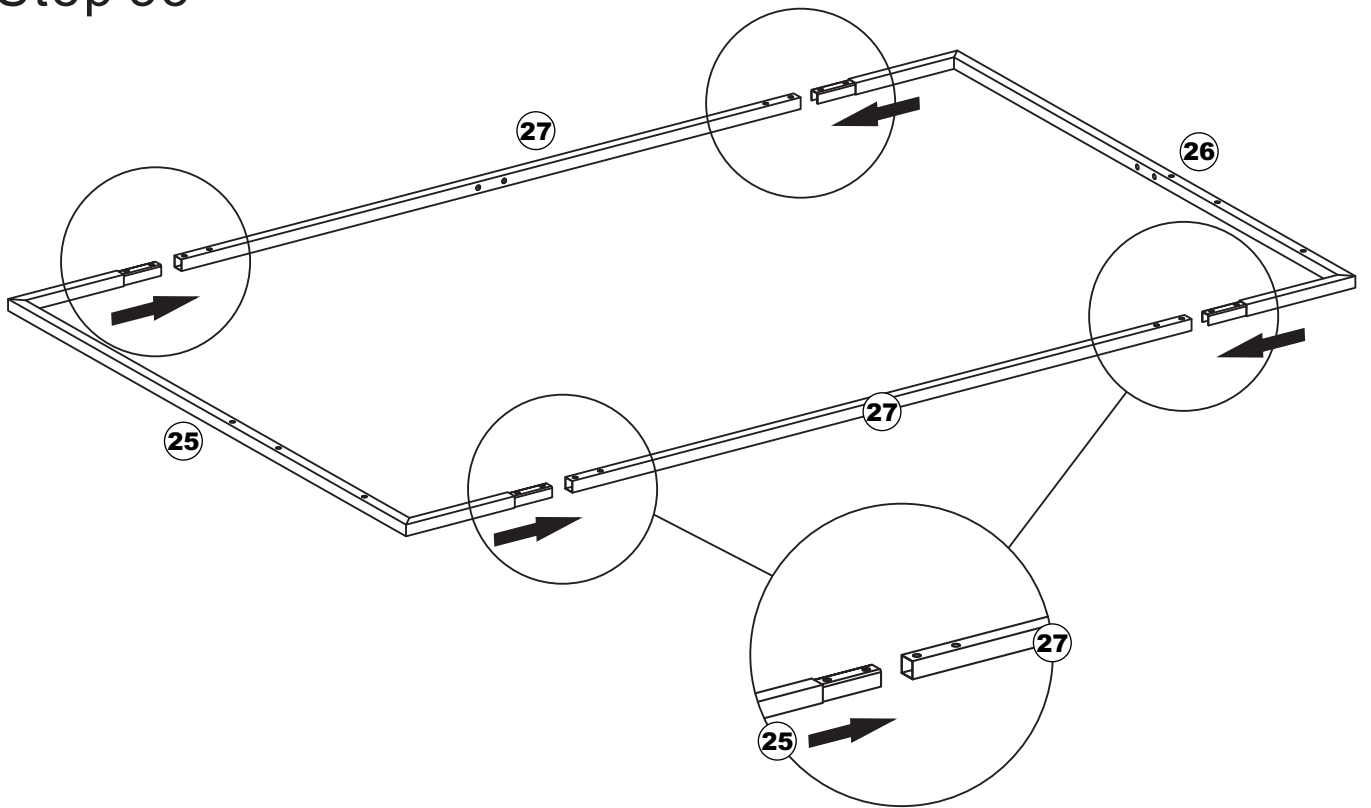



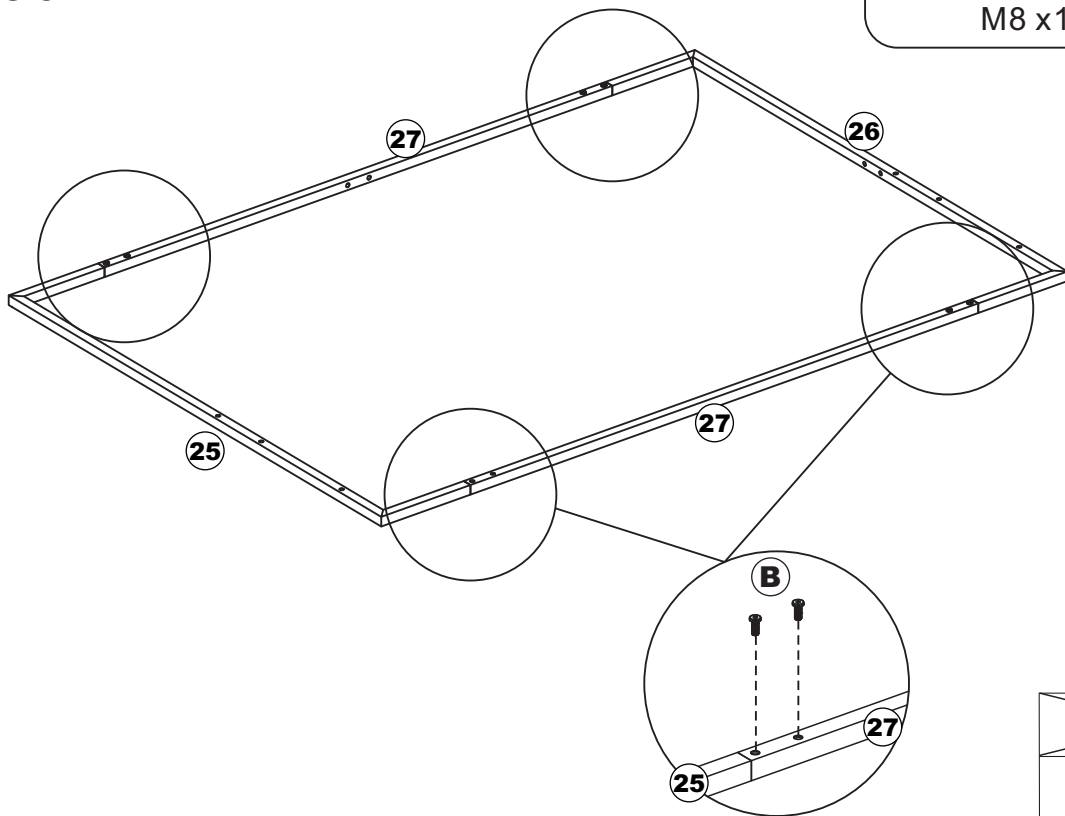

Step 36

B  **x8**
M8 x18mm







28

	M8x12mm
	M8x18mm
	M8x30mm
	M8x40mm

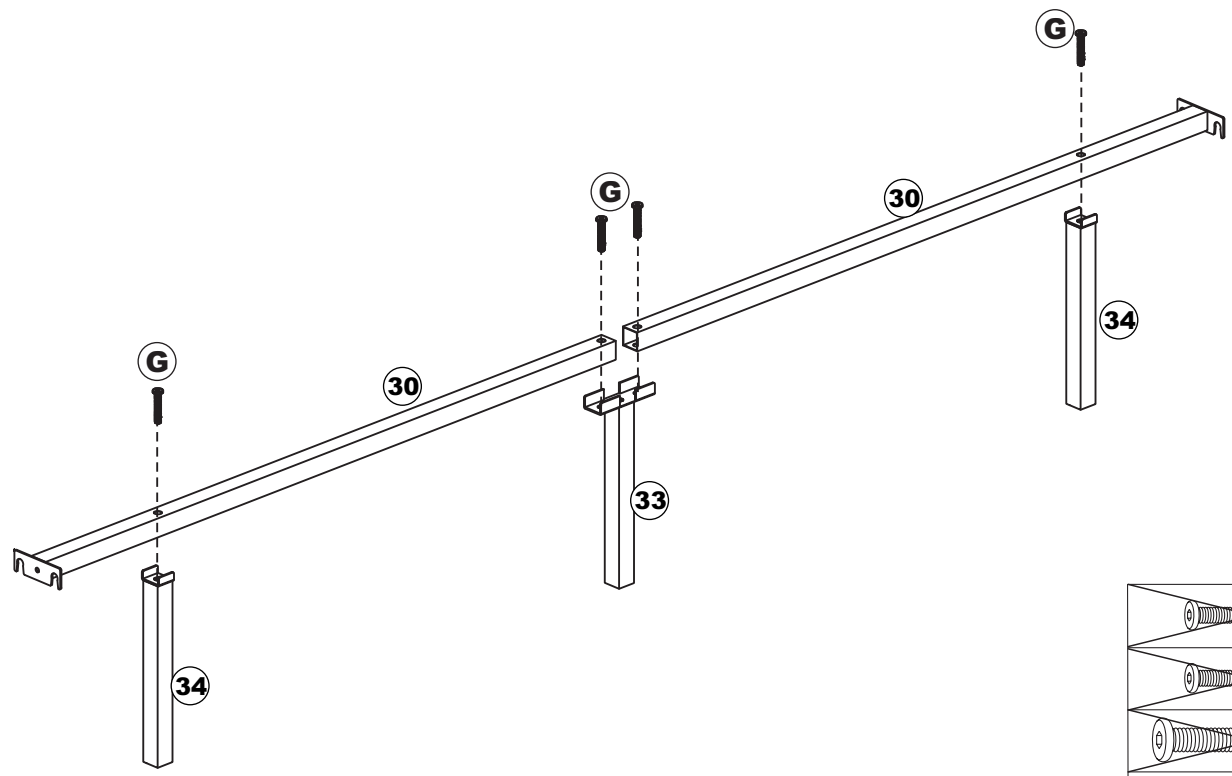
Step 37

G  **x4**
M8 x40mm





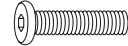

	M8x12mm
	M8x18mm
	M8x30mm
	M8x40mm

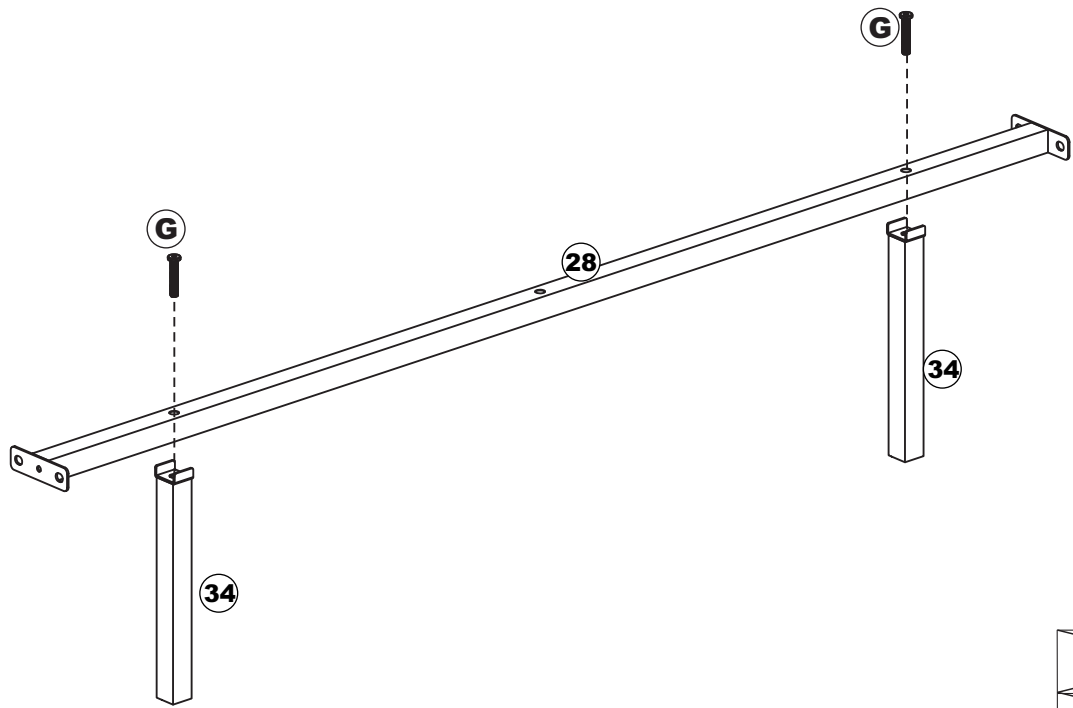
Step 38

G  **x2**
M8 x40mm







	M8x12mm
	M8x18mm
	M8x30mm
	M8x40mm

29

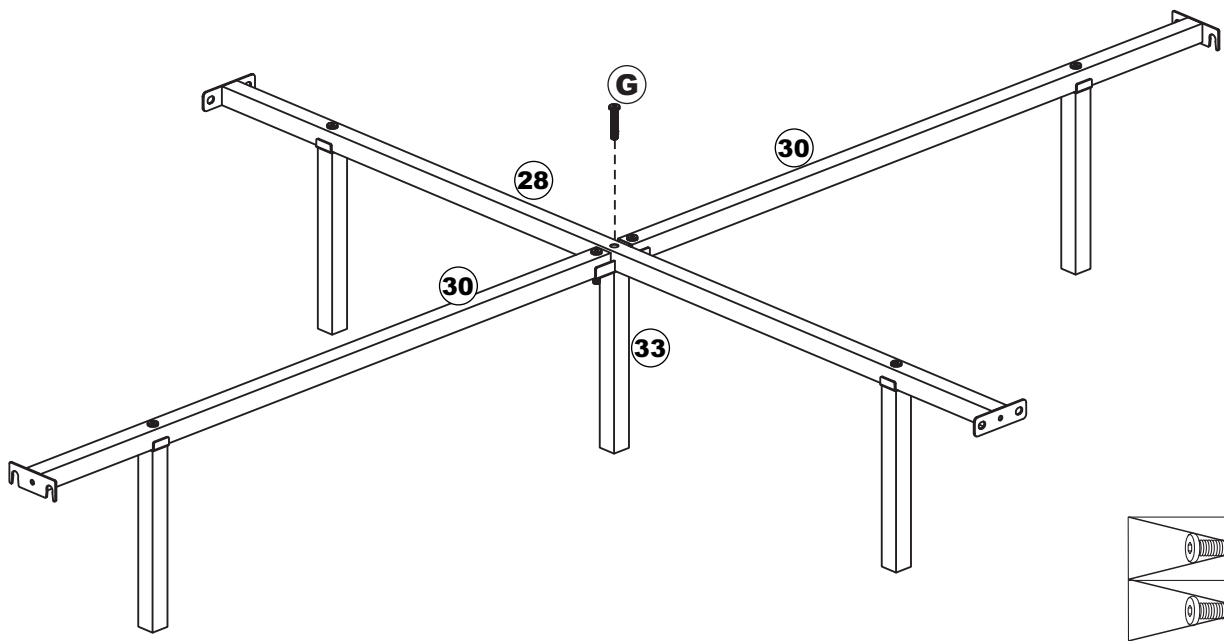
Step 39

G  **x1**
M8 x40mm





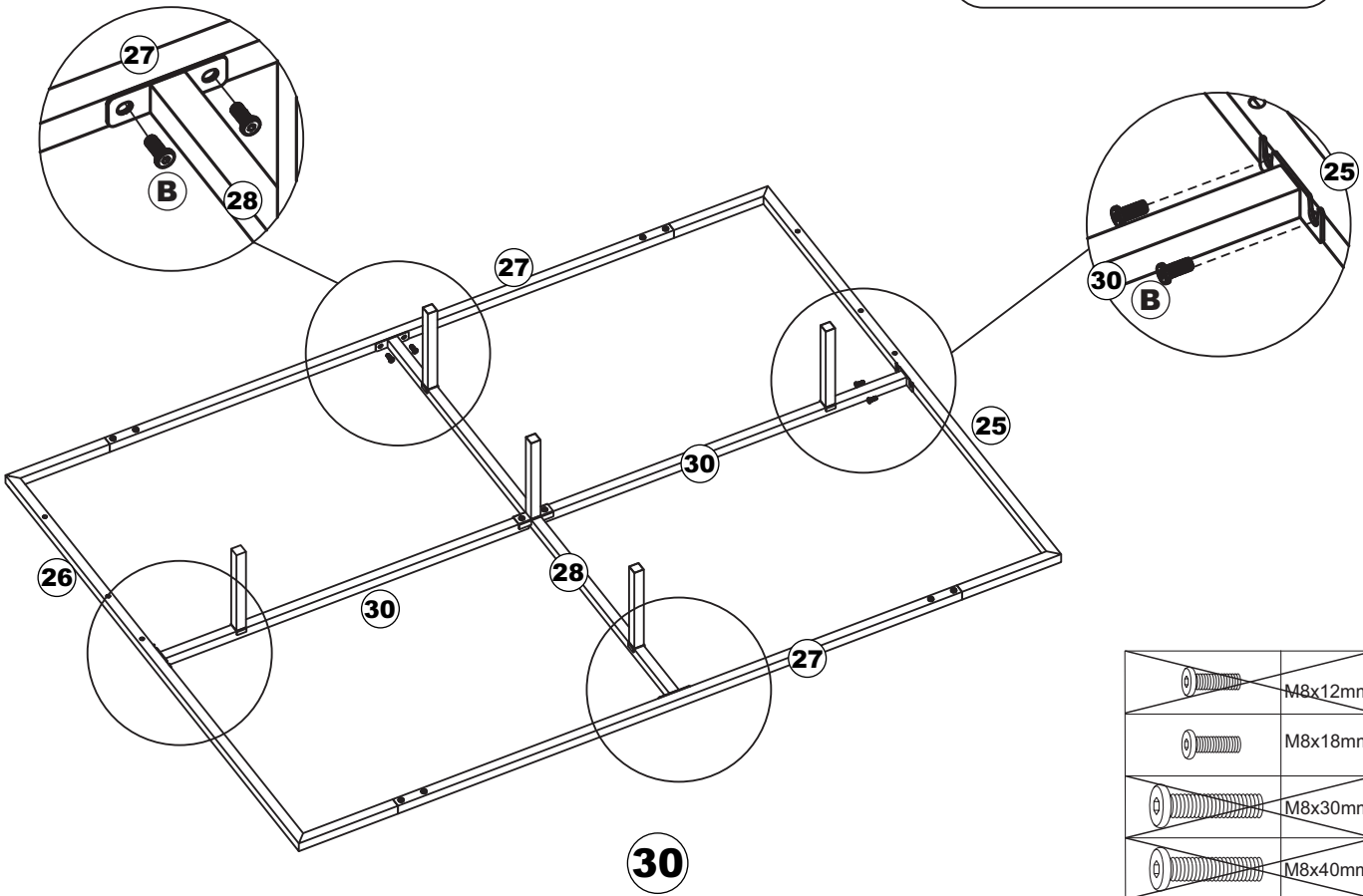

	M8x12mm
	M8x18mm
	M8x30mm
	M8x40mm

Step 40

B  **x8**
M8 x18mm







	M8x12mm
	M8x18mm
	M8x30mm
	M8x40mm

Step 41

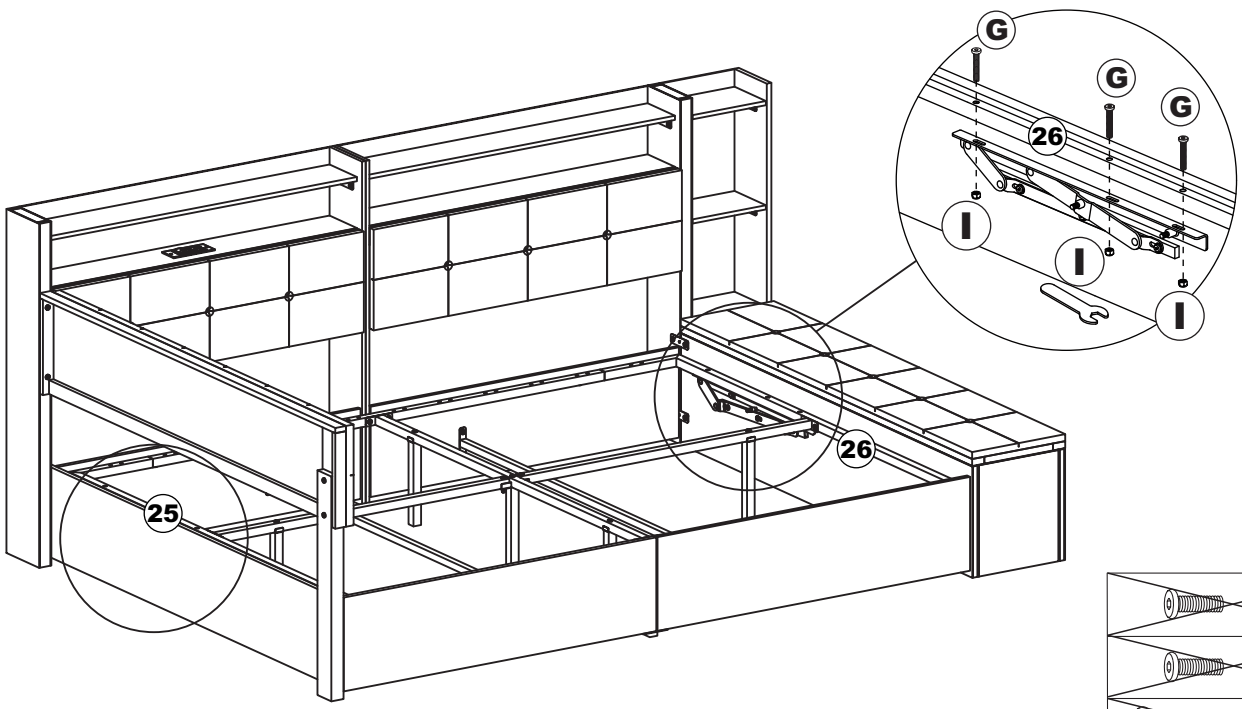
I  **x6**
M8 nut

G  **x6**
M8 x40mm



	M8x12mm
	M8x18mm
	M8x30mm
	M8x40mm

Step 42

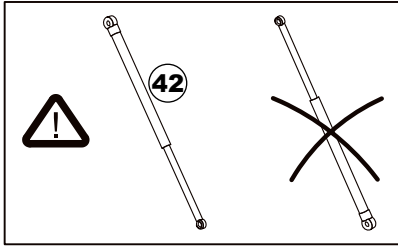

I  **x4**
M8 nut

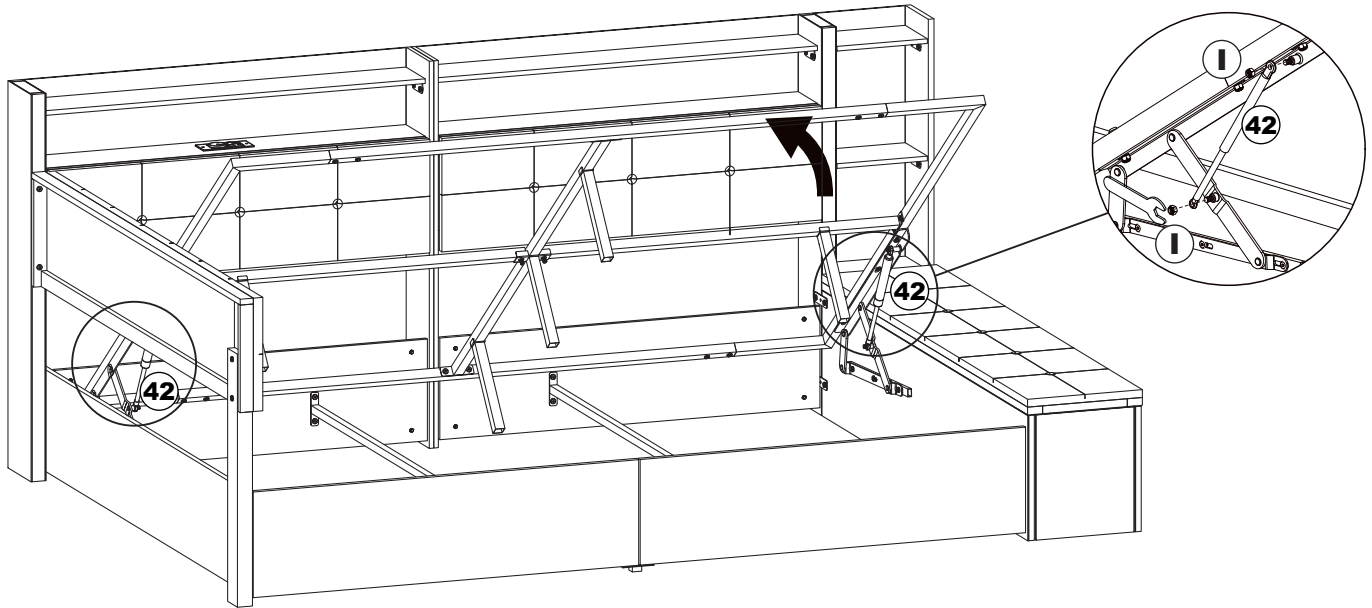

Step 43

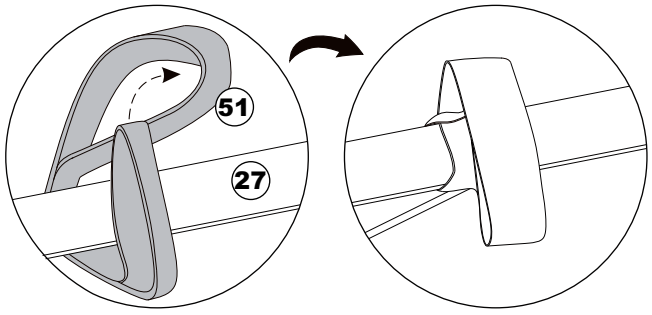
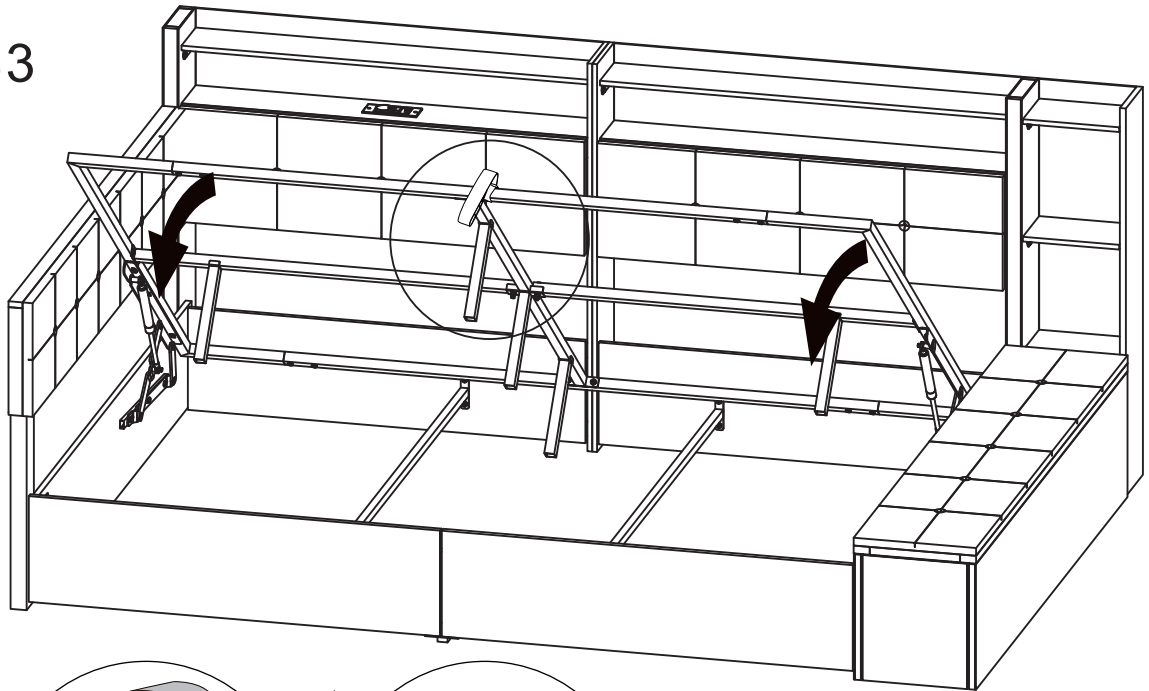

Step 44

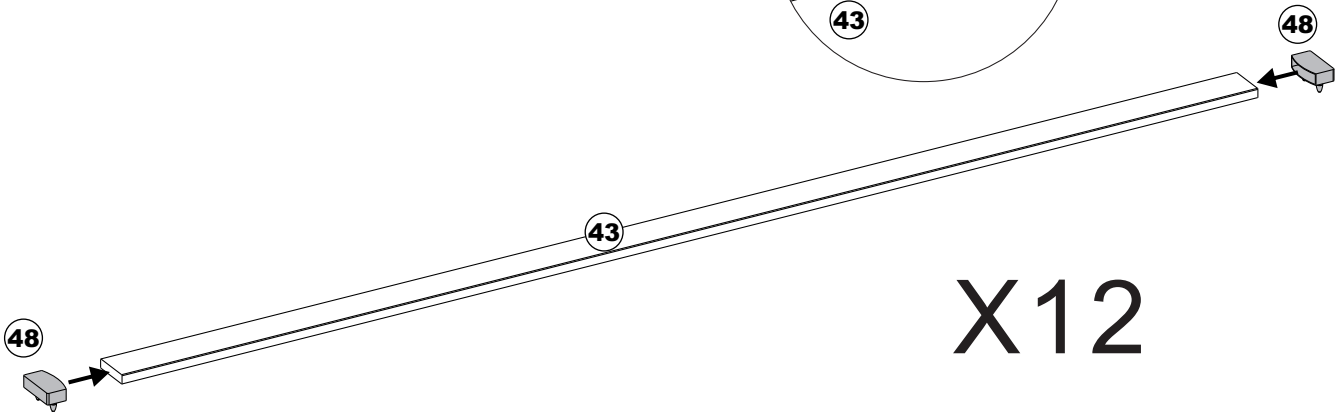
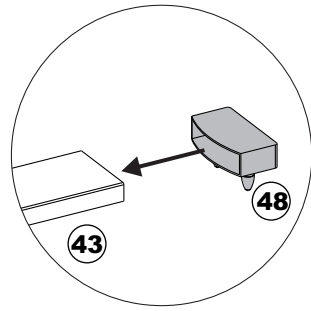

X12

Step 45

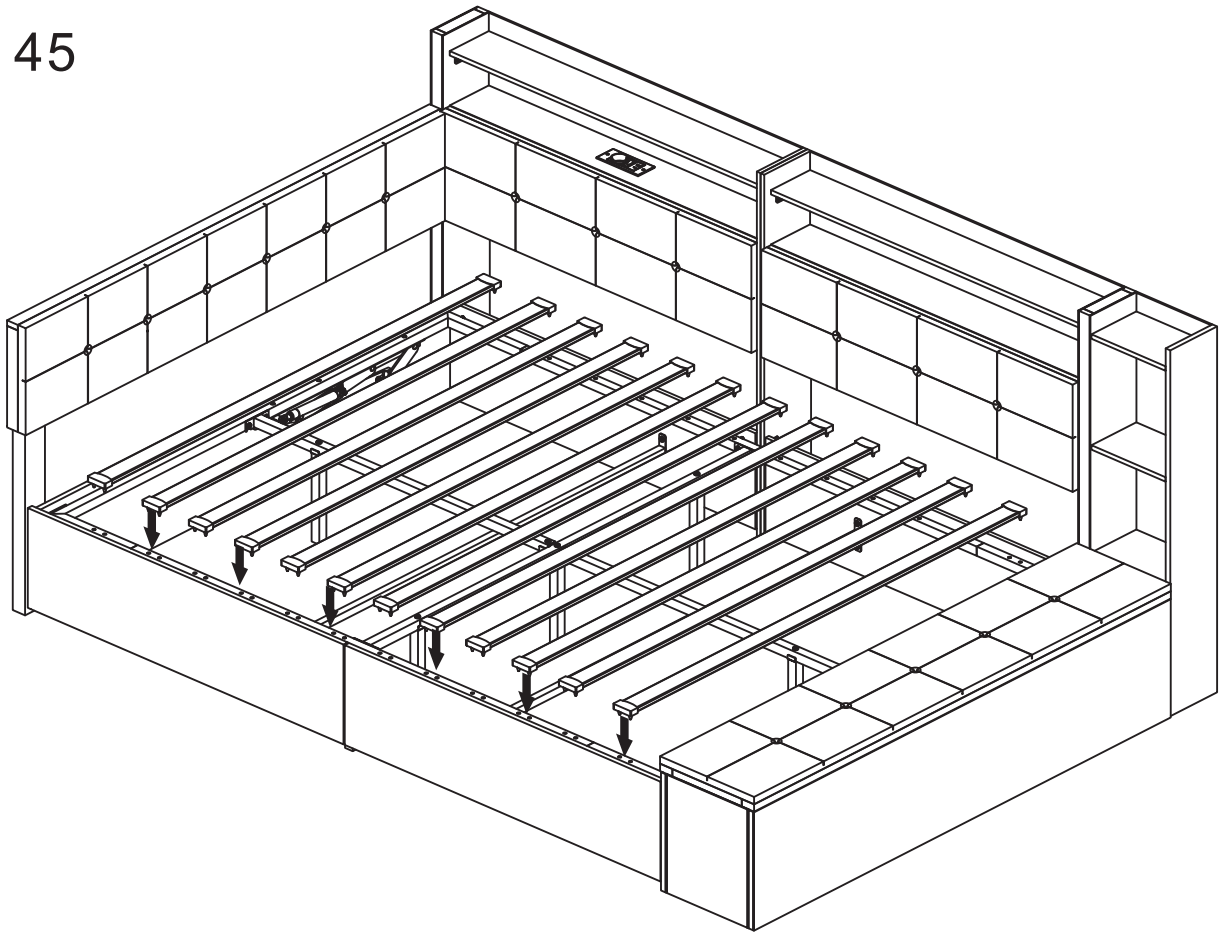

Step 46

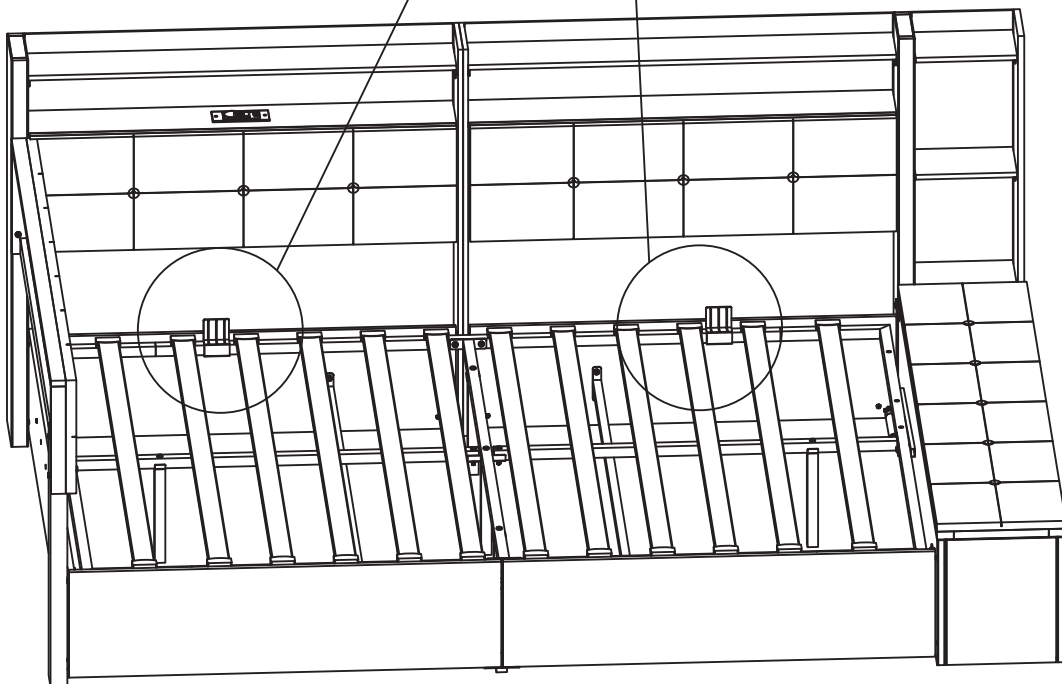
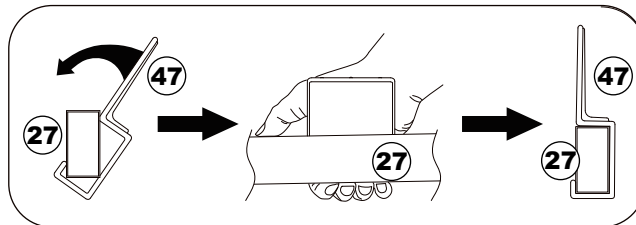

Step 47



1. Please align the position to remove the red sticker behind the light strip carefully when installing, and then paste it to the product.
2. Please tear off the light strip slowly when changing the position to prevent breaking.
1. Bitte richten Sie die Position aus, um den roten Aufkleber hinter dem Lichtstreifen bei der Installation vorsichtig zu entfernen, und fügen Sie ihn dann auf das Produkt ein.
2. Bitte reißen Sie den Lichtstreifen langsam ab, wenn Sie die Position ändern, um zu verhindern, dass Sie brechen.
1. S'il vous plaît aligner la position pour retirer l'autocollant rouge derrière la bande de lumière soigneusement lors de l'installation, puis collez-le sur le produit.
2. S'il vous plaît déchirer lentement la bande de lumière lorsque vous changez de position pour empêcher la cassure.

The light strip goes out from the outside to the inside

Der Lichtstreifen geht aus von außen nach innen

La bande lumineuse sort de l'extérieur à l'intérieur

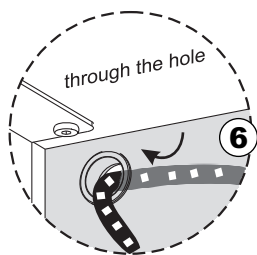

Tear off the film on the light strip

Reiß die Folie auf dem Lichtband ab.

Arrachez le film sur la bande de lampe

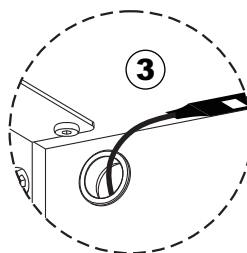
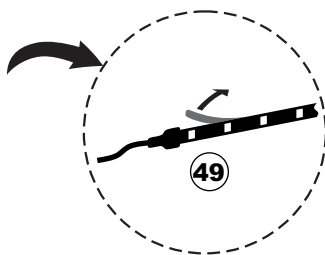

The light strip needs to pass through this position

Der Lichtstreifen muss durch diese Position

La bande de lumière doit traverser cette position

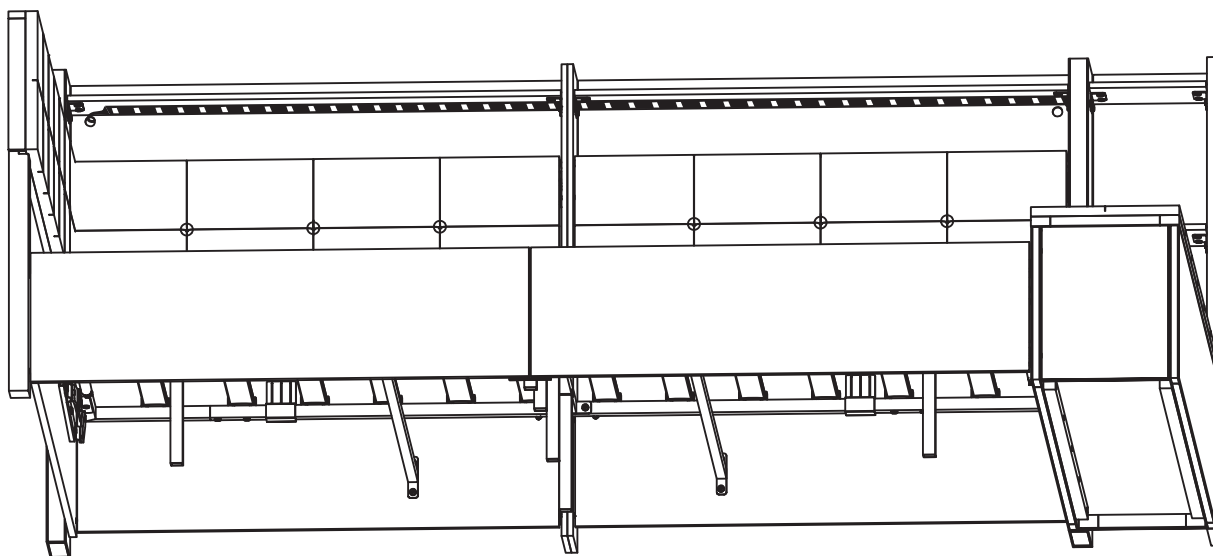
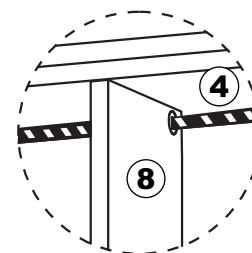

Step 48

Attention: When you turn the bed over, be sure to move the pneumatic support of the bed to avoid accidental injury.

Hinweis: Wenn Sie den Bettkörper umdrehen, achten Sie darauf, dass sich die pneumatische Halterung des Bettkörpers bewegt, um Fehlverletzungen zu vermeiden.

Remarque: lorsque vous retournez le corps du lit, faites attention à ce que le support pneumatique du corps du lit bouge pour éviter les blessures par erreur.

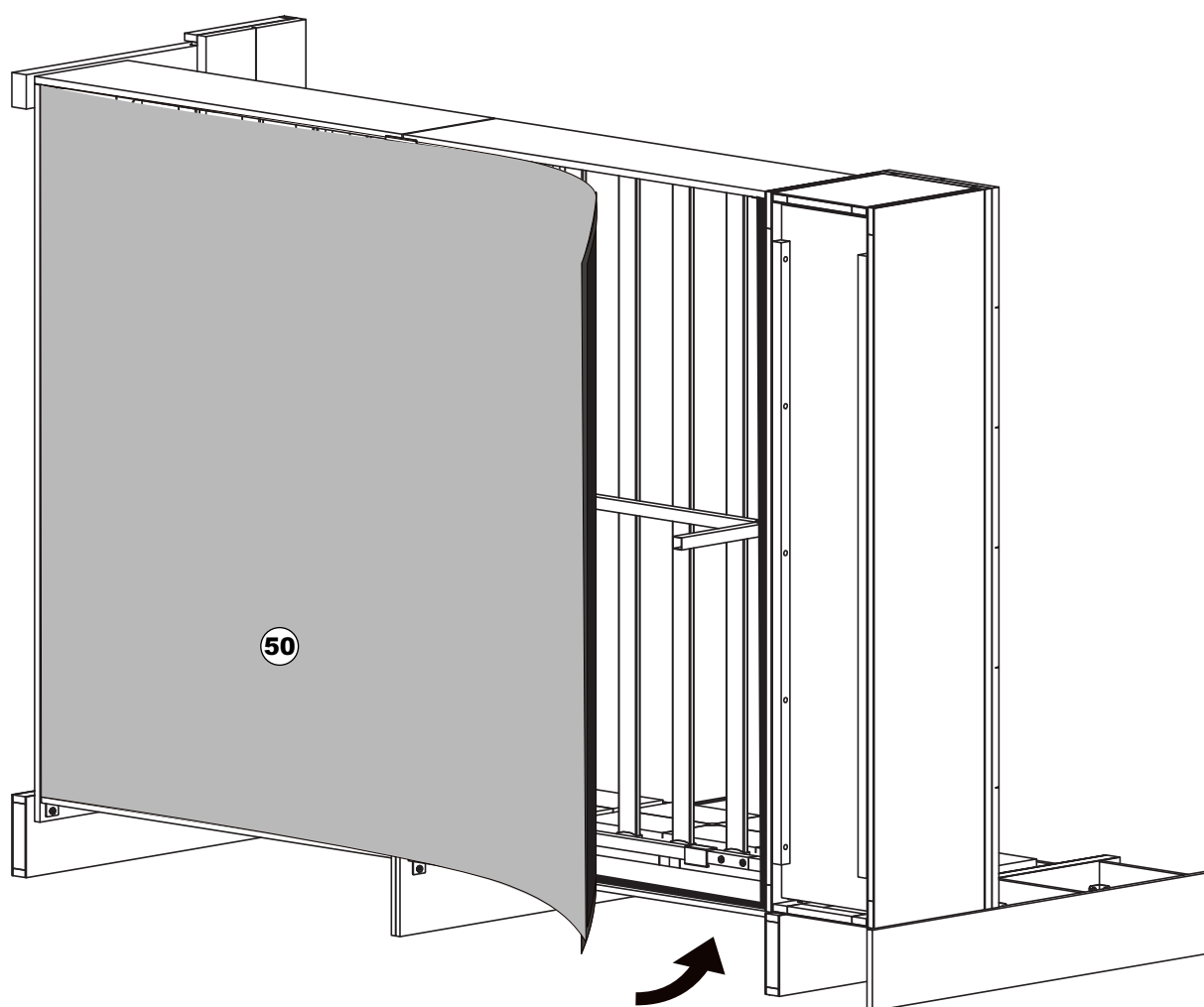

Velcro

LotusLantern APP Manual

1. Software Overview

1.1 Overview

LotusLantern is a mobile APP to control LED strip by both IOS and Android phones. The traditional control ways like infrared, 433MHz, 2.4GHz and others old wired ways will be replaced by mobile phone control way with convenient, powerful and scalable features.

Through this mobile APP, you can not only control the color, brightness and color temperature of the LED strips but also set up all kinds of fancy flash mode; Also this APP can change the light of the LED strip according to the rhythm of the music. This APP can set and control several LED strips through Bluetooth and the operation is very simple, easy to learn and easy to use.

1.2 Features

- Adjust color LED strips with 60,000 colors to change color and brightness and adjust monochrome LED strips to change brightness and color temperature
- Play music or turn on a sound playback device, you can let the light change the color and brightness with the rhythm of music, the music rhythm beautiful
- Inside multiple setting mode for color change and control LED strips without mobile
- Long distance control with omni-directional antenna, and many-to-many group control mode
- Once the connection is successful, connect automatically next time

1.3 Performance

LotusLantern APP is easy for use as well as great compatible with all kinds of smart phones; After the actual test of hundreds of mobile phones verification, the compatibility is above 95% of mobile phones in the market. APP is small and convenient, it consumes less system resources, so the requirements of the mobile configuration are low. Control delay is small, the operation feels good, light control is smooth with people's visual sense.

2. Operating Environment

This APP program requires phones of system above Android 4.3 and IOS 8.0. Mobile phone configuration is not limited.

3. Instructions

Note: Android version and IOS version download and use the same method, here in the Android version as an example.

3.1 APP Download

Scan the QR code

IOS and Android systems can download the "LotusLantern" APP by scanning the QR code. Open the browser or other tools with "Scan QR code" function, scan the "LotusLantern" QR code as below:



1

3.2 App Operation

(1) Click on the LotusLantern APP icon, enter the APP page:

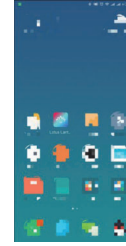

(2) After entering the APP interface, if Bluetooth is not enabled, "an application wants to enable the Bluetooth function of this device." Click [Allow]

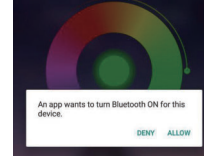

(3) switch to color and brightness interface:

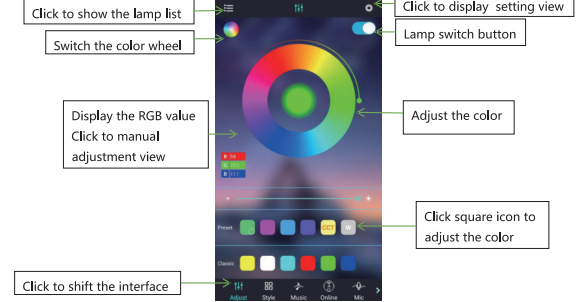

2

(4) click to show the lamp list, view lamp list:

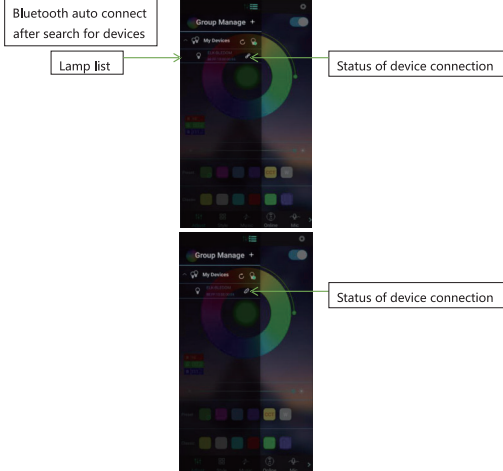

(5) Click to RGB manual adjustment view:



3

(6) switch to the mode interface:

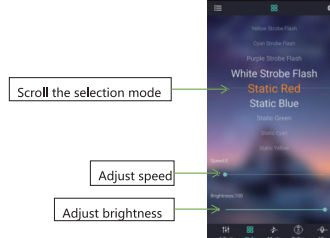

(7) switch to the music rhythm interface:

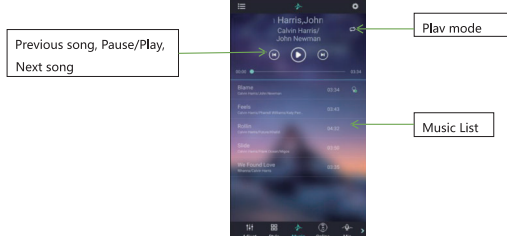

4

(8) Switch to the online music interface:

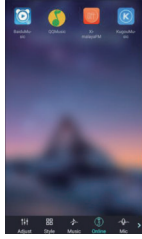

(9) Switch to the microphone rhythm interface:

Music rhythm through cell phone microphone

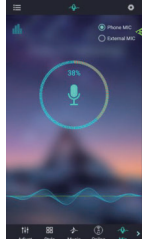

Switch phone microphone and external microphone

Music rhythm through the microphone on the product

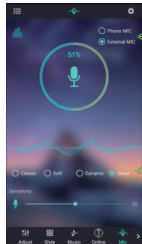

Switch phone microphone and external microphone

4-style rhythm

Change the sensitivity of MIC to match the sound

5

(10) Switch to the schedule interface:

Set the time of Light-On

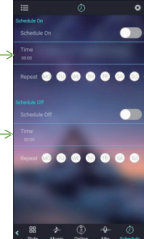

Enable or disable the Light-On function

Repeat setting
No selection for once Light-On

Set the time of Light-Off

Enable or disable the Light-Off function

Repeat setting
No selection for once Light-Off

(11) Switch to the modify pin sequence interface:

Click to save the new assignment

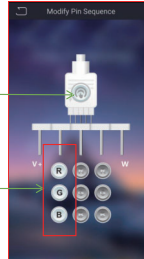

Change the real color of this line

Technical parameters:

Working temperature: -20-60°C (-4 F°-140 F°)

Power supply voltage: DC5-24V

Output: 3 Loops

Static power consumption: <0. 5W

Output current: <3A(each circuit)5V <30W 12V <108 24V <21 6W

6



Certificate of Conformity

Certificate No. : SIT190523591401E
Product : LED Strip Light
Model : 2835, 5050, 3528, 3014, 2110, 335, 5630
Trade Mark : N/A
Applicant : SHENZHEN KEWANG PHOTOELECTRIC CO., LTD.
Address : Floor 2, Build A, ChuangFu Industrial Park, AiQun Road, ShiYan Street, BaoAn District, ShenZhen
Manufacturer : SHENZHEN KEWANG PHOTOELECTRIC CO., LTD.
Address : Floor 2, Build A, ChuangFu Industrial Park, AiQun Road, ShiYan Street, BaoAn District, ShenZhen

The above products have been tested by us with listed standards and found in compliance with the council EMC 2014/30/EU. It is possible to use CE marking to demonstrate the compliance with this EMC.

Test standards:	Report(s) Number	Issued By	Issued Date
EN 55015:2013+A1:2015 EN 62493:2015 EN 61547:2009 EN 61000-3-2:2014 EN 61000-3-3:2013	SIT190523591401ER	SIT	May 30, 2019

This certificate of conformity is not transferable and based on an evaluation of a sample of the above mentioned product.



Authorized Signer: _____

Department Manager

Date: May 30, 2019

Shenzhen SIT Testing Technology Co., Ltd.

Hotline:400-6633-940

Tel: (86)-0755-29173399

Fax: (86)-0755-29179933

Http://www.sit-cert.com



Certificate of Conformity

Certificate No. : SIT190523591401S
 Product : LED Strip Light
 Model : 2835, 5050, 3528, 3014, 2110, 335, 5630
 Trade Mark : N/A
 Applicant : SHENZHEN KEWANG PHOTOELECTRIC CO., LTD.
 Address : Floor 2, Build A, ChuangFu Industrial Park, AiQun Road, ShiYan Street, BaoAn District, ShenZhen
 Manufacturer : SHENZHEN KEWANG PHOTOELECTRIC CO., LTD.
 Address : Floor 2, Build A, ChuangFu Industrial Park, AiQun Road, ShiYan Street, BaoAn District, ShenZhen

The above products have been tested by us with listed standards and found in compliance with the council RoHS 2011/65/EU and revise directive(EU)2015/863.

It is possible to use RoHS marking to demonstrate the compliance with this RoHS.

Test standards:	Report(s) Number	Issued By	Issued Date
IEC 62321-3-1:2013 IEC 62321-5:2013 IEC 62321-6:2015 IEC 62321-7-1:2015 IEC 62321-4:2013+AMD1:2017 IEC 62321:2008 ANNEX C	SIT190523591401SR	SIT	May 30, 2019

This certificate of conformity is not transferable and based on an evaluation of a sample of the above mentioned product.

RoHS



Authorized Signer: _____

Department Manager

Date: _____ May 30, 2019

Shenzhen SIT Testing Technology Co., Ltd.

Hotline:400-6633-940

Tel: (86)-0755-29173399

Fax: (86)-0755-29179933

Http://www.sit-cert.com

Certificate of Conformity

No.: LP24060215C01-01

The following products have been tested by us with the listed standards and found in compliance with the council EMC directive 2014/30/EU. It is demonstrative for the compliance with this EMC Directive.

Applicant : Dongguan Yali Electric Appliance Co.,Ltd
Address : 8 / F, Building 9, No. 6, Yuyuan 4th Road, Yuyuan Industrial Zone, Huangjiang Town, Dongguan City, Guangdong Province
Product : Strip power supply
Model No. : YL-SKCE-901, YL-SKCE-902, YL-SKCE-903, YL-SKCE-905, YL-SKCE-906, YL-SKCE-907, YL-SKCE-908, YL-SKCE-909, YL-SKCE-901A, YL-SKCE-902A, YL-SKCE-903A, YL-SKCE-905A, YL-SKCE-906A, YL-SKCE-907A, YL-SKCE-908A, YL-SKCE-909A
Test Standards : EN 55032:2015+A11:2020+A1:2020
EN 55035:2017+A11:2020
EN IEC 61000-3-2:2019+A1:2021
EN 61000-3-3:2013+A1:2019+A2:2021



The CE marking may be used if all relevant and effective EC Directives/Regulations are complied with.

Manager: Frank Shen
Date: October 31, 2024

Dongguan Lepont Testing Service Co., Ltd.

Tel.:86-769-83086888 Fax.:86-769-83096886

Room 102, Building 11, No.7, Houjie Science And Technology Avenue, Houjie, Dongguan, Guangdong, China

The statement is based on a single evaluation of one sample of above mentioned products. It does not imply an assessment of the whole production and does not permit the use of the test lab's logo.

Shenzhen ZKT Technology Co., Ltd.
 1/F, No. 101, Building B, No. 6, Tangwei Community Industrial Avenue,
 Fuhai Street, Bao'an District, Shenzhen, China



Certificate of Compliance

Certificate Number: ZKT-25070215182C

Certificate's Holder : Dongguan Yihong Hardware Electronics Co., Ltd
 Room 1106, No.2, Shangheng Road, Chang' an Town,
 Dongguan
Manufacturer : Dongguan Yihong Hardware Electronics Co., Ltd
 Room 1106, No.2, Shangheng Road, Chang' an Town,
 Dongguan
Trade Mark : N/A
Product : LED controller
Model(s) : YH-6183
 YH-252, YH-284, YH-290, YH-287, YH-358, YH-360, YH-6180,
 YH-6184

Requirement	Standard	Report No.
Art.3.1(a) Safety	EN IEC 62368-1:2024+A11:2024	ZKT-25070215183S
Art.3.1(a) Health	EN IEC 62311:2020 EN 50665:2017	ZKT-25070215182E-1
Art.3.1(b) EMC	ETSI EN 301 489-1 V2.2.3 (2019-11) ETSI EN 301 489-17 V3.3.0 (2024-07)	ZKT-25070215182E-2
Art.3.2 Radio	ETSI EN 300 328 V2.2.2 (2019-07)	ZKT-25070215182E-3

This Attestation of Compliance is issued on a voluntary basis for electrical equipment below the voltage limits of Radio Equipment Directive (RED) 2014/53/EU. The essential requirements are fulfilled accordingly based on the technical specifications applicable at the time of issuance.



This Certificate of Conformity is based on single evaluation of the submitted sample(s) of the above mentioned product. It does not imply an assessment of the whole product and relevant Directives to be observed.

☎ +86-400 000 9970 📠 +86-755-22336688 ✉ zkt@zkt-lab.com 🌐 www.zkt-lab.com

CERTIFICATE OF CONFORMITY

The following products have been tested by us and found in conformity with the (RoHS) Directive 2011/65/EU Annex II amending Directive (EU)2015/863. It is possible to use CE marking to demonstrate the conformity with this Directive.

Report No. : XNO251021001CX2-1
Applicant : YA LI ELECTRIC CO LTD
Address : Room 801, Building 9, No. 6, Yuyuan 4th Road, Huangjiang Town, DONGGUAN Guangdong 523000
Sample Name: : Furniture power distribution unit
Model No.: : YL-SKCE-909A
Sub-Model No.: : YL-SKCE-901, YL-SKCE-901A, YL-SKCE-902, YL-SKCE-902A, YL-SKCE-903, YL-SKCE-903A, YL-SKCE-905, YL-SKCE-905A, YL-SKCE-905C, YL-SKCE-906, YL-SKCE-906A, YL-SKCE-907, YL-SKCE-907A, YL-SKCE-908, YL-SKCE-908A, YL-SKCE-909
Manufacturer : YA LI ELECTRIC CO LTD
Manufacturer Address : Room 801, Building 9, No. 6, Yuyuan 4th Road, Huangjiang Town, DONGGUAN Guangdong 523000
Test method : IEC 62321-3-1:2013 & IEC 62321-5:2013 & IEC 62321-4:2013+A1:2017 & IEC 62321-7-1:2015 & IEC 62321-7-2:2017 & IEC 62321-6:2015 & IEC 62321-8:2017



For

Signature :

Technical supervisor

Signed for and on behalf of

Guangzhou Supreme Technology & Testing Service Co., LTD

21-Oct-2025



This certification is part of the full test report(s) and should be read in conjunction with it. The certificate is based on a single evaluation of one sample of above-mentioned products. It does not imply an assessment of the whole production and does not permit the use of the test lab logo.

Guangzhou Supreme Technology & Testing Service Co., LTD

103, NanSha IT Park, South Tower, No.2 Huanshi Dadao Nan, NanSha District, GuangZhou City, GuangDong Province.China

Tel: 020-39004143

Fax: 020-39390517

Email: service@xnotesting.com

Website: <http://www.xnotesting.com>



Product Service

Attestation of Conformity

No. N8A 129388 0002 Rev. 00

Holder of Attestation: Dongguan Yali Electric Appliance Co., Ltd.

8/F, Building 9, No. 6, Yuyuan 4th Road
Yuyuan Industrial Zone, Huangjiang Town
523750 Dongguan City, Guangdong Province
PEOPLE'S REPUBLIC OF CHINA

Product: Socket-outlets

This Attestation of Conformity is issued on a voluntary basis according to the Low Voltage Directive 2014/35/EU relating to electrical equipment designed for use within certain voltage limits. It confirms that the listed equipment complies with the principal protection requirements of the directive and is based on the technical specifications applicable at the time of issuance. It refers only to the particular sample submitted for conformity assessment. For details see: www.tuvsud.com/ps-cert

Test report no.: 6810024020601

Date, 2024-12-04

(Michael Xu)

Page 1 of 2

This Attestation does not replace the regulatory EU Declaration of Conformity (DoC) and does not allow for CE marking. After preparation of the necessary documentation and establishing compliance to requirements of all applicable directives, the manufacturer may sign a DoC and apply the CE marking. The DoC is issued under the sole responsibility of the manufacturer.

TÜV SÜD Product Service GmbH • Ridlerstraße 65 • 80339 Munich • Germany

TÜV®



Product Service

Attestation of Conformity

No. N8A 129388 0002 Rev. 00

Model(s):

YL-SKCE-901, YL-SKCE-901A, YL-SKCE-901A-PD20W,
YL-SKCE-902, YL-SKCE-902A, YL-SKCE-902A-PD20W,
YL-SKCE-903, YL-SKCE-903A, YL-SKCE-903A-PD20W,
YL-SKCE-905, YL-SKCE-905A, YL-SKCE-905A-PD20W,
YL-SKCE-906, YL-SKCE-906A, YL-SKCE-906A-PD20W,
YL-SKCE-907, YL-SKCE-907A, YL-SKCE-907A-PD20W,
YL-SKCE-908, YL-SKCE-908A, YL-SKCE-908A-PD20W,
YL-SKCE-909, YL-SKCE-909A, YL-SKCE-909A-PD20W

Parameters:

Rated voltage: 250Vac
Rated frequency: 50/60Hz
Rated current: 16A
Protection class: I
Degree of protection: IP20
Type of cable: H05VV-F 3G1.5mm²

**Tested
according to:**

DIN VDE 0620-1:2021
DIN VDE 0620-2-1:2021/A1:2023

Page 2 of 2

This Attestation does not replace the regulatory EU Declaration of Conformity (DoC) and does not allow for CE marking. After preparation of the necessary documentation and establishing compliance to requirements of all applicable directives, the manufacturer may sign a DoC and apply the CE marking. The DoC is issued under the sole responsibility of the manufacturer.

TÜV SÜD Product Service GmbH • Ridlerstraße 65 • 80339 Munich • Germany

TÜV®

Importeur	Decobus Handel GmbH
Adresse	Innungsstraße 9,21244 Buchholz, Deutschland
Email/URL	https://www.decobusgroup.de
Hersteller	Dongguan Yali Electric Appliance co.,Ltd
Adresse	8 /F,Building 9, No. 6, Yuyuan 4th Road, Yuyuan Industrial Zone,Huangjiang Town, Dongguan city, Guangdong Province
Email/URL	38053076@qq.com
Partienummer	20251225-08
Hergestellt in	CHINA
	Decobus Handel GmbH Innungsstraße 9,21244 Buchholz,Deutschland https://www.decobusgroup.de



Produkt:Strip power supply
 Modell:YL-SKCE-902A
 Nennspannung:16A 250V AC, 50/60Hz
 Nennfrequenz:USB-A 5V 2.1A TYPE-C
 5V 2.1A
 Leistung:10.5W



FR
Pensez à donner ou recycler.

 Association
  Magasin
  Déchèterie

<https://quefairedemesdechets.fr>



FR
Cet appareil, ses cordons, et batterie se recyclent

À DÉPOSER EN MAGASIN
 
 OU
 
 À DÉPOSER EN DÉCHÈTERIE

Points de collecte sur www.quefairedemesdechets.fr
 Privilégiez la réparation ou le don de votre appareil !