

Installation sanleitung Installation Instruction Instruction d'installation

SKU:N634P433681

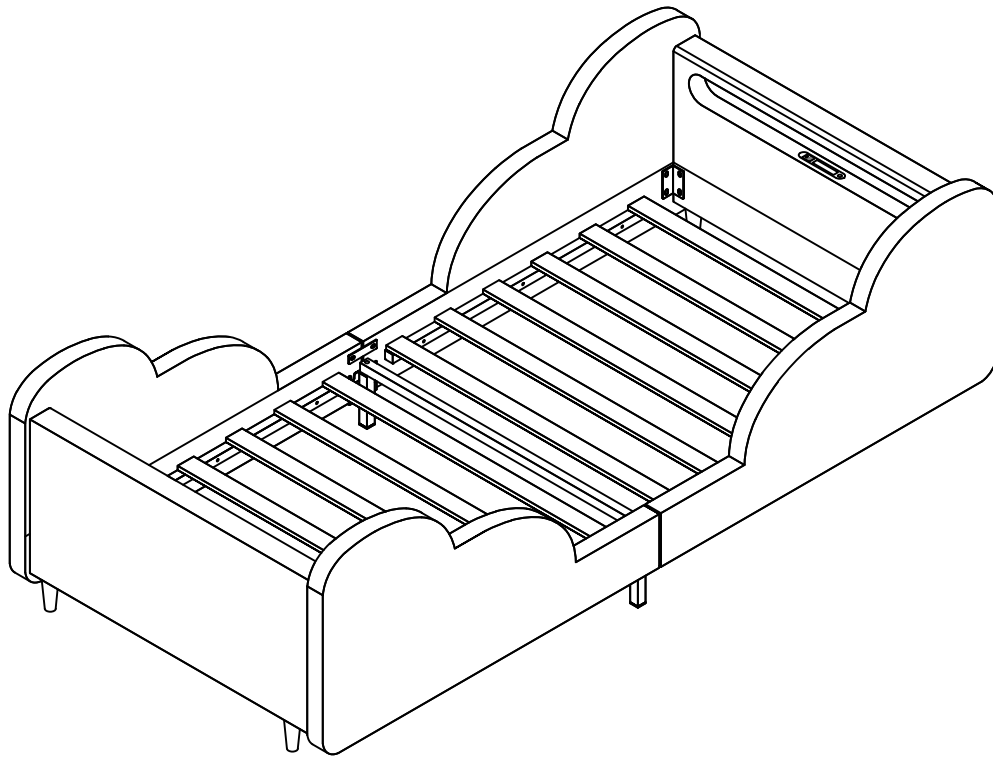

English

IMPORTANT ! KEEP FOR FUTURE REFERENCE : READ CAREFULLY

- To be assembled by an adult. Assembly must be checked by an adult before use
- WARNING ! Keep all screws, small parts and plastic bags out of the reach of children
- Properly identify all parts before assembling
- Never use your item if any of its parts are broken or missing
- Should any problems arise, please contact our After Sales Service
- Manufacturer's instructions shall be followed at all times
- Care: Clean with a soft, dry cloth. In case of larger stains, carefully rub with a slightly damp, non-abrasive sponge
- Avoid the risk of fire by not placing furniture near sources of ignition or hot items
- Do not jump on the bed

Deutsch

WICHTIG ! ZUM SPÄTEREN NACHSCHLAGEN AUFBEWAHREN: SORGFÄLTIG LESEN

- Muss von einem Erwachsenen zusammengebaut werden. Der Zusammenbau muss vor dem Gebrauch von einem Erwachsenen überprüft werden
- WARNUNG! Bewahren Sie alle Schrauben, Kleinteile und Plastikbeutel außerhalb der Reichweite von Kindern auf
- Kennzeichnen Sie vor dem Zusammenbau alle Teile richtig
- Benutzen Sie Ihren Artikel niemals, wenn Teile gebrochen sind oder fehlen
- Sollten Probleme auftreten, wenden Sie sich bitte an unseren Kundendienst
- Die Anweisungen des Herstellers sind stets zu befolgen
- Pflege: Mit einem weichen, trockenen Tuch reinigen. Bei größeren Flecken vorsichtig mit einem leicht feuchten, nicht scheuernden Schwamm abreiben. nicht scheuernden Schwamm
- Vermeiden Sie die Gefahr eines Brandes, indem Sie die Möbel nicht in der Nähe von Zündquellen oder heißen Gegenständen aufstellen
- Nicht auf das Bett springen

Français

IMPORTANT ! CONSERVER POUR RÉFÉRENCE ULTÉRIEURE : LIRE ATTENTIVEMENT

- Le montage doit être effectué par un adulte. Le montage doit être vérifié par un adulte avant Utilisation
- ATTENTION ! Tenir les vis, les petites pièces et les sachets en plastique hors de portée des enfants
- Identifiez correctement toutes les pièces avant de les assembler
- N'utilisez jamais votre article si l'une de ses pièces est cassée ou manquante
- En cas de problème, veuillez contacter notre service après-vente
- Les instructions du fabricant doivent être respectées à tout moment
- Entretien : nettoyer avec un chiffon doux et sec. En cas de taches plus importantes, frotter soigneusement avec une éponge non abrasive légèrement humide. légèrement humide et non Abrasive
- Évitez les risques d'incendie en ne plaçant pas les meubles à proximité de sources d'inflammation ou d'objets chauds
- Ne pas sauter sur le lit

Italiano

IMPORTANTE! CONSERVARE PER RIFERIMENTO FUTURO: LEGGERE ATTENTAMENTE

- Deve essere assemblato da un adulto. L'assemblaggio deve essere controllato da un adulto prima dell'uso
- **ATTENZIONE!** Tenere tutte le viti, le piccole parti e i sacchetti di plastica fuori dalla portata dei bambini
- Identificare correttamente tutte le parti prima dell'assemblaggio
- Non utilizzare mai l'articolo se alcune parti sono rotte o mancanti
- In caso di problemi, si prega di contattare il nostro Servizio Post Vendita
- Le istruzioni del produttore devono essere sempre seguite
- Cura: Pulire con un panno morbido e asciutto. In caso di macchie più estese, strofinare accuratamente con una spugna leggermente umida e nonspugna leggermente umida e non abrasiva
- Evitare il rischio di incendio, non collocando i mobili vicino a fonti di accensione o a oggetti caldi
- Non saltare sul letto

Español

¡ IMPORTANTE ! CONSERVELO PARA FUTURAS CONSULTAS: LEA ATENTAMENTE

- Debe ser montado por un adulto. El montaje debe ser comprobado por un adulto antes del uso
- ADVERTENCIA** Mantenga todos los tornillos, piezas pequeñas y bolsas de plástico fuera del alcance de los niños.
- Identifique correctamente todas las piezas antes de montarlas
 - Nunca utilice su artículo si alguna de sus piezas está rota o falta
 - Si surge algún problema, póngase en contacto con nuestro Servicio Postventa
 - Las instrucciones del fabricante deben seguirse en todo momento
 - Cuidado: Limpiar con un paño suave y seco. En caso de manchas más grandes, frote cuidadosamente con una esponja no abrasiva ligeramente humedecida.
 - Evite el riesgo de incendio no colocando los muebles cerca de fuentes de ignición u objetos calientes.
 - No saltar sobre la cama.

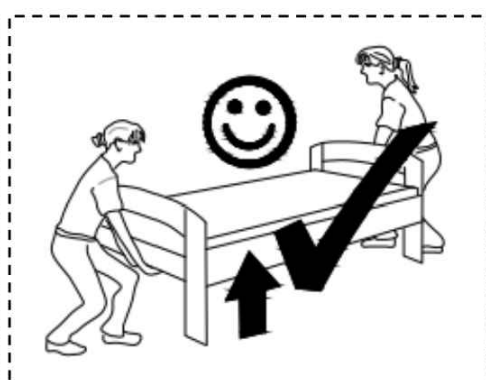
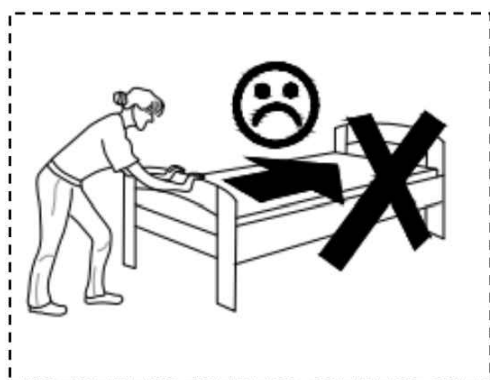



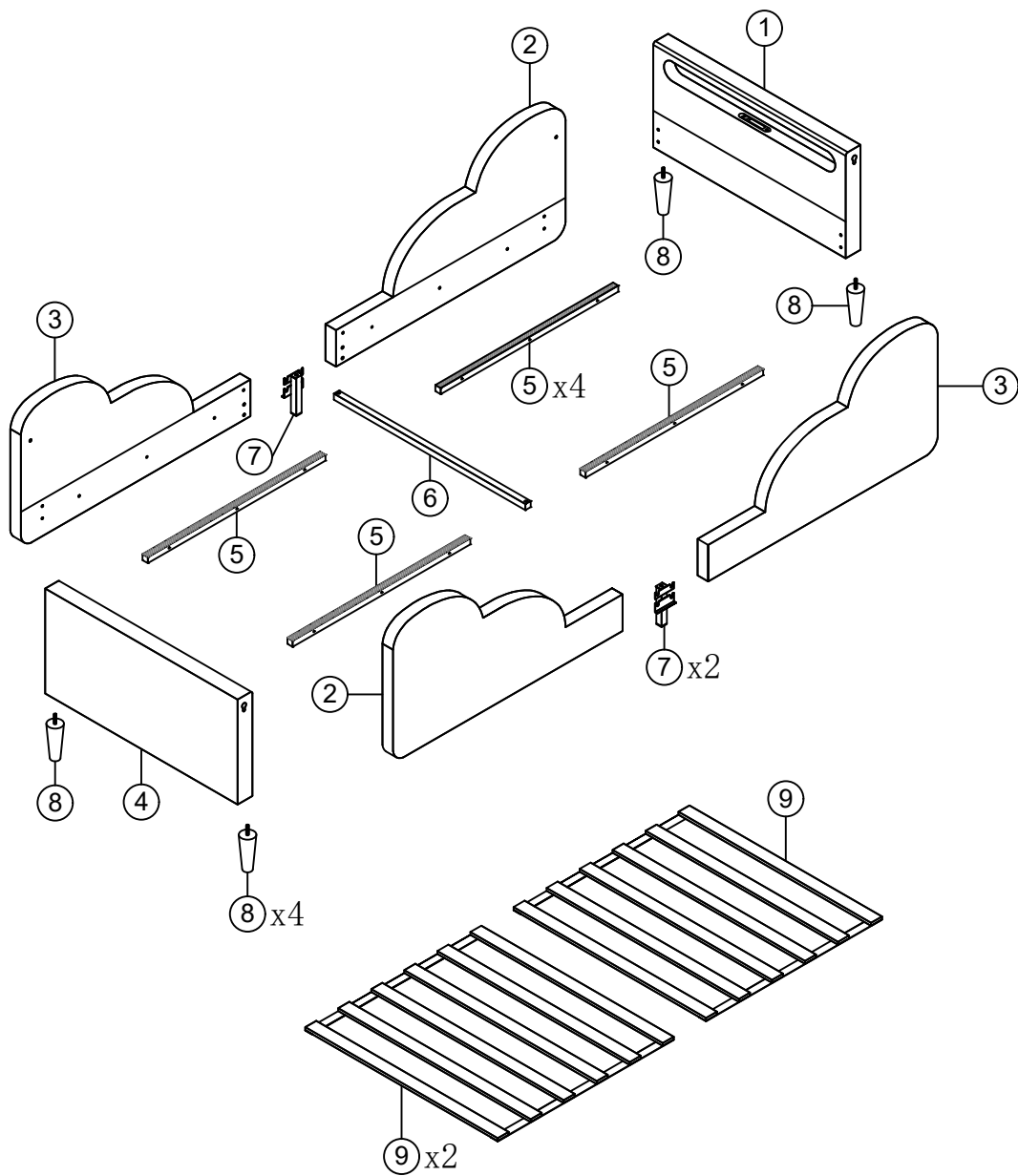

Stückliste



Part List

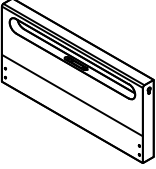
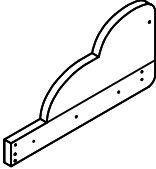
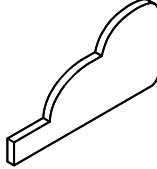
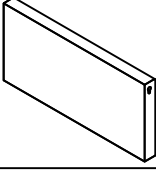

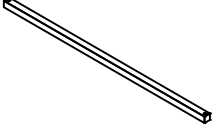

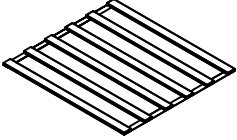

(Liste der Einzelteile)

N634P433681

<p>① x1</p> 	<p>② x2</p> 	<p>③ x2</p> 
<p>Head board (Kopfbrett)</p>	<p>Side rail (Seitige Schiene)</p>	<p>Side rail (Seitige Schiene)</p>
<p>④ x1</p> 	<p>⑤ x4</p> 	<p>⑥ x1</p> 
<p>Foot board (Bodenbrett)</p>	<p>Side rails support bar (Seitliche Stützstange)</p>	<p>Cross bar (Kreuzstange)</p>
<p>⑦ x2</p> 	<p>⑧ x4</p> 	<p>⑨ x2</p> 
<p>Side rails Support legs (Seitenschiene – Stützbeine)</p>	<p>Bed legs (Bettknöchel)</p>	<p>Slats (Lattes)</p>

Hardware list (Hardwareliste)

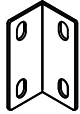
N634P433681

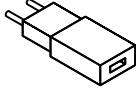
<p>Ax1</p> 	<p>Bx28</p>  <p>M8x18mm</p>	<p>Cx14</p>  <p>M8x40mm</p>
<p>Allen Key (Inbusschlüssel)</p>	<p>Bolts (Schrauben)</p>	<p>Bolts (Schrauben)</p>
<p>Dx2</p> 	<p>Ex4</p> 	<p>Fx4</p> 
<p>Two hole iron (Zweihöhlen-Eisen)</p>	<p>"7" Connector ("7"-Stecker)</p>	<p>Twist gasket (Drehverbindungsichtung)</p>
<p>Gx4</p>  <p>M8x30mm</p>	<p>Hx1</p> 	
<p>Bolts (Schrauben)</p>	<p>Power adapter (Stromadapter)</p>	

DE: Vor dem Einbau die Schrauben in die Löcher stecken und festziehen, aber nicht bis 100%, 70% bis 80% anziehen reicht aus. Schließlich, nachdem alle Schrauben installiert sind, ziehen Sie alle Schrauben auf 100%.

Wenn Sie auf diese Probleme stoßen, wie z. B. Fehlausrichtung der Löcher oder Unfähigkeit, bestimmte Teile zu installieren, überprüfen Sie bitte, ob die Schrauben korrekt verwendet werden und passen Sie die Dichtigkeit der Schrauben an.

UK: Before installation, insert the screws into the holes and tighten them, but do not tighten them to 100%, 70% to 80% is sufficient. Finally, after all screws are installed, tighten all screws to 100%.

If you encounter these issues, such as if the holes cannot be aligned or some parts cannot be installed, please check if the screws are used correctly and adjust the tightness of the screws.

FR: Insérer la vis dans le trou avant la fin de l'assemblage, serrer la vis, mais ne pas serrer à 100%, 70% ~ 80% est correct. Enfin, une fois que toutes les vis sont bien serrées, toutes les vis sont serrées à 100%.

Si vous rencontrez ces problèmes, par exemple si les trous ne sont pas alignés ou si certaines pièces ne peuvent pas être montées, vérifiez que les vis sont utilisées correctement et Ajustez leur serrage.

Attention: Do not tighten the screws before completing the entire installation. If you have any difficulty with the installation process, please feel free to contact us.

(Achtung: Ziehen Sie die Schrauben erst fest, wenn die gesamte Installation abgeschlossen ist. Wenn Sie beim Installationsvorgang Schwierigkeiten haben, können Sie sich gerne an uns wenden.)

Step 1:

Fix the Bed legs (8) to the Head board (1) and Foot board (4) with Twist gasket F.

(Befestigen Sie die Bettbahnen (8) am Kopfbrett (1) und am Fußbett (4) mit dem Twist-Gasket F.)

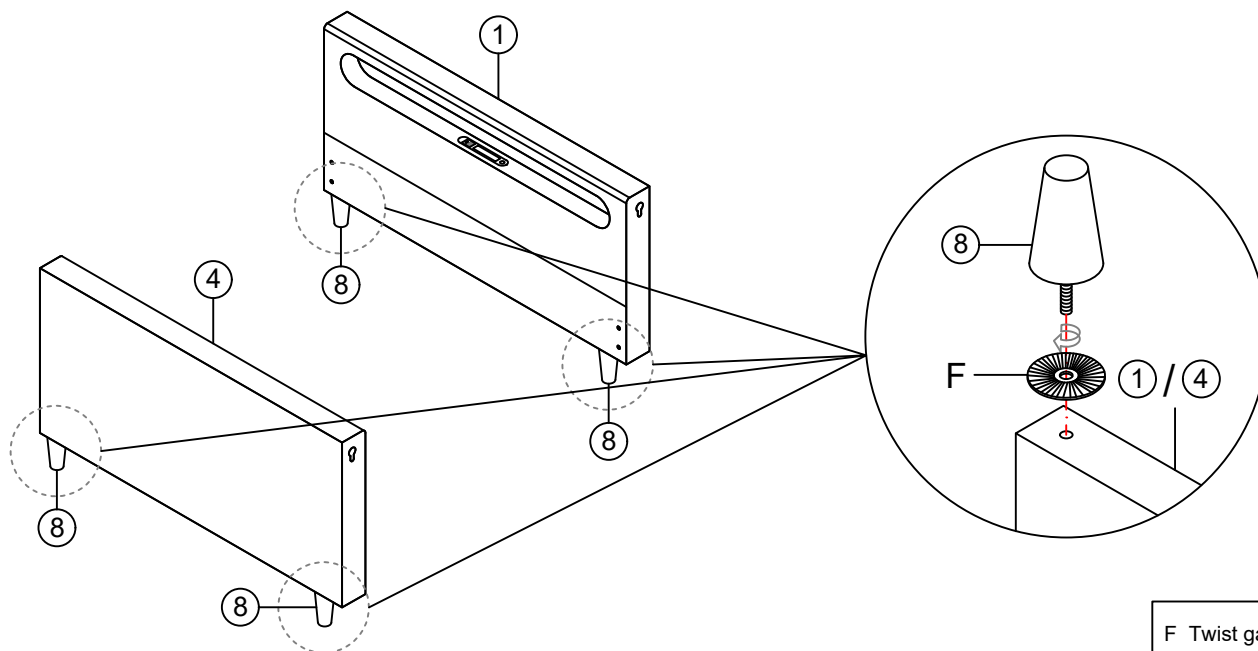

F Twist gasket x 4



Step 2:

Fix the Side rails Support legs (7) to the Side rail (2) and (3) with Bolts B by using Allen key A.

(Befestigen Sie die Stützbeine (7) der Seitenbalken (2) und (3) mit den Bolzen B mithilfe des Allen-Schlüssels A.)

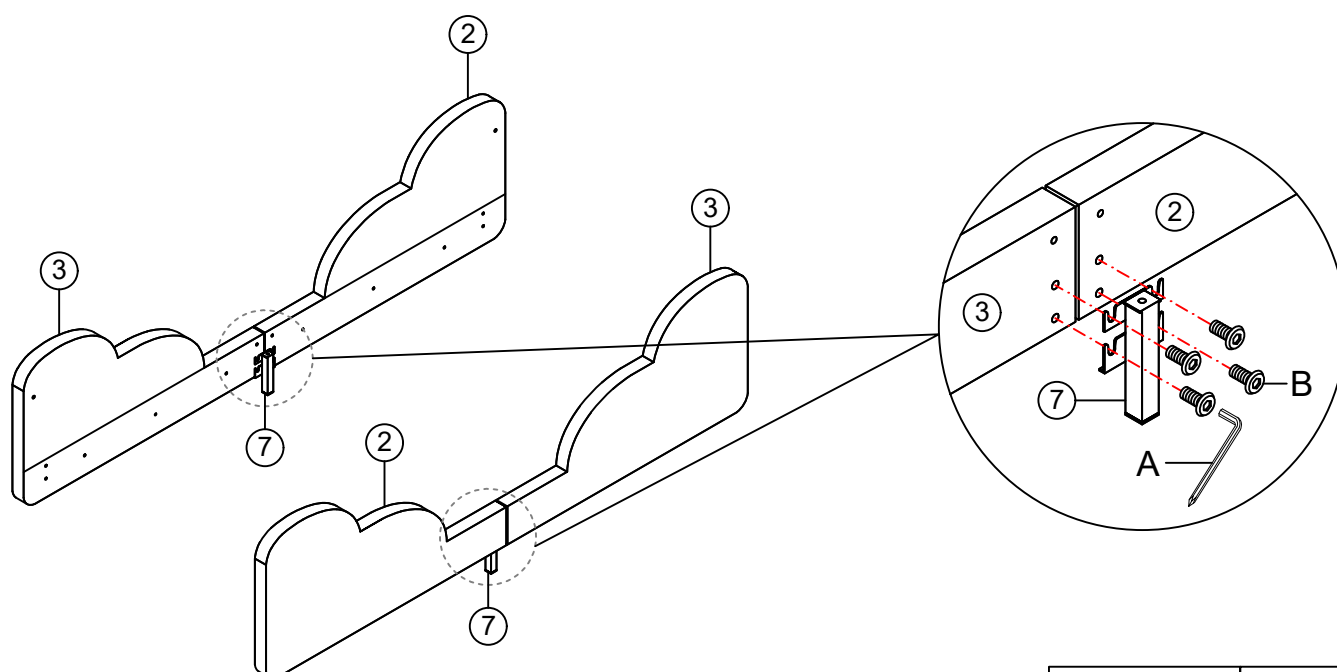

A Allen Key



B Bolts x 8



M8x18mm

Step 3:

Fix the Two hole iron D to the Side rail ② and ③ with Bolts B by using Allen key A.

(Befestigen Sie den Eisenstift mit zwei Löchern D mit den Bolzen B an den Seitenstangen ② und ③ mithilfe des Allen-Schlüssels A.)

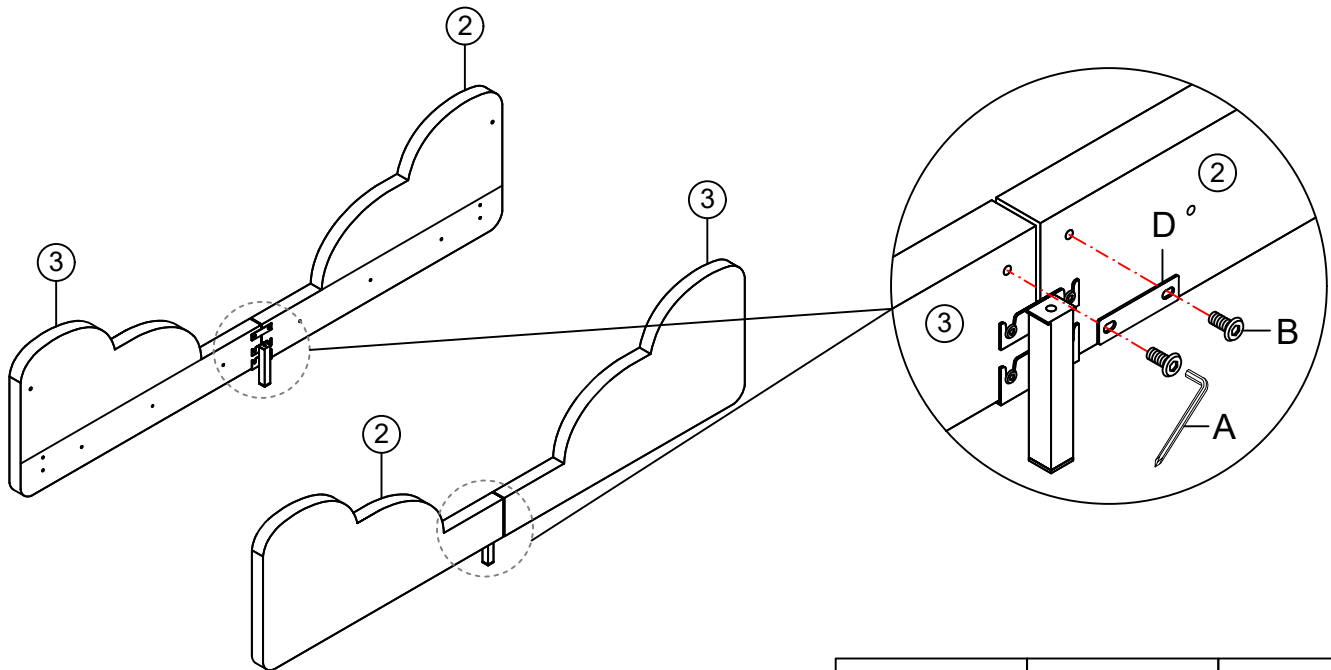

A Allen Key



B Bolts x 4



M8x18mm

D Two hole iron x 2



Step 4x2:

Fix the Bolts G to the Side rail ② and ③ by using Allen key A .

It is normal for a part of the screw to leak outside when you tighten it.

(Befestigen Sie die Bolzen G am Seitenrahmen ② und ③ mit dem Allenkey A. Es ist normal, dass beim Anziehen ein Teil des Schraubens nach außen leckt.)

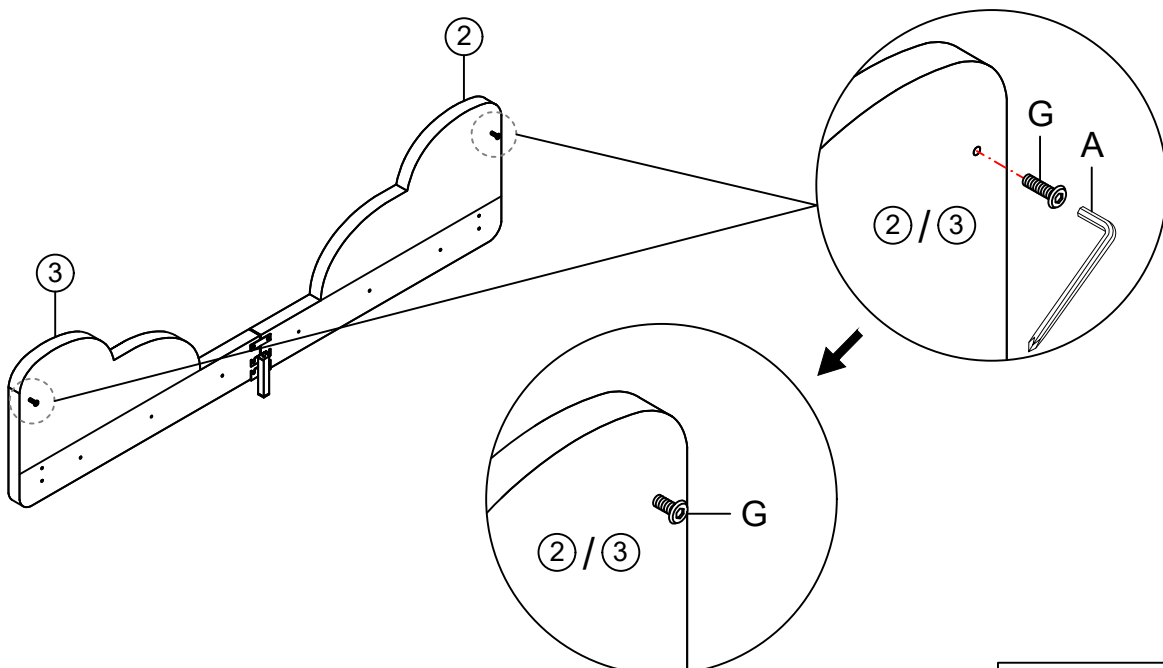

A Allen Key



G Bolts x 4



M8x30mm

Step 5:

Please insert the screw G on the Side rail into the water droplet shaped holes at the Headboard and foot board, then contact the Headboard, Footboard and Siderail together.

(Stecken Sie den Schraub G der Seitenbalken in die wassertröpfchenförmigen Öffnungen am Kopfbrett und am Fußbrett und verbinden Sie anschließend Kopfbrett, Fußbrett und Seitenbalken miteinander.)

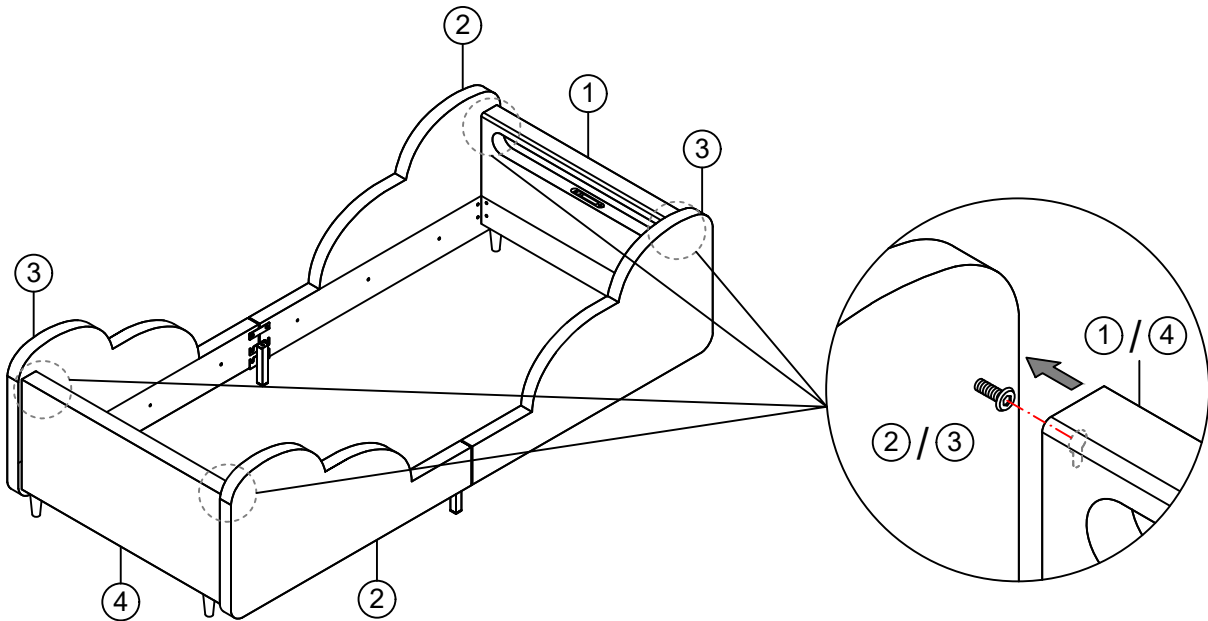

Step 6:

Fix the Head board (1) and Foot board (4) to the Side rail (2) and (3) with Bolts B and "7" Connector E by using Allen key A.

(Befestigen Sie die Kopfplatte (1) und Fußplatte (4) an den Seitenbalken (2) und (3) mit den Bolzen B sowie dem "7"-Stecker E mithilfe des Allen-Schlüssels A.)

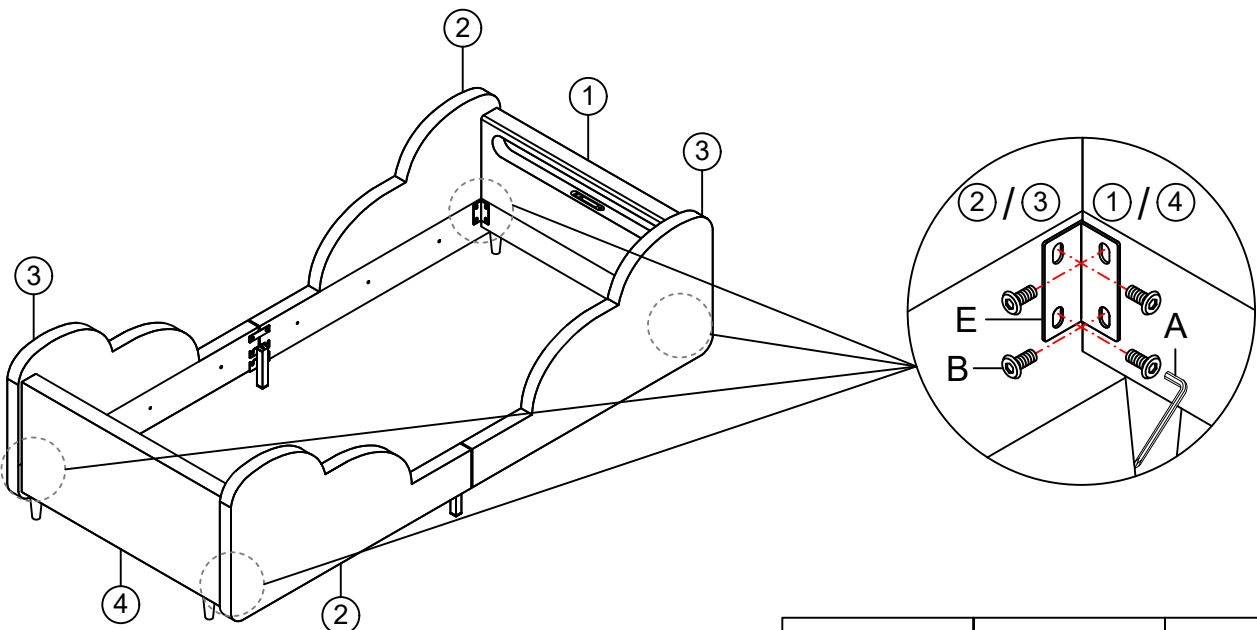

A Allen Key



B Bolts x 16



M8x18mm

E "7" Connector x 4



Step 7:

Fix the Side rails support bar (5) to the Side rail (2) and (3) with Bolts C by using Allen key A.

(Befestigen Sie die Seitenbalkenstützstange (5) mit den Bolzen C an den Seitenbalken (2) und (3) mithilfe des Allen-Schlüssels A.)

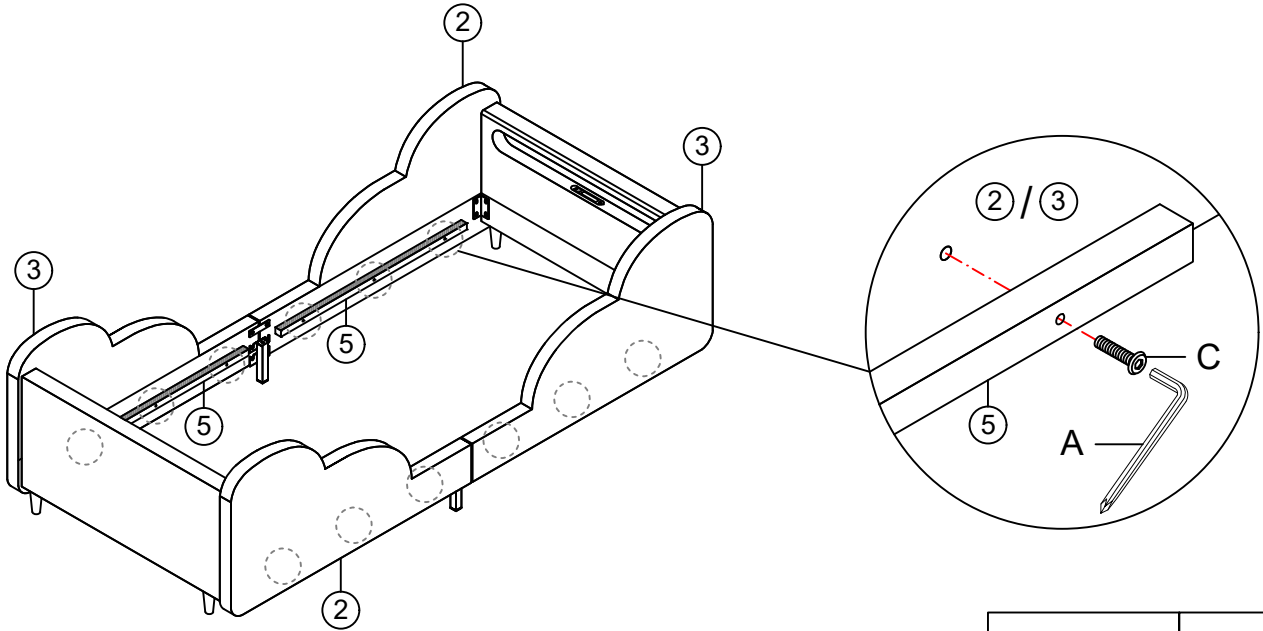

A Allen Key



C Bolts x 12



M8x40mm

Step 8:

Fix the Cross bar (6) to the Side rails Support legs (7) with Bolts C by using Allen key A.

(Befestigen Sie die Kreuzstange (6) mit den Bolzen C an den Seitenbalkenstützbeinen (7) mithilfe des Allen-Schlüssels A.)

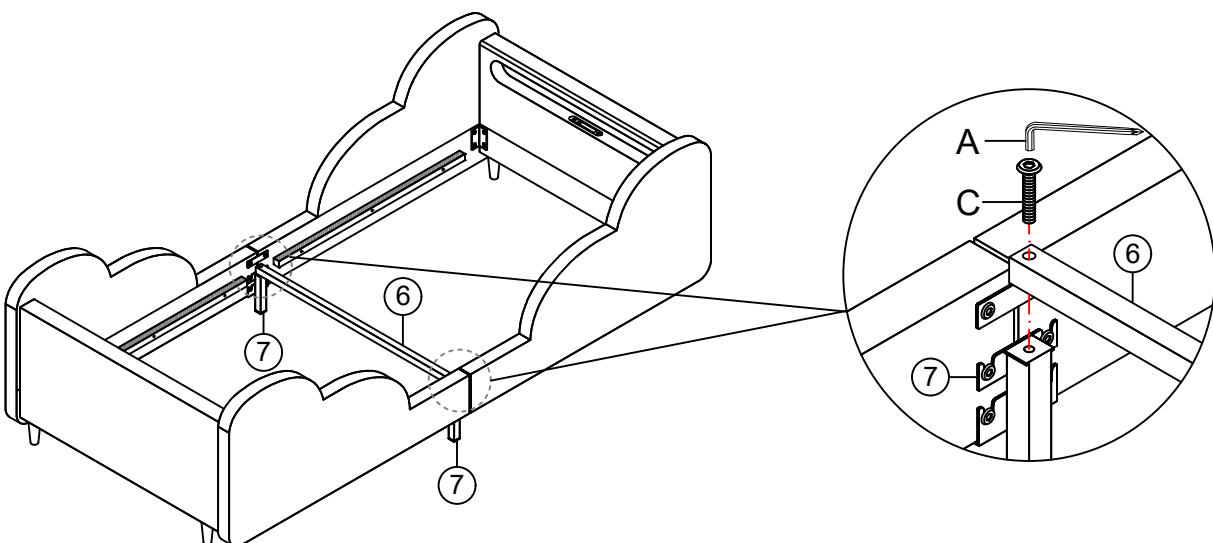

A Allen Key



C Bolts x 2



M8x40mm

Step 9:

Fix the Slats ⑨ to the Side rails support bar ⑤.

(Befestigen Sie die Schienen ⑨ an die Seitenstange ⑤.)

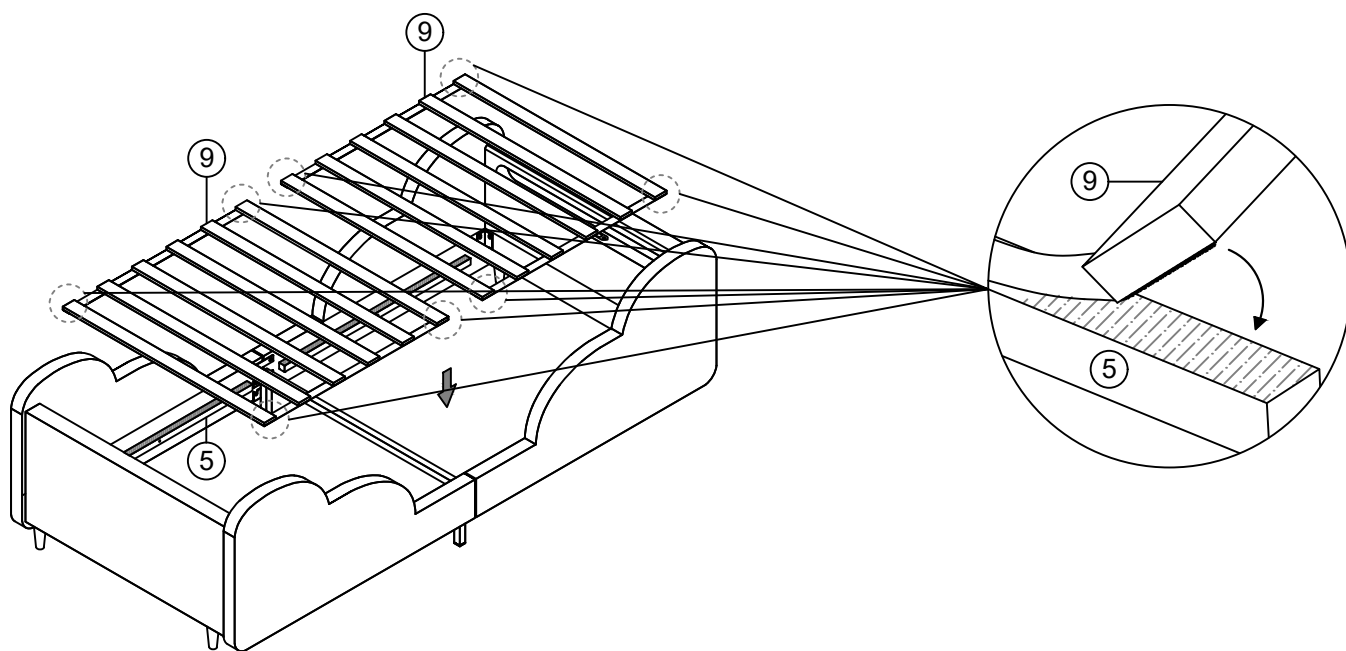

Step 10:

Fix the USB end to the Power adapter H.

(Befestigen Sie das USB-Ende am Stromadapter H.)

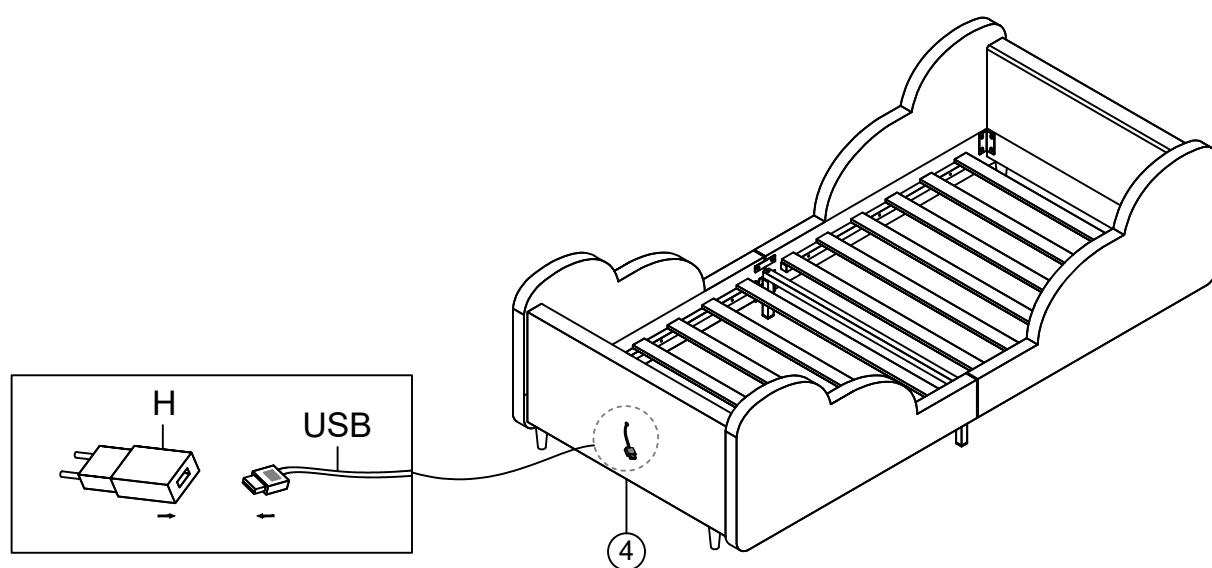

H Power adapter x 1



Step 11:

Every thing is finished now, please enjoy your bed.
(Jetzt ist alles vorbei, bitte genießen Sie Ihr Bett.)

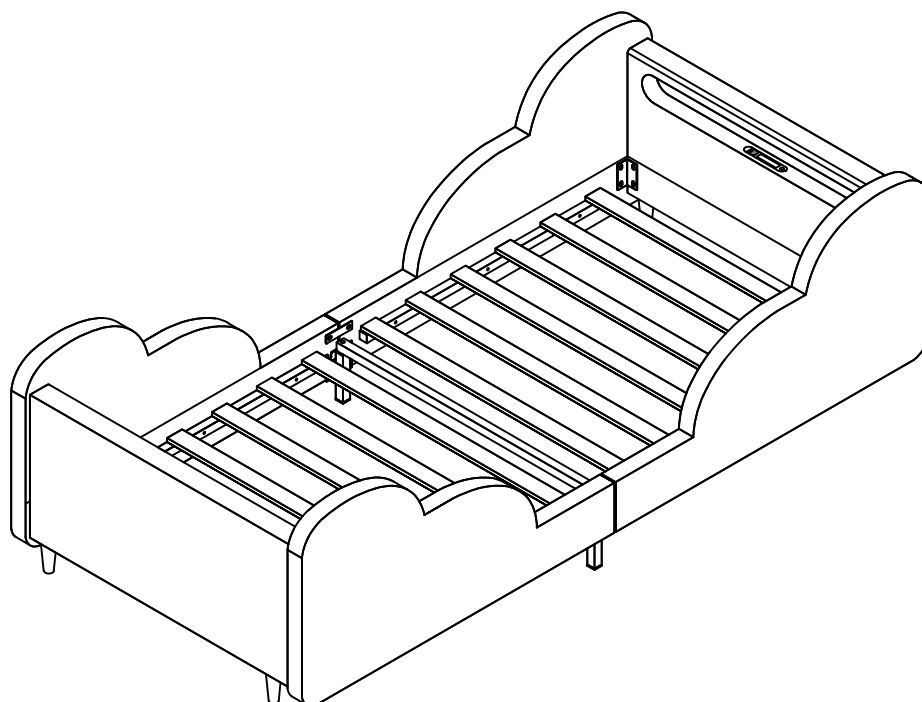

Certificate No. : HUAX251126401KC



Certificate of Conformity

Certificate's Holder : Lufeng Jiazi Town Hongyu Furniture Accessories Factory

Address : No. 20, Pengxing Nei Road, Lujia Avenue, Jiazi Town, Lufeng City, Guangdong Province

Manufacturer : Lufeng Jiazi Town Hongyu Furniture Accessories Factory

Address : No. 20, Pengxing Nei Road, Lujia Avenue, Jiazi Town, Lufeng City, Guangdong Province

Product Name : Nightstand, sofa USB

Product Model (S) : HY-1011, HY-1012, HY-1013

Trade Mark : N/A

Related Standard(s) : IEC62321-3-1:2013, IEC62321-5:2013, IEC62321-4: 2017, IEC62321-7-1:2015, IEC 62321-7-2:2017, IEC 62321-6:2015, IEC 62321-8:2017

Report No. : HUAX251126401KR

The product described above has been consolidated by us and found in compliance with the council RoHS 2.0 Directive (EU) 2015/863 and (EU)2017/2102 amending Annex II to Directive 2011/65/EU. It is only valid in connection with the test report



Kevin Su

Dec. 01, 2025

Certification Manager

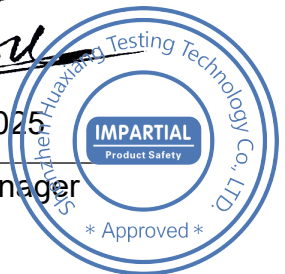

Shenzhen Huaxiang Testing Co., Ltd

1st Floor, Building A1, No. 2082 Jincheng Road, Shajing Street, Bao'an District, Shenzhen City, Guangdong Province, China

Web.: [Http:// www.hua-x.com](http://www.hua-x.com)

E-mail: huaxiang@hua-x.com Tel.: +86-0755-23010432



Certificate No. : HUAX240826001KC

huaxiang

Certificate of Conformity

Certificate's Holder : Lufeng Jiazi Town Hongyu Furniture Accessories Factory**Address** : No. 20, Pengxing Nei Road, Lujia Avenue, Jiazi Town, Lufeng City, Guangdong Province**Manufacturer** : Lufeng Jiazi Town Hongyu Furniture Accessories Factory**Address** : No. 20, Pengxing Nei Road, Lujia Avenue, Jiazi Town, Lufeng City, Guangdong Province**Product Name** : Bedside USB night light**Product Model (S)** : HY-1011**Trade Mark** : N/A**Related Standard(s)** : EN IEC 55015: 2019+A11:2020
EN 61547: 2009.**Report No.** : HUAX240826001KR

The EUT described above has been tested by us with the listed standards and found in compliance with the council EMC Directive 2014/30/EU. It is possible to use CE marking to demonstrate the compliance with this EMC Directive



Certification Manager

Shenzhen Huaxiang Testing Co., Ltd201, Building A10, Fuhai Information Port, Xinhe Community,
Fuhai Street, Bao'an District, Shenzhen City, Guangdong
Province, China

Web.:Http:// www.hua-x.com

E-mail: huaxiang@hua-x.com Tel.:+86-0755-23010432





Certificate NO.: LBTC230314130R

Certificate of Compliance

EU- Restriction of the use of certain hazardous substances (RoHS) -

Report No. : LBTR230314130R

Applicant : Shengdi (Jieyang) Electronic Technology Co., Ltd.

Address : Middle Section of Zhenghe Road, Paotai, Rongcheng District, Guangdong, China

Manufacturer : Shengdi (Jieyang) Electronic Technology Co., Ltd.

Address : Middle Section of Zhenghe Road, Paotai, Rongcheng District, Guangdong, China

Product : Power Adapter

Model No. : CT-11, CTC-11, CCT-11, CTF-11, CTR-11, CT-21, CTC-21, CTR-21.

Trade Mark : N/A

Test Standards	IEC 62321-3-1:2013
	IEC 62321-5:2013
	IEC 62321-4:2013+AMD1:2017
	IEC 62321-7-1:2015
	IEC 62321-7-2:2017
	IEC 62321-6:2015

The test results based on the above specified products comply with the EU RoHS 2 Directive 2011/65 / EU Appendix II Amendment Directive (EU) 2015/863 as last amended by Directive (EU) 2017/2102 limit requirements.

The test results apply only to the particular sample tested and to the specific tests carried out. Specifically to the sample investigated in our test reference number only. Other relevant Directives have to be observed.



Date of Issue: Mar. 14, 2023

This statement is based on a single evaluation of the sample(s) of above mentioned product. It does not imply an assessment of the whole production.

SHENZHEN LABTEST TECHNOLOGY LABORATORY LTD.
901-12, Block 1, No.9 Jinxiu Middle Road, Laokeng Community, Longtian
Street, Pingshan District, Shenzhen, Guangdong, China. www.clabtest.com



Declaration of Conformity

Applicant : Shengdi (Jieyang) Electronic Technology Co., Ltd.
Middle Section of Zhenghe Road, Paotai, Rongcheng District,
Guangdong, China

Manufacturer : Shengdi (Jieyang) Electronic Technology Co., Ltd.
Middle Section of Zhenghe Road, Paotai, Rongcheng District,
Guangdong, China

Product Name : Power Adapter

Trade Name : N/A

Main Test Model : CT-11

Additional Model : CTC-11, CCT-11, CTF-11, CTR-11, CT-21, CTC-21, CTR-21.

Test Report No. : LBTR230314130E

Test Standards	EN55032:2015/A11:2020
	EN IEC 61000-3-2:2019+A1:2021
	EN 61000-3-3:2013+A1:2019+A2:2021
	EN55035:2017/A11:2020

The EUT described above has been tested by us with the listed standards and found in compliance with the council EMC directive 2014/30/EU. It is possible to use CE marking to demonstrate the compliance with this EMC Directive.

The Declaration applies to the tested sample above mentioned only and shall not imply an assessment of the whole production.



Declaration of Conformity

Applicant : Shengdi (Jieyang) Electronic Technology Co., Ltd.
Middle Section of Zhenghe Road, Paotai, Rongcheng District,
Guangdong, China

Manufacturer : Shengdi (Jieyang) Electronic Technology Co., Ltd.
Middle Section of Zhenghe Road, Paotai, Rongcheng District,
Guangdong, China

Product Name : Power Adapter

Trade Name : N/A

Main Test Model : CT-11

Additional Model : CTC-11, CCT-11, CTF-11, CTR-11, CT-21, CTC-21, CTR-21.

Test Report No. : LBTR230314130S

Test Standards	EN 62368-1:2014+A11:2017
----------------	--------------------------

The EUT described above has been tested by us with the listed standards and found in compliance with the council LVD directive 2014/35/EU. It is possible to use CE marking to demonstrate the compliance with this LVD Directive.



The Declaration applies to the tested sample above mentioned only and shall not imply an assessment of the whole production.



Chief Manager

Date of Issue Mar. 14, 2023



Importeur	Decobus Handel GmbH
Adresse	Innungsstraße 9, 21244 Buchholz, Deutschland
Email/URL	https://www.decobusgroup.de
Hersteller	Lufeng Jiazi Town Hongyu Furniture Accessories Factory
Adresse	No. 20, Pengxing Nei Road, Lujia Avenue, Jiazi Town, Lufeng City, Guangdong Province
Email/URL	https://114034846@gg.com
Partienummer	HY-1011
Hergestellt in	China
 	Decobus Handel GmbH Innungsstraße 9, 21244 Buchholz, Deutschland www.decobusgroup.de



Product Name: Bedside USB night light
 Model: HY-1011
 Rated voltage: DC5V
 Power: 10W

Importeur	Decobus Handel GmbH
Adresse	Innungsstraße 9, 21244 Buchholz, Deutschland
Email/URL	https://www.decobusgroup.de
Hersteller	Shengdi(Jieyang) Electronic Technology Co., LTD
Adresse	Middie Section of Zhenghe Road, Rongcheng District, Guangdong, China
Email/URL	114034846@qq.com
Partienummer	CT-11
Hergestellt in	China
	Decobus Handel GmbH Innungsstraße 9, 21244 Buchholz, Deutschland www.decobusgroup.de



Product Name: Power Adapter
 Model: CT-11
 Rated voltage: DC5V
 Rated frequency: 50-60HZ
 Power: 10W



FR
 Cet appareil, ses accessoires, cordons et batteries se recyclent

À DÉPOSER EN MAGASIN  OU  À DÉPOSER EN DÉCHÈTERIE

Points de collecte sur www.quefairedemesdechets.fr
 Privilégiez la réparation ou le don de votre appareil !