

DE: Installationsanleitung  
EN: installation instructions  
FR: Instructions d'installation  
IT: Istruzioni per l'installazione  
ES: Instrucciones de instalación

SKU NUMBER:N625P421021/N625P421022/N625P421023

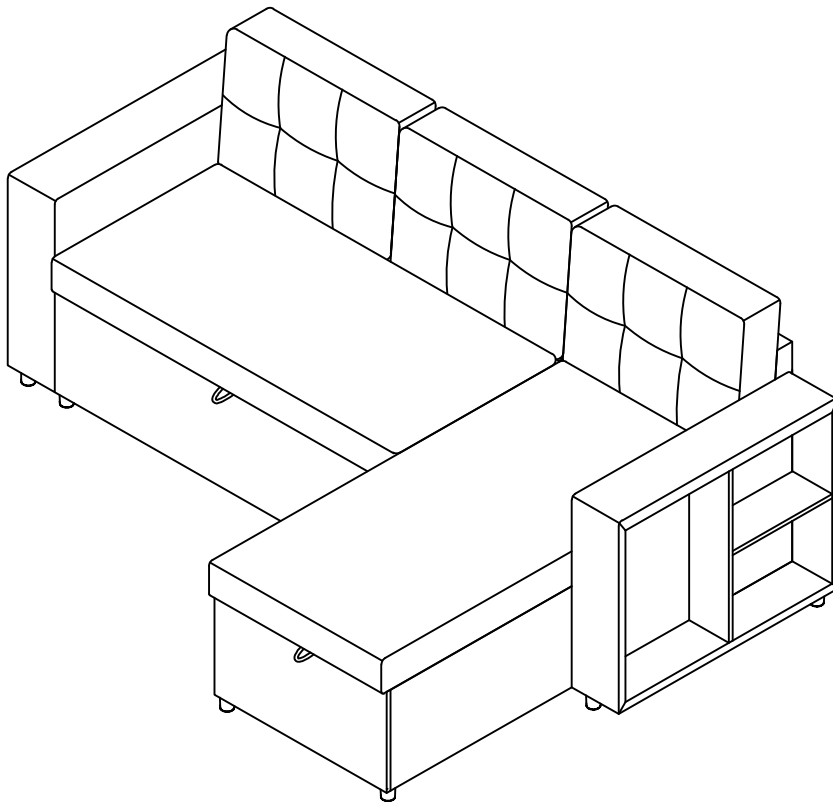

DE: Unsere Produkte werden in drei Pakete verteilt geliefert. Die Lieferzeit der drei Pakete kann unterschiedlich sein. Bitte haben Sie Geduld. Vielen Dank für Ihr Verständnis!

EN: Our products will be delivered in three packages. The delivery times for these three packages may vary. Please be patient and wait. Thank you for your understanding!

FR: Nos produits seront livrés en trois colis. Le délai de livraison pour ces trois colis peut différer. Veuillez patienter. Merci de votre compréhension !

IT: I nostri prodotti verranno spediti in tre pacchi separati. I tempi di consegna per i tre pacchi potrebbero essere diversi. Si prega di attendere con pazienza. Grazie per la comprensione!

ES: Nuestros productos se enviarán en tres paquetes diferentes, los cuales podrían llegar en momentos distintos. Por favor, tenga paciencia. ¡Gracias por su comprensión!

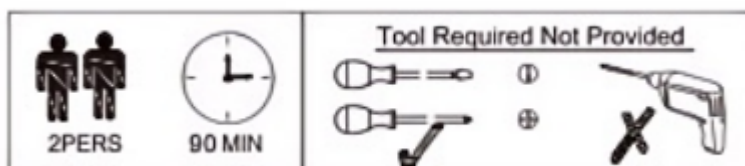



## [DE]

**Achtung:** Lesen Sie die Anleitung vor dem Zusammenbau bitte vollständig durch. Überprüfen Sie, ob Sie alle auf den Seiten aufgeführten Komponenten und Werkzeuge haben.

**Achtung:** Überprüfen Sie regelmäßig alle Beschläge und Befestigungen, um sicherzustellen, dass sie sicher sind und um Unfälle zu vermeiden.

**Achtung:** Stellen Sie Möbel nicht in die Nähe von Feuerquellen oder heißen Gegenständen, um Brandgefahr zu vermeiden.

**Achtung:** Erlauben Sie Kindern nicht, auf die Möbel zu klettern, da dies zum Umkippen und zu schweren Verletzungen führen kann. Bauen Sie die Möbel außerhalb der Reichweite von Kindern zusammen.

## [EN]

**Warning:** Please read instructions fully before starting assembly. Check you have all the components and tools listed on pages.

**Warning:** Regularly check all fittings and fastenings to ensure they are secure and to prevent accidents

**Warning:** Do not place furniture close to fire sources or high-temperature objects to avoid the risk of fire.

**Warning:** Do not allow children to climb on the furniture as this may result in tipping and serious personal injury. Assemble the furniture away from the reach of children.

## [FR]

**Avertissement:** Veuillez lire entièrement les instructions avant de commencer l'assemblage. Vérifiez que vous disposez de tous les composants et outils répertoriés sur les pages.

**Avertissement:** Vérifiez régulièrement tous les accessoires et fixations pour vous assurer qu'ils sont bien fixés et pour éviter les accidents

**Avertissement:** Ne placez pas les meubles à proximité de sources de feu ou d'objets à haute température pour éviter tout risque d'incendie.

**Avertissement:** Ne laissez pas les enfants grimper sur les meubles car cela pourrait entraîner un basculement et des blessures graves. Assemblez les meubles hors de portée des enfants.

## [IT]

**Attenzione:** leggere attentamente le istruzioni prima di iniziare il montaggio. Verificare di avere tutti i componenti e gli utensili elencati nelle pagine.

**Attenzione:** controllare regolarmente tutti i raccordi e gli elementi di fissaggio per assicurarsi che siano sicuri e prevenire incidenti

**Attenzione:** non posizionare i mobili vicino a fonti di fuoco o oggetti ad alta temperatura per evitare il rischio di incendio.

**Attenzione:** non consentire ai bambini di arrampicarsi sui mobili poiché ciò potrebbe causare ribaltamenti e gravi lesioni personali. Montare i mobili lontano dalla portata dei bambini.

## [ES]

**Advertencia:** Lea las instrucciones completamente antes de comenzar el montaje. Compruebe que tiene todos los componentes y herramientas que se enumeran en las páginas.

**Advertencia:** Compruebe periódicamente todos los accesorios y sujeciones para asegurarse de que estén seguros y evitar accidentes.

**Advertencia:** No coloque los muebles cerca de fuentes de fuego u objetos a alta temperatura para evitar el riesgo de incendio.

**Advertencia:** No permita que los niños se suban a los muebles, ya que esto puede provocar que vuelquen y lesiones personales graves. Monte los muebles fuera del alcance de los niños.



[DE]

**Warnung:** Die maximale Belastbarkeit dieses Möbels beträgt: 150 kg, bitte nicht überlasten!

[EN]

**Warning:** The maximum load-bearing capacity of this furniture is: 150 kg, please do not overload!

[FR]

**Avertissement:** La capacité de charge maximale de ce meuble est de : 150 kg, merci de ne pas surcharger !

[IT]

**Attenzione:** La capacità di carico massima di questo mobile è: 150 kg, non sovraccaricare!

[ES]

**Advertencia:** La capacidad máxima de carga de este mueble es: 150 kg, ¡no lo sobrecargue!

Importeur	Decobus Handel GmbH
Adresse	Innungsstraße 9, 21244 Buchholz, Deutschland
Email/URL	<a href="https://www.decobusgroup.de">https://www.decobusgroup.de</a>
Hersteller	Fujian Minghongsen Smart Home Co., Ltd.
Adresse	Factory Building 1, No. 6, Shengda East Road, Yanxi Town, Changtai District, Zhangzhou City, Fujian Province
Email/URL	<a href="mailto:zzxhxznjj@163.com">zzxhxznjj@163.com</a>
partienummer	N625P421021/ N625P421022/ N625P421023
Hersteller in	Hergestellt In china
	Decobus Handel GmbH Innungsstraße 9, 21244 Buchholz, Deutschland <a href="https://www.decobusgroup.de">https://www.decobusgroup.de</a>

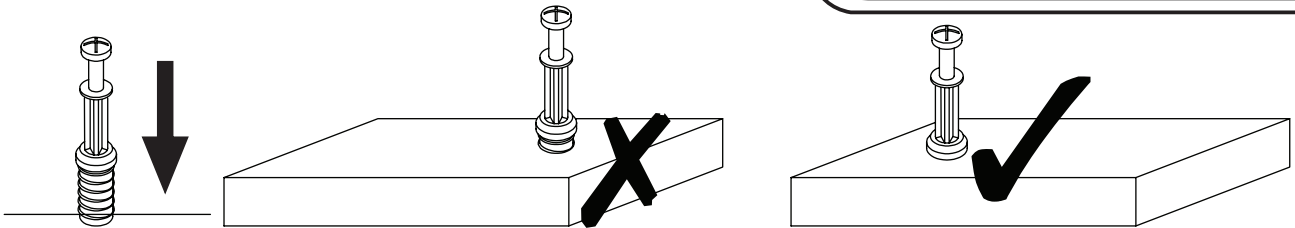

**EN\_QUICKFIT:** Tighten quickfit until shoulder is flush with panel. Do not overtighten or undertighten.

**FR\_RACCORD RAPIDE:** Faites serrer le raccord rapide jusqu'à ce que l'épaulement soit parfaitement encastré dans le panneau. Il ne faut ni trop serrer ni insuffisamment serrer.

**ES\_QUICKFIT:** Apriete quickfit hasta que el hombro se descargue con el panel. NO lo sobreapriete ni lo apriete poco.

**DE\_QUICKFIT:** Ziehen Sie den Quickfit fest, bis die Schulter mit der Platte bündig ist. Bitte nicht zu fest oder zu schwach anziehen.

**IT\_MONTAGGIO RAPIDO:** Stringere il montaggio rapido fino a quando la spalla è a filo con il pannello, non stringere troppo o troppo poco.

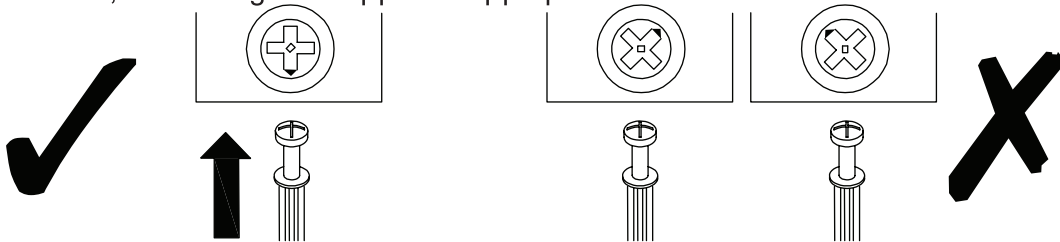

**EN\_CAM LOCK:** When fitting cam lock, ensure starting position is correct before you insert connecting quickfit.

**FR\_SERRURE BATTEUSE:** Avant d'insérer la serrure batteuse, veillez à la bonne orientation avant d'insérer le raccord rapide.

**ES\_CIERRE DE LA CÁMARA:** Cuando instale el cierre de la cámara, asegúrese de que la posición de inicio es correcta antes de que inserte el quickfit conector.

**DE\_CAM-LOCK:** Achten Sie bei der Montage des Cam-Locks auf die richtige Ausgangsposition, bevor Sie den Quickfit einsetzen.

**IT\_BLOCCAGGIO A CAMMA:** Quando si monta il bloccaggio a camma, assicurarsi che la posizione iniziale sia corretta prima di inserire il montaggio rapido di collegamento.

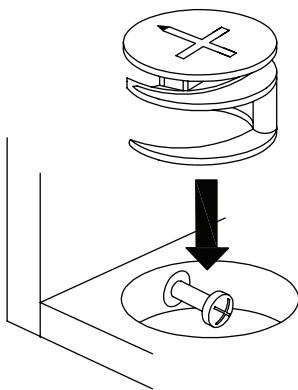

**EN\_Quickfit head** should be in the centre of the cam lock when the two panels are joined.

Cam lock should be inserted before quickfit.

**FR\_Lorsque** les deux panneaux sont assemblés, la tête du raccord rapide doit reposer au centre de la serrure batteuse. Il faut insérer la serrure batteuse avant le raccord rapide.

**ES\_El** cabezal del quickfit debe estar en el centro del cierre de la cámara cuando se unan los dos paneles.

Se debe insertar el cierre de la cámara antes que el quickfit.

**DE\_Der** Quickfit-Kopf sollte sich in der Mitte des Cam-Locks befinden, wenn die beiden Platten zusammengefügt sind.

Der Cam-Lock sollte vor dem Quickfit eingesetzt werden.

**IT\_La** testa del montaggio rapido deve trovarsi al centro del bloccaggio a camma quando i due pannelli sono uniti.

Il Bloccaggio a Camma deve essere inserito prima del montaggio rapido.

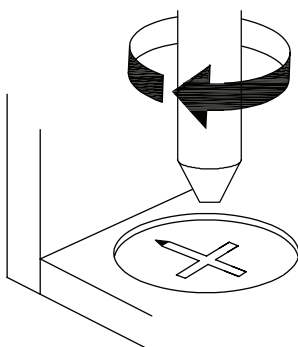

**EN\_Turn** cam lock clockwise to tighten.

**FR\_Faites** tourner la serrure batteuse dans le sens des aiguilles d'une montre pour la resserrer.

**ES\_Gire** el cierre de la cámara en sentido horario para apretarlo.

**DE\_Drehen** Sie den Cam-Lock im Uhrzeigersinn, um ihn festzuziehen.

**IT\_Ruotare** il bloccaggio a camma in senso orario per stringere.

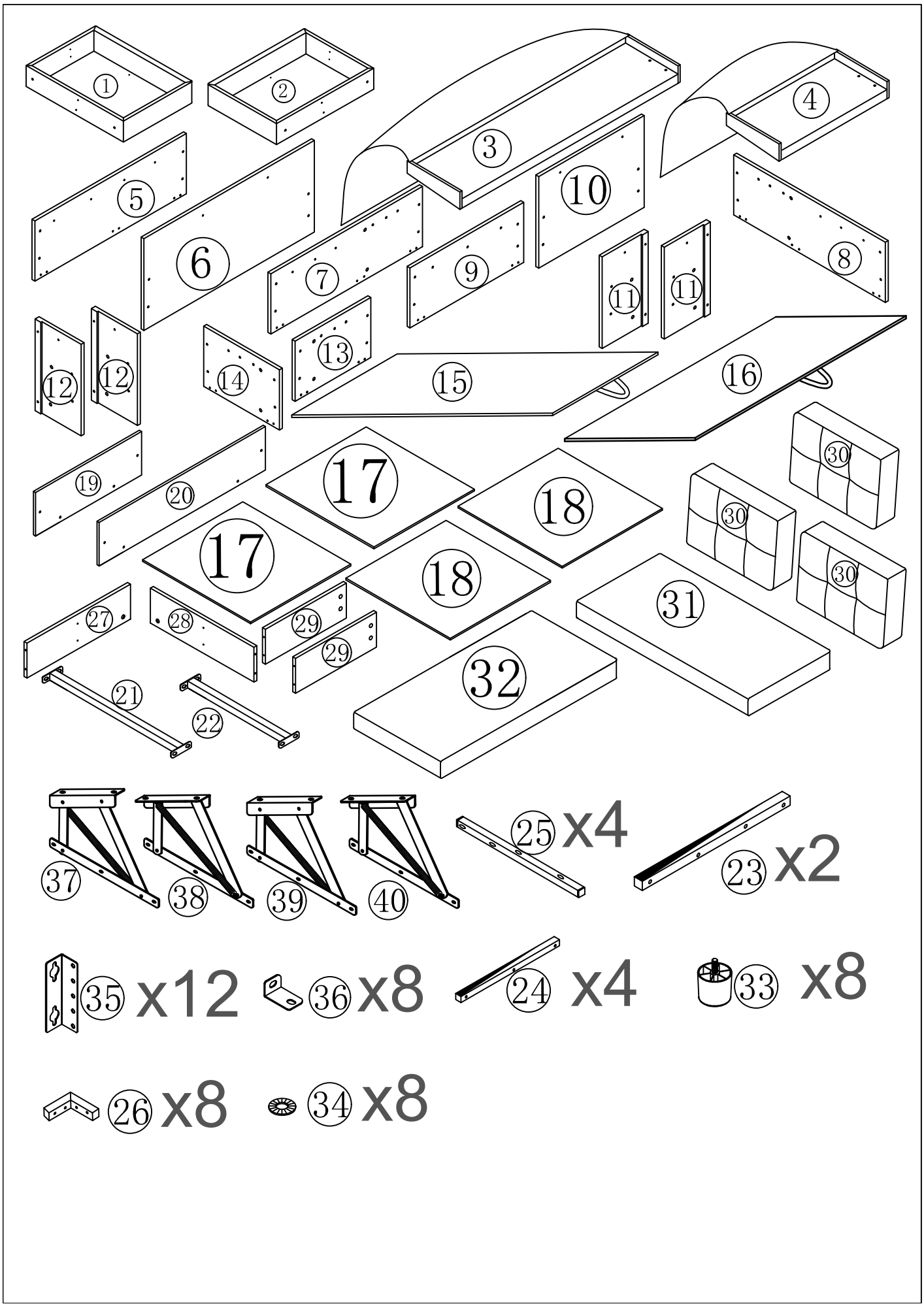

37 38 39 40 25 x4 23 x2

35 x12 36 x8 24 x4 33 x8

26 x8 34 x8





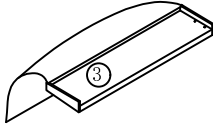
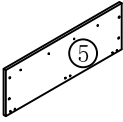
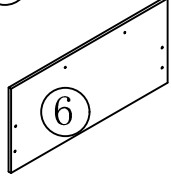
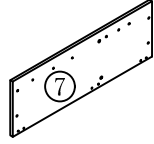
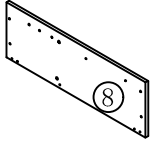
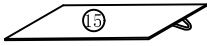
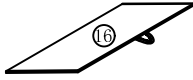
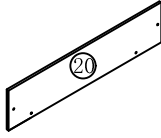
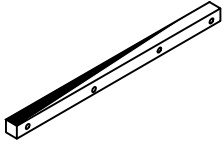

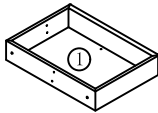
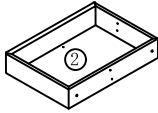
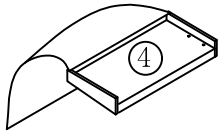
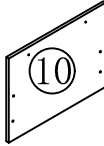
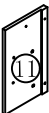

# TELLE

N625P421021

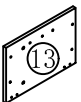
<p>③ x1</p> 	<p>⑤ x1</p> 	<p>⑥ x1</p> 	<p>⑦ x1</p> 
<p>⑧ x1</p> 	<p>⑮ x1</p> 	<p>⑯ x1</p> 	<p>⑳ x1</p> 
<p>㉓ x2</p> 			

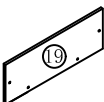

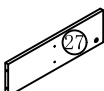





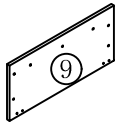
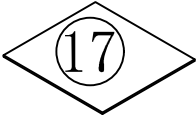
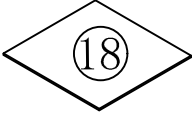
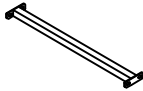
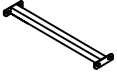

# TELLE

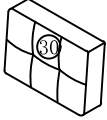
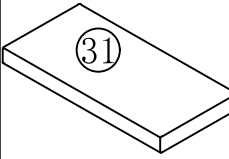
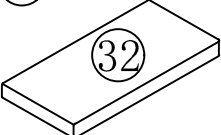
N625P421022

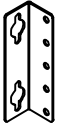
① x1 	② x1 	④ x1 	⑩ x1 
⑪ x2 	⑫ x2 	⑬ x1 	⑭ x1 
⑲ x1 	⑳ x4 	㉕ x4 	㉗ x1 
㉘ x1 	㉙ x2 		















# TELLE

N625P421022

⑨ x1 	⑰ x2 	⑱ x2 	⑳ x1 
㉒ x1 	㉔ x8 	㉖ x3 	㉗ x1 
㉘ x1 	㉙ x8 	㉚ x8 	㉛ x12 
㉜ x8 	㉝ x1 	㉞ x1 	㉟ x1 
㊱ x1 			

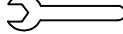
# TELLE

## Hardware List-Hardwareliste N625P421022



<p>A x72</p>  <p>M8*16</p>	<p>B x52</p>  <p>M8*37</p>	<p>C x28</p>  <p>M8*45</p>	<p>D x8</p>  <p>M6*12</p>
<p>E x12</p>  <p>M6*20</p>	<p>F x4</p>  <p>M8</p>	<p>G x32</p>  <p>Ø8×22 mm</p>	<p>H x8</p>  <p>M5×40 mm</p>
<p>I x6</p>  <p>40 mm</p>	<p>J x6</p>  <p>Ø15 mm</p>	<p>K x1</p>  <p>Letter Opener</p>	<p>L x1</p>  <p>M8 Spanner</p>
<p>M x1</p>  <p>S3</p>	<p>N x1</p>  <p>S4</p>	<p>O x1</p>  <p>S5</p>	

1

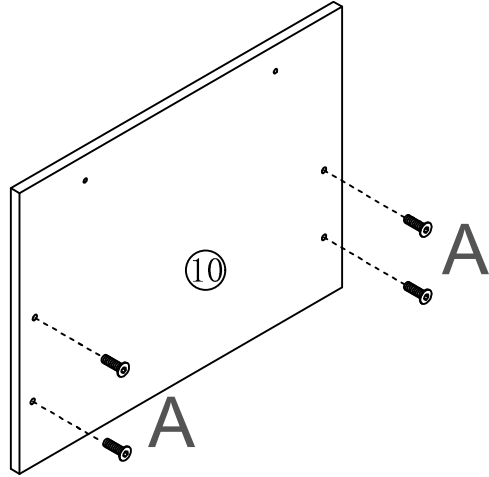
A M8\*16  
 X4



2

35  X4  
A M8\*16  X8

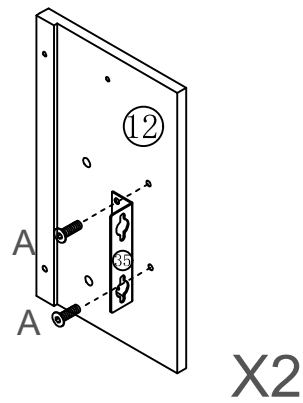
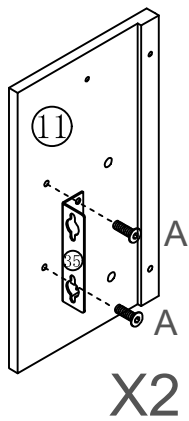

# 3

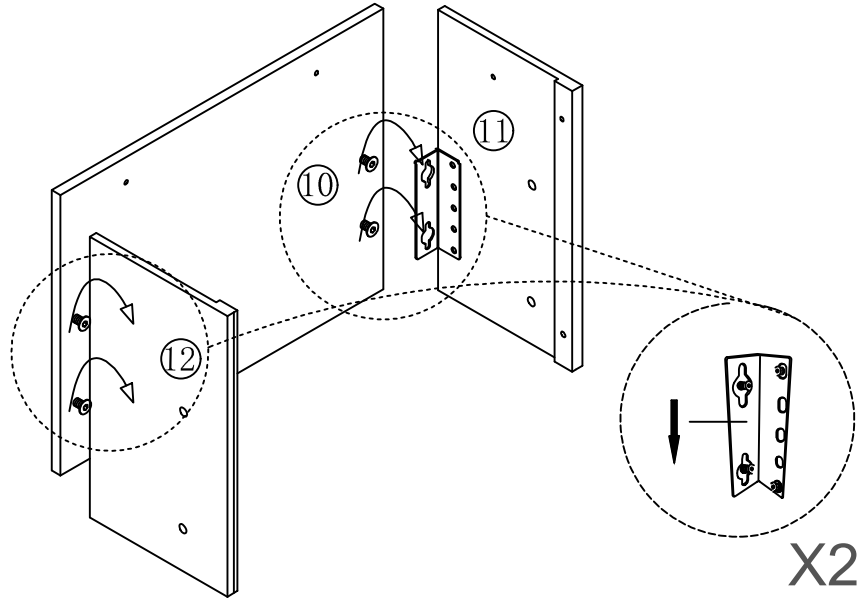

# 4

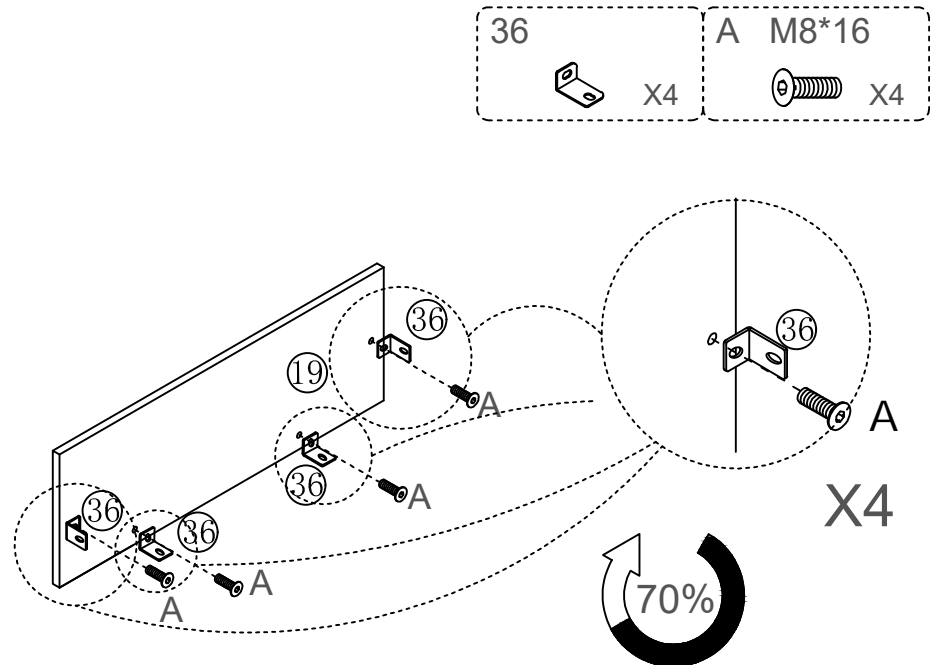

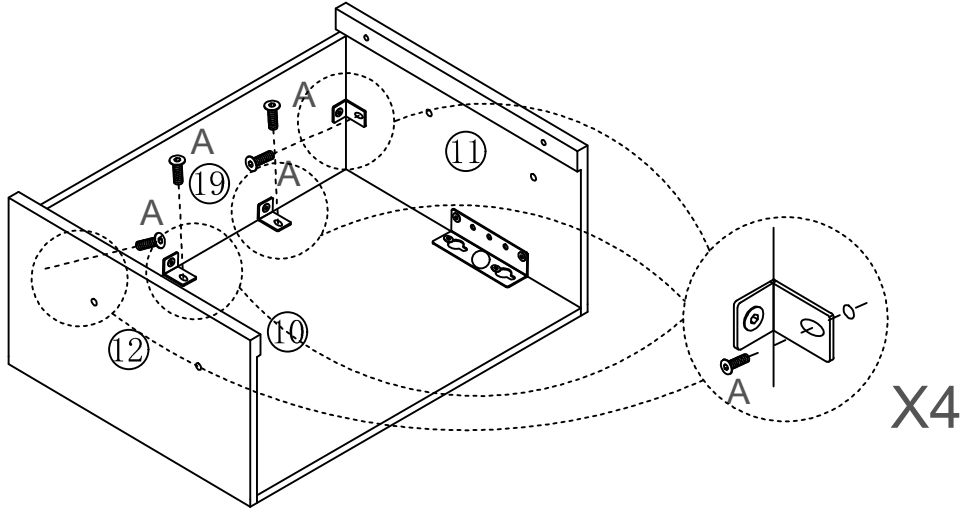

# 5

A M8\*16  
 X4



DE: Bitte alle Schrauben festziehen.  
EN: Please tighten all the screws.  
FR: Veuillez serrer tous les vis.  
IT: Per favore, stringete tutti i viti.  
ES: Por favor, apriete todos los tornillos.

# 6

G  X4  
C M8\*45  X4

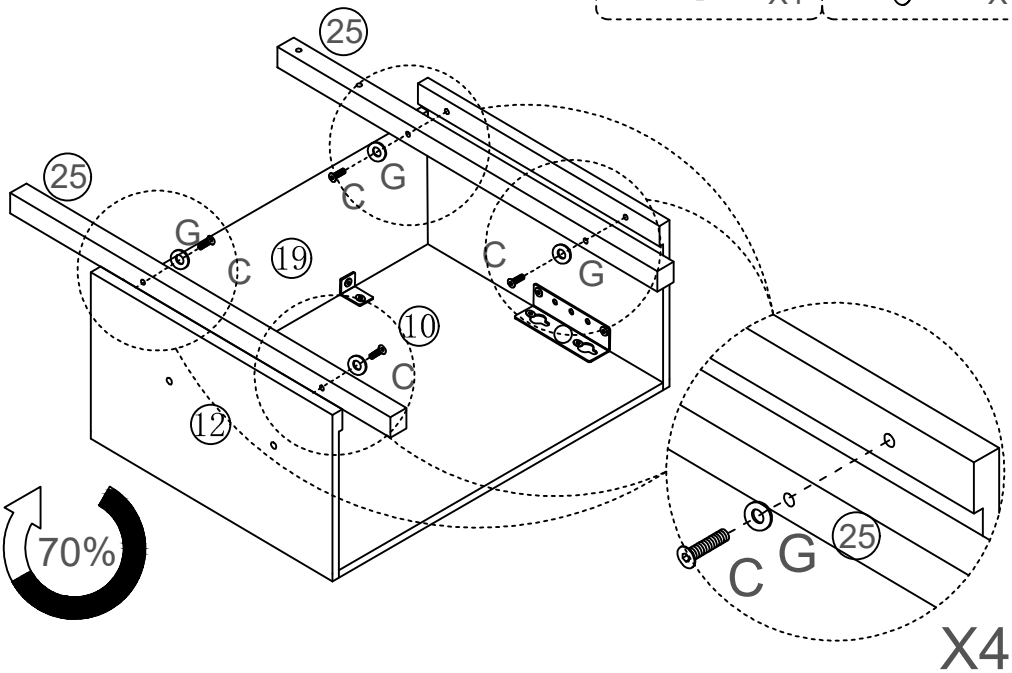

# 7

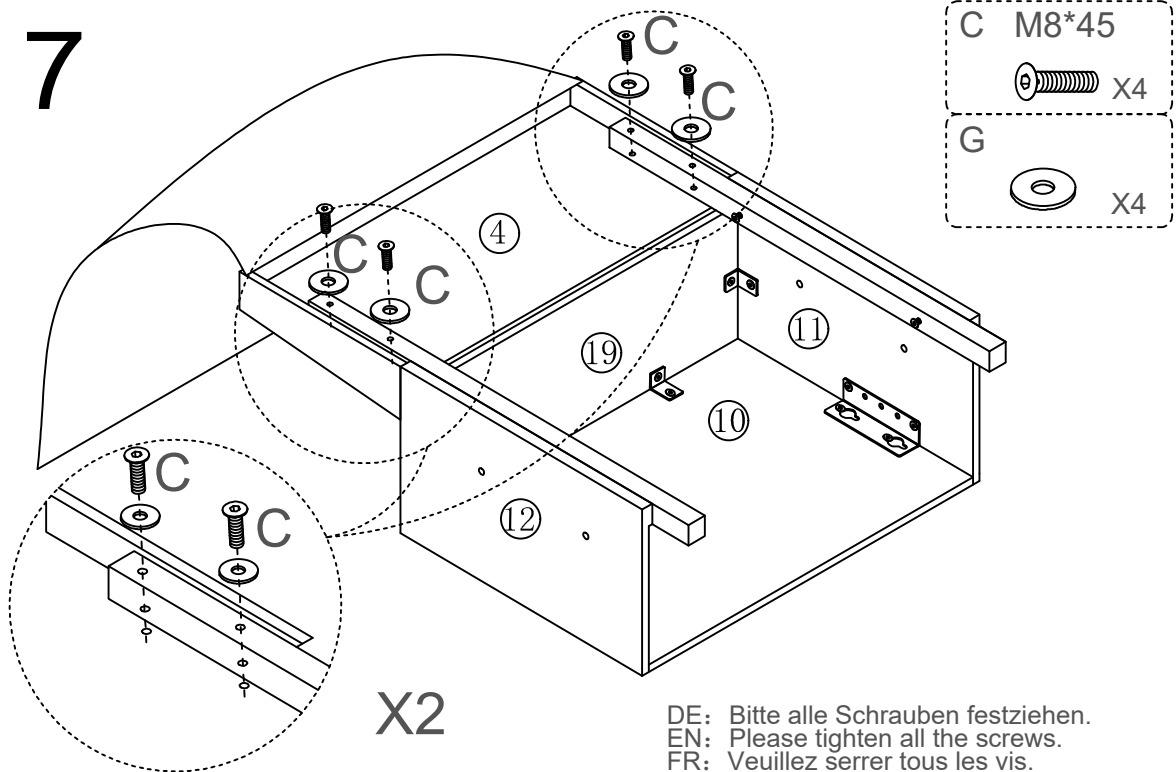

DE: Bitte alle Schrauben festziehen.  
EN: Please tighten all the screws.  
FR: Veuillez serrer tous les vis.  
IT: Per favore, stringete tutti i viti.  
ES: Por favor, apriete todos los tornillos.

# 8

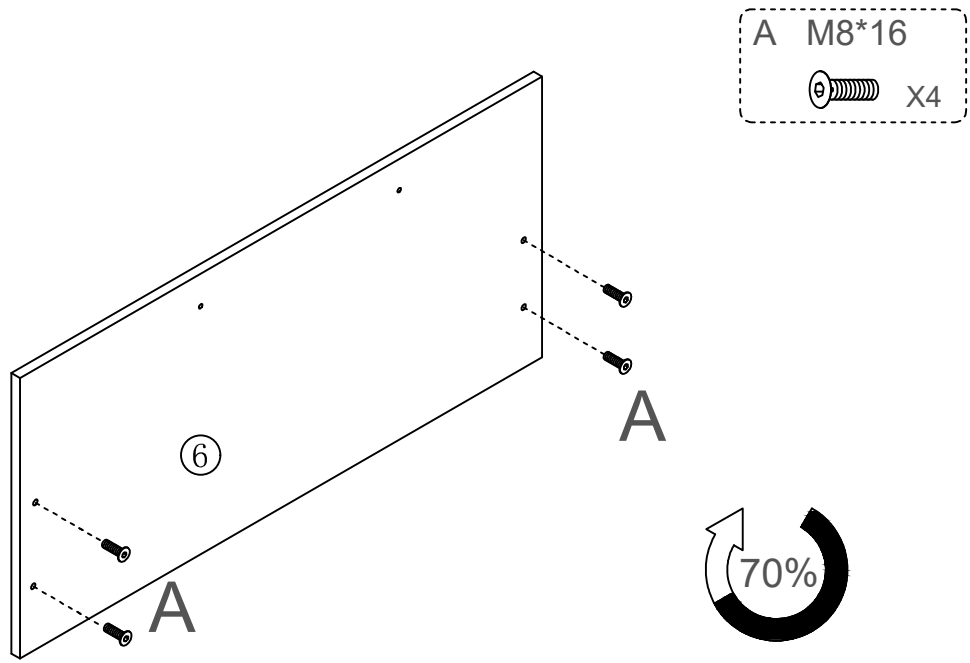

9

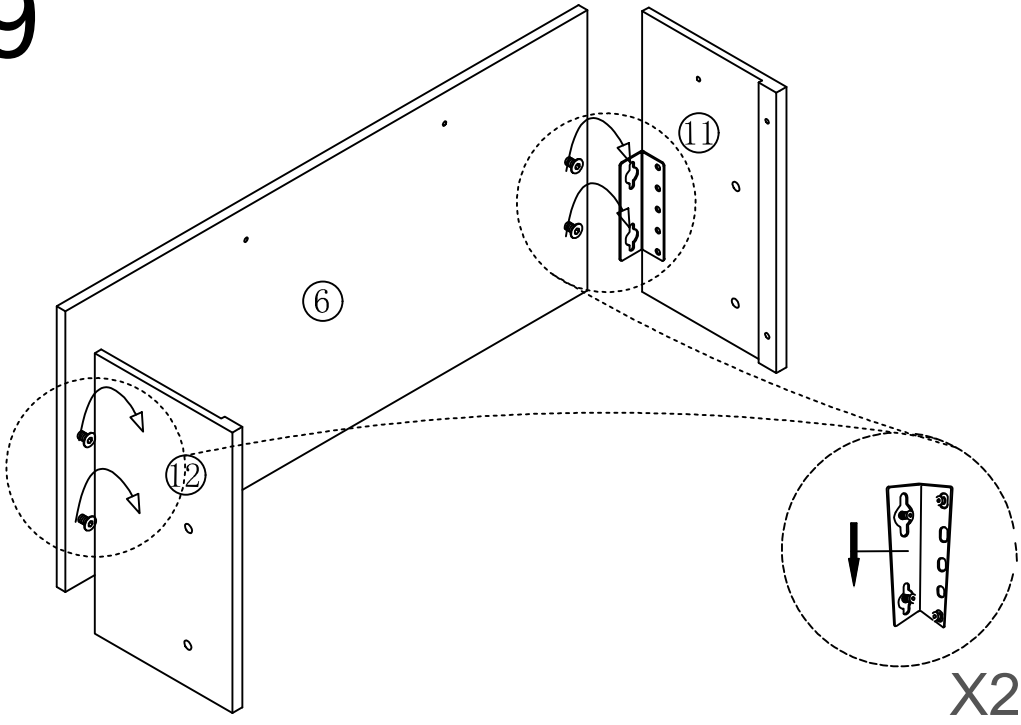

10

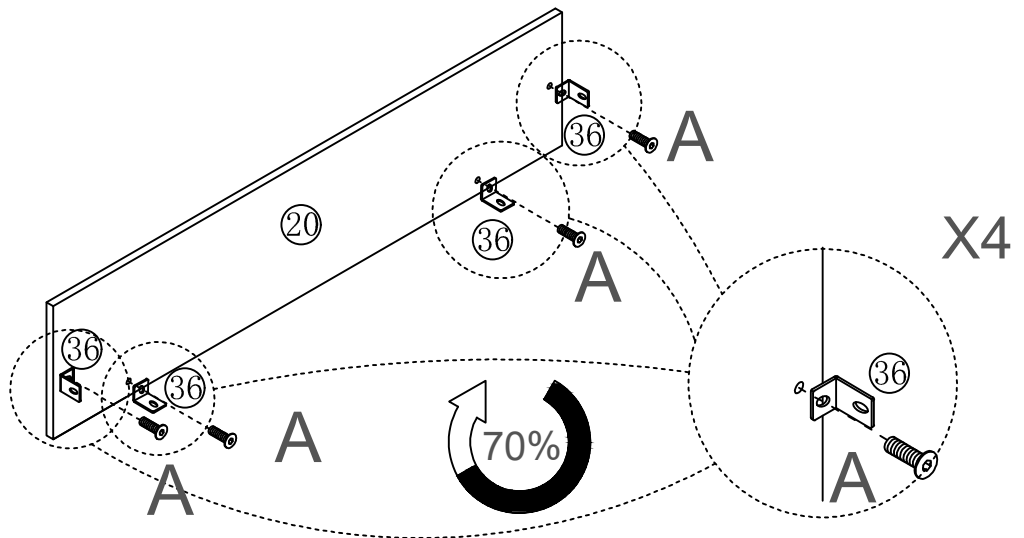

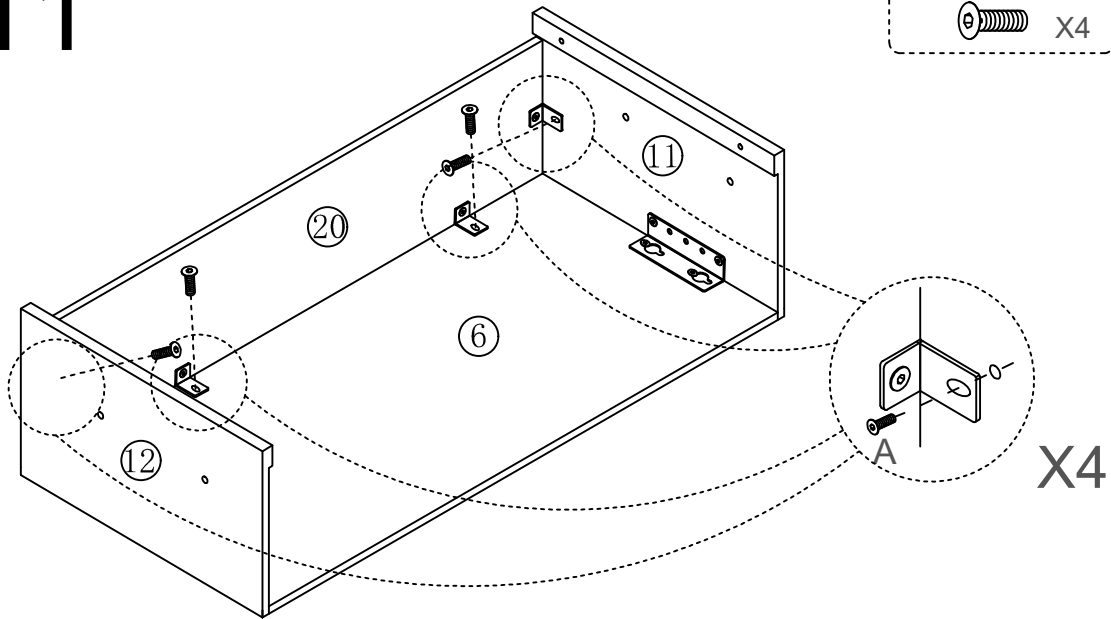

# 11

A M8\*16  
 X4



DE: Bitte alle Schrauben festziehen.  
EN: Please tighten all the screws.  
FR: Veuillez serrer tous les vis.  
IT: Per favore, stringete tutti i viti.  
ES: Por favor, apriete todos los tornillos.

# 12

G  X4  
C M8\*45  
 X4

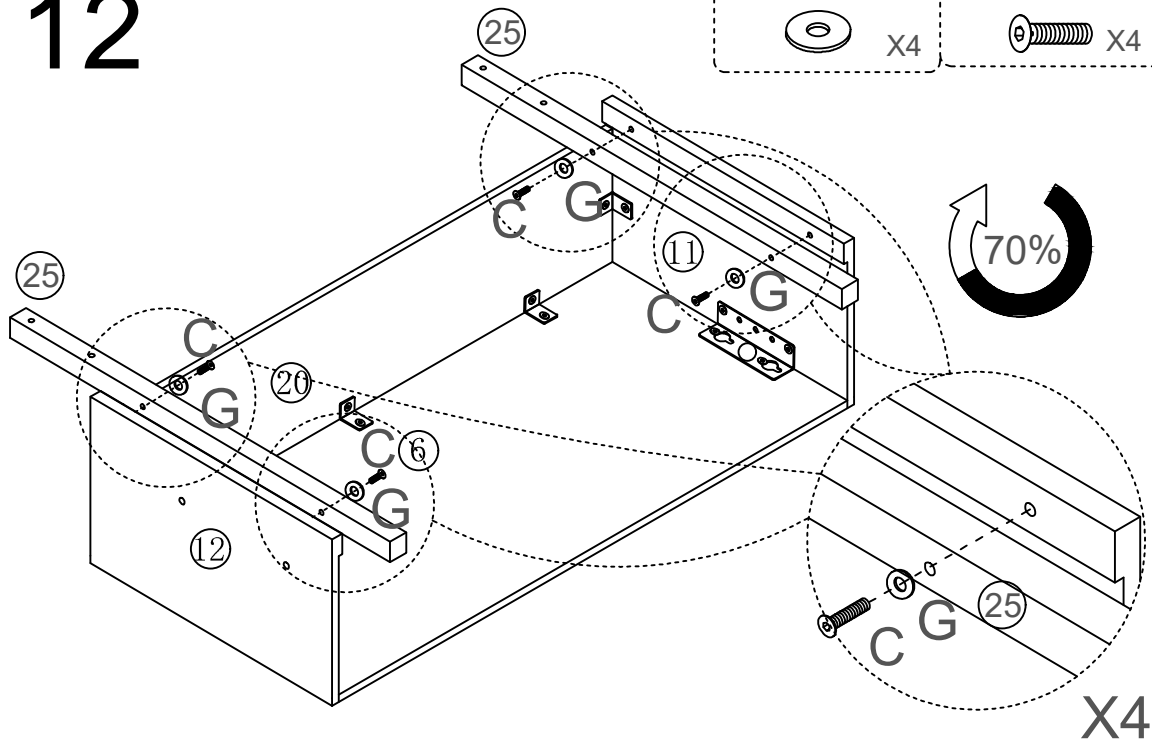

# 13

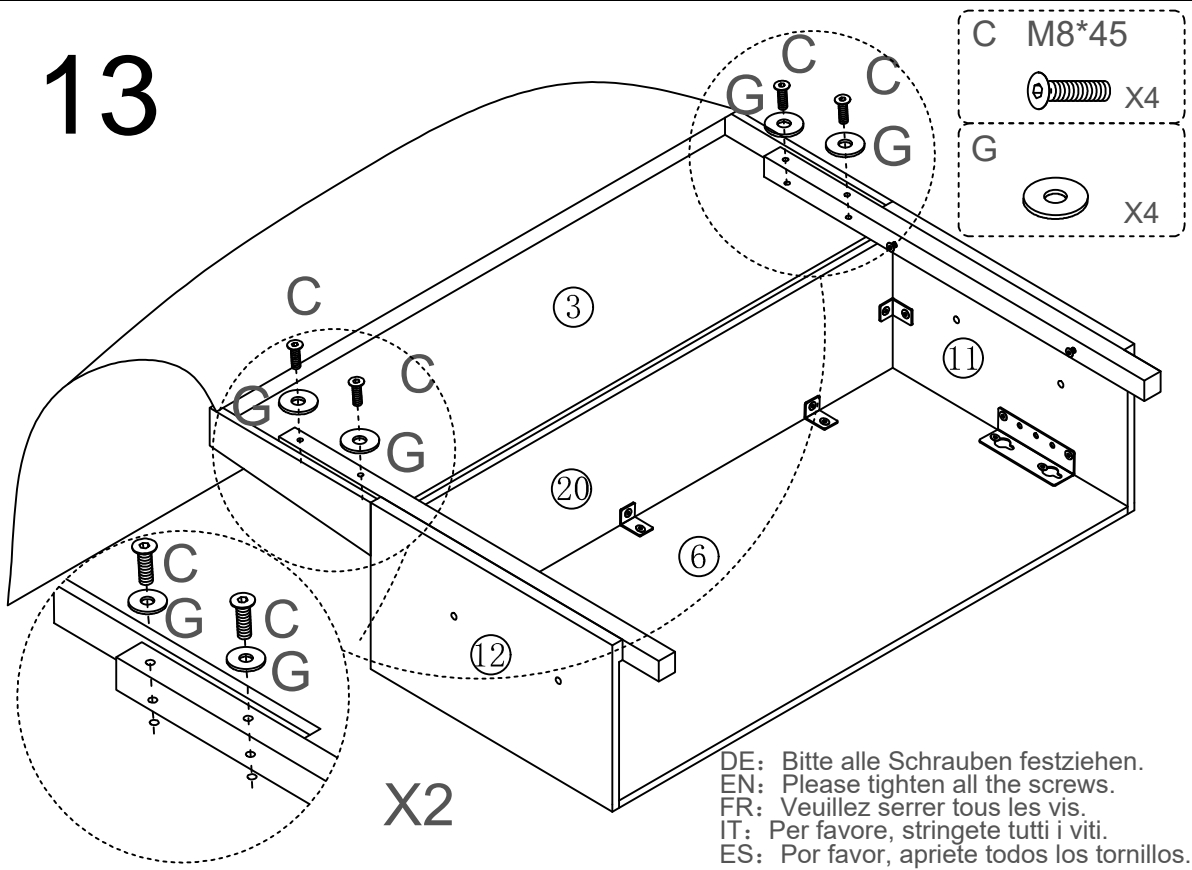

DE: Bitte alle Schrauben festziehen.  
 EN: Please tighten all the screws.  
 FR: Veuillez serrer tous les vis.  
 IT: Per favore, stringete tutti i viti.  
 ES: Por favor, apriete todos los tornillos.

# 14

DE: Bitte montieren Sie die Seite mit dem Aufkleber oben.  
 EN: Please assemble the side with the sticker on top.  
 FR: Veuillez assembler le côté avec l'autocollant sur le dessus.  
 IT: Si prega di assemblare il lato con la colla sopra.  
 ES: Por favor, ensamble el lado con la etiqueta en la parte superior.



(DE): Stille Aufkleber  
 (EN): Silent sticker  
 (FR): Stickers silencieux  
 (IT): Etichetta silenziosa  
 (ES): Estuche silencioso

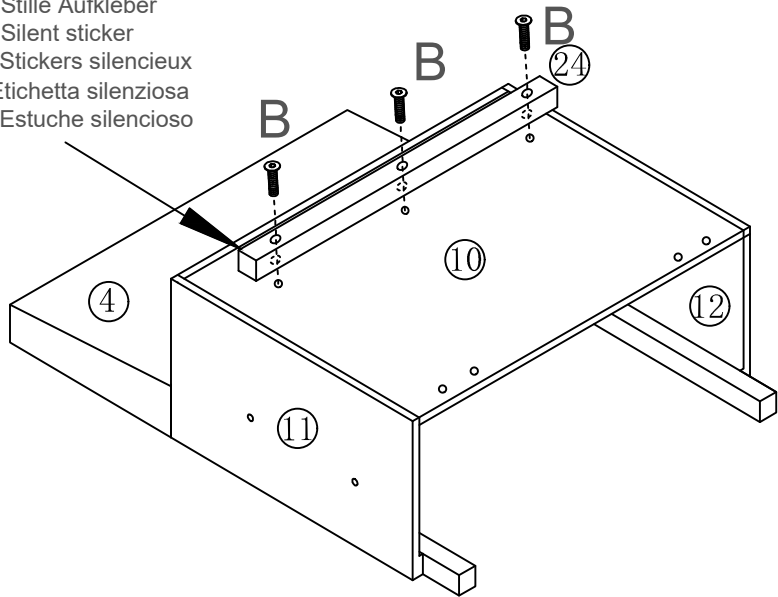

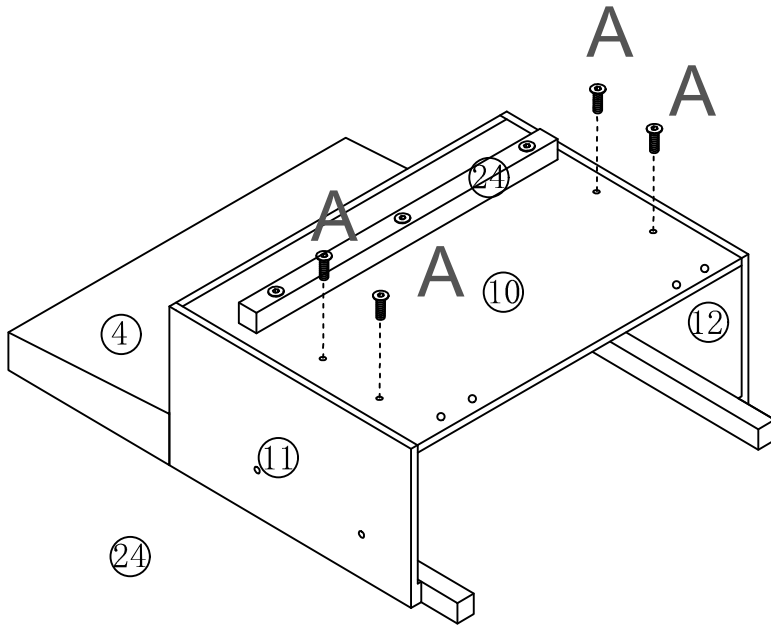

# 15

A M8\*16  
 X4



# 16

35  
 X4

A M8\*16  
 X8

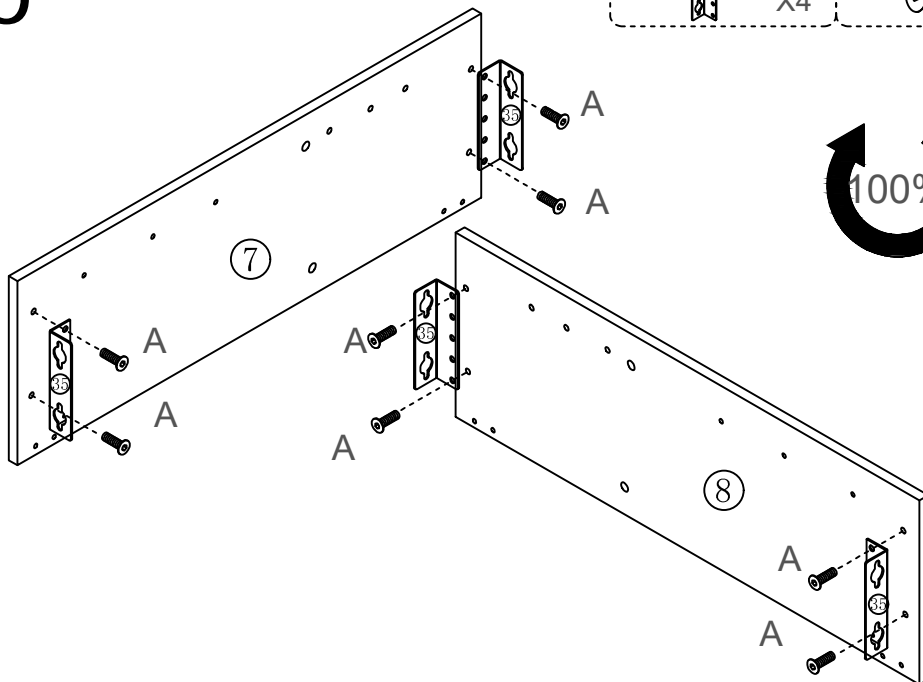

# 17

B M8\*37  
 X6

(DE):Stille Aufkleber  
(EN):Silent sticker  
(FR):Stickers silencieux  
(IT):Etichetta silenziosa  
(ES):Estuche silencioso

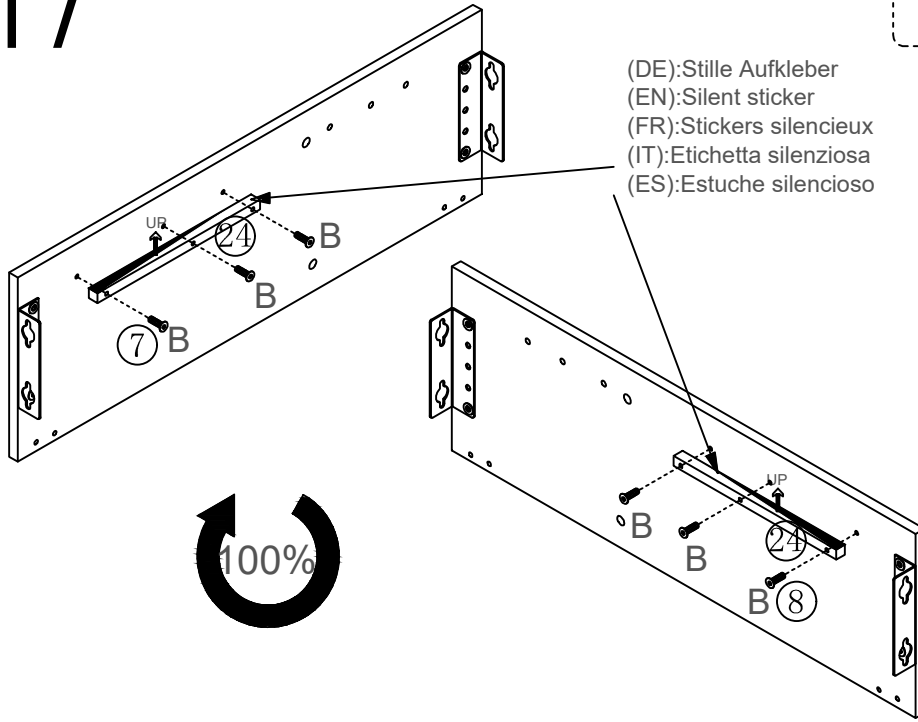

# 18

A M8\*16  
 X4

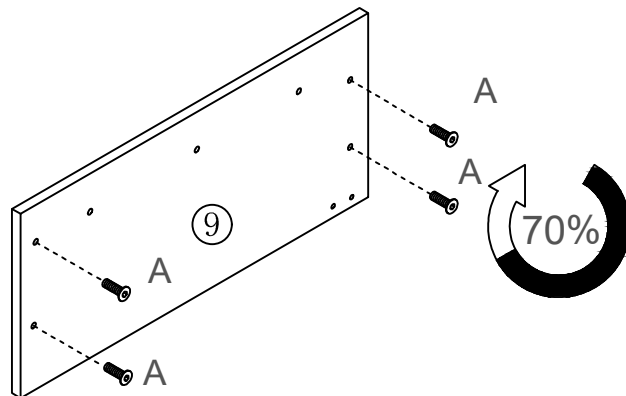

# 19

B M8\*37  
 X3

(DE):Stille Aufkleber  
(EN):Silent sticker  
(FR):Stickers silencieux  
(IT):Etichetta silenziosa  
(ES):Estuche silencioso

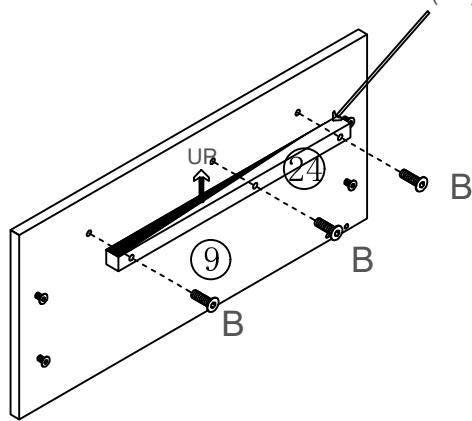

# 20

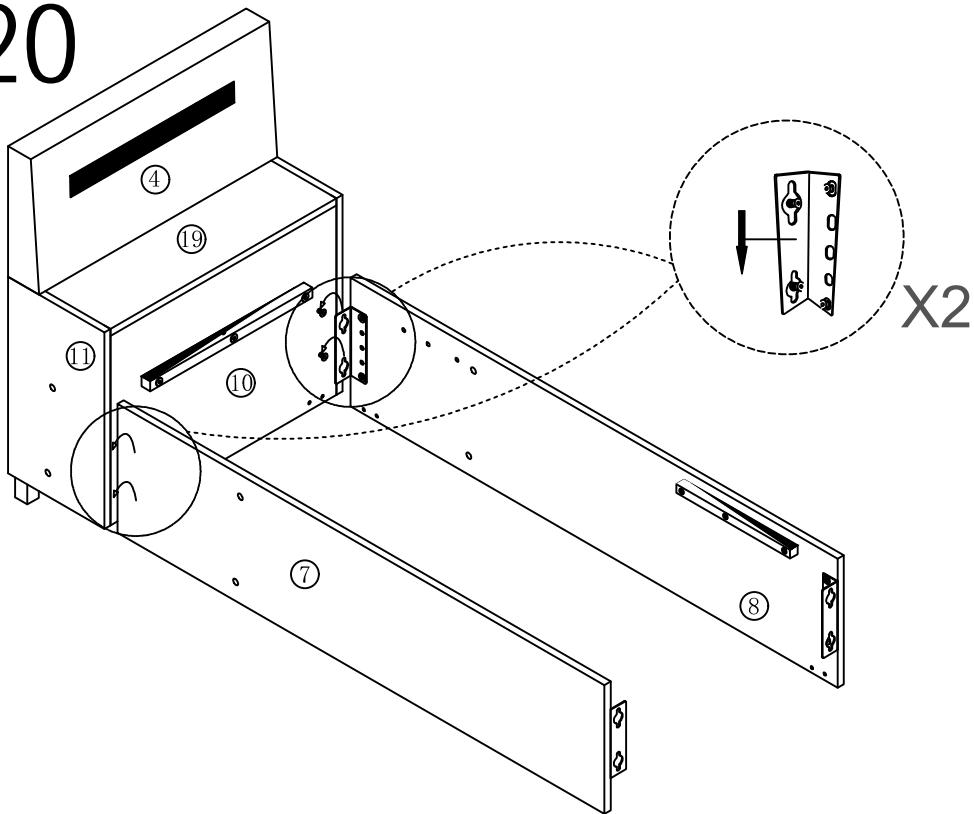

# 21

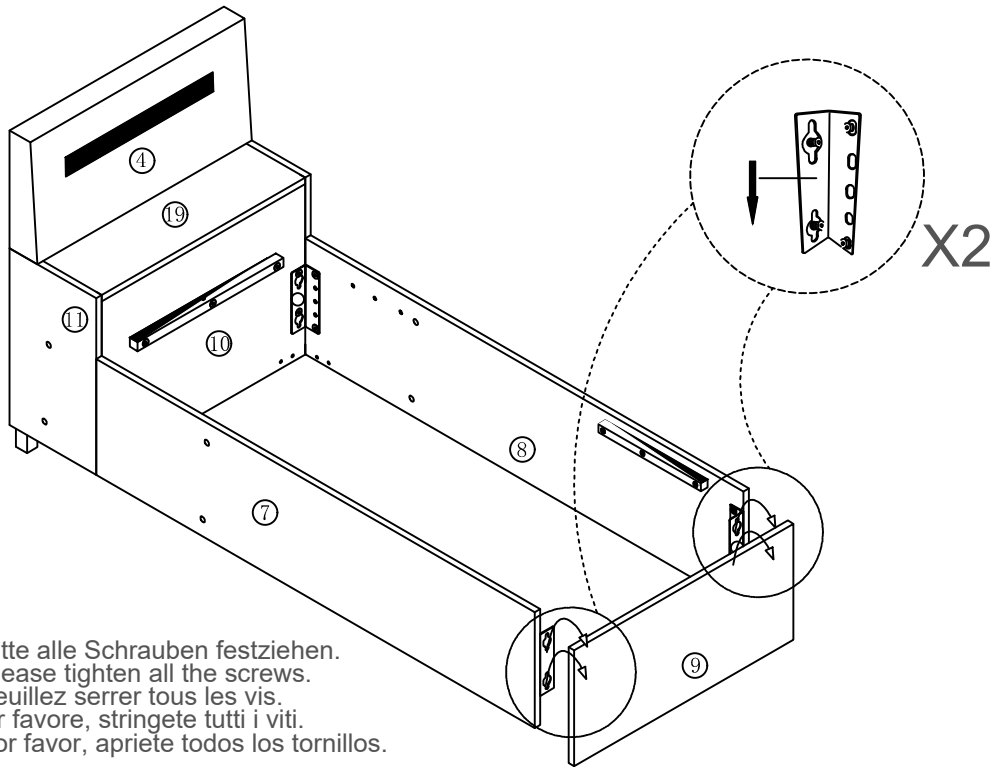

DE: Bitte alle Schrauben festziehen.  
EN: Please tighten all the screws.  
FR: Veuillez serrer tous les vis.  
IT: Per favore, stringete tutti i viti.  
ES: Por favor, apriete todos los tornillos.

# 22

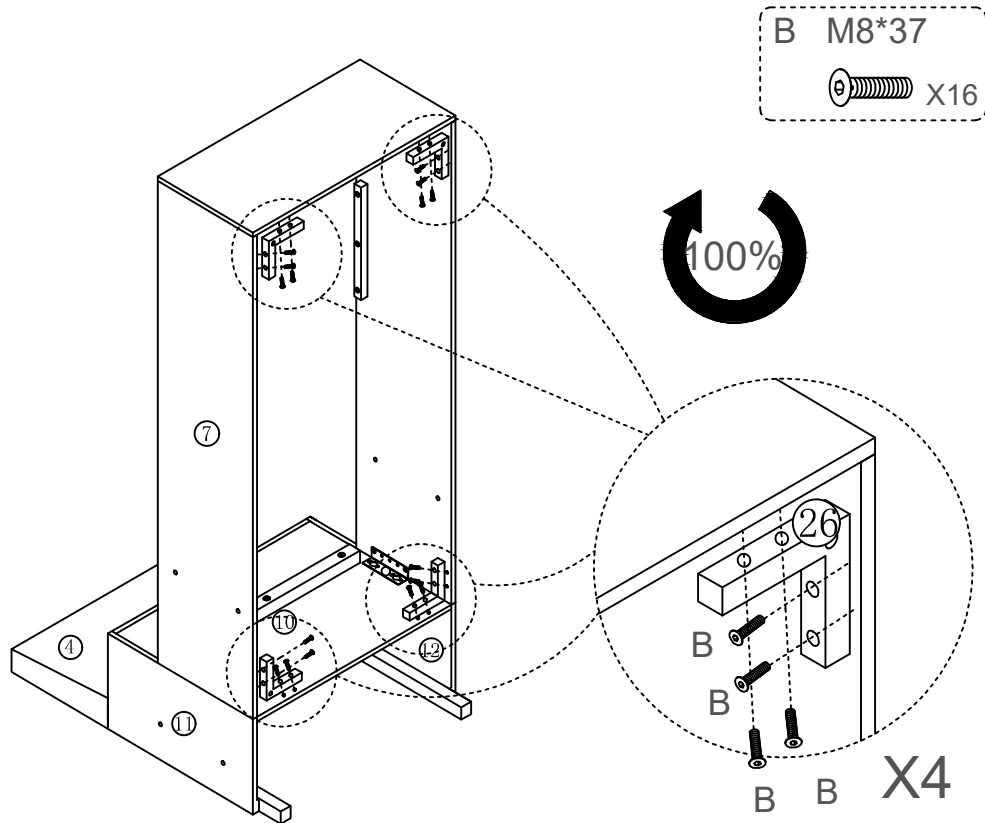

# 23

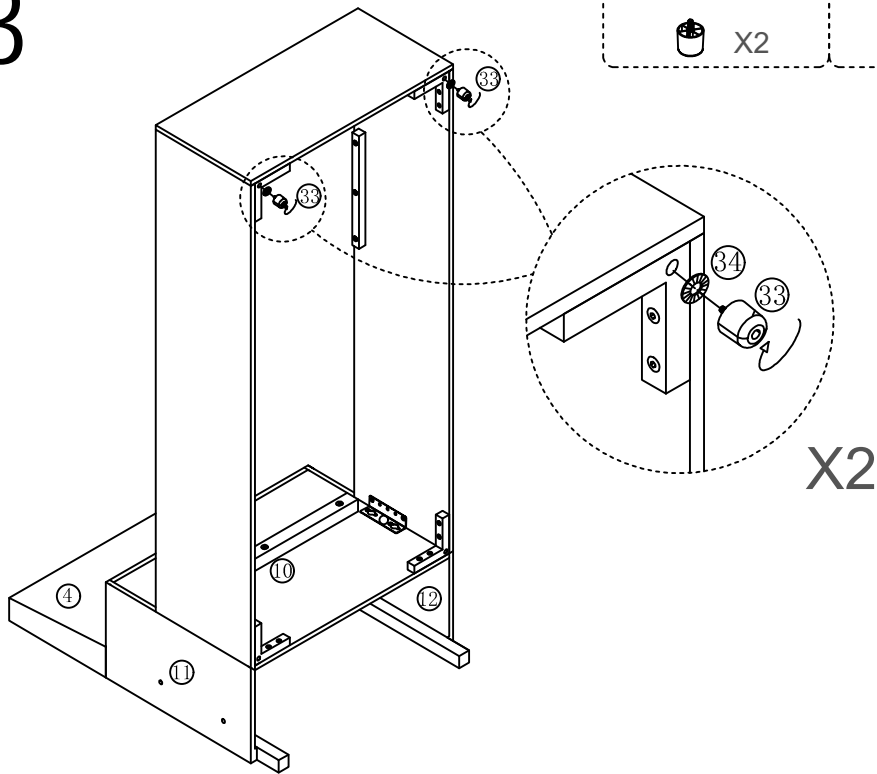

# 24

DE: Bitte montieren Sie die Seite mit dem Aufkleber oben.  
 EN: Please assemble the side with the sticker on top  
 FR: Veuillez assembler le côté avec l'autocollant sur le dessus.  
 IT: Si prega di assemblare il lato con la colla sopra.  
 ES: Por favor, ensamble el lado con la etiqueta en la parte superior.

**B M8\*37**  
 X4

(DE): Stille Aufkleber  
 (EN): Silent sticker  
 (FR): Stickers silencieux  
 (IT): Etichetta silenziosa  
 (ES): Estuche silencioso

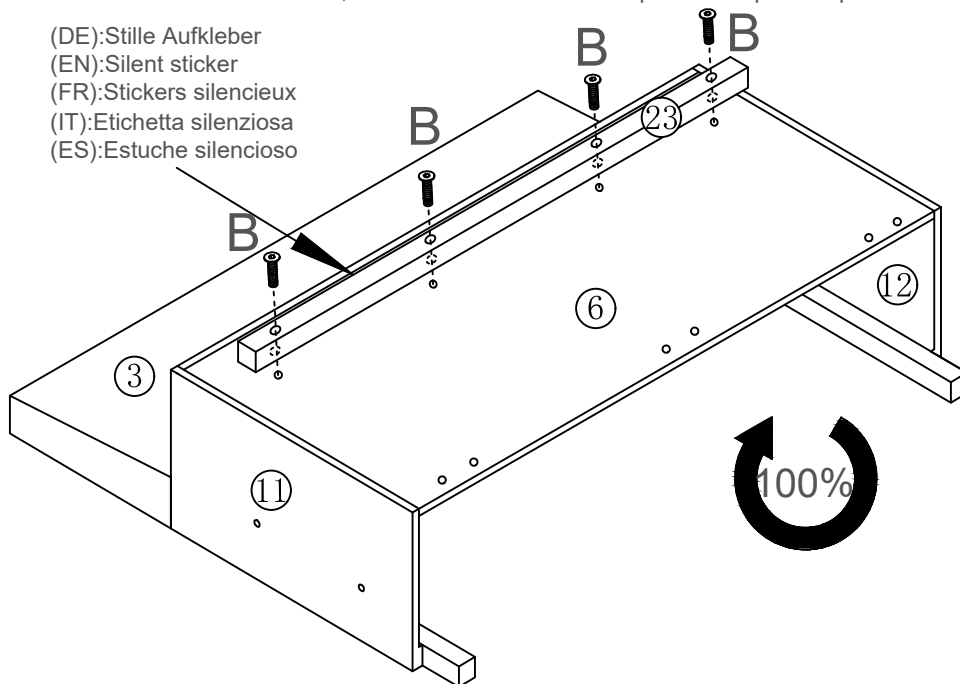

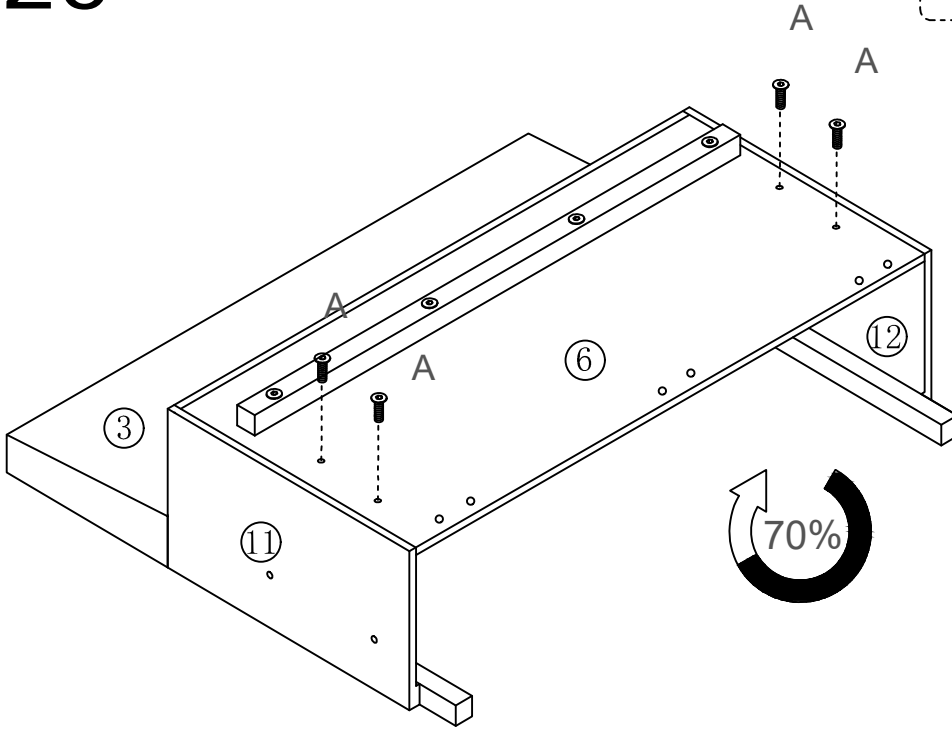

# 25

A M8\*16  
 X4



# 26

35  
 X4

A M8\*16  
 X8

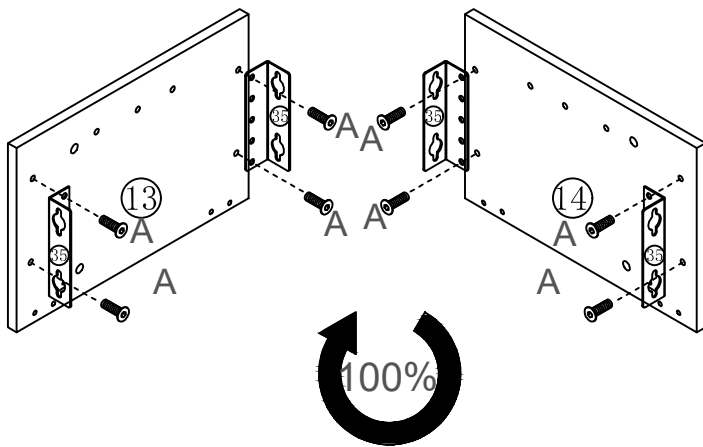

# 27

A M8\*16  
 X4

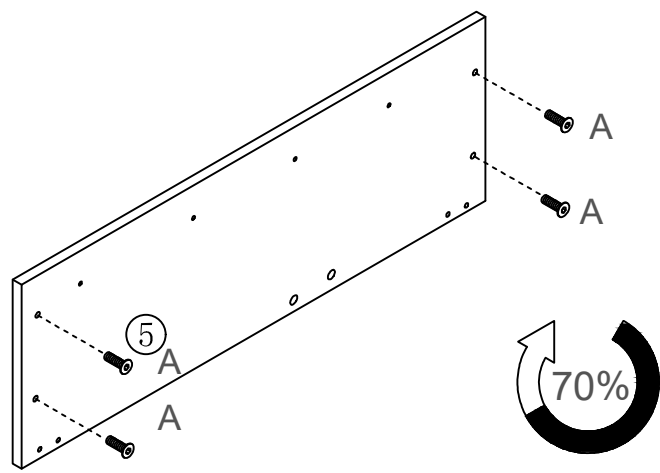

# 28

DE: Bitte montieren Sie die Seite mit dem Aufkleber oben.  
EN: Please assemble the side with the sticker on top.  
FR: Veuillez assembler le côté avec l'autocollant sur le dessus.  
IT: Si prega di assemblare il lato con la colla sopra.  
ES: Por favor, ensamble el lado con la etiqueta en la parte superior.

B M8\*37  
 X4

(DE):Stille Aufkleber  
(EN):Silent sticker  
(FR):Stickers silencieux  
(IT):Etichetta silenziosa  
(ES):Estuche silencioso

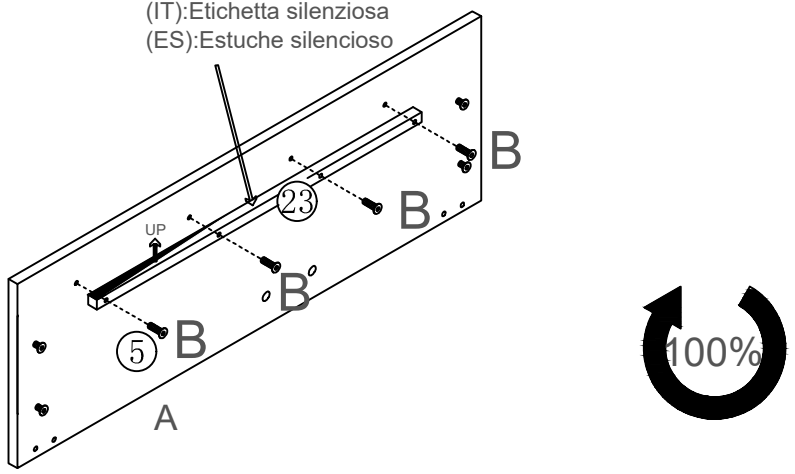

# 29

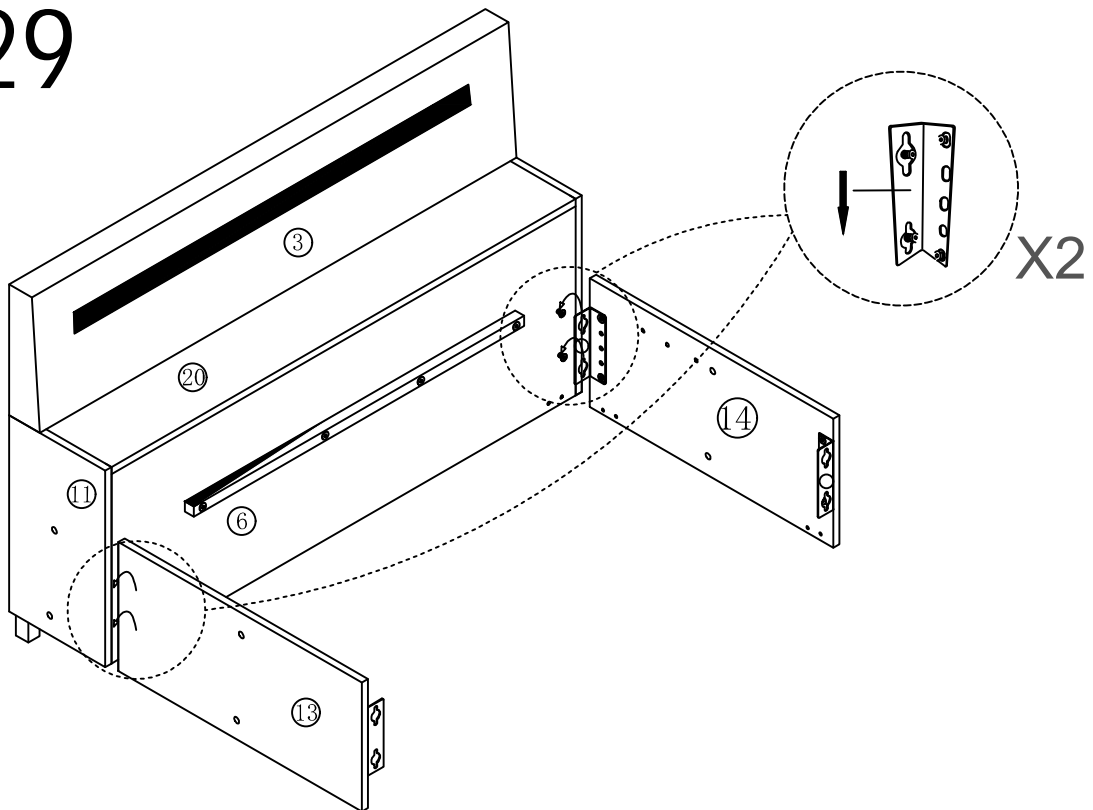

# 30

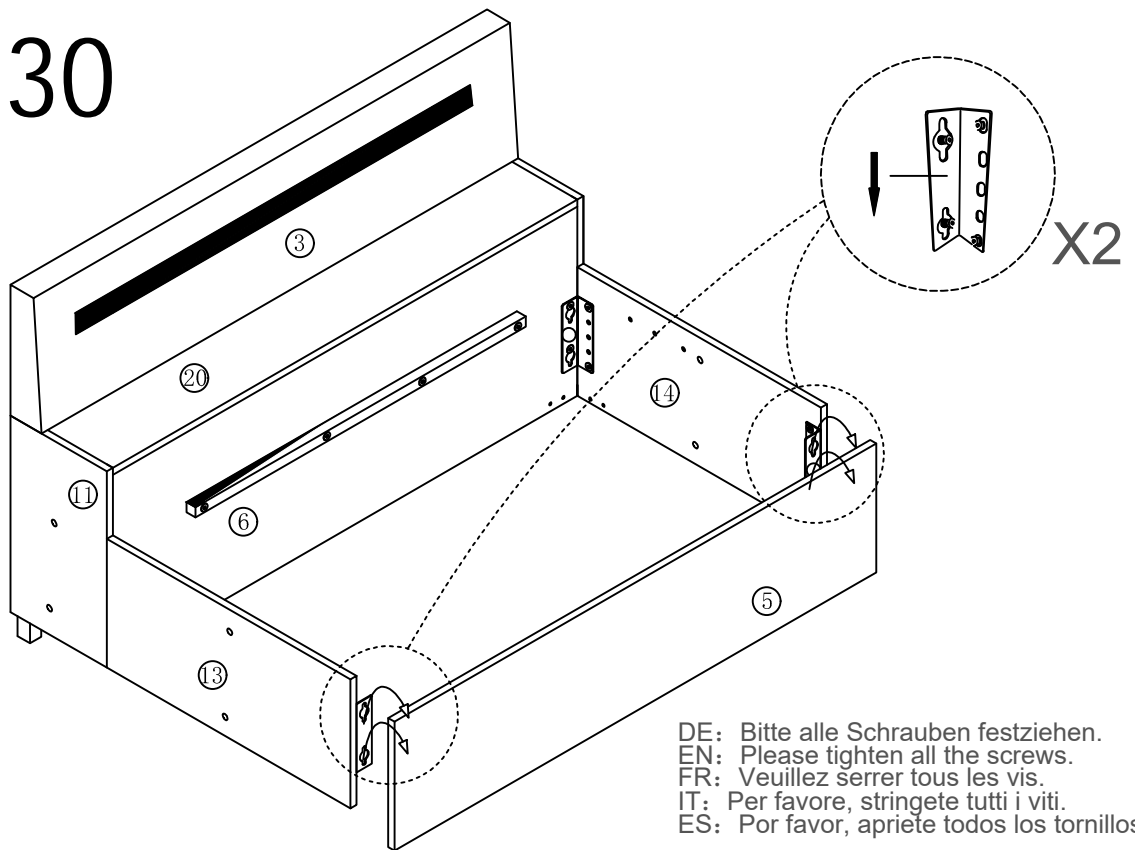

DE: Bitte alle Schrauben festziehen.  
EN: Please tighten all the screws.  
FR: Veuillez serrer tous les vis.  
IT: Per favore, stringete tutti i viti.  
ES: Por favor, apriete todos los tornillos.

# 31

B M8\*37  
 X16

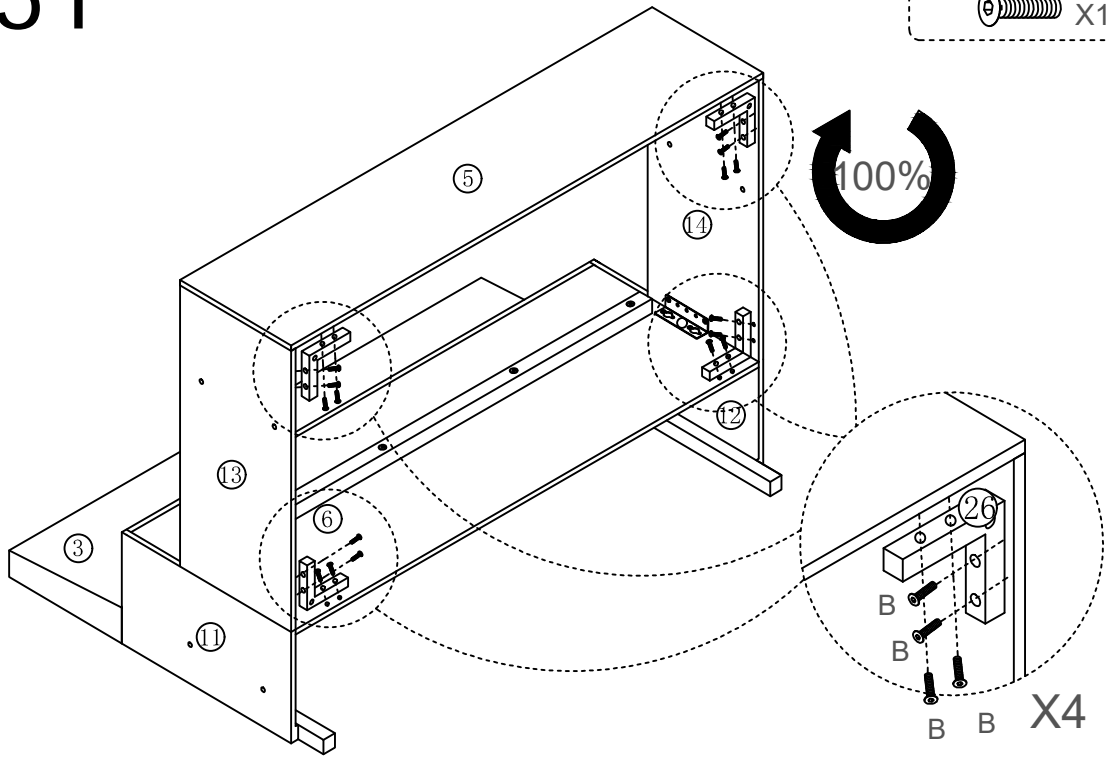

# 32

33 X2      34 X2

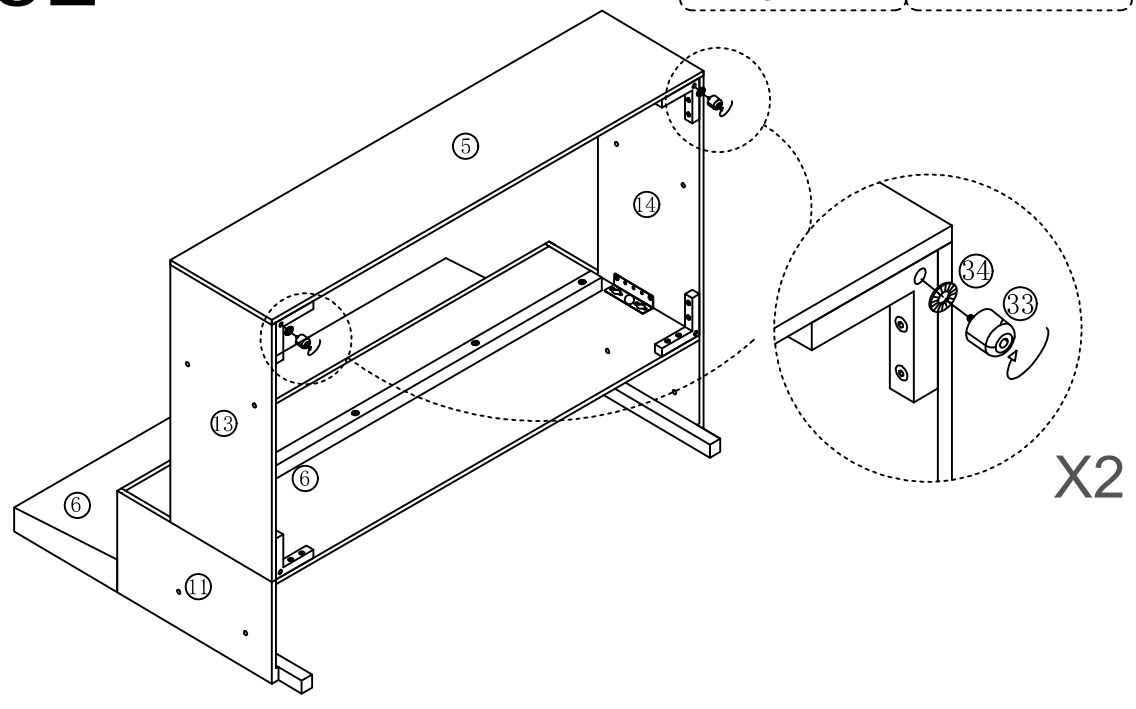

# 33-L

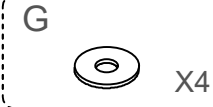
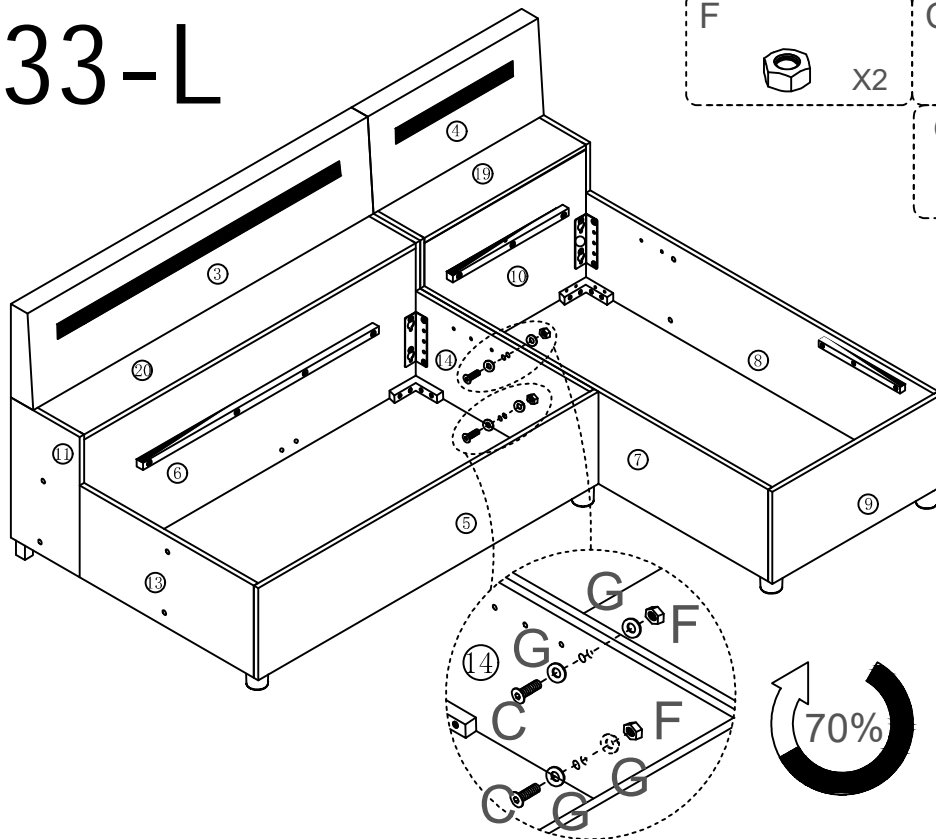

# 34-L

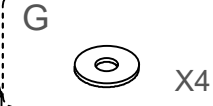
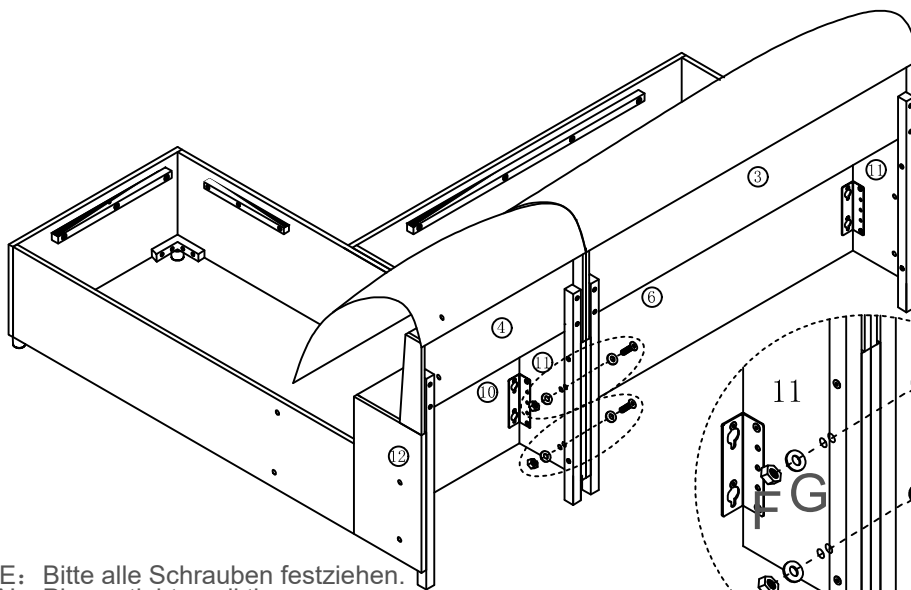

DE: Bitte alle Schrauben festziehen.  
EN: Please tighten all the screws.  
FR: Veuillez serrer tous les vis.  
IT: Per favore, stringete tutti i viti.  
ES: Por favor, apriete todos los tornillos.

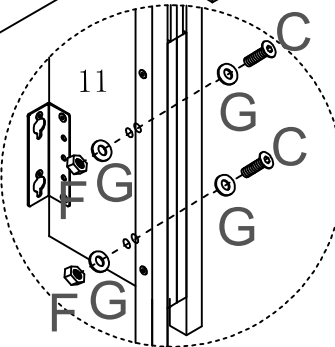

# 33-R

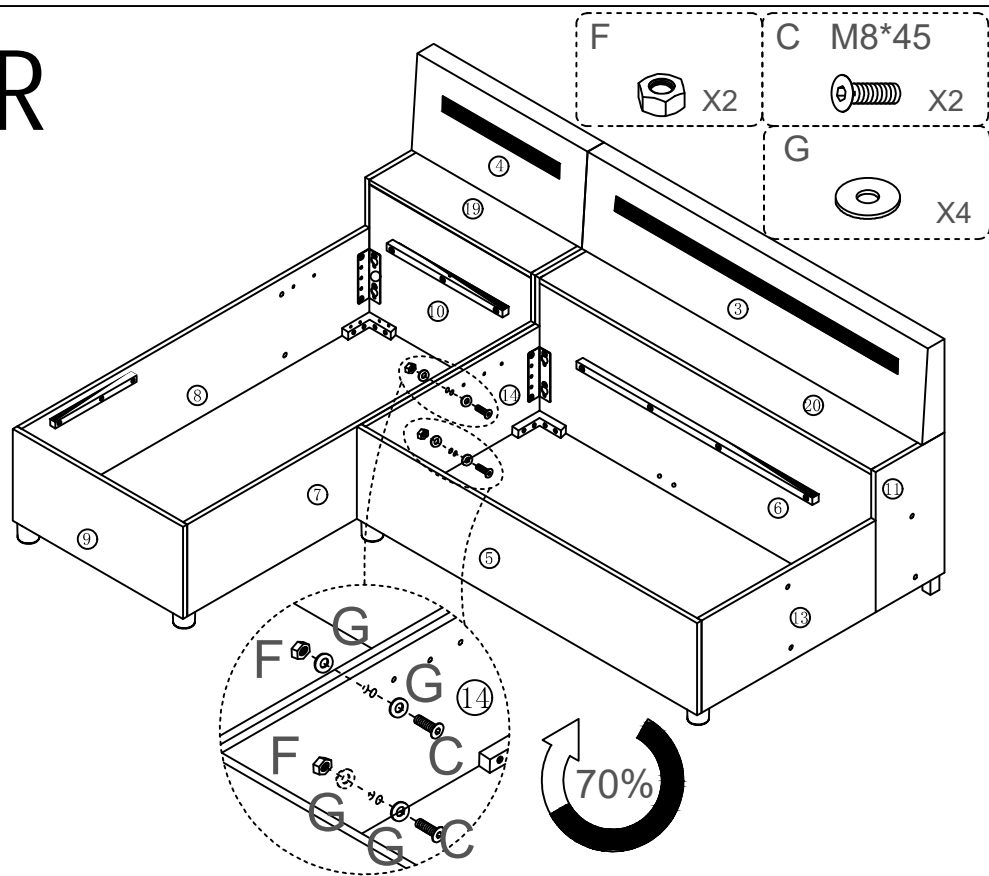

# 34-R

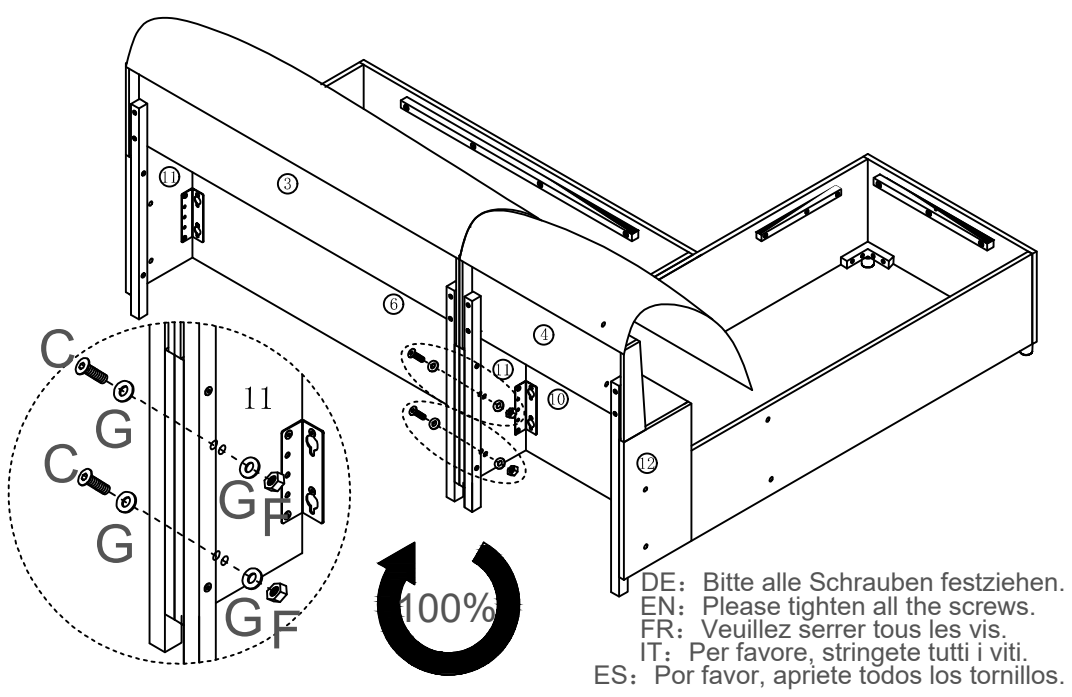

DE: Bitte alle Schrauben festziehen.  
 EN: Please tighten all the screws.  
 FR: Veuillez serrer tous les vis.  
 IT: Per favore, stringete tutti i viti.  
 ES: Por favor, apriete todos los tornillos.

# 35

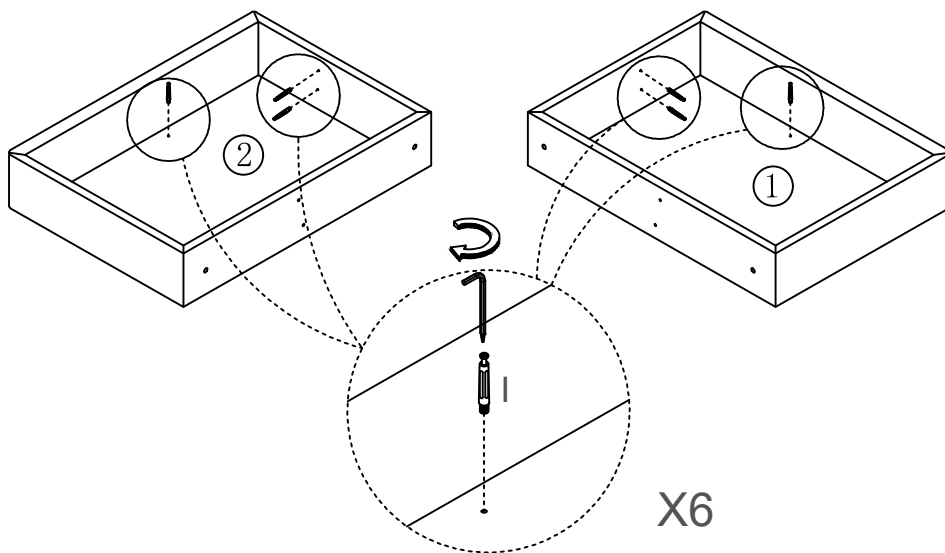
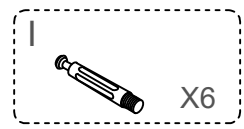

# 36

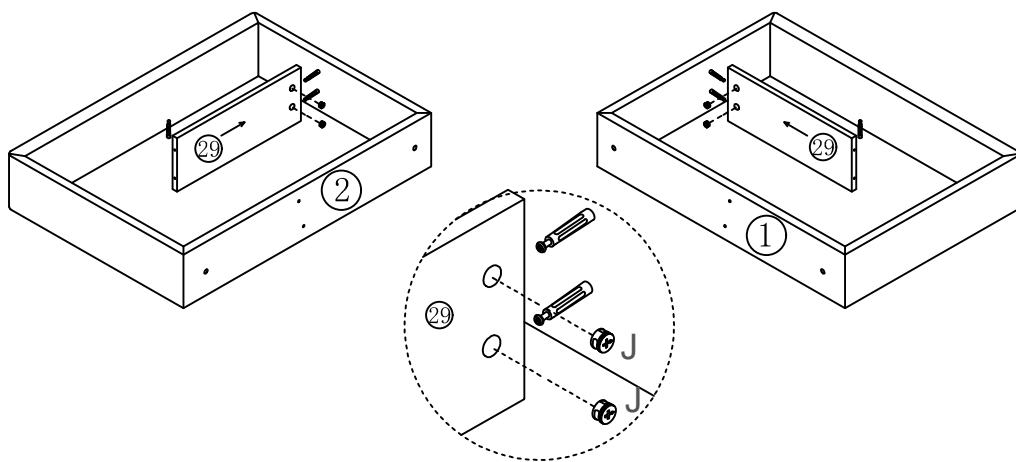
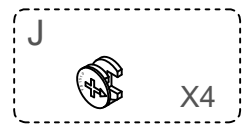

# 37

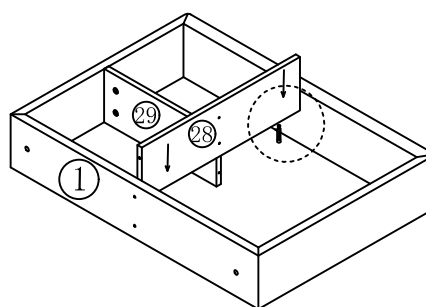
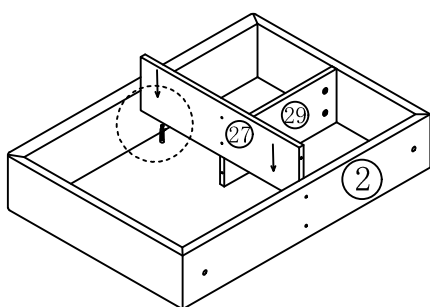
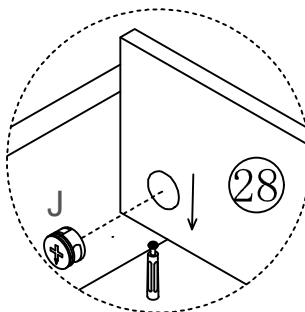
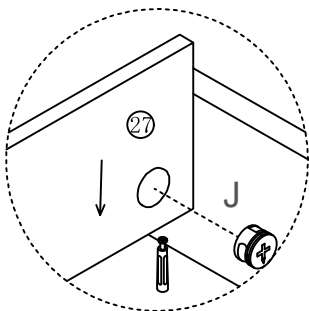
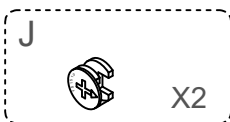

# 38

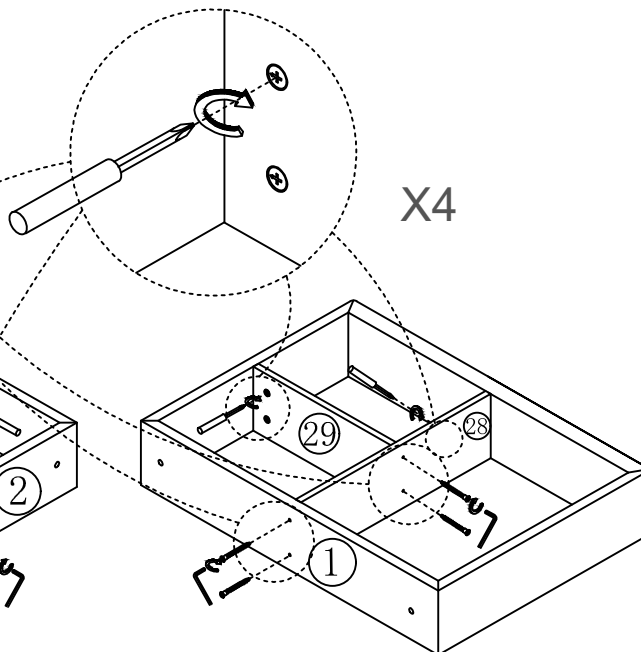
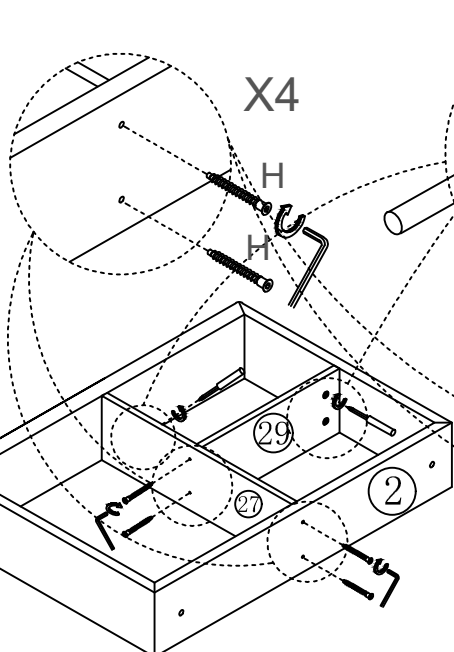

# 39

33



X4

34



X4

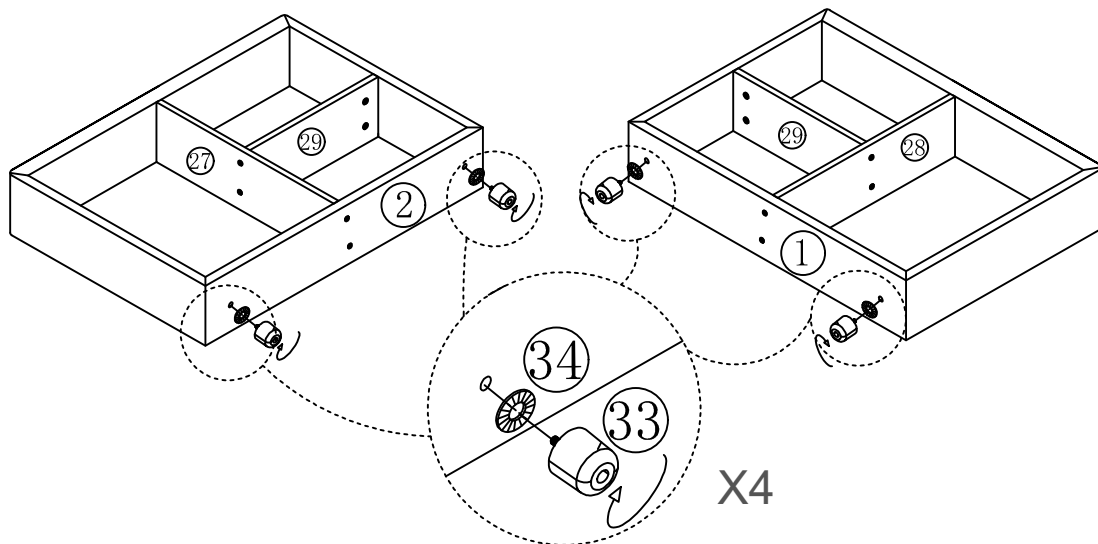

# 40

C M8\*45



X4

G



X4

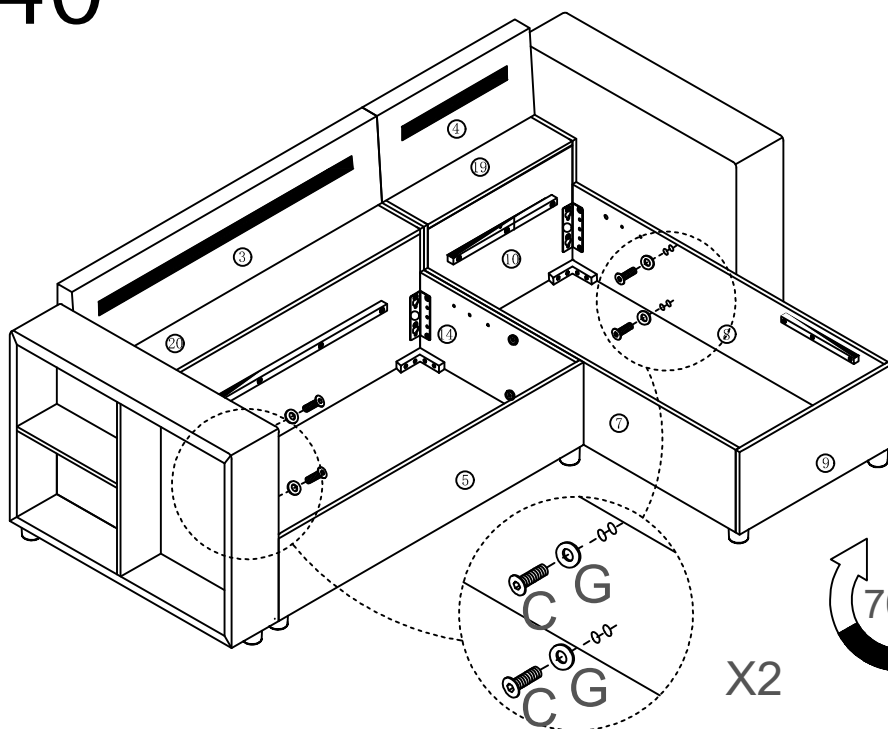

# 41

DE: Bitte alle Schrauben festziehen.  
EN: Please tighten all the screws.  
FR: Veuillez serrer tous les vis.  
IT: Per favore, stringete tutti i viti.  
ES: Por favor, apriete todos los tornillos.

C M8\*45



G

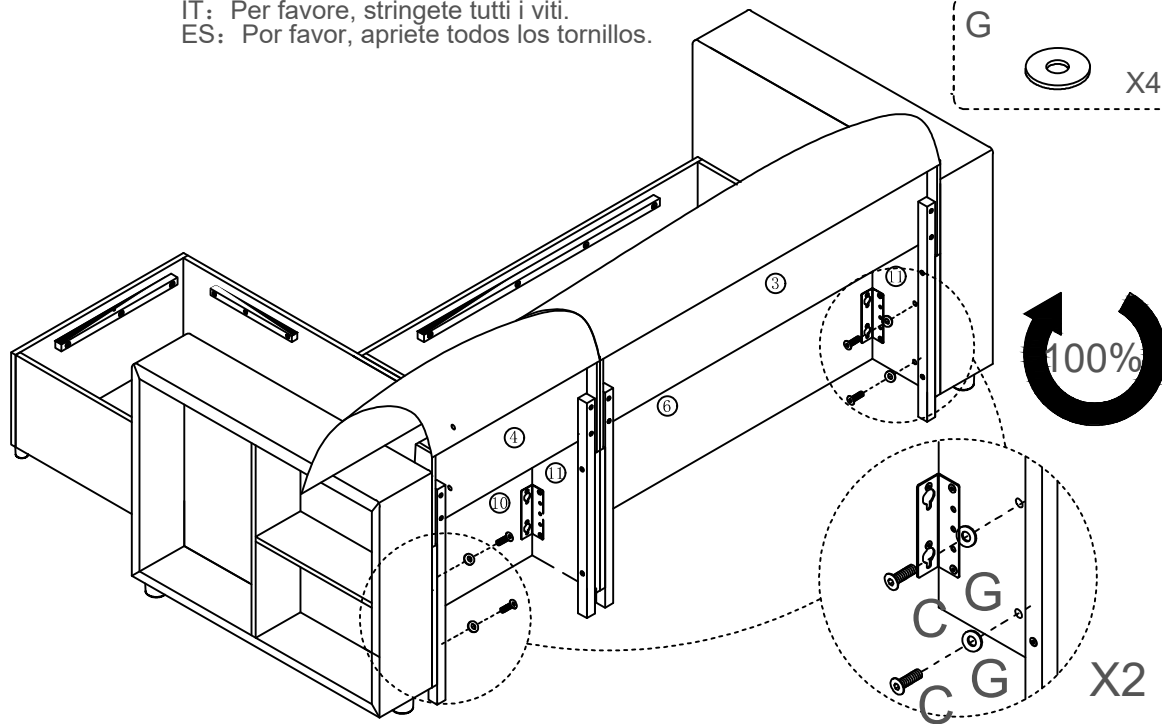

# 42

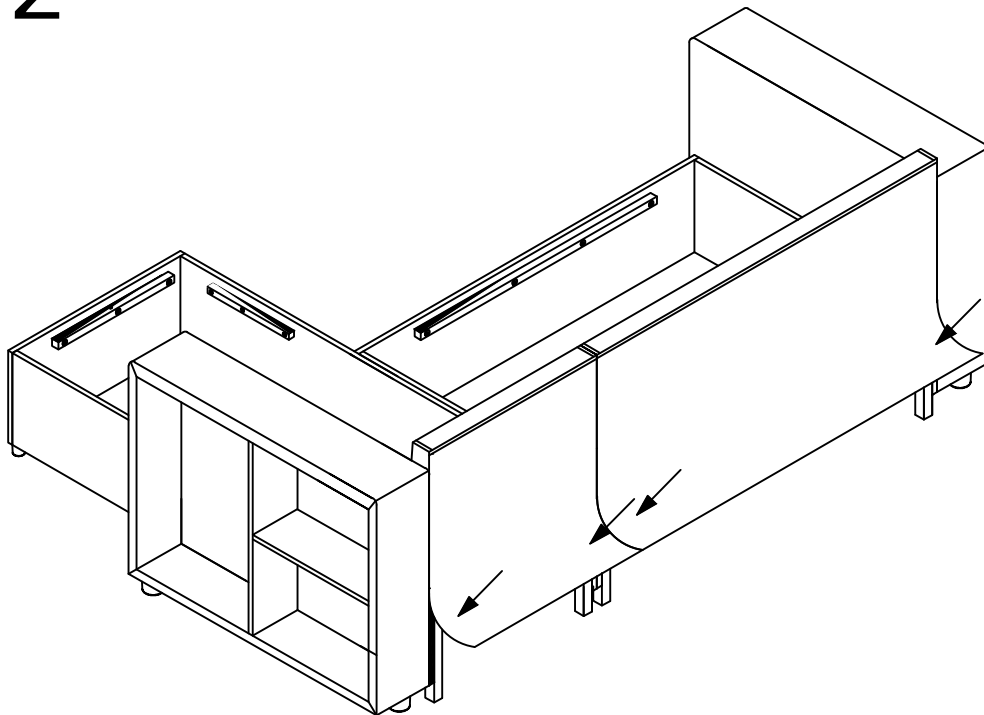

# 43-L

A M8\*16  
 X8

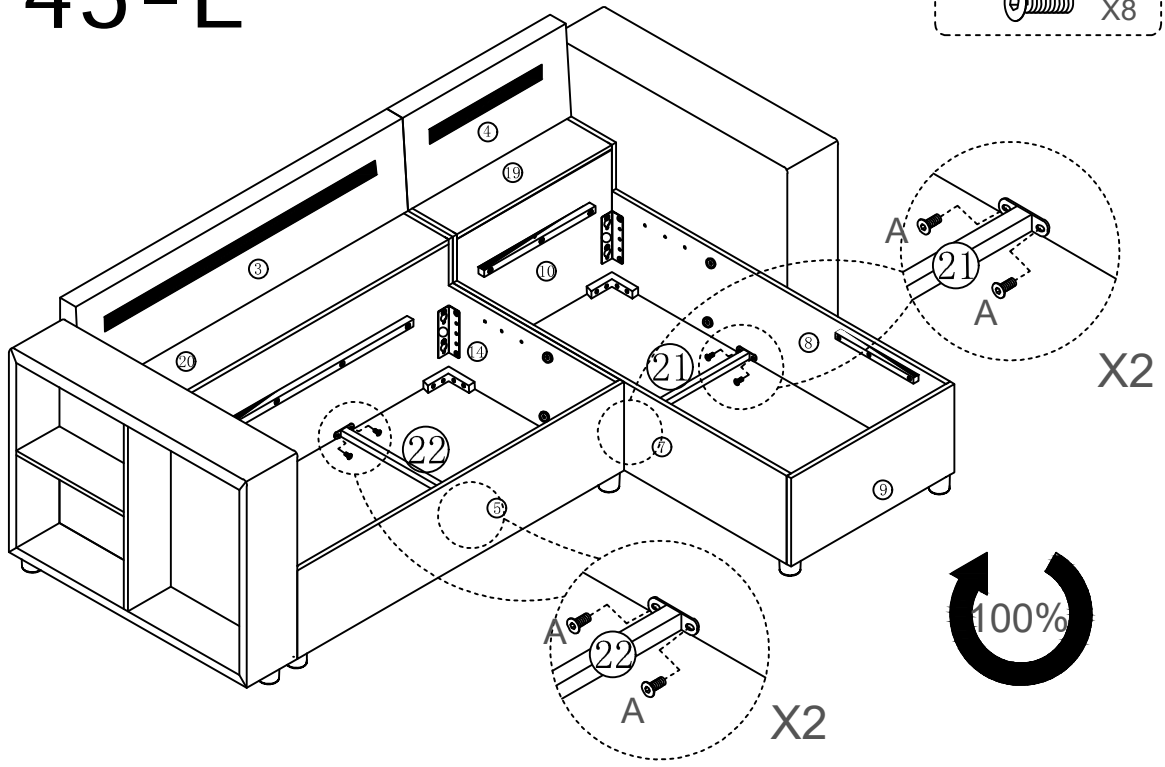

# 44-L

E M6\*20  
 X12

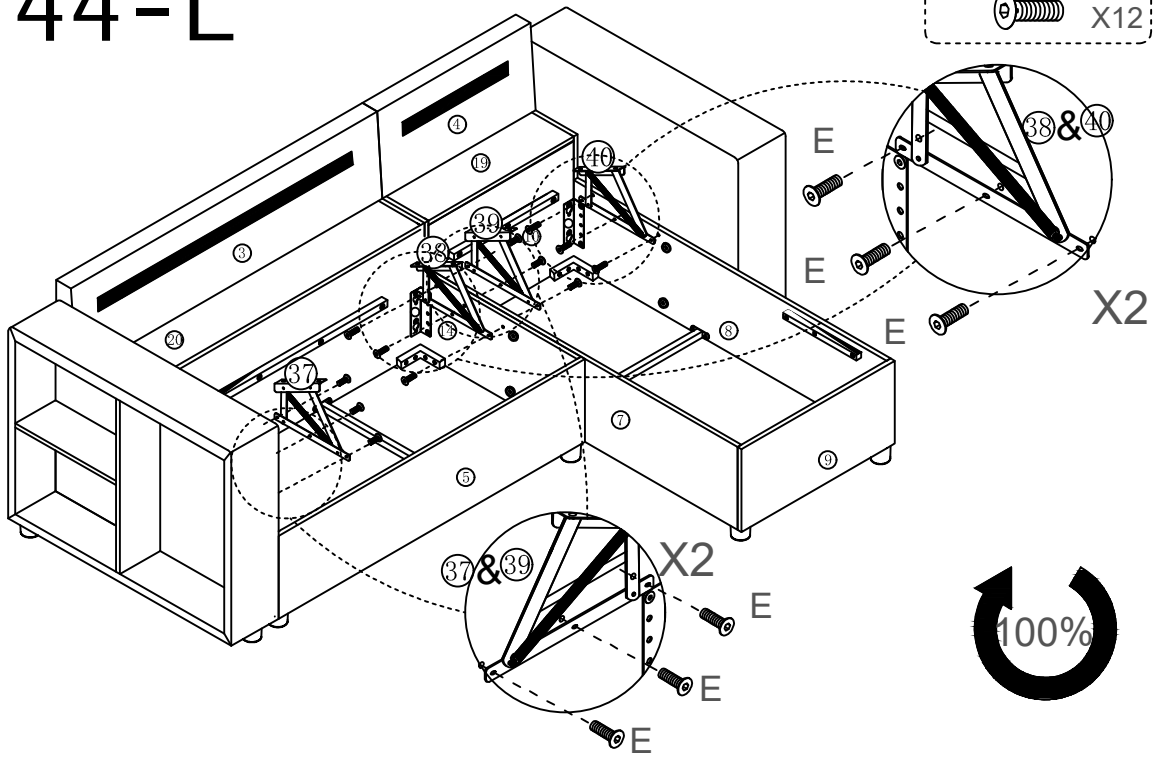

# 43-R

A M8\*16

X8 

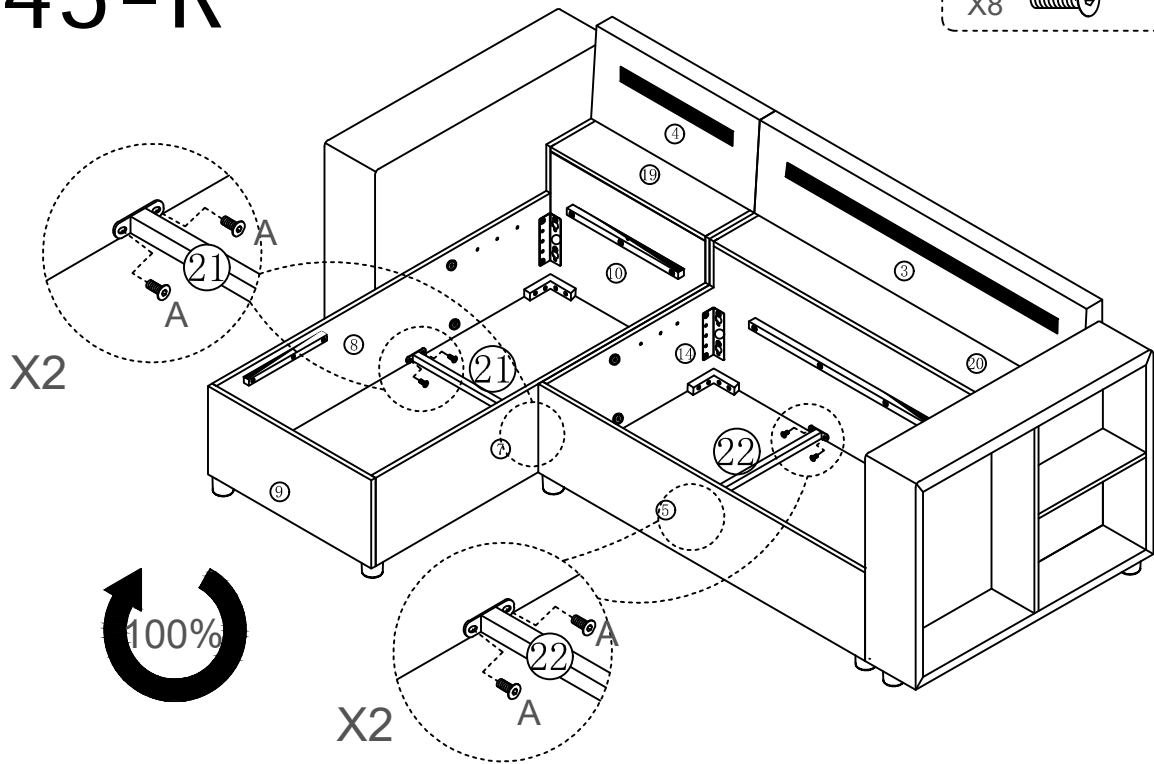

# 44-R

E M6\*20

X12 

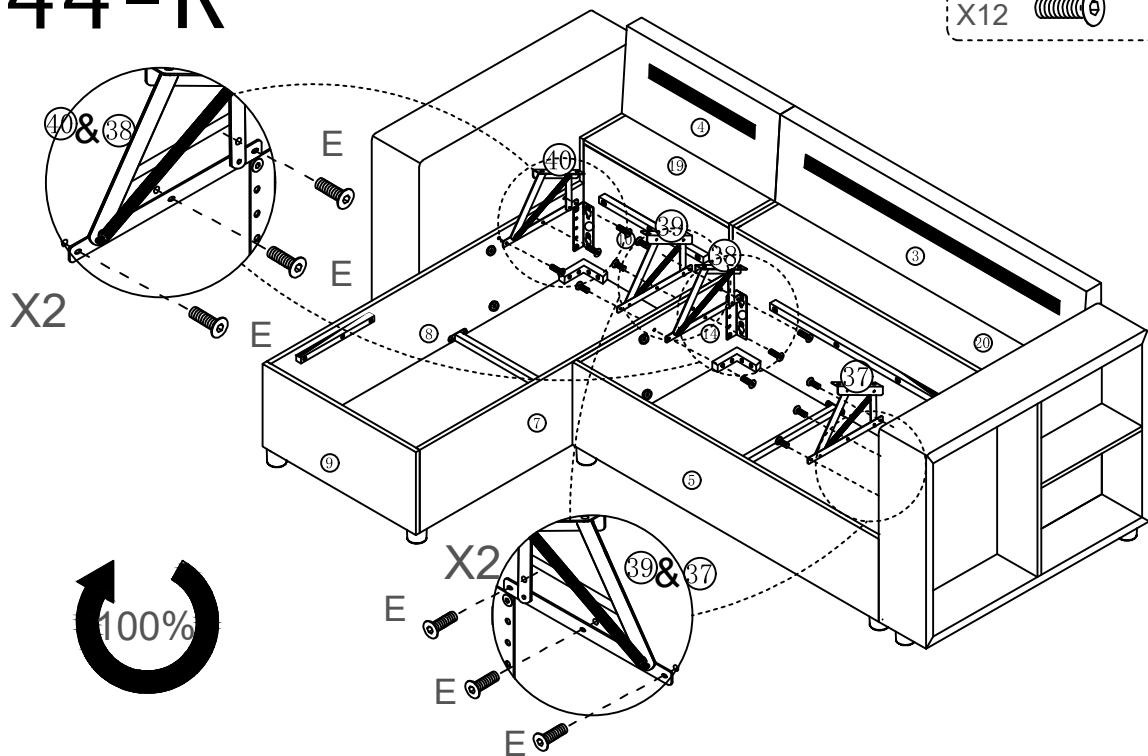

# 45-L

D M6\*12

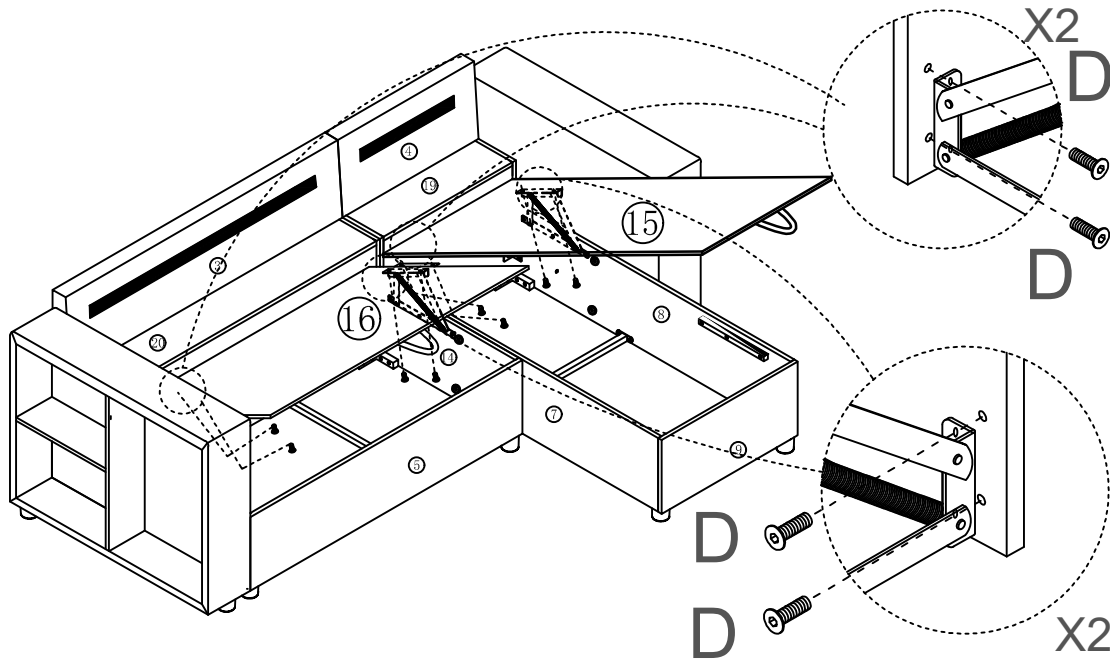

# 46-L

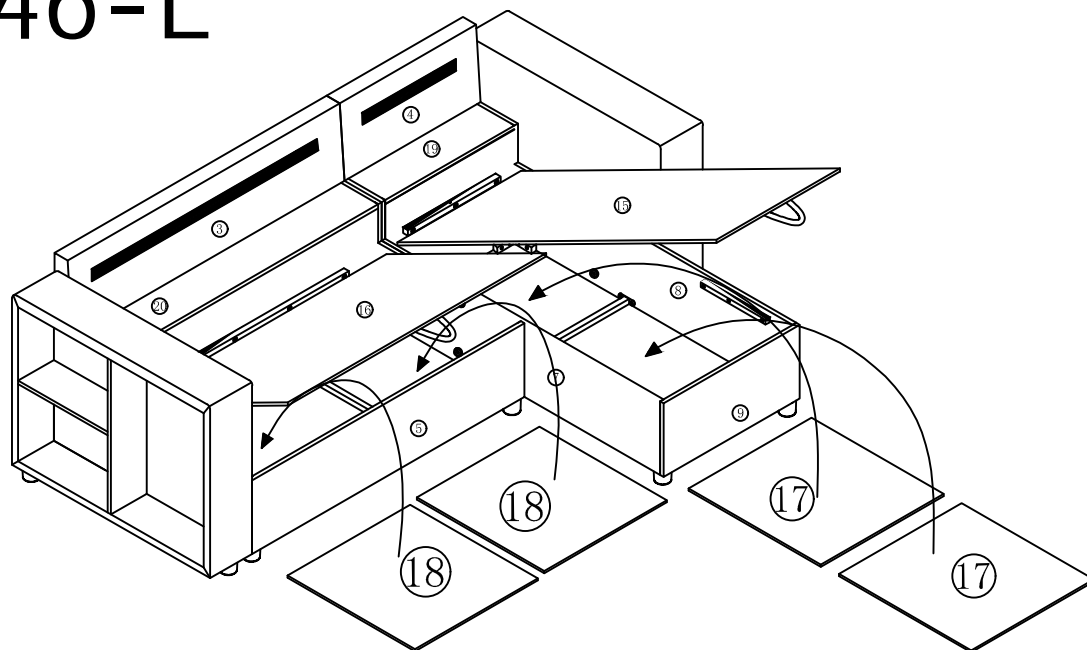

# 45-R

D M6\*12  
X12 

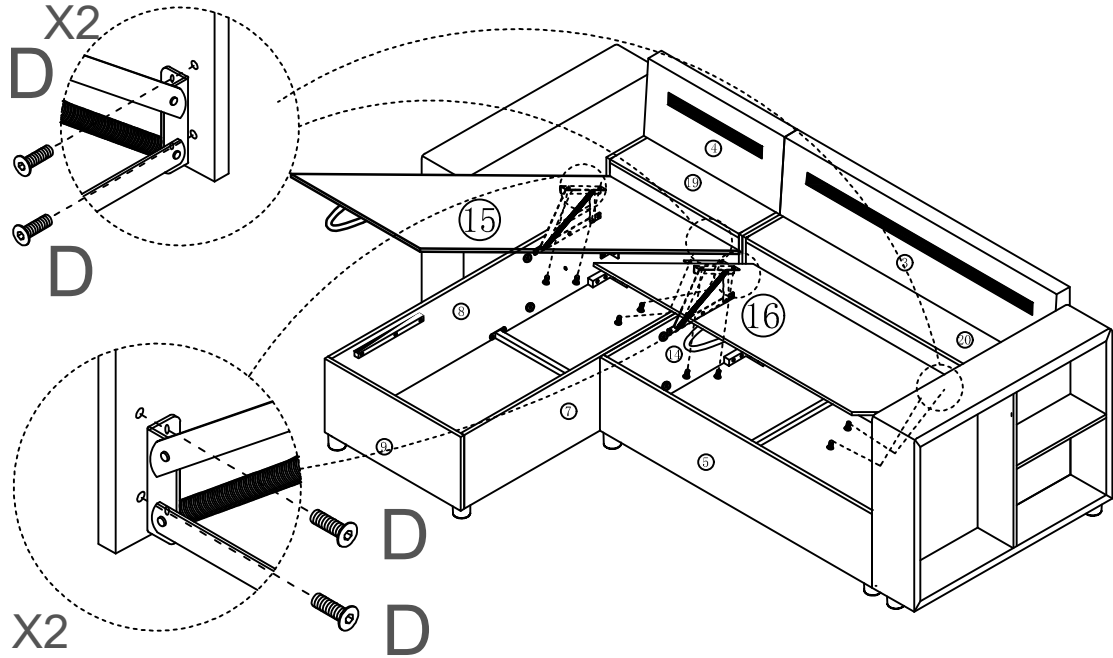

# 46-R

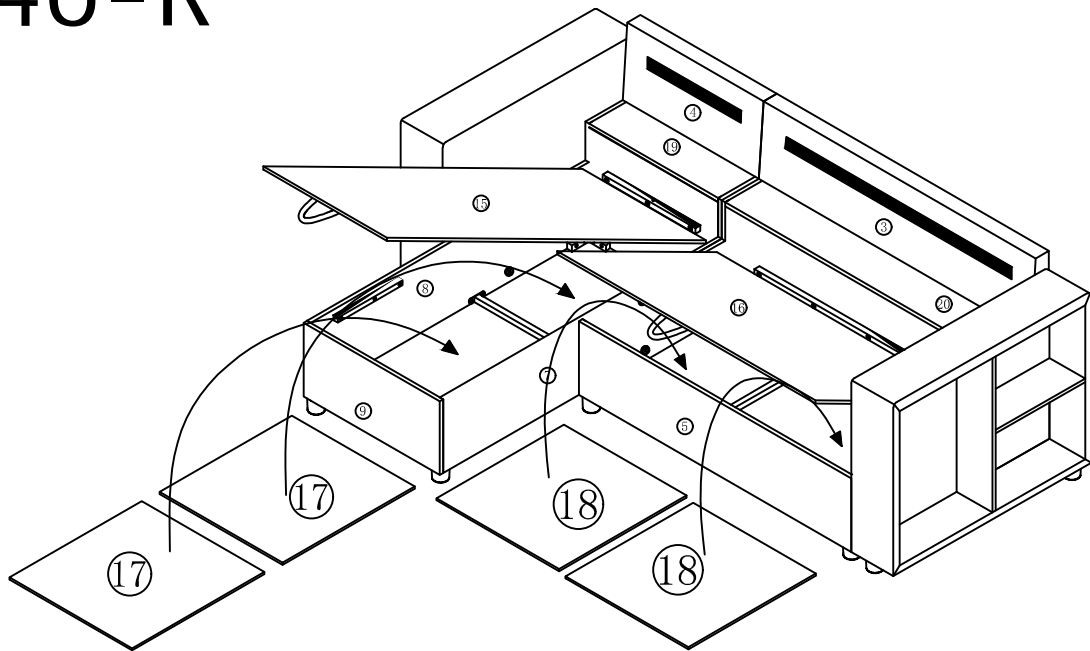

# 47

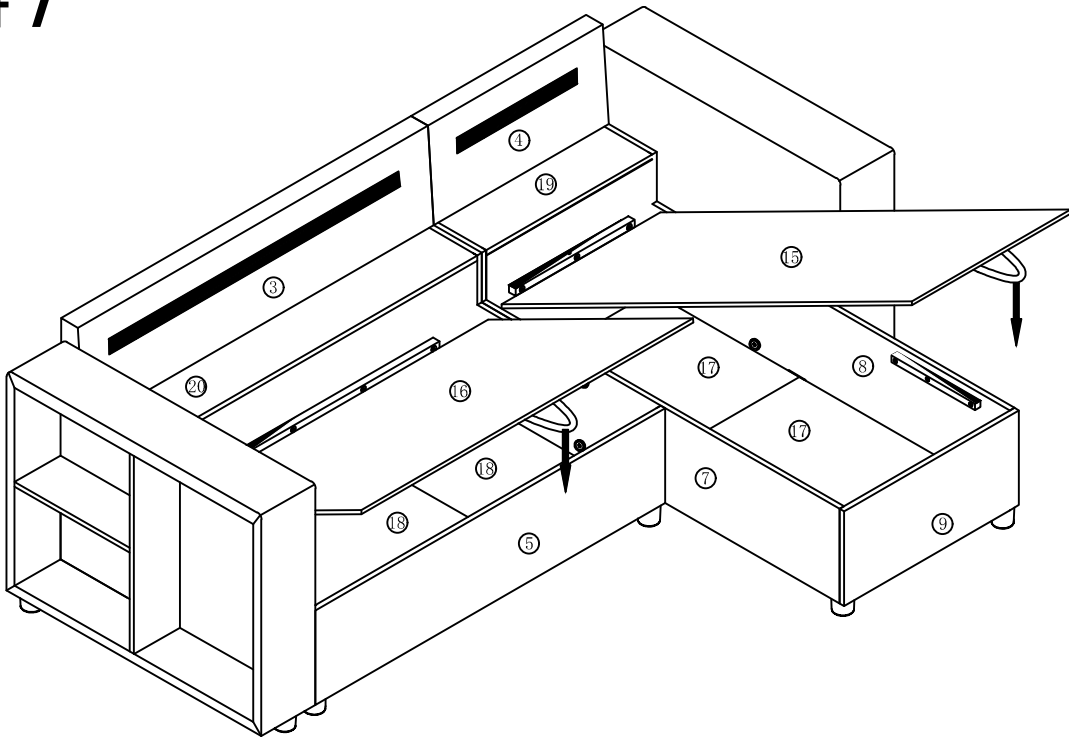

# 48

DE: Riss alle Stoffstreifen von den Teilen 3, 4, 15 und 16 ab.  
EN: Tear off all the fabric strips on components No. 3, 4, 15 and 16.  
FR: Retirez tous les bandes de tissu des pièces 3, 4, 15 et 16.  
IT: Scolpi tutti i listelli di tessuto sui componenti n. 3, 4, 15 e 16.  
ES: Despegue todas las tiras de tela de los componentes números 3, 4, 15 y 16.

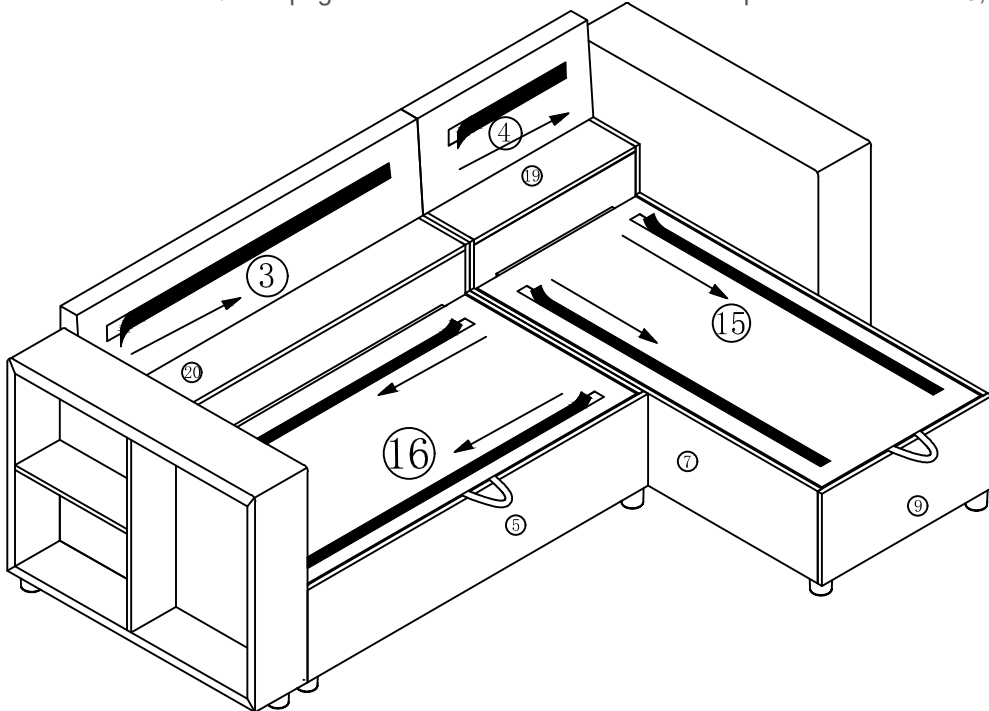

49

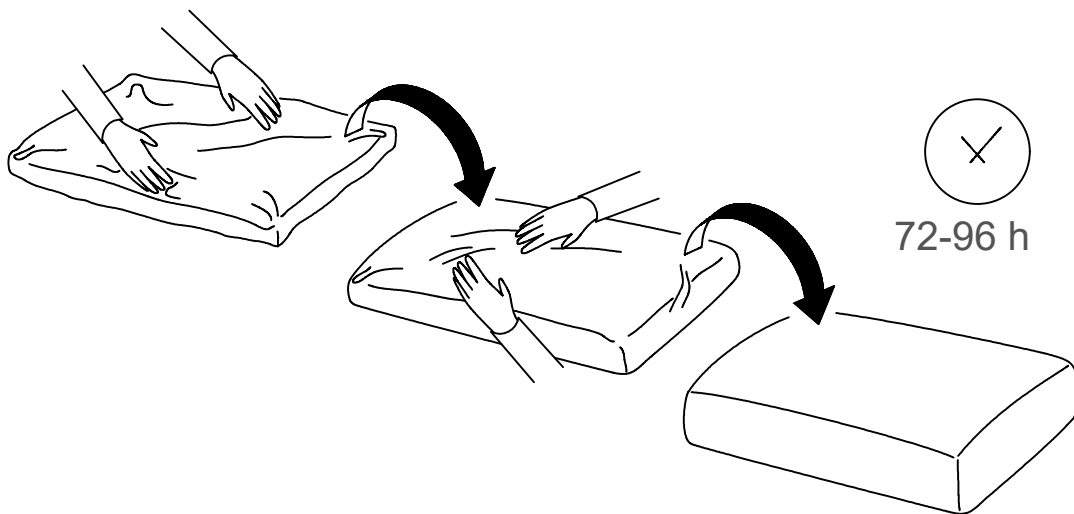
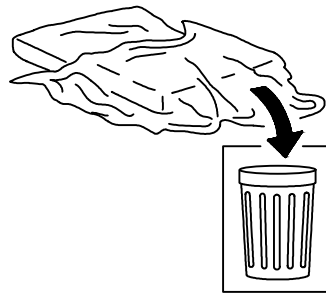
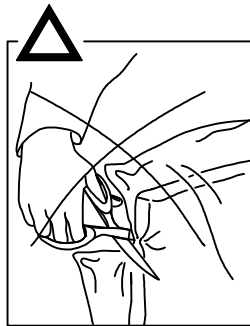
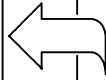
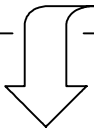
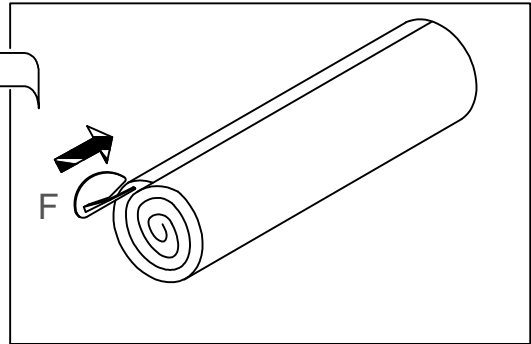
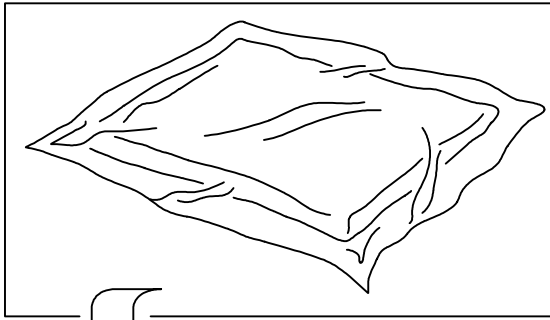

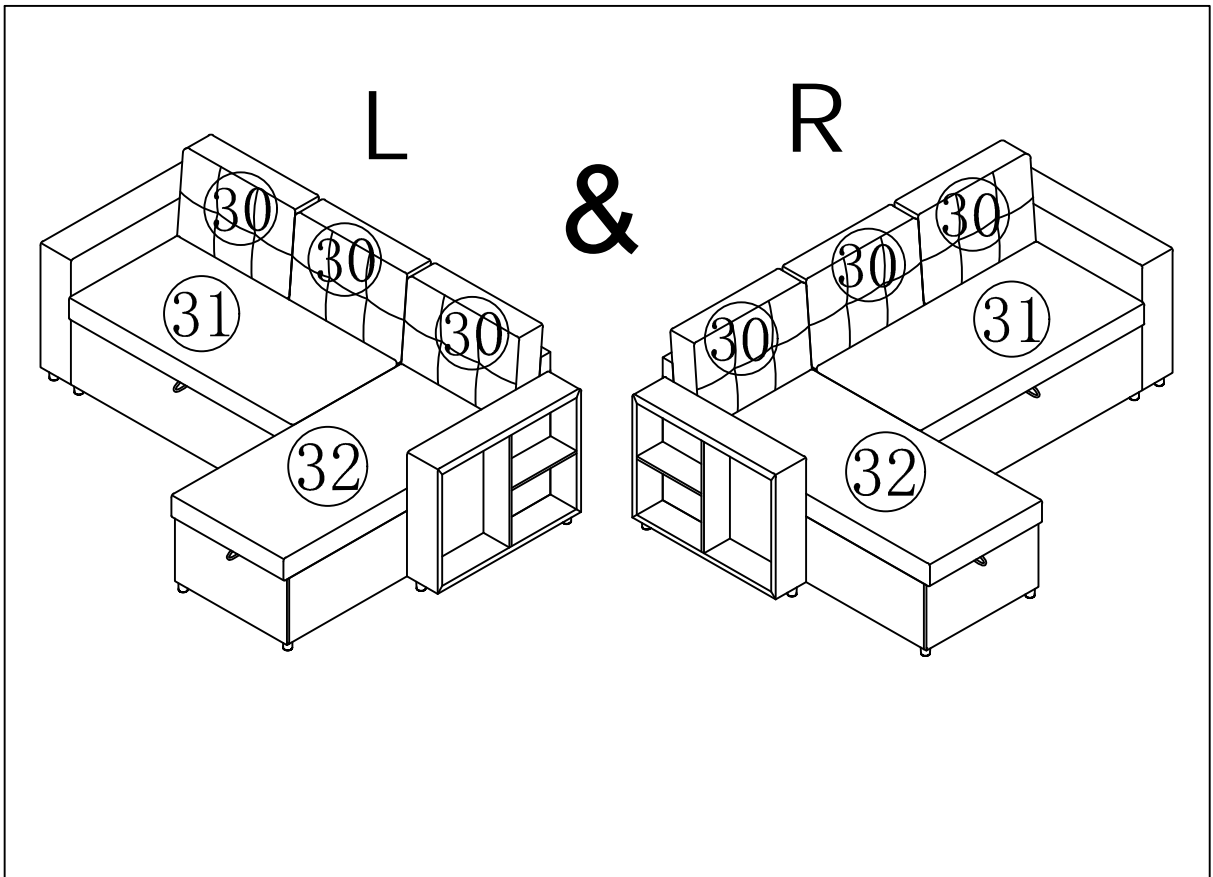
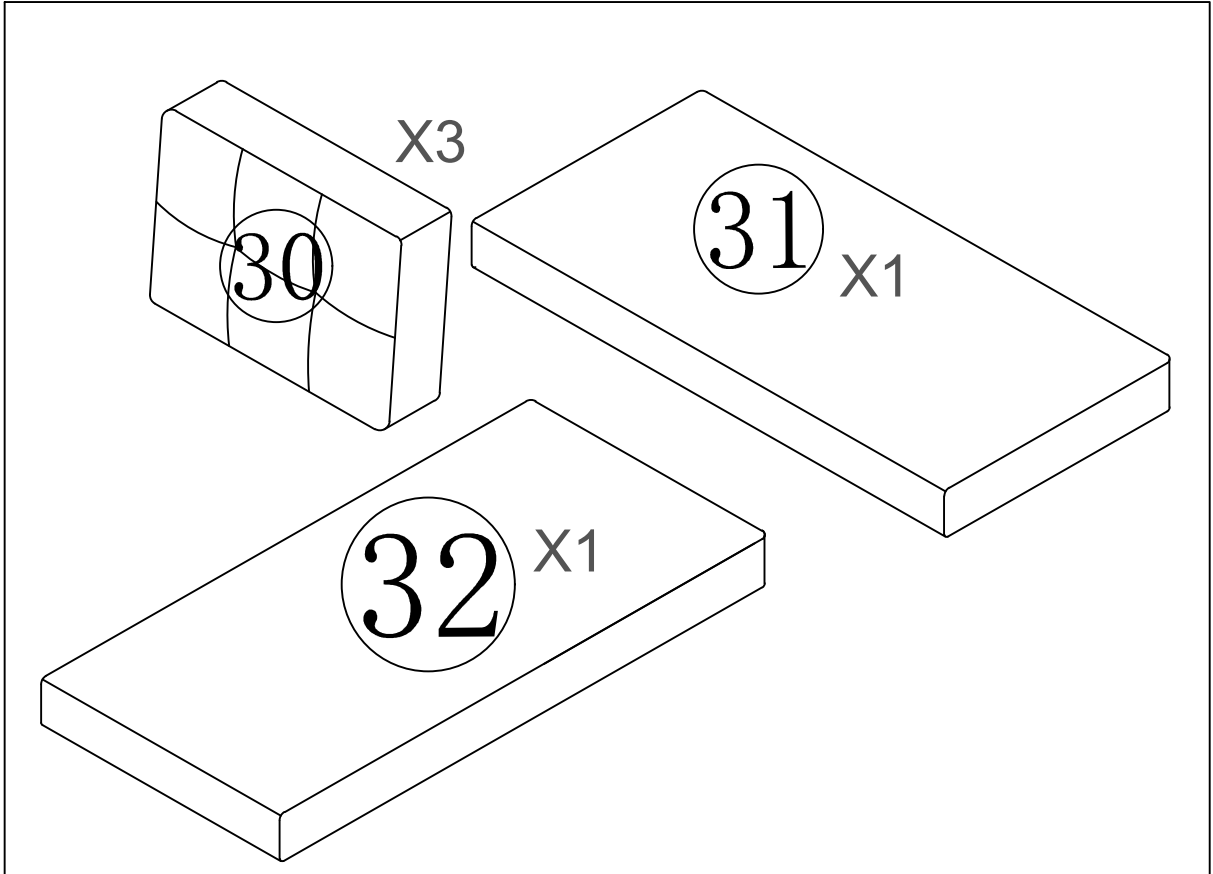

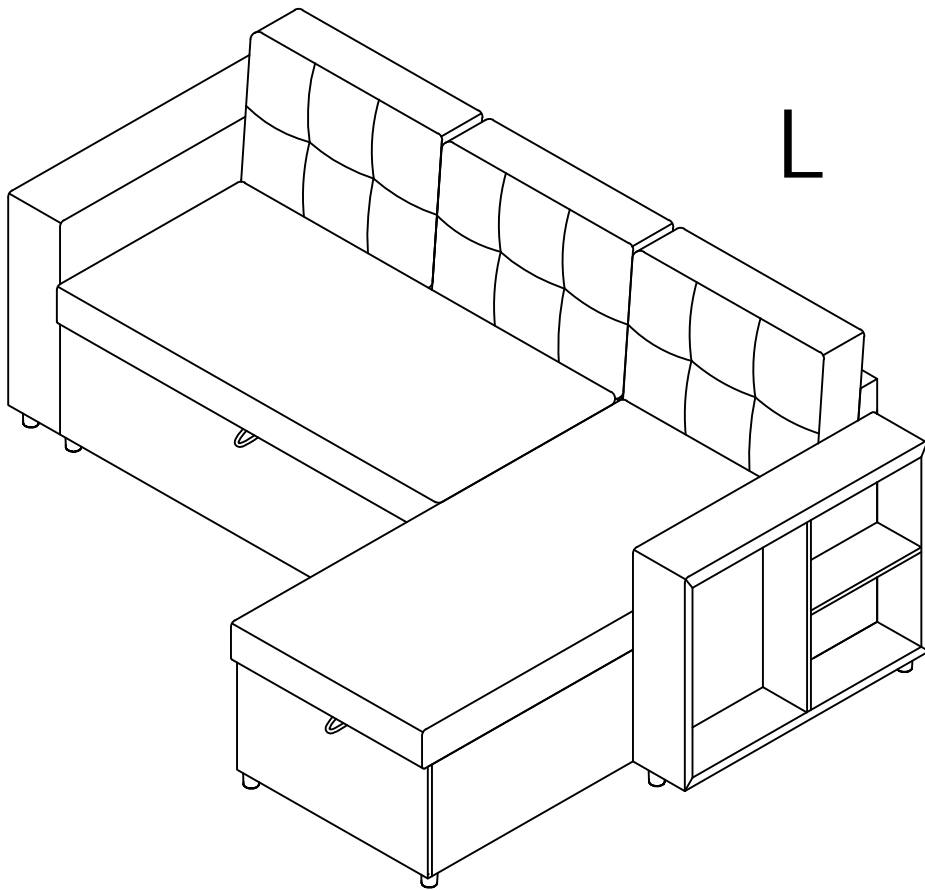

& R

