

DE: Installationsanleitung
EN: installation instructions
FR: Instructions d'installation
IT: Istruzioni per l'installazione
ES: Instrucciones de instalación

SKU NUMBER:N625P451549/N625P451550/N625P451551

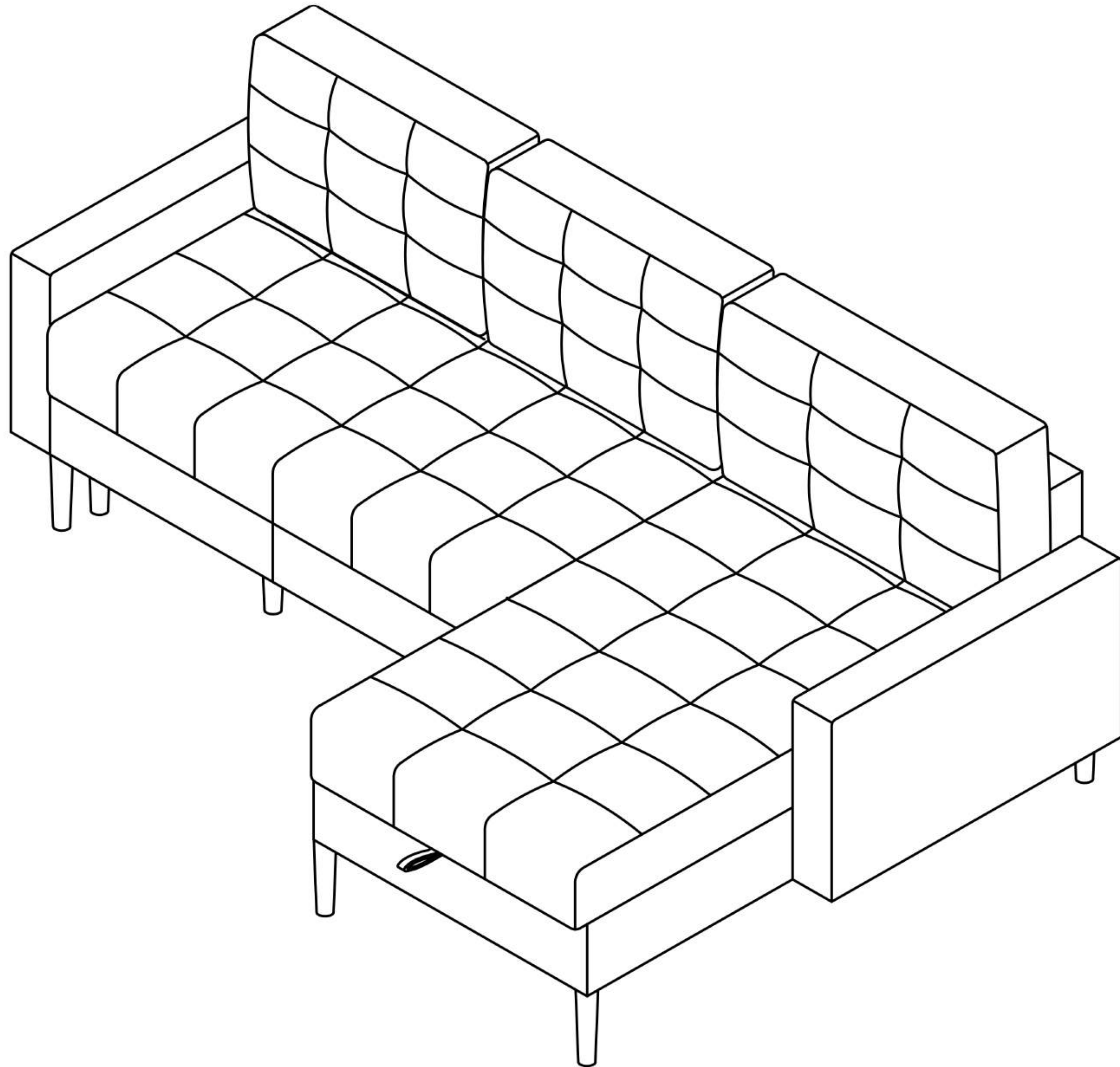

DE: Unsere Produkte werden in drei Pakete verteilt geliefert. Die Lieferzeit der drei Pakete kann unterschiedlich sein. Bitte haben Sie Geduld. Vielen Dank für Ihr Verständnis!

EN: Our products will be delivered in three packages. The delivery times for these three packages may vary. Please be patient and wait. Thank you for your understanding!

FR: Nos produits seront livrés en trois colis. Le délai de livraison pour ces trois colis peut différer. Veuillez patienter. Merci de votre compréhension !

IT: I nostri prodotti verranno spediti in tre pacchi separati. I tempi di consegna per i tre pacchi potrebbero essere diversi. Si prega di attendere con pazienza. Grazie per la comprensione!

ES: Nuestros productos se enviarán en tres paquetes diferentes, los cuales podrían llegar en momentos distintos. Por favor, tenga paciencia. ¡Gracias por su comprensión!

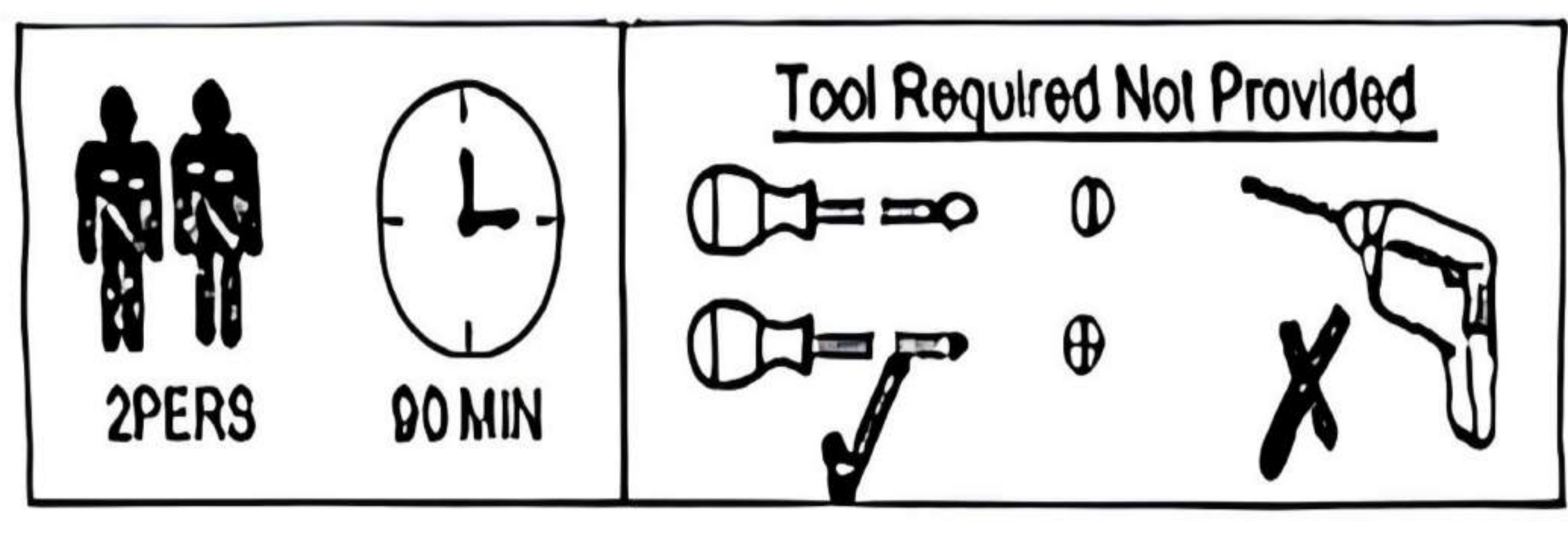

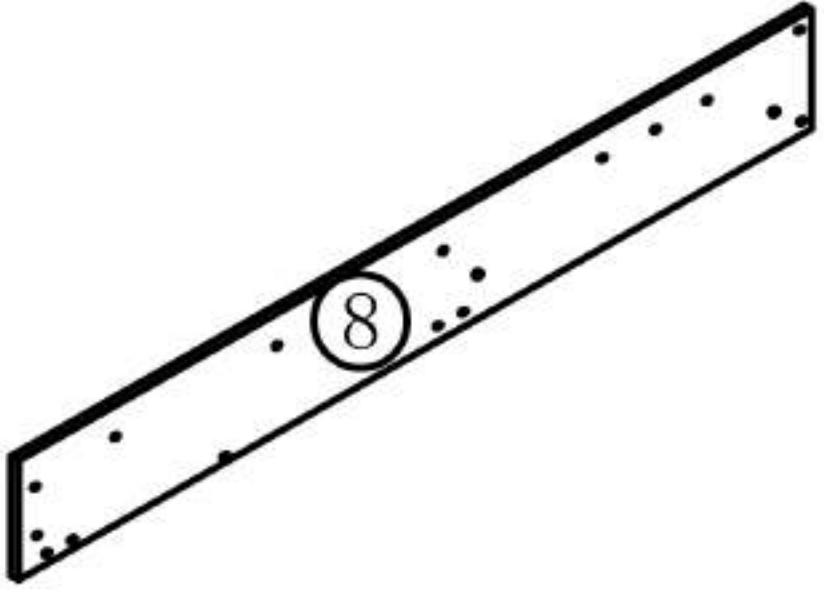
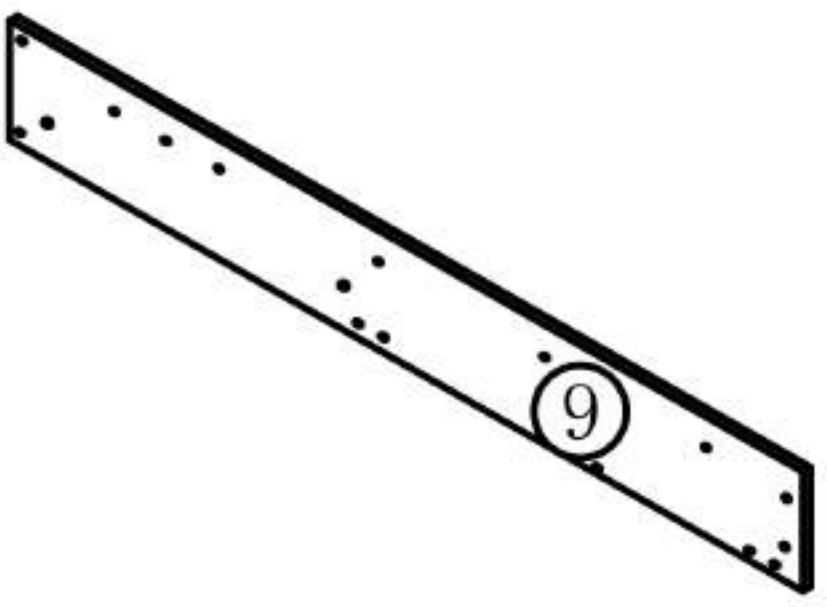
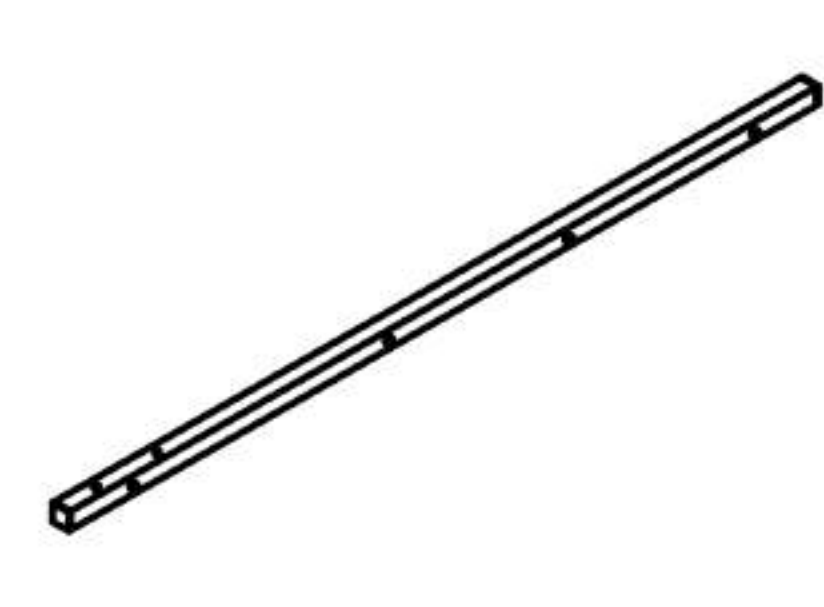
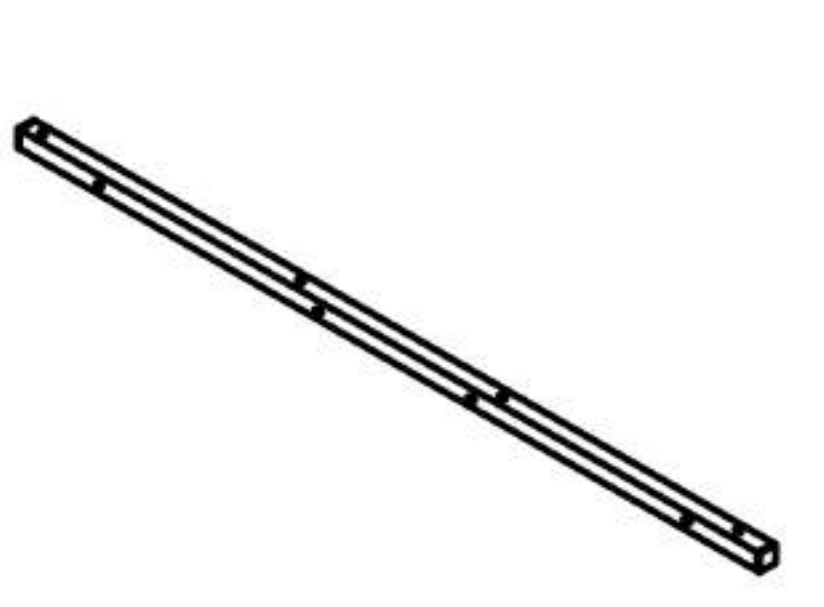
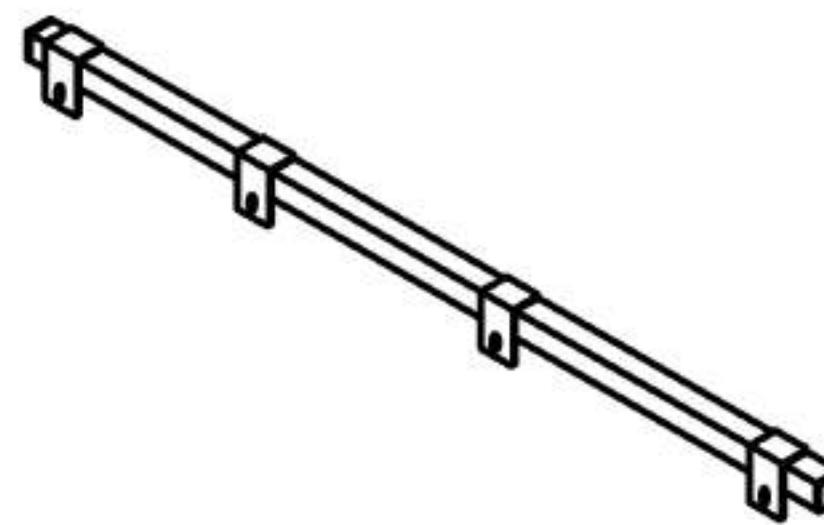
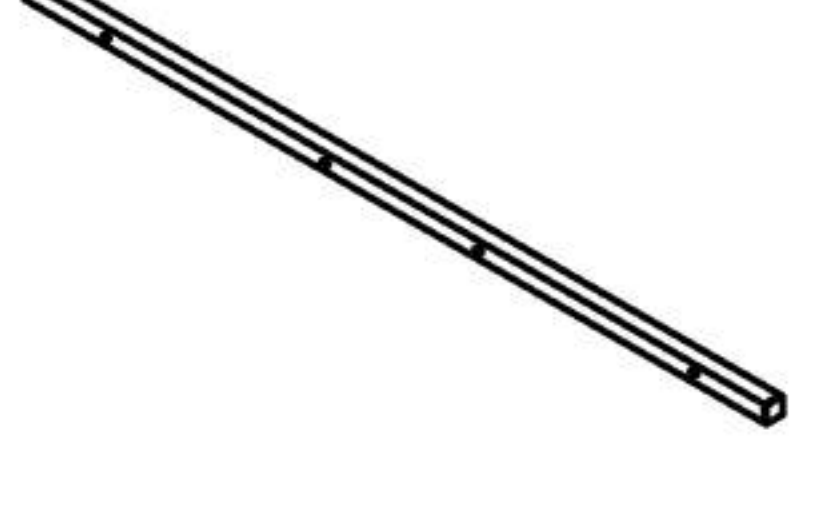
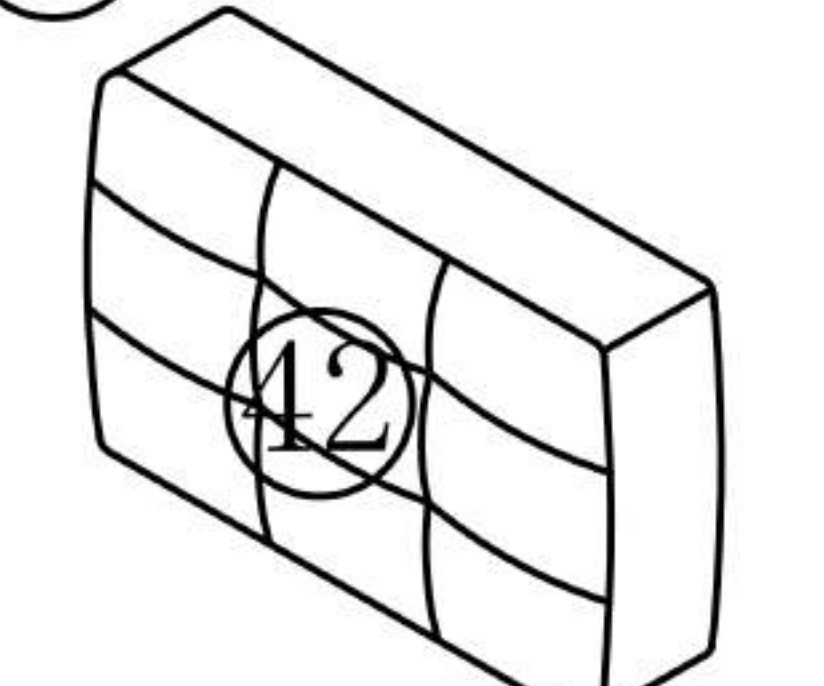
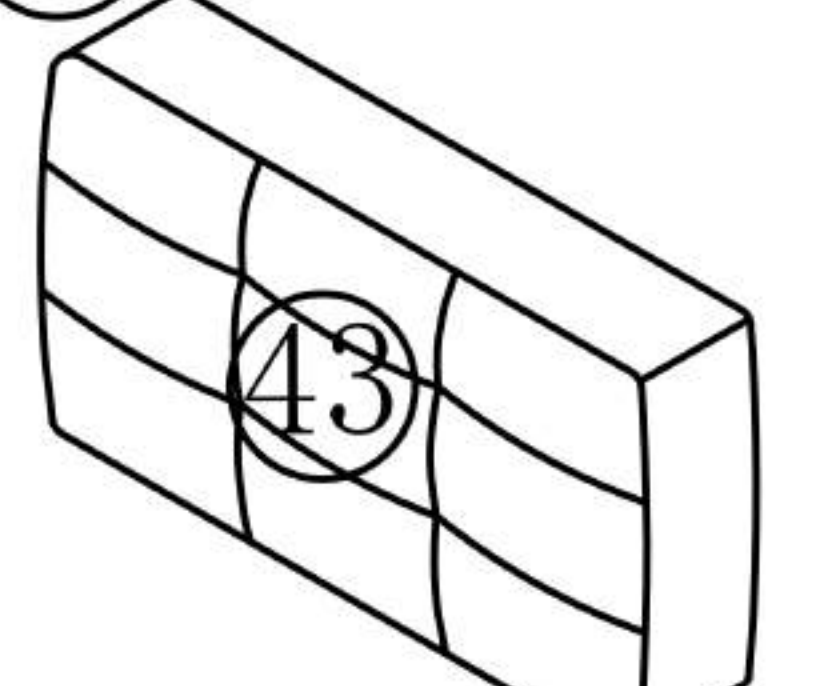
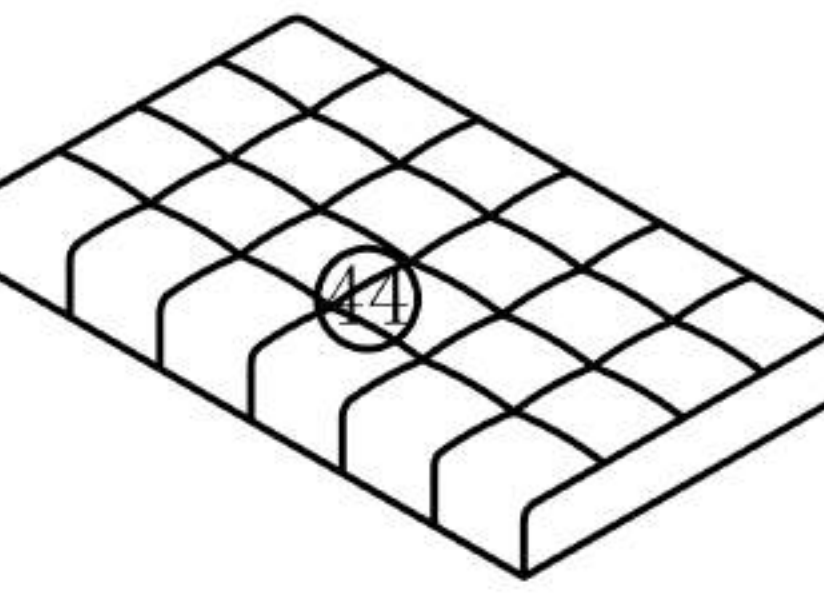
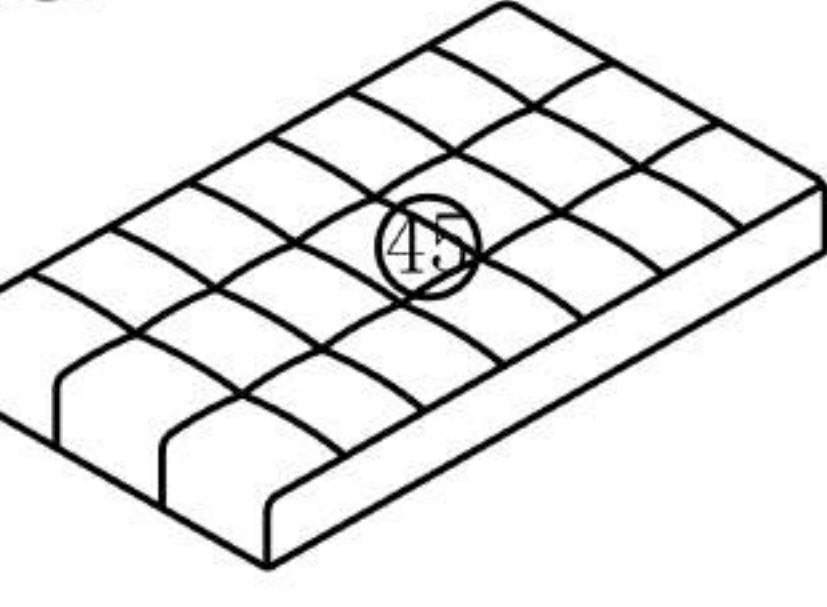
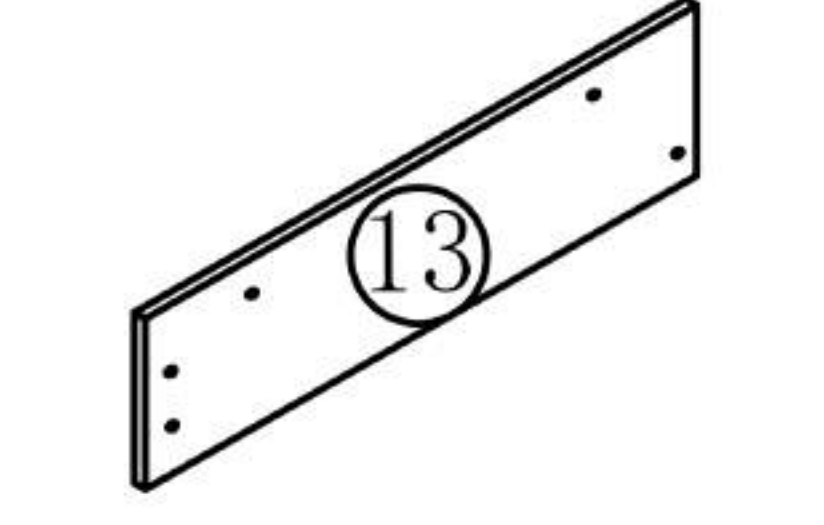
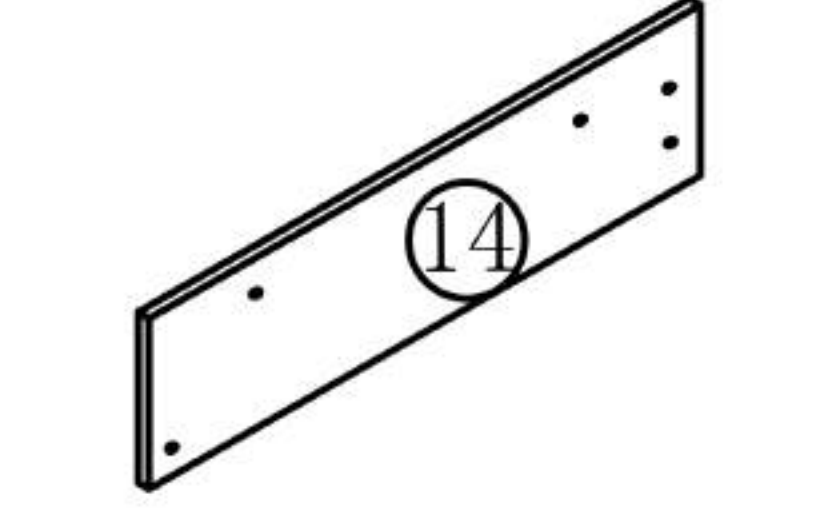

TELLE

N625P451549

<p>⑧ x1</p> 	<p>⑨ x1</p> 	<p>⑱ x2</p> 	<p>⑳ x1</p> 
<p>㉑ x1</p> 	<p>⑳ x1</p> 	<p>㉒ x2</p> 	<p>㉓ x1</p> 
<p>㉔ x1</p> 	<p>㉕ x1</p> 	<p>⑬ x1</p> 	<p>⑭ x1</p> 



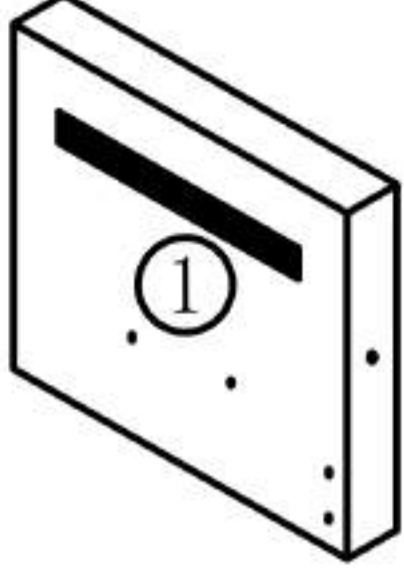
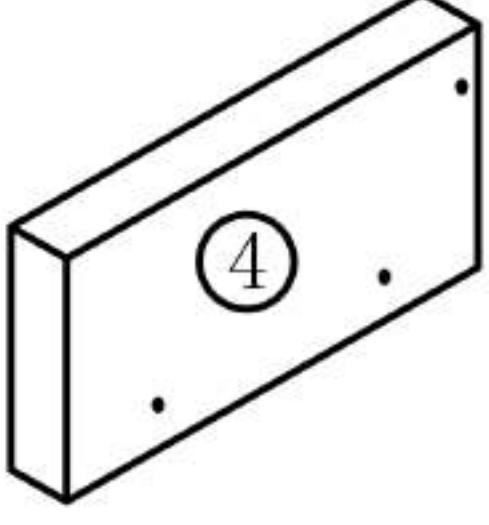
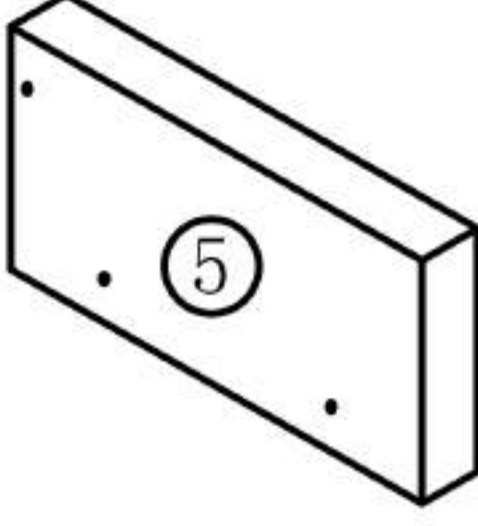

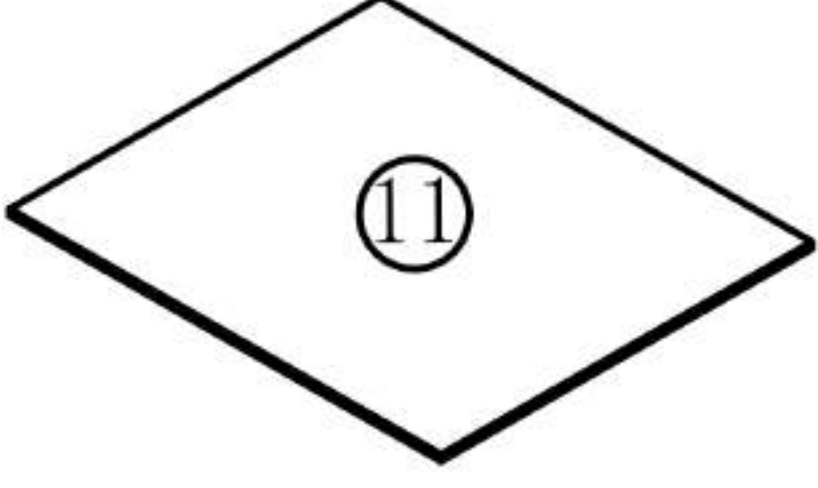
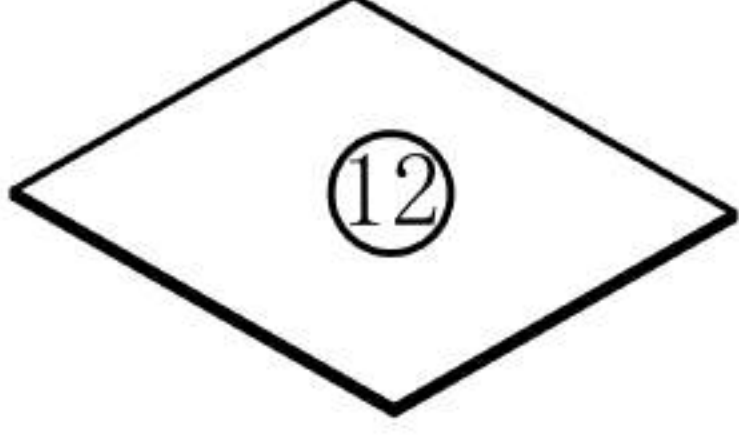
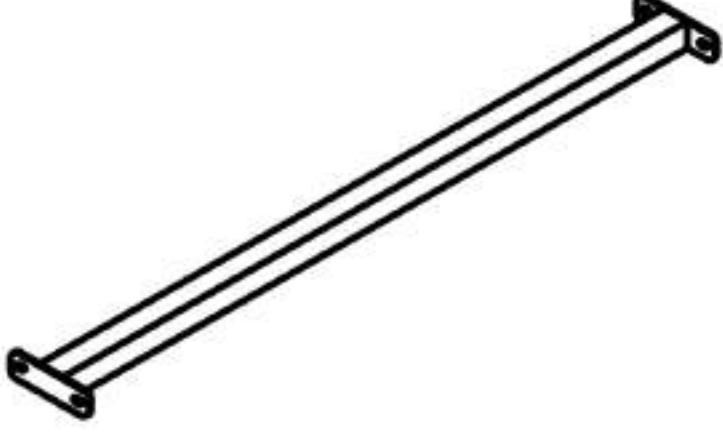





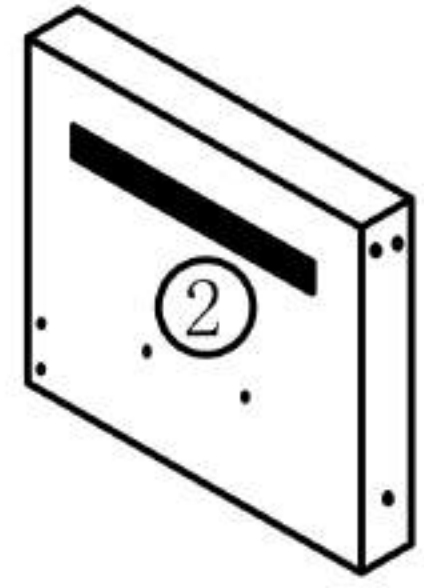
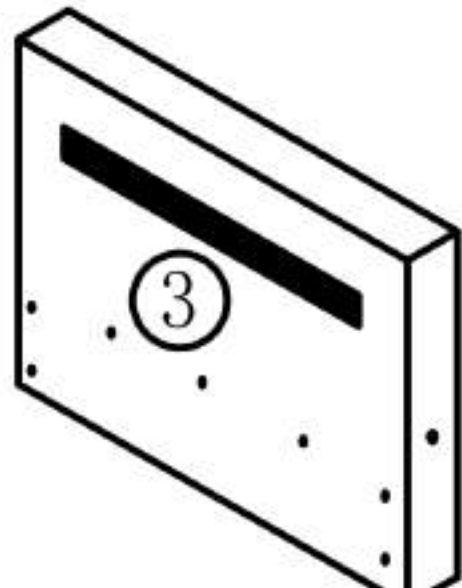
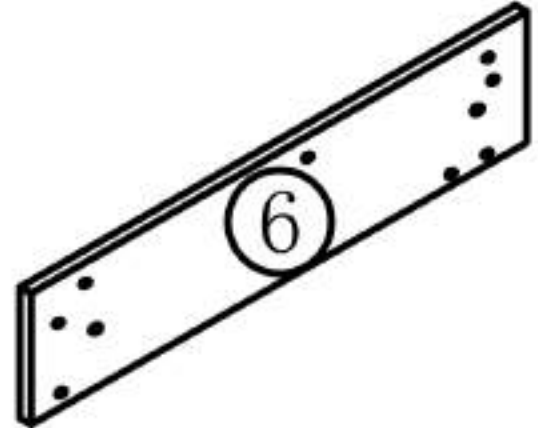
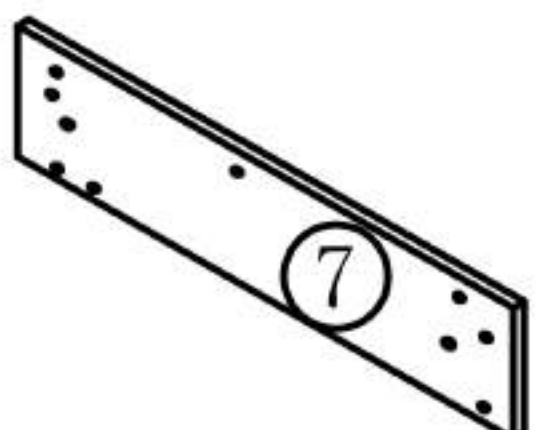
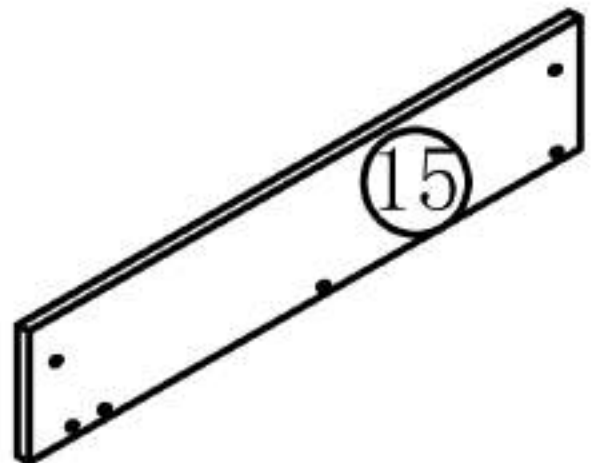
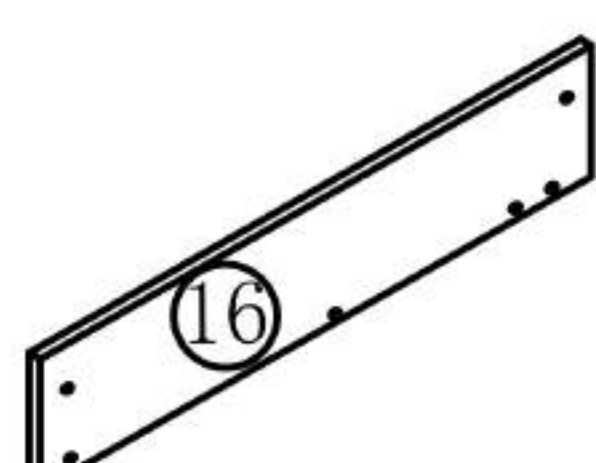

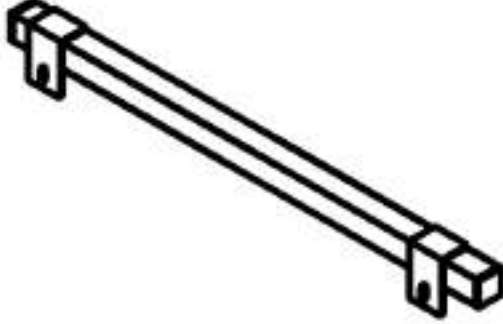

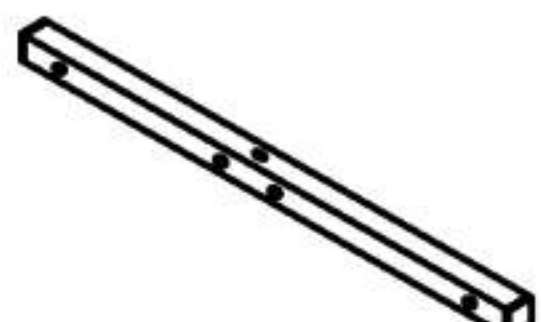
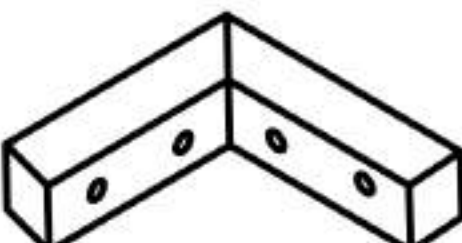
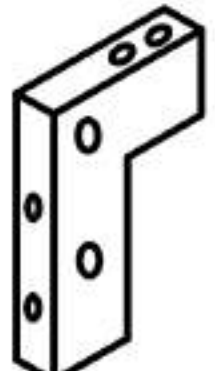
TELLE

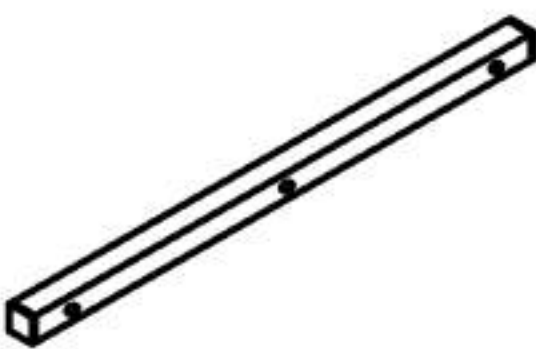
N625P451550

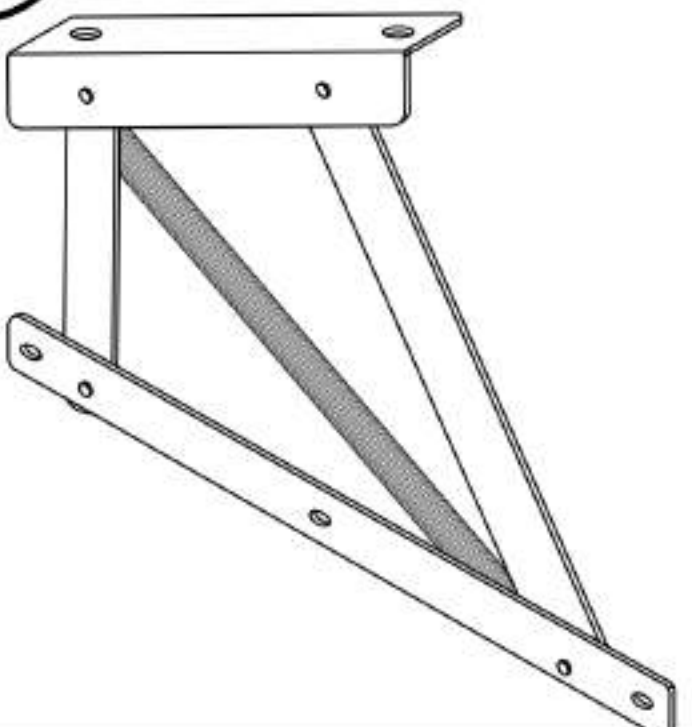
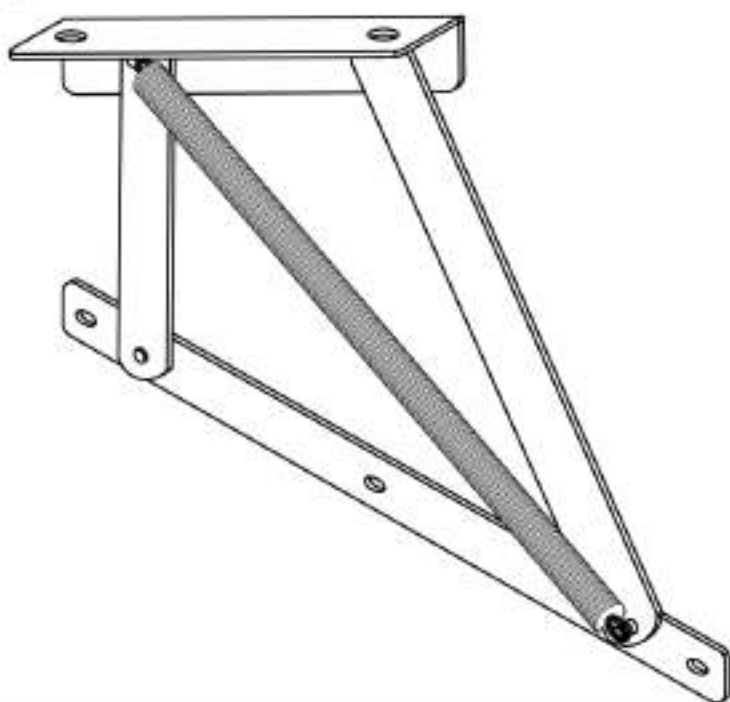
<p>① x1</p> 	<p>④ x1</p> 	<p>⑤ x1</p> 	<p>②⑨ x1</p> 
<p>①① x2</p> 	<p>①② x2</p> 	<p>①⑨ x1</p> 	

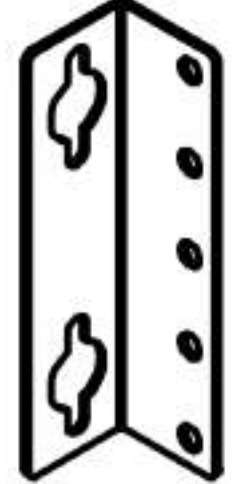
TELLE

N625P451551







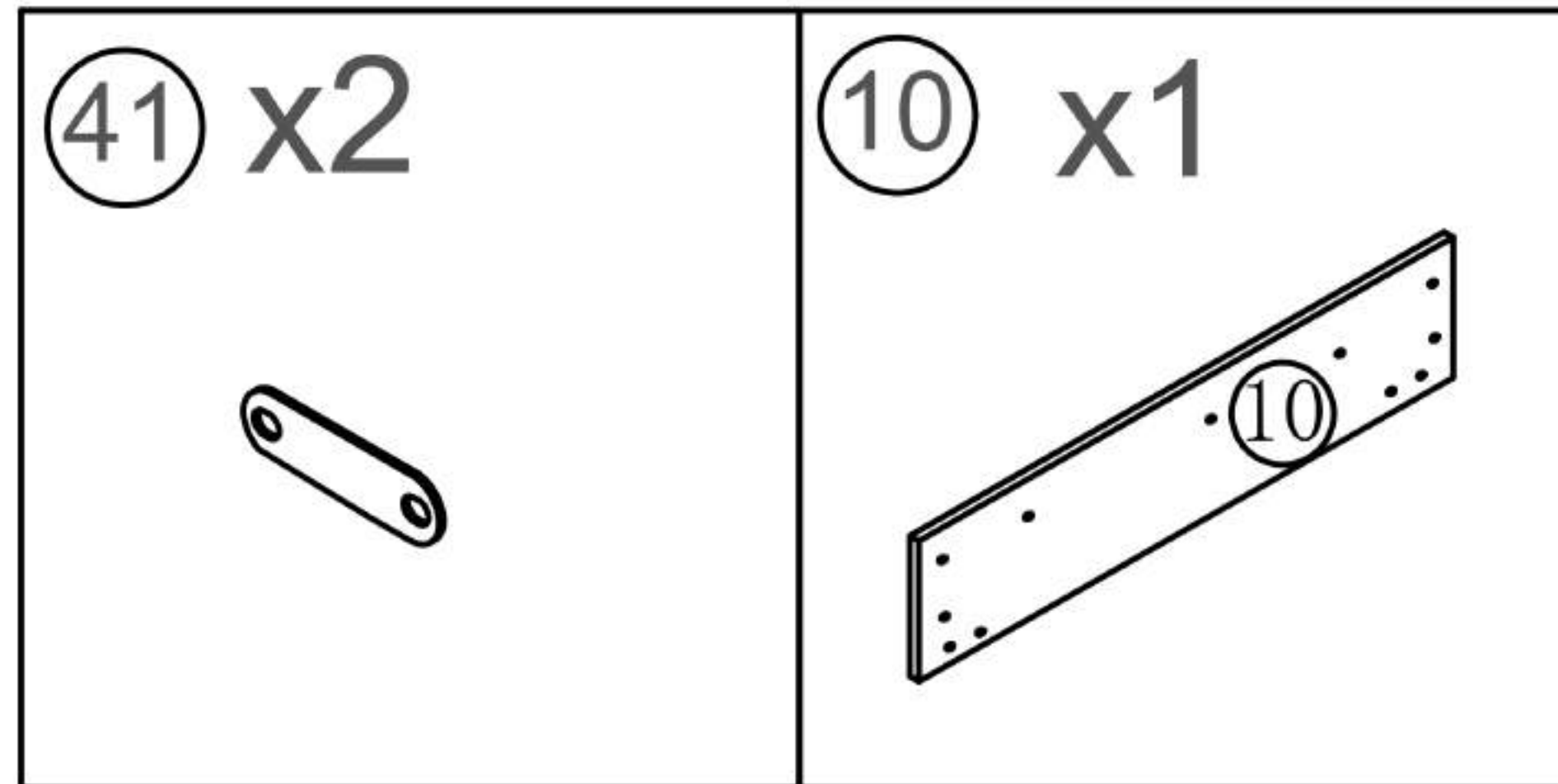

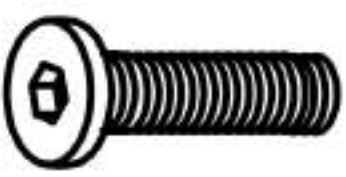

② x1 	③ x1 	⑥ x1 	⑦ x1 
⑮ x1 	⑯ x1 	⑰ x2 	⑳ x1 
㉓ x4 	㉔ x1 	㉕ x4 	㉖ x2 
㉗ x2 	㉘ x1 	㉛ x2 	㉜ x2 
㉞ x1 	㉟ x1 	㉡ x2 	㉢ x2 
㉣ x11 	㉤ x2 	㉥ x2 	㉦ x2 

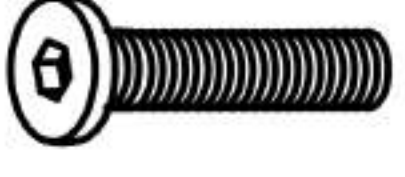
TELLE

N625P451551

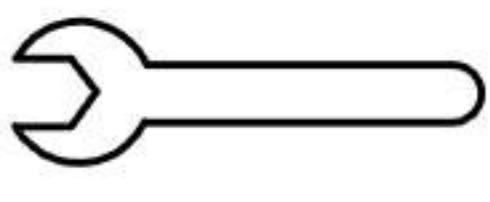

Hardware List-Hardwareliste N625P451551

<p>A x42</p>  <p>M8*16</p>	<p>B x50</p>  <p>M8*37</p>	<p>C x28</p>  <p>M8*45</p>	<p>D x8</p>  <p>M8*55</p>
<p>E x4</p>  <p>M6*20</p>	<p>F x6</p>  <p>M6*20</p>	<p>G x6</p>  <p>M8</p>	<p>H x22</p>  <p>Ø8x22 mm</p>
<p>I x1</p>  <p>Letter Opener</p>	<p>J x1</p>  <p>M8 Spanner</p>	<p>K x1</p>  <p>S4</p>	<p>L x1</p>  <p>S5</p>

1

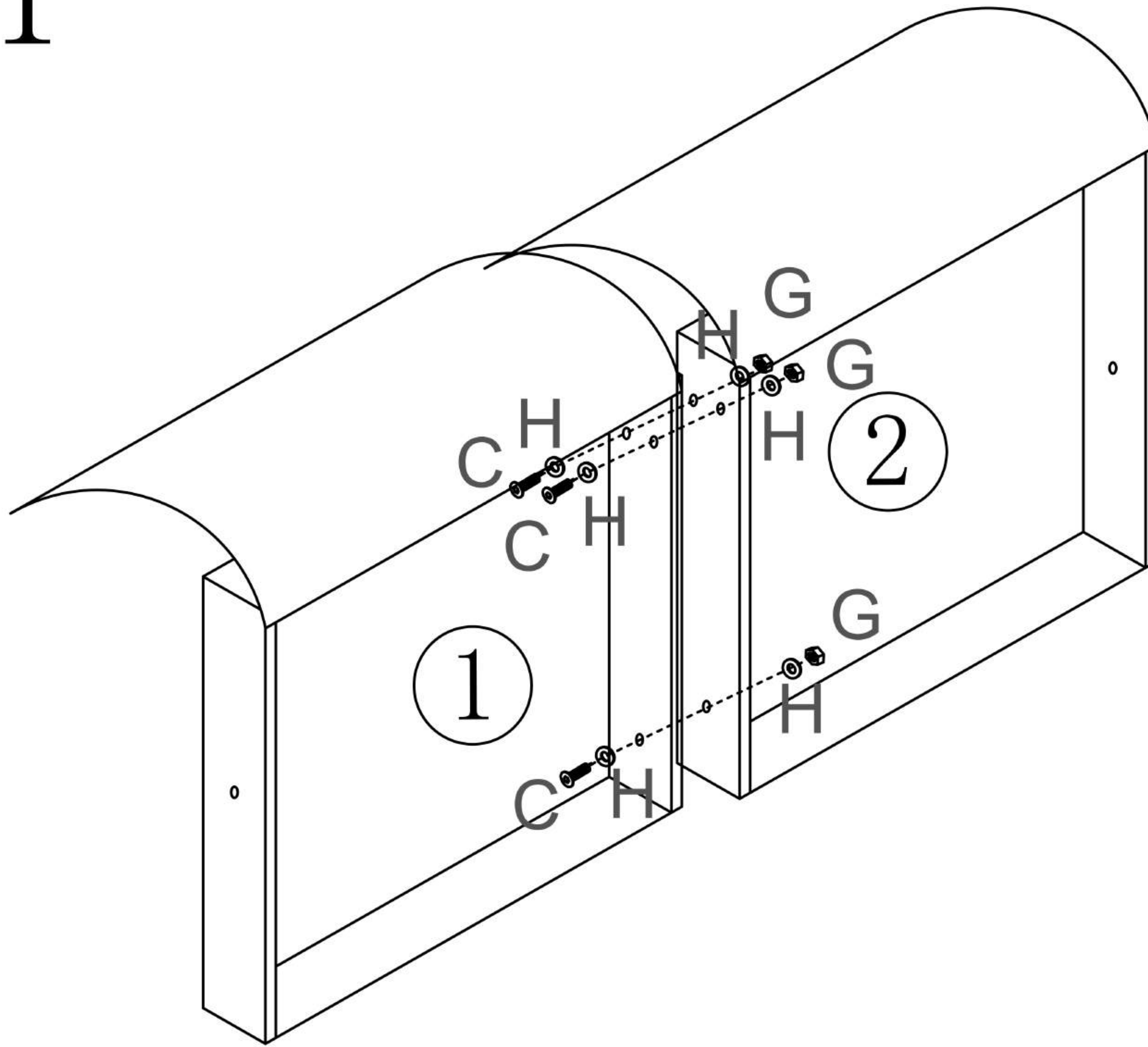

C M8*45



X3

G



X3

H



X6

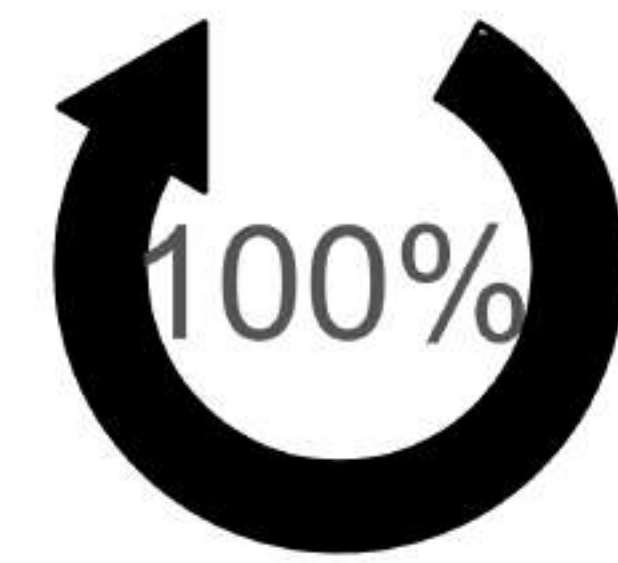

2

DE: Bitte montieren Sie die Seite mit dem Aufkleber oben.
EN: Please assemble the side with the sticker on top
FR: Veuillez assembler le côté avec l'autocollant sur le dessus.
IT: Si prega di assemblare il lato con la colla sopra.
ES: Por favor, ensamble el lado con la etiqueta en la parte superior.

B M8*37



X4

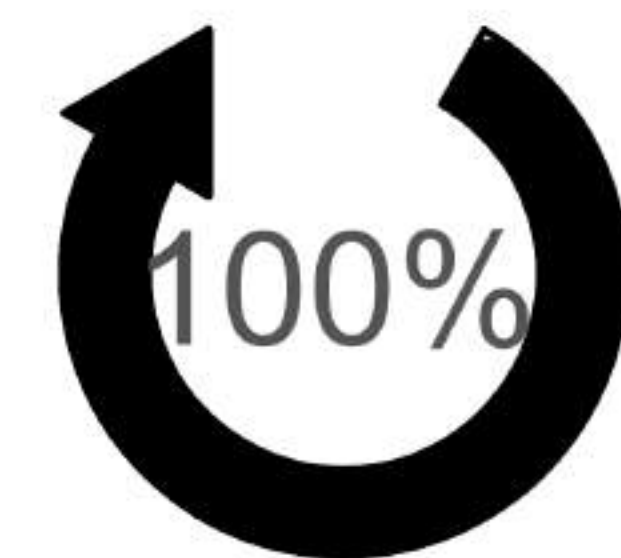
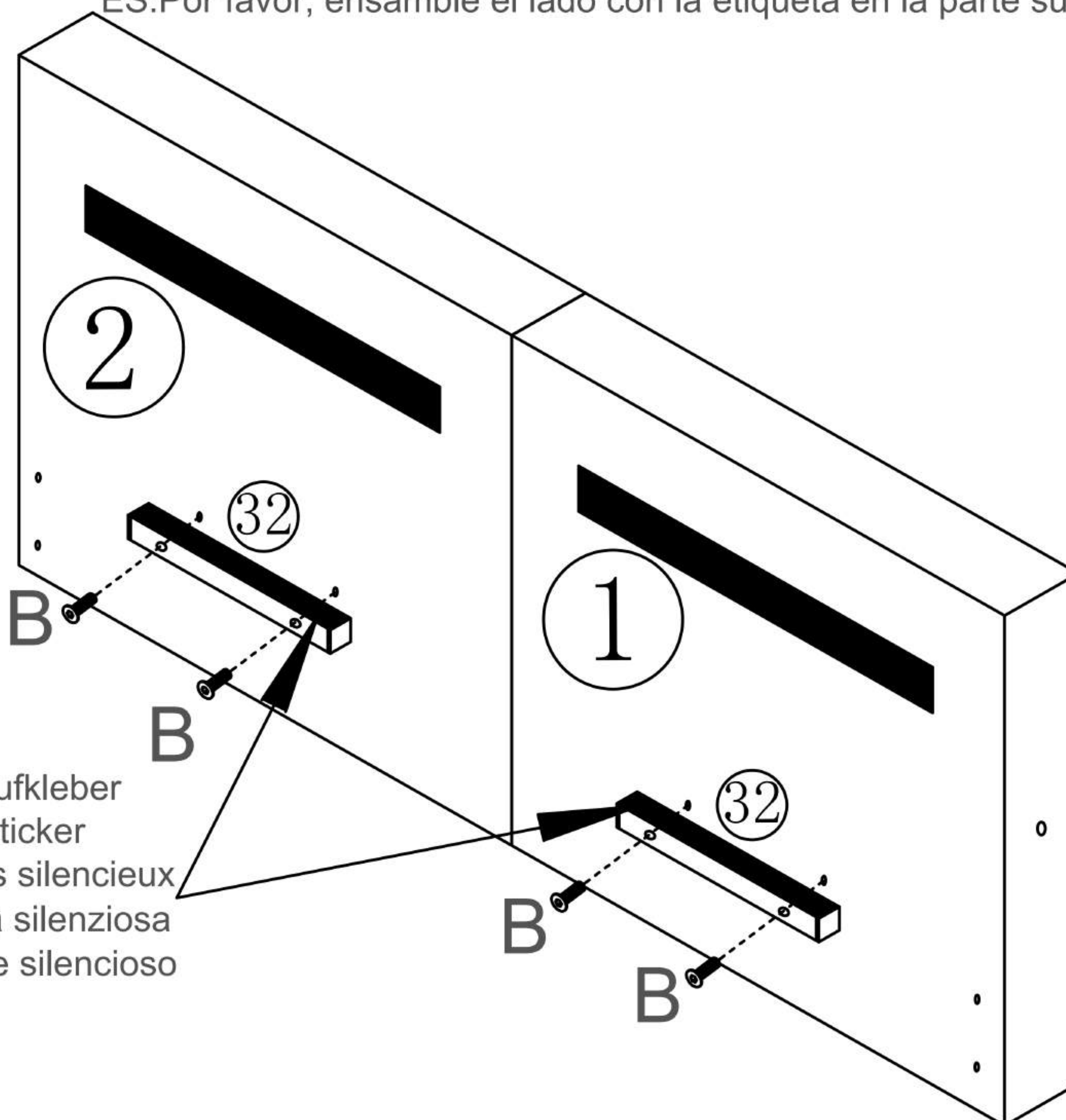

(DE): Stille Aufkleber
(EN): Silent sticker
(FR): Stickers silencieux
(IT): Etichetta silenziosa
(ES): Estuche silencioso

3

A M8*16

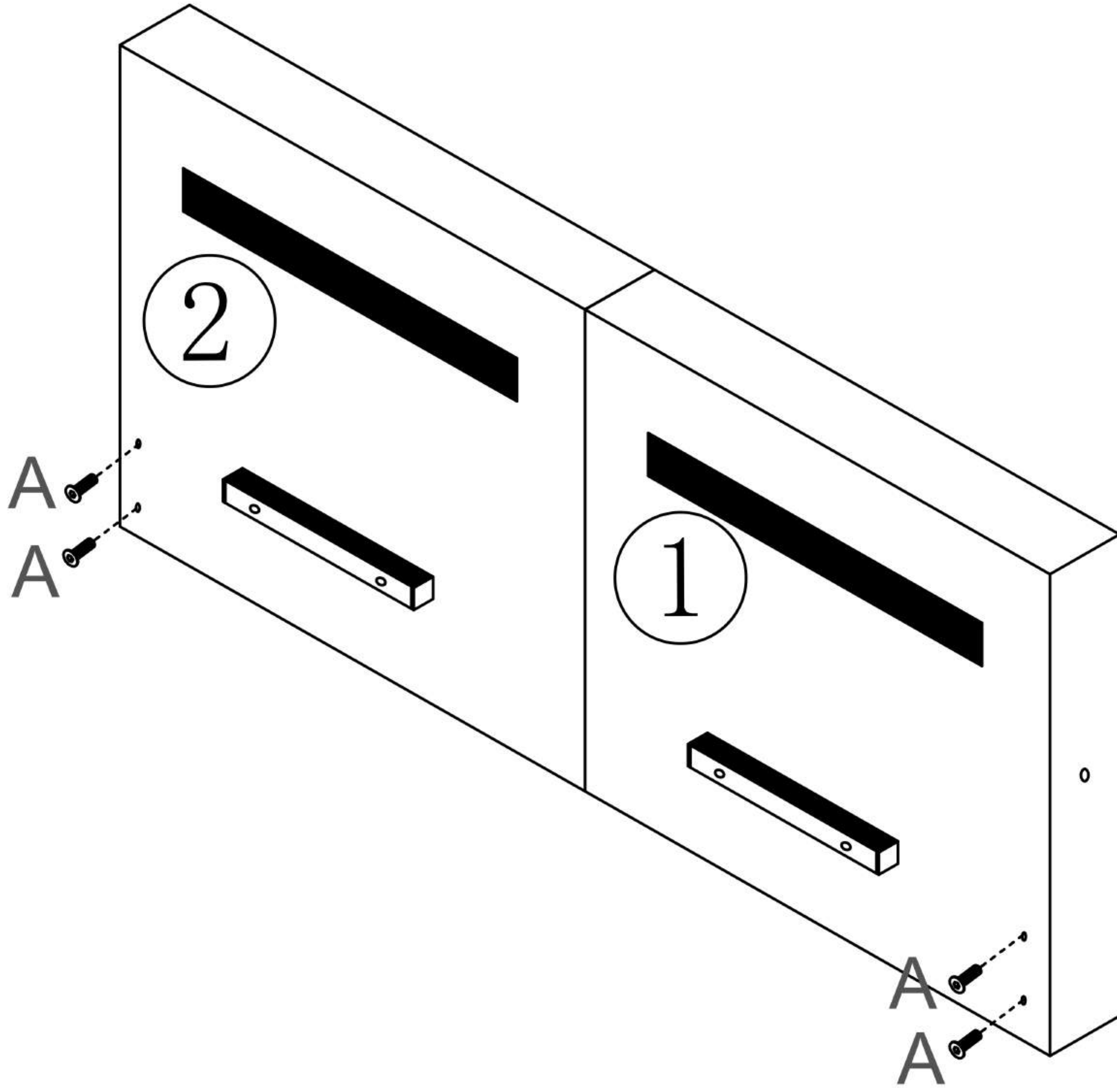

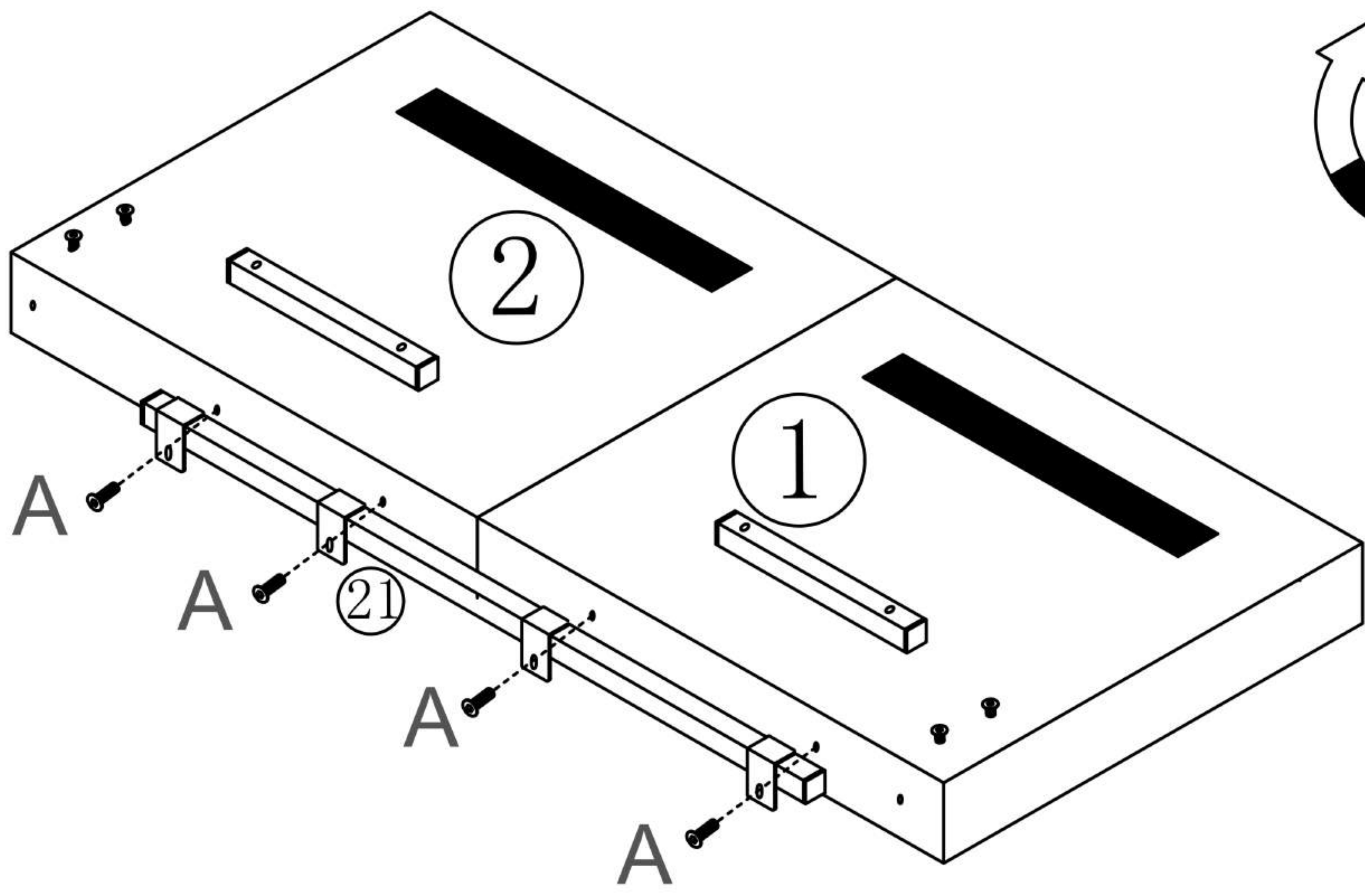

4

A M8*16



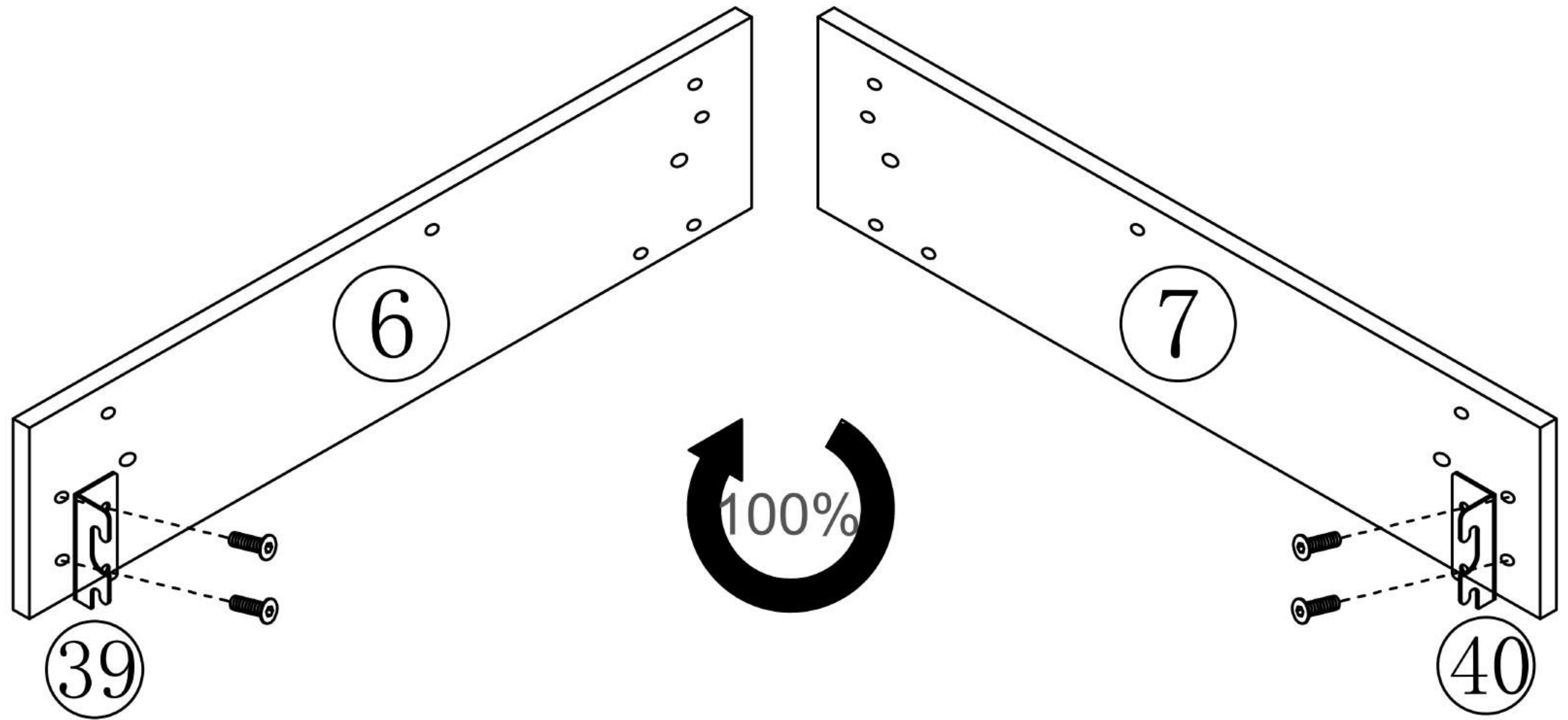

5

- | | | | | | |
|----|---|----|---------|---|----|
| 39 |  | X1 | A M8*16 |  | X4 |
| 40 |  | 1 | | | |

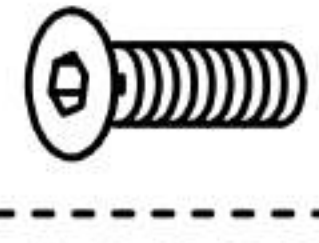

6

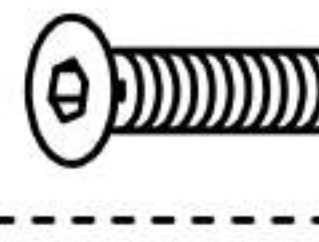
- | | | | | | |
|----|---|----|---------|---|----|
| 35 |  | X2 | A M8*16 |  | X4 |
| 41 |  | X1 | B M8*37 |  | X4 |

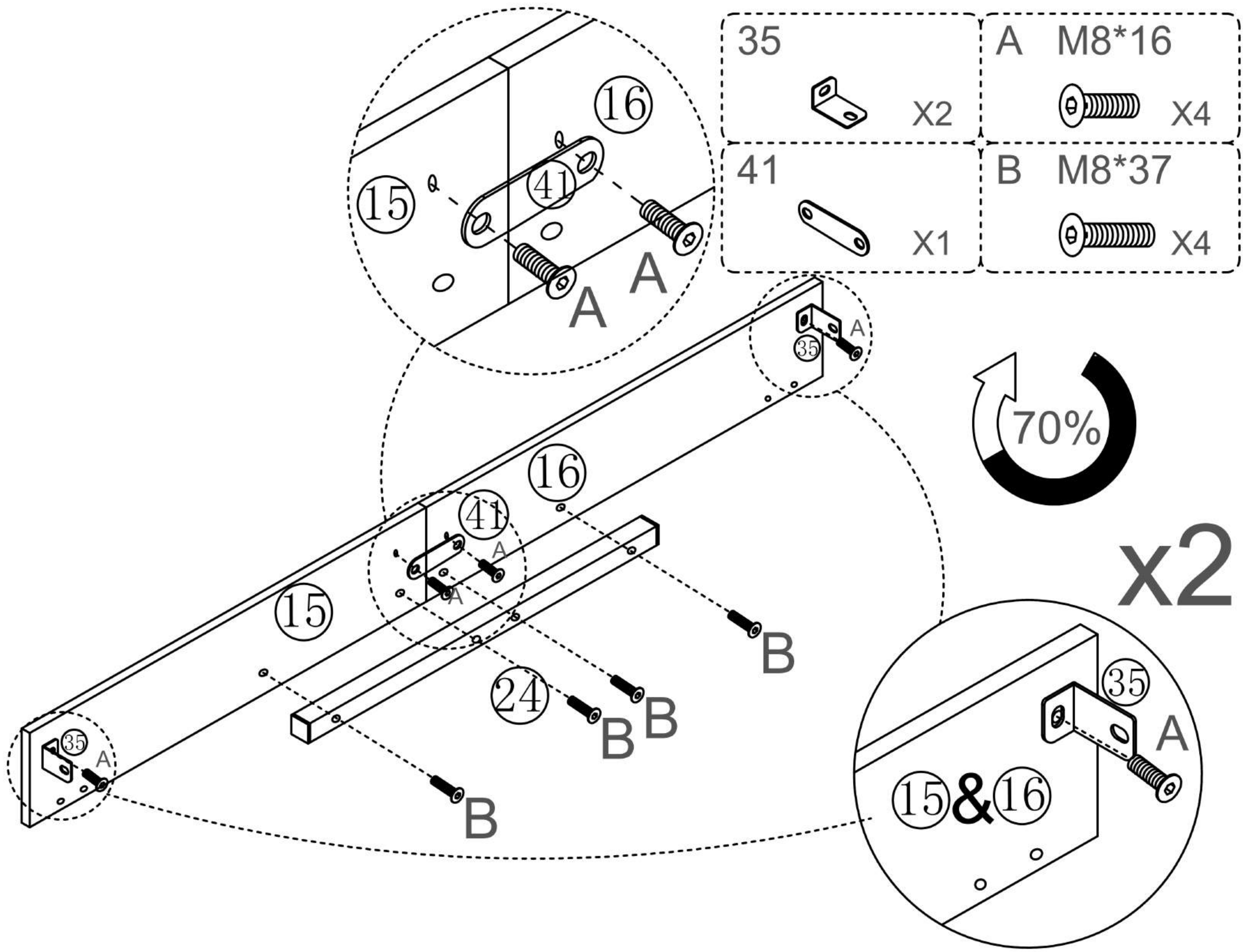

7

A M8*16
 X2

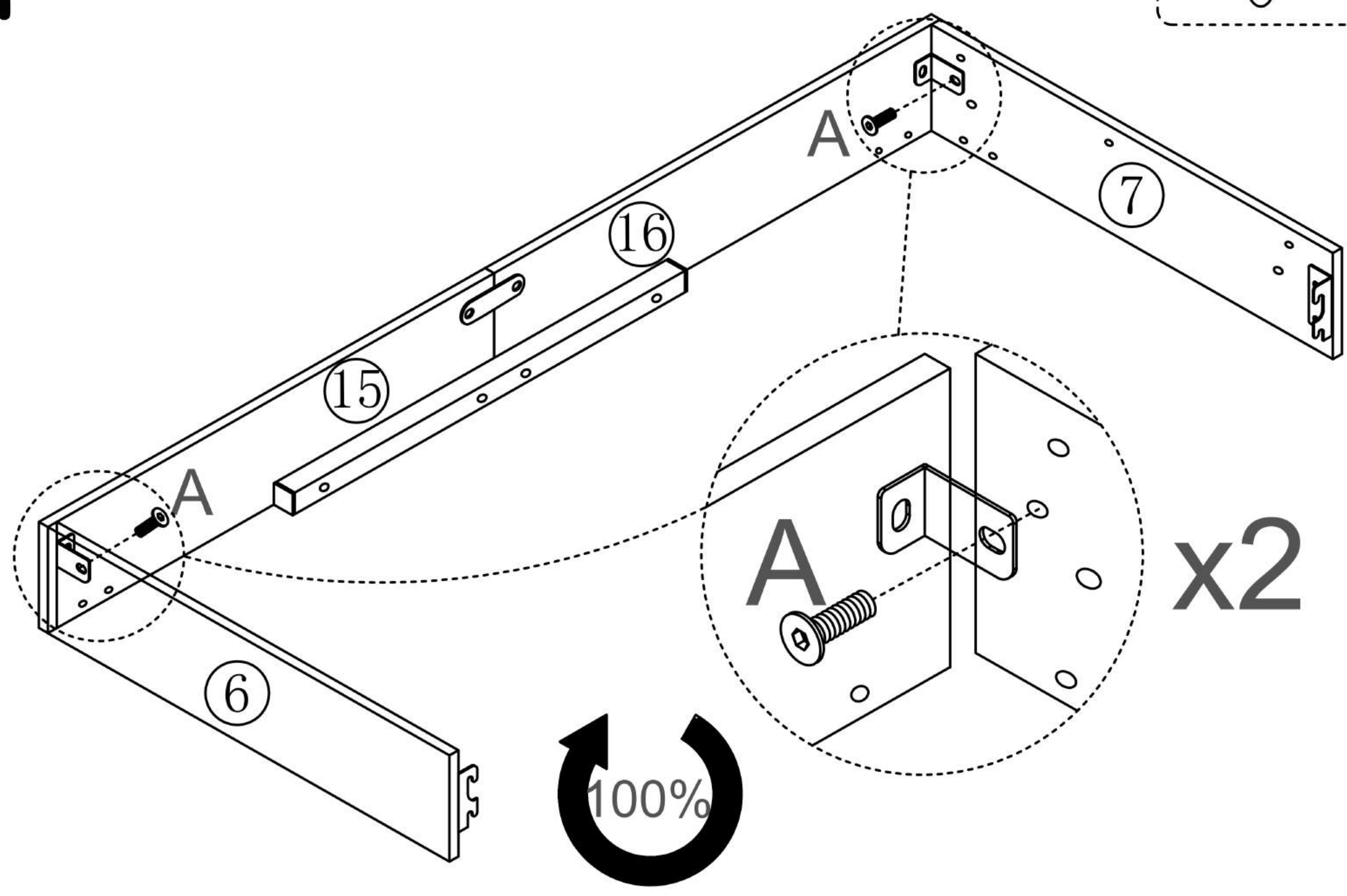

8

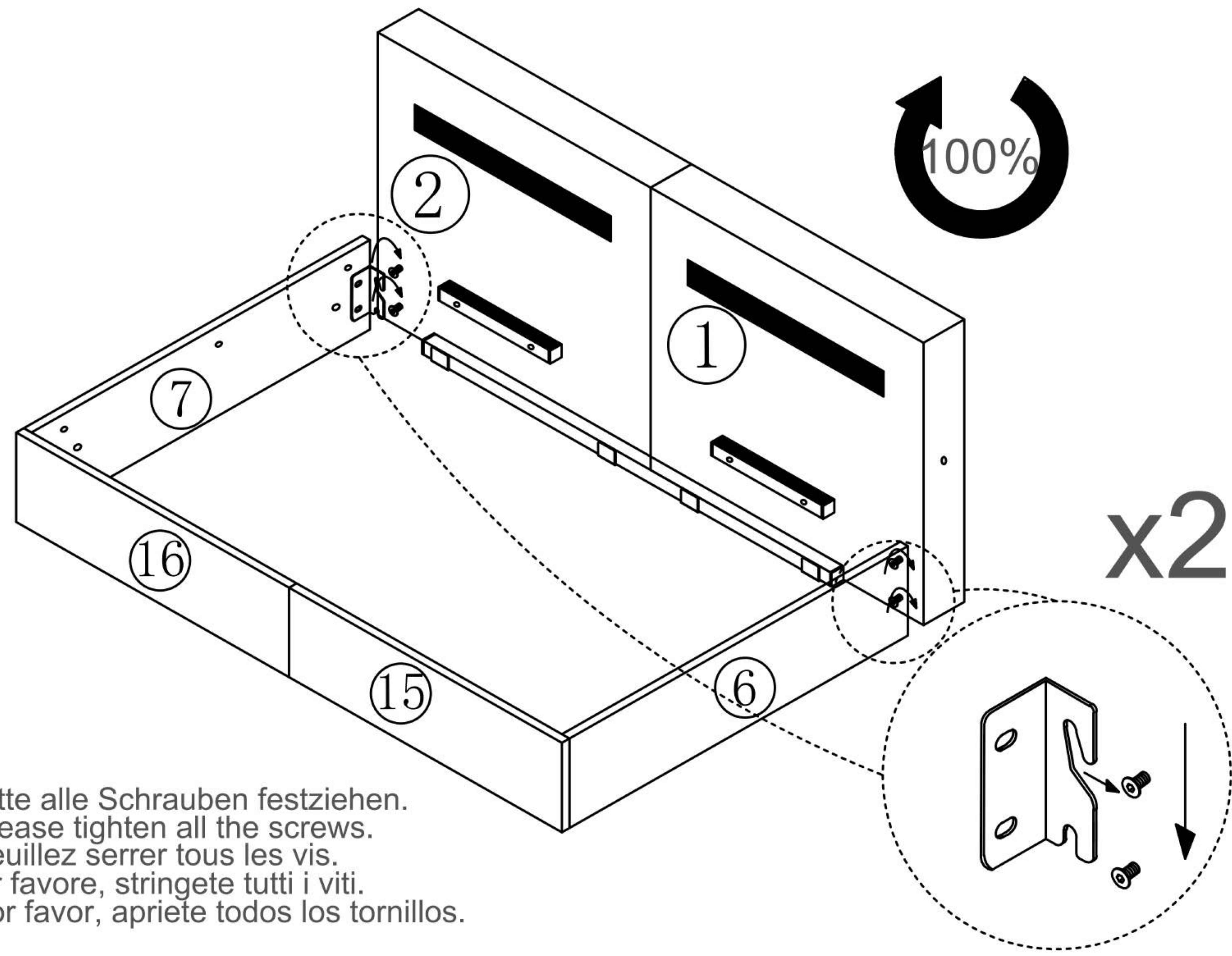

DE: Bitte alle Schrauben festziehen.
 EN: Please tighten all the screws.
 FR: Veuillez serrer tous les vis.
 IT: Per favore, stringete tutti i viti.
 ES: Por favor, apriete todos los tornillos.

9

B M8*37

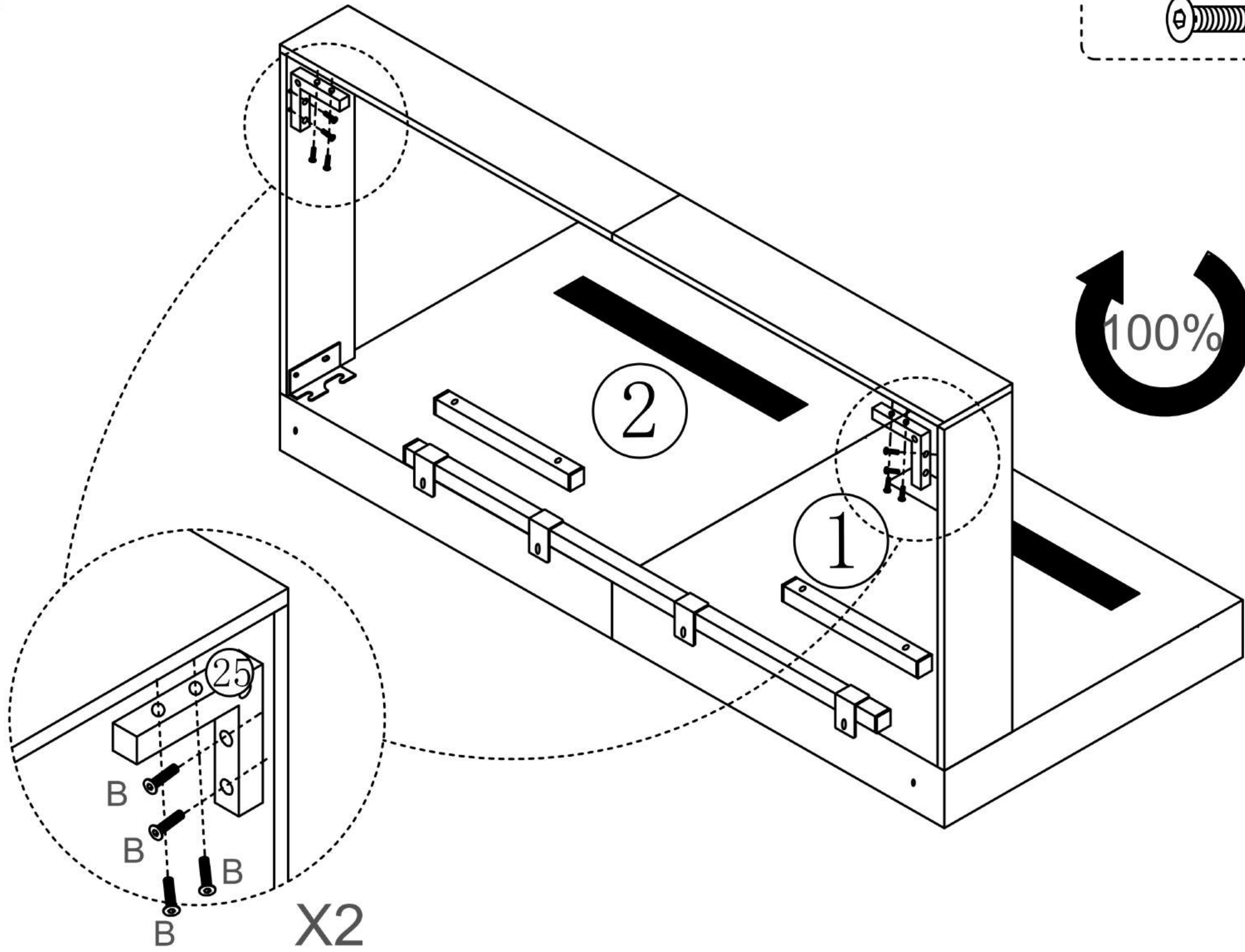

10

37

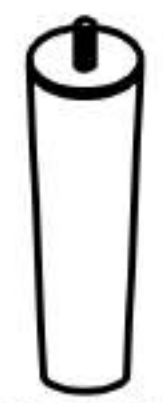

X5

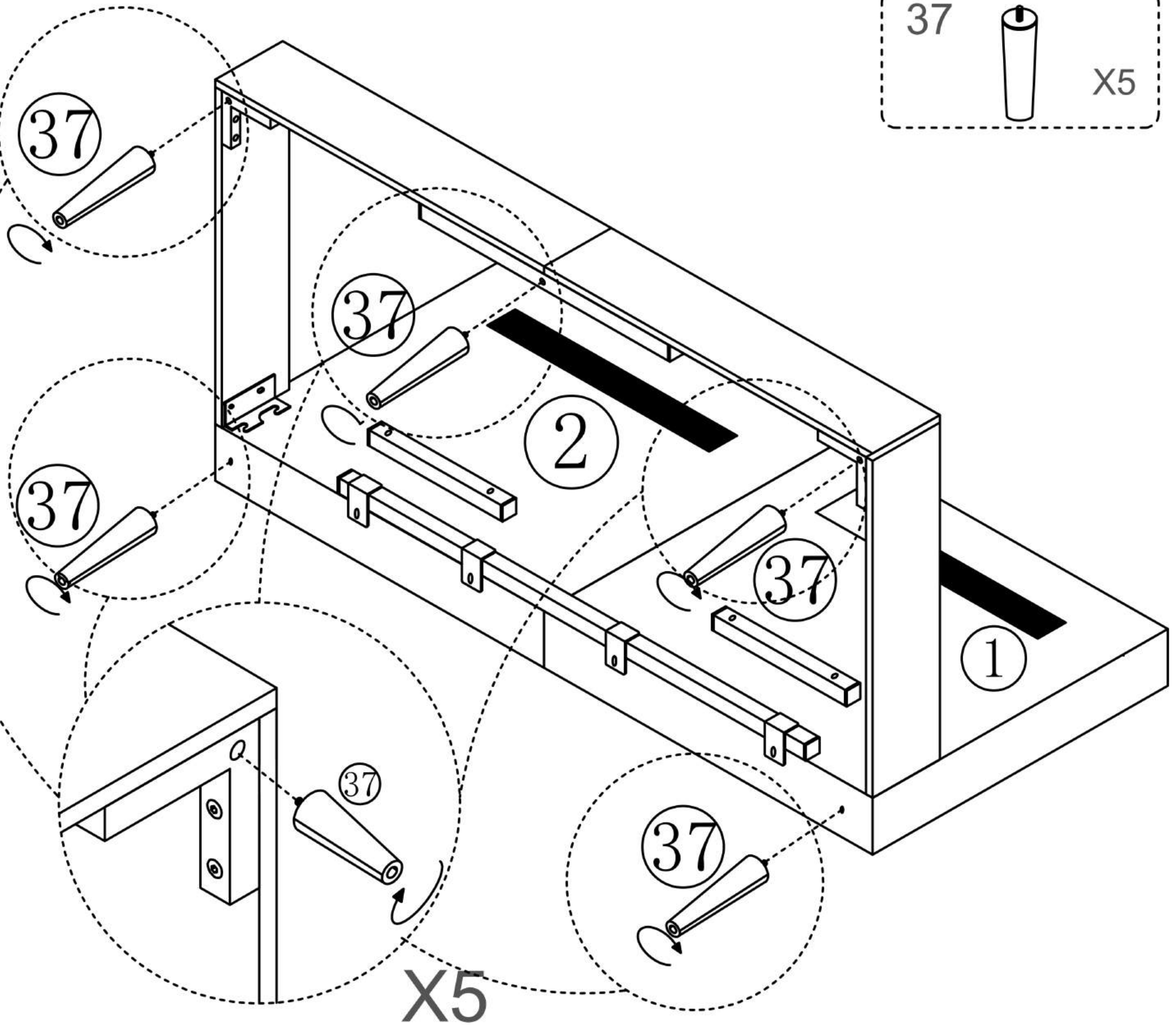

11

DE: Bitte montieren Sie die Seite mit dem Aufkleber oben.
EN: Please assemble the side with the sticker on top
FR: Veuillez assembler le côté avec l'autocollant sur le dessus.
IT: Si prega di assemblare il lato con la colla sopra.
ES: Por favor, ensamble el lado con la etiqueta en la parte superior.



(DE): Stille Aufkleber
(EN): Silent sticker
(FR): Stickers silencieux
(IT): Etichetta silenziosa
(ES): Estuche silencioso

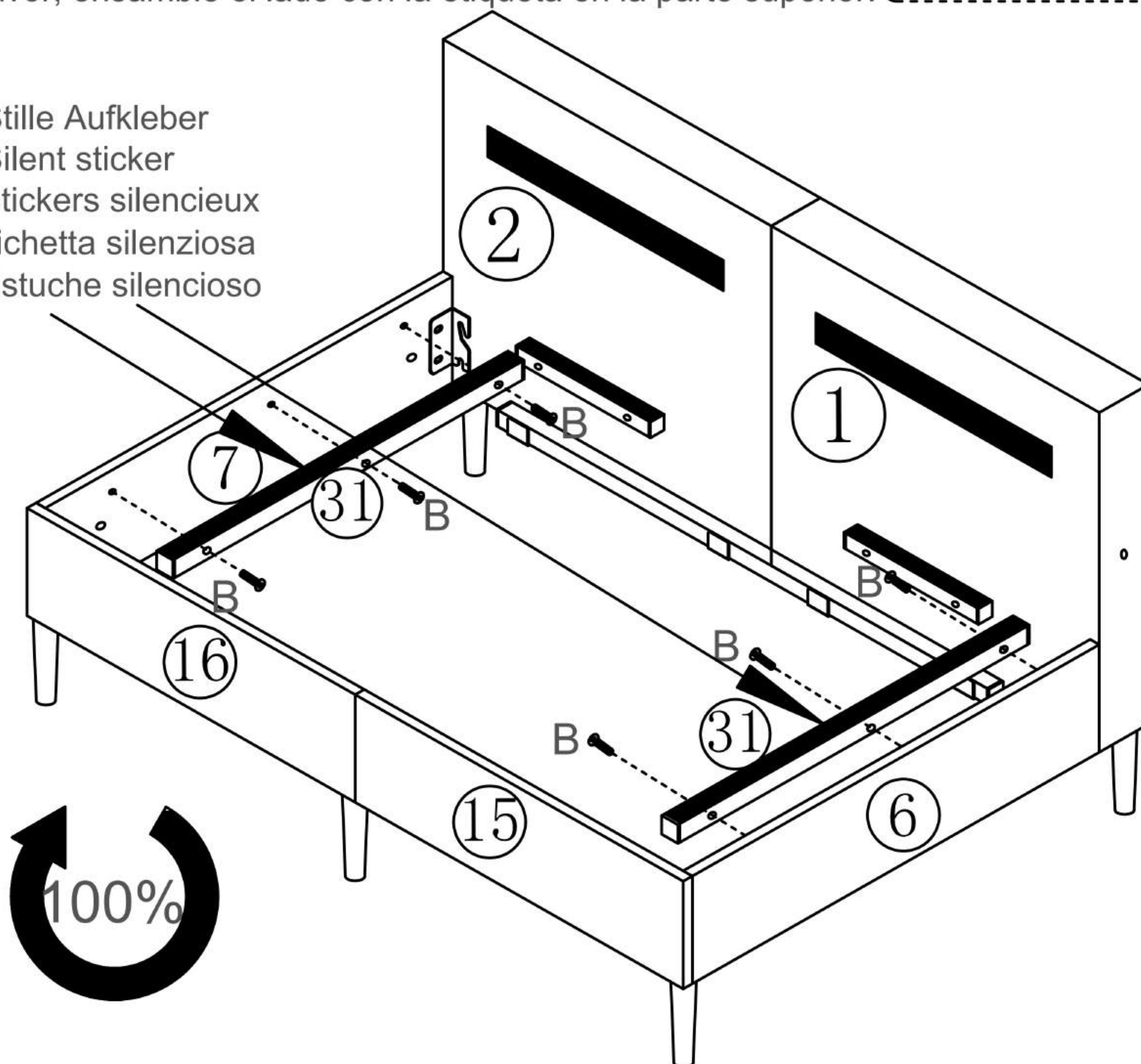

12

DE: Bitte montieren Sie die Seite mit dem Aufkleber oben.
EN: Please assemble the side with the sticker on top
FR: Veuillez assembler le côté avec l'autocollant sur le dessus.
IT: Si prega di assemblare il lato con la colla sopra.
ES: Por favor, ensamble el lado con la etiqueta en la parte superior.



(DE): Stille Aufkleber
(EN): Silent sticker
(FR): Stickers silencieux
(IT): Etichetta silenziosa
(ES): Estuche silencioso

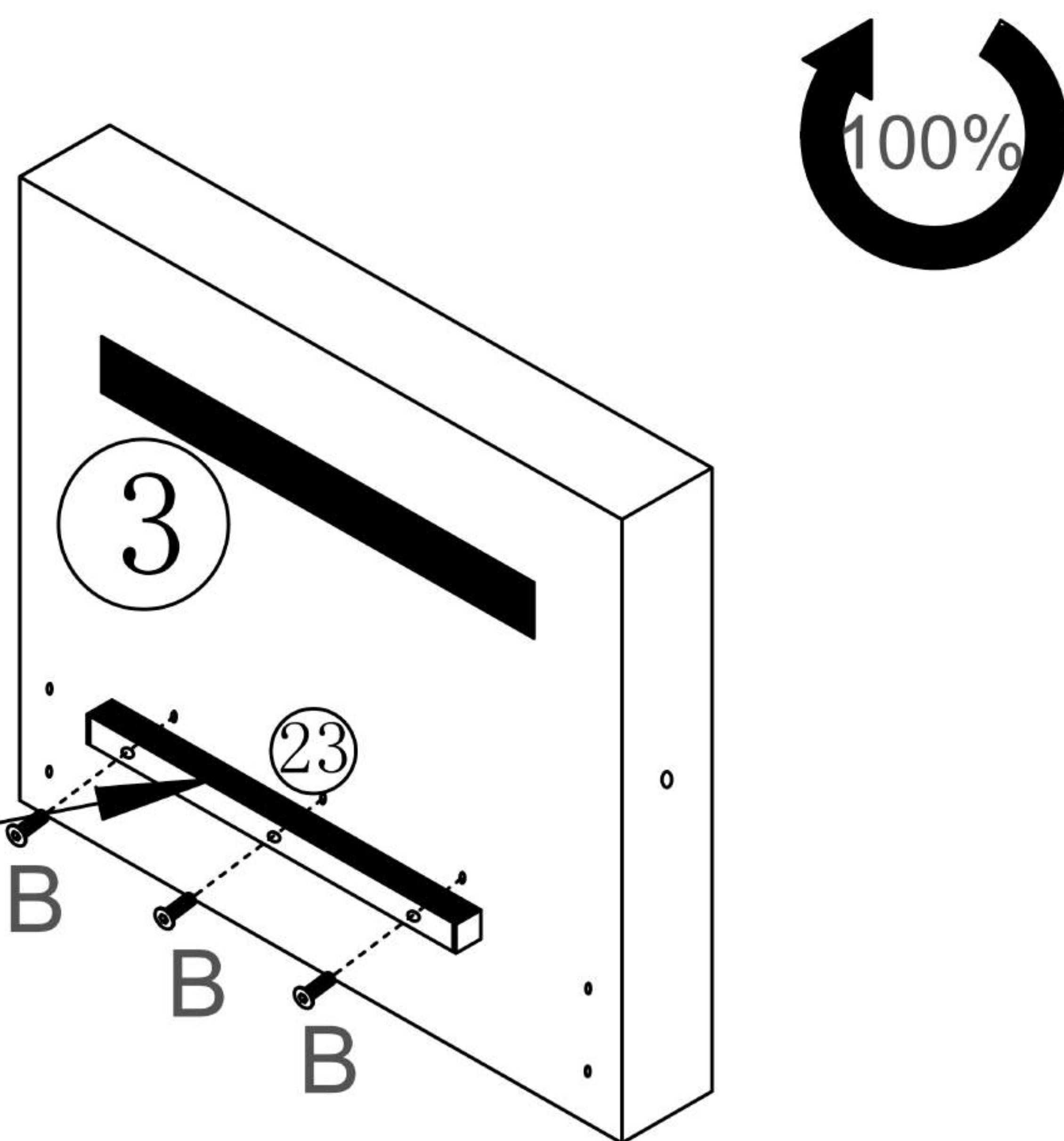

13

A M8*16
X4

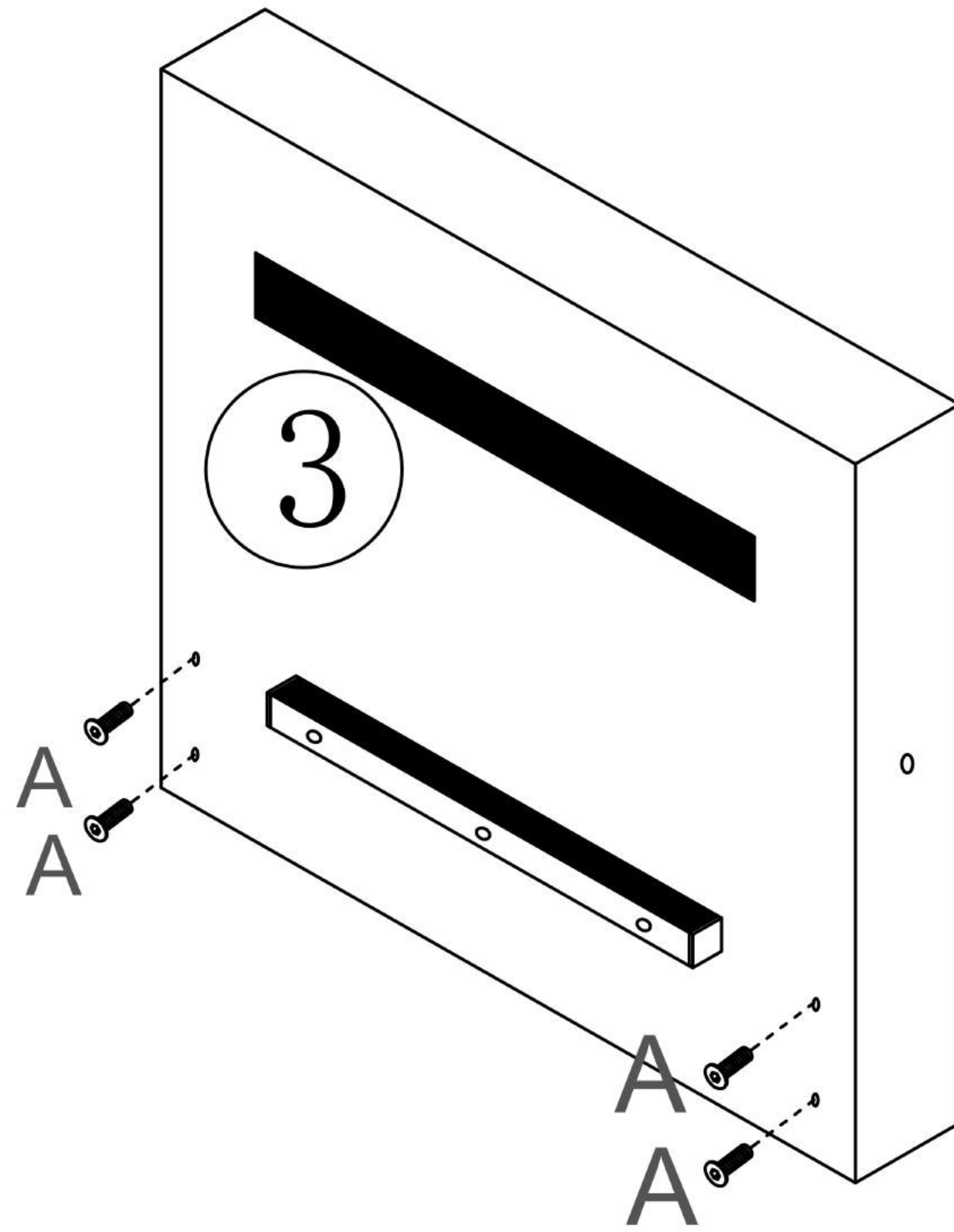

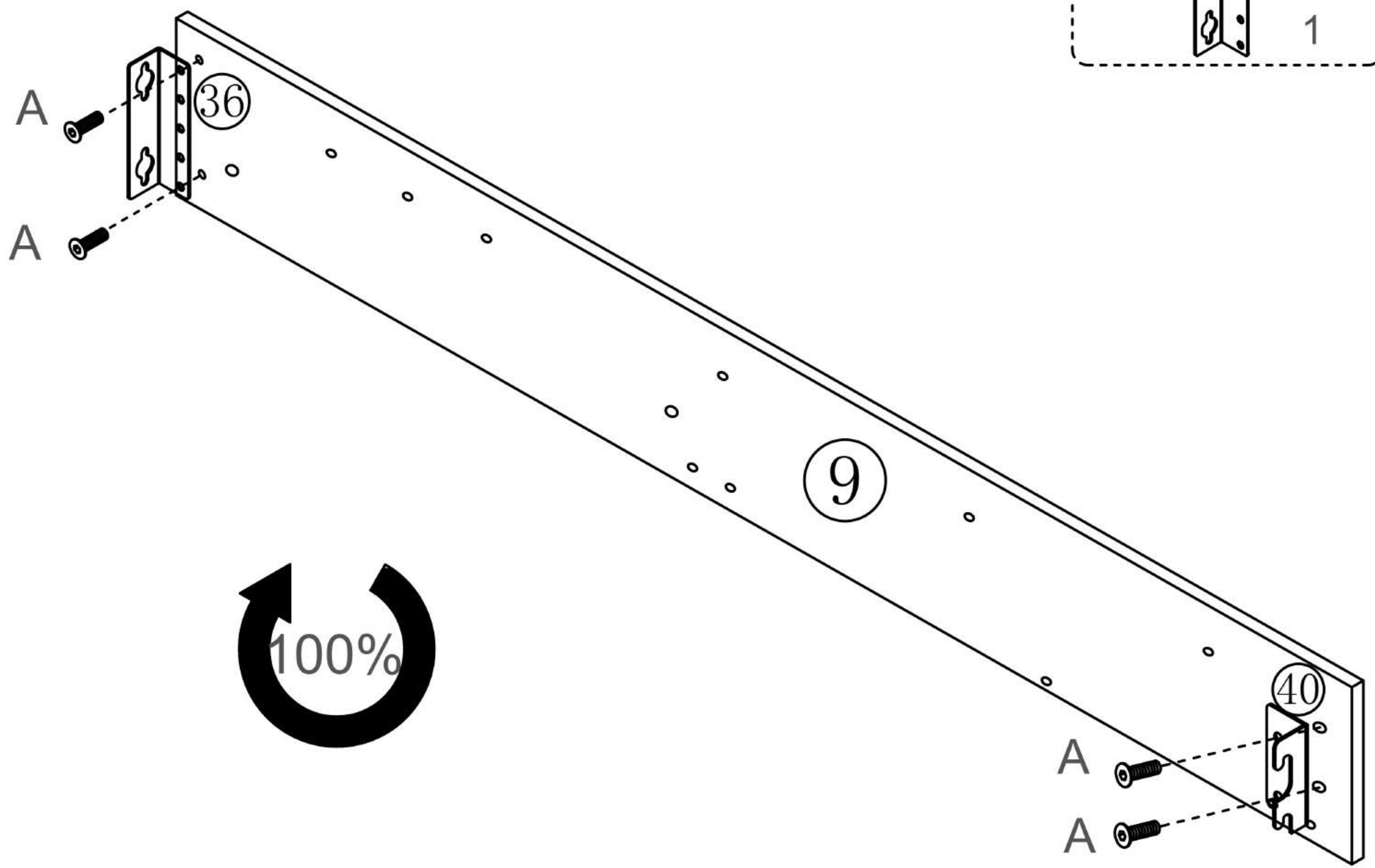

14

40 X1
A M8*16 X4
36 1

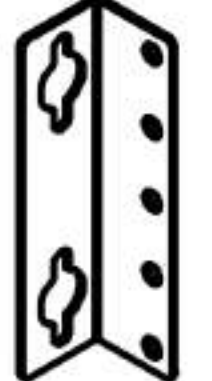

15

39		X1	A M8*16		X4
36		1			

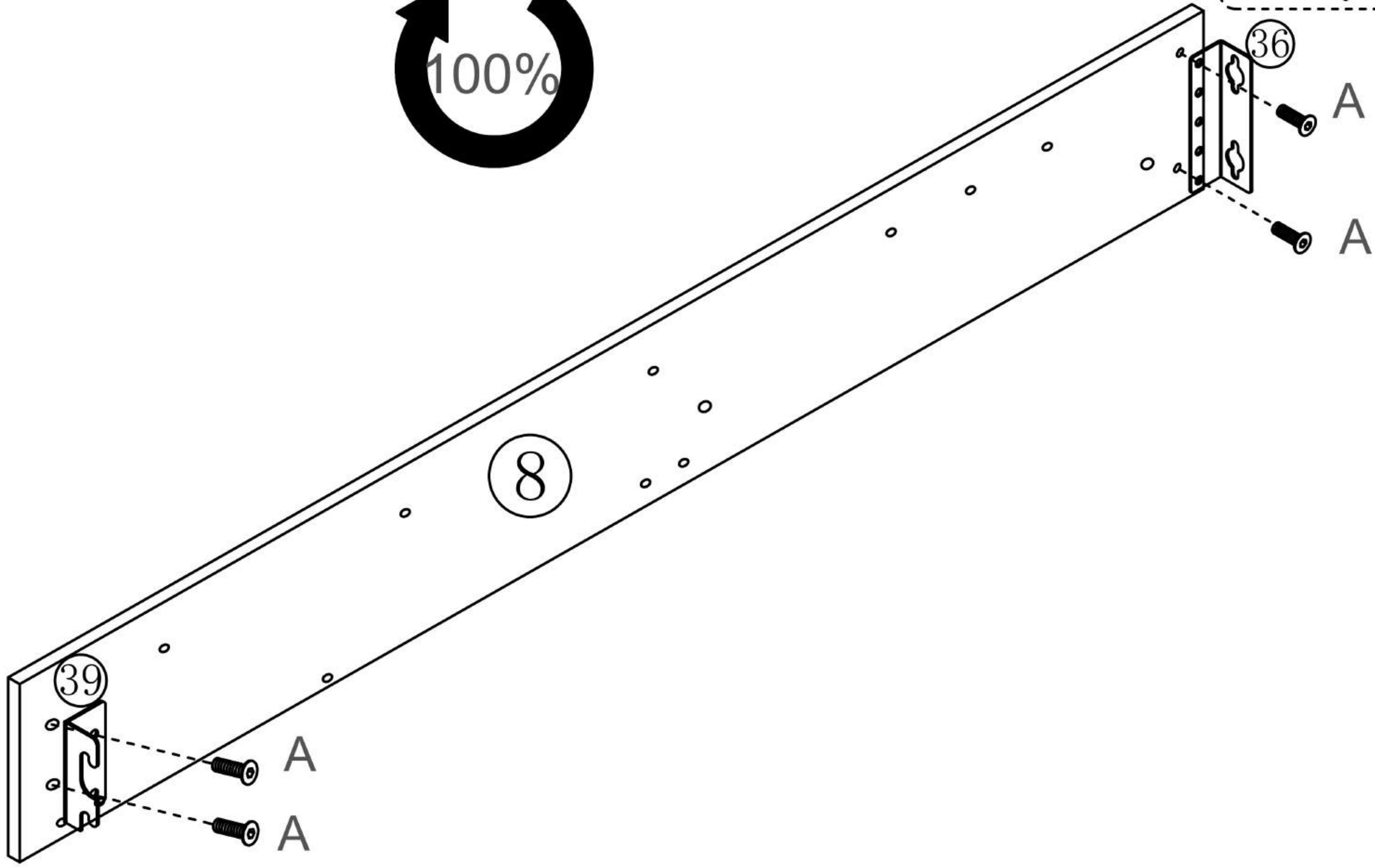
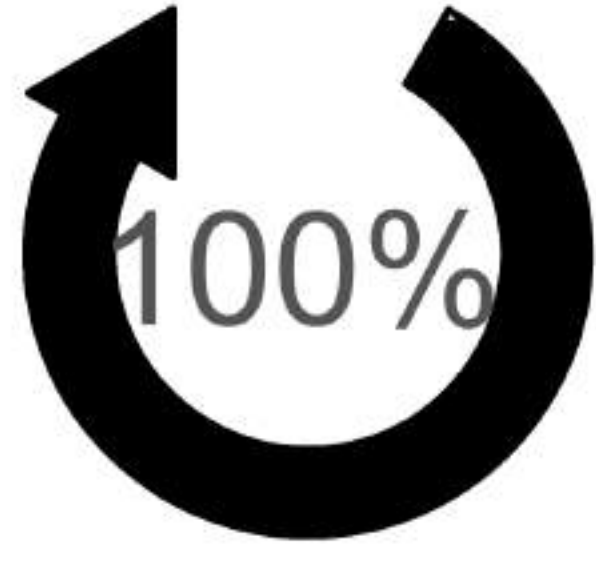

16

A M8*16		X4
---------	---	----

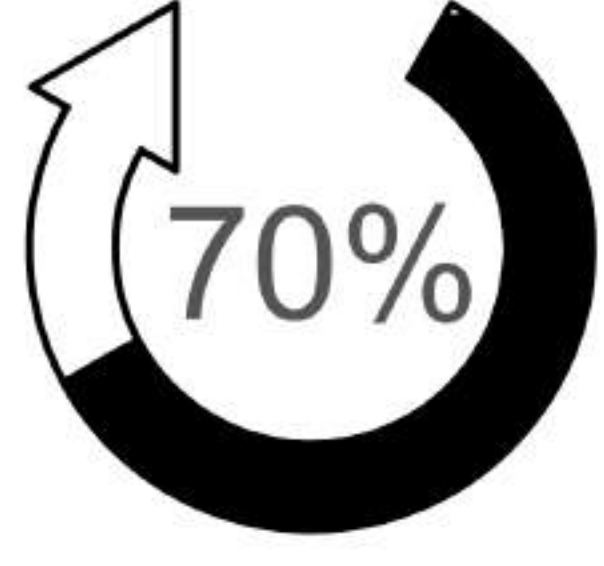
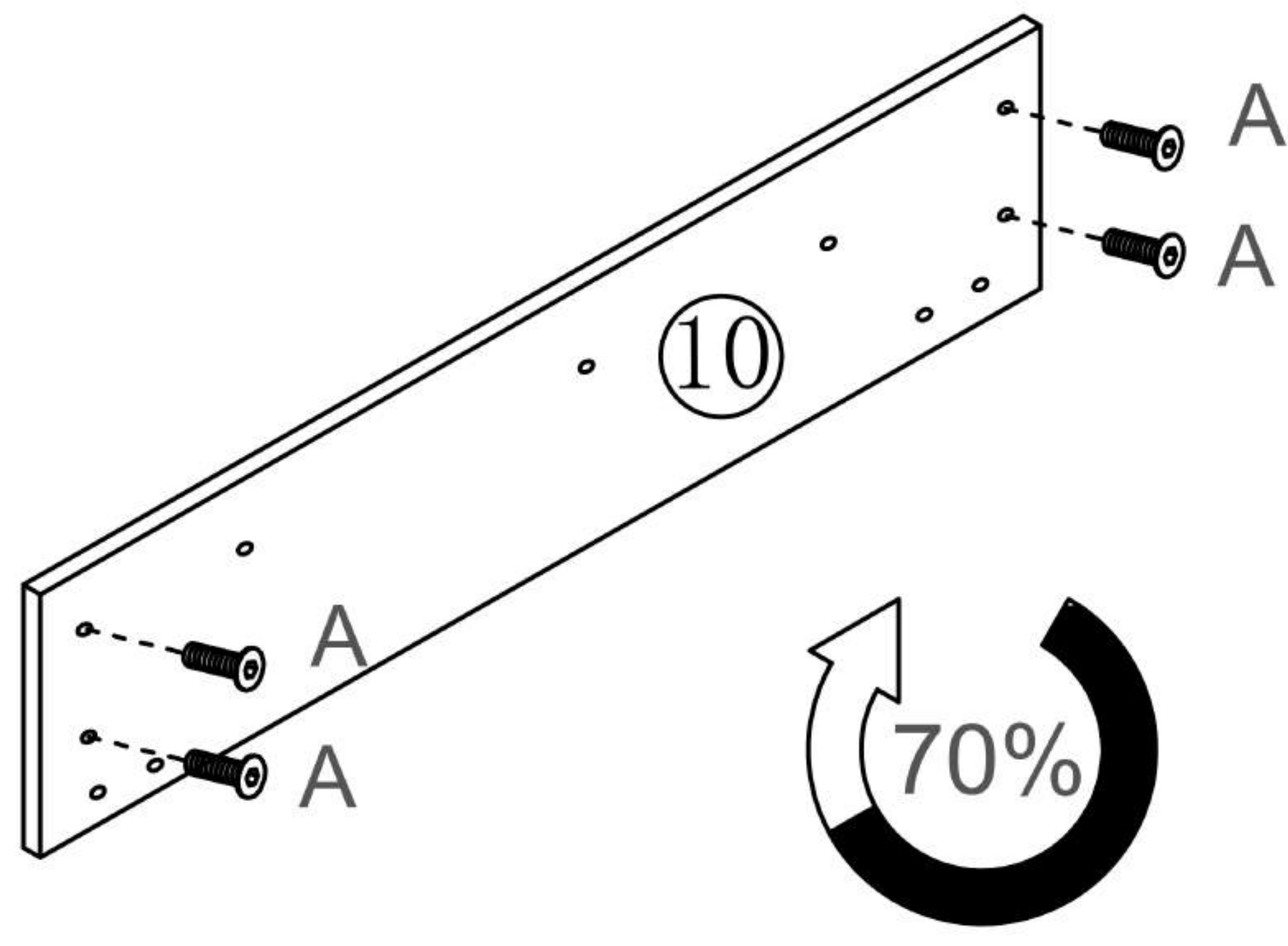

17

DE: Bitte montieren Sie die Seite mit dem Aufkleber oben.
EN: Please assemble the side with the sticker on top.
FR: Veuillez assembler le côté avec l'autocollant sur le dessus.
IT: Si prega di assemblare il lato con la colla sopra.
ES: Por favor, ensamble el lado con la etiqueta en la parte superior.

B M8*37
 X3

(DE): Stille Aufkleber
(EN): Silent sticker
(FR): Stickers silencieux
(IT): Etichetta silenziosa
(ES): Estuche silencioso

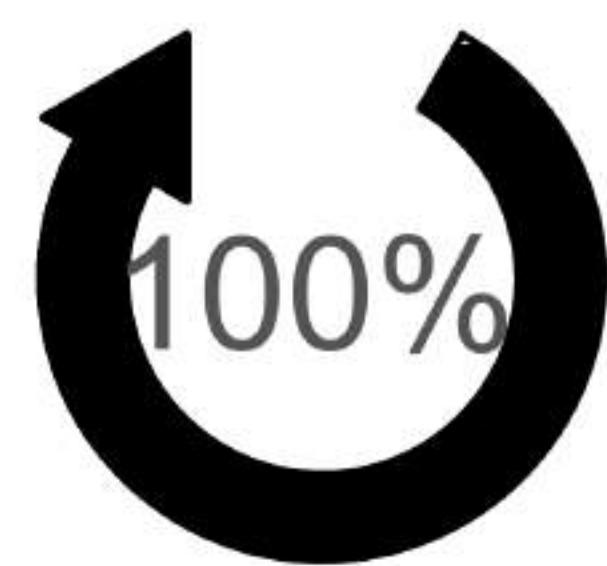
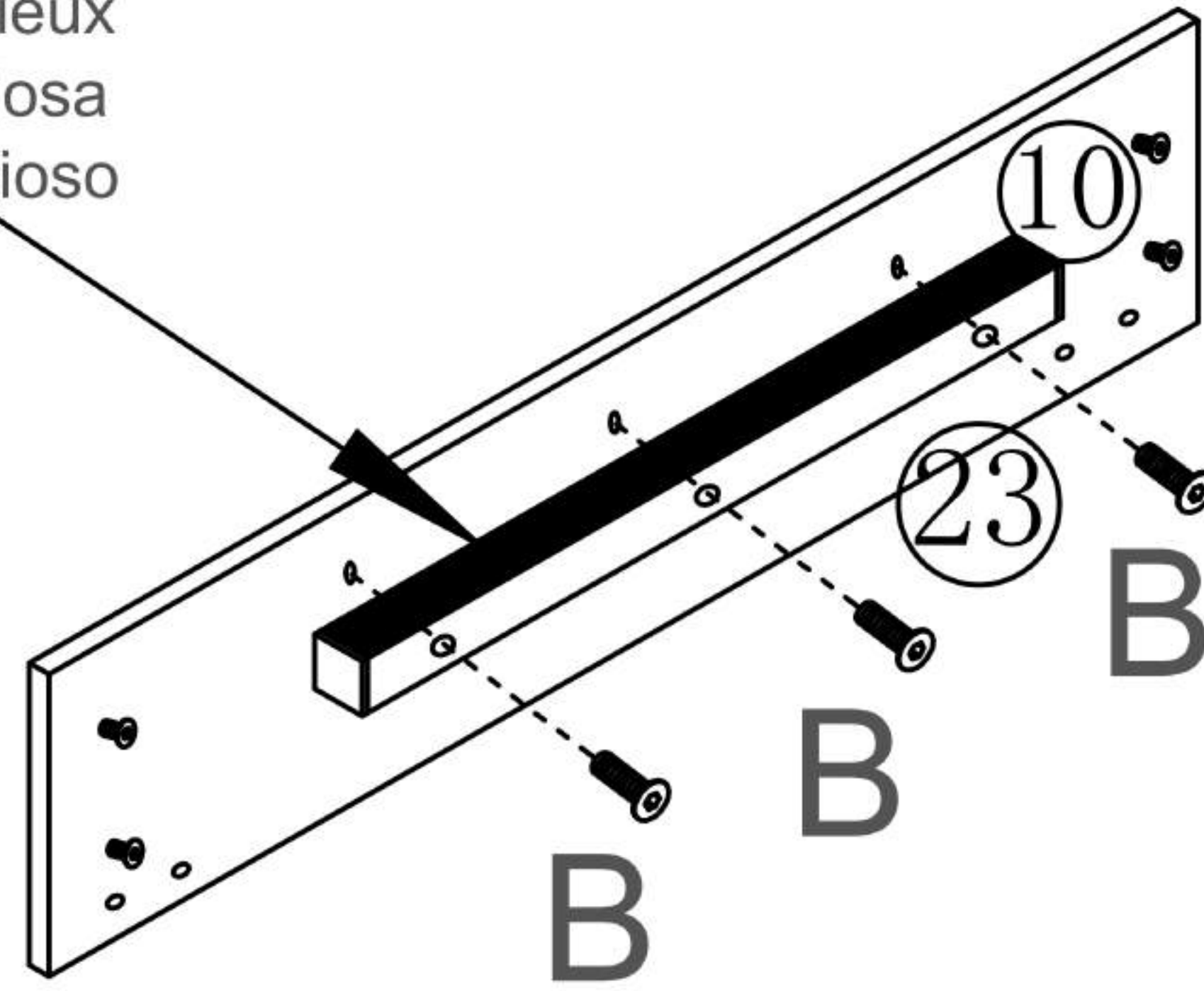

18

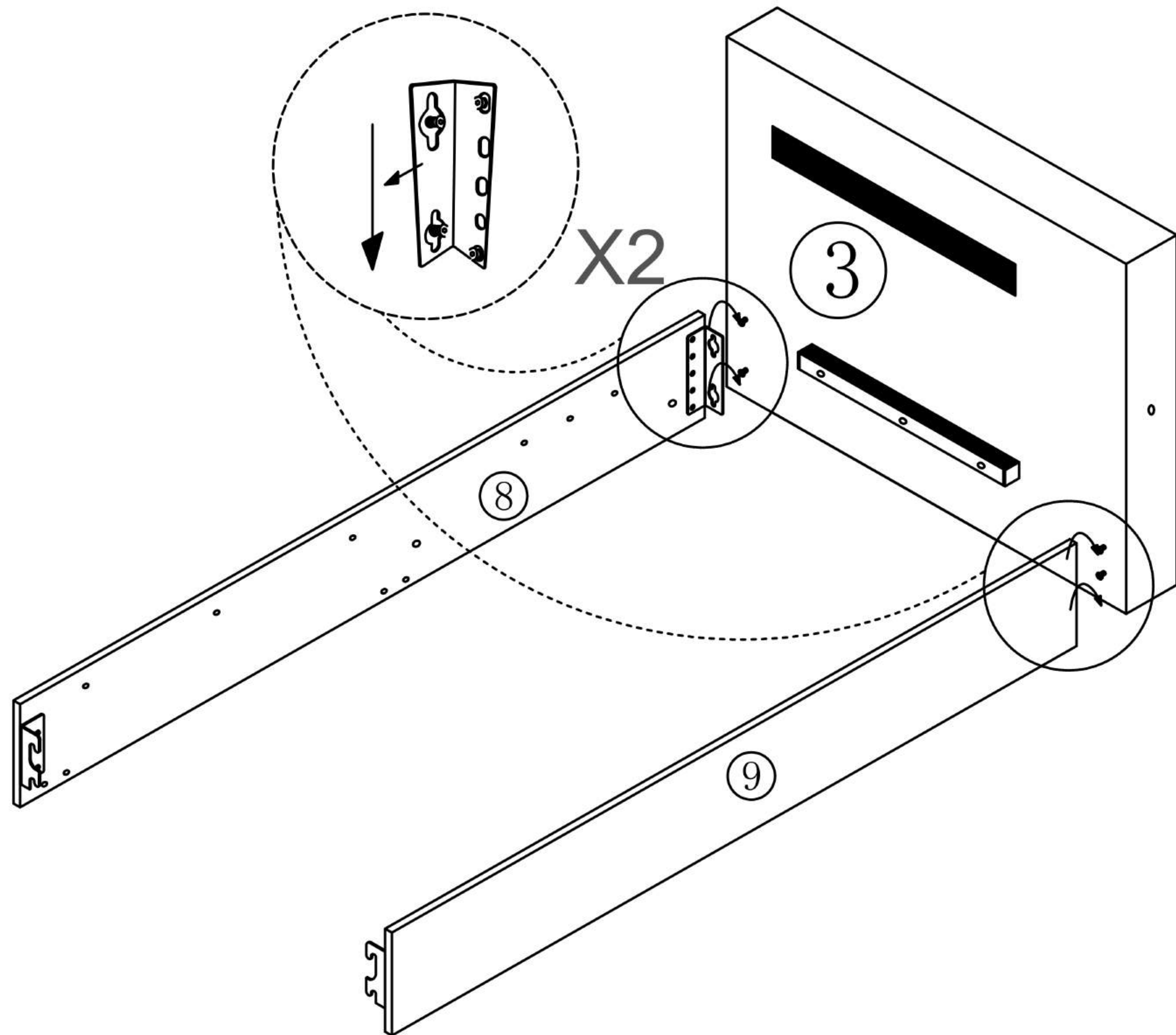

19

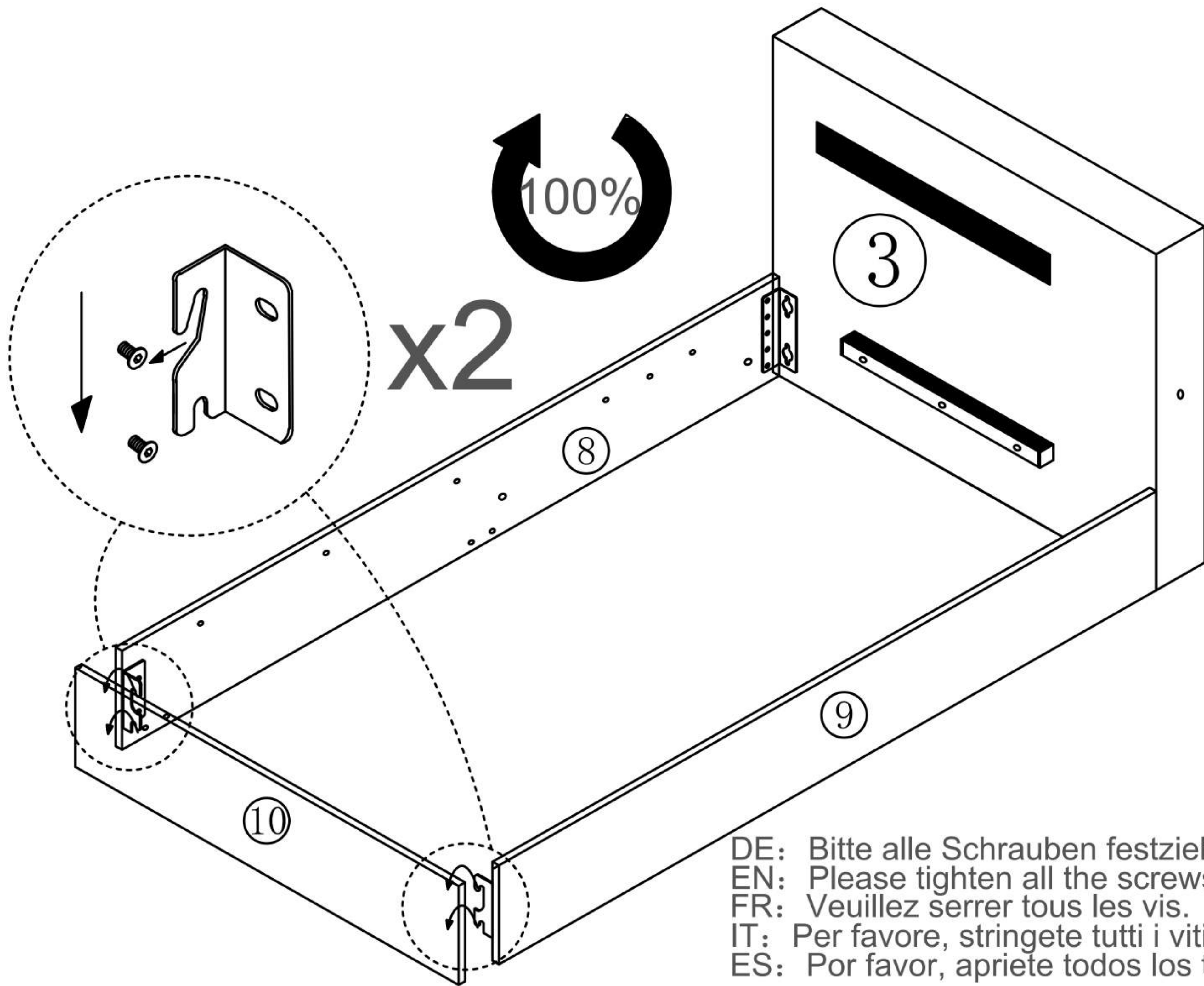

20

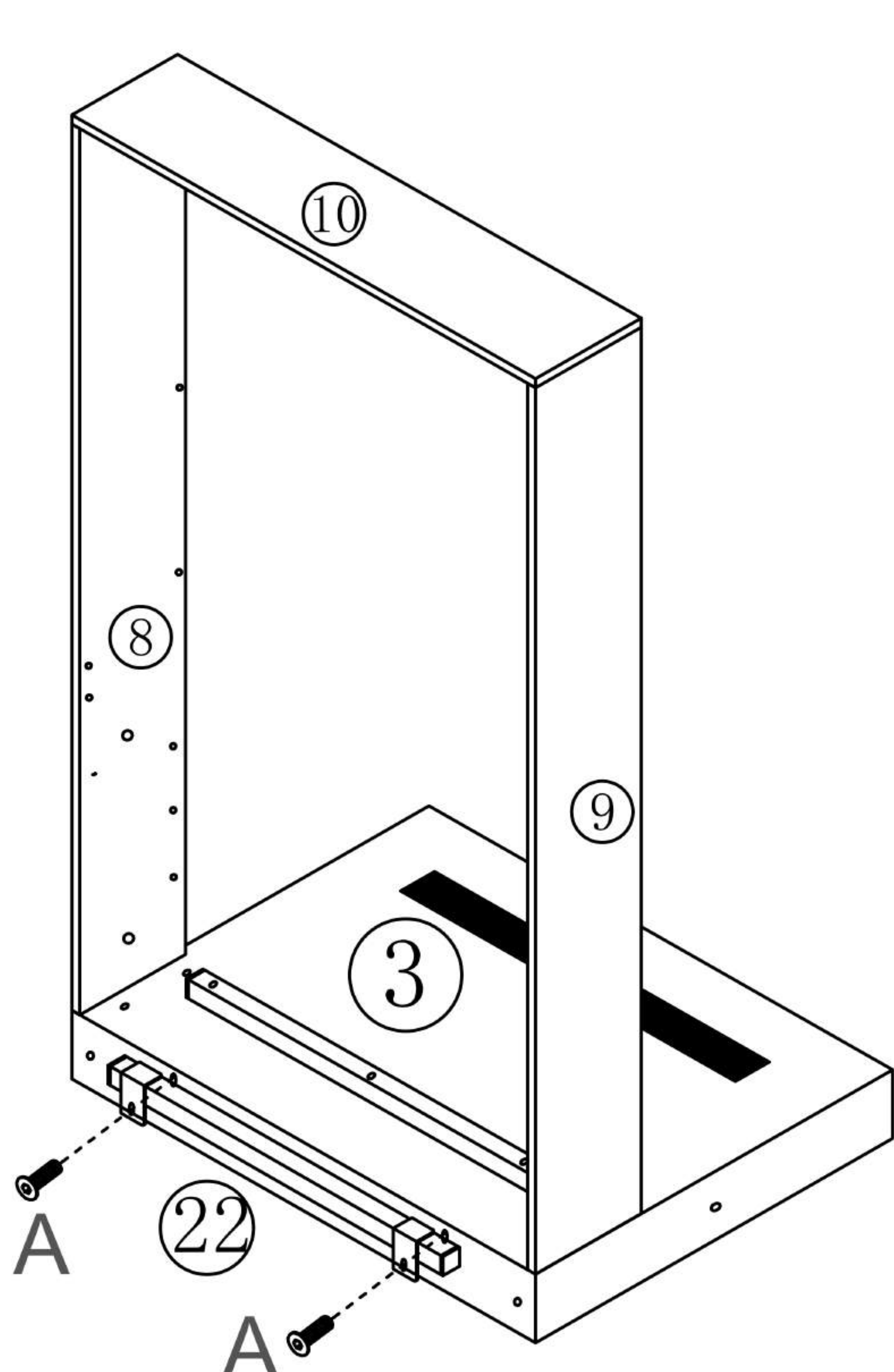

A M8*16
X2

21

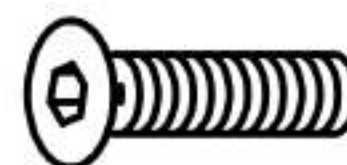
B M8*37
 X8

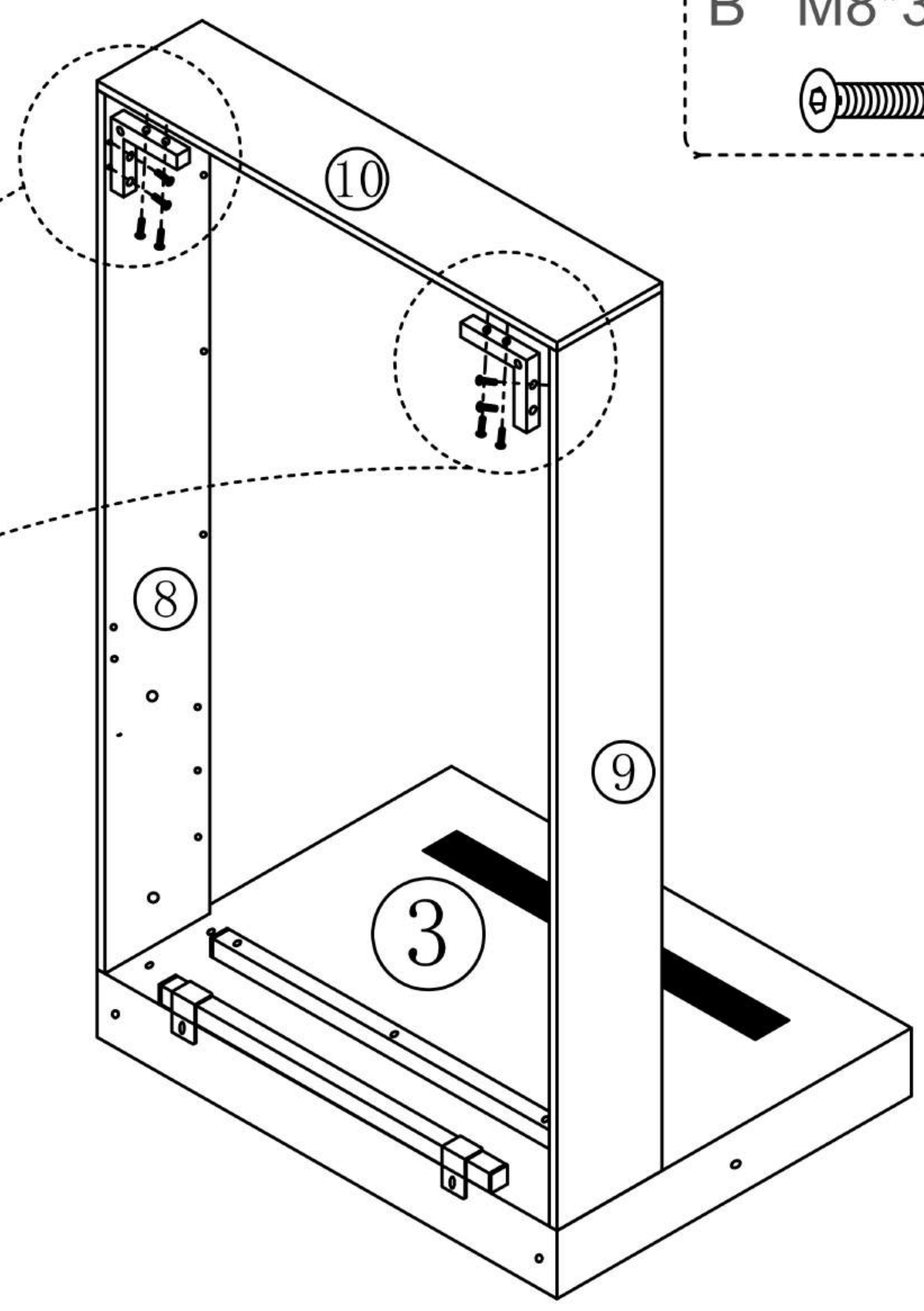
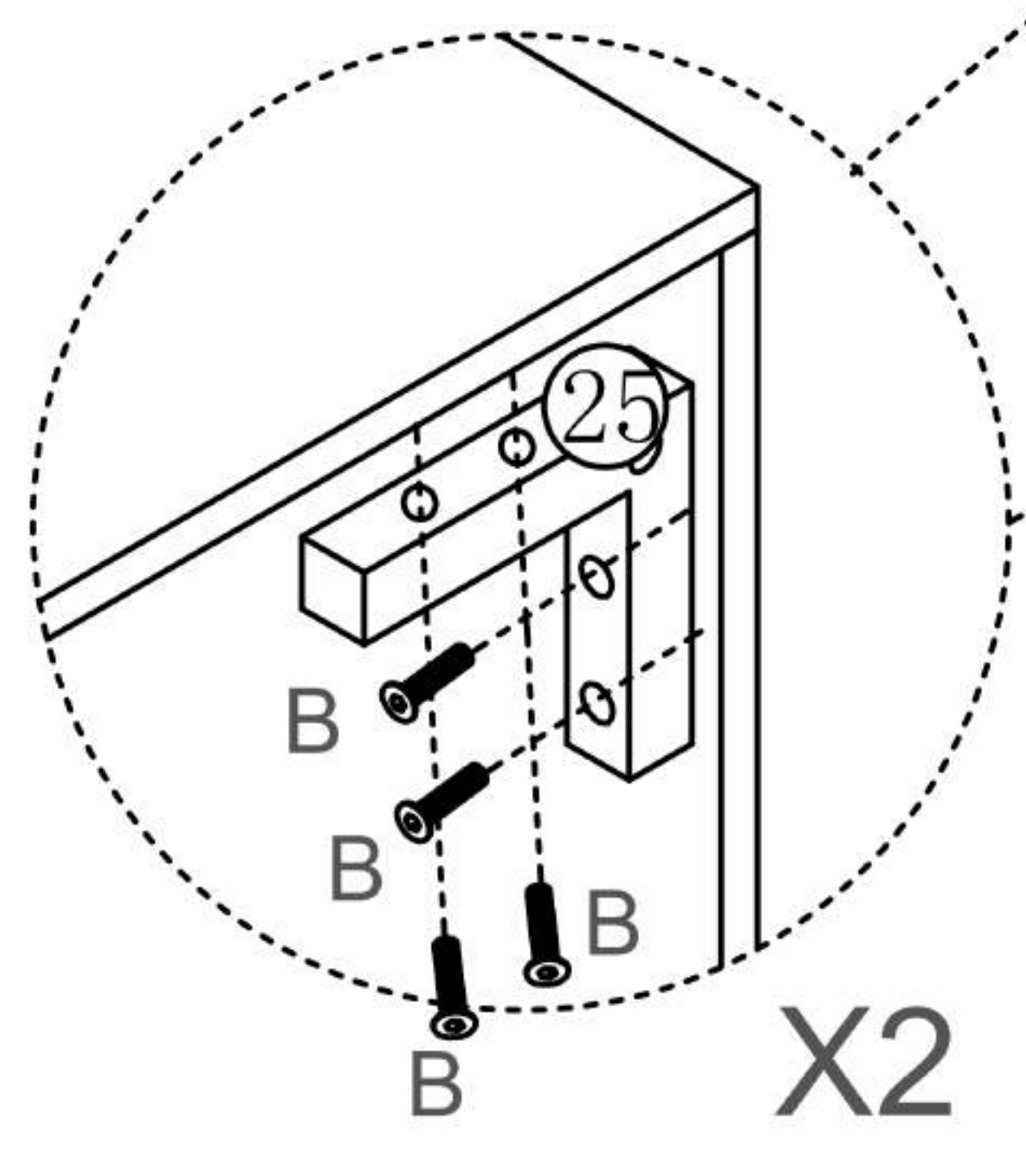

22

37
 X4

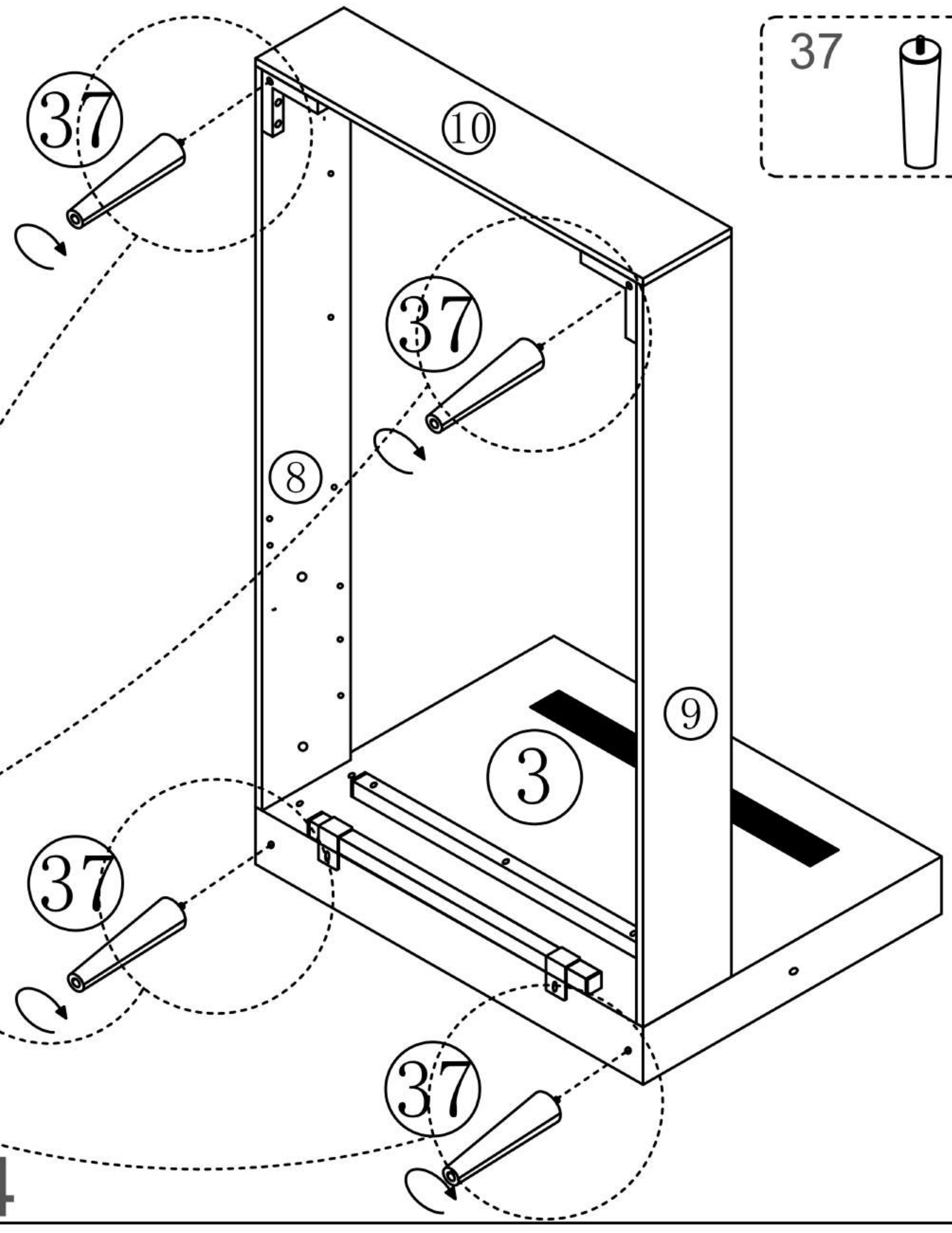
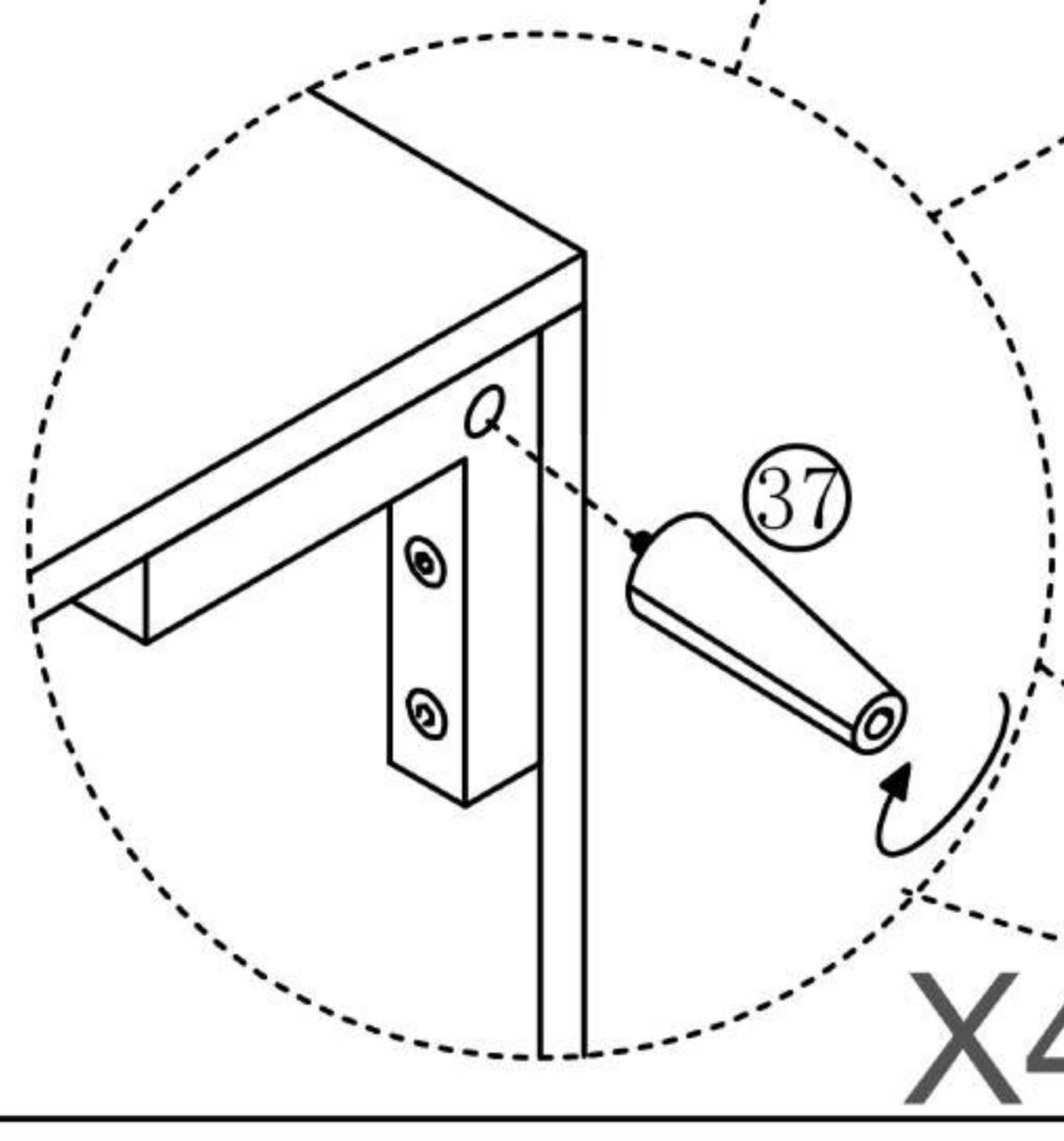

23

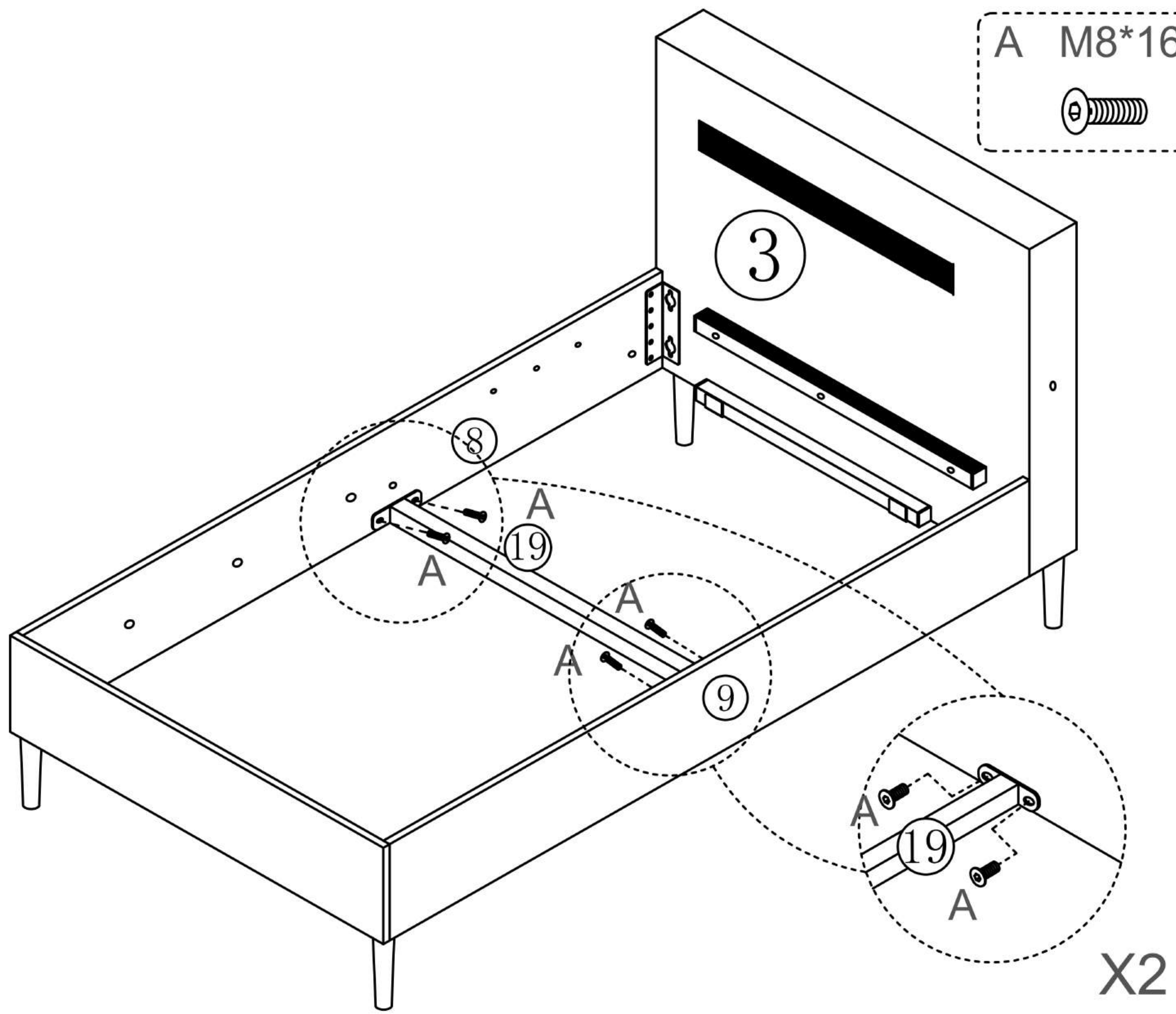

24-L

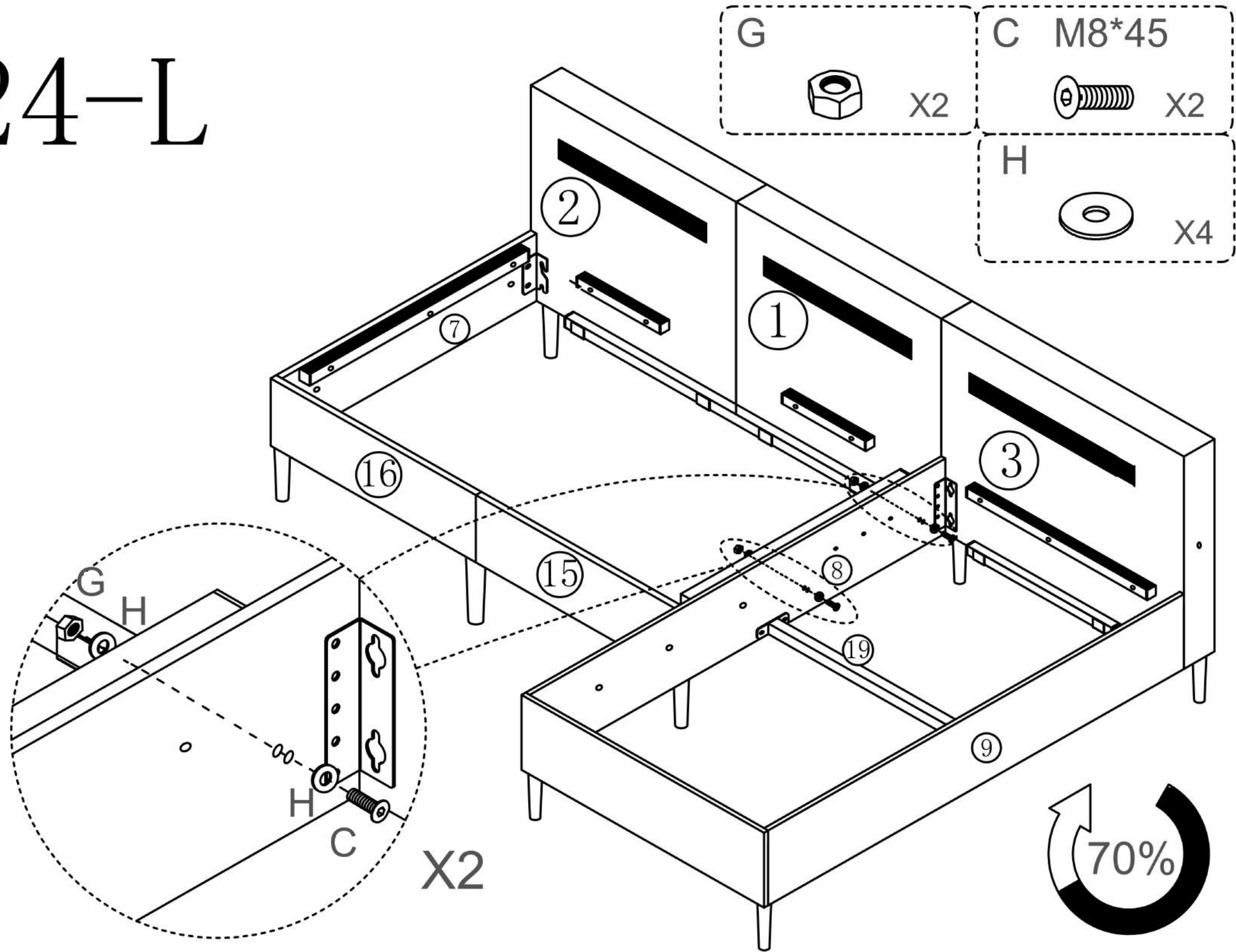

24-R

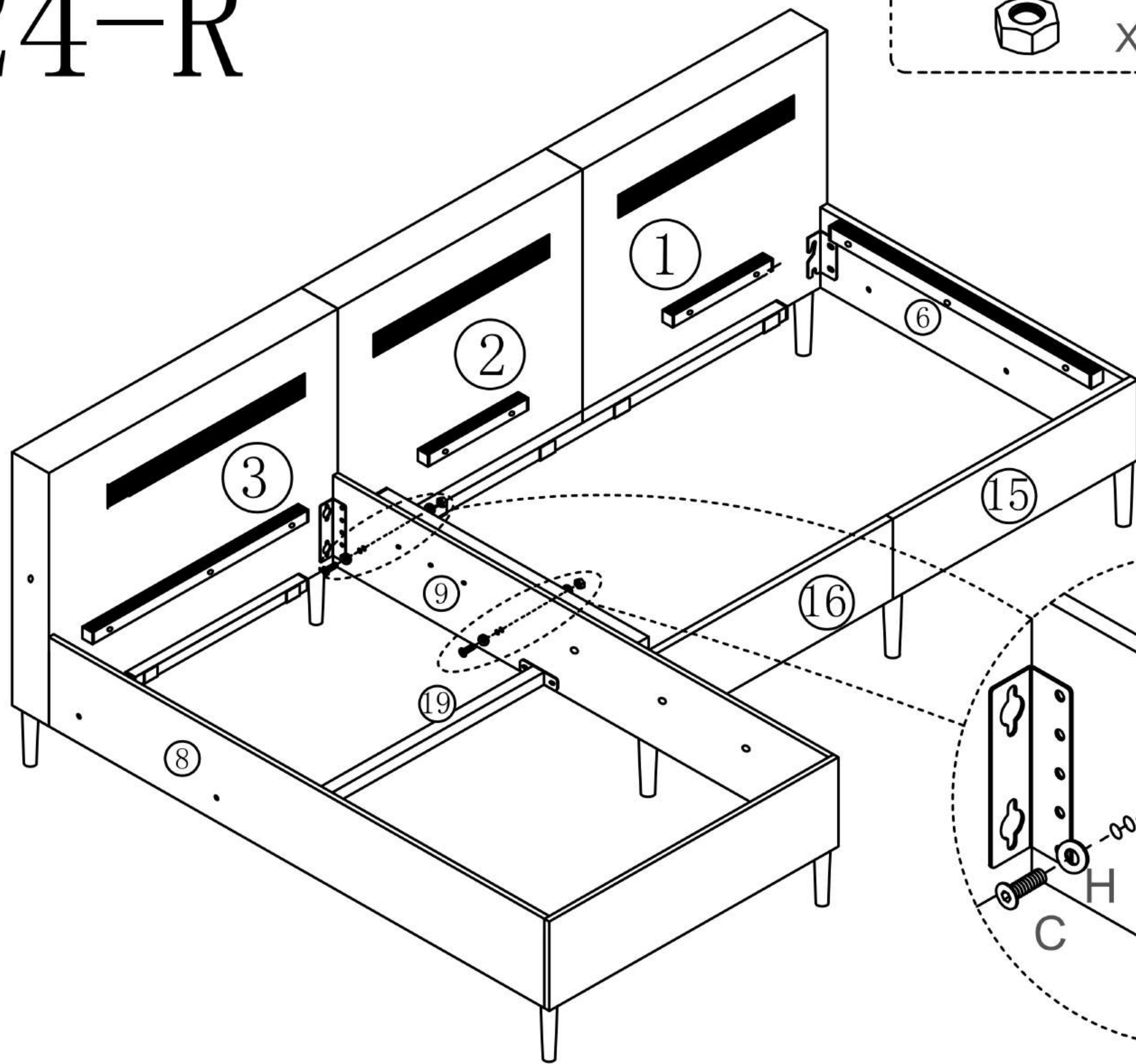

- | | | | |
|---|----|---------|----|
| G | X2 | C M8*45 | X2 |
| | | | |
| | | H | X4 |
| | | | |

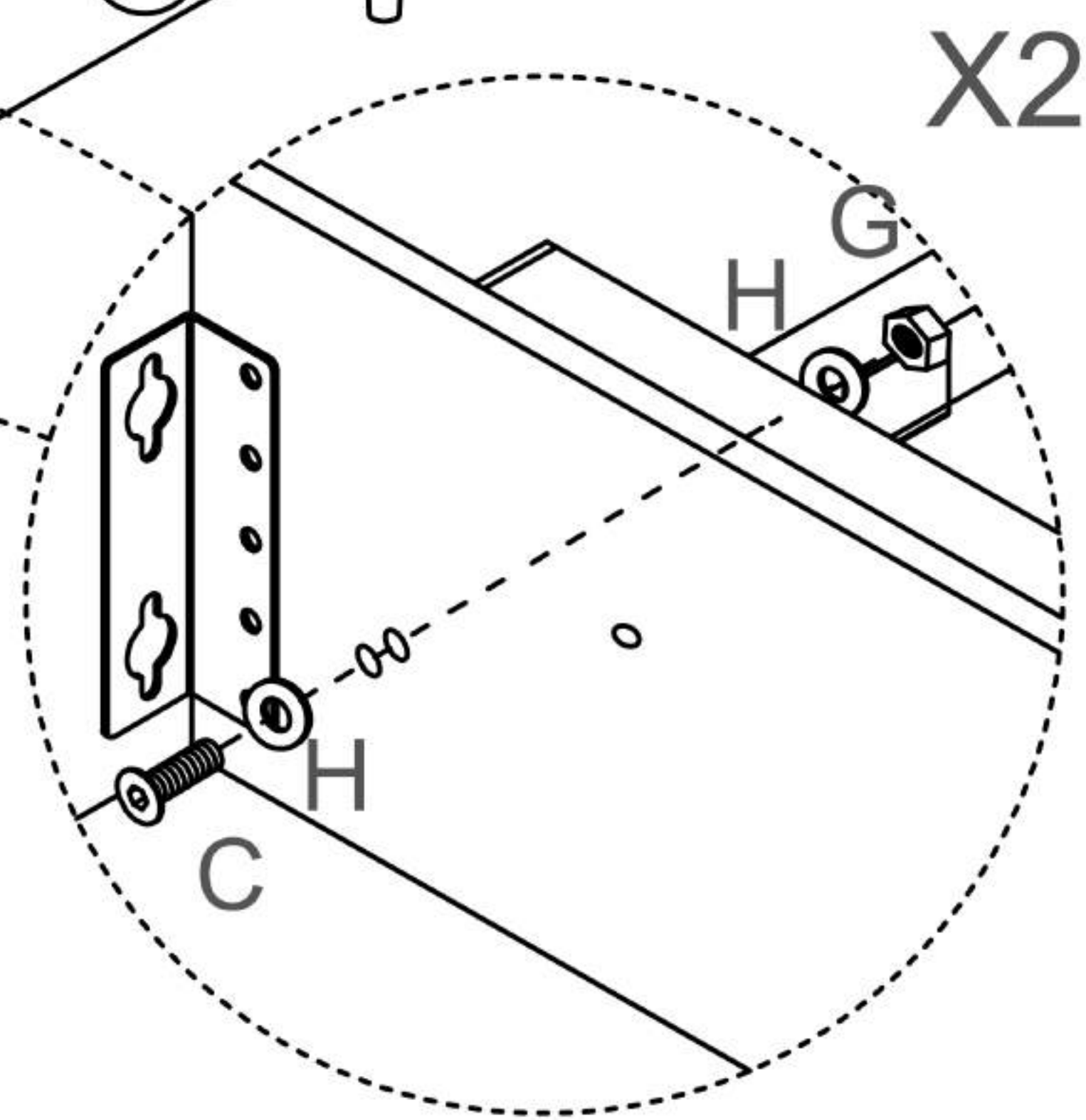

25-L

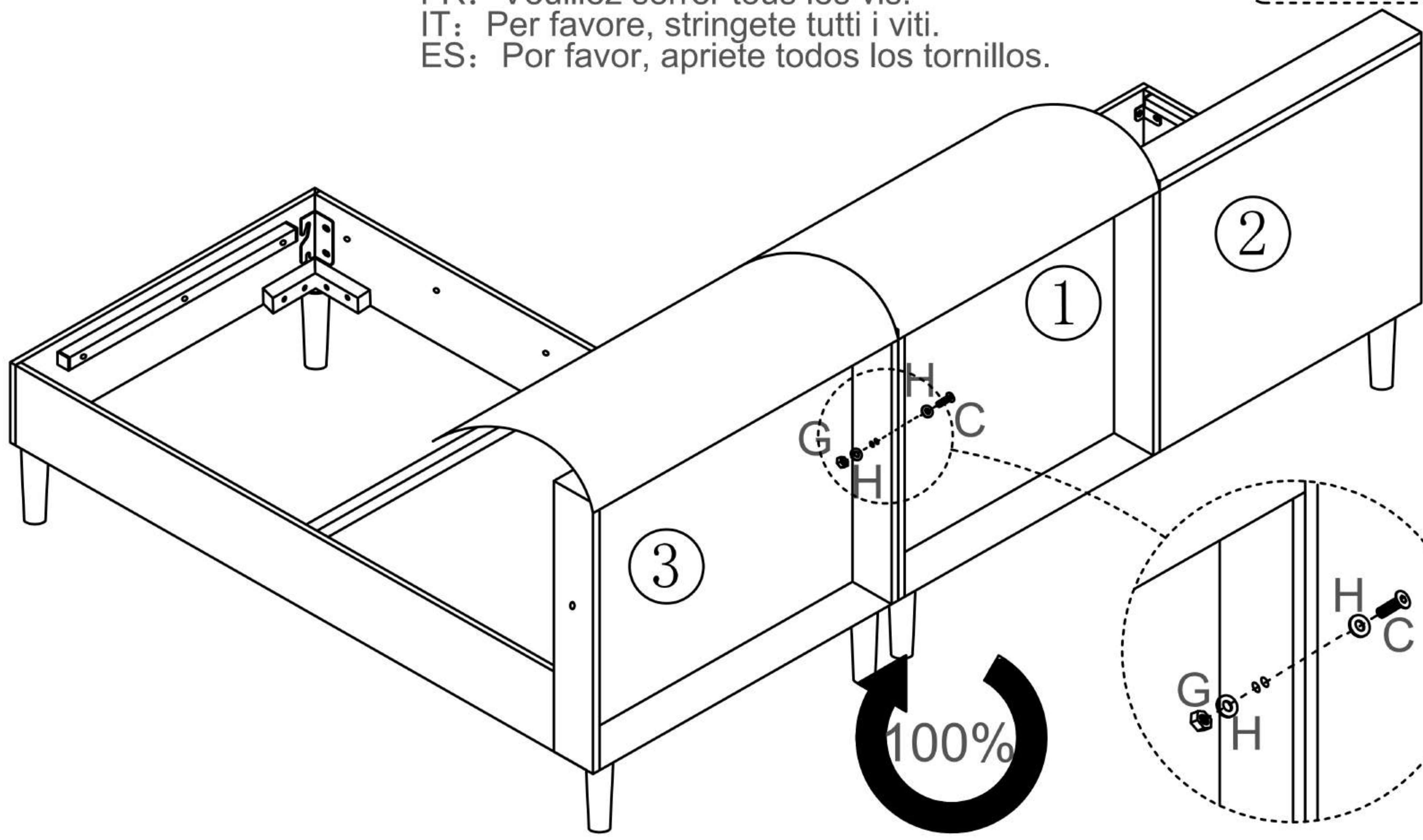

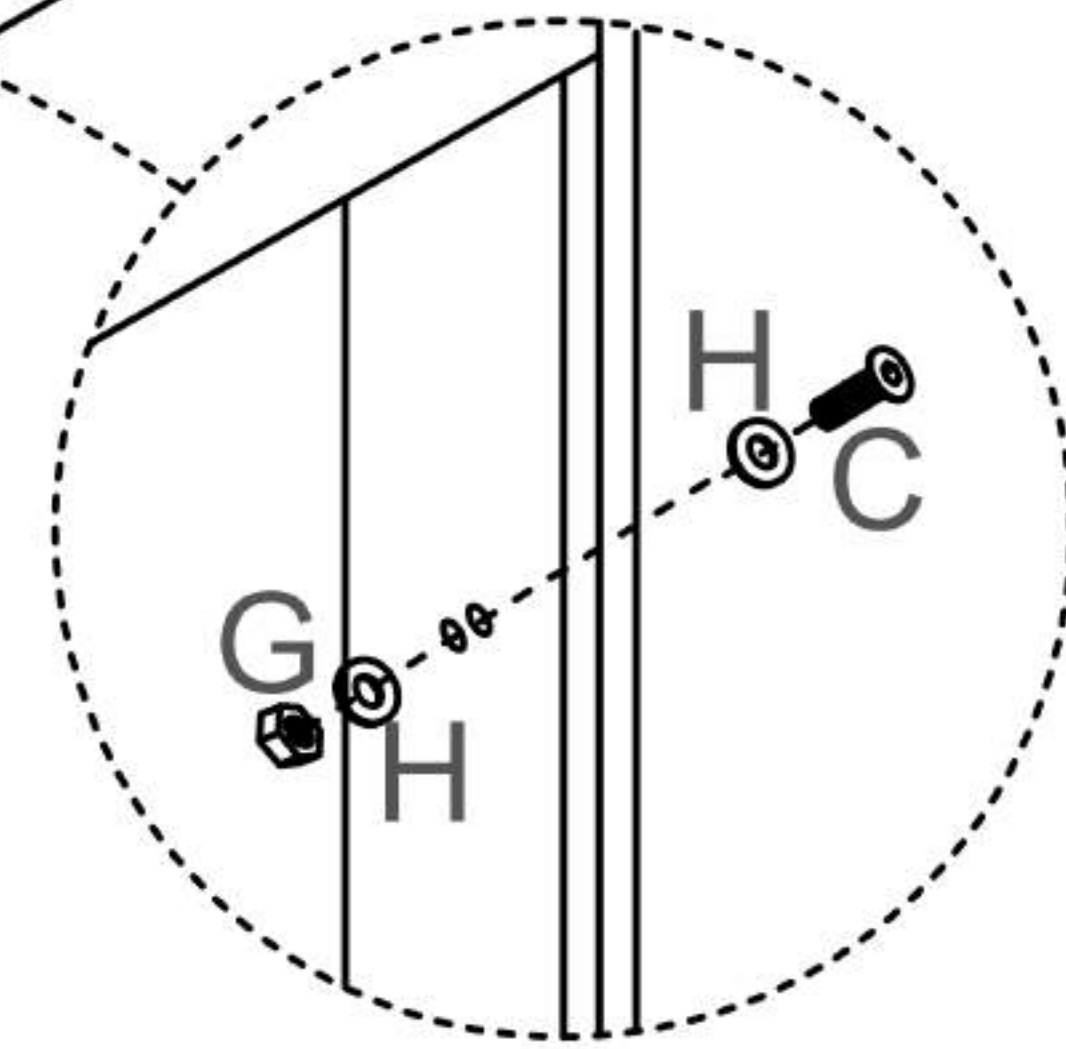

- | | | | |
|---|----|---------|----|
| G | X1 | C M8*45 | X1 |
| | | | |
| | | H | X2 |
| | | | |

DE: Bitte alle Schrauben festziehen.
EN: Please tighten all the screws.
FR: Veuillez serrer tous les vis.
IT: Per favore, stringete tutti i viti.
ES: Por favor, apriete todos los tornillos.



25-R

DE: Bitte alle Schrauben festziehen.
EN: Please tighten all the screws.
FR: Veuillez serrer tous les vis.
IT: Per favore, stringete tutti i viti.
ES: Por favor, apriete todos los tornillos.

G	C M8*45
 X1	 X1
H	
 X2	

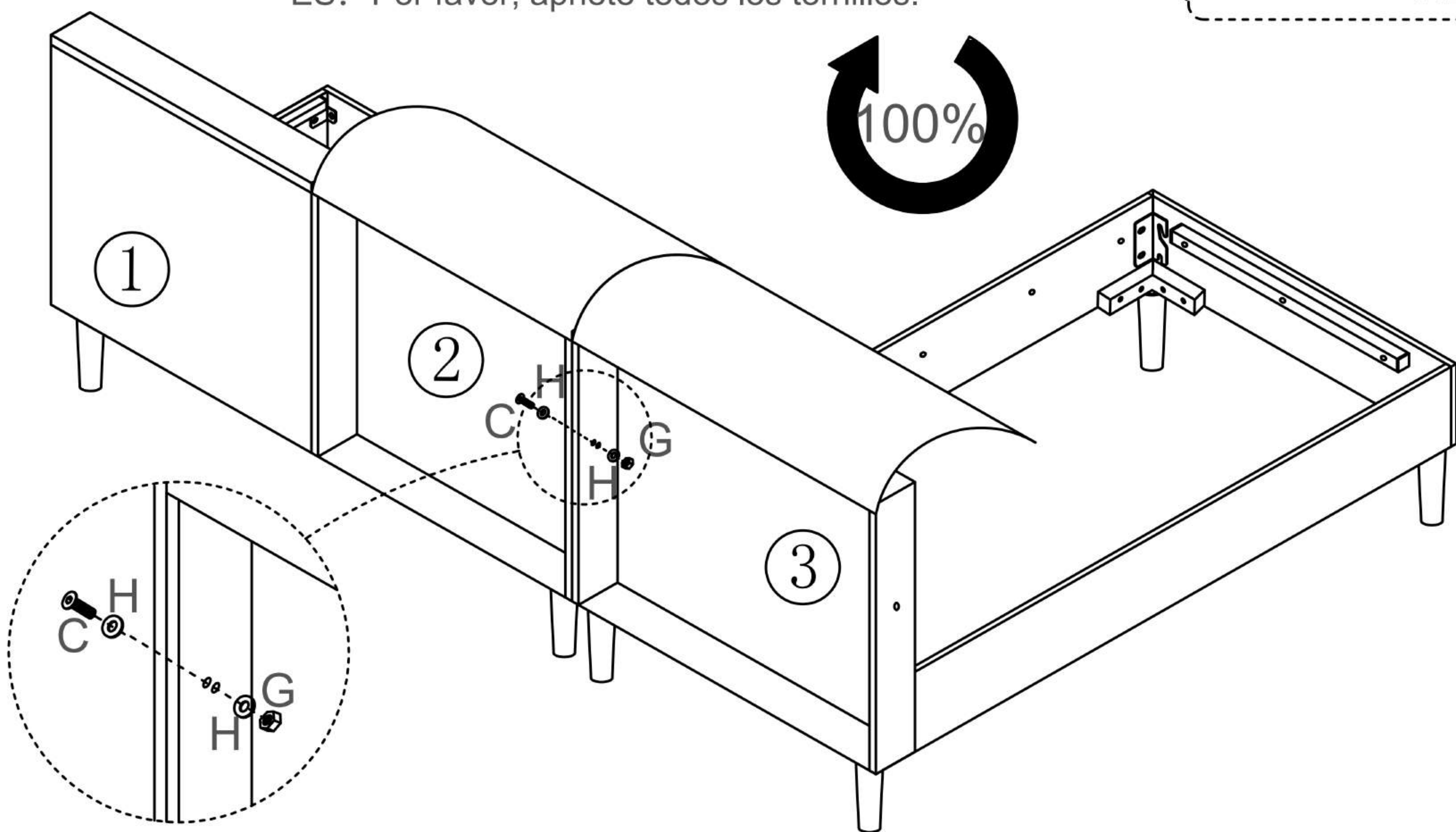

26-L

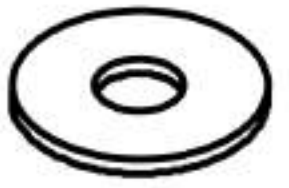
C M8*45
 X4
H
 X4

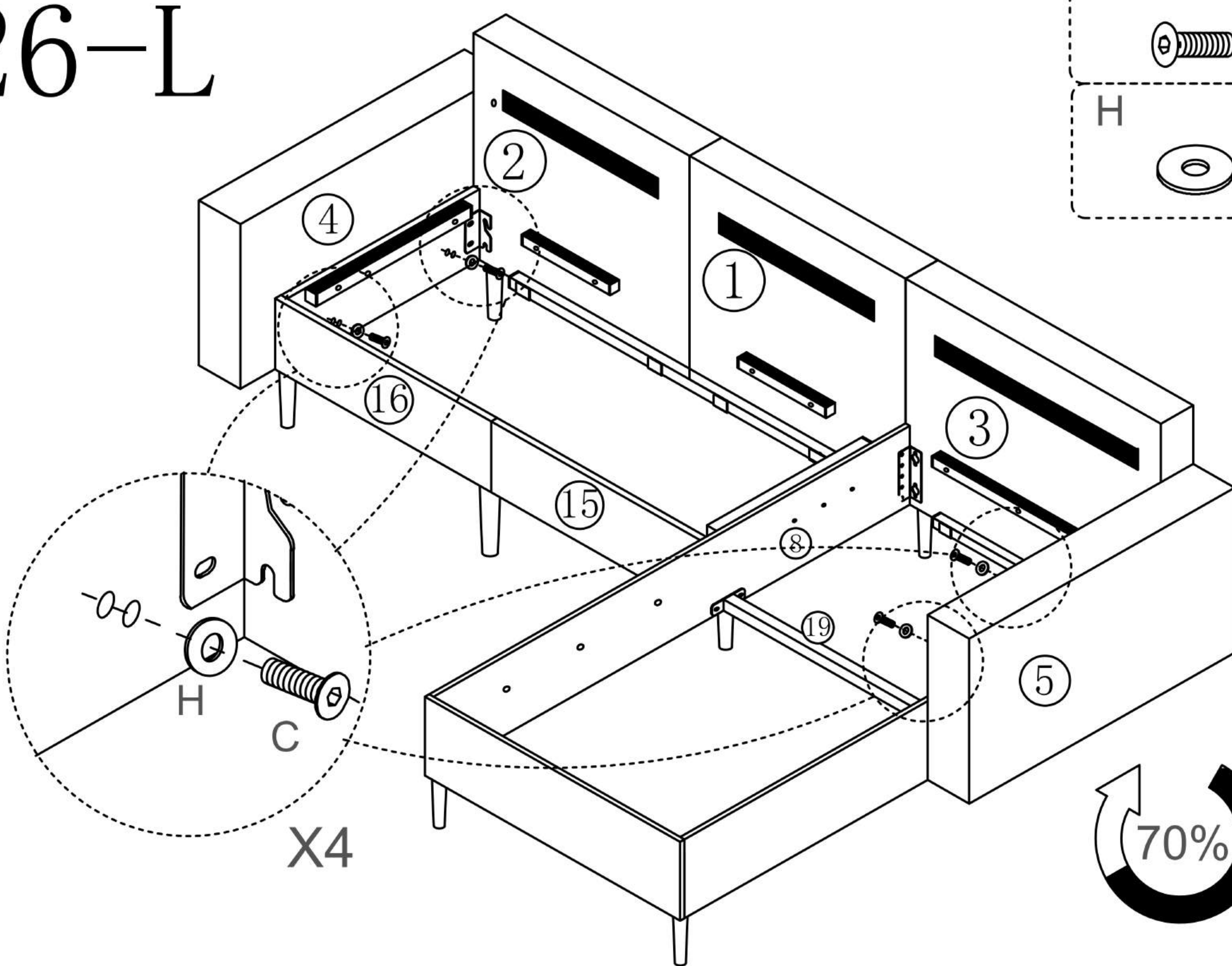

26-R

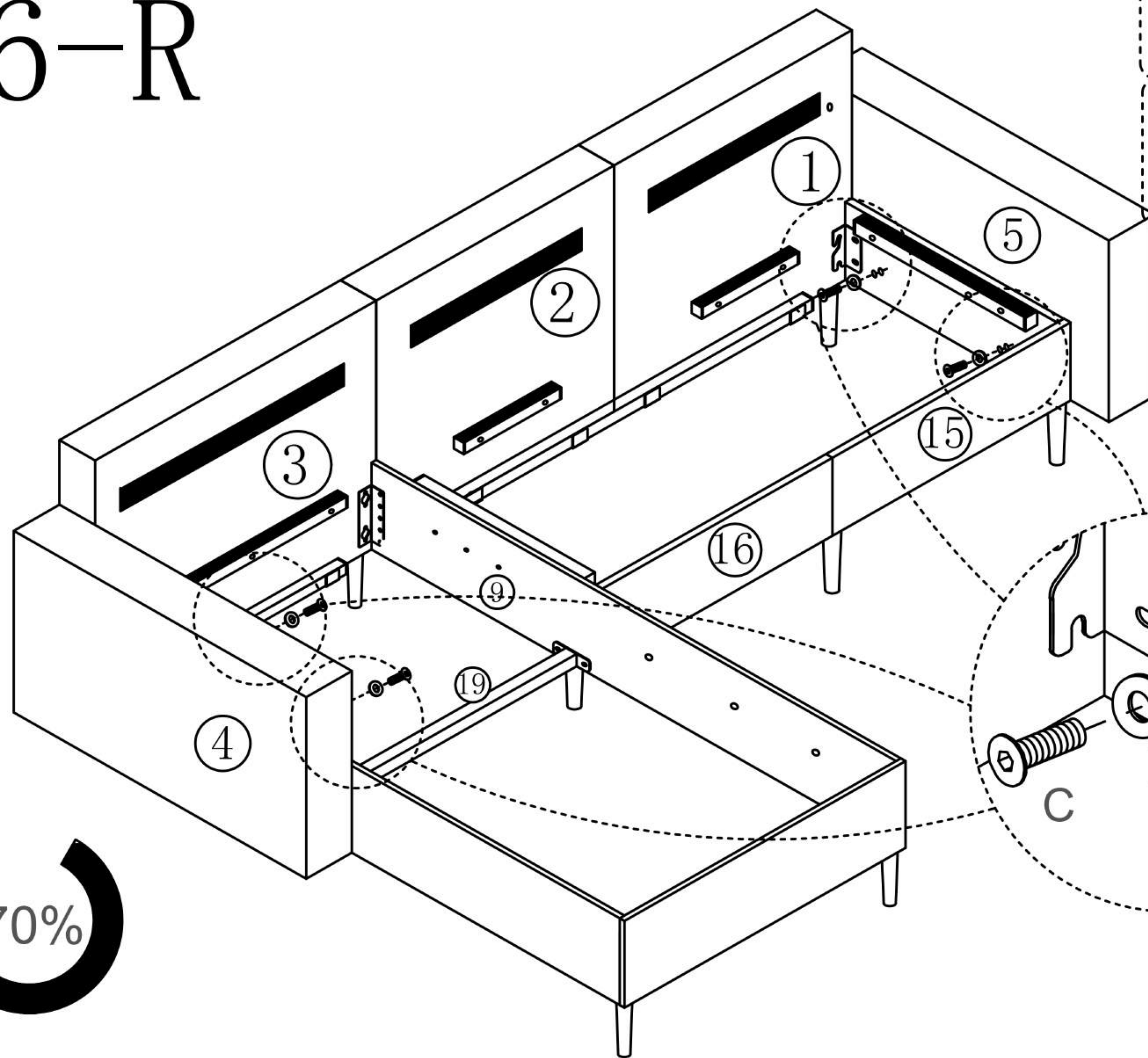

C M8*45



H

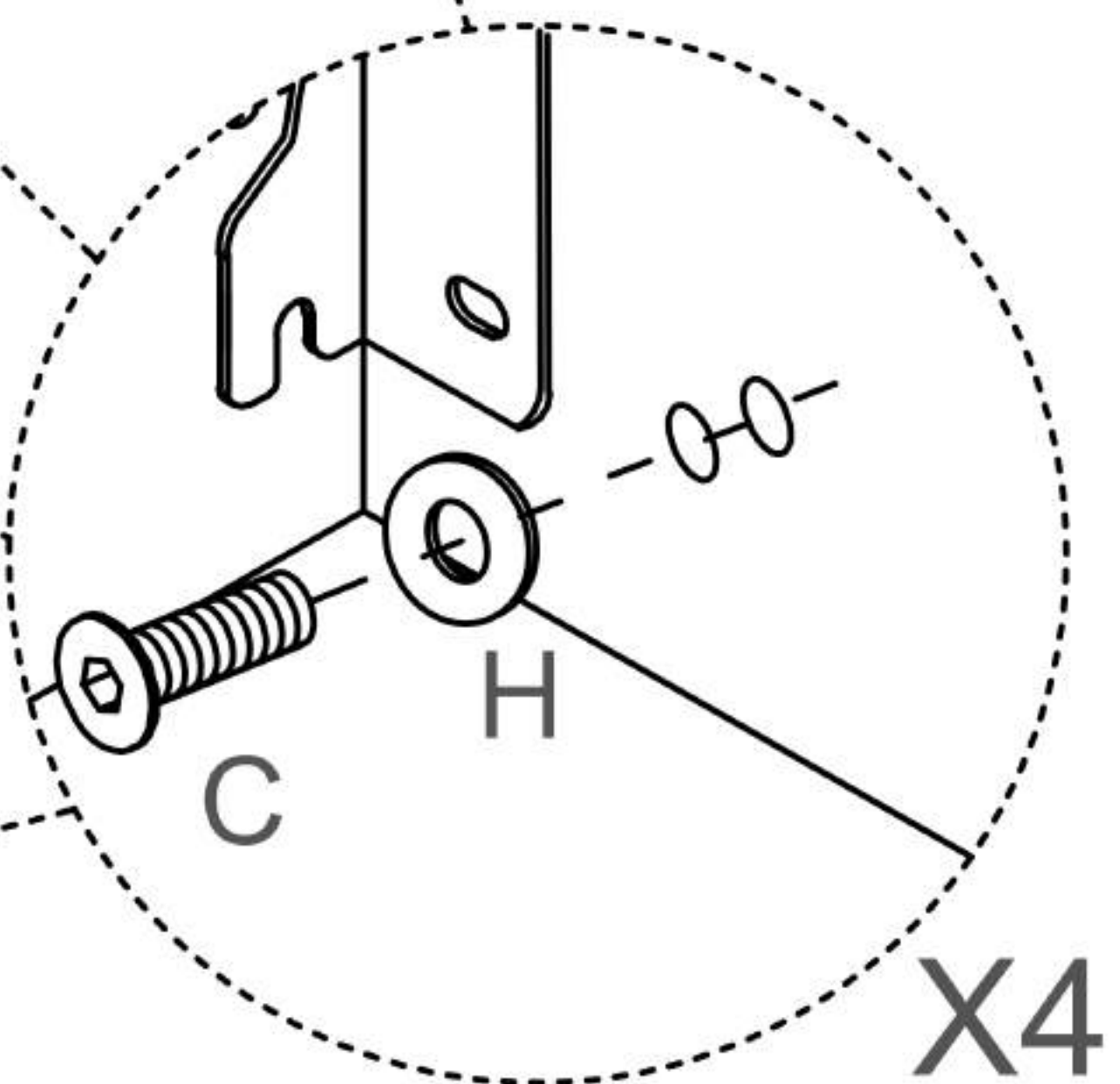

X4

27-L

DE: Bitte alle Schrauben festziehen.
 EN: Please tighten all the screws.
 FR: Veuillez serrer tous les vis.
 IT: Per favore, stringete tutti i viti.
 ES: Por favor, apriete todos los tornillos.

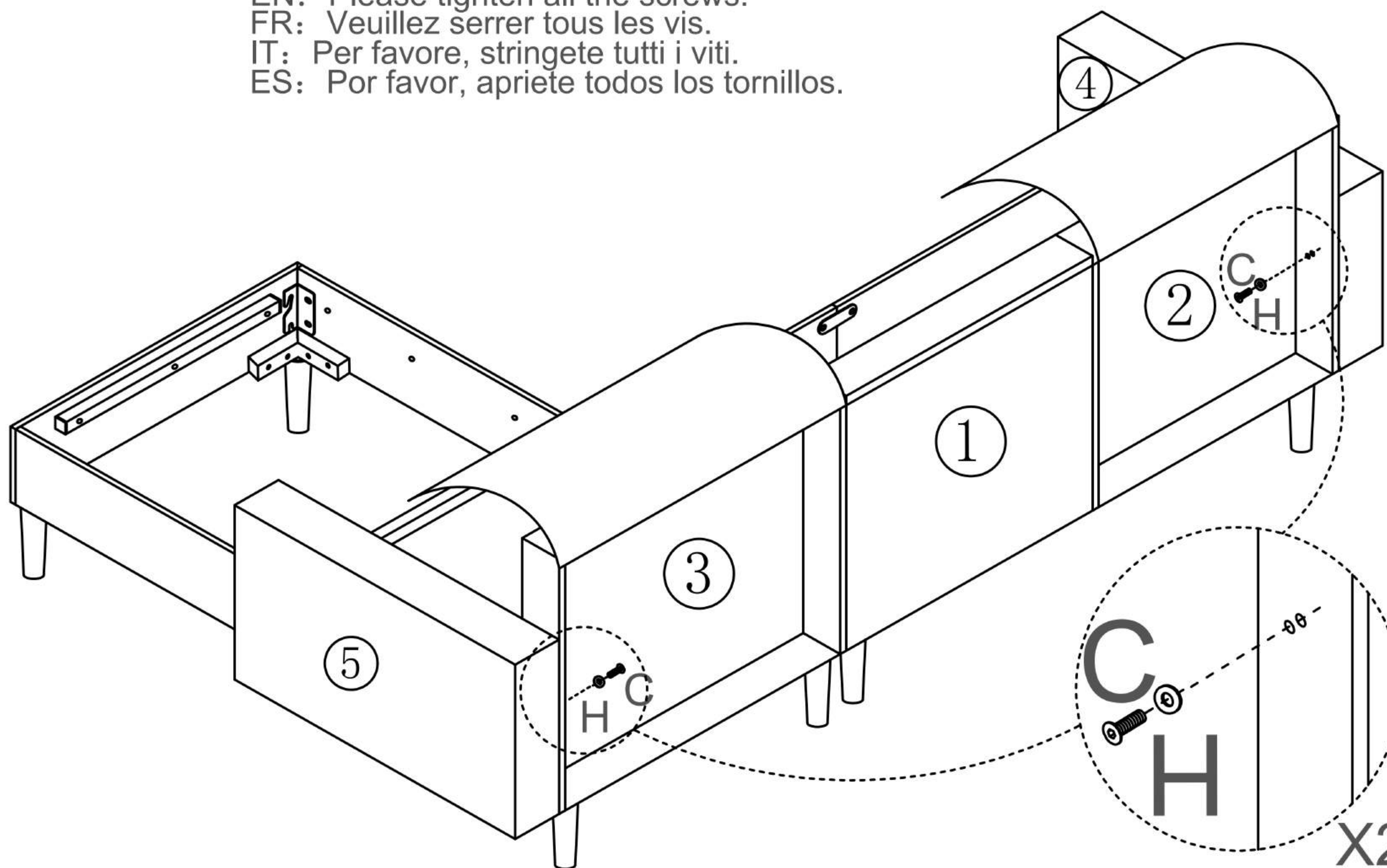

H



C M8*45

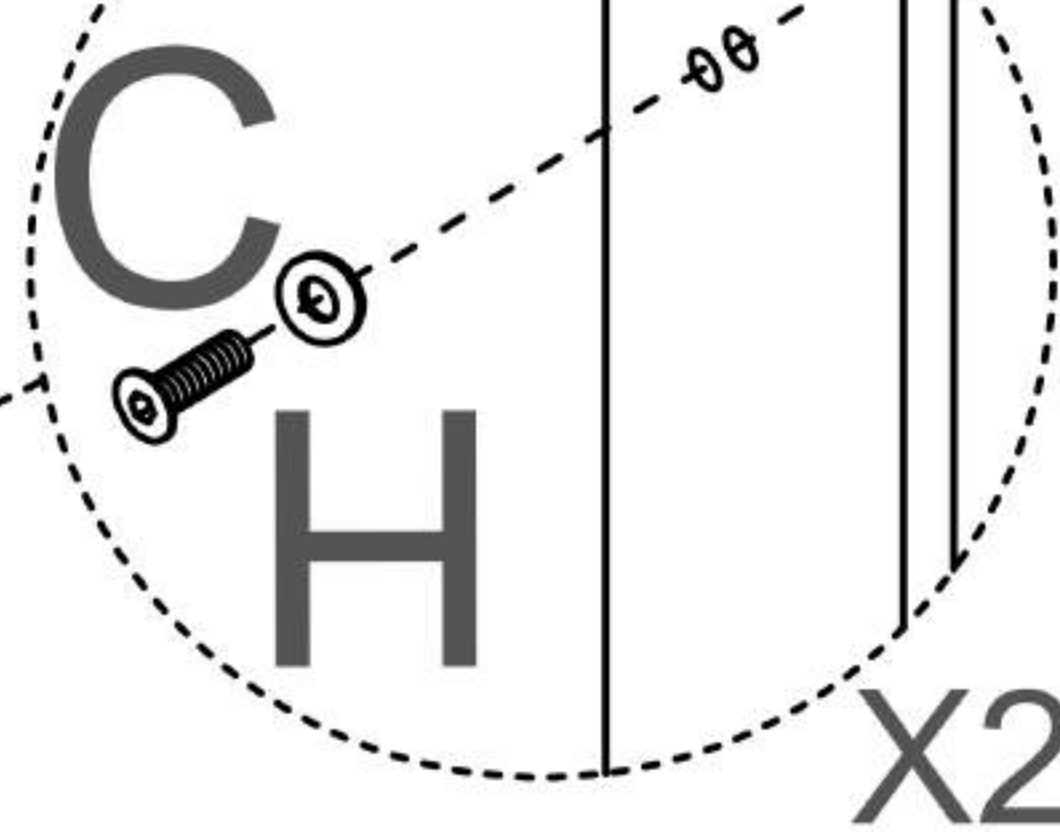

X2

27-R

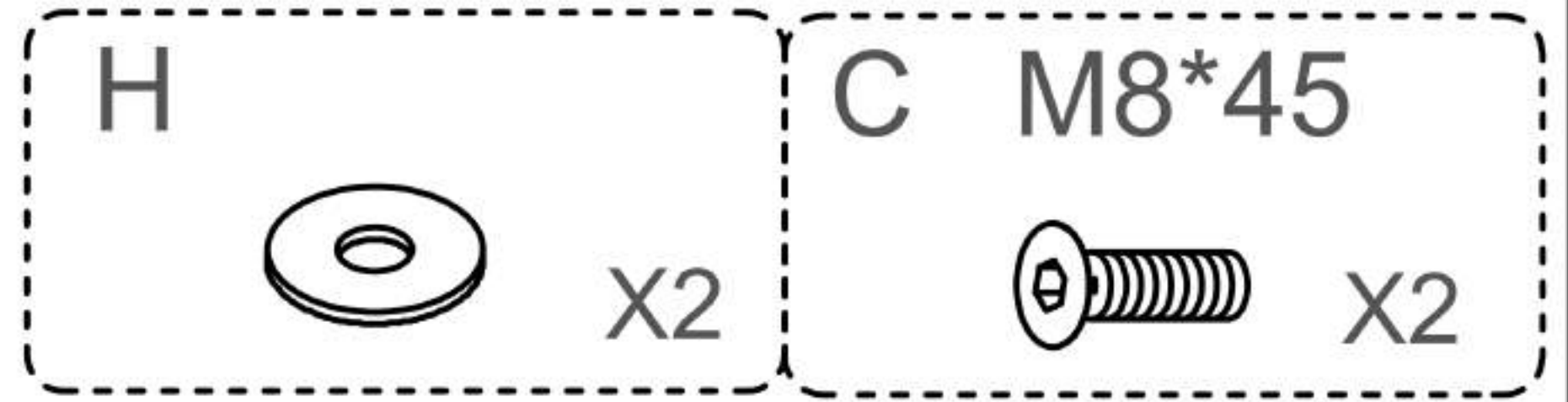

DE: Bitte alle Schrauben festziehen.
EN: Please tighten all the screws.
FR: Veuillez serrer tous les vis.
IT: Per favore, stringete tutti i viti.
ES: Por favor, apriete todos los tornillos.

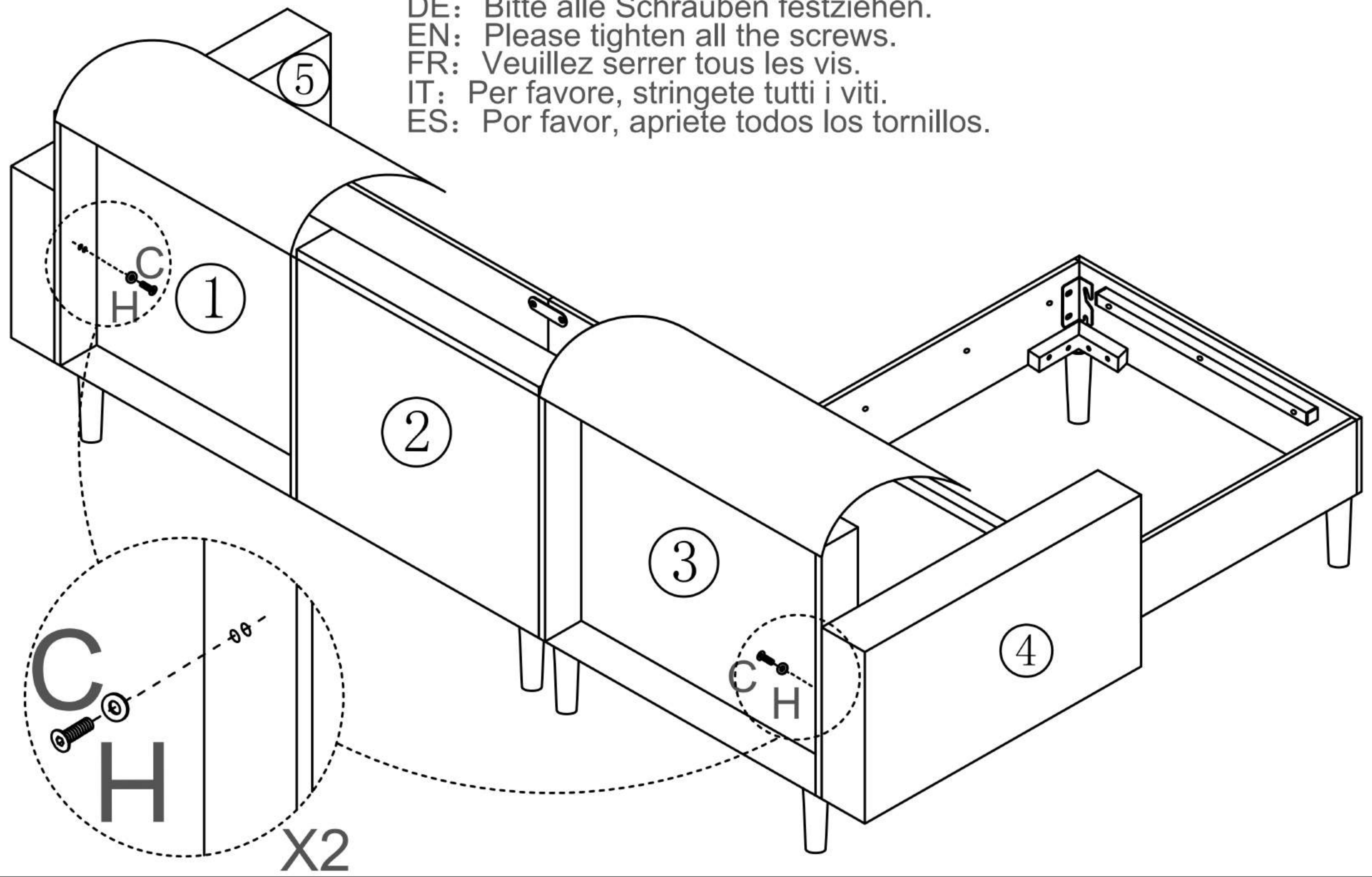

28

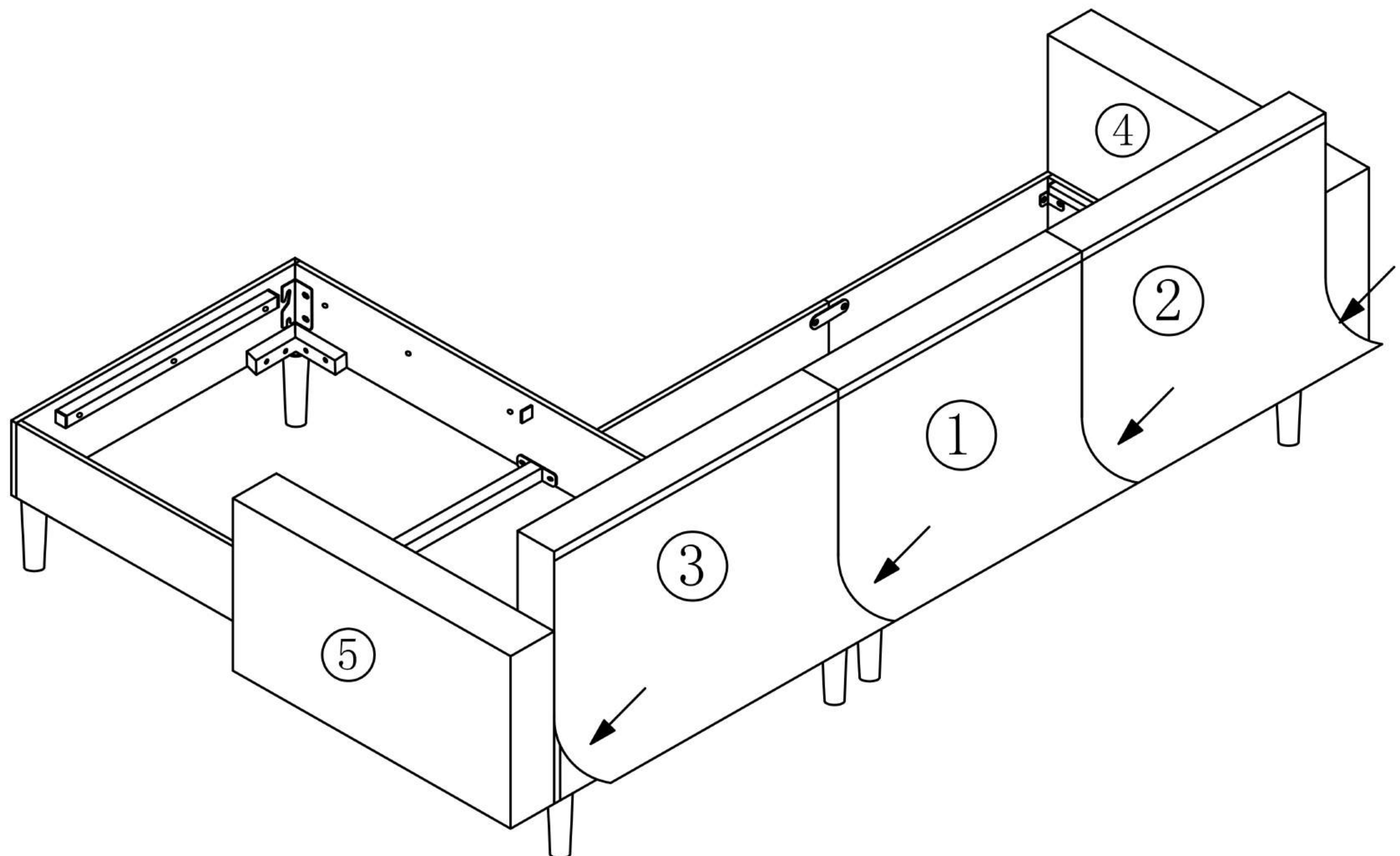

29

C M8*45

 X8

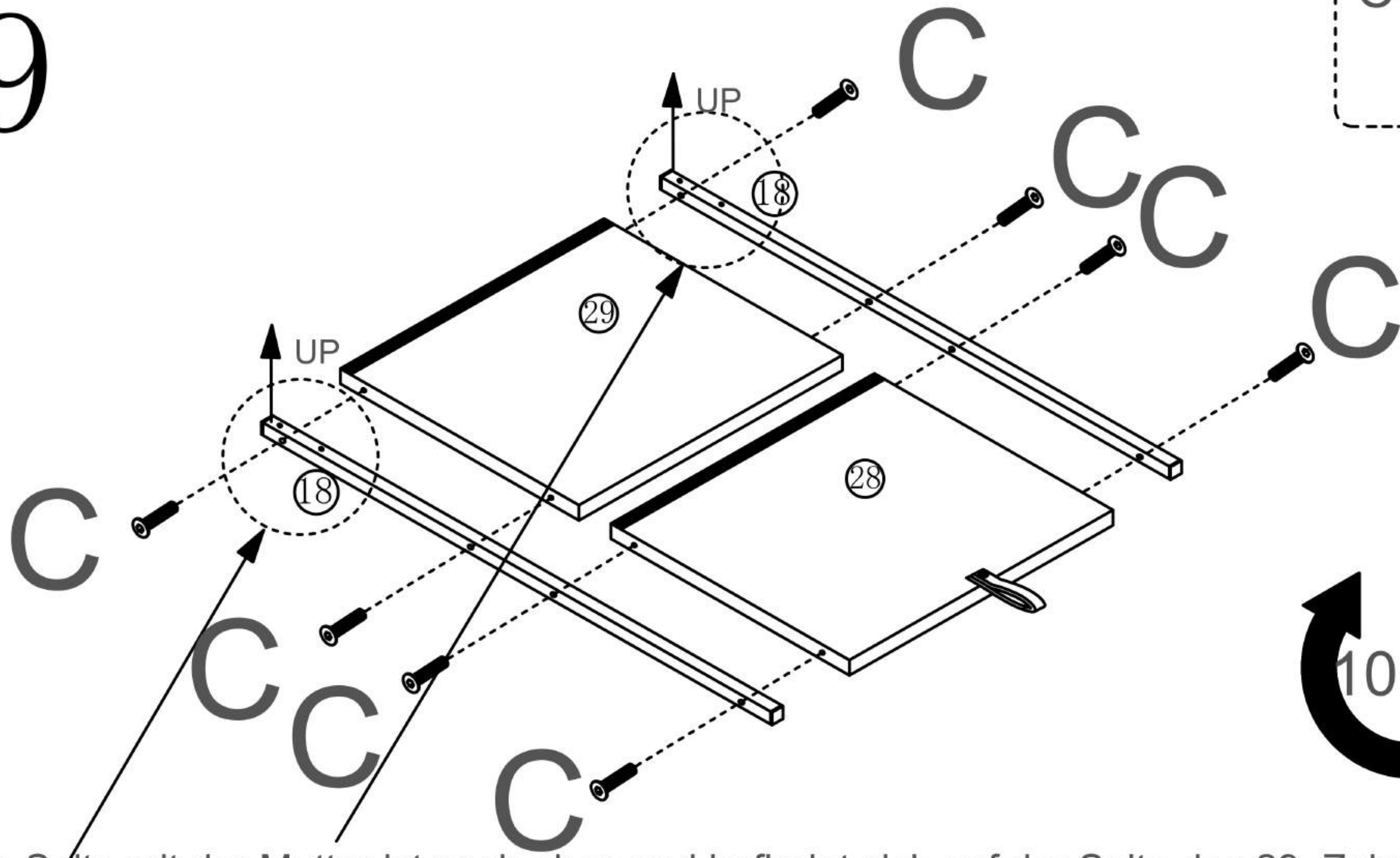

DE: Die Seite mit der Mutter ist nach oben und befindet sich auf der Seite des 29. Zubehörs.

EN: The side with the nut should face up and be placed on the 29th accessory.

FR: La face avec la vis est orientée vers le haut et placée côté accessoire n°29.

IT: La parte con la vite deve essere rivolta verso l'alto e posizionata di fronte all'accessorio numero 29.

ES: La cara con la tuerca debe estar hacia arriba y colocada junto al accesorio número 29.

DE: Die Seiten mit der Feder auf den 28. und 29. Zubehörteilen sind nach unten gerichtet.

EN: For parts 28 and 29, the side with the spring should face down.

FR: Les pièces 28 et 29 doivent avoir le côté à ressort vers le bas.

IT: I componenti 28 e 29 devono avere la parte con la molla rivolta verso il basso.

ES: Las piezas 28 y 29 tienen el lado con resorte hacia abajo.

30-L

F M6*20

 X6

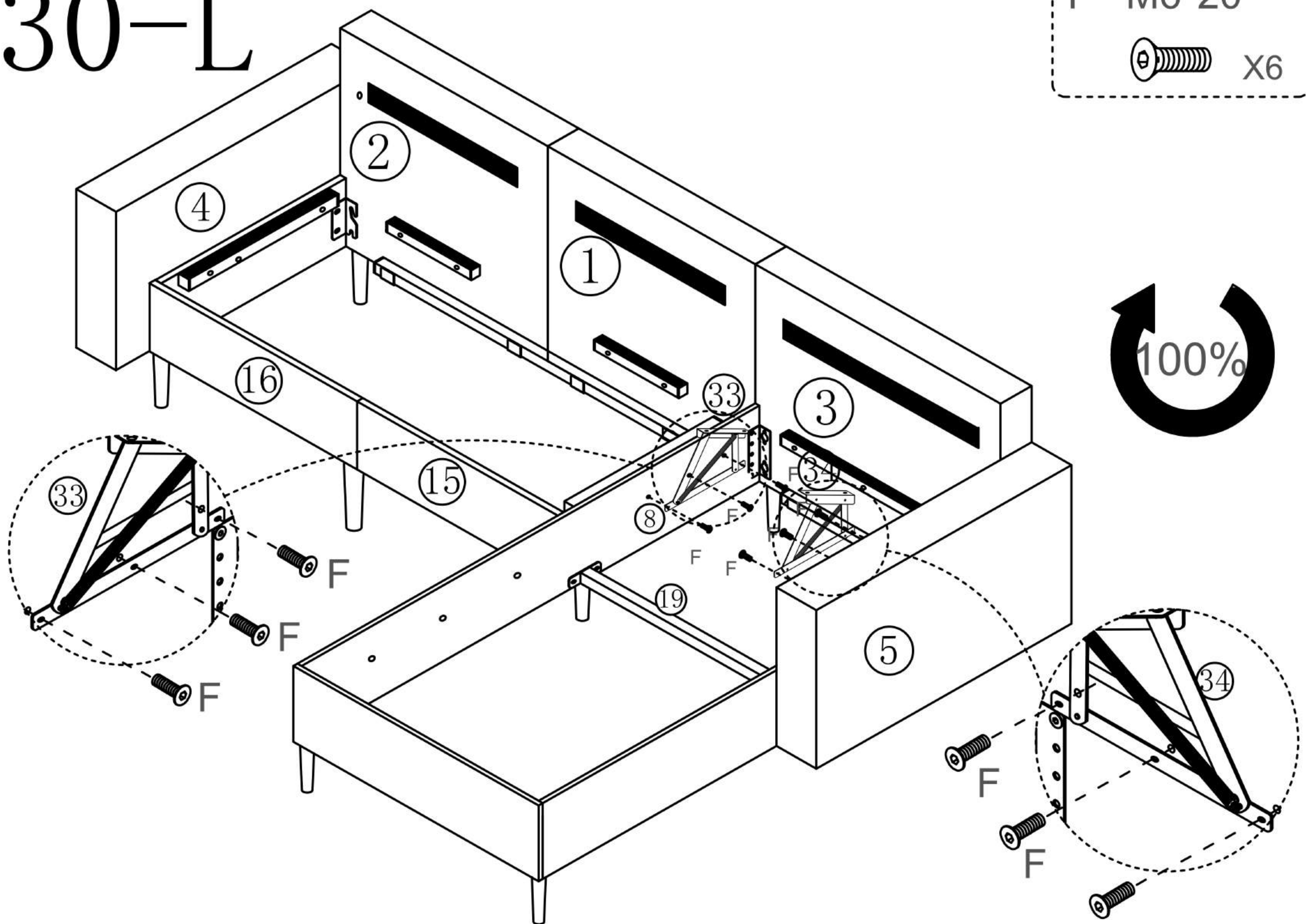

30-R

F M6*20
X6

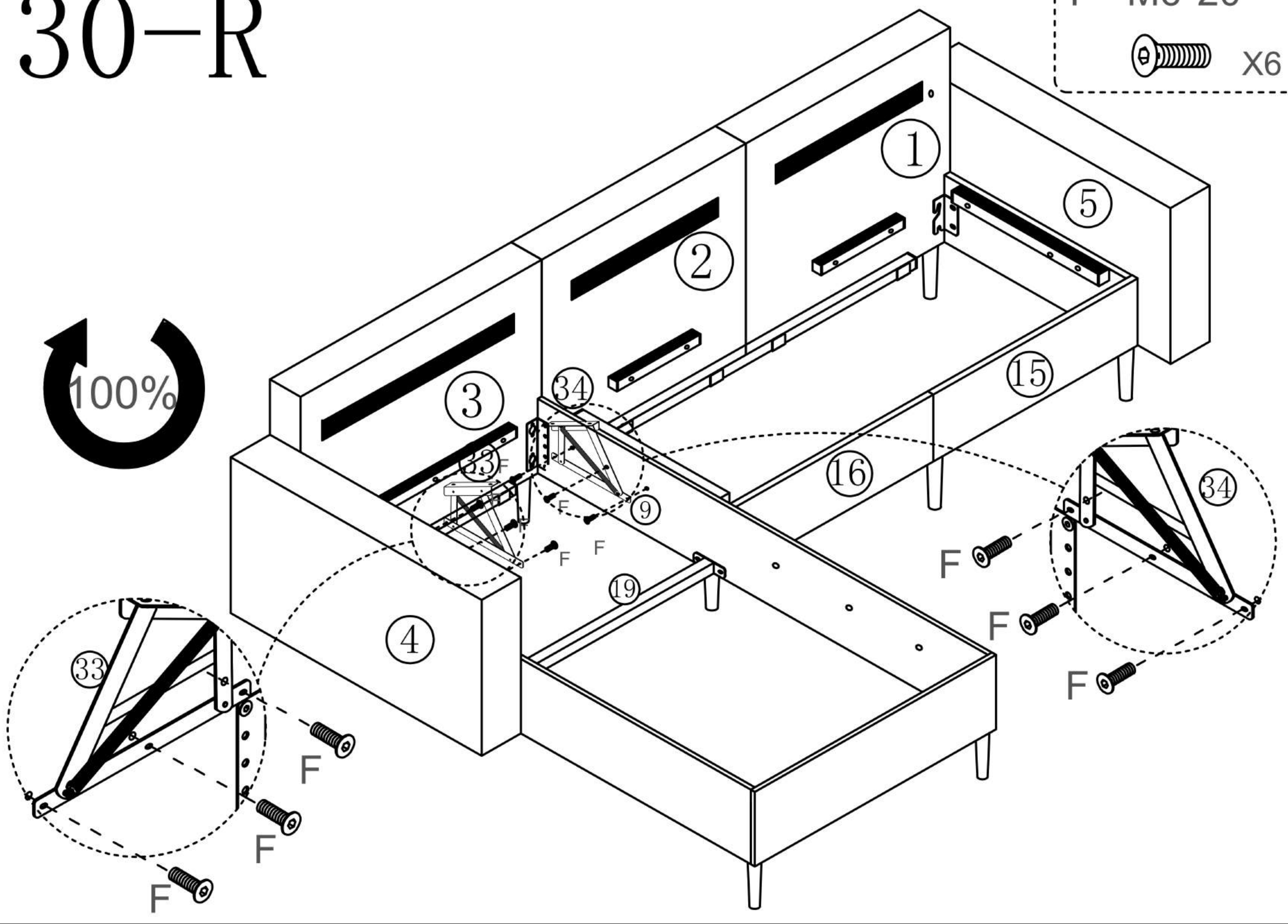
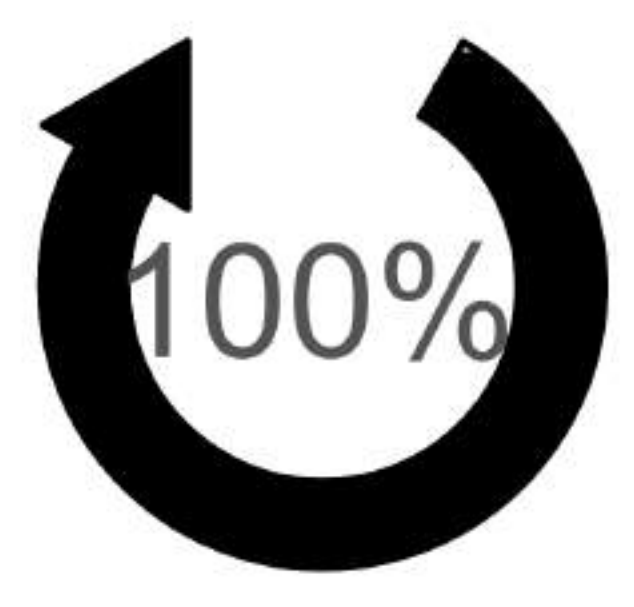

31-L

E M6*20
X4

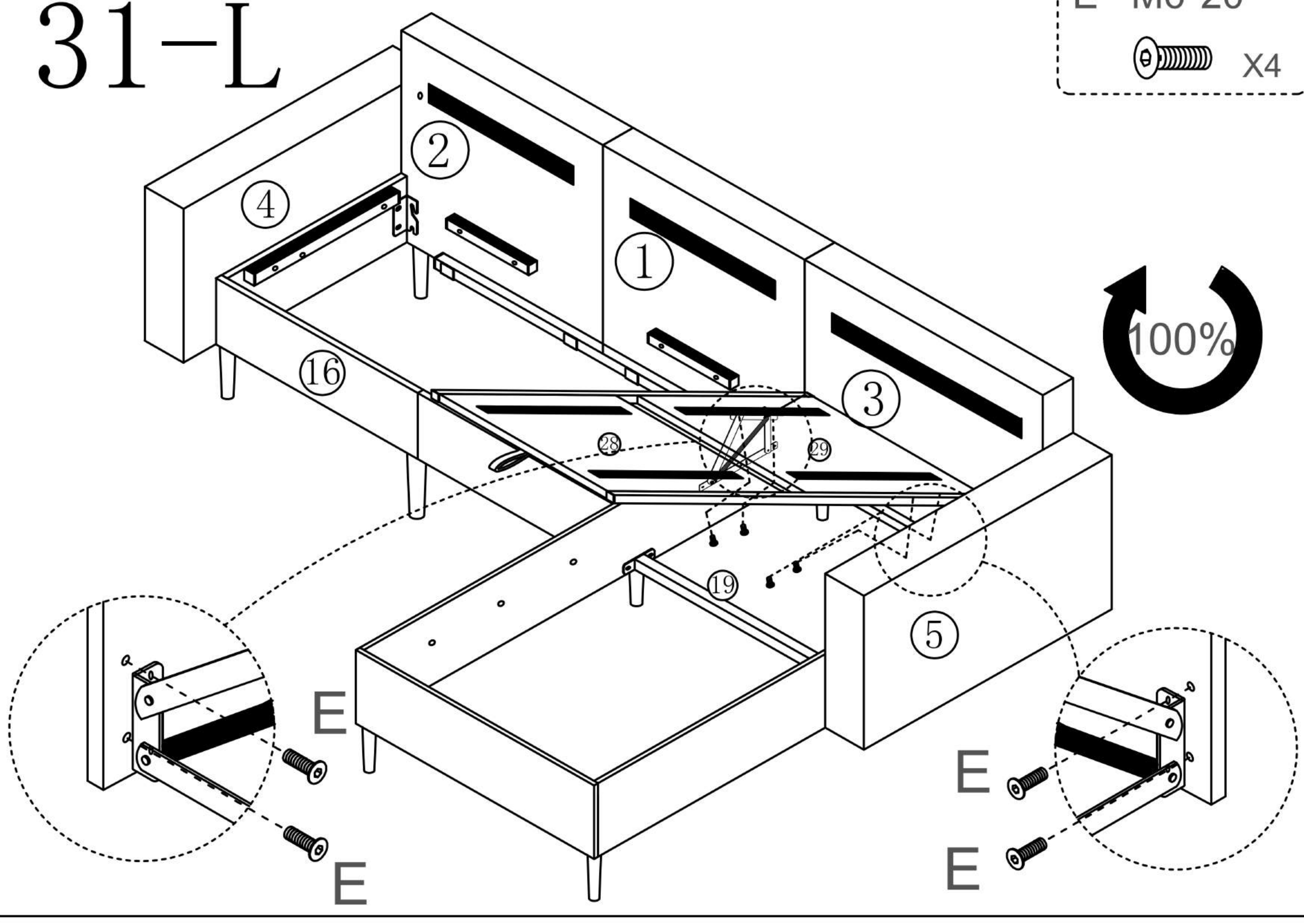
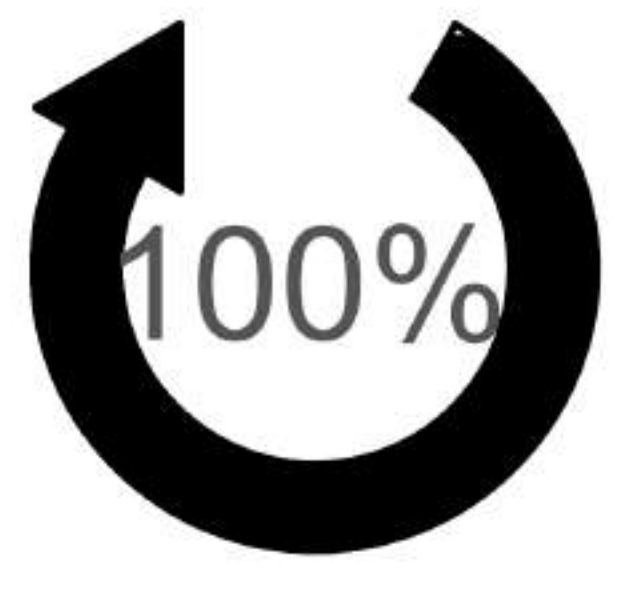

31-R

E M6*20

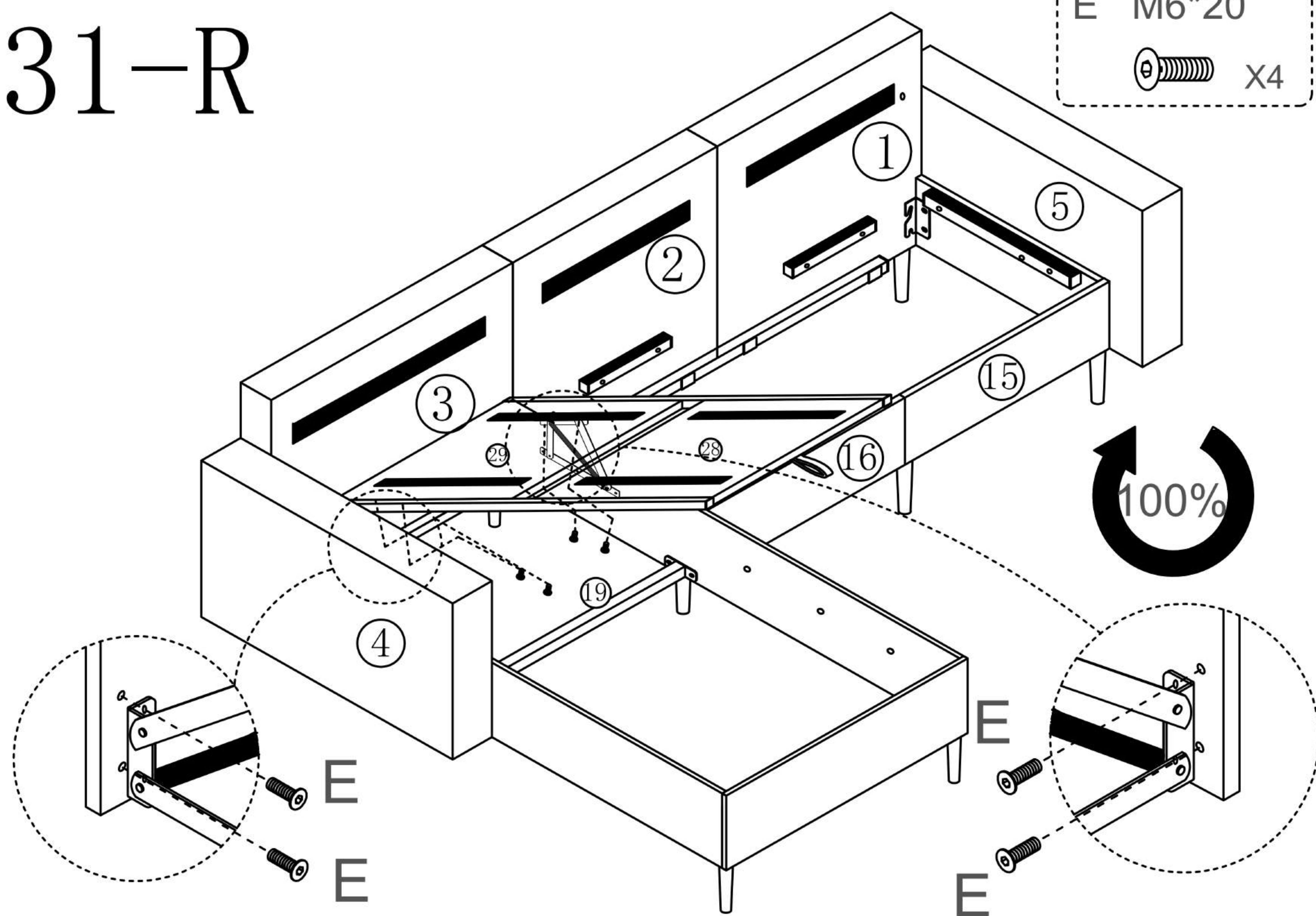

32-L

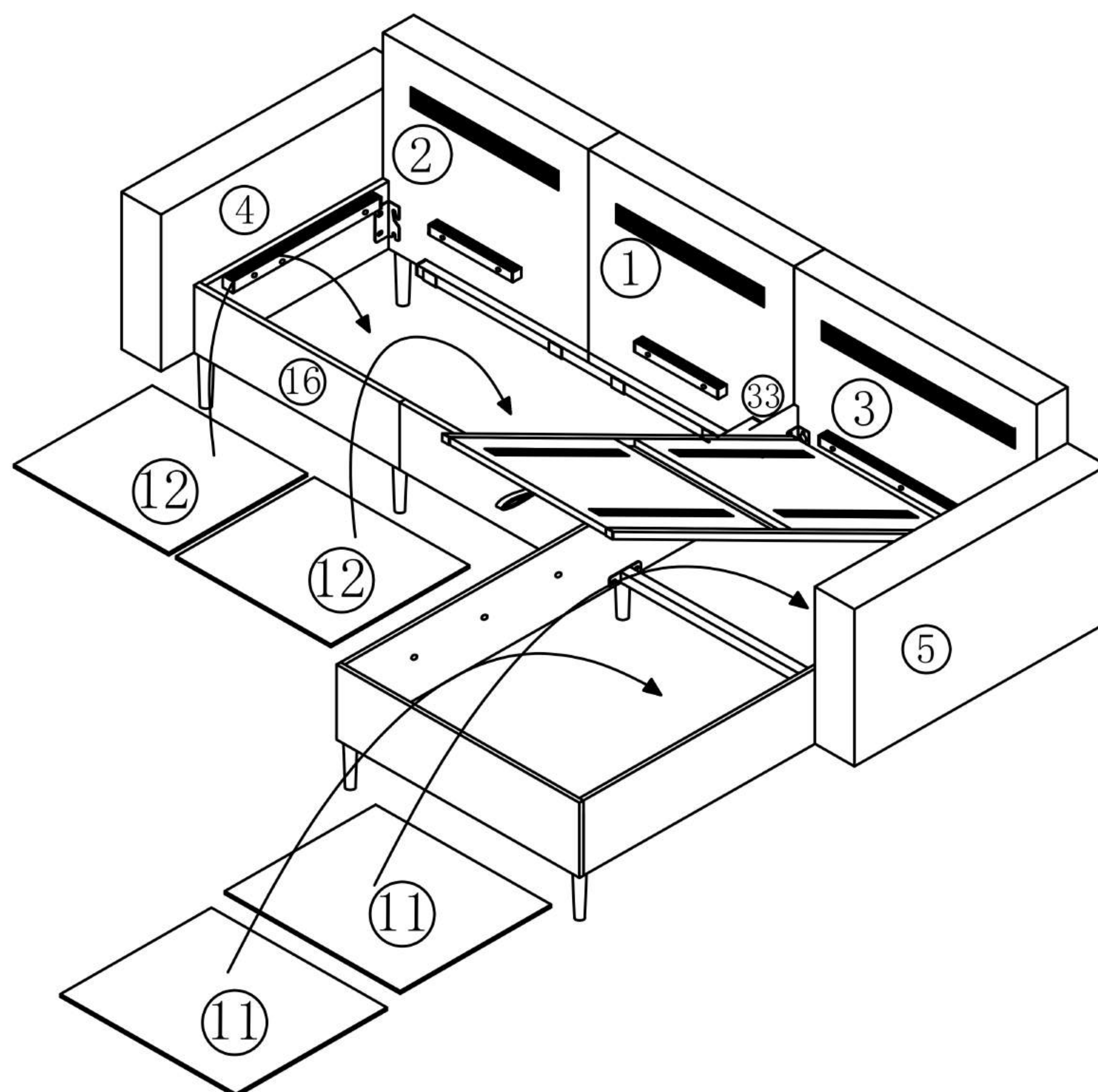

32-R

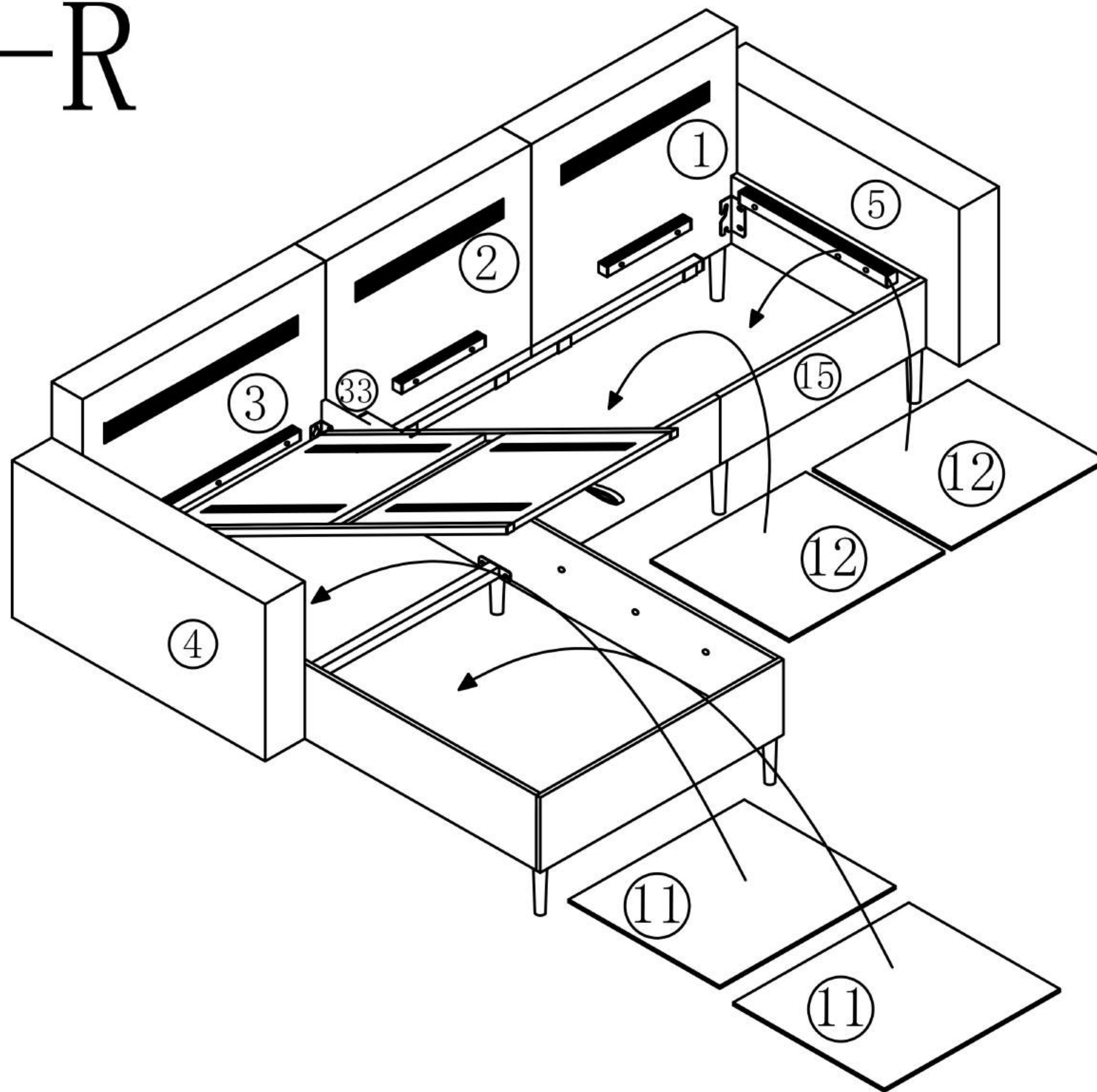

33

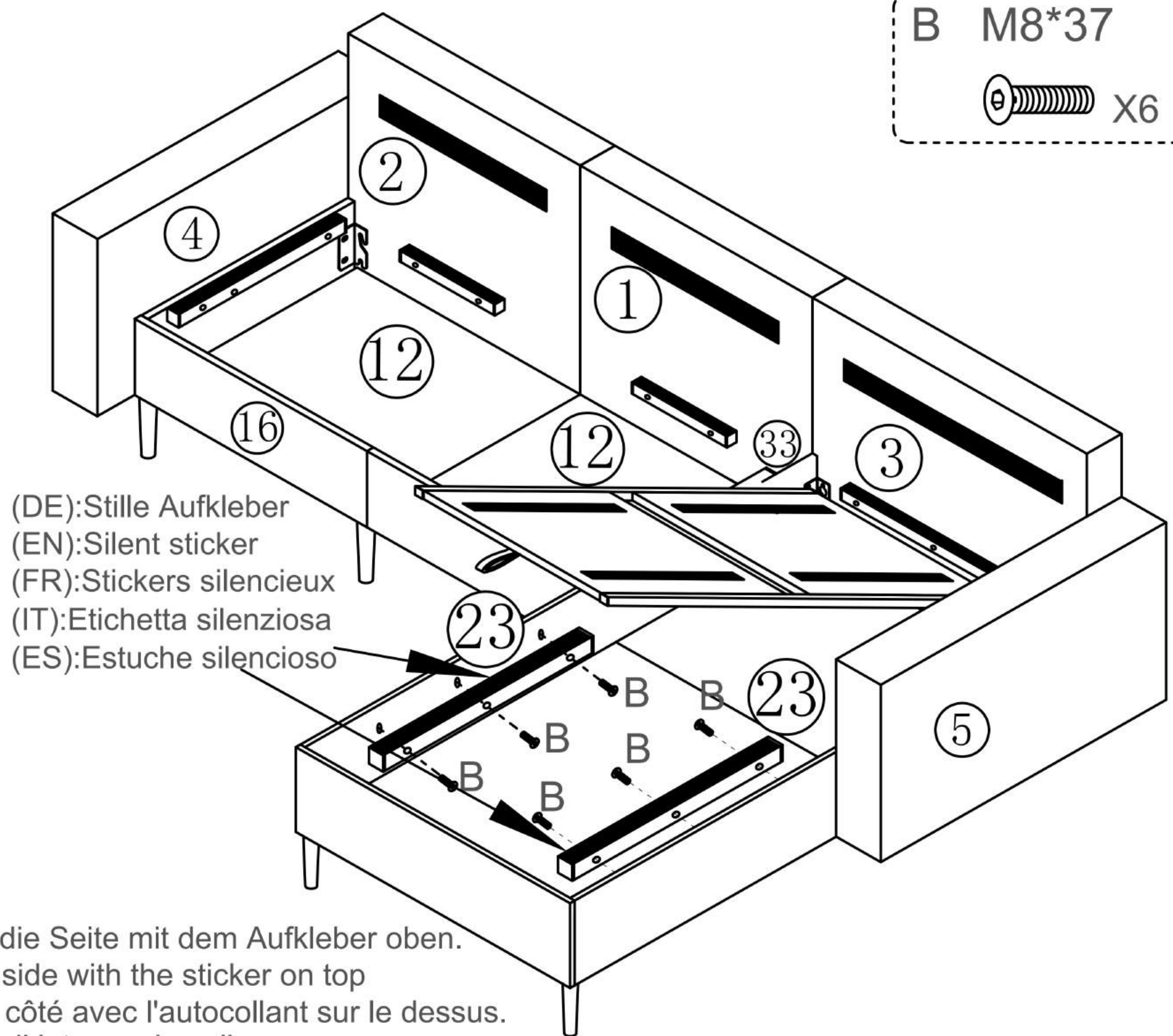
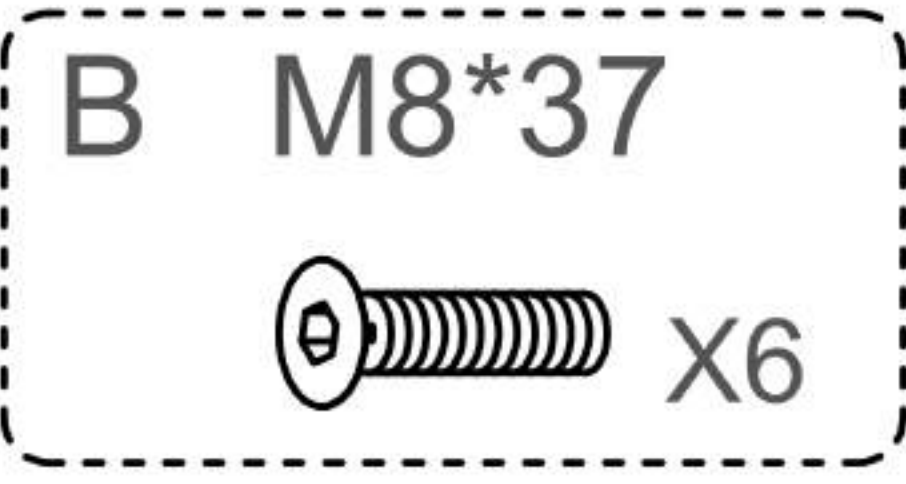

(DE):Stille Aufkleber
 (EN):Silent sticker
 (FR):Stickers silencieux
 (IT):Etichetta silenziosa
 (ES):Estuche silencioso

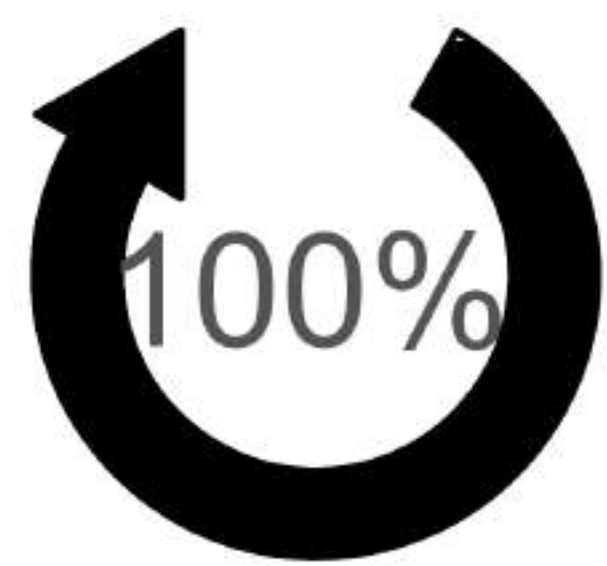

DE: Bitte montieren Sie die Seite mit dem Aufkleber oben.
 EN:Please assemble the side with the sticker on top
 FR:Veuillez assembler le côté avec l'autocollant sur le dessus.
 IT:Si prega di assemblare il lato con la colla sopra.
 ES:Por favor, ensamble el lado con la etiqueta en la parte superior.

34

C M8*45



38

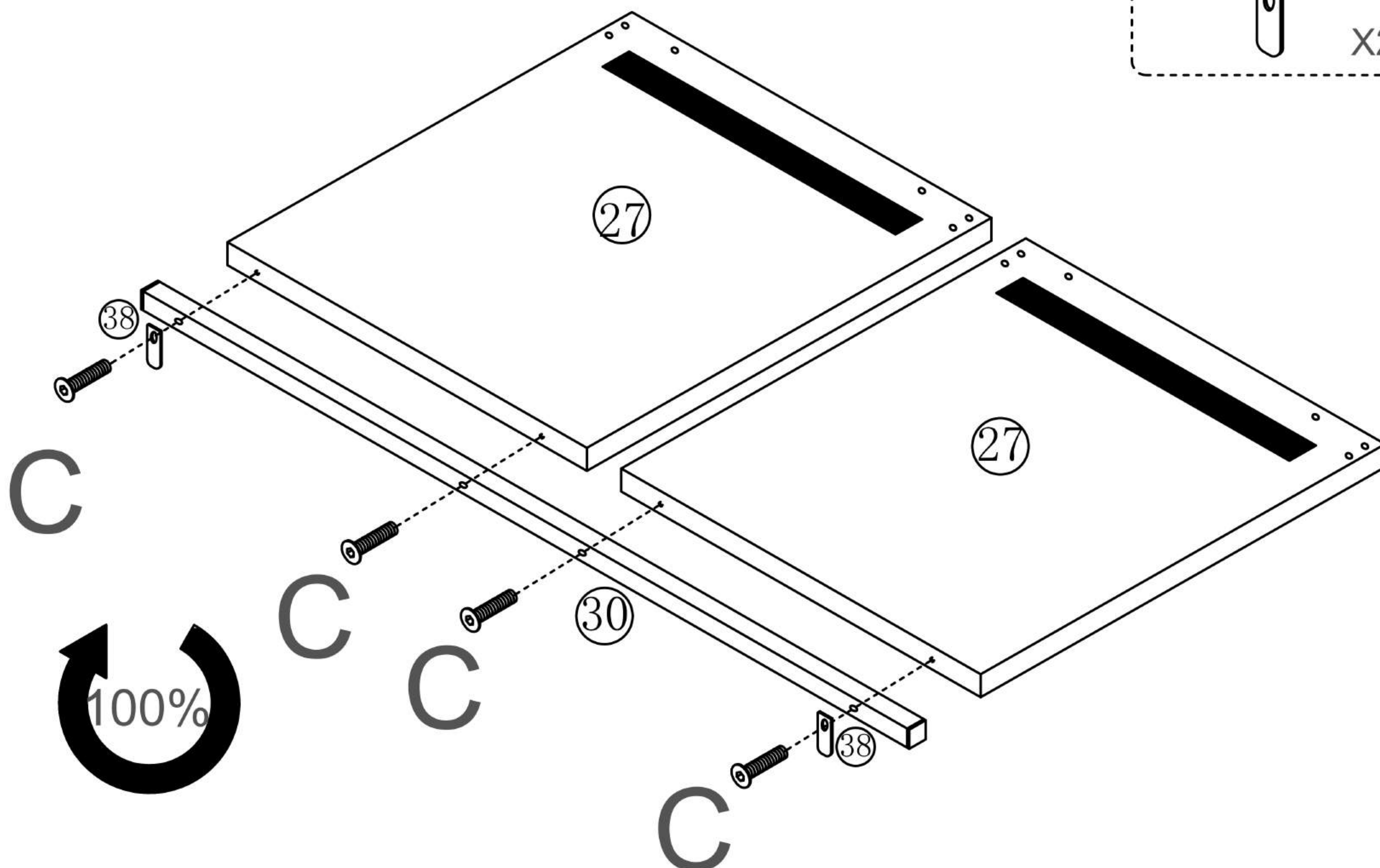

35

B M8*37



DE: Die Seite mit der Mutter nach oben.
EN: The side with the nuts should face up.
FR: La face avec la vis est orientée vers le haut.
IT: La faccia con la vite è rivolta verso l'alto.
ES: La cara con la tuerca hacia arriba.

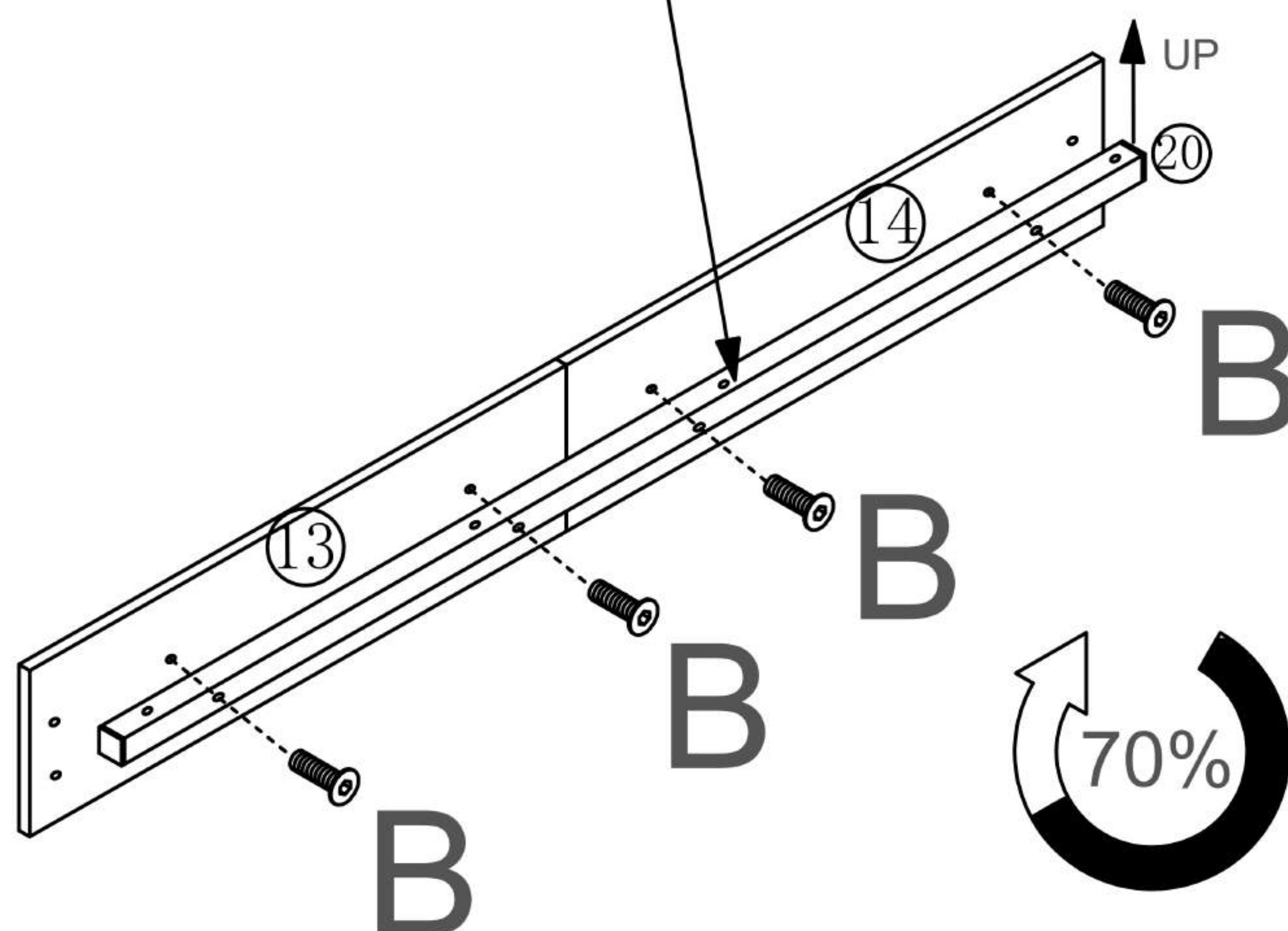

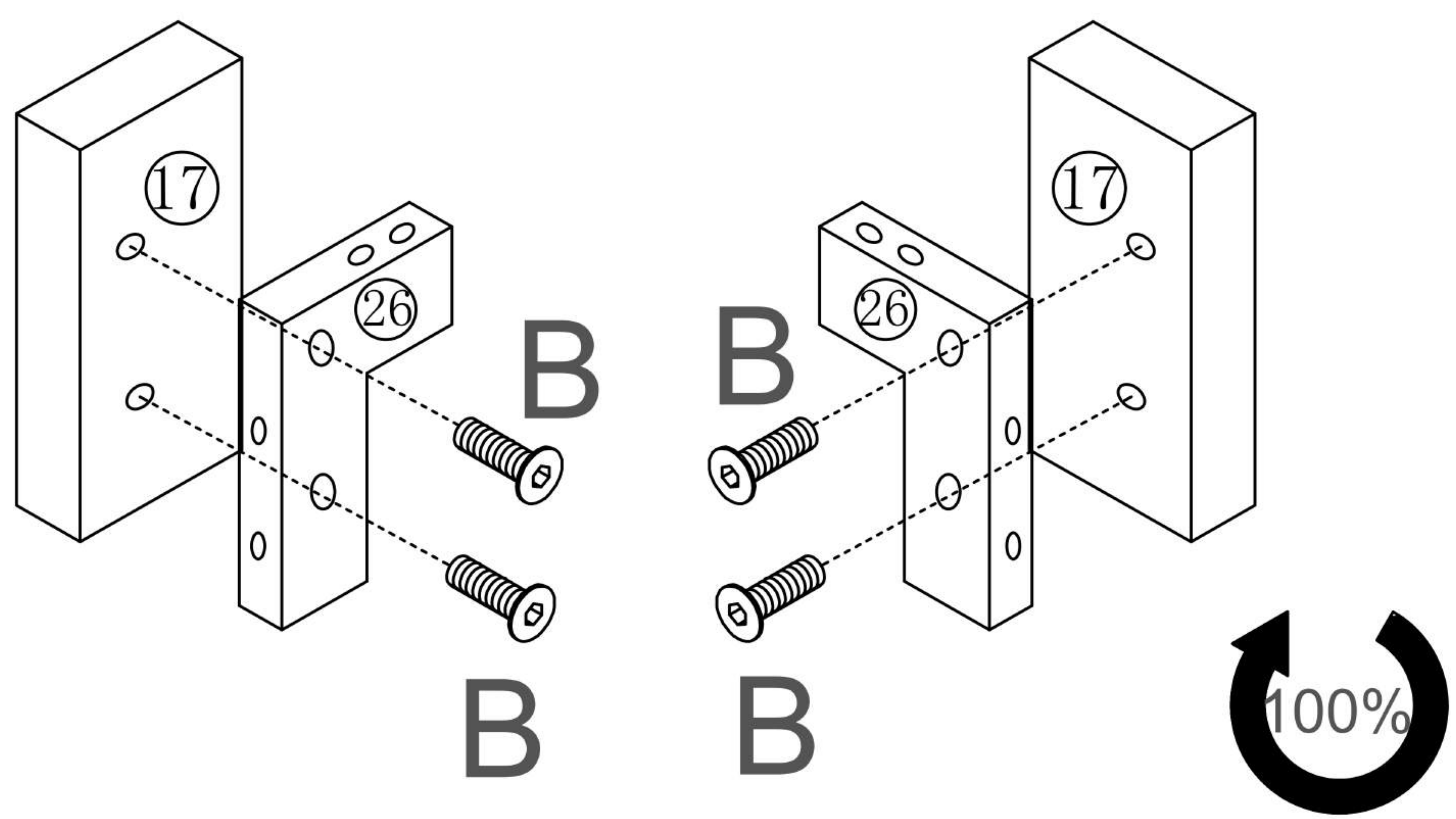

36

B M8*37
 X4

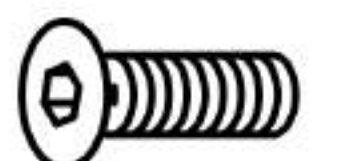

37

A M8*16
 X2

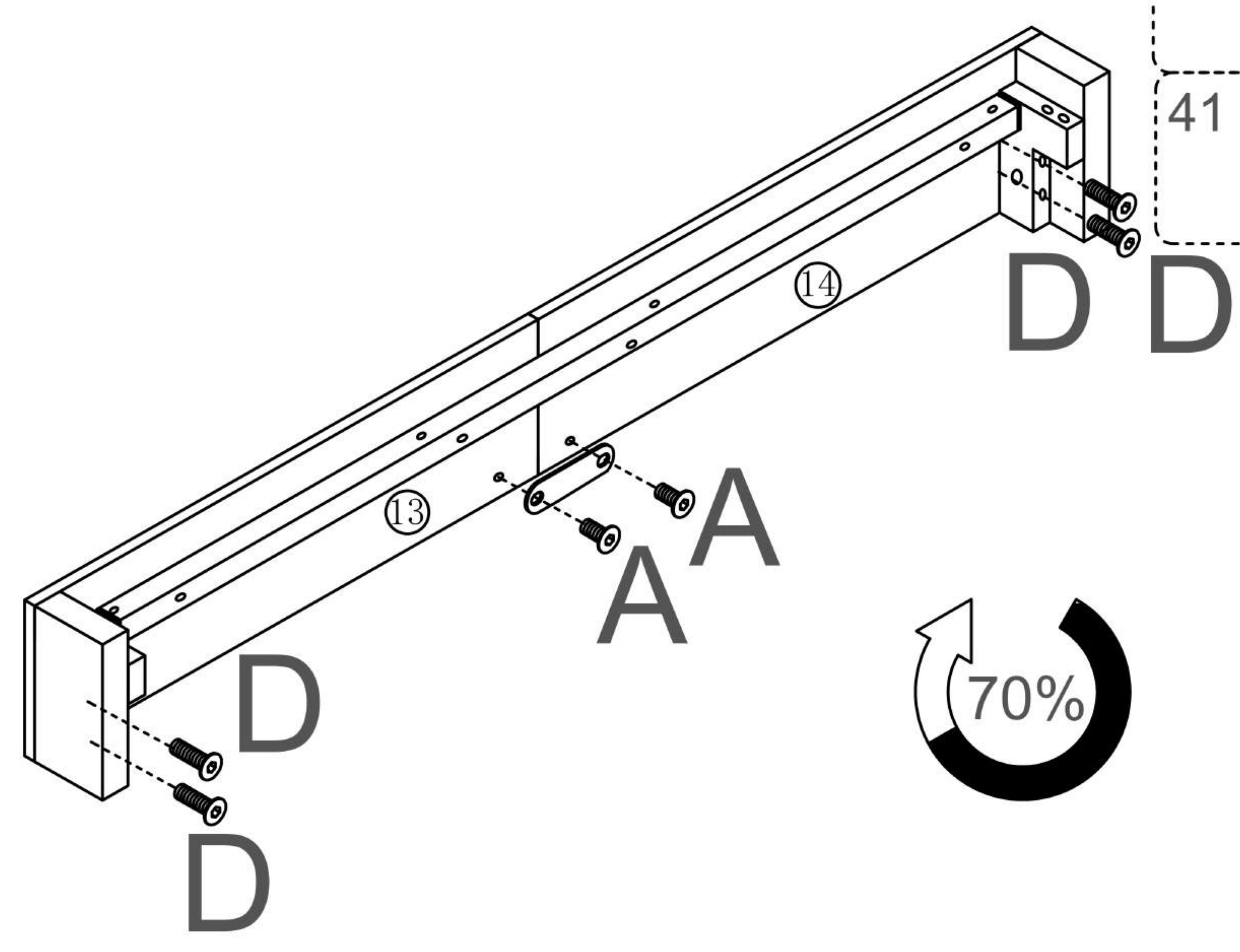

D M8*55
 X4

41
 X1

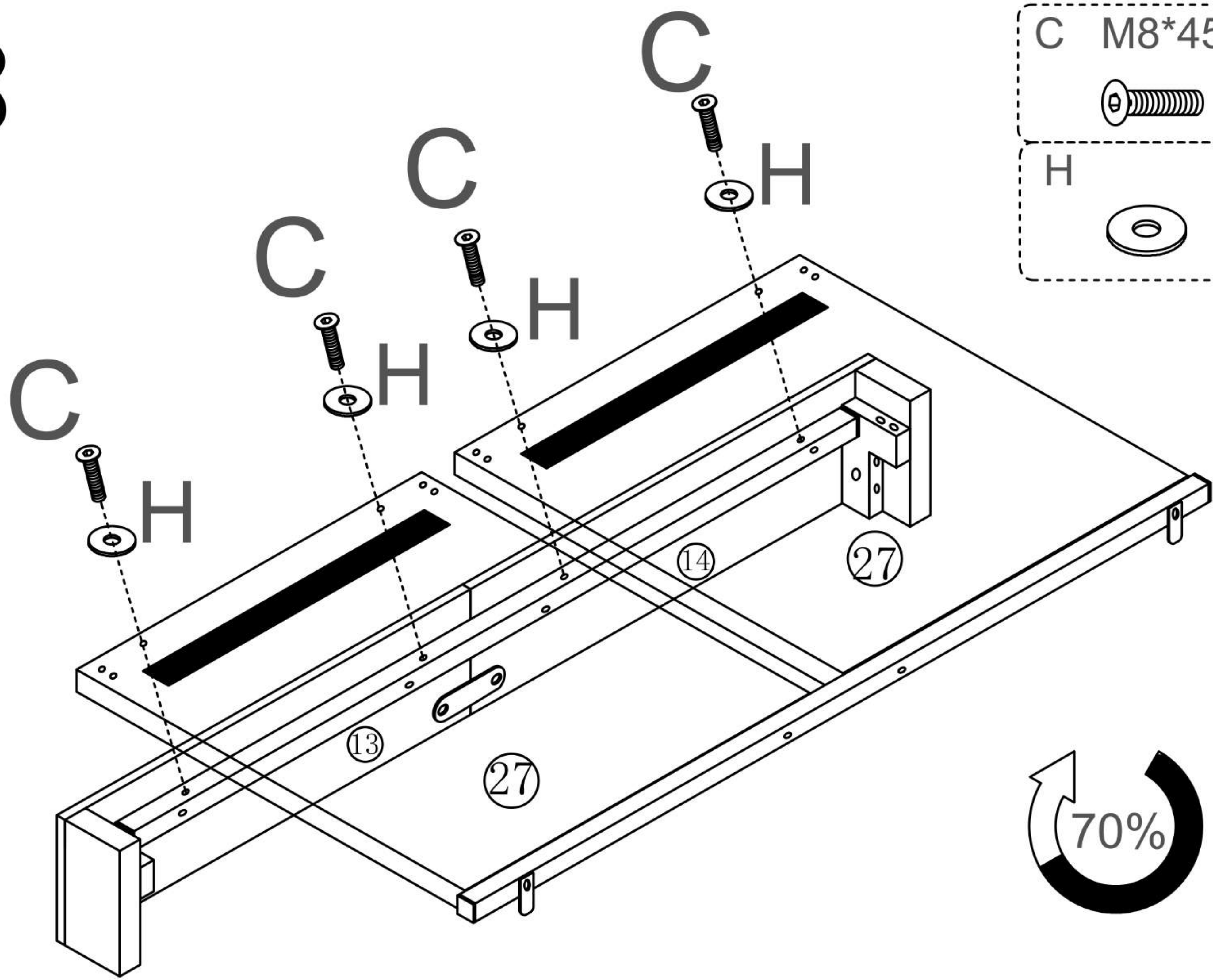

38

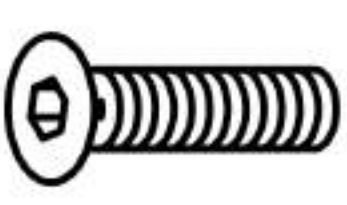

- C M8*45
 X4
- H
 X4



39

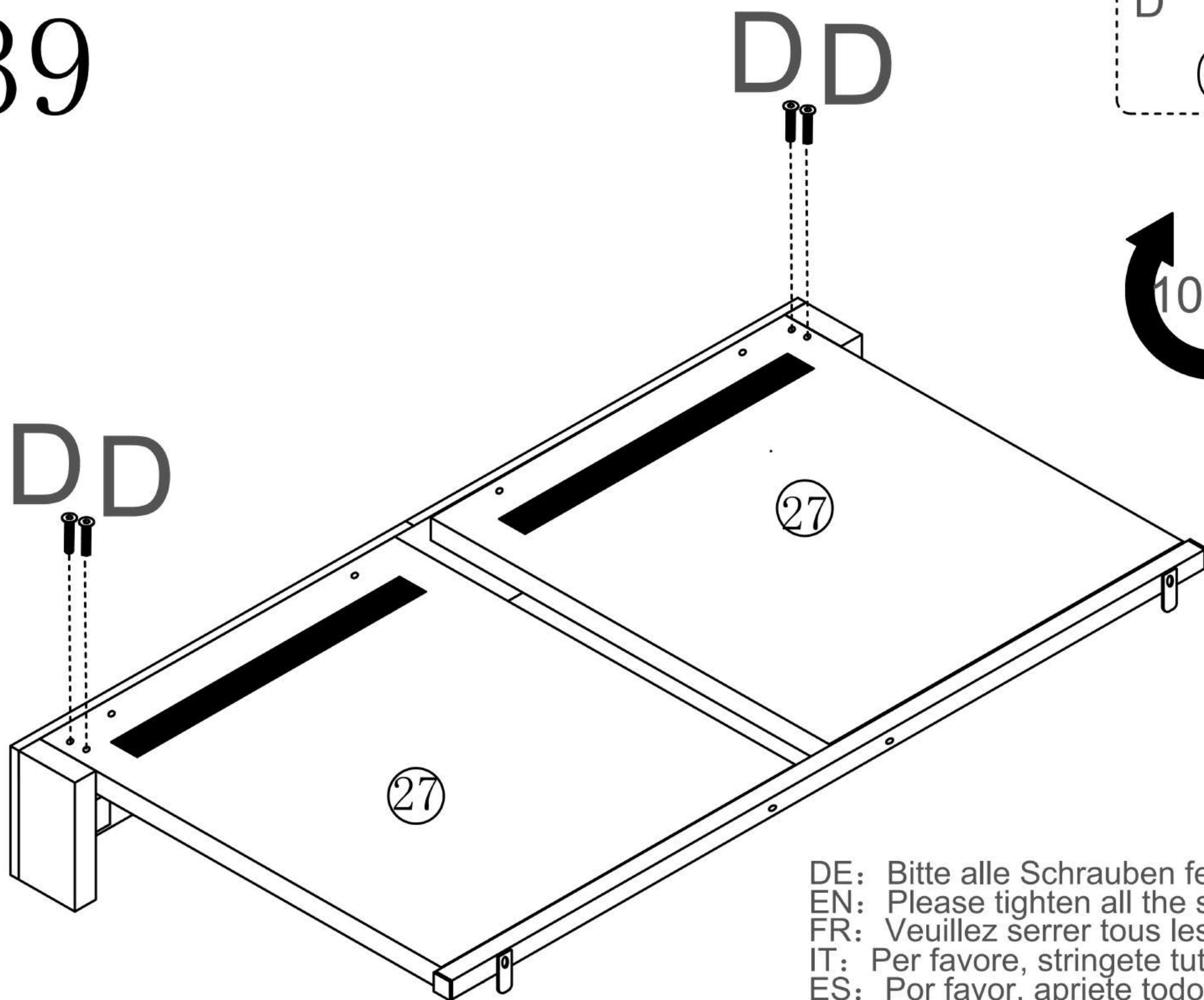

- D M8*55
 X4

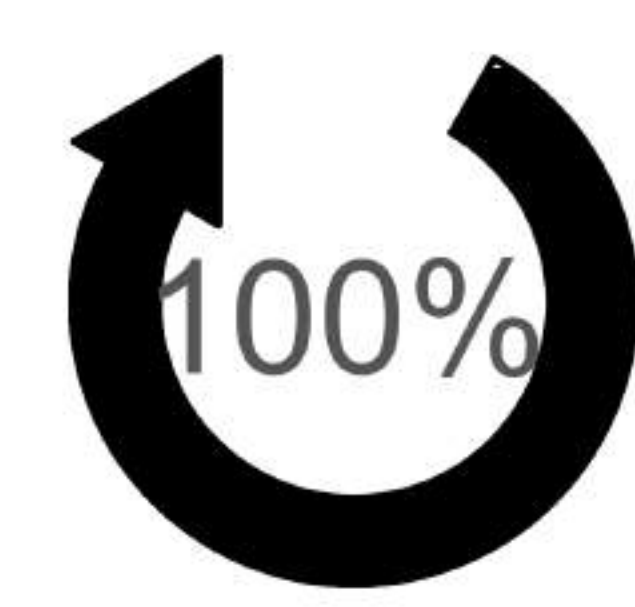

DE: Bitte alle Schrauben festziehen.
 EN: Please tighten all the screws.
 FR: Veuillez serrer tous les vis.
 IT: Per favore, stringete tutti i viti.
 ES: Por favor, apriete todos los tornillos.

40

37 X2

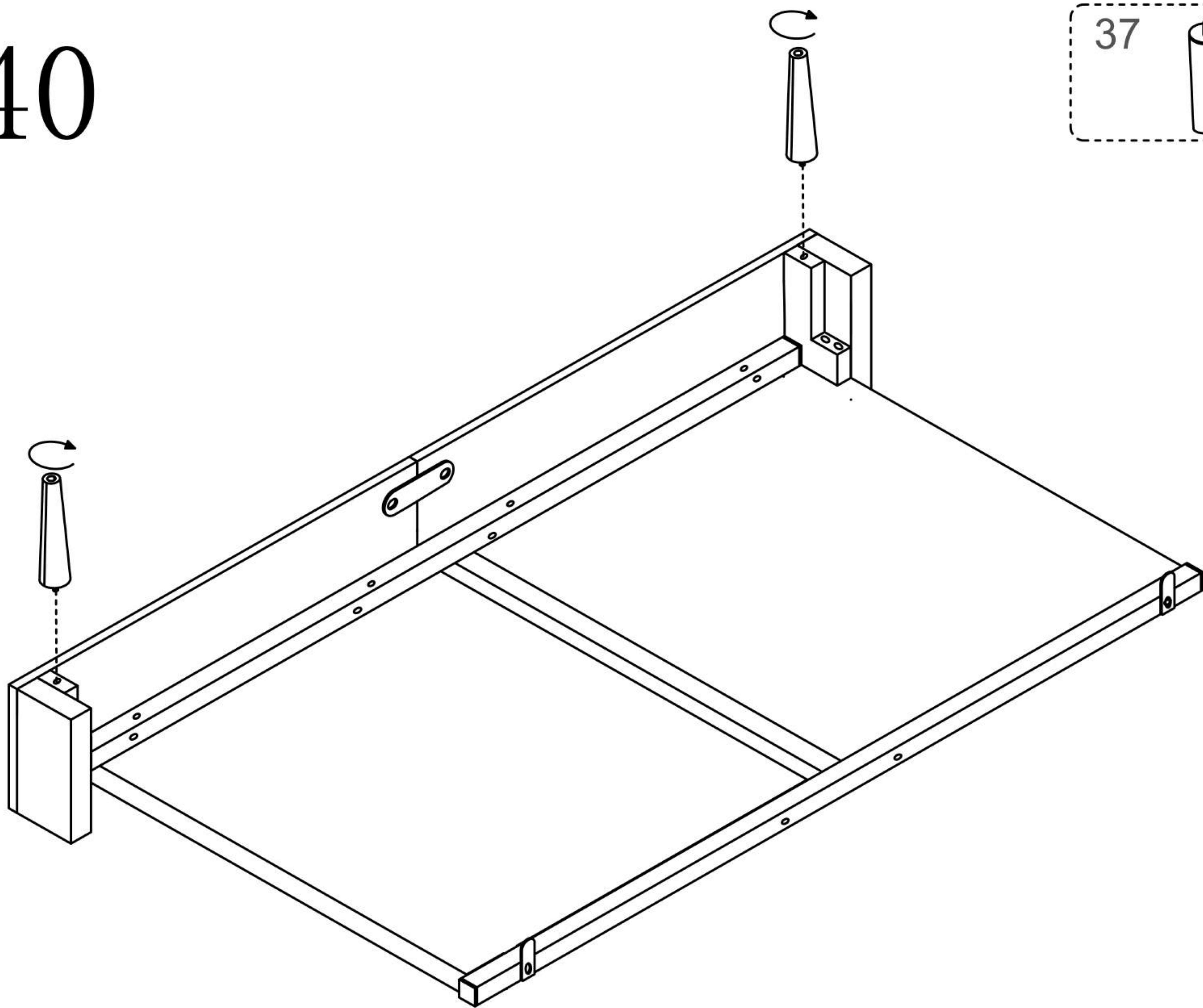

41-L

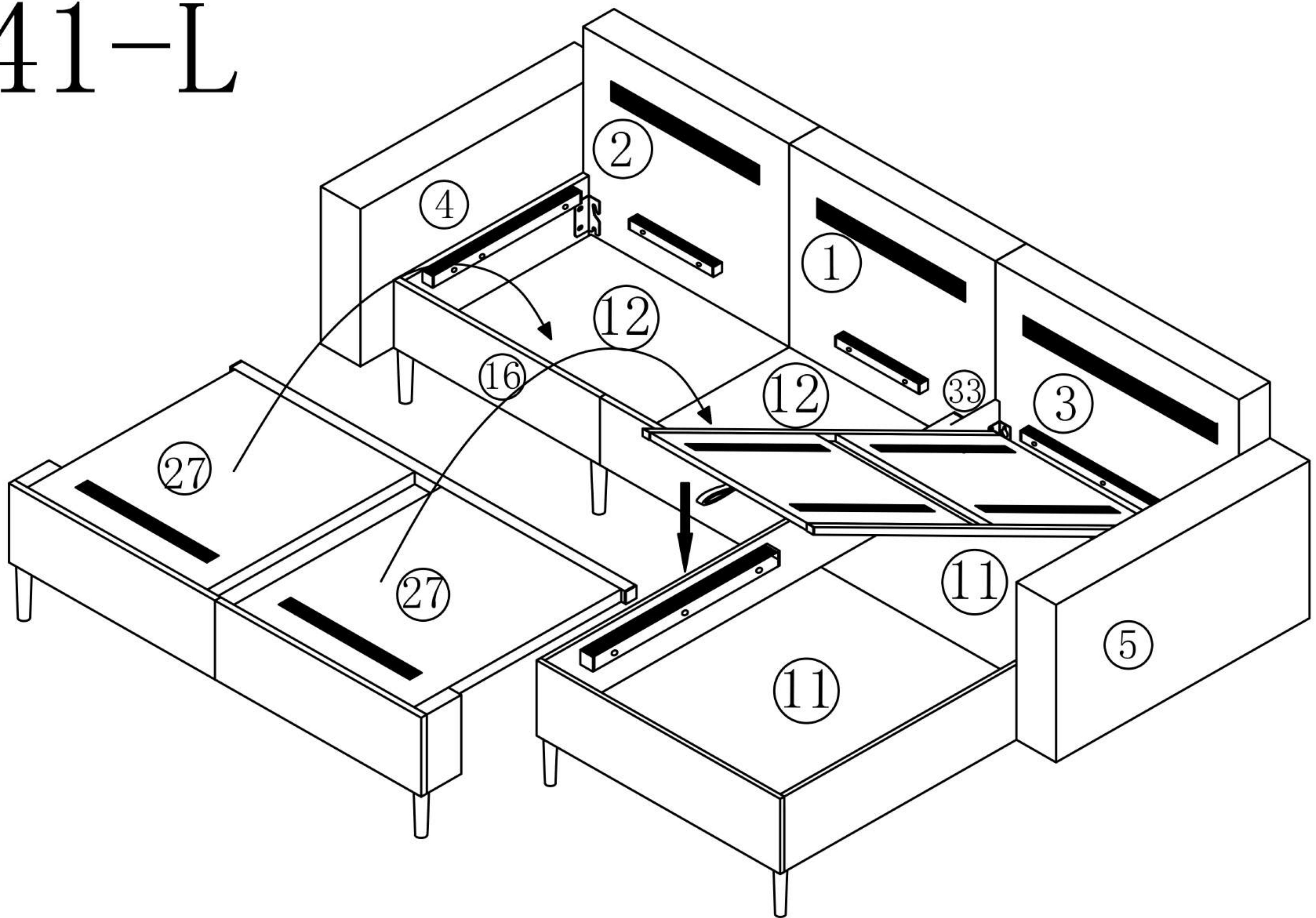

41-R

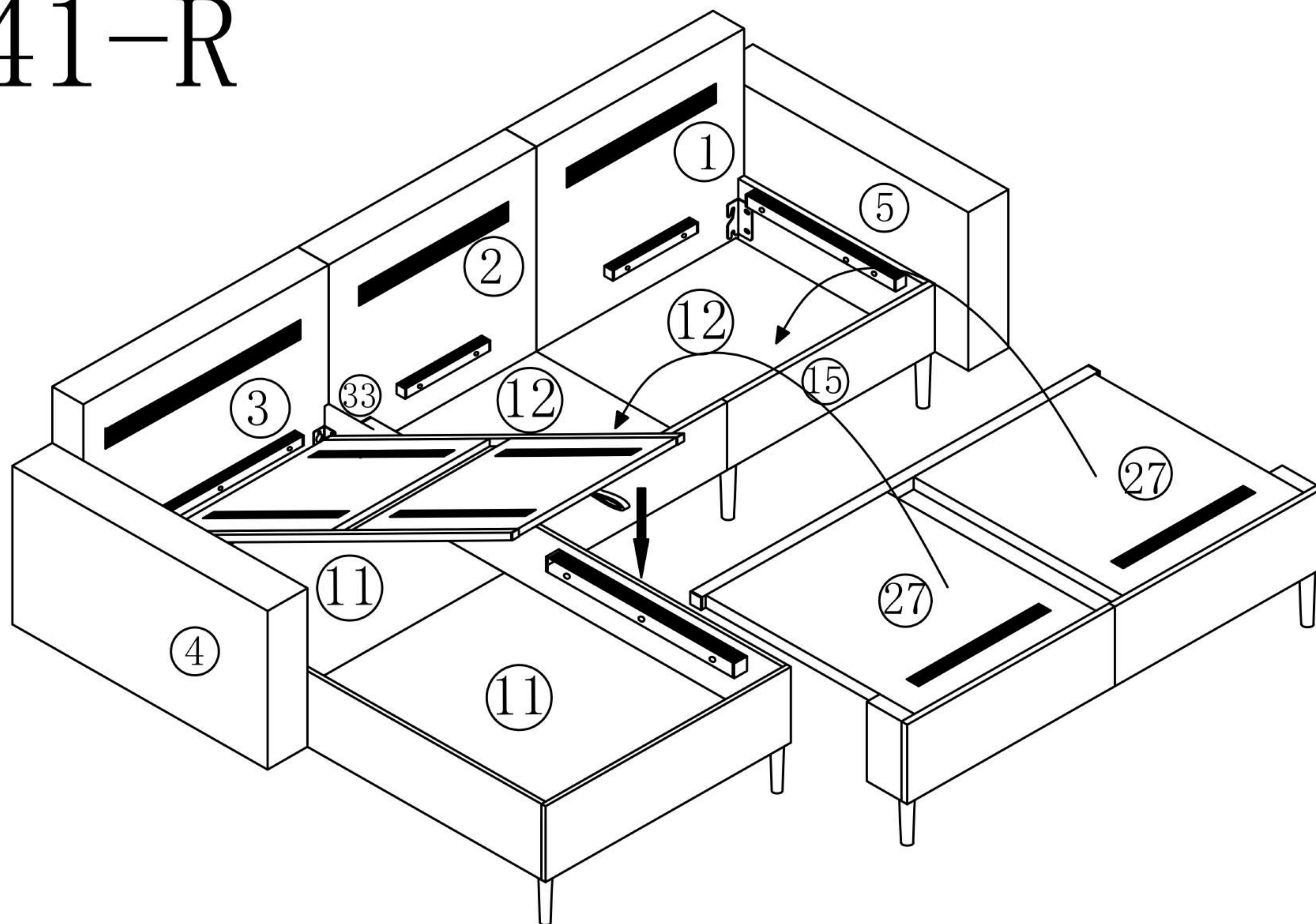

42

DE: Riss alle Stoffstreifen von den Teilen 1,2,3, 27, 28 und 29 ab.

EN: Tear off all the fabric strips on components No. 1,2,3, 27, 28 and 29.

FR: Retirez tous les bandes de tissu des pièces 1,2,3, 27, 28 et 29.

IT: Scolpi tutti i listelli di tessuto sui componenti n.1,2,3, 27, 28 e 29.

ES: Despegue todas las tiras de tela de los componentes números 1,2,3, 27, 28y 29.

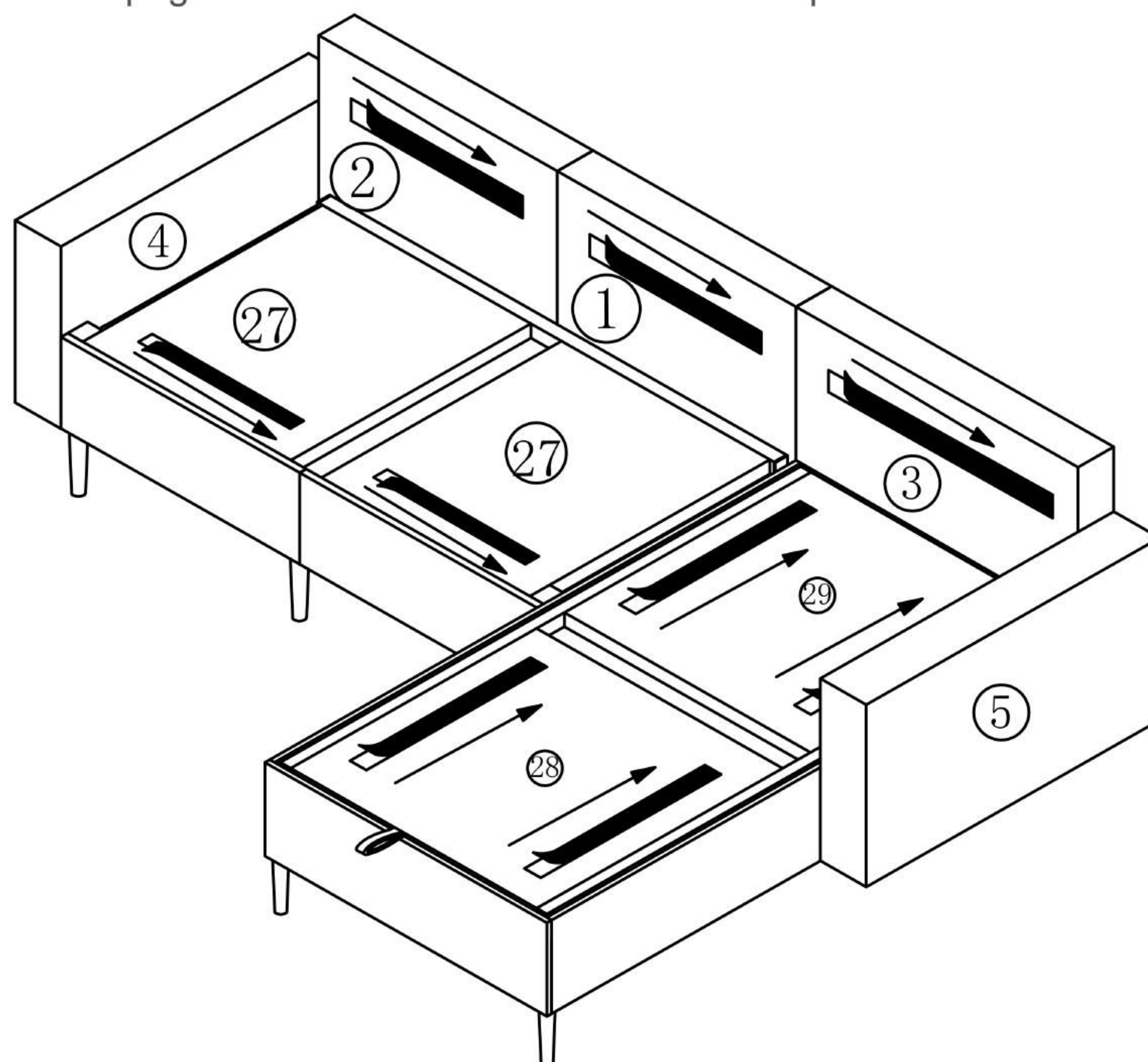

43

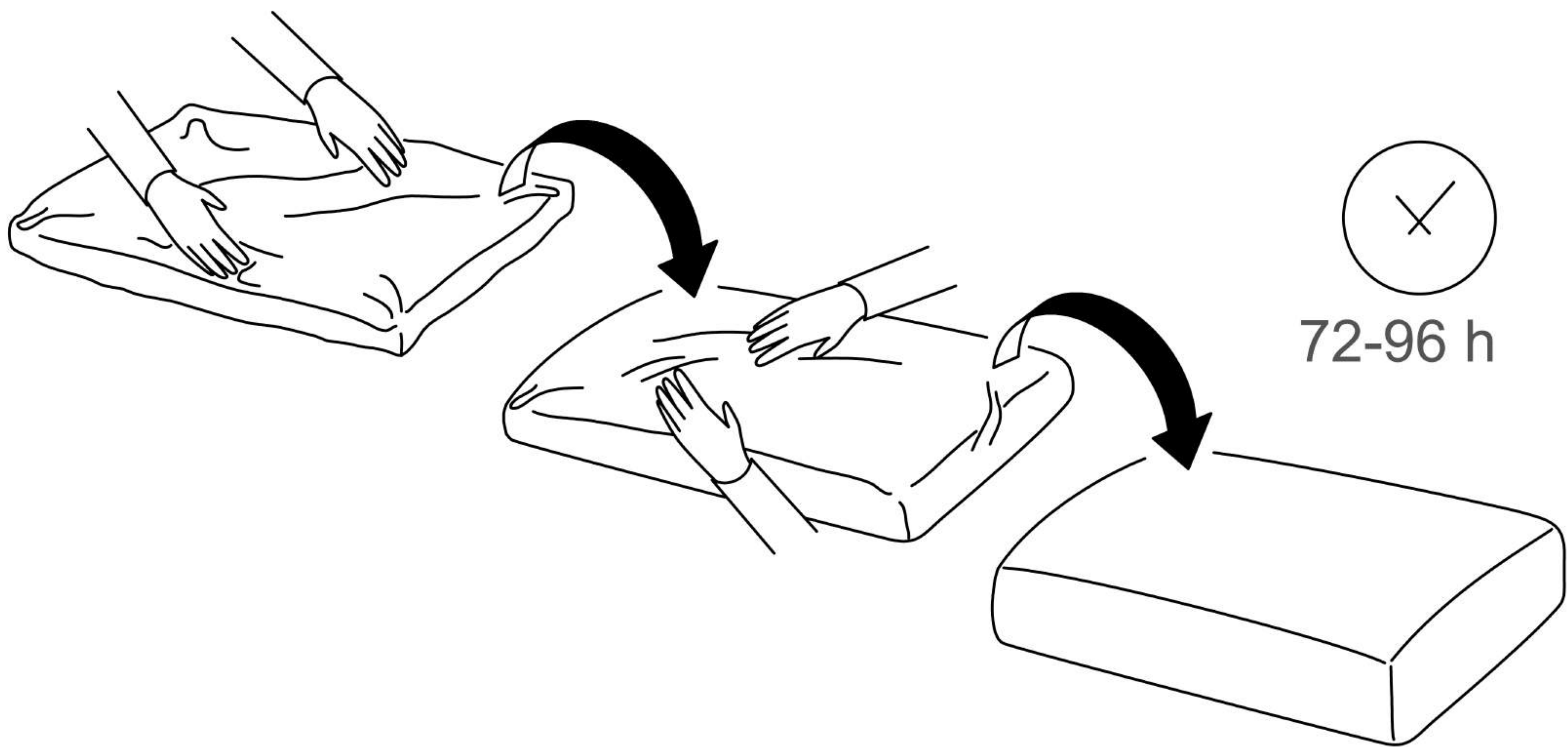
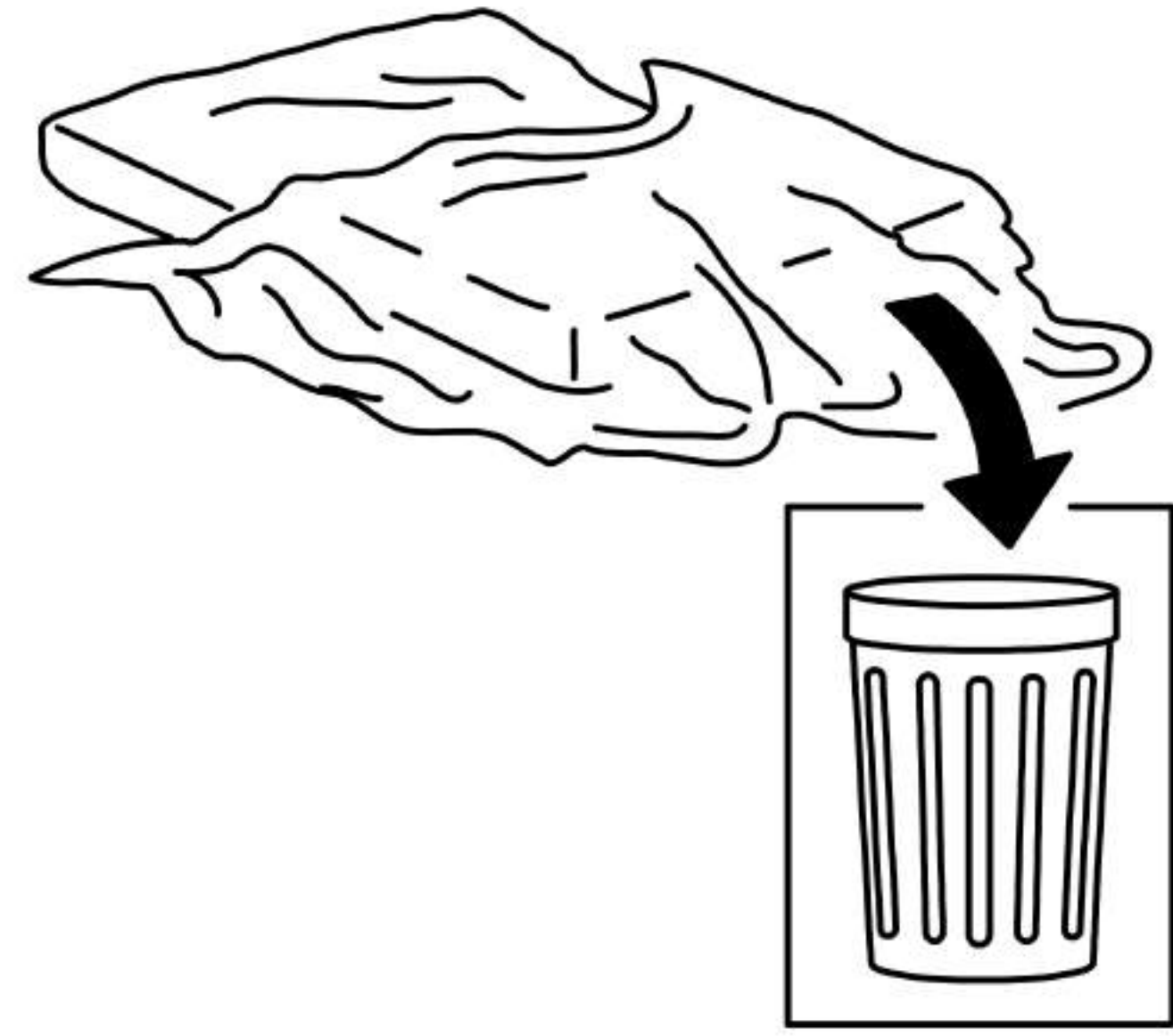
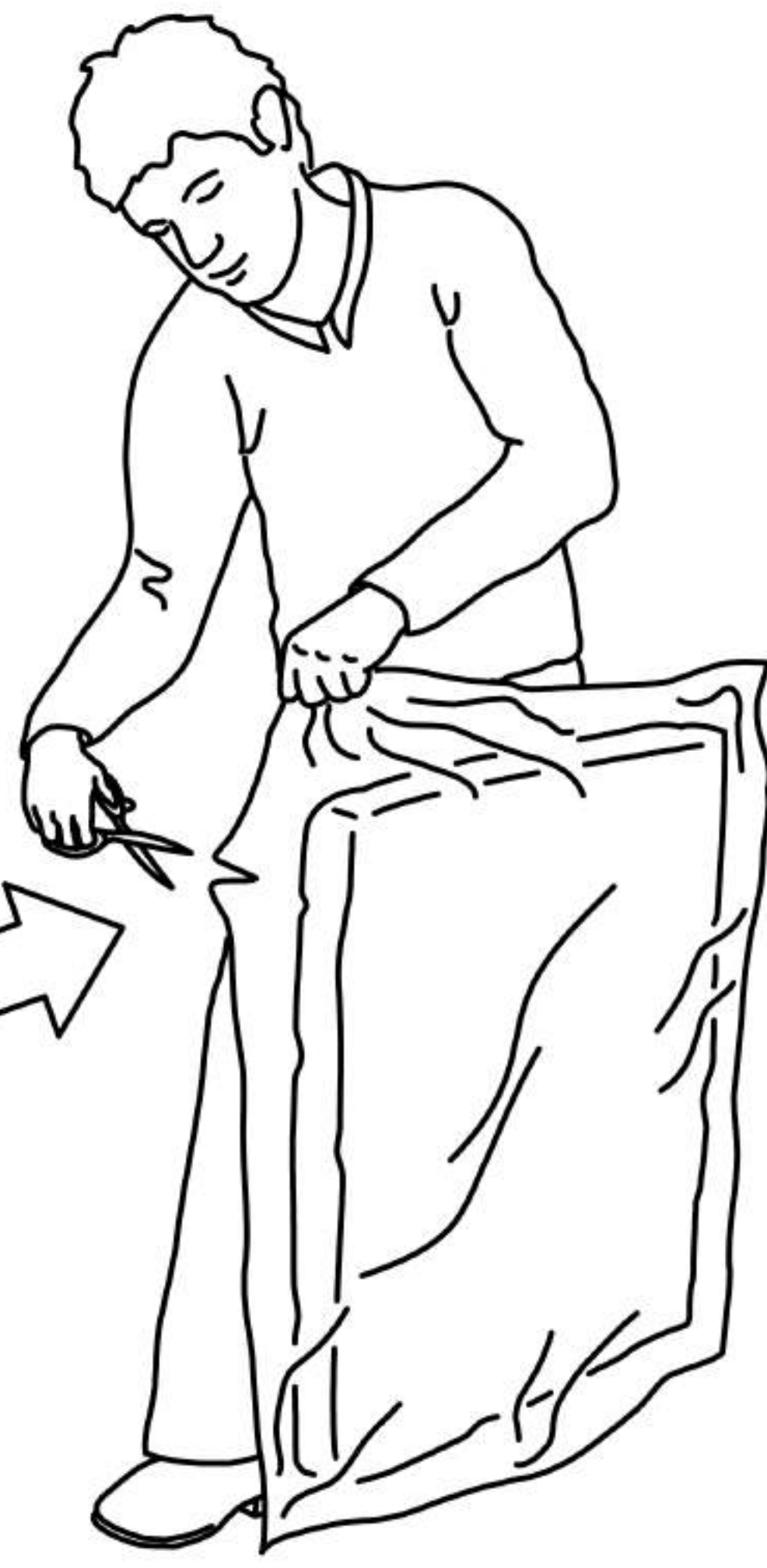
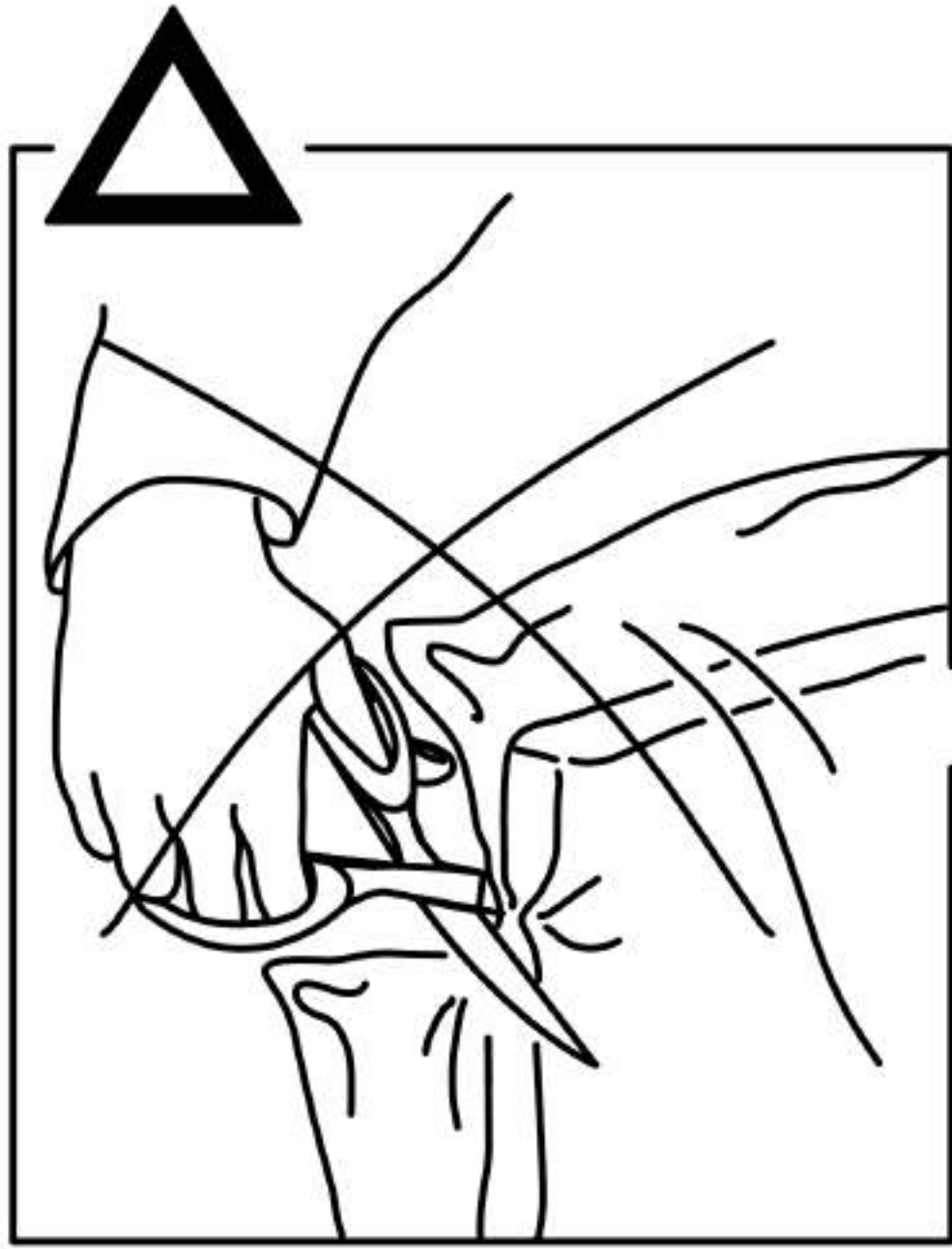
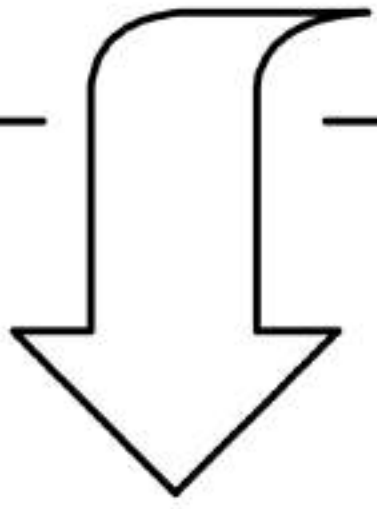
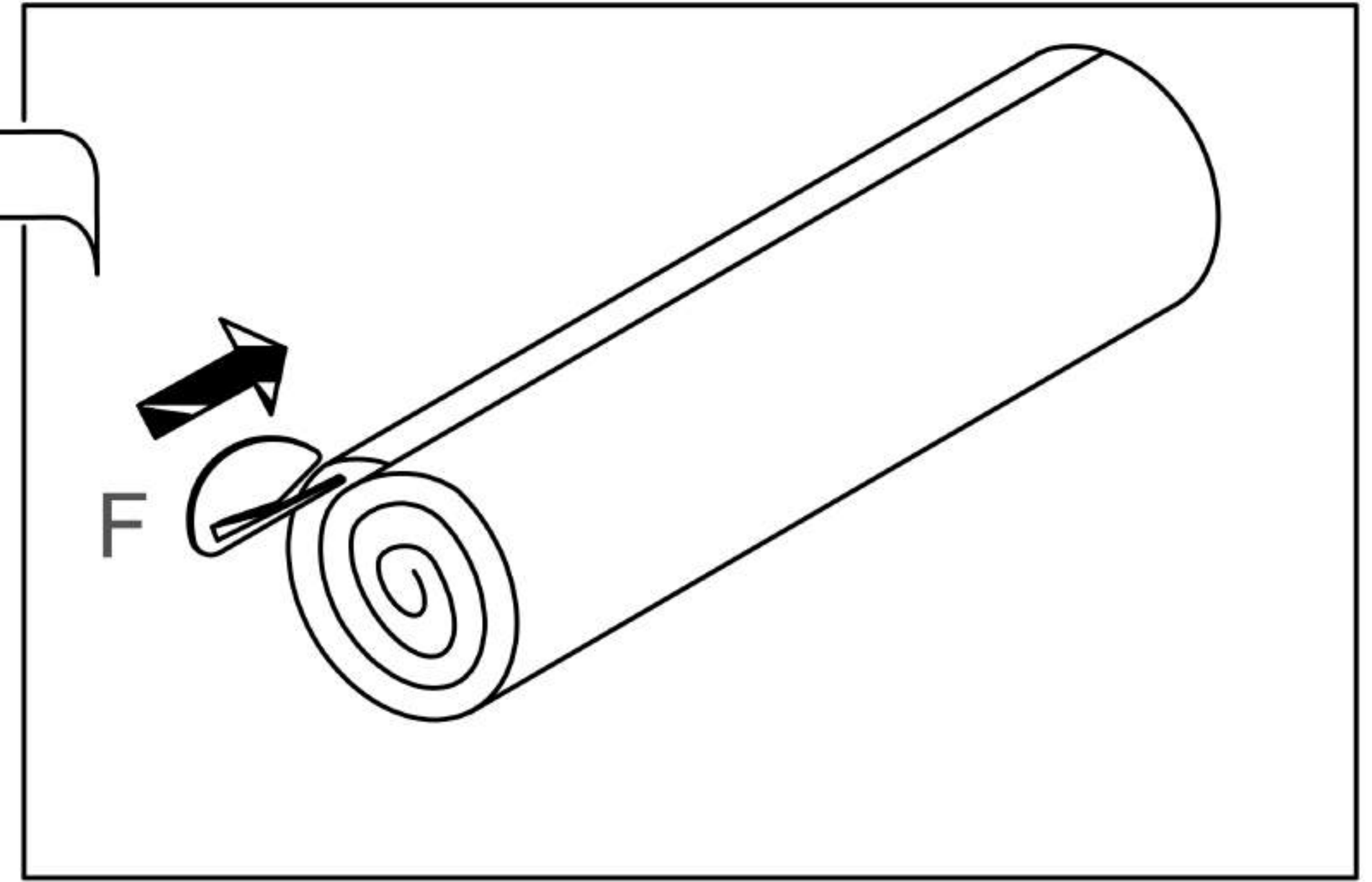
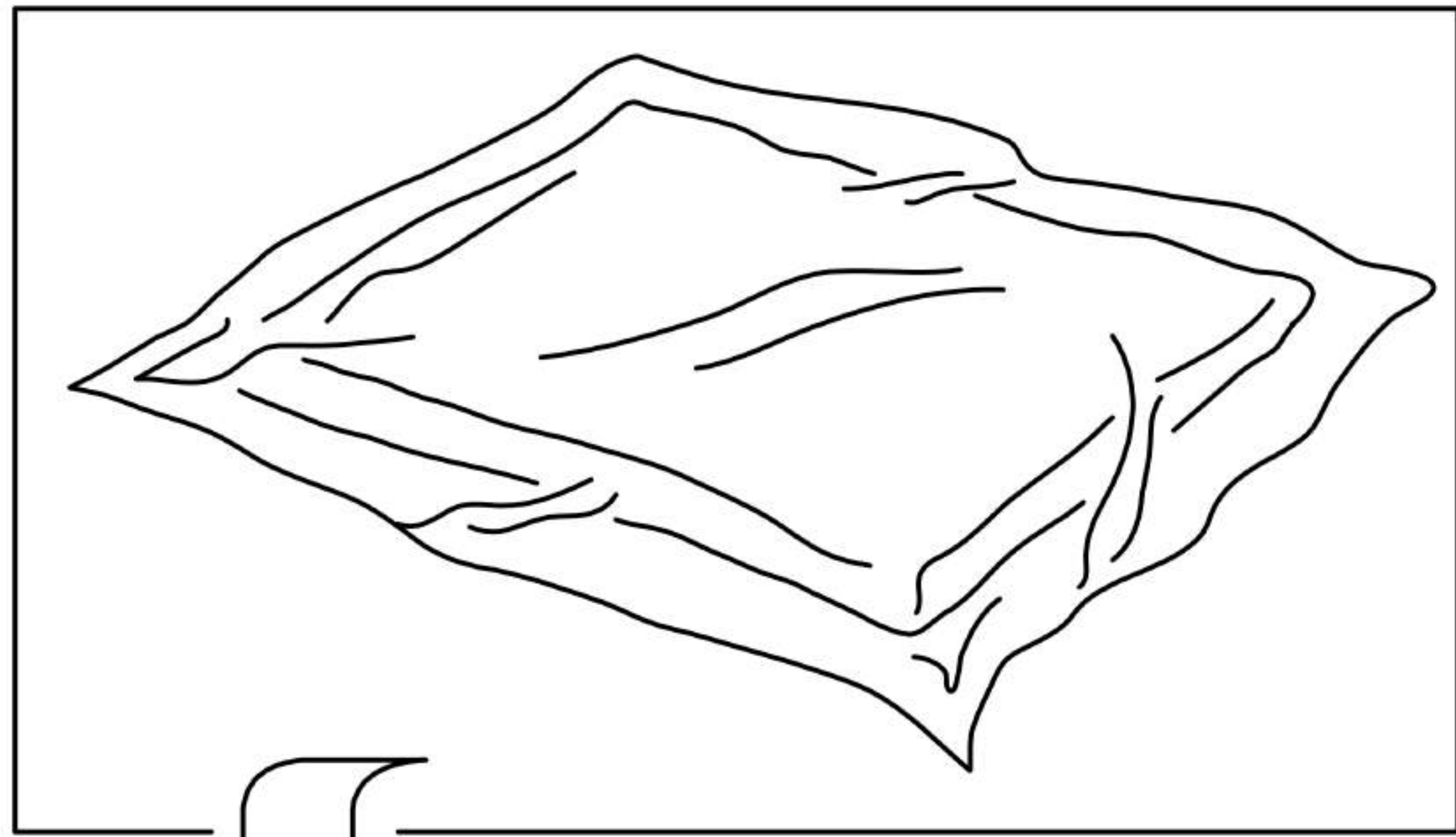

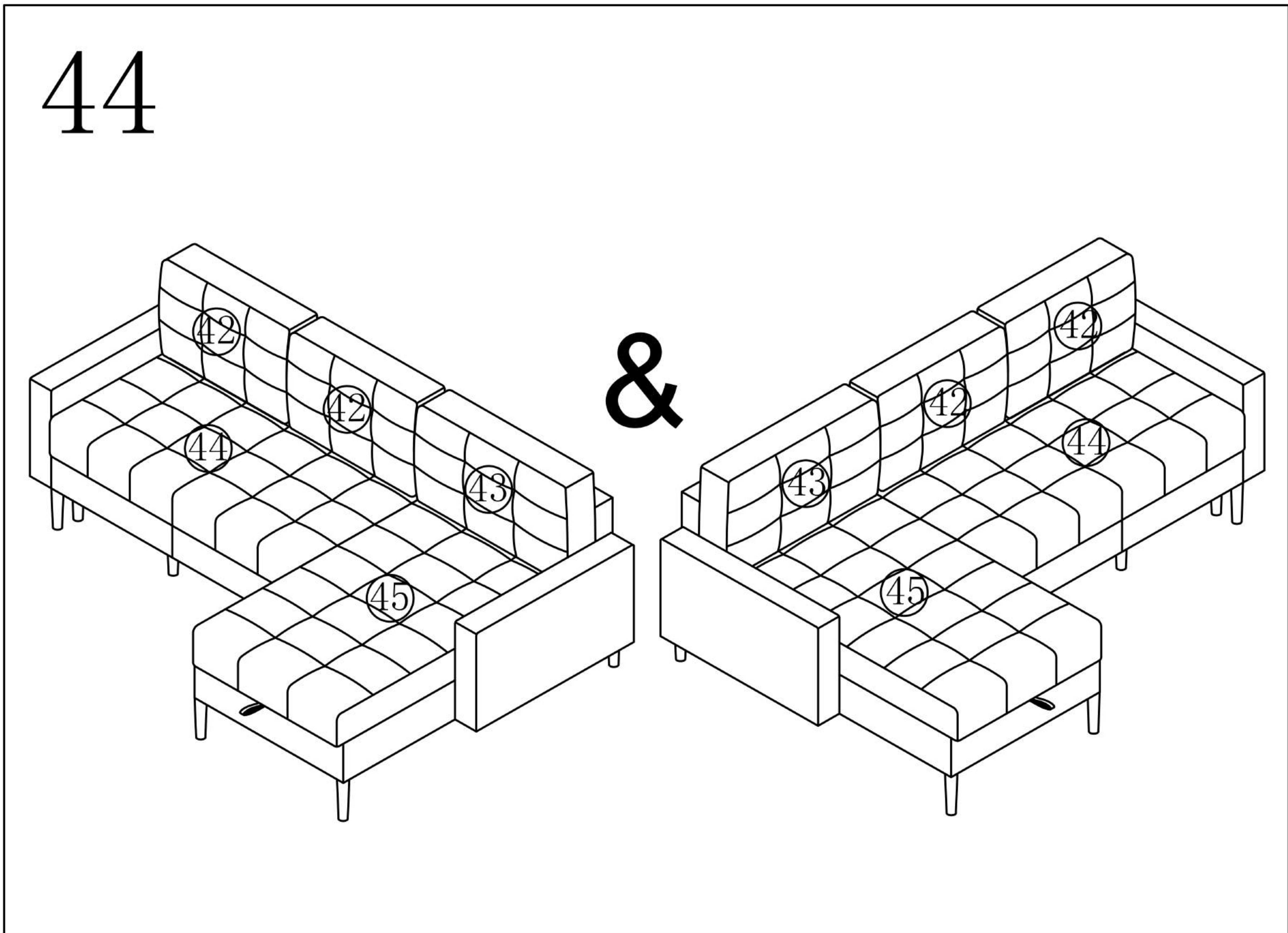
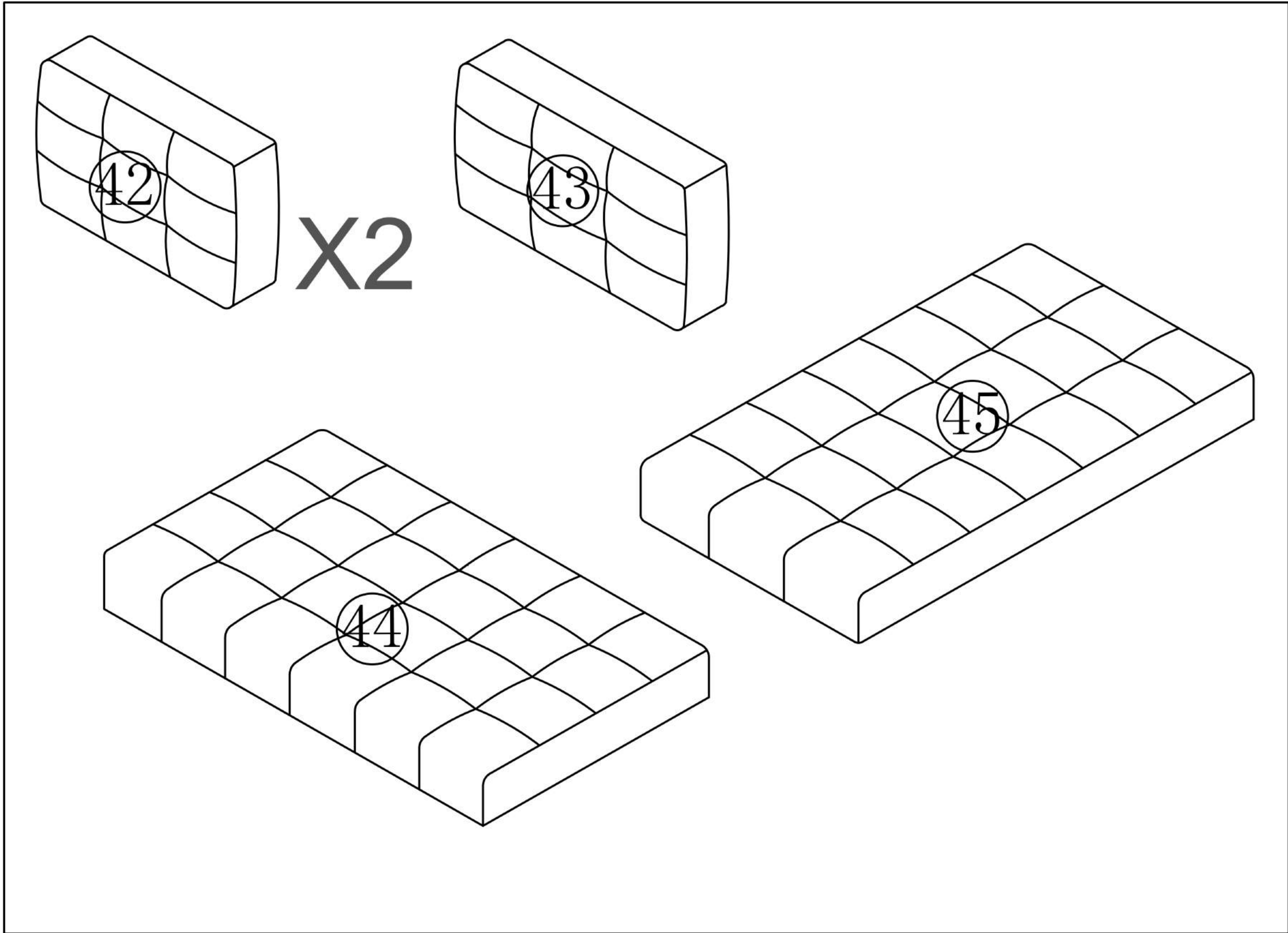

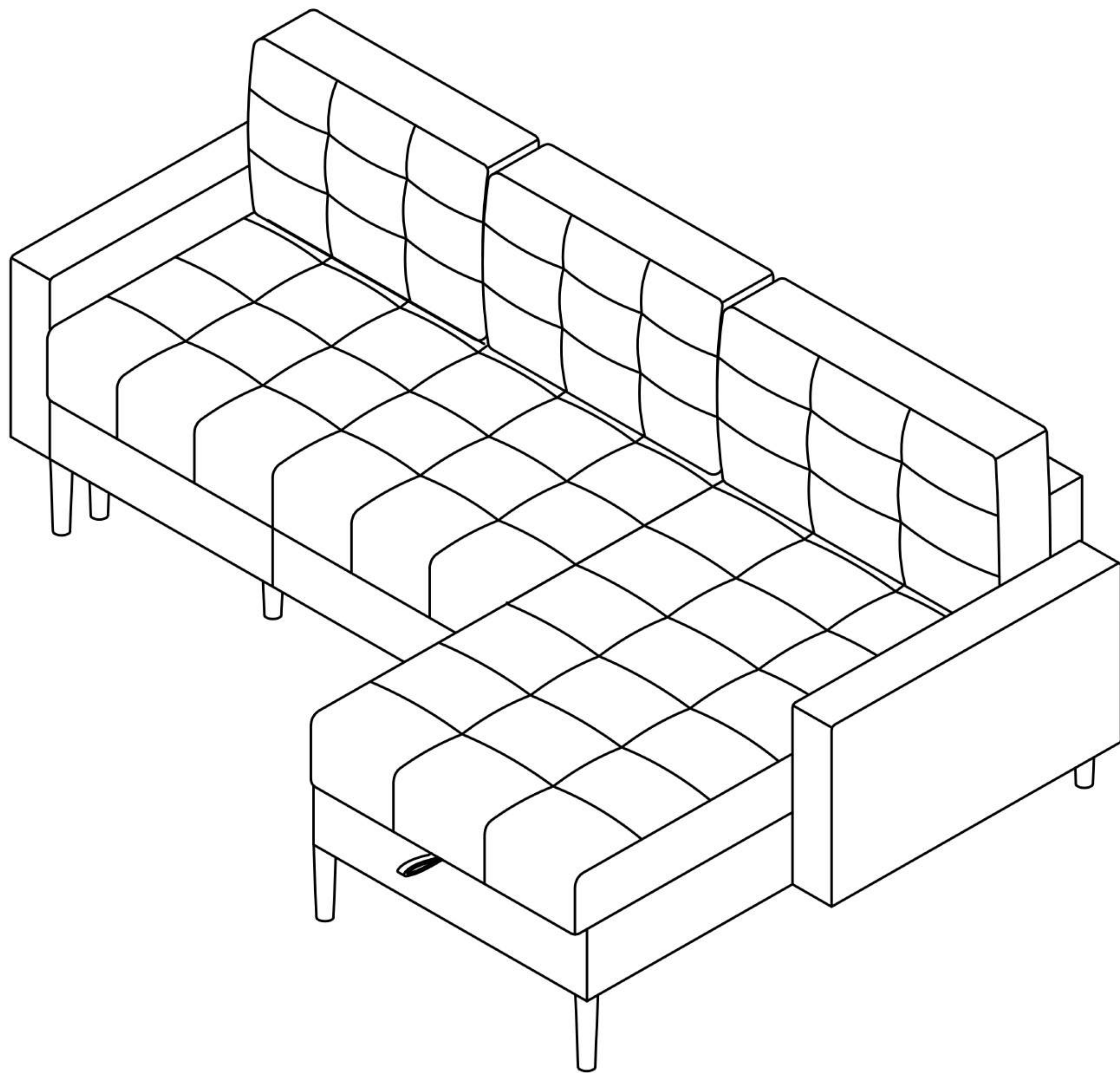

&

