

SKU N651P383873&N651P383875

DE:Installationsanleitung

UK:Installation Instruction

FR:Instruction d'installation

IT:Istruzioni di installazione

ES: Instrucciones de instalación

NL: Installatie-instructies

SE: Installationsanvisningar

PL: Instrukcje instalacji

Unser Produkt wird Ihnen in 2 Paketen geliefert. Die Lieferzeiten dieser 2 Pakete können abweichen, bitte haben Sie etwas Geduld und vielen Dank für Ihr Verständnis.

Our product will be delivered to you in 2 packages. The delivery times of these 2 packages may differ, please be patient and thank you for your understanding.

Notre produit vous sera livré en 2 colis. Les délais de livraison de ces 2 colis peuvent différer, soyez patient et merci pour votre compréhension.

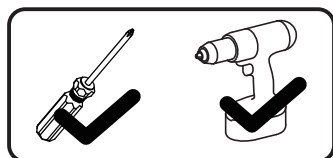
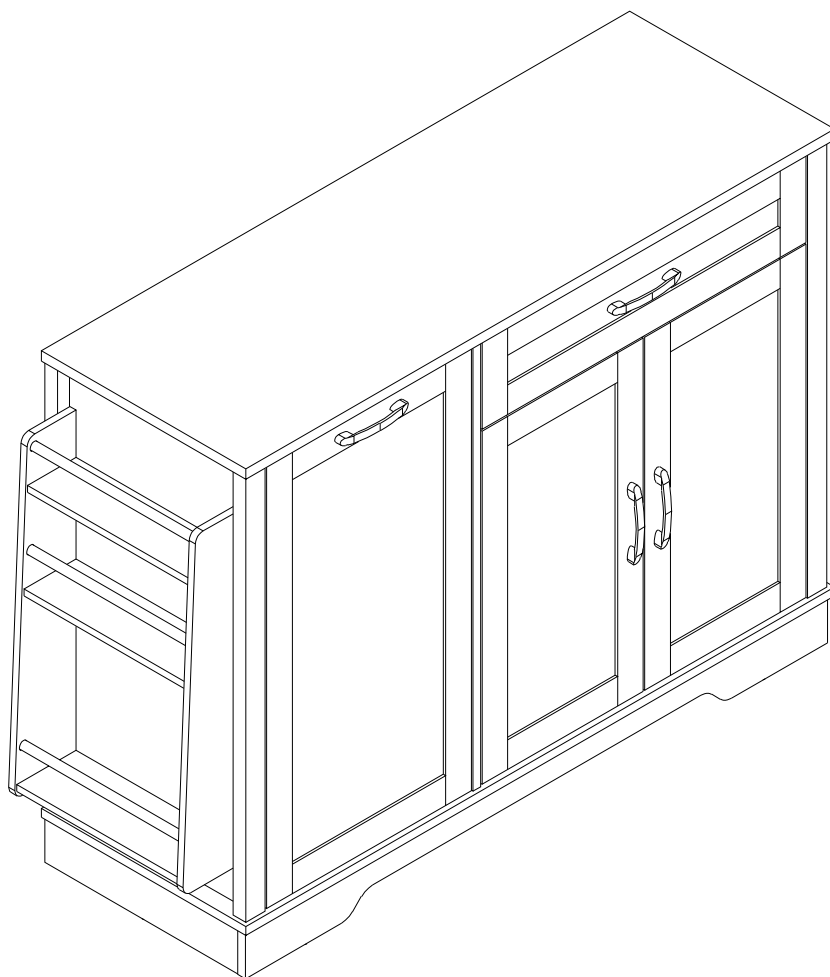

EN_IMPORTANT, RETAIN FOR FUTURE REFERENCE: READ CAREFULLY.

FR_IMPORTANT: A LIRE ATTENTIVEMENT ET À CONSERVER POUR CONSULTATION ULTÉRIEURE.

ES_IMPORTANTE, LEA Y GUARDE PARA FUTURAS REFERENCIAS.

DE_, WICHTIG! SORGFÄLTIG LESEN UND FÜR SPÄTER NACHSCHLAGEN AUFBEWAHREN."

IT_IMPORTANTE! CONSERVARE IL PRESENTE MANUALE PER FUTURO RIFERIMENTO E LEGGERLO ATTENTAMENTE.



DE

Warnung: Die maximale Belastbarkeit dieses Möbels beträgt: 60 kg, bitte nicht überlasten!

EN

Warning: The maximum load-bearing capacity of this furniture is: 60 kg, please do not overload!

FR

Avertissement : La capacité de charge maximale de ce meuble est de : 60 kg, merci de ne pas surcharger !

IT

Attenzione: la capacità di carico massima di questo mobile è: 60 kg, non sovraccaricare!

ES

Advertencia: La capacidad máxima de carga de este mueble es:60 kg, ¡no lo sobrecargue!



[DE]

Warnung: Lesen Sie die Anleitung vor dem Zusammenbau bitte vollständig durch. Überprüfen Sie, ob Sie alle auf den Seiten aufgeführten Komponenten und Werkzeuge haben.

Warnung: Legen Sie alle Teile auf eine ebene Fläche. Legen Sie eine weiche Decke oder Ähnliches darunter, um sie vor Kratzern oder Flecken zu schützen. Vermeiden Sie es, Komponenten über den Boden zu ziehen oder zu schieben.

Warnung: Überprüfen Sie regelmäßig alle Beschläge und Befestigungen, um sicherzustellen, dass sie sicher sind und um Unfälle zu vermeiden. Wenn Teile fehlen, kaputt, beschädigt oder abgenutzt sind, verwenden Sie das Produkt nicht weiter, bis es mit vom Hersteller autorisierten Teilen repariert wurde.

Warnung: Lassen Sie Kinder nicht auf die Möbel klettern, da dies zum Umkippen und zu schweren Verletzungen führen kann. Bauen Sie die Möbel außerhalb der Reichweite von Kindern zusammen.

Warnung: Stellen Sie die Möbel nicht in die Nähe von Feuerquellen oder heißen Gegenständen, um Brandgefahr zu vermeiden.

Warnung: Reinigen Sie die Möbel mit einem feuchten Tuch oder Alkohol. Verwenden Sie keine Reinigungsmittel mit ätzenden Chemikalien.

[EN]

Warning: Please read instructions fully before starting assembly. Check you have all the components and tools listed on pages.

Warning: Please place all parts on a flat surface. Place a soft blanket or similar underneath to protect against scratches or stains. Avoid dragging or sliding components across the floor.

Warning: Regularly check all fittings and fastenings to ensure they are secure and to prevent accidents. If any parts are missing, broken, damaged, or worn, discontinue use of the product until repairs have been made using factory authorized parts.

Warning: Do not allow children to climb on the furniture as this may result in tipping and serious personal injury. Assemble the furniture away from the reach of children.

Warning: Do not place furniture close to fire sources or high-temperature objects to avoid the risk of fire.

Warning: Clean furniture with a damp cloth or alcohol, avoid using cleaning agents containing corrosive chemicals.

[FR]

Avertissement : Veuillez lire entièrement les instructions avant de commencer l'assemblage. Vérifiez que vous disposez de tous les composants et outils répertoriés sur les pages.

Avertissement : Veuillez placer toutes les pièces sur une surface plane. Placez une couverture douce ou similaire en dessous pour les protéger des rayures ou des taches. Évitez de faire glisser les composants sur le sol.

Avertissement : Vérifiez régulièrement tous les raccords et fixations pour vous assurer qu'ils sont bien fixés et pour éviter les accidents. Si des pièces manquent, sont cassées, endommagées ou usées, cessez d'utiliser le produit jusqu'à ce que des réparations aient été effectuées à l'aide de pièces autorisées par l'usine.

Avertissement : Ne laissez pas les enfants grimper sur les meubles car cela pourrait entraîner un basculement et des blessures graves. Assemblez les meubles hors de portée des enfants.

Avertissement : Ne placez pas les meubles à proximité de sources de feu ou d'objets à haute température pour éviter tout risque d'incendie.

Avertissement : Nettoyez les meubles avec un chiffon humide ou de l'alcool, évitez d'utiliser des produits de nettoyage contenant des produits chimiques corrosifs.



[IT]

Attenzione: leggere attentamente le istruzioni prima di iniziare il montaggio. Verificare di avere tutti i componenti e gli strumenti elencati nelle pagine.

Attenzione: posizionare tutte le parti su una superficie piana. Posizionare una coperta morbida o simile sotto per proteggere da graffi o macchie. Evitare di trascinare o far scivolare i componenti sul pavimento.

Attenzione: controllare regolarmente tutti i raccordi e i dispositivi di fissaggio per assicurarsi che siano sicuri e per prevenire incidenti. Se alcune parti sono mancanti, rotte, danneggiate o usurate, interrompere l'uso del prodotto fino a quando non siano state eseguite le riparazioni utilizzando parti autorizzate dalla fabbrica.

Attenzione: non consentire ai bambini di arrampicarsi sui mobili poiché ciò potrebbe causare ribaltamenti e gravi lesioni personali. Montare i mobili lontano dalla portata dei bambini.

Attenzione: non posizionare i mobili vicino a fonti di fuoco o oggetti ad alta temperatura per evitare il rischio di incendio.

Attenzione: pulire i mobili con un panno umido o alcol, evitare di utilizzare detergenti contenenti sostanze chimiche corrosive.

[ES]

Advertencia: Lea las instrucciones completamente antes de comenzar el montaje. Compruebe que tiene todos los componentes y herramientas que se enumeran en las páginas.

Advertencia: Coloque todas las piezas sobre una superficie plana. Coloque una manta suave o algo similar debajo para protegerlas de rayones o manchas. Evite arrastrar o deslizar los componentes por el piso.

Advertencia: Verifique regularmente todos los accesorios y fijaciones para asegurarse de que estén seguros y evitar accidentes. Si falta alguna pieza, está rota, dañada o desgastada, deje de usar el producto hasta que se hayan realizado las reparaciones con piezas autorizadas de fábrica.

Advertencia: No permita que los niños se suban a los muebles, ya que esto puede provocar que se vuelquen y lesiones personales graves. Monte los muebles fuera del alcance de los niños.

Advertencia: No coloque los muebles cerca de fuentes de fuego u objetos de alta temperatura para evitar el riesgo de incendio.

Advertencia: Limpie los muebles con un paño húmedo o alcohol, evite usar agentes de limpieza que contengan químicos corrosivos.

Importeur	Decobus Handel GmbH
Adresse	Innungsstraße 9, 21244 Buchholz, Deutschland
URL	https://www.decobusgroup.de
Hersteller	FUJIAN FENLIN HOUSEWARE CO.,LTD.
Adresse	NO.65 QIAOTOUYANG,XIAZHUANG VILLAGE,TAZHUANG TOWN, MINQING COUNTY,FUZHOU CITY,FUJIAN PROVINCE
Partienummer	C811UZJ20250919TA
Hergestellt in	China
	Decobus Handel GmbH Innungsstraße 9, 21244 Buchholz, Deutschland https://www.decobusgroup.de

EN

Dear customer,

Thank you for purchasing this product. So that your appliance serves you well, please read all the instructions in this user's manual. If you have any questions, please contact our customer care center.

FR

Cher client,

Nous vous remercions d'avoir acheté ce produit. Afin que vous puissiez profiter pleinement de votre appareil, veuillez lire toutes les instructions de ce manuel d'utilisation. Si vous avez la moindre question, veuillez contacter notre centre d'assistance à la clientèle.

DE

Sehr geehrter Kunde,

Vielen Dank, dass Sie dieses Produkt erworben haben. Damit Ihr Gerät Ihnen gute Dienste leistet, lesen Sie bitte alle Hinweise in diesem Benutzerhandbuch. Wenn Sie Fragen haben, wenden Sie sich bitte an unser Kundendienstzentrum.

ES

Queridos clientes,

Gracias por comprar este producto. Para que su electrodoméstico le sirva mejor, lea todas las instrucciones de este manual del usuario. Si tiene alguna pregunta, comuníquese con nuestro Centro de Atención al Cliente.

IT

Caro Cliente,

Grazie per aver acquistato questo prodotto. Per servirti meglio con questo apparecchio ti prego di leggere tutte le istruzioni in presente manuale utente. In caso di dubbio, si prega di contattare il nostro centro assistenza clienti.

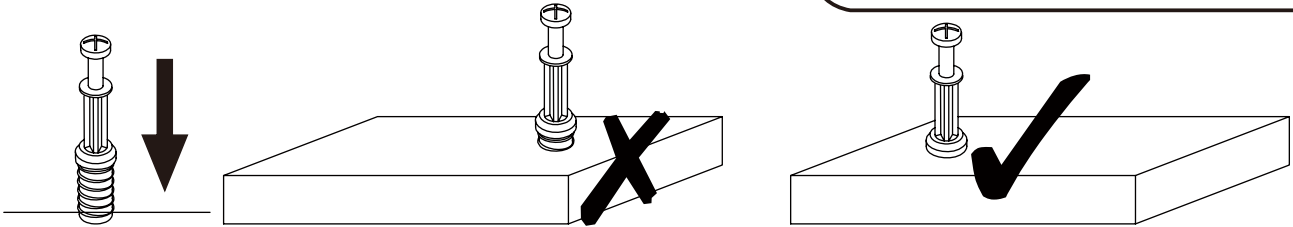

EN_QUICKFIT: Tighten quickfit until shoulder is flush with panel. Do not overtighten or undertighten.

FR_RACCORD RAPIDE: Faites serrer le raccord rapide jusqu'à ce que l'épaulement soit parfaitement encastré dans le panneau. Il ne faut ni trop serrer ni insuffisamment serrer.

ES_QUICKFIT: Apriete quickfit hasta que el hombro se descargue con el panel. NO lo sobreapriete ni lo apriete poco.

DE_QUICKFIT: Ziehen Sie den Quickfit fest, bis die Schulter mit der Platte bündig ist. Bitte nicht zu fest oder zu schwach anziehen.

IT_MONTAGGIO RAPIDO: Stringere il montaggio rapido fino a quando la spalla è a filo con il pannello, non stringere troppo o troppo poco.

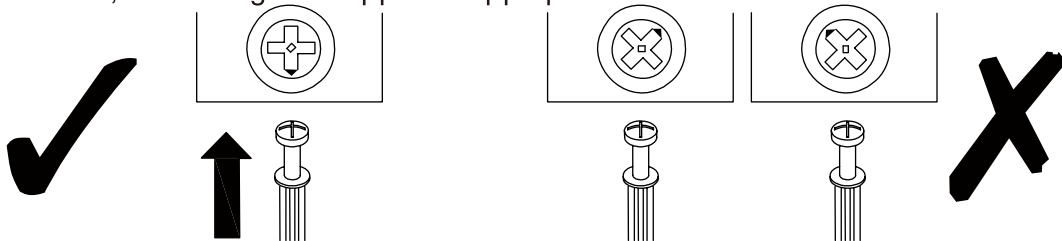

EN_CAM LOCK: When fitting cam lock, ensure starting position is correct before you insert connecting quickfit.

FR_SERRURE BATTEUSE: Avant d'insérer la serrure batteuse, veillez à la bonne orientation avant d'insérer le raccord rapide.

ES_CIERRE DE LA CÁMARA: Cuando instale el cierre de la cámara, asegúrese de que la posición de inicio es correcta antes de que inserte el quickfit conector.

DE_CAM-LOCK: Achten Sie bei der Montage des Cam-Locks auf die richtige Ausgangsposition, bevor Sie den Quickfit einsetzen.

IT_BLOCCAGGIO A CAMMA: Quando si monta il bloccaggio a camma, assicurarsi che la posizione iniziale sia corretta prima di inserire il montaggio rapido di collegamento.

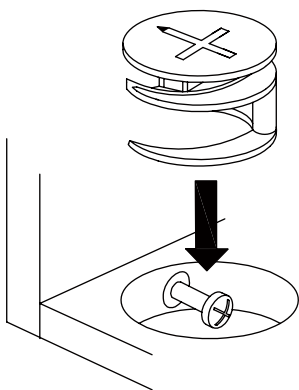

EN_Quickfit head should be in the centre of the cam lock when the two panels are joined.

Cam lock should be inserted before quickfit.

FR_Lorsque les deux panneaux sont assemblés, la tête du raccord rapide doit reposer au centre de la serrure batteuse. Il faut insérer la serrure batteuse avant le raccord rapide.

ES_El cabezal del quickfit debe estar en el centro del cierre de la cámara cuando se unan los dos paneles.

Se debe insertar el cierre de la cámara antes que el quickfit.

DE_Der Quickfit-Kopf sollte sich in der Mitte des Cam-Locks befinden, wenn die beiden Platten zusammengefügt sind.

Der Cam-Lock sollte vor dem Quickfit eingesetzt werden.

IT_La testa del montaggio rapido deve trovarsi al centro del bloccaggio a camma quando i due pannelli sono uniti.

Il Bloccaggio a Camma deve essere inserito prima del montaggio rapido.

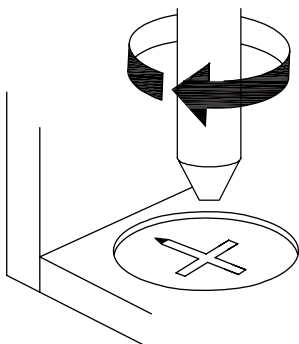

EN_Turn cam lock clockwise to tighten.

FR_Faites tourner la serrure batteuse dans le sens des aiguilles d'une montre pour la resserrer.

ES_Gire el cierre de la cámara en sentido horario para apretarlo.

DE_Drehen Sie den Cam-Lock im Uhrzeigersinn, um ihn festzuziehen.

IT_Ruotare il bloccaggio a camma in senso orario per stringere.

EN It may be necessary to adjust the hinges so that the doors align. Use the instructions below as a guide.

FR Il est parfois nécessaire d'ajuster les charnières pour un meilleur alignement des portes. Servez-vous des instructions ci-dessous comme guide.

ES Puede que sea necesario ajustar los quicios de forma que se alineen las puertas. Use las instrucciones que aparecen debajo como guía.

DE Möglicherweise müssen Sie die Scharniere so einstellen, dass die Türen ausgerichtet sind. Verwenden Sie die nachstehenden Anweisungen als Leitfaden.

IT Potrebbe essere necessario regolare le cerniere in modo che le porte siano allineate. Per fare ciò attenersi alle istruzioni sottostanti.

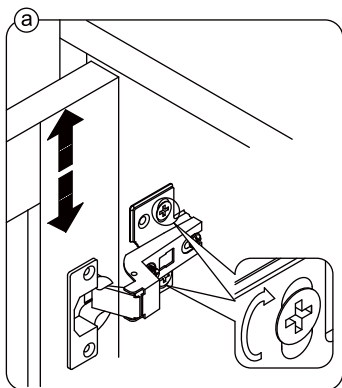

EN To adjust the door vertically loosen the screw as shown and move up and down as needed.

FR Si vous souhaitez régler la porte **verticalement**, desserrez la vis comme indiqué et déplacez la porte de haut en bas selon les besoins.

ES Para ajustar la puerta **verticalmente** afloje el tornillo tal y como se muestra y muévelo hacia arriba o hacia abajo según sea necesario.

DE Um die Tür **vertikal** auszurichten, lösen Sie die Schraube wie abgebildet und bewegen Sie sie nach Bedarf nach oben oder nach unten.

IT Per allineare la porta **verticalmente** allentare la vite come mostrato e spostarla in alto o in basso secondo necessità.

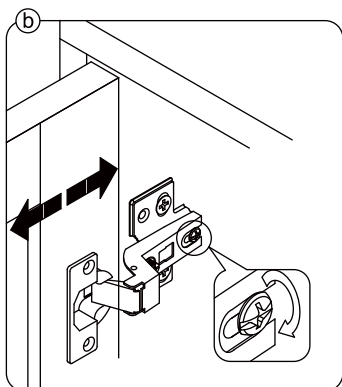

EN To adjust the gap from the door to the main frame turn the screw clockwise or anti-clockwise as needed.

FR Si vous souhaitez ajuster l'**écart** entre la porte et le cadre principal, tournez la vis dans le sens des aiguilles d'une montre ou dans le sens inverse, si nécessaire.

ES Para ajustar el **espacio** desde la puerta al marco principal, gire el tornillo en sentido horario o antihorario, según se necesite.

DE Um den **Abstand** von der Tür zum Hauptrahmen auszurichten, drehen Sie die Schraube je nach Bedarf im oder gegen den Uhrzeigersinn.

IT Per regolare lo **spazio** tra la porta e il telaio principale, avvitare o svitare la vite secondo necessità.

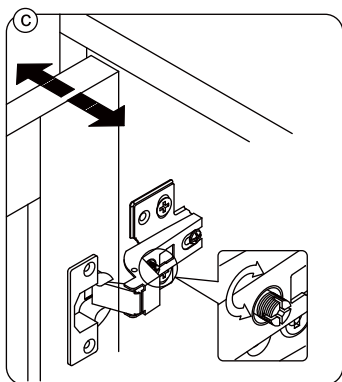

EN To adjust the door laterally adjust the screw as shown by turning clockwise or anti-clockwise.

FR Si vous souhaitez ajuster la porte **latéralement**, ajustez la vis comme indiqué en tournant dans le sens des aiguilles d'une montre ou dans le sens inverse des aiguilles d'une montre.

ES Para ajustar la puerta **lateralmente** ajuste el tornillo tal y como se muestra girándolo en sentido horario y antihorario.

DE Um die Tür **seitlich** auszurichten, stellen Sie bitte die Schraube wie abgebildet durch Drehen im oder gegen den Uhrzeigersinn ein.

IT Per allineare la porta **lateralmente** regolare la vite come mostrato, avvitandola o svitandola.

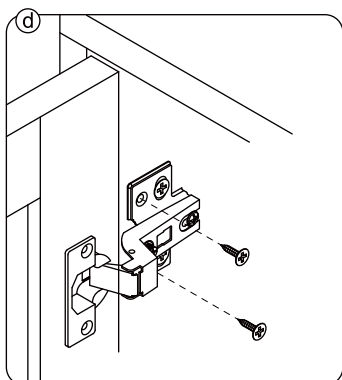

EN Please fix other screws

FR Merci de serrer les autres vis.

ES Fije los demás tornillos

DE Befestigen Sie bitte die anderen Schrauben

IT Fissare le altre viti

Assembly Instruction / Montageanleitung

ITEM:N651P383873+ N651P383875

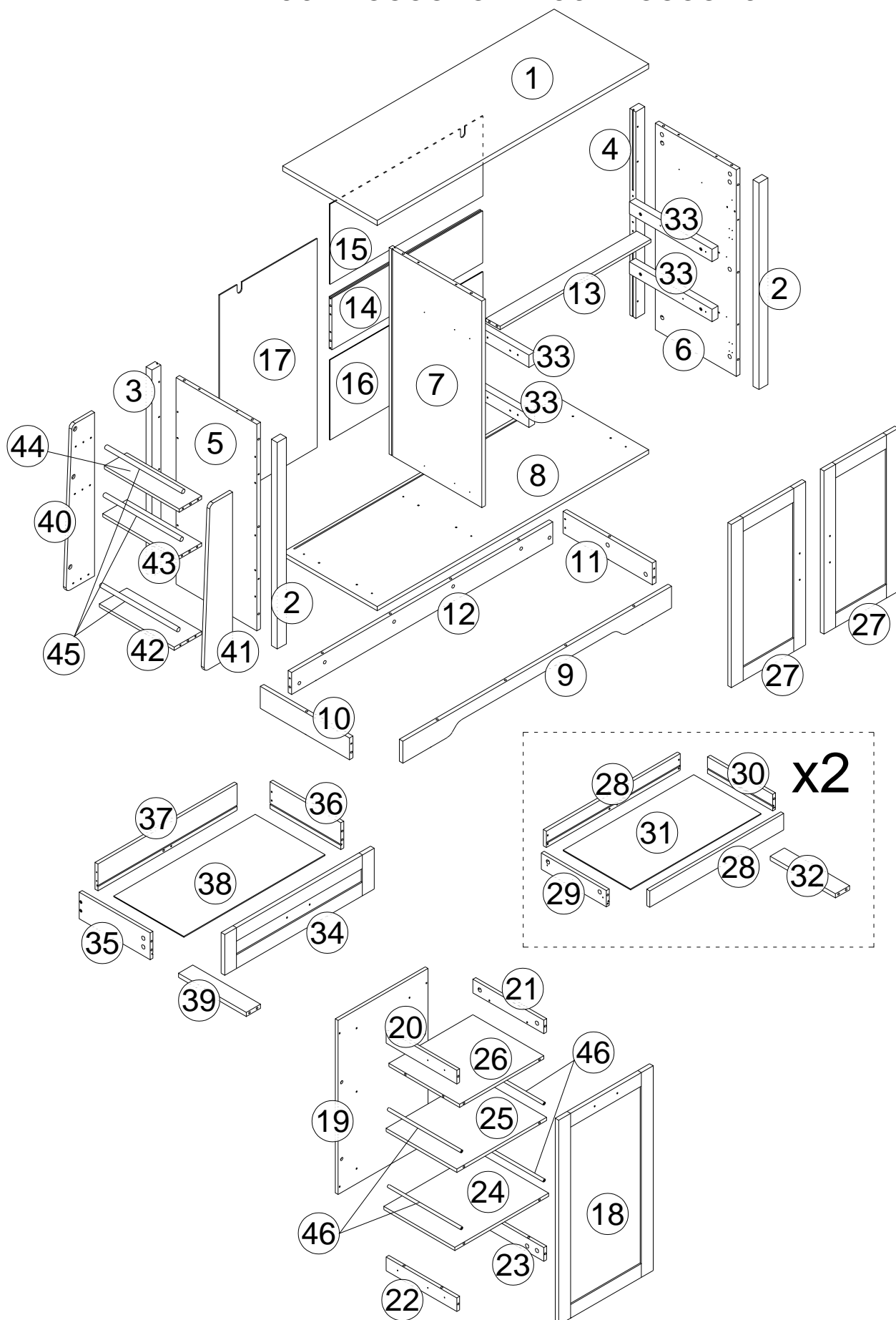

Teileliste / Part List / Liste des pièces / Elenco delle parti / Lista de piezas

Please check you have all the panels listed below

/Bitte überprüfen Sie, ob alle unten aufgeführten Panels vorhanden sind

Note: The quantities below are the correct amount to complete the assembly. In some cases more fittings may be supplied than are required. / Hinweis: Die unten angegebenen Mengen sind die richtigen Mengen, um die Montage abzuschließen. In manchen Fällen können mehr Armaturen geliefert werden, als erforderlich sind.

N651P383873

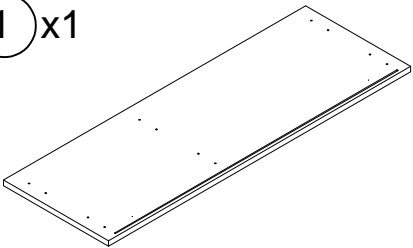
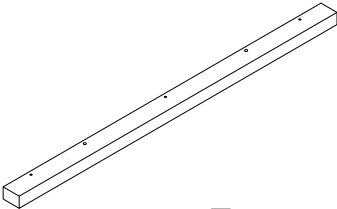
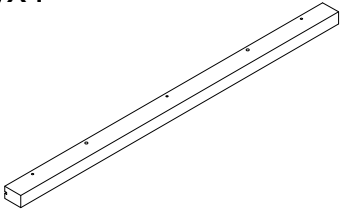
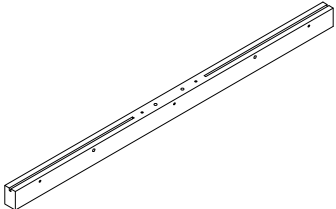
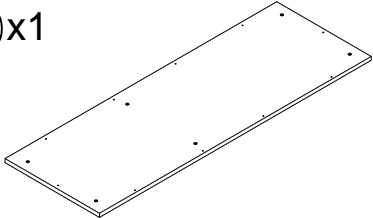
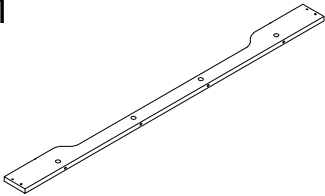
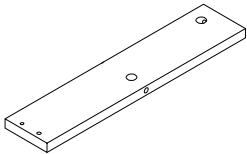
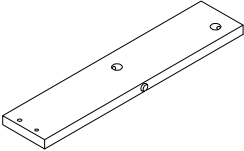
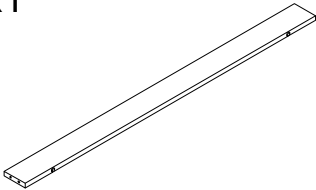
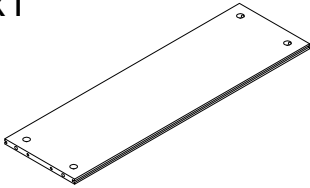
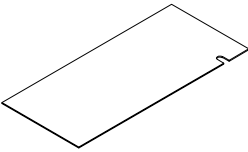
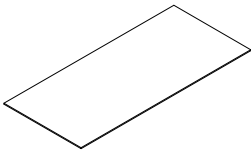
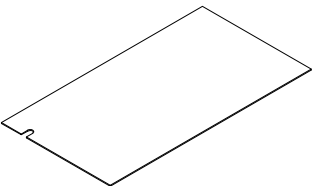
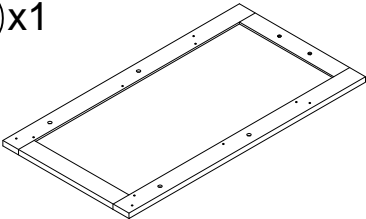
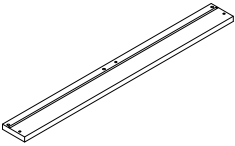
<p>① x1</p>  <p>Top panel</p>	<p>② x2</p>  <p>Front post</p>	<p>③ x1</p>  <p>Rear left post</p>
<p>④ x1</p>  <p>Rear right post</p>	<p>⑧ x1</p>  <p>Bottom panel</p>	<p>⑨ x1</p>  <p>Front apron</p>
<p>⑩ x1</p>  <p>Left apron</p>	<p>⑪ x1</p>  <p>Right apron</p>	<p>⑫ x1</p>  <p>Rear apron</p>
<p>⑭ x1</p>  <p>Back crossbar</p>	<p>⑮ x1</p>  <p>Right upper back panel</p>	<p>⑯ x1</p>  <p>Right lower back panel</p>
<p>⑰ x1</p>  <p>Left back panel</p>	<p>⑱ x1</p>  <p>Drawer rack front panel</p>	<p>⑳ x4</p>  <p>Inner drawer front</p>

Teileliste / Part List / Liste des pièces / Elenco delle parti / Lista de piezas

Please check you have all the panels listed below

/Bitte überprüfen Sie, ob alle unten aufgeführten Panels vorhanden sind

Note: The quantities below are the correct amount to complete the assembly. In some cases more fittings may be supplied than are required. / Hinweis: Die unten angegebenen Mengen sind die richtigen Mengen, um die Montage abzuschließen. In manchen Fällen können mehr Armaturen geliefert werden, als erforderlich sind.

N651P383873

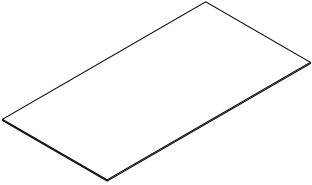
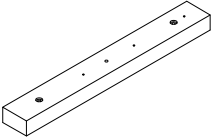
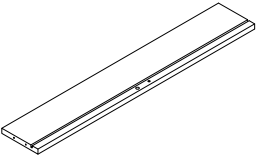
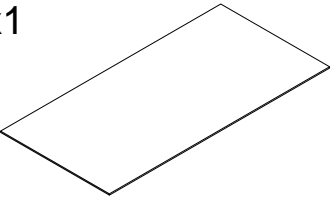
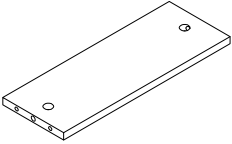
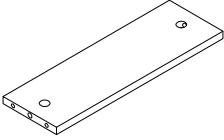
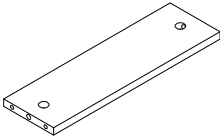
<p>③①x2</p>  <p>Inner drawer bottom</p>	<p>③③x4</p>  <p>Inner drawer supporter</p>	<p>③⑦x1</p>  <p>Big drawer rear panel</p>
<p>③⑧x1</p>  <p>Big drawer bottom</p>	<p>④②x1</p>  <p>Left rack lower shelf</p>	<p>④③x1</p>  <p>Left rack middle shelf</p>
<p>④④x1</p>  <p>left rack upper shelf</p>		

Teileliste / Part List / Liste des pièces / Elenco delle parti / Lista de piezas

Please check you have all the panels listed below

/Bitte überprüfen Sie, ob alle unten aufgeführten Panels vorhanden sind

Note: The quantities below are the correct amount to complete the assembly. In some cases more fittings may be supplied than are required. / Hinweis: Die unten angegebenen Mengen sind die richtigen Mengen, um die Montage abzuschließen. In manchen Fällen können mehr Armaturen geliefert werden, als erforderlich sind.

N651P383875

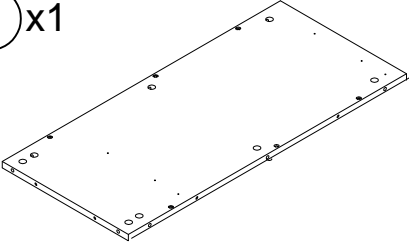
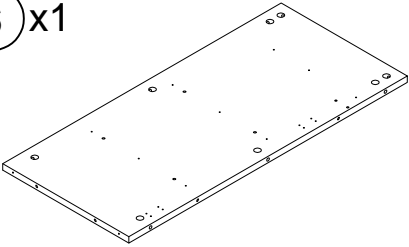
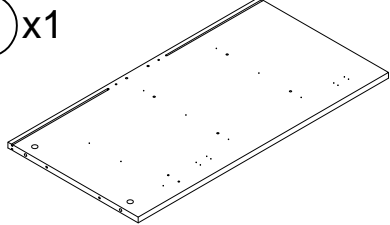
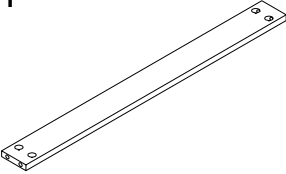
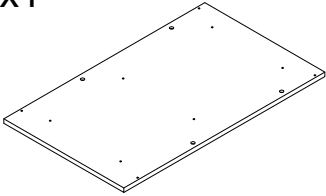
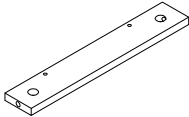
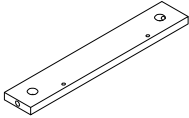
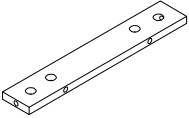
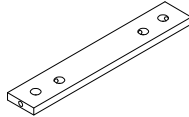
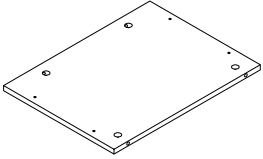
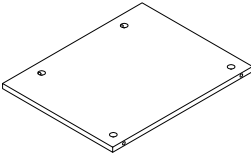
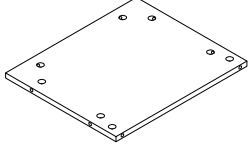
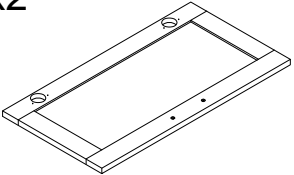
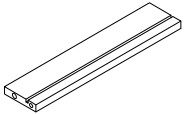
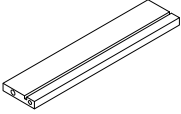
<p>⑤ x1</p>  <p>Left side panel</p>	<p>⑥ x1</p>  <p>Right side panel</p>	<p>⑦ x1</p>  <p>Partition</p>
<p>⑬ x1</p>  <p>Front crossbar</p>	<p>⑰ x1</p>  <p>Drawer rack back panel</p>	<p>⑳ x1</p>  <p>Drawer rack left upper side</p>
<p>⑳ x1</p>  <p>Drawer rack right upper side</p>	<p>㉒ x1</p>  <p>Drawer rack left lower side</p>	<p>㉓ x1</p>  <p>Drawer rack right lower side</p>
<p>㉔ x1</p>  <p>Drawer rack lower shelf</p>	<p>㉕ x1</p>  <p>Drawer rack middle shelf</p>	<p>㉖ x1</p>  <p>Drawer rack upper shelf</p>
<p>㉗ x2</p>  <p>Door</p>	<p>㉙ x2</p>  <p>Inner drawer left side</p>	<p>㉚ x2</p>  <p>Inner drawer right side</p>

Teileliste / Part List / Liste des pièces / Elenco delle parti / Lista de piezas

Please check you have all the panels listed below

/Bitte überprüfen Sie, ob alle unten aufgeführten Panels vorhanden sind

Note: The quantities below are the correct amount to complete the assembly. In some cases more fittings may be supplied than are required. / Hinweis: Die unten angegebenen Mengen sind die richtigen Mengen, um die Montage abzuschließen. In manchen Fällen können mehr Armaturen geliefert werden, als erforderlich sind.

N651P383875

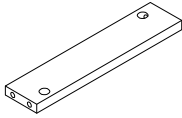
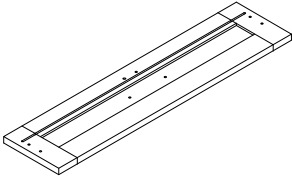
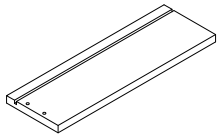
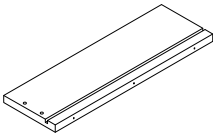
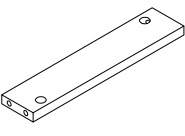
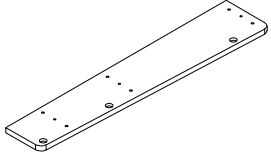
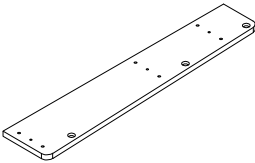
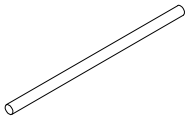
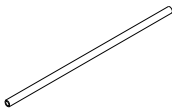
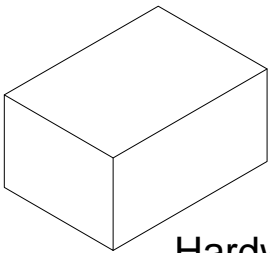











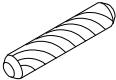
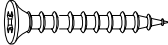

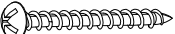

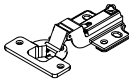
<p>32)x2</p>  <p>Inner drawer supporter</p>	<p>34)x1</p>  <p>Big drawer front</p>	<p>35)x1</p>  <p>Big drawer left side</p>
<p>36)x1</p>  <p>Big drawer right side</p>	<p>39)x1</p>  <p>Big drawer supporter</p>	<p>40)x1</p>  <p>Left rack left side</p>
<p>41)x1</p>  <p>Left rack right side</p>	<p>45)x3</p>  <p>Left rack rail</p>	<p>46)x4</p>  <p>Drawer rack rail</p>
 <p>Hardware kit</p>		

Hardwareliste / Hardware List / Liste de matériel / Elenco hardware / Lista de hardware ITEM:N651P383873&N651P383875

Please check you have all the panels listed below

/Bitte überprüfen Sie, ob alle unten aufgeführten Panels vorhanden sind

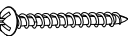
Note: The quantities below are the correct amount to complete the assembly. In some cases more fittings may be supplied than are required. / Hinweis: Die unten angegebenen Mengen sind die richtigen Mengen, um die Montage abzuschließen. In manchen Fällen können mehr Armaturen geliefert werden, als erforderlich sind.

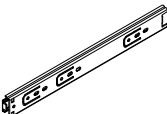
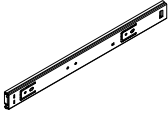
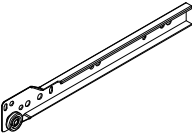
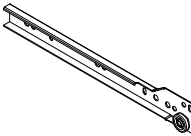
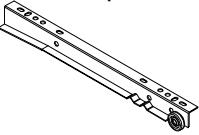
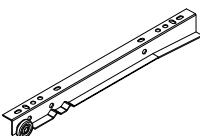
A x 92pcs  eccentric rod	B x 92pcs  eccentric rod gear	C x 66pcs  M6x30mm Dowels	D x 16pcs  M4x35 Screws	E x 54pcs  M3.5x14 Screws	F x 12pcs  M4x30 Screws
G x 30pcs  M3.5x12mm Screws	H x 4pcs  Hinge	I x 4pcs  Handle	J x 6pcs  M4x18 Bolts	K x 2pcs  M4x10 Bolts	L x 12pcs  M3x14 Screws
M x 12pcs  panel hook	N x 2pcs N1  N3  N4  N2  Screws	O x 4pcs  Slide	P x 4pcs  Slide	CL x1pc  300mm Slide	CR x1pc  300mm Slide
DL x1pc  300mm Slide	DR x1pc  300mm Slide				

EN:Before installation, insert the screws into the holes and tighten them, but do not tighten them to 100%, 70% to 80% is sufficient. Finally, after all screws are installed, tighten all screws to 100%.If you encounter these issues, such as if the holes cannot be aligned or some parts cannot be installed, please check if the screws are used correctly and adjust the tightness of the screws.

FR:Insérer la vis dans le trou avant la fin de l'assemblage, serrer la vis, mais ne pas serrer à 100%, 70% ~ 80% est correct. Enfin, une fois que toutes les vis sont bien serrées, toutes les vis sont serrées à 100%.Si vous rencontrez ces problèmes, par exemple si les trous ne sont pas alignés ou si certaines pièces ne peuvent pas être montées, vérifiez que les vis sont utilisées correctement et Ajustez leur serrage.

ES:Antes de la instalación, inserte los tornillos en los orificios y apriéte los, pero no los apriete al 100 %, basta con apretarlos entre un 70 % y un 80 %. Por último, una vez instalados todos los tornillos, apriéte los al 100 %. Si se encuentra con estos problemas, como que los orificios no se pueden alinear o que algunas piezas no se pueden instalar, compruebe si los tornillos se utilizan correctamente y ajuste la tensión de los tornillos.Traducción realizada con la versión gratuita del traductor DeepL.com que les vis sont utilisées correctement et Ajustez leur serrage.

DE:Vor dem Einbau die Schrauben in die Löcher stecken und festziehen, aber nicht bis 100%, 70% bis 80% anziehen reicht aus. Schließlich, nachdem alle Schrauben installiert sind, ziehen Sie alle Schrauben auf 100%.Wenn Sie auf diese Probleme stoßen, wie z. B. Fehlausrichtung der Löcher oder Unfähigkeit, bestimmte Teile zu installieren, überprüfen Sie bitte, ob die Schrauben korrekt verwendet werden und passen Sie die Dichtigkeit der Schrauben an.

IT:Prima dell'installazione, inserire le viti nei fori e serrarle, ma non serrarle al 100%, è sufficiente serrarle al 70-80%. Infine, dopo aver installato tutte le viti, serrare tutte le viti al 100%. Se si verificano questi problemi, ad esempio se i fori non possono essere allineati o alcune parti non possono essere installate, verificare che le viti siano utilizzate correttamente e regolare il serraggio delle viti.

Step 1

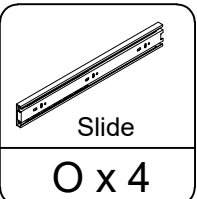
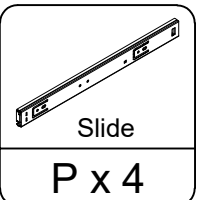
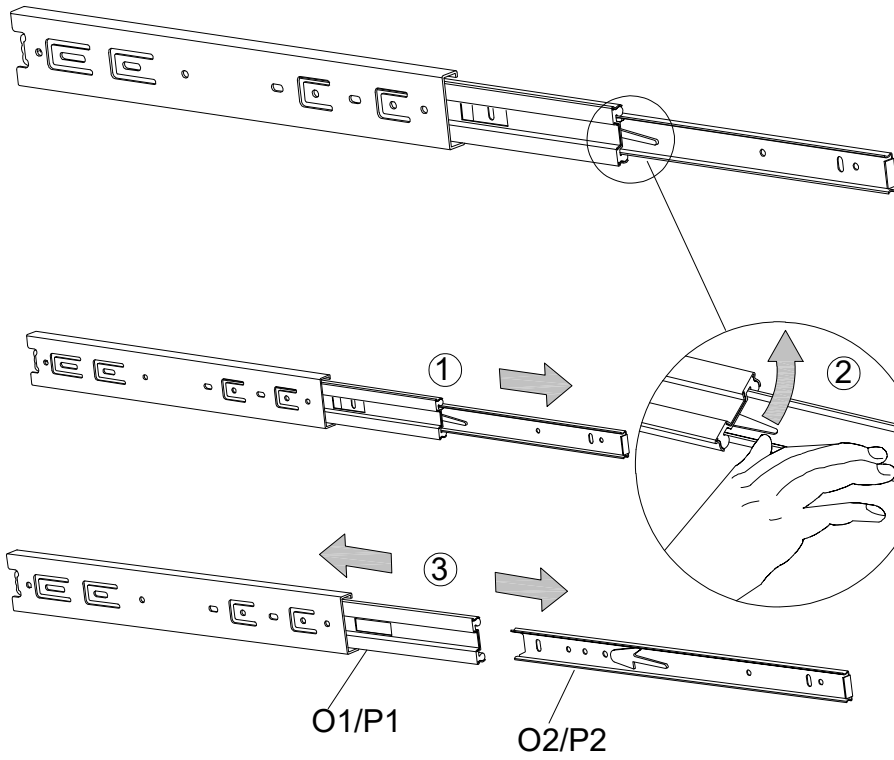

Step 2

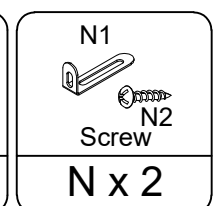
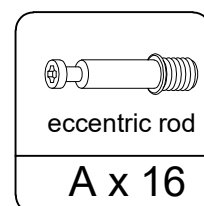
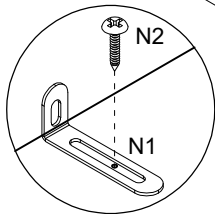
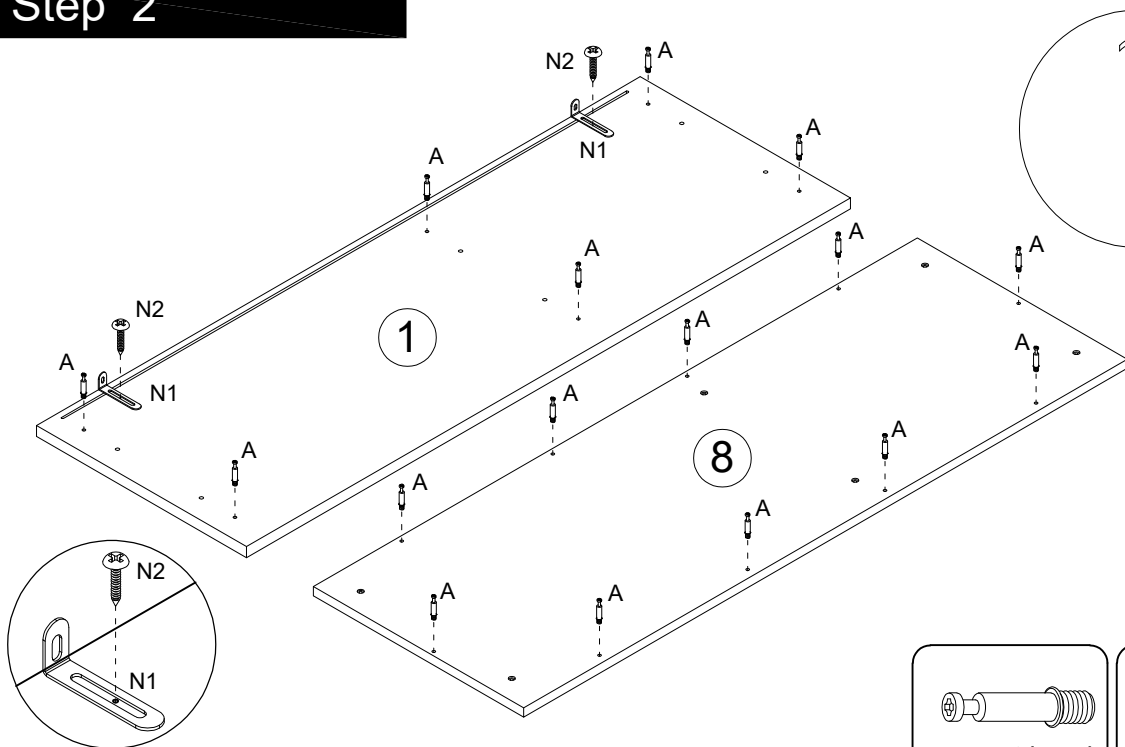

Step 3

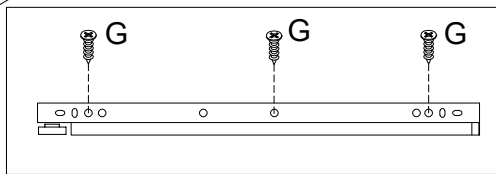
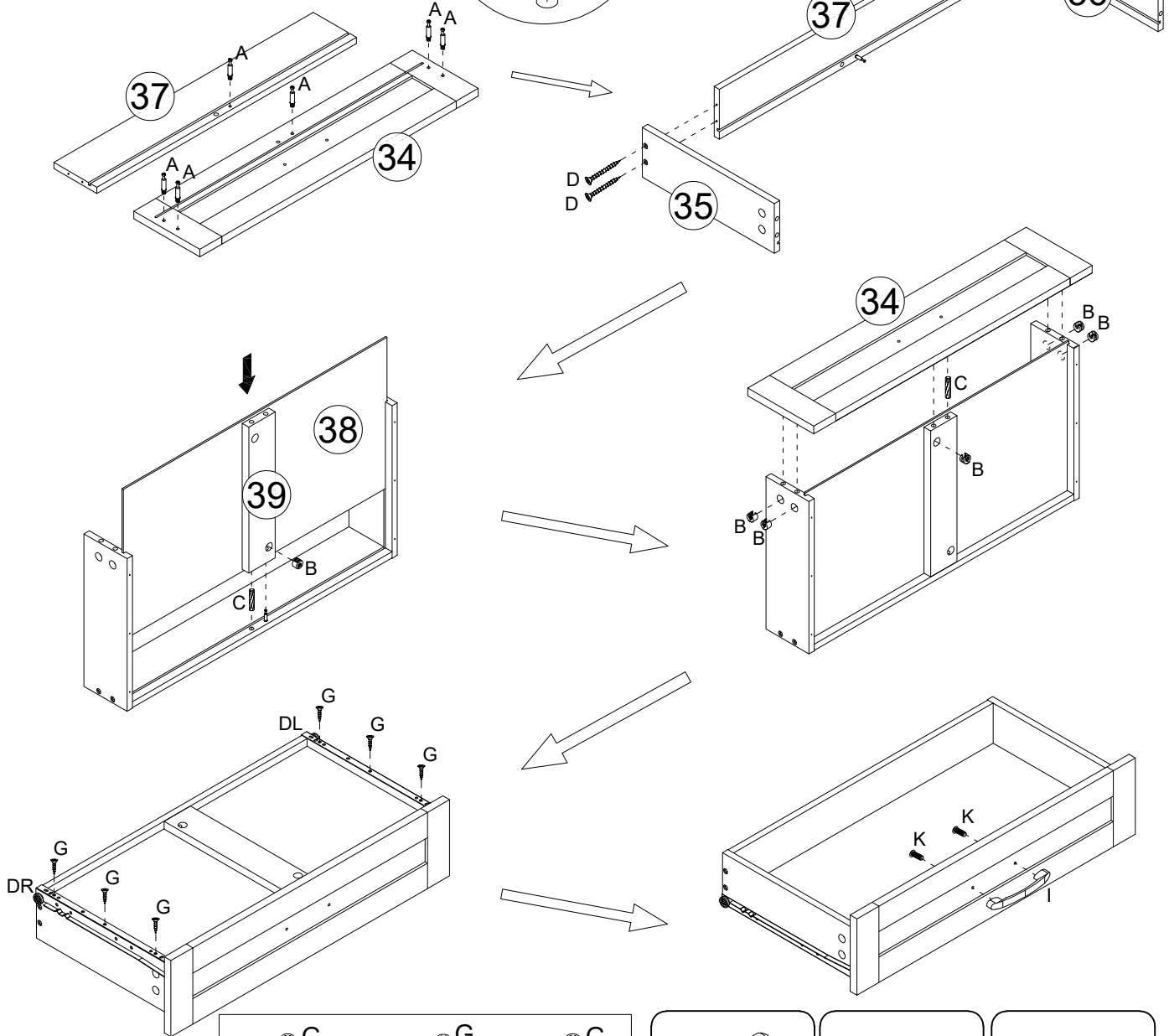
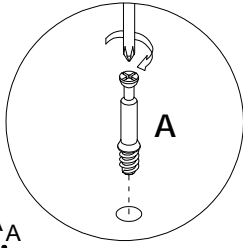
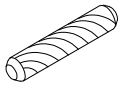
Dowels
C x 2



Handle
I x 1



Bolts
K x 2

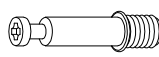

eccentric rod
A x 6

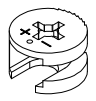

eccentric rod gear
B x 6

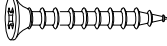

Screws
D x 4



Screws
G x 6

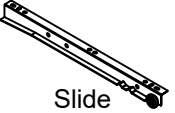

Slide
DL x 1

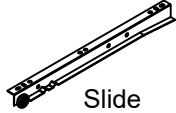

Slide
DR x 1

Step 4

x2

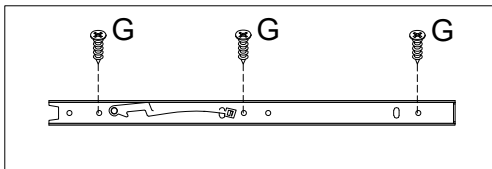
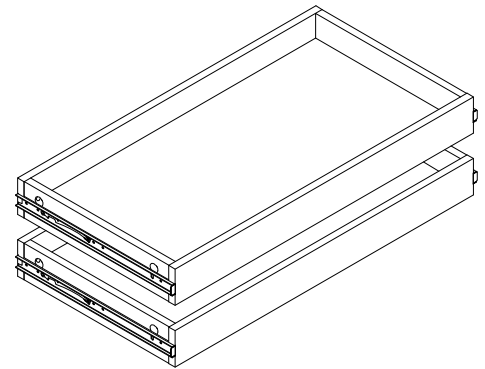
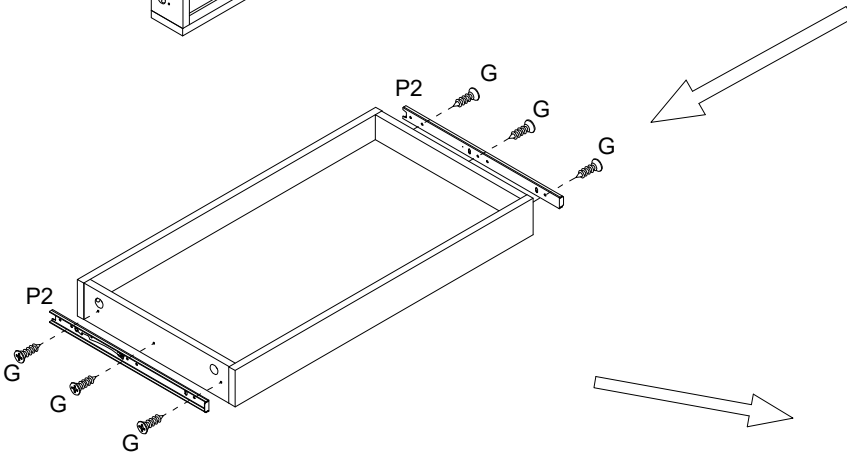
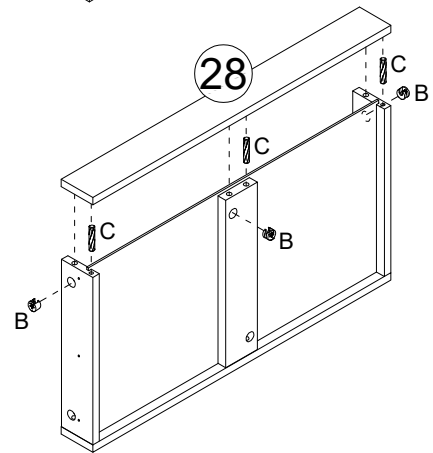
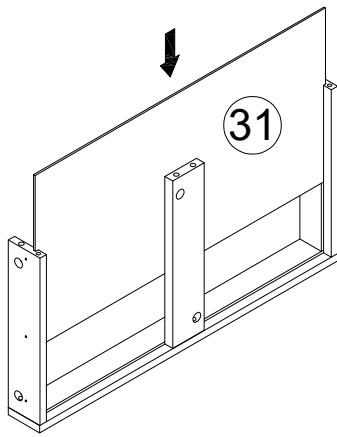
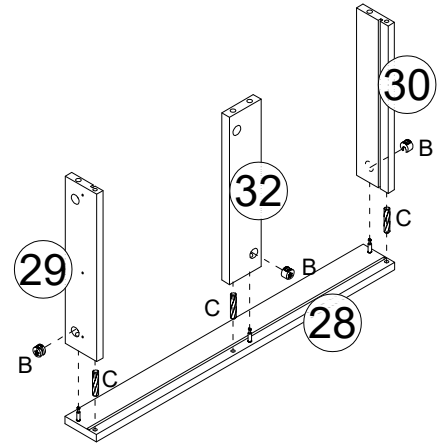
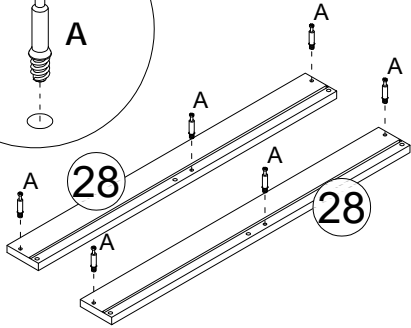
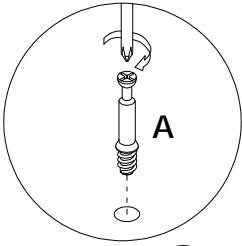

eccentric rod
A x 12

eccentric rod gear
B x 12

Dowels
C x 12

Screws
G x 12

Slide
P2 x 4

Step 5

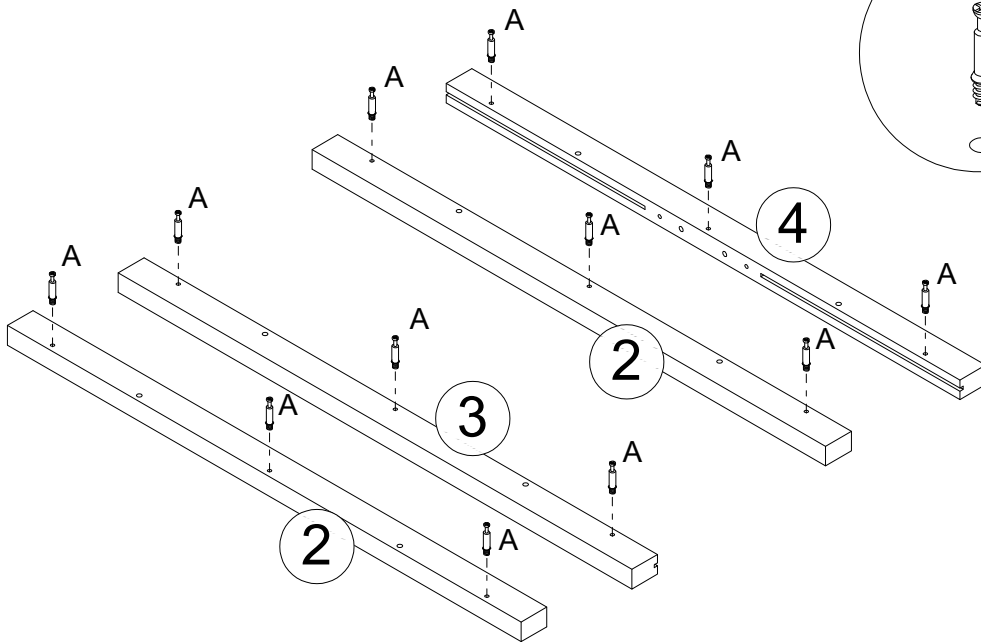

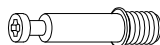

eccentric rod
A x 12

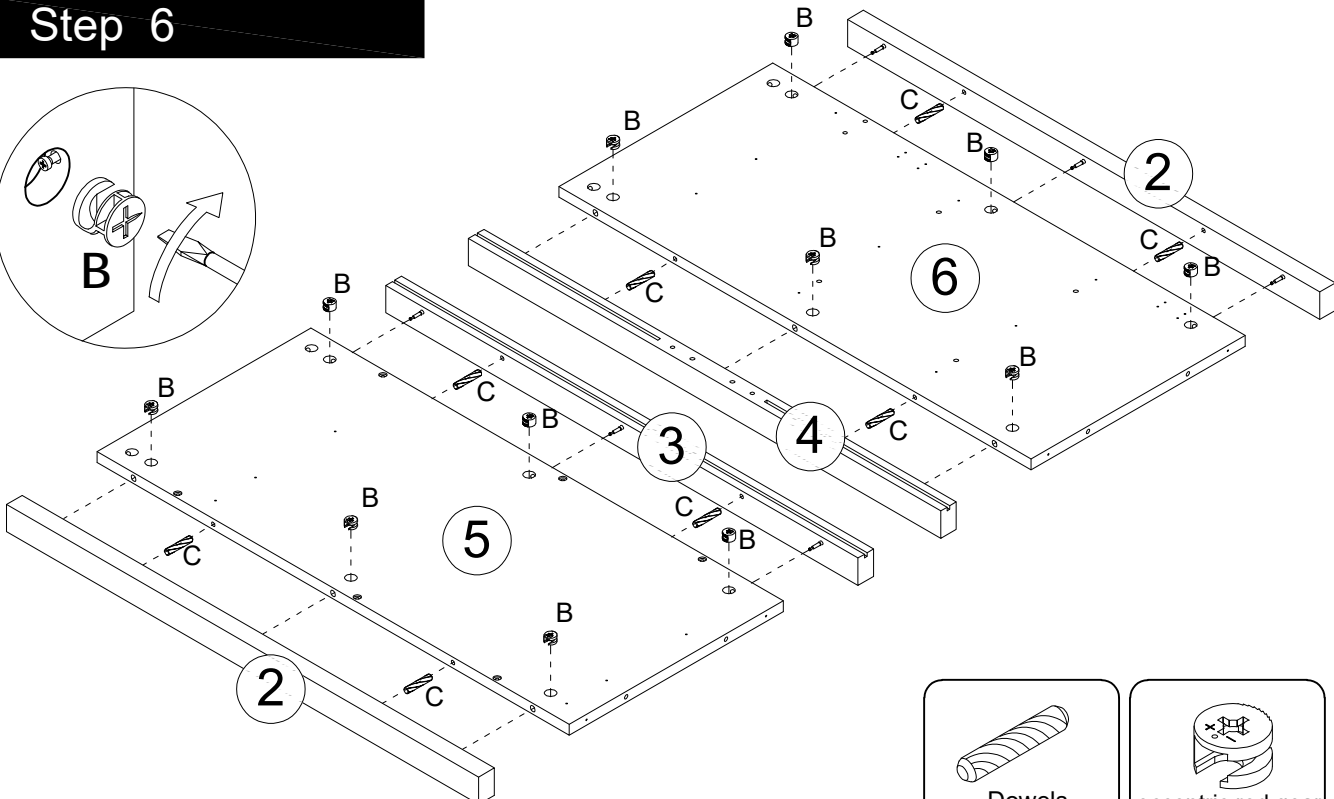
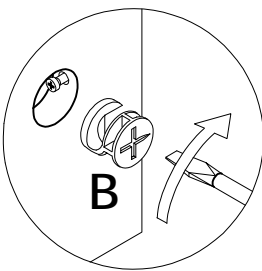
Step 6

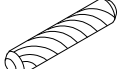



Dowels
C x 8

eccentric rod gear
B x 12

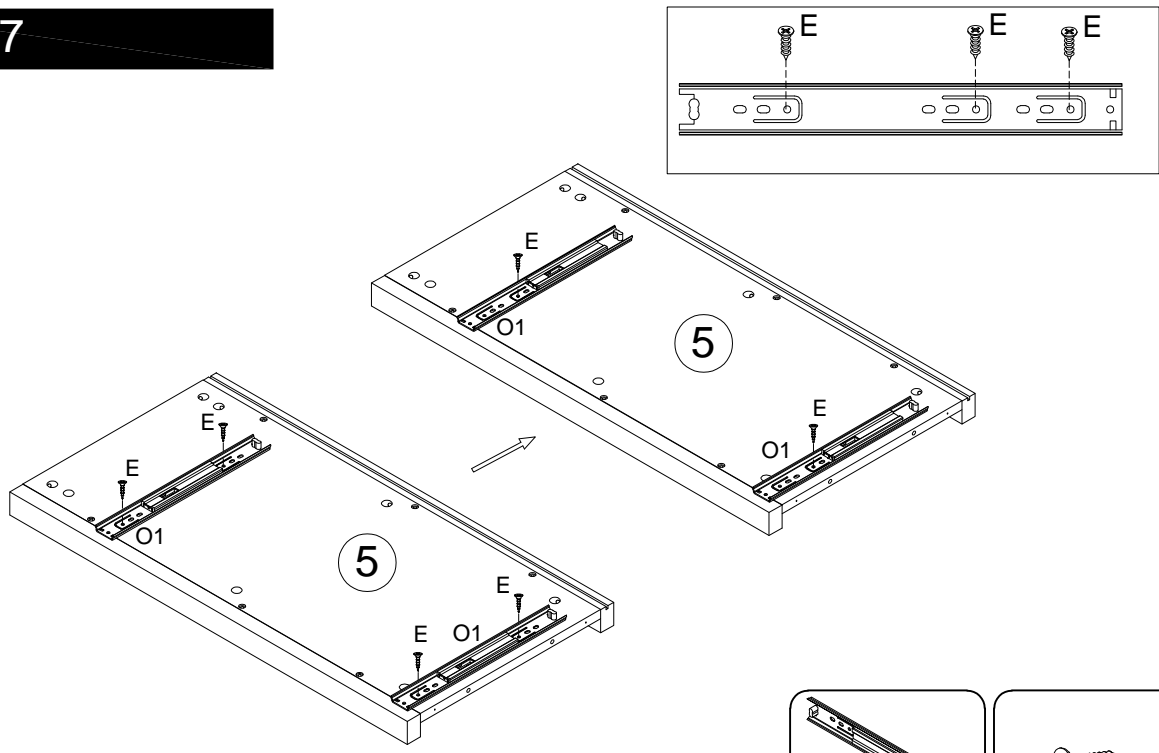
Step 7

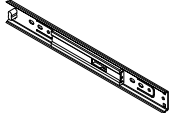

- 

Ball bearing slide
O1 x 2
- 

Screw
E x 6

Step 8

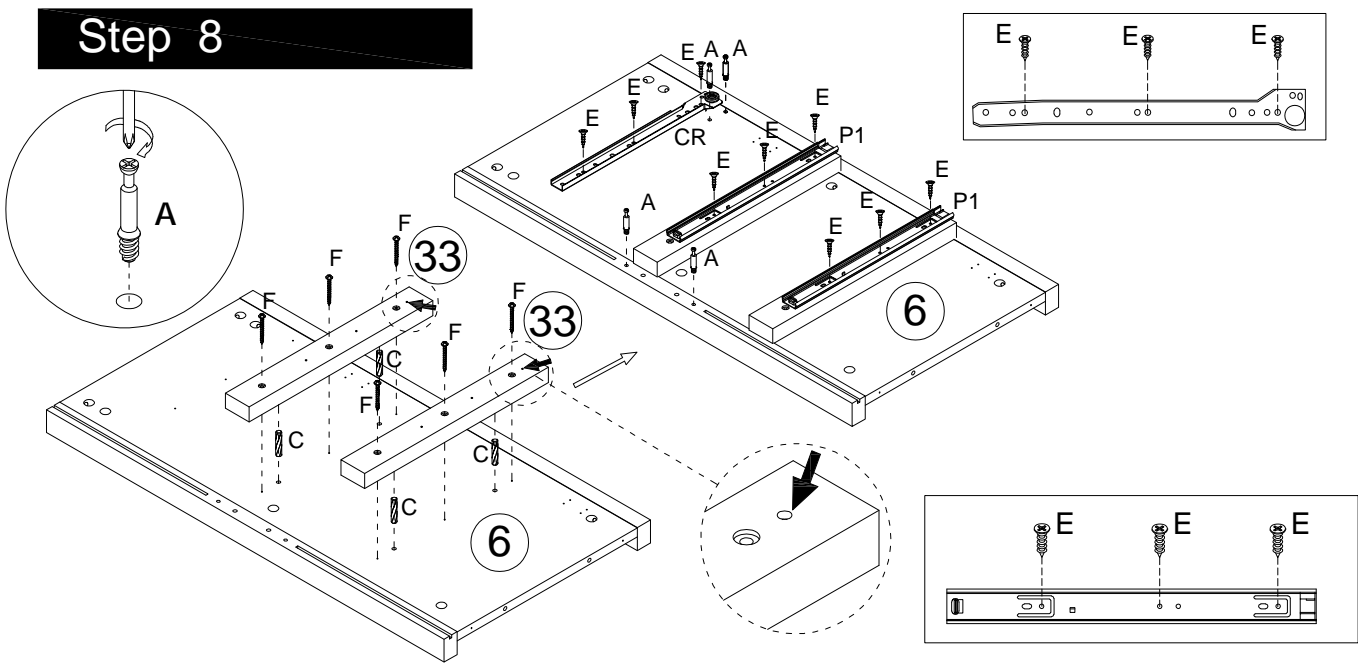

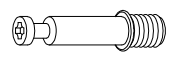
- 

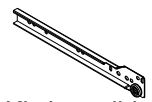
Cam lock bolt
A x 4
- 

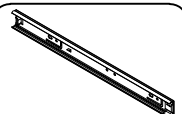
Kitchen slide
CR x 1
- 

Ball bearing slide
P1 x 2
- 

Screw
E x 9
- 

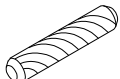
Screw
F x 6
- 

Dowel
C x 4

Step 9

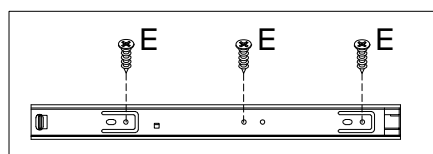
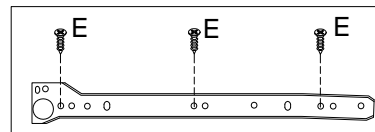
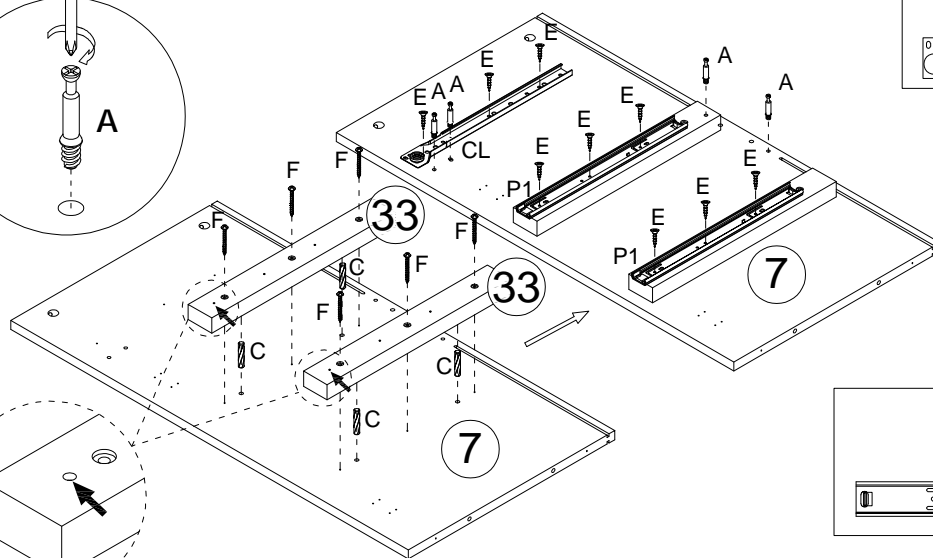
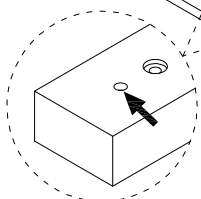
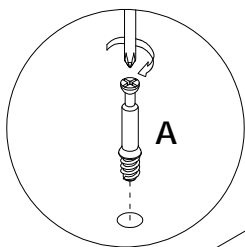

Cam lock bolt A x 4	Kitchen slide CL x 1	Ball bearing slide P1 x 2	Screw E x 9	Screw F x 6	Dowel C x 4

Step 10

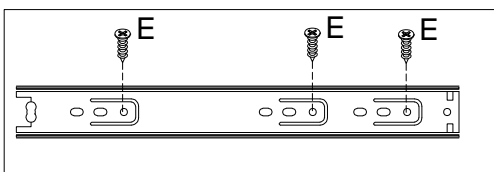
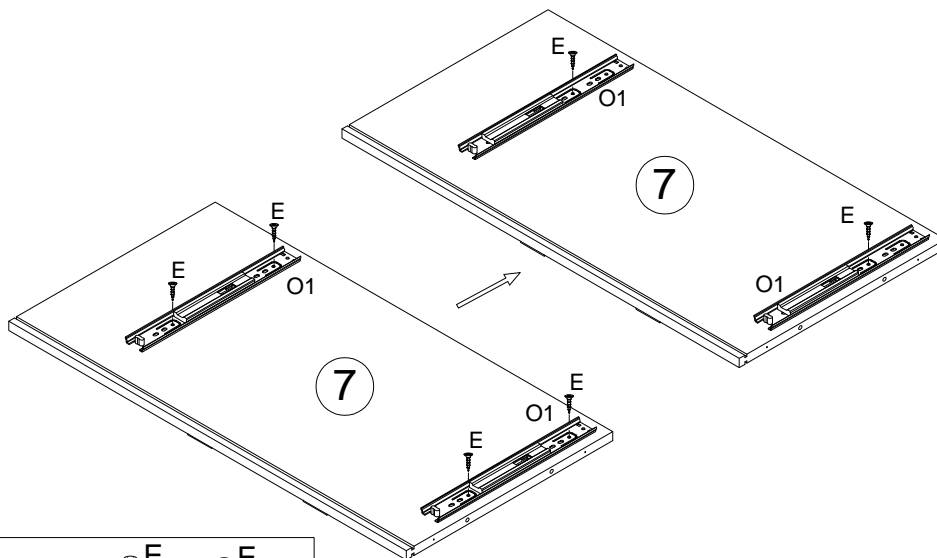

Ball bearing slide O1 x 2	Screw E x 6

Step 11

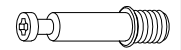
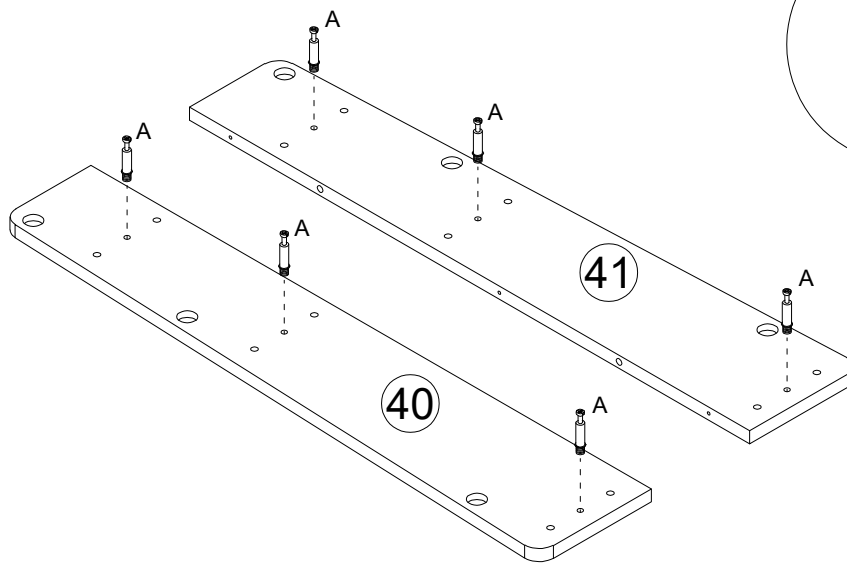

eccentric rod

A x 6

Step 12

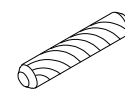
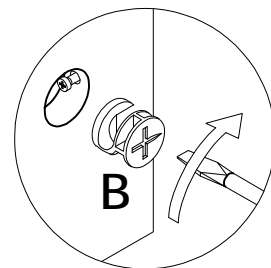
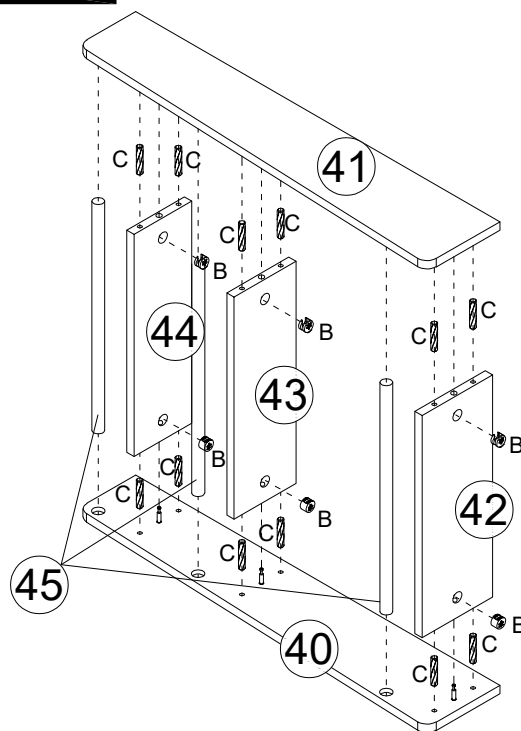
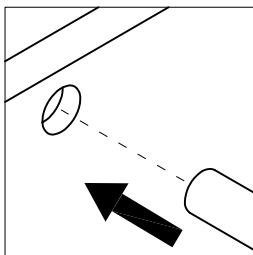

Dowels

C x 12



eccentric rod gear

B x 6

Step 13

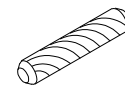
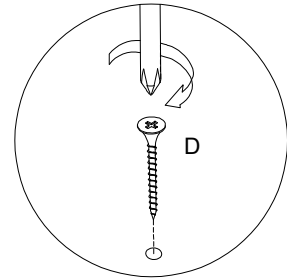
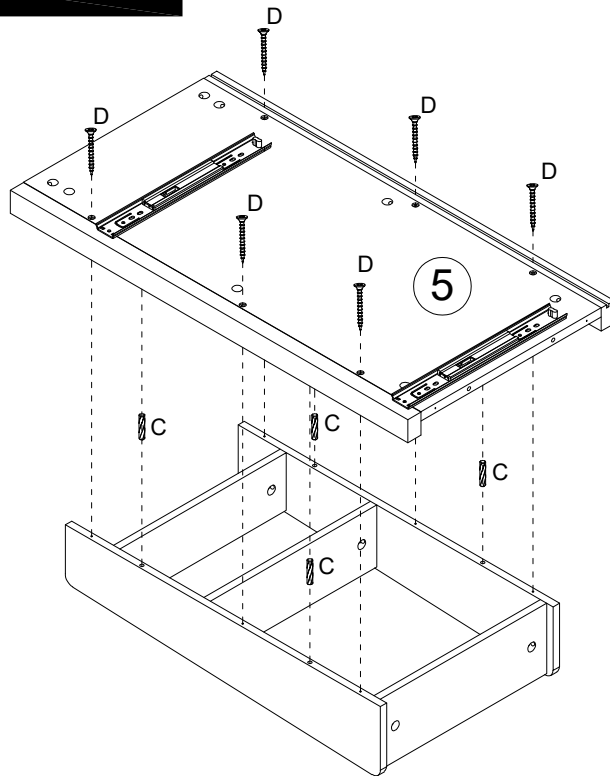

Dowels

C x 4

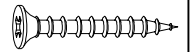

Screws

D x 6

Step 14

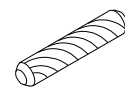
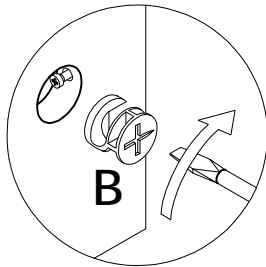
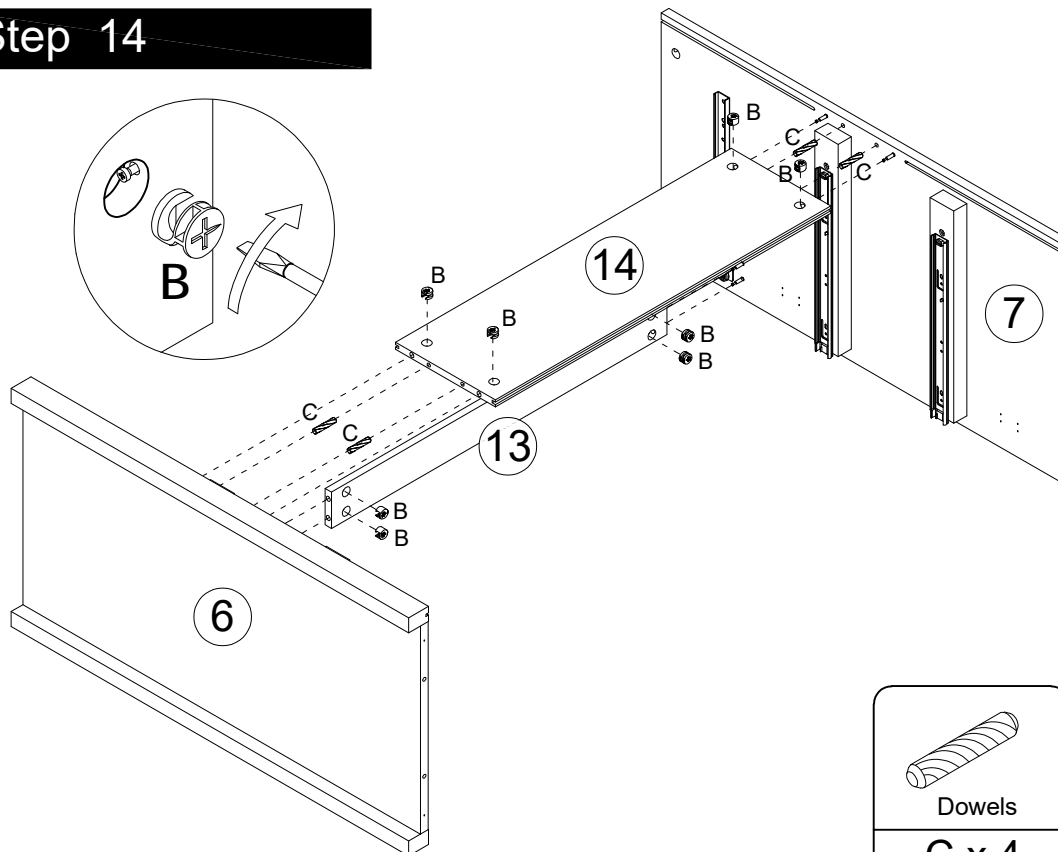

Dowels

C x 4

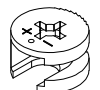

eccentric rod gear

B x 8

Step 15

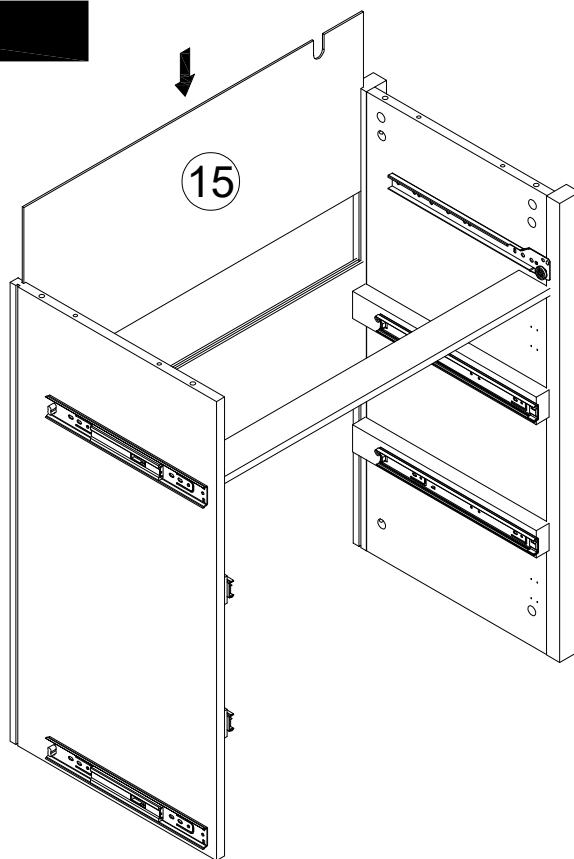

Step 16

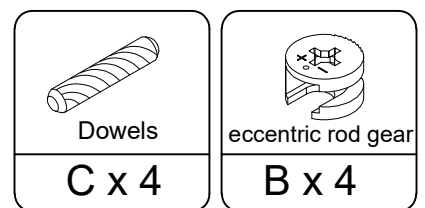
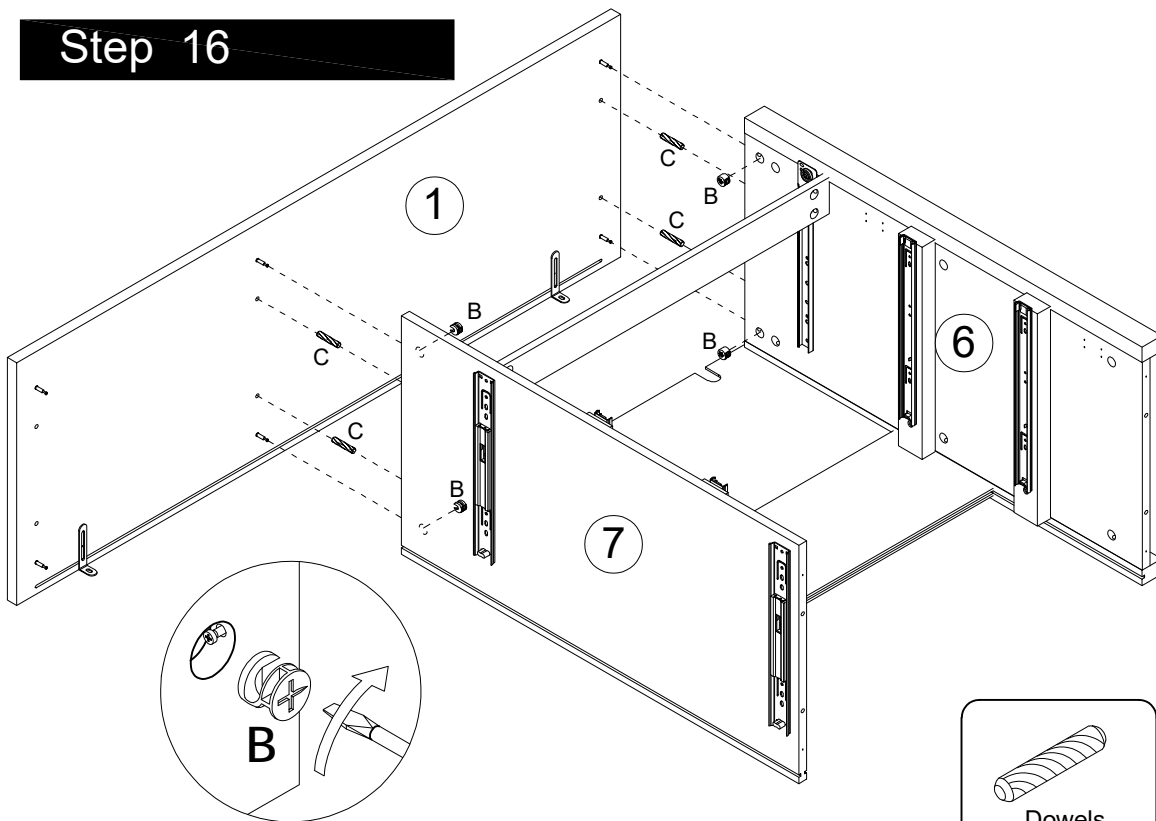

Step 17

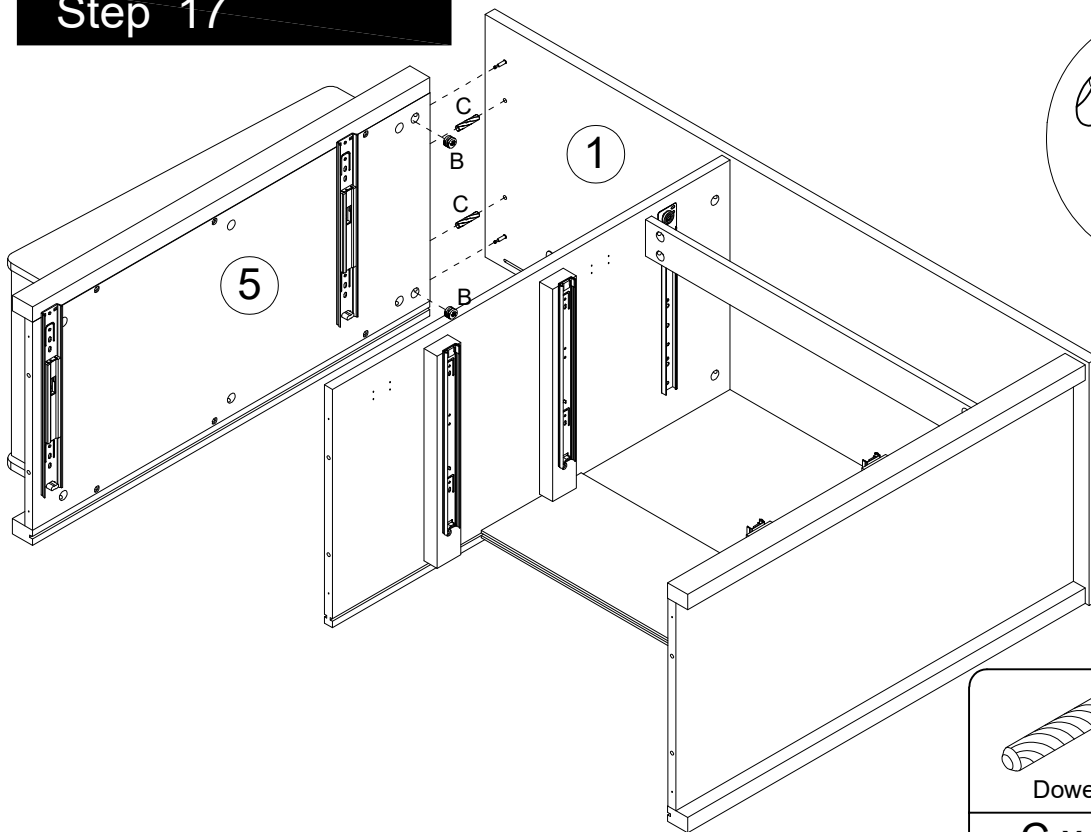

Step 18

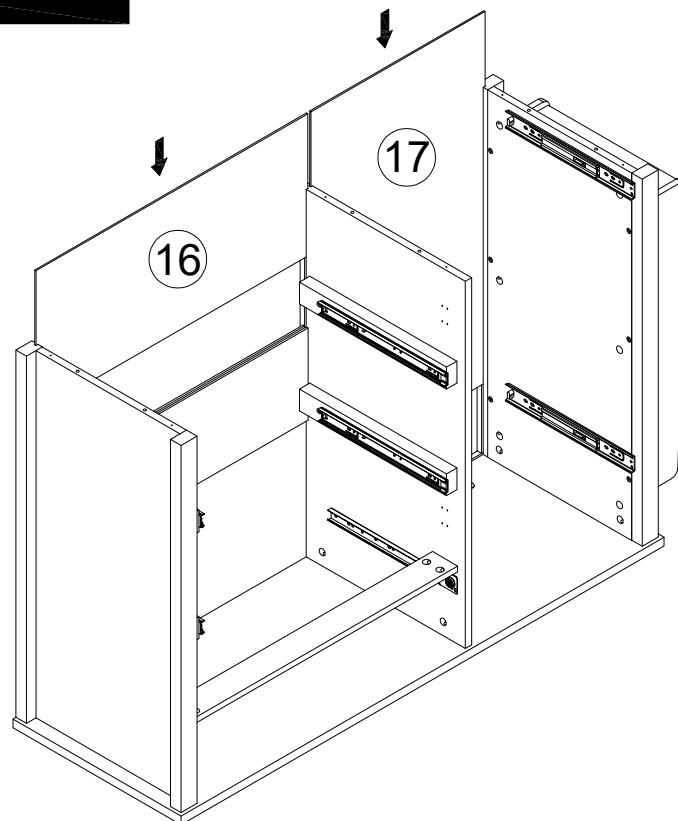

Step 19

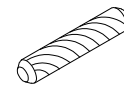
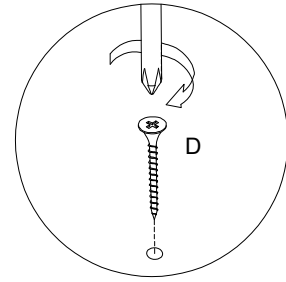
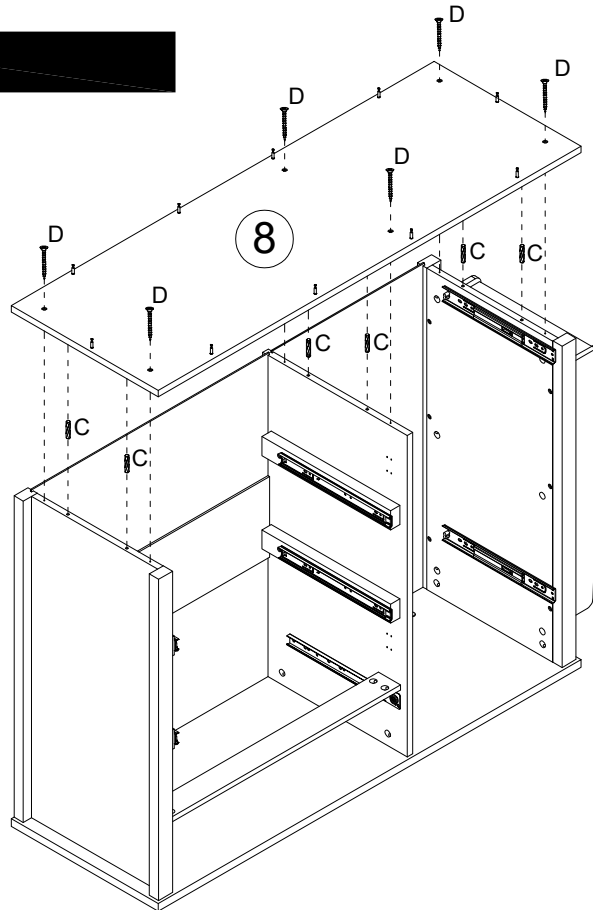

Dowels

C x 6

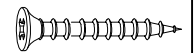

Screws

D x 6

Step 20

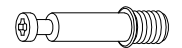
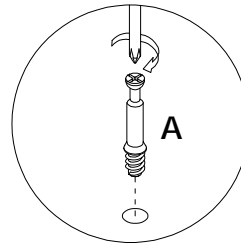
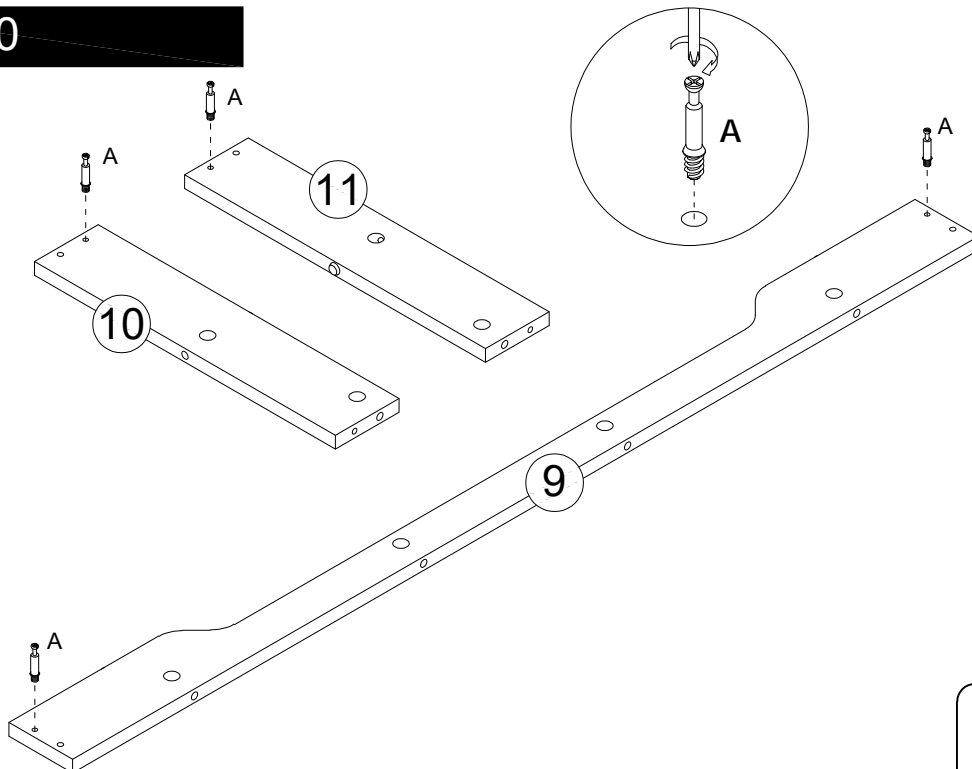

eccentric rod

A x 4

Step 21

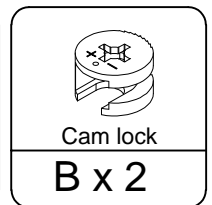
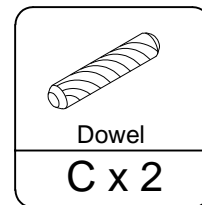
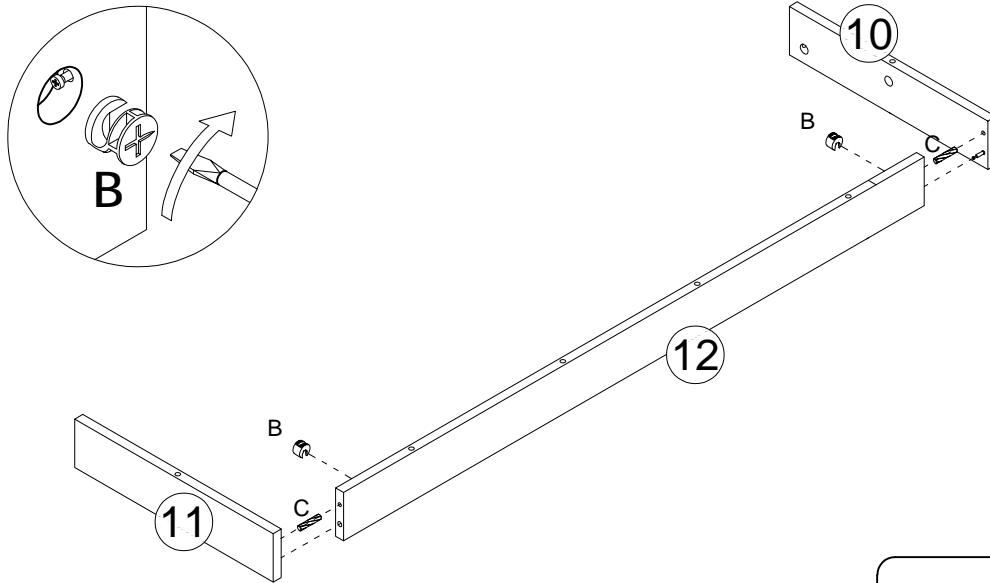

Step 22

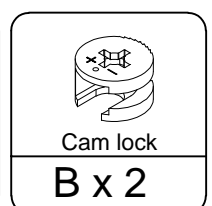
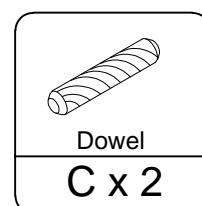
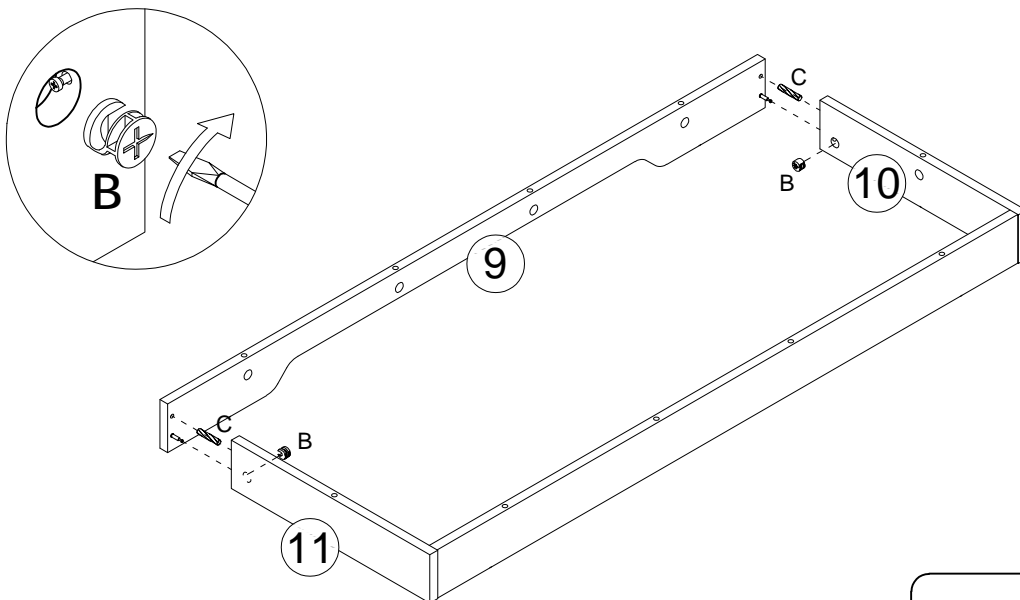

Step 23

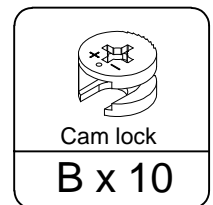
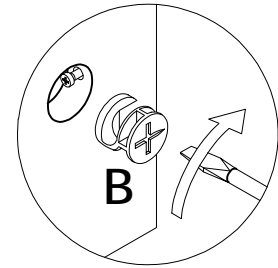
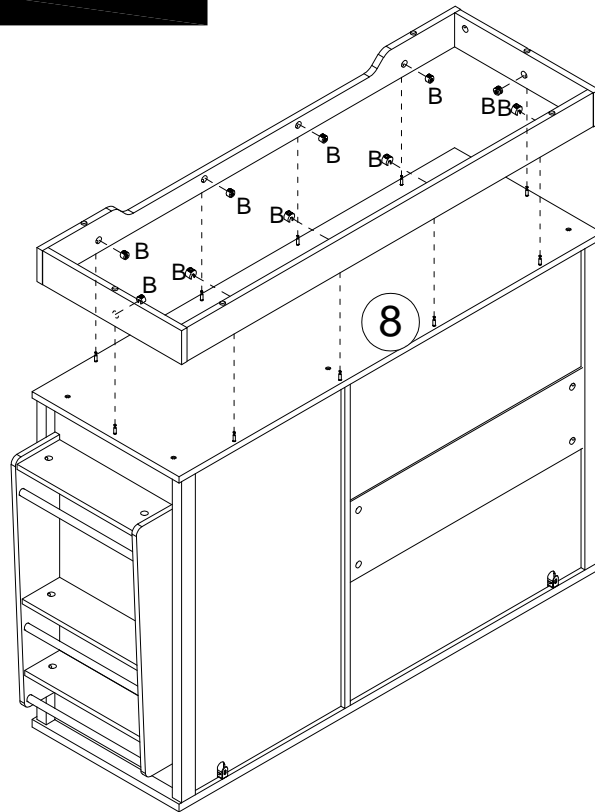

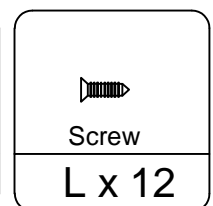
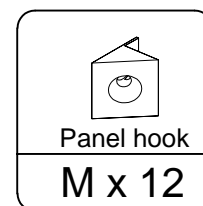
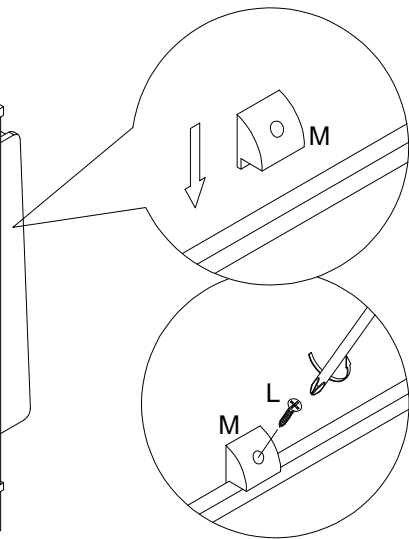
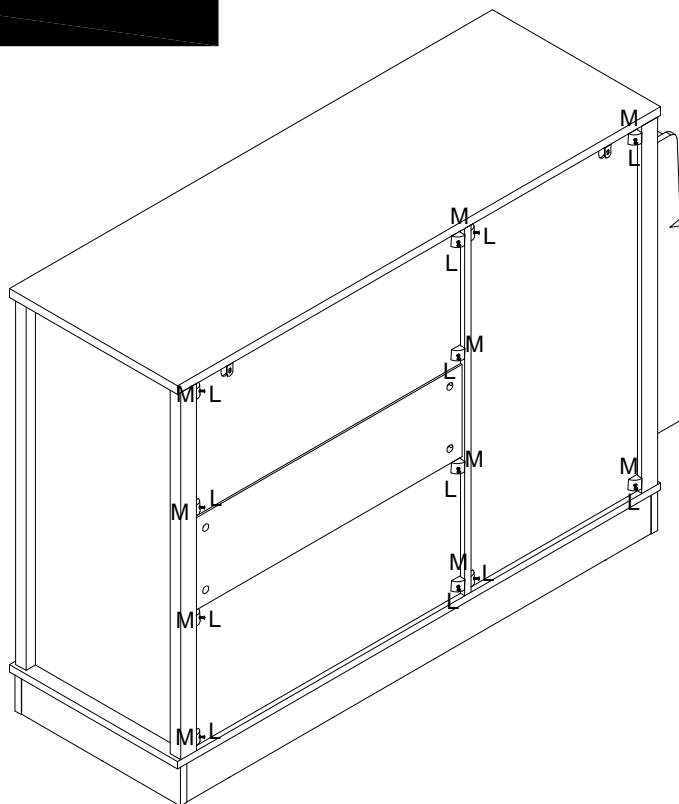

Step 24

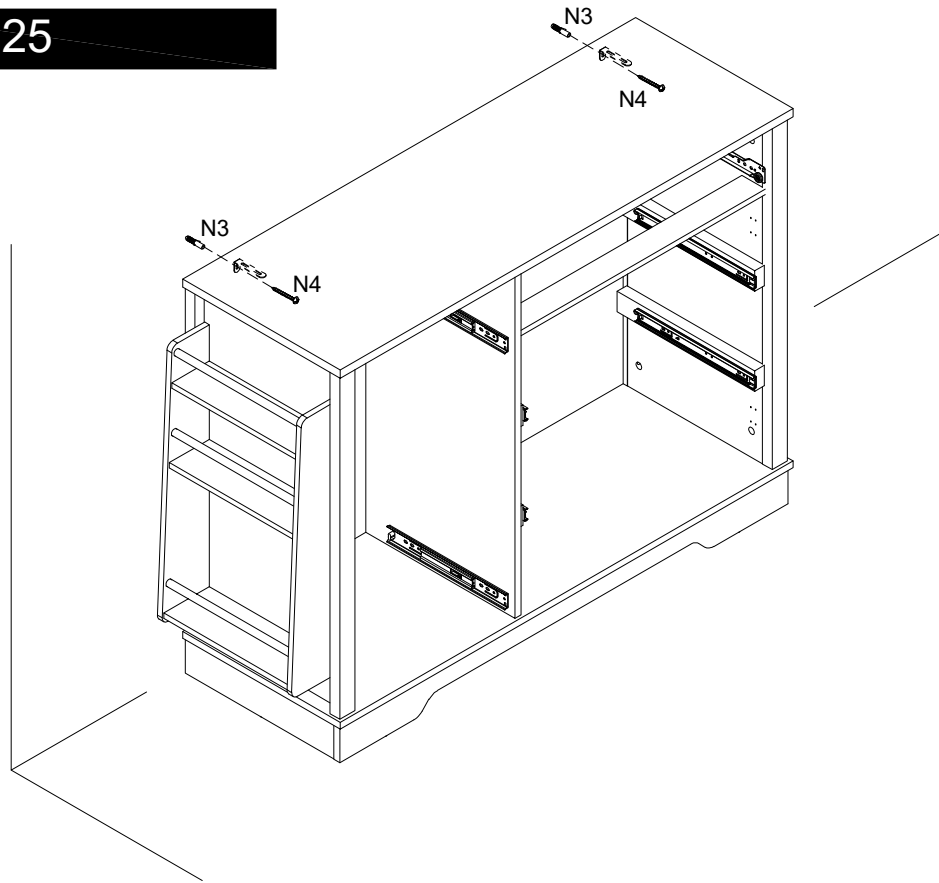

Step 25





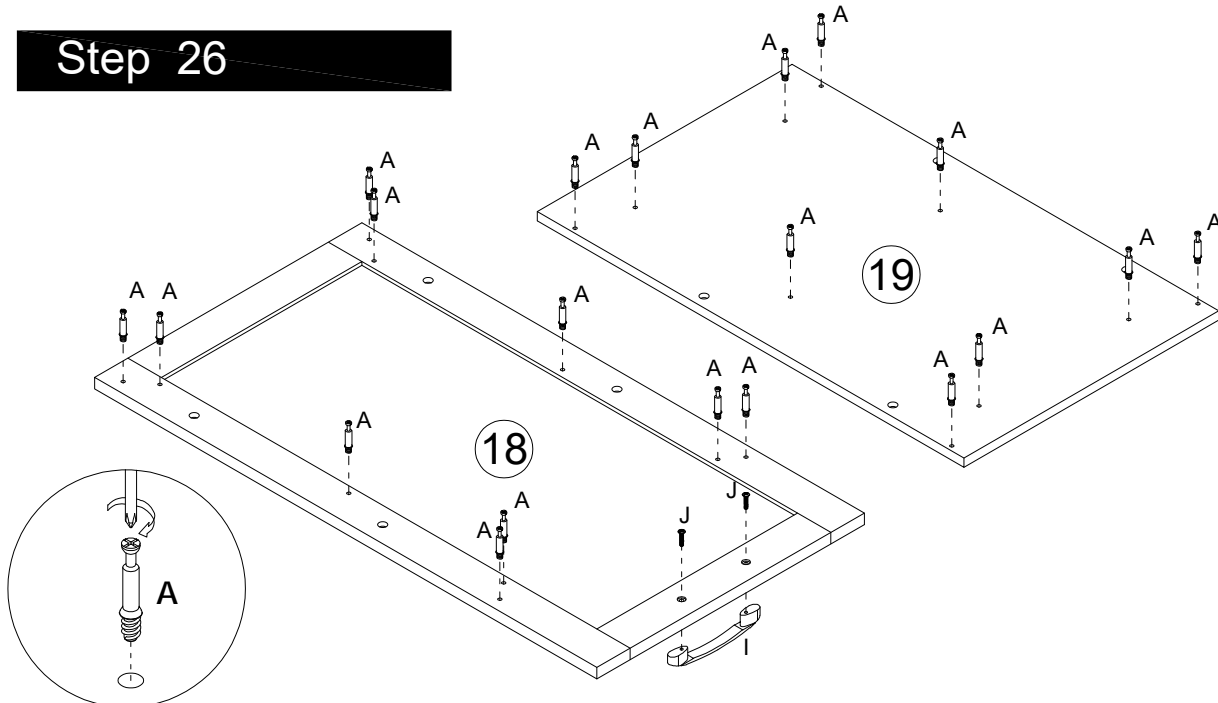

N4 Screws
N x 2

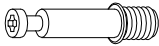
Step 26

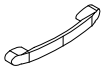



eccentric rod A x 20

Handle I x 1

Bolts J x 2

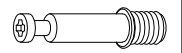
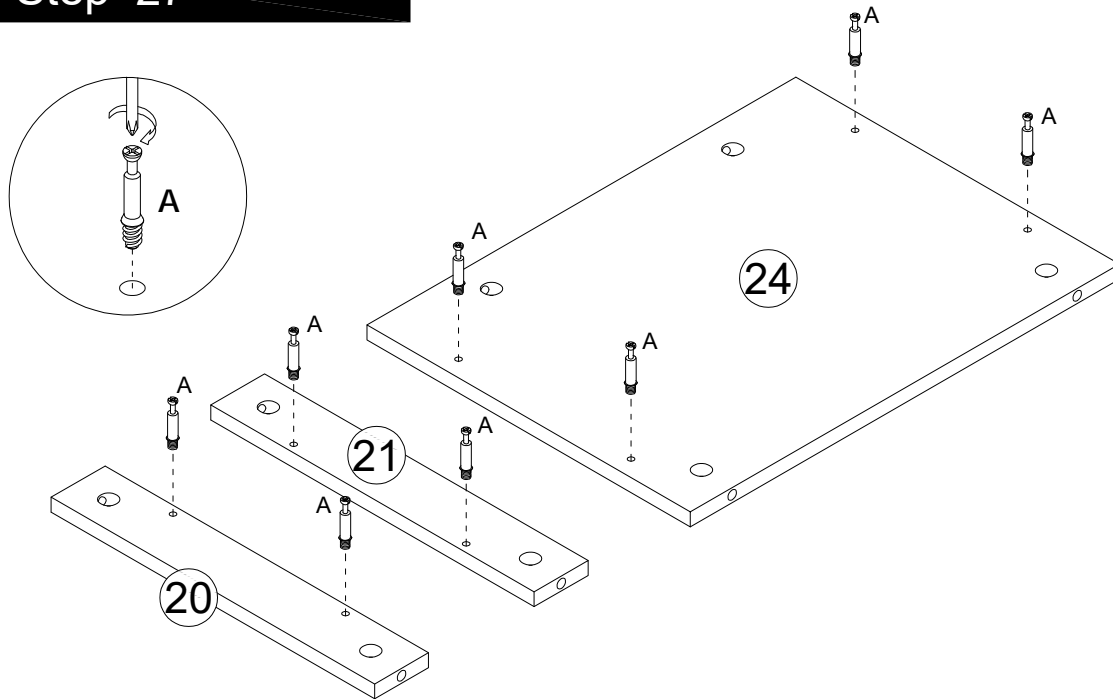
Step 27



eccentric rod

A x 8

Step 28

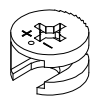
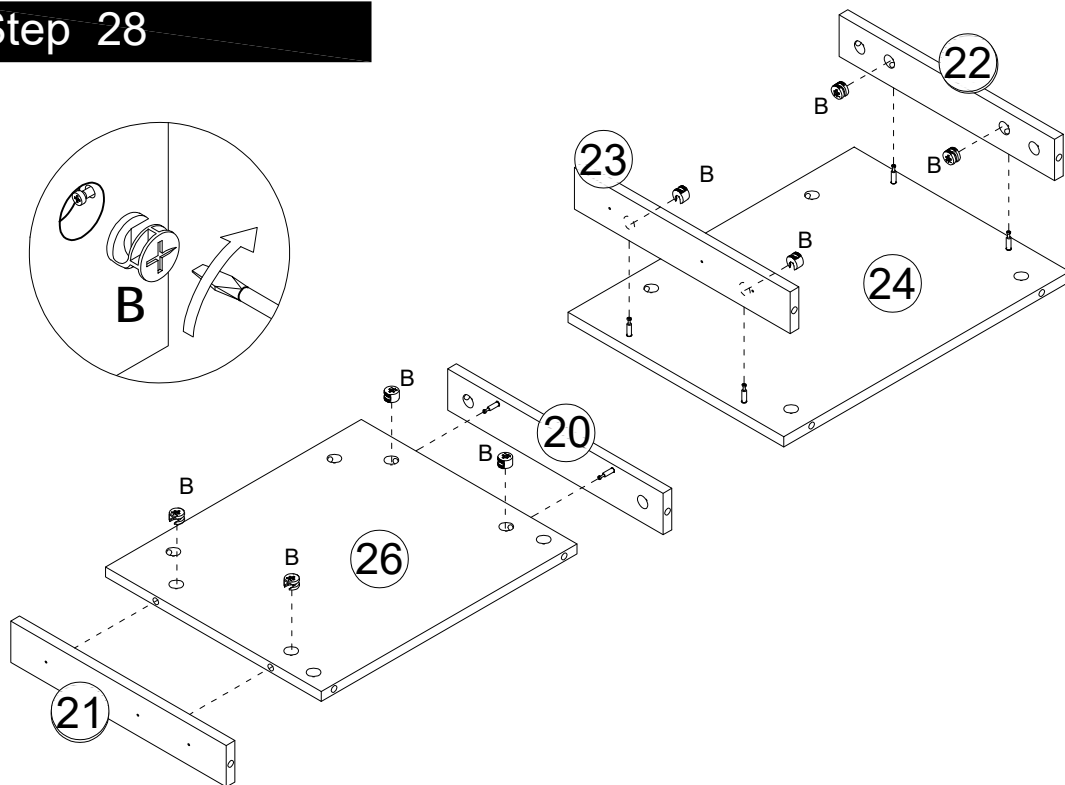

eccentric rod gear

B x 8

Step 29

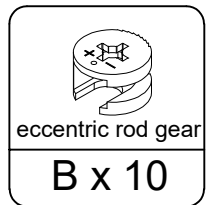
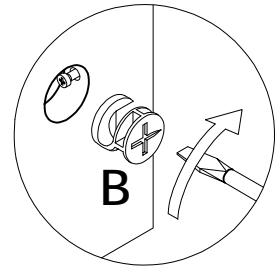
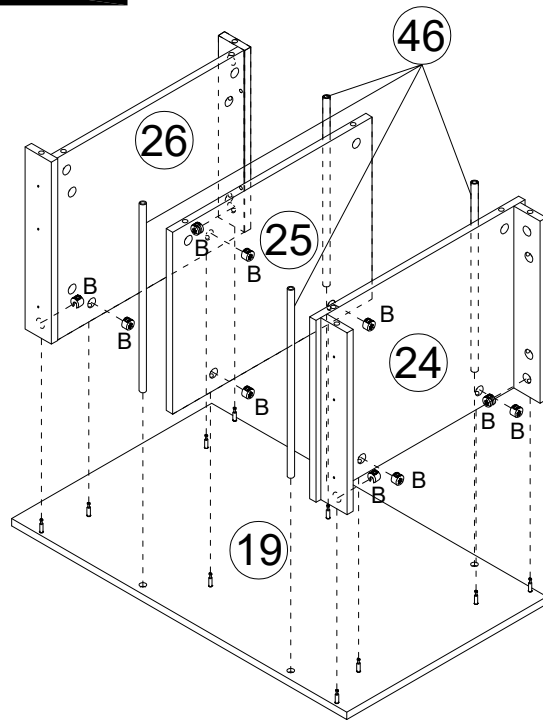
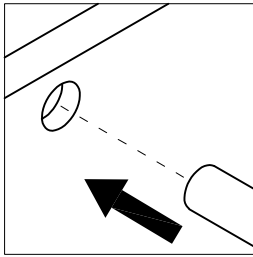

Step 30

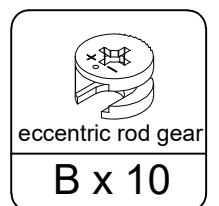
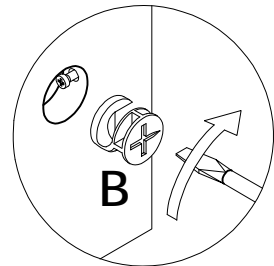
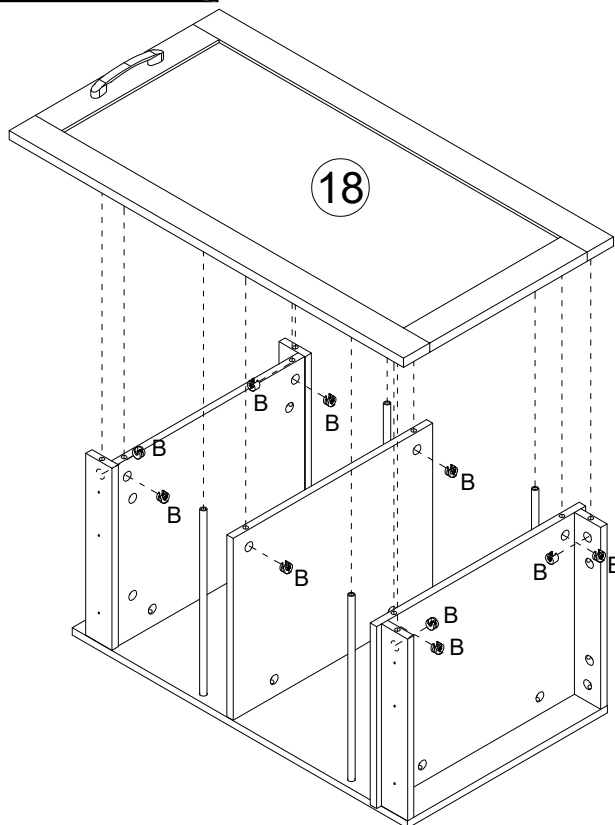

Step 31

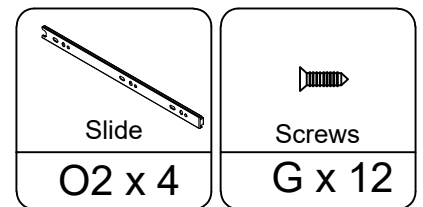
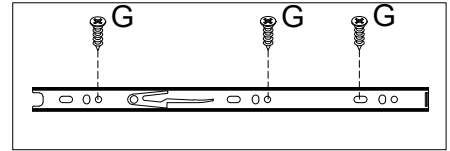
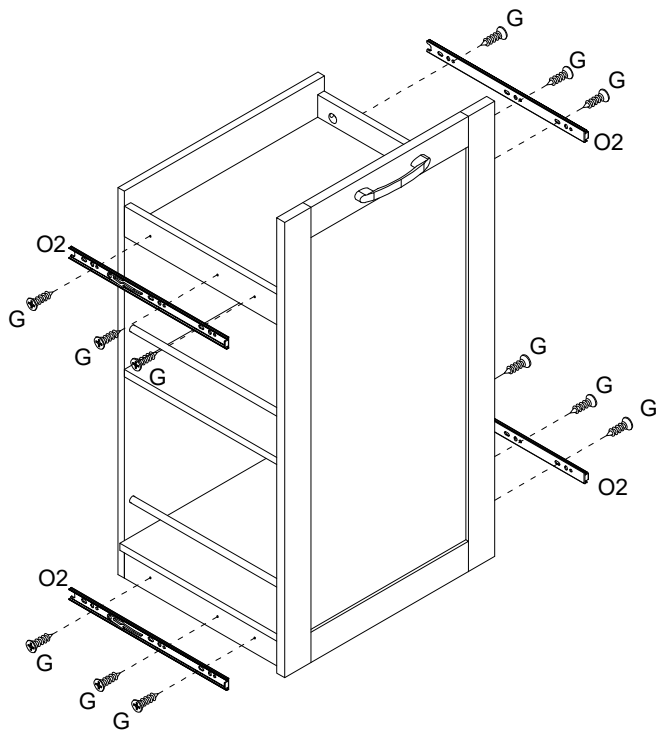

Step 32

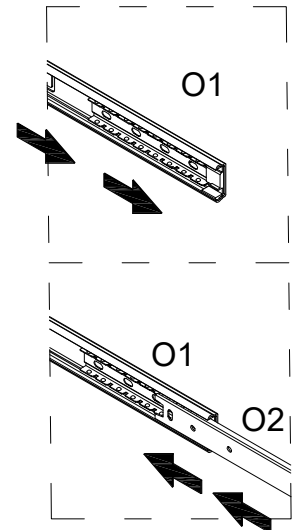
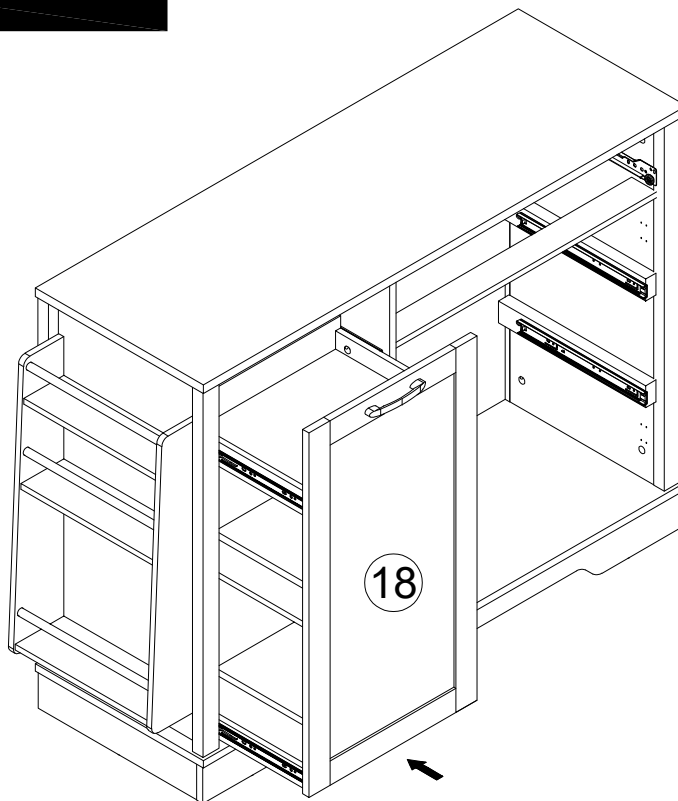

Step 33

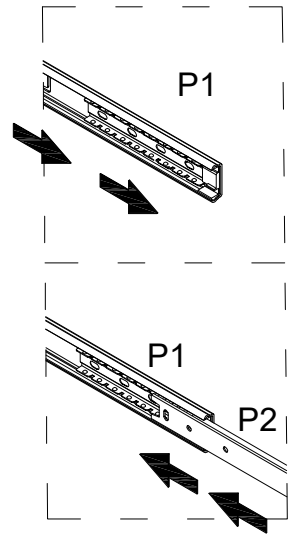
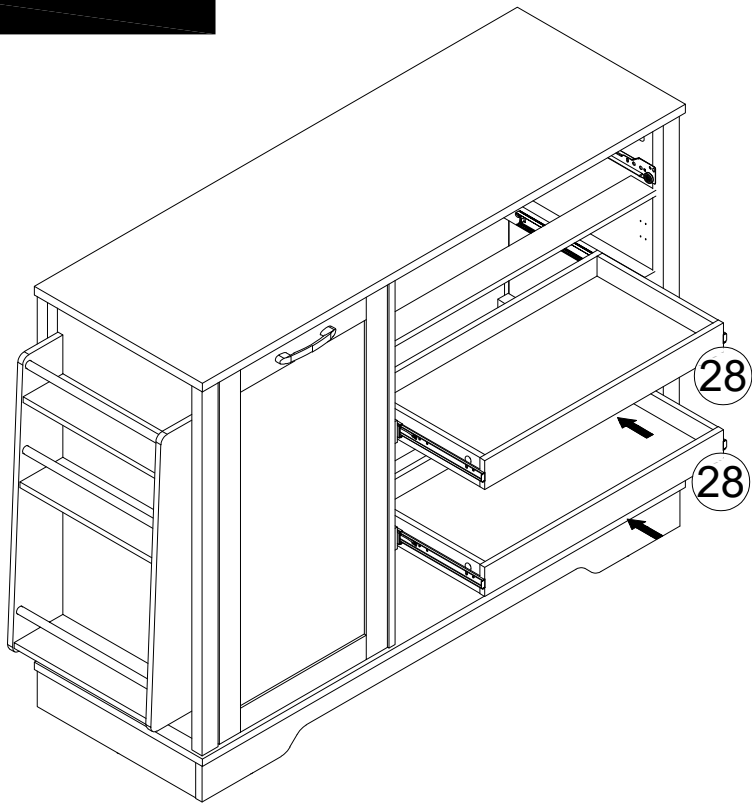

Step 34

x2

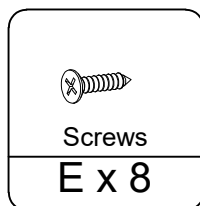
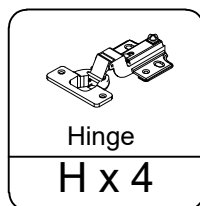
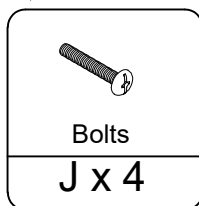
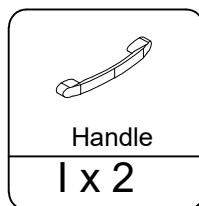
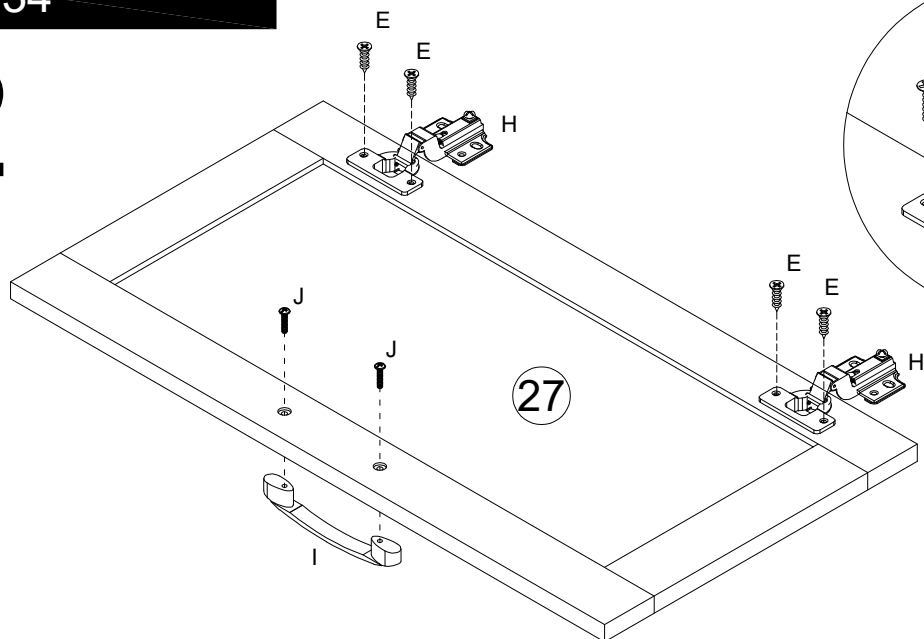

Step 35

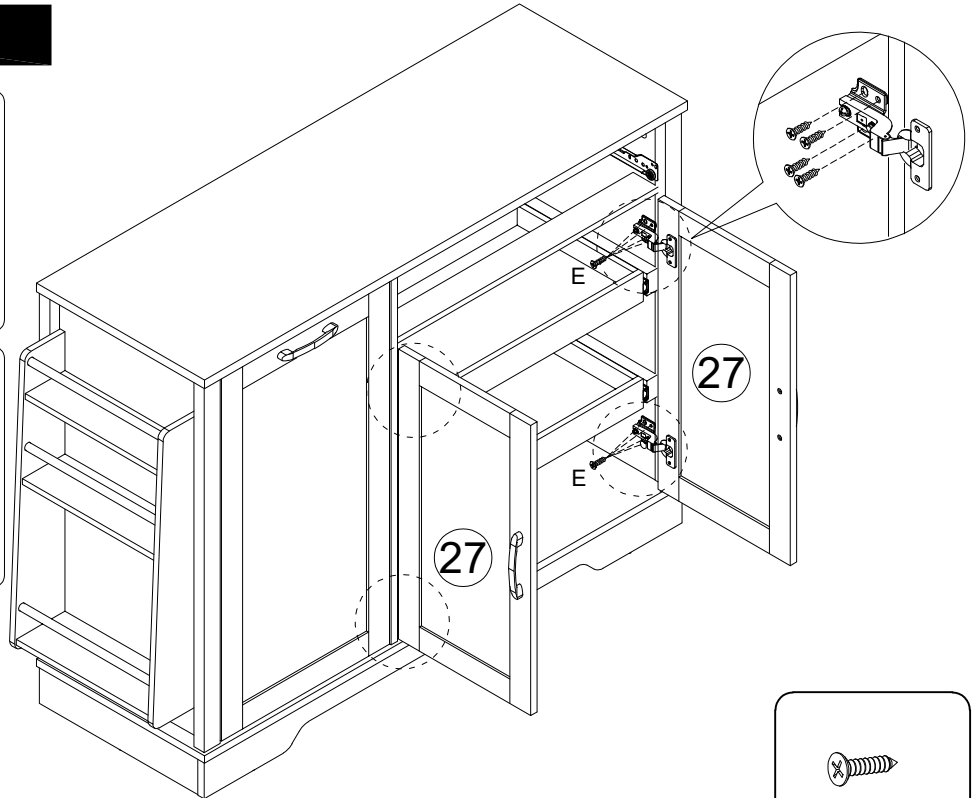
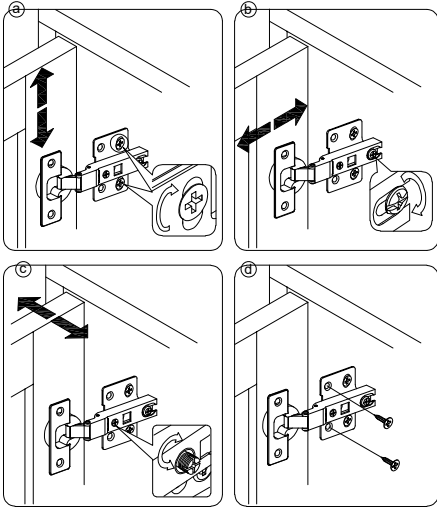

Screws

E x 16

Step 36

