

Installation sanleitung Installation Instruction Instruction d'installation

SKU:N623P460032 / N623P460033

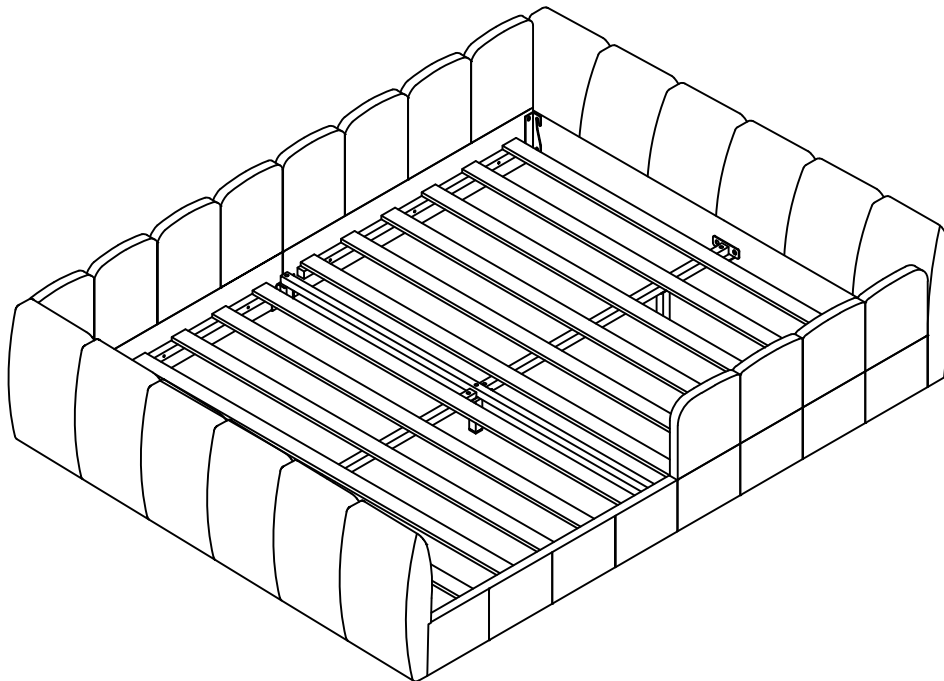

DE:Unser Produkt wird Ihnen in 2 Paketen geliefert. Die Lieferzeiten dieser 2 Pakete können abweichen, bitte haben Sie etwas Geduld und vielen Dank für Ihr Verständnis.

UK:Our product will be delivered to you in 2 packages. The delivery times of these 2 packages may differ, please be patient and thank you for your understanding.

FR:Notre produit vous sera livré en 2 colis. Les délais de livraison de ces 2 colis peuvent différer, soyez patient et merci pour votre compréhension.

English

IMPORTANT FOR GAS LIFT BEDS&MAINTAINCE

- Please place the mattress on top of the bed frame.
- Please do not pull on the strap handles.
- Please press heavily to release the compressed gas.
- Periodically check all screw & fixings to ensure they are secure.
- When moving your product, carefully lift into place.
- Wipe clean with a slightly damp cloth- please do not use abrasive chemicals or bleach.
- Do NOT allow children to operate the lift mechanism.
- Do NOT allow children near the lift base when operating the mechanism.
- Do NOT stand inside the bed or the internal storage base.
- Do NOT overload the internal storage base.
- DO NOT jump on the product or any of its parts.

Deutsch

WICHTIG FÜR GASLIFT-BETTEN&WARTUNG

- Bitte legen Sie die Matratze oben auf den Bettrahmen.
- Bitte ziehen Sie nicht an den Gurtgriffen.
- Bitte drücken Sie kräftig, um das komprimierte Gas freizusetzen.
- Überprüfen Sie regelmäßig alle Schrauben und Befestigungen, um sicherzustellen, dass sie sicher sind.
- Wenn Sie Ihr Produkt bewegen, heben Sie es vorsichtig an seinen Platz.
- Mit einem leicht feuchten Tuch abwischen - bitte keine scheuernden Chemikalien oder Bleichmittel verwenden.
- Erlauben Sie Kindern NICHT, den Hebemechanismus zu bedienen.
- Lassen Sie Kinder NICHT in die Nähe des Liftsockels, wenn Sie den Mechanismus bedienen.
- Stellen Sie sich NICHT in das Bett oder in die Innenablage.
- Überlasten Sie den internen Liftsockel NICHT.
- Springen Sie NICHT auf das Produkt oder eines seiner Teile.

Français

IMPORTANT POUR LES LITS À RELEVAGE DE GAZ&MAINTENANCE

- Veuillez placer le matelas sur le dessus du cadre de lit.
- Ne tirez pas sur les poignées de la sangle.
- Appuyez fortement pour libérer le gaz comprimé.
- Vérifiez régulièrement que toutes les vis et fixations sont bien en place.
- Lorsque vous déplacez votre produit, soulevez-le avec précaution pour le mettre en place.
- Nettoyez avec un chiffon légèrement humide - n'utilisez pas de produits chimiques abrasifs ou d'eau de Javel.
- Ne laissez pas les enfants utiliser le mécanisme de levage.
- Ne laissez pas les enfants s'approcher de la base de levage lorsqu'ils actionnent le mécanisme.
- Ne vous tenez PAS à l'intérieur du lit ou de la base de stockage interne.
- Ne surchargez pas la base de stockage interne.
- Ne pas sauter sur le produit ou l'une de ses parties.

Italiano

IMPORTANTE! CONSERVARE PER RIFERIMENTO FUTURO: LEGGERE ATTENTAMENTE

- Deve essere assemblato da un adulto. L'assemblaggio deve essere controllato da un adulto prima dell'uso
- **ATTENZIONE!** Tenere tutte le viti, le piccole parti e i sacchetti di plastica fuori dalla portata dei bambini
- Identificare correttamente tutte le parti prima dell'assemblaggio
- Non utilizzare mai l'articolo se alcune parti sono rotte o mancanti
- In caso di problemi, si prega di contattare il nostro Servizio Post Vendita
- Le istruzioni del produttore devono essere sempre seguite
- Cura: Pulire con un panno morbido e asciutto. In caso di macchie più estese, strofinare accuratamente con una spugna leggermente umida e nonspugna leggermente umida e non abrasiva
- Evitare il rischio di incendio, non collocando i mobili vicino a fonti di accensione o a oggetti caldi
- Non saltare sul letto

Español

¡ IMPORTANTE ! CONSERVELO PARA FUTURAS CONSULTAS: LEA ATENTAMENTE

- Debe ser montado por un adulto. El montaje debe ser comprobado por un adulto antes del uso
- ADVERTENCIA Mantenga todos los tornillos, piezas pequeñas y bolsas de plástico fuera del alcance de los niños.
- Identifique correctamente todas las piezas antes de montarlas
 - Nunca utilice su artículo si alguna de sus piezas está rota o falta
 - Si surge algún problema, póngase en contacto con nuestro Servicio Postventa
 - Las instrucciones del fabricante deben seguirse en todo momento
 - Cuidado: Limpiar con un paño suave y seco. En caso de manchas más grandes, frote cuidadosamente con una esponja no abrasiva ligeramente humedecida.
 - Evite el riesgo de incendio no colocando los muebles cerca de fuentes de ignición u objetos calientes.
 - No saltar sobre la cama.

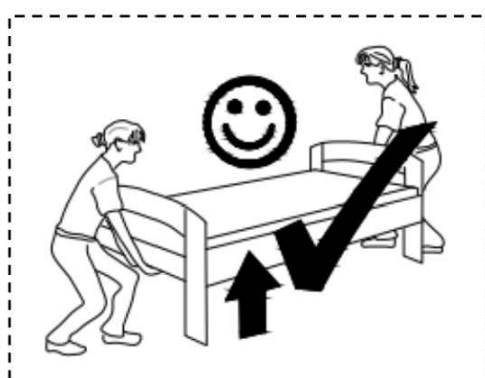

Detail View

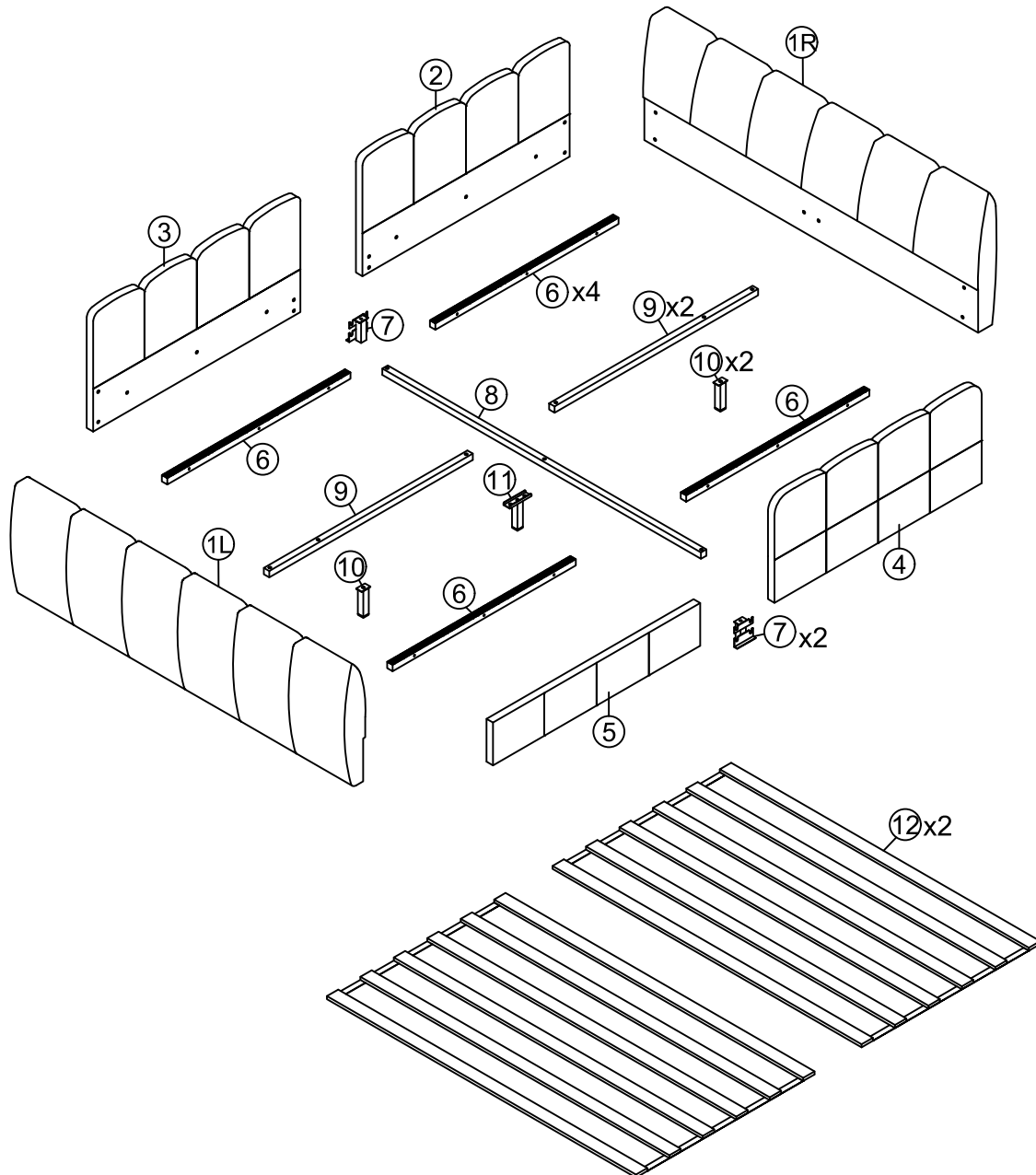

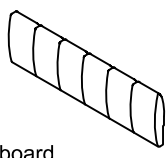
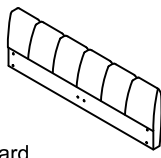
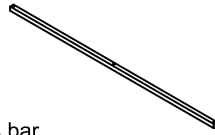
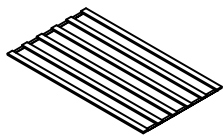

Part List

N623P460032



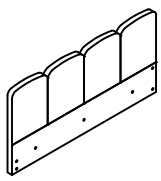
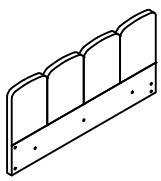
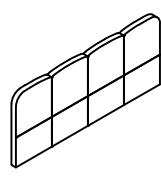
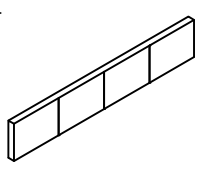
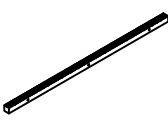
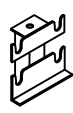
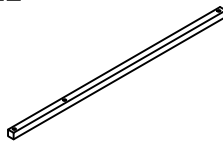
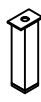

<p>①L x1</p>  <p>Foot board</p>	<p>①R x1</p>  <p>Head board</p>	<p>⑧ x1</p>  <p>Cross bar</p>	<p>⑫ x2</p>  <p>Slats</p>
--	--	---	--

N623P460033

<p>② x1</p>  <p>Siderail</p>	<p>③ x1</p>  <p>Siderail</p>	<p>④ x1</p>  <p>Siderail</p>	<p>⑤ x1</p>  <p>Siderail</p>
<p>⑥ x4</p>  <p>Side rails support bar</p>	<p>⑦ x2</p>  <p>Side rails Support legs</p>	<p>⑨ x2</p>  <p>Center support bar</p>	<p>⑩ x2</p>  <p>Middle support leg</p>
<p>⑪ x1</p>  <p>Middle support leg</p>			

Hardware list

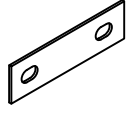
N623P460033

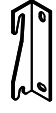
<p>Ax1</p>  <p>Allen Key</p>	<p>Bx32</p>  <p>Ø8*18mm</p> <p>Bolts</p>	<p>Cx21</p>  <p>Ø8*40mm</p> <p>Bolts</p>
<p>Dx2</p>  <p>Two hole iron</p>	<p>Ex2</p>  <p>Center support bar fittings</p>	<p>Fx4</p>  <p>Hinge</p>

DE: Vor dem Einbau die Schrauben in die Löcher stecken und festziehen, aber nicht bis 100%, 70% bis 80% anziehen reicht aus. Schließlich, nachdem alle Schrauben installiert sind, ziehen Sie alle Schrauben auf 100%.

Wenn Sie auf diese Probleme stoßen, wie z. B. Fehlausrichtung der Löcher oder Unfähigkeit, bestimmte Teile zu installieren, überprüfen Sie bitte, ob die Schrauben korrekt verwendet werden und passen Sie die Dichtigkeit der Schrauben an.

UK: Before installation, insert the screws into the holes and tighten them, but do not tighten them to 100%, 70% to 80% is sufficient. Finally, after all screws are installed, tighten all screws to 100%.

If you encounter these issues, such as if the holes cannot be aligned or some parts cannot be installed, please check if the screws are used correctly and adjust the tightness of the screws.

FR: Insérer la vis dans le trou avant la fin de l'assemblage, serrer la vis, mais ne pas serrer à 100%, 70% ~ 80% est correct. Enfin, une fois que toutes les vis sont bien serrées, toutes les vis sont serrées à 100%.

Si vous rencontrez ces problèmes, par exemple si les trous ne sont pas alignés ou si certaines pièces ne peuvent pas être montées, vérifiez que les vis sont utilisées correctement et Ajustez leur serrage.

Attention: Do not tighten the screws before completing the entire installation. If you have any difficulty with the installation process, please feel free to contact us.

Achtung: Ziehen Sie die Schrauben erst fest, wenn die gesamte Installation abgeschlossen ist. Wenn Sie beim Installationsvorgang Schwierigkeiten haben, können Sie sich gerne an uns wenden.

Attention : Ne serrez pas les vis avant d'avoir terminé l'installation. Si vous rencontrez des difficultés lors du processus d'installation, n'hésitez pas à nous contacter.



Step1:

Fix Siderail ② and ⑤ to the siderail ③ and ④ with Side rails Support legs ⑦, Two hole Iron D and Bolts B by using Allen Key A.

Befestigen Sie die Seitenleisten ② und ⑤ mit den Seitenleisten-Stützfüßen ⑦, dem zweiöchrigen Eisen D und den Schrauben B mithilfe des Inbusschlüssels A an den Seitenleisten ③ und ④.

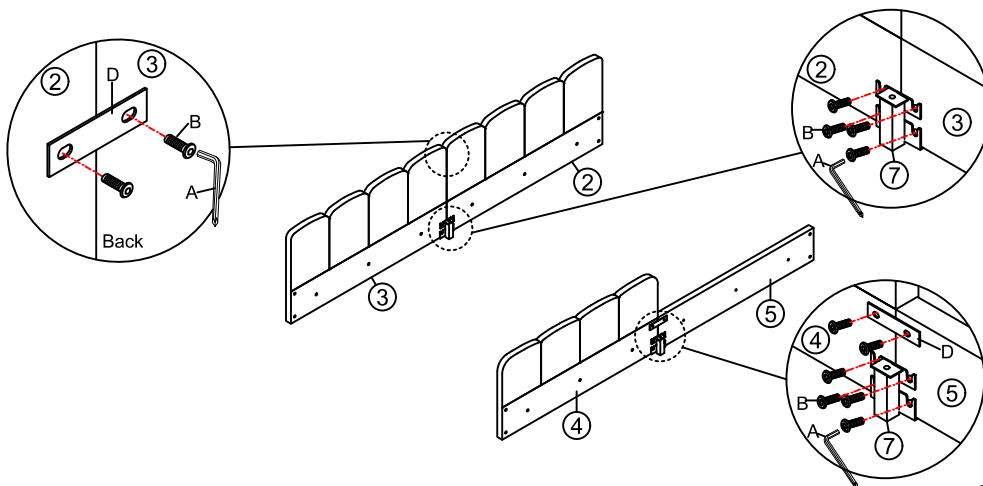
Fixez les montants latéraux ② et ⑤ aux montants latéraux ③ et ④ avec les pieds de support des montants latéraux ⑦, la tôle métallique D à deux trous et les boulons B à l'aide de la clé Allen A.



Allen Key 	B Bolts x 12  M8X18mm	D Two hole iron x2 
--	--	---



Step2:

Fix Head board ①R to the Siderail ② and ④ with Hinge F and Bolts B by using Allen Key A.

Befestigen Sie das Kopfteil ①R mit dem Scharnier F und den Schrauben B mithilfe des Inbusschlüssels A an den Seitenleisten ② und ④.

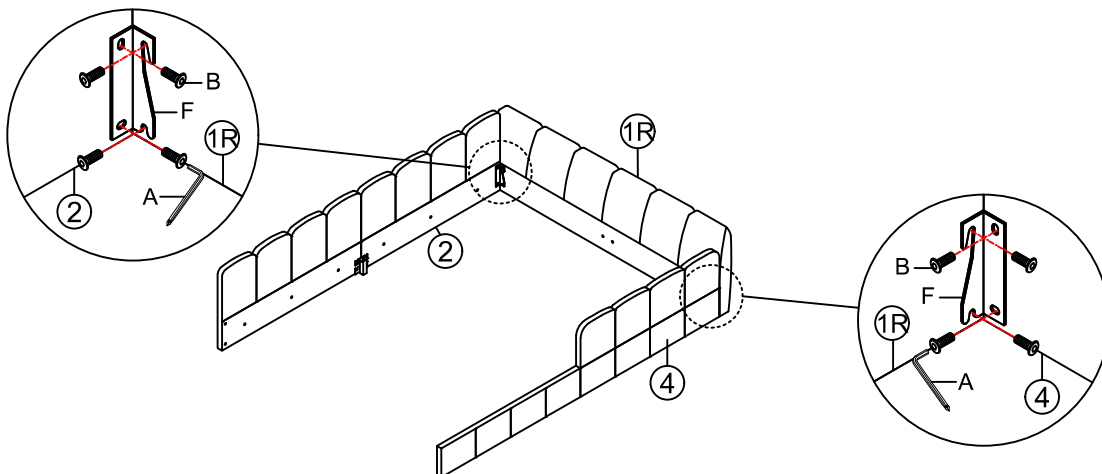
Fixez le panneau tête ①R aux montants latéraux ② et ④ avec la charnière F et les boulons B à l'aide de la clé Allen A.



Allen Key 	B Bolts x 8  M8X18mm	F Hinge x2 
--	---	---

Step 3

Fix Foot board (1)L to the Siderail (3) and (5) with Hinge F and Bolts B by using Allen Key A.

Befestigen Sie das Fußteil (1)L mit dem Scharnier F und den Schrauben B am Seitenrahmen (3) und (5) mithilfe des Inbusschlüssels A.

Fixer le pied de lit (1)L sur les montants latéraux (3) et (5) à l'aide de la charnière F, des boulons B et de la clé Allen A.

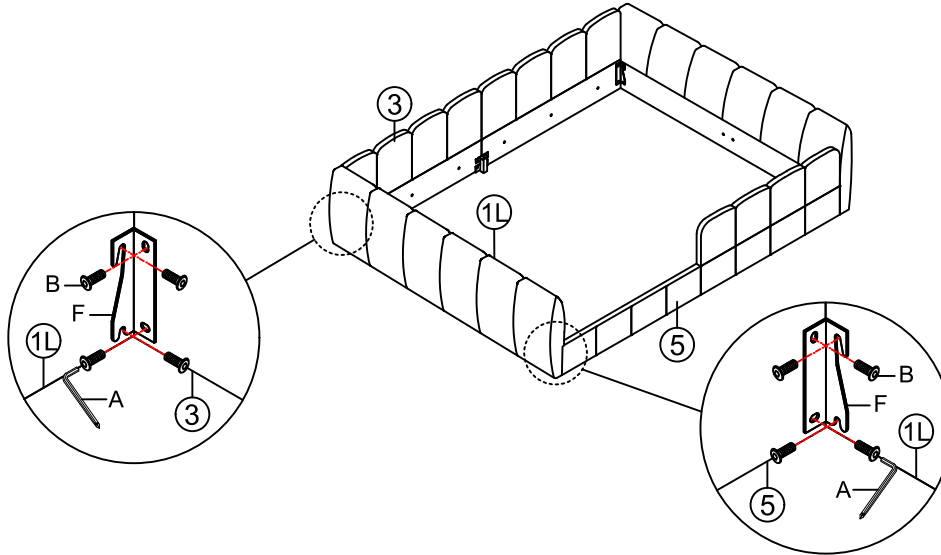

Allen Key



B Bolts x 8



M8X18mm

F Hinge x2



Step 4

Fix Side rails support bar (6) to the Siderail (2), (3), (4) and (5) with Bolts C by using Allen Key A.

Befestigen Sie die Seitenleisten-Stützstange (6) mit den Schrauben C mithilfe des Inbusschlüssels A an den Seitenleisten (2), (3), (4) und (5).

Fixez la barre de support des montants latéraux (6) aux montants latéraux (2), (3), (4) et (5) avec les boulons C à l'aide de la clé Allen A.

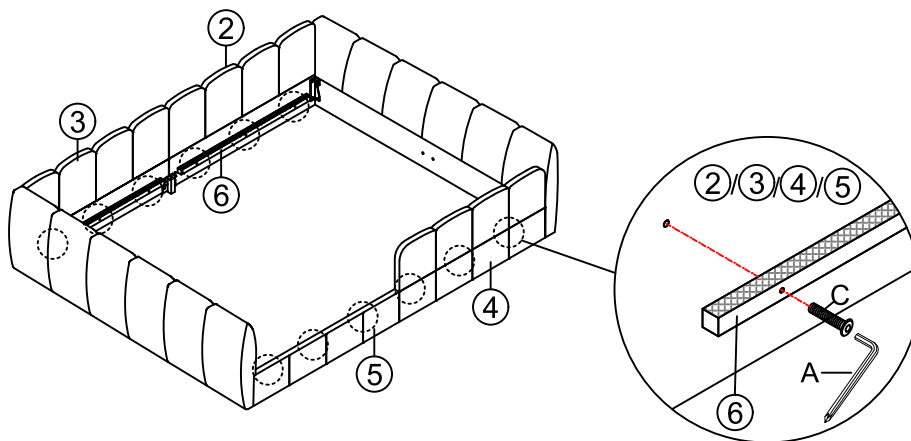

Allen Key



C Bolts x 12







M8X40mm

Step 5

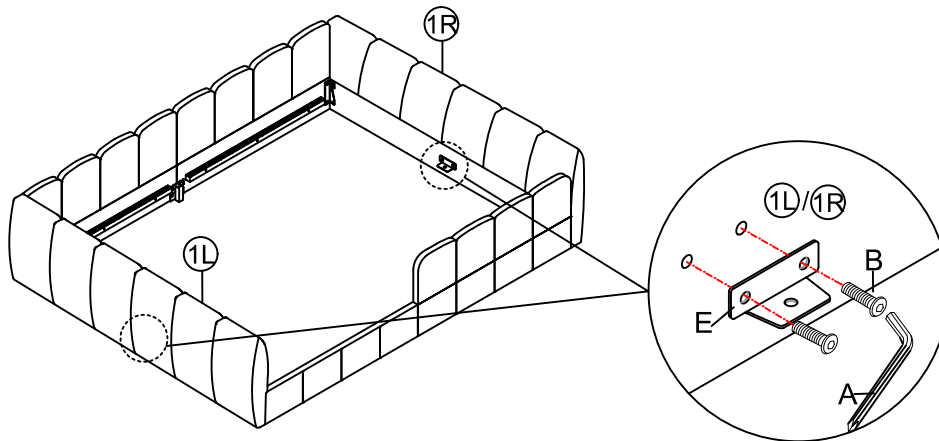
Fix the Center support bar fittings E to the Head board ①R and Foot board ①L with Bolts B by using Allen key A.
Befestigen Sie die Befestigungen der mittleren Stützstange E am Kopfteil ①R und Fußteil ①L mit Schrauben B unter Verwendung des Inbusschlüssels A.

Fixer les fixations de la barre de support centrale E sur la tête de lit ①R et le pied de lit ①L à l'aide des boulons B et de la clé Allen A.





Allen Key 	B Bolts x 4  M8X18mm	E Center support bar fittings x2 
--	---	---

Step 6

Fix the Middle support leg ⑩ and ⑪ to Center support bar ⑨ with Bolts C by using Allen key A.
Befestigen Sie die Mittelstützfüße ⑩ und ⑪ mit den Schrauben C mithilfe des Inbusschlüssels A an der Mittelstützstange ⑨.

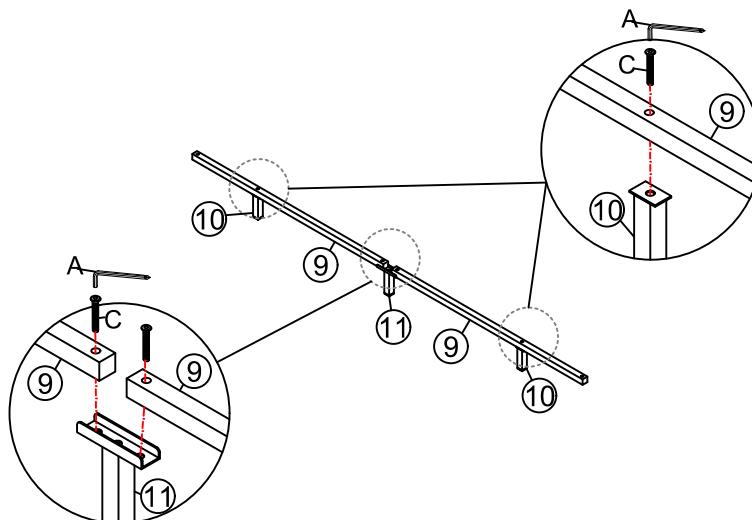
Fixez les pieds de support centraux ⑩ et ⑪ à la barre de support centrale ⑨ avec les boulons C à l'aide de la clé Allen A.



Allen Key 	C Bolts x 4  M8X40mm
--	---



Step 7

Fix Center support bar ⑨ to the Center support bar fittings E with Bolts C by using Allen Key A.

Befestigen Sie die Mittelstützstange ⑨ mit den Schrauben C mithilfe des Inbusschlüssels A an den Mittelstützstangen-Befestigungen E.

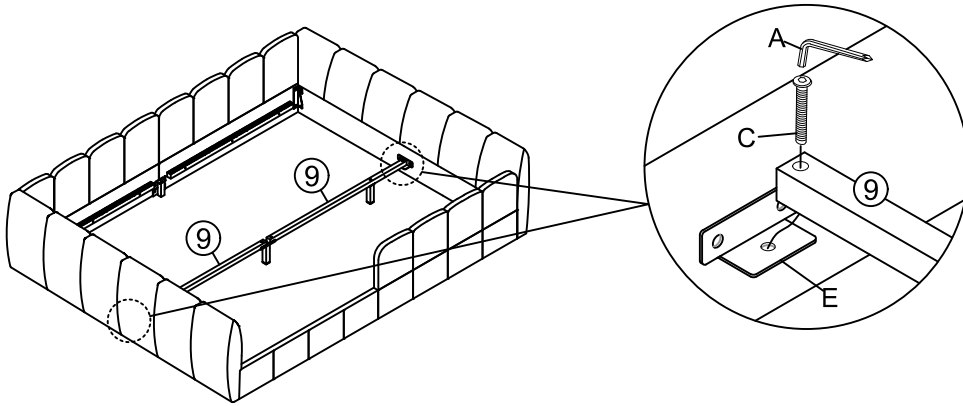
Fixez la barre de support centrale ⑨ aux fixations de la barre de support centrale E avec les boulons C à l'aide de la clé Allen A.



Allen Key 	C Bolts x 2  M8X40mm
--	---



Step 8

Fix Cross bar ⑧ to the Side rails support legs ⑦ and Middle support leg ⑪ with Bolts C by using Allen key A.

Befestigen Sie die Querstange ⑧ mit den Schrauben C mithilfe des Inbusschlüssels A an den Seitenleisten-Stützfüßen ⑦ und dem Mittelstützfuß ⑪.

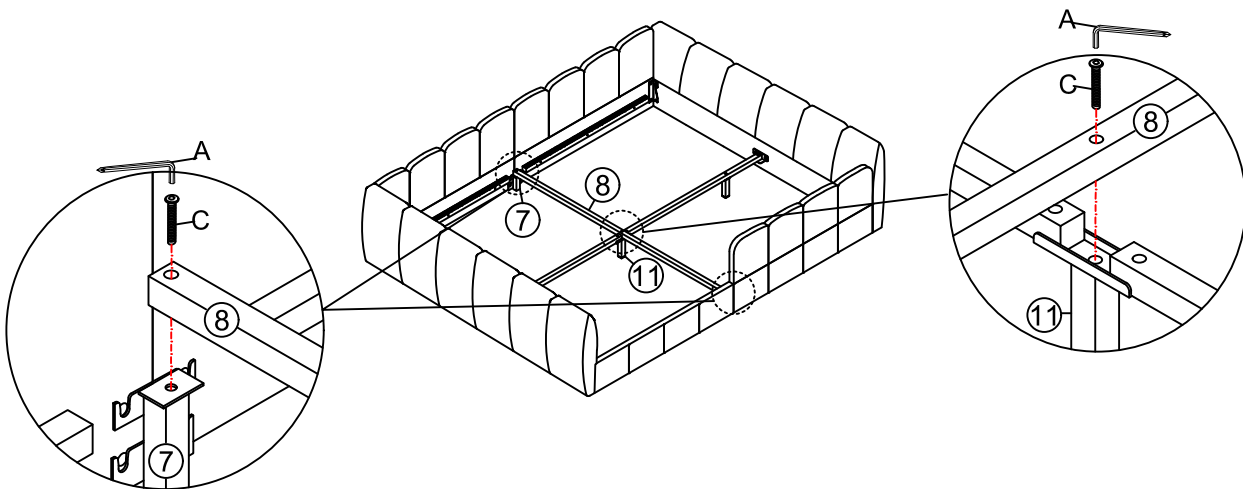
Fixez la barre transversale ⑧ aux pieds de support des montants latéraux ⑦ et au pied de support central ⑪ avec les boulons C à l'aide de la clé Allen A.



Allen Key 	C Bolts x 3  M8X40mm
--	---

Step 9

Fix the Slat ⑫ to the Side rails support bar ⑥ .

Befestigen Sie die Leiste ⑫ an der Seitenleisten-Stützstange ⑥.

Fixez la latte ⑫ sur la barre de support des montants latéraux ⑥.

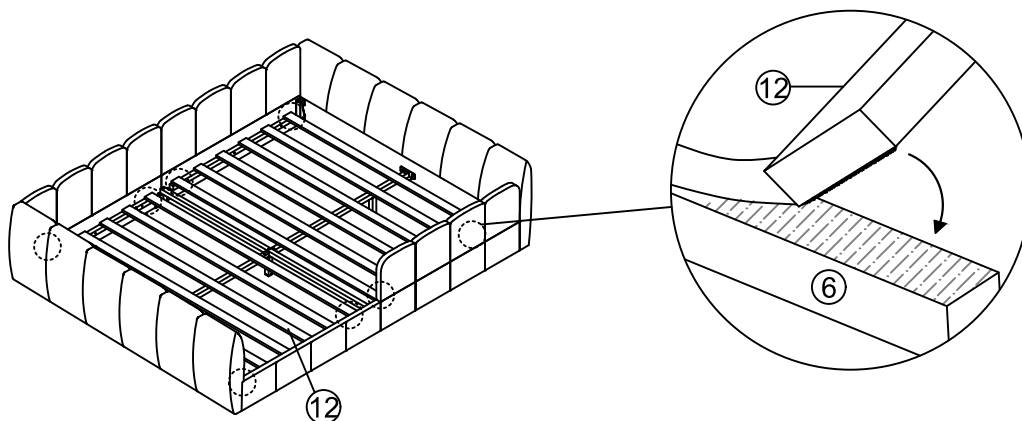

Step 10

Every thing is finished now, please enjoy your bed.

Jetzt ist alles vorbei, bitte genießen Sie Ihr Bett.

Tout est fini maintenant, profite de ton lit.

