

# Montageanleitung | Instructions de montage Assembly Instructions | Instrucciones de montaje

WF325673/WF325674

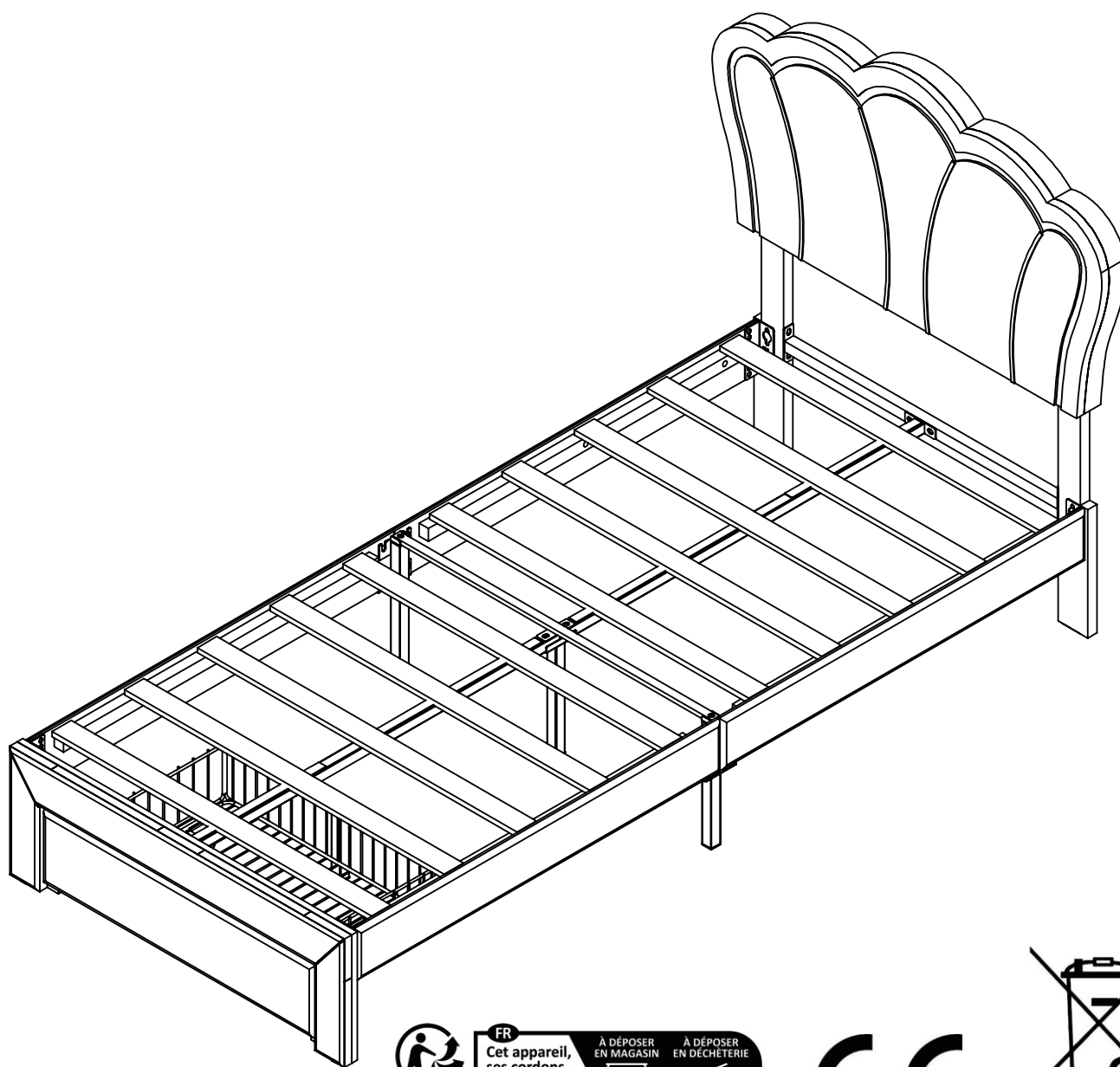

**FR**  
Cet appareil,  
ses cordons,  
et batterie  
se recyclent

À DÉPOSER  
EN MAGASIN

À DÉPOSER  
EN DÉCHÈTERIE

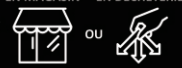

Points de collecte sur [www.quefairedemesdechets.fr](http://www.quefairedemesdechets.fr)  
Privilégiez la réparation ou le don de votre appareil !



## English

IMPORTANT ! KEEP FOR FUTURE REFERENCE : READ CAREFULLY

- To be assembled by an adult. Assembly must be checked by an adult before use
- **WARNING !** Keep all screws, small parts and plastic bags out of the reach of children
- Properly identify all parts before assembling
- Never use your item if any of its parts are broken or missing
- Should any problems arise, please contact our After Sales Service
- Manufacturer's instructions shall be followed at all times
- Care: Clean with a soft, dry cloth. In case of larger stains, carefully rub with a slightly damp, non-abrasive sponge
- Do not jump on the bed

## Français

IMPORTANT ! CONSERVER POUR RÉFÉRENCE ULTÉRIEURE : LIRE ATTENTIVEMENT

- Le montage doit être effectué par un adulte. Le montage doit être vérifié par un adulte avant utilisation
- **ATTENTION !** Tenir les vis, les petites pièces et les sachets en plastique hors de portée des enfants
- Identifiez correctement toutes les pièces avant de les assembler
- N'utilisez jamais votre article si l'une de ses pièces est cassée ou manquante
- En cas de problème, veuillez contacter notre service après-vente
- Les instructions du fabricant doivent être respectées à tout moment
- Entretien : nettoyer avec un chiffon doux et sec. En cas de taches plus importantes, frotter soigneusement avec une éponge non abrasive légèrement humide. légèrement humide et non abrasive
- Ne pas sauter sur le lit

## Deutsch

WICHTIG ! ZUM SPÄTEREN NACHSCHLAGEN AUFBEWAHREN: SORGFÄLTIG LESEN

- Muss von einem Erwachsenen zusammengebaut werden. Der Zusammenbau muss vor dem Gebrauch von einem Erwachsenen überprüft werden
- **WARNUNG!** Bewahren Sie alle Schrauben, Kleinteile und Plastikbeutel außerhalb der Reichweite von Kindern auf
- Kennzeichnen Sie vor dem Zusammenbau alle Teile richtig.
- Benutzen Sie Ihren Artikel niemals, wenn Teile gebrochen sind oder fehlen
- Sollten Probleme auftreten, wenden Sie sich bitte an unseren Kundendienst
- Die Anweisungen des Herstellers sind stets zu befolgen
- Pflege: Mit einem weichen, trockenen Tuch reinigen. Bei größeren Flecken vorsichtig mit einem leicht feuchten, nicht scheuernden Schwamm abreiben. nicht scheuernden Schwamm
- Nicht auf das Bett springen

## Italiano

**IMPORTANTE! CONSERVARE PER RIFERIMENTO FUTURO: LEGGERE ATTENTAMENTE**

- Deve essere assemblato da un adulto. L'assemblaggio deve essere controllato da un adulto prima dell'uso
- **ATTENZIONE!** Tenere tutte le viti, le piccole parti e i sacchetti di plastica fuori dalla portata dei bambini
- Identificare correttamente tutte le parti prima dell'assemblaggio
- Non utilizzare mai l'articolo se alcune parti sono rotte o mancanti
- In caso di problemi, si prega di contattare il nostro Servizio Post Vendita
- Le istruzioni del produttore devono essere sempre seguite
- Cura: Pulire con un panno morbido e asciutto. In caso di macchie più estese, strofinare accuratamente con una spugna leggermente umida e nonspugna leggermente umida e non abrasiva
- Evitare il rischio di incendio, non collocando i mobili vicino a fonti di accensione o a oggetti caldi
- Non saltare sul letto

## Español

**¡ IMPORTANTE ! CONSERVELO PARA FUTURAS CONSULTAS: LEA ATENTAMENTE**

- Debe ser montado por un adulto. El montaje debe ser comprobado por un adulto antes del uso
- ADVERTENCIA** Mantenga todos los tornillos, piezas pequeñas y bolsas de plástico fuera del alcance de los niños.
- Identifique correctamente todas las piezas antes de montarlas
  - Nunca utilice su artículo si alguna de sus piezas está rota o falta
  - Si surge algún problema, póngase en contacto con nuestro Servicio Postventa
  - Las instrucciones del fabricante deben seguirse en todo momento
  - Cuidado: Limpiar con un paño suave y seco. En caso de manchas más grandes, frote cuidadosamente con una esponja no abrasiva ligeramente humedecida.
  - Evite el riesgo de incendio no colocando los muebles cerca de fuentes de ignición u objetos calientes.
  - No saltar sobre la cama.



# 💡 More Tips 💡

## 1

English – Before installation, you can place the parts on a carpet or other soft fabric, in order to avoid damaging your floor.

Français – Avant l'installation, vous pouvez placer les pièces sur un tapis ou un autre tissu doux, afin d'éviter d'endommager votre sol.

Deutsch – Vor der Installation können Sie die Teile auf einen Teppich oder ein anderes weiches Material legen, um eine Beschädigung Ihres Fußbodens zu vermeiden.

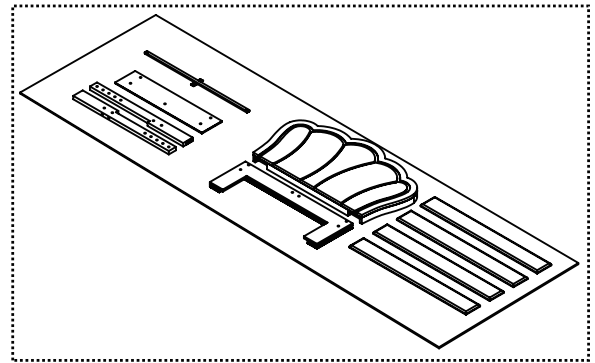
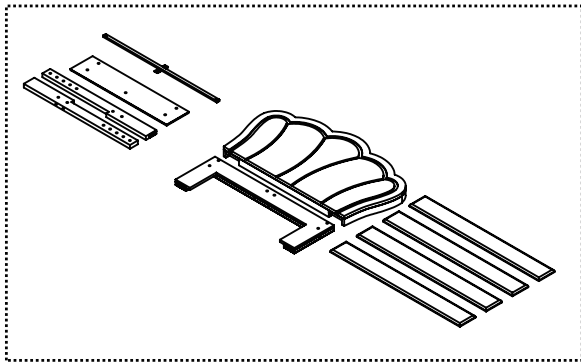

## 2

English – For your and your family's safety, please do not jump on beds, especially with hydraulic structures. When need to move bed, please work with more than one person to lift, not push, to avoid scratching your floor and hurting the stability of the bed.





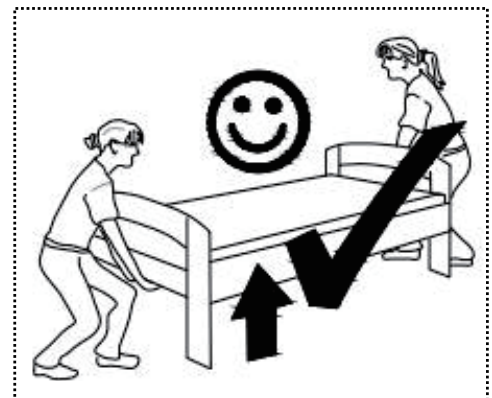
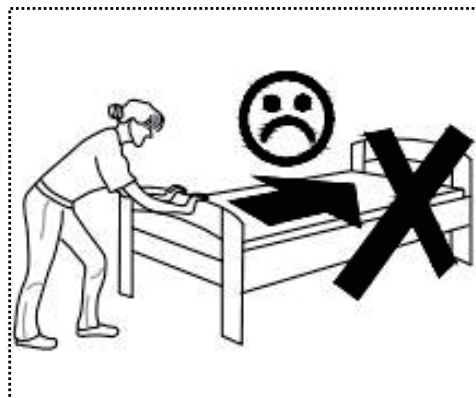

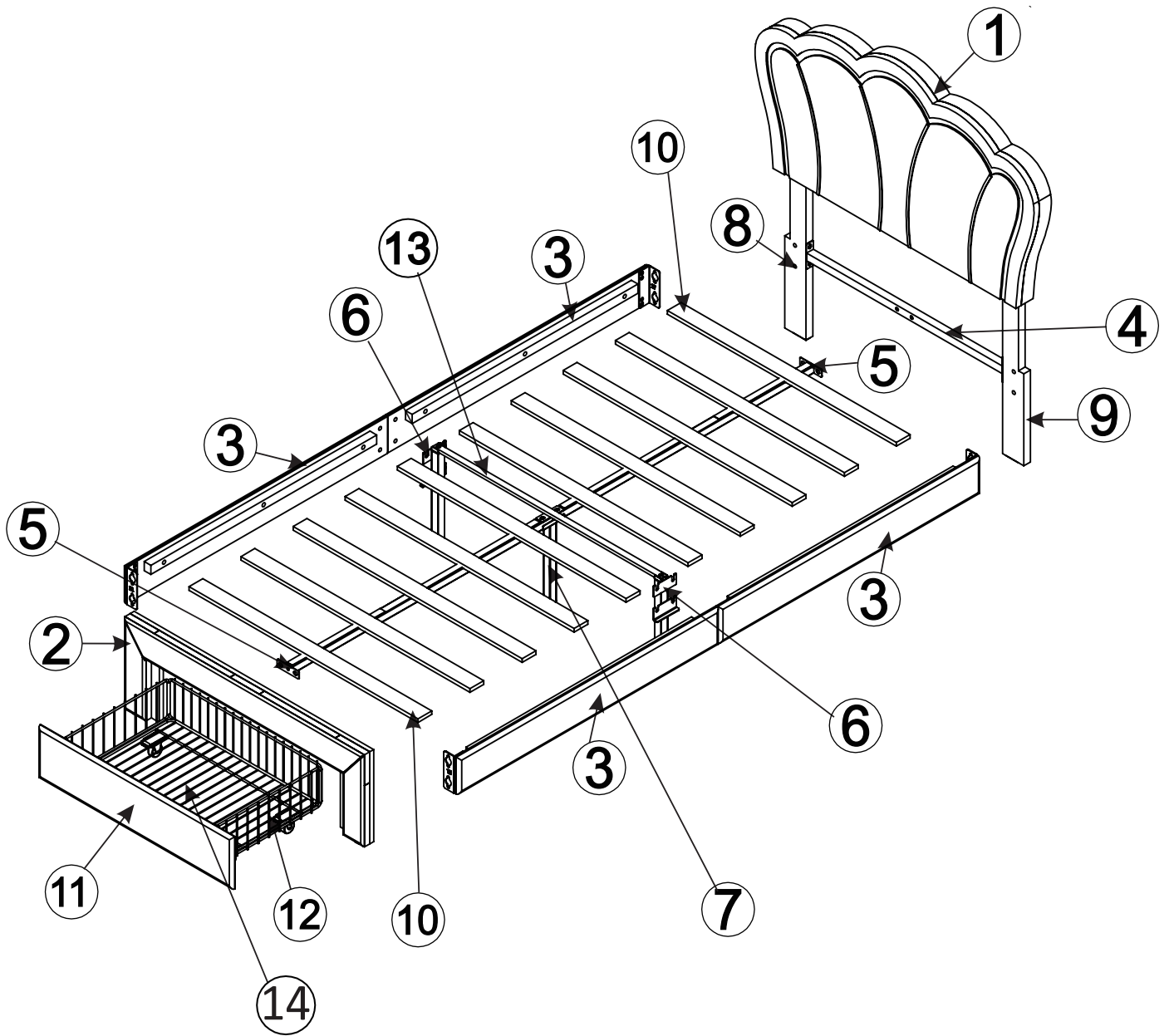

Français – Pour votre sécurité et celle de votre famille, ne sautez pas sur les lits, en particulier sur les structures hydrauliques. Lorsqu'il est nécessaire de déplacer le lit, il est préférable de travailler à plusieurs pour le soulever, et non pour le pousser, afin d'éviter de rayer le sol et de nuire à la stabilité du lit.

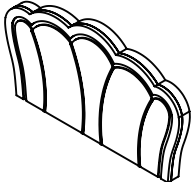
Deutsch – Zu Ihrer Sicherheit und der Ihrer Familie sollten Sie nicht auf Betten springen, insbesondere bei hydraulischen Konstruktionen. Wenn Sie das Bett bewegen müssen, heben Sie es bitte mit mehreren Personen an und schieben Sie es nicht, um den Boden nicht zu verkratzen und die Stabilität des Bettes nicht zu beeinträchtigen.

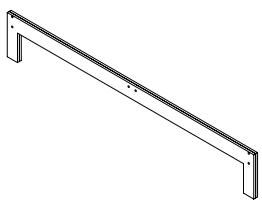

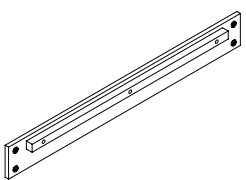
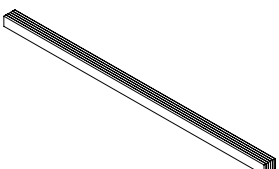
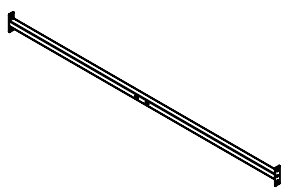
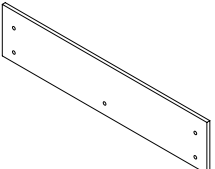
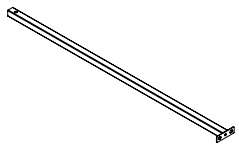

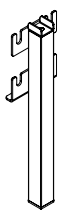

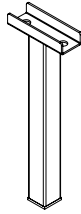
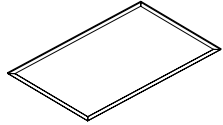



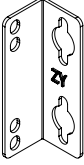

# WF325673/WF325674

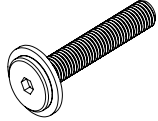
<b>1</b>		X1	<b>8</b>		X1
<b>2</b>		X1	<b>9</b>		X1
<b>3</b>		X4	<b>10</b>		X2
<b>4</b>		X1	<b>11</b>		X1
<b>5</b>		X2	<b>12</b>		X1
<b>6</b>		X2	<b>13</b>		X1
<b>7</b>		X1	<b>14</b>		X1

# Hardware List –Hardware Liste-Liste dumatériel

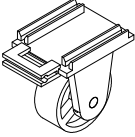
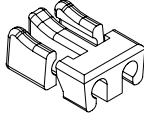
WF325673/WF325674

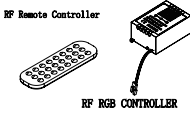
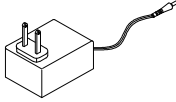
<p><b>A</b></p>		<p>4pcs</p>	<p><b>B</b></p>	 <p>M8*25mm</p>	<p>11PCS</p>	<p><b>C</b></p>	 <p>M8*40 mm</p>	<p>11PCS</p>
<p><b>D</b></p>	 <p>M8*14mm</p>	<p>5PCS</p>	<p><b>E</b></p>	 <p>S5</p>	<p>1PC</p>	<p><b>H</b></p>		<p>1PC</p>
<p><b>L</b></p>		<p>4pcs</p>	<p><b>R</b></p>		<p>2PCS</p>	<p><b>I</b></p>	 <p>ST 3x12</p>	<p>2PCS</p>
	 <p>RF Remote Controller RF RGB CONTROLLER</p>	<p>1PC</p>		<p>Adaptor</p> 	<p>1PC</p>			

1



M8\*40  
C x 4pcs

S5



x 1pc

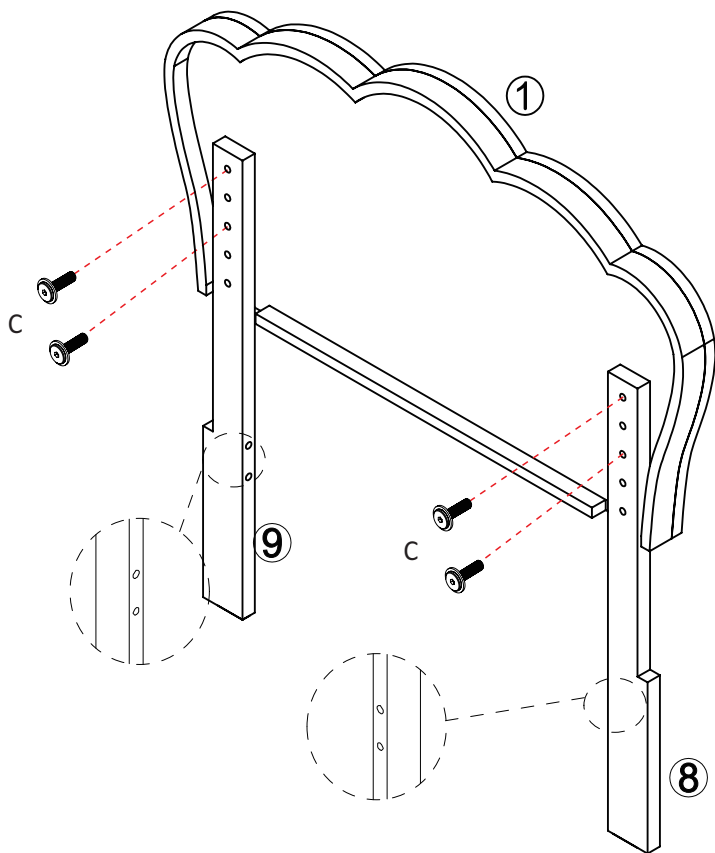

Headboard height is adjustable  
Die Höhe des Kopfteils ist verstellbar

La hauteur de la tête de lit est réglable  
L'altezza della testiera è regolabile  
Cabecera ajustable en altura

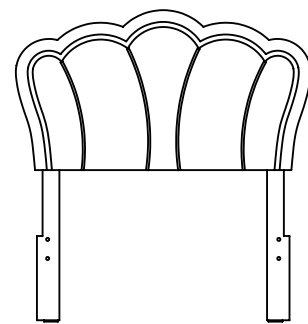

2



M8\*25  
B x 4pcs

S5

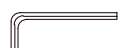

x 1pc

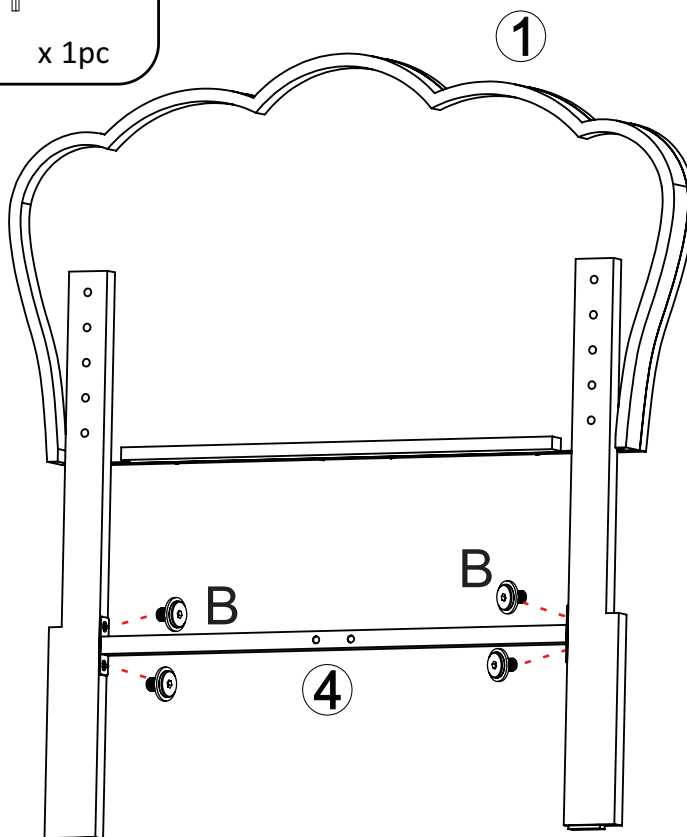

2



A x 4pcs

S5



x 1pc

Desserrer les boulons  
Serrez les supports en L sur

Schrauben lösen  
Ziehen Sie die L-Bügel an

Untighten the bolts  
Tighten the L-brackets on

In caso di rottura della vite  
con bullonatura a l

Afloje los tornillos para  
tensar los pernos l

X2

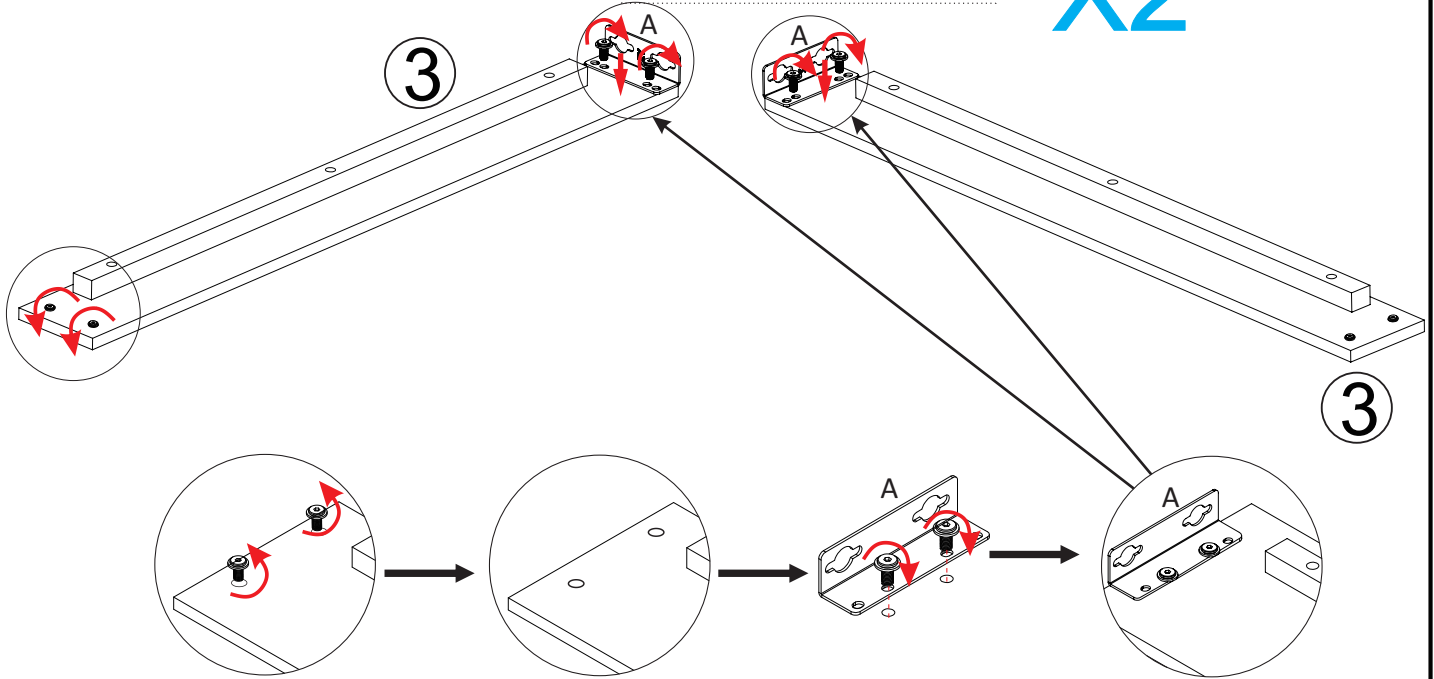

3

S5

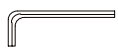

x 1pc

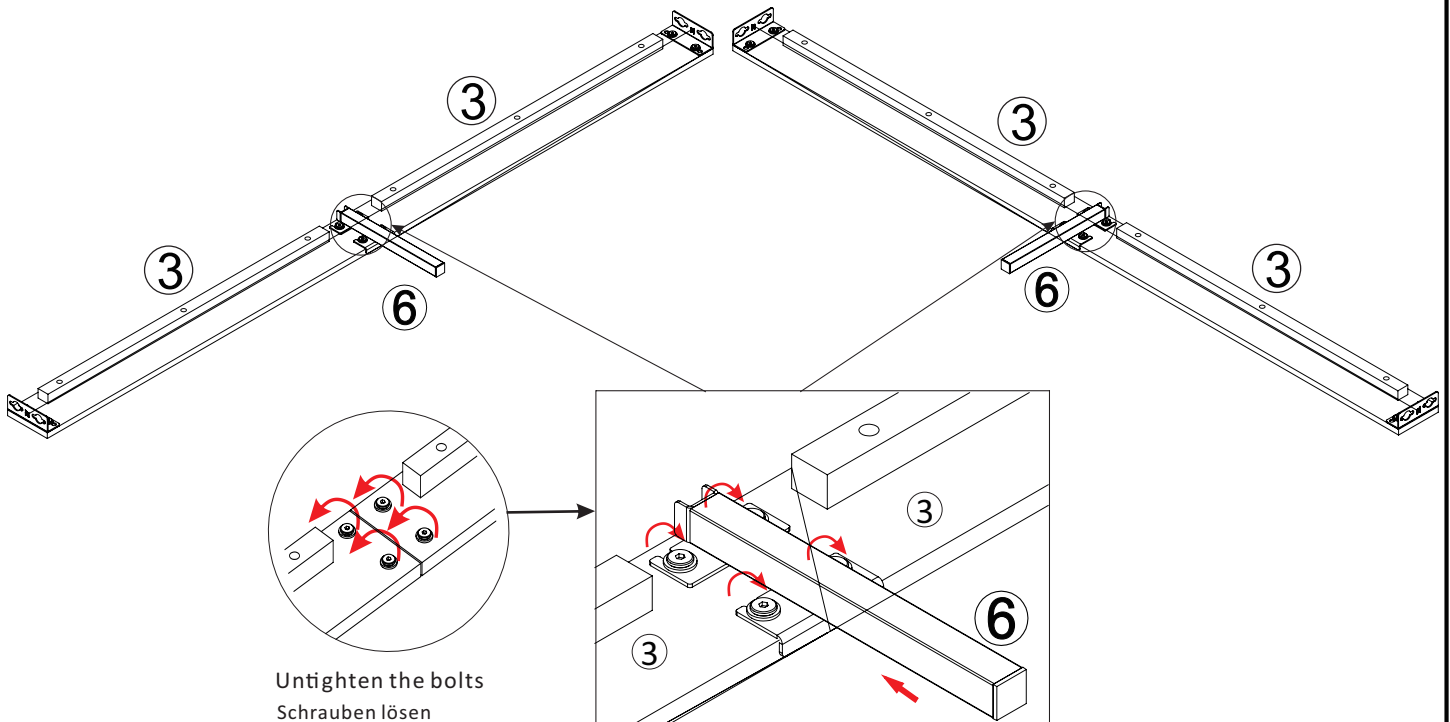

Untighten the bolts  
Schrauben lösen  
Desserrer les boulons  
Soluzione di filo  
atornillar

4

S5



x 1pc

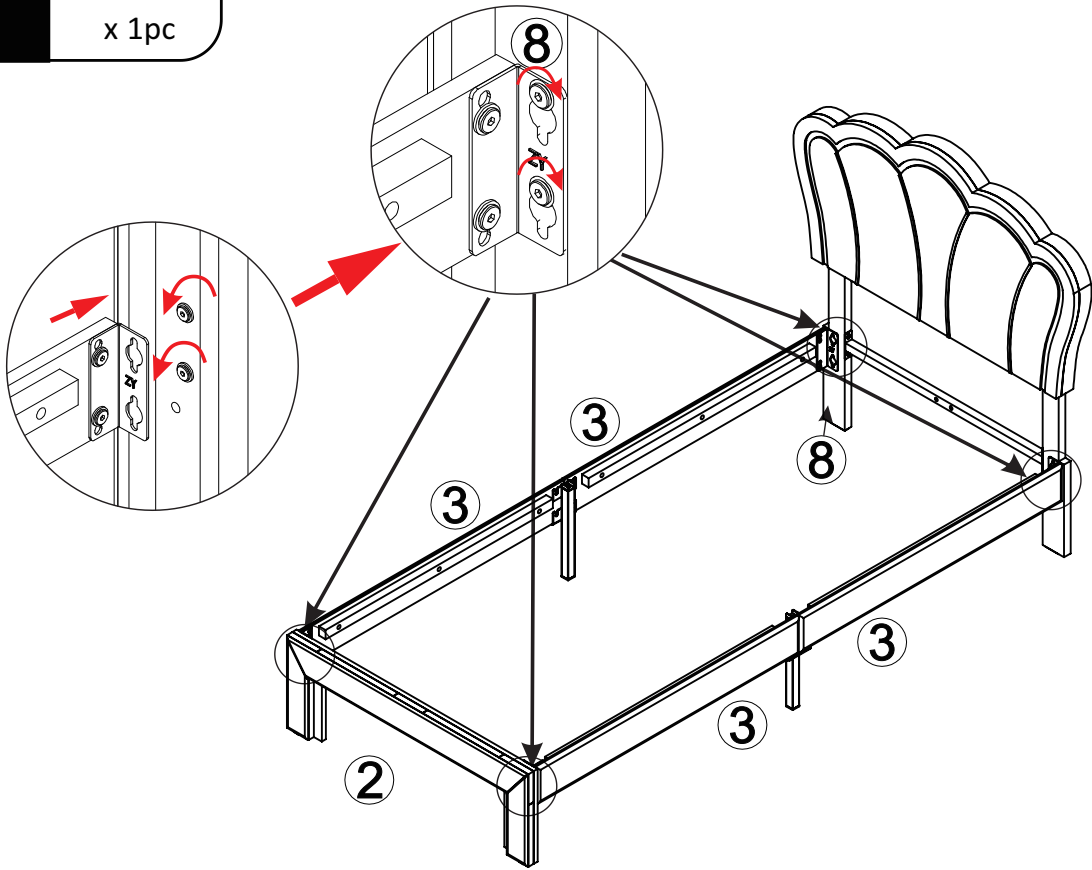

5



M8\*25  
B x 4pcs

S5



x 1pc

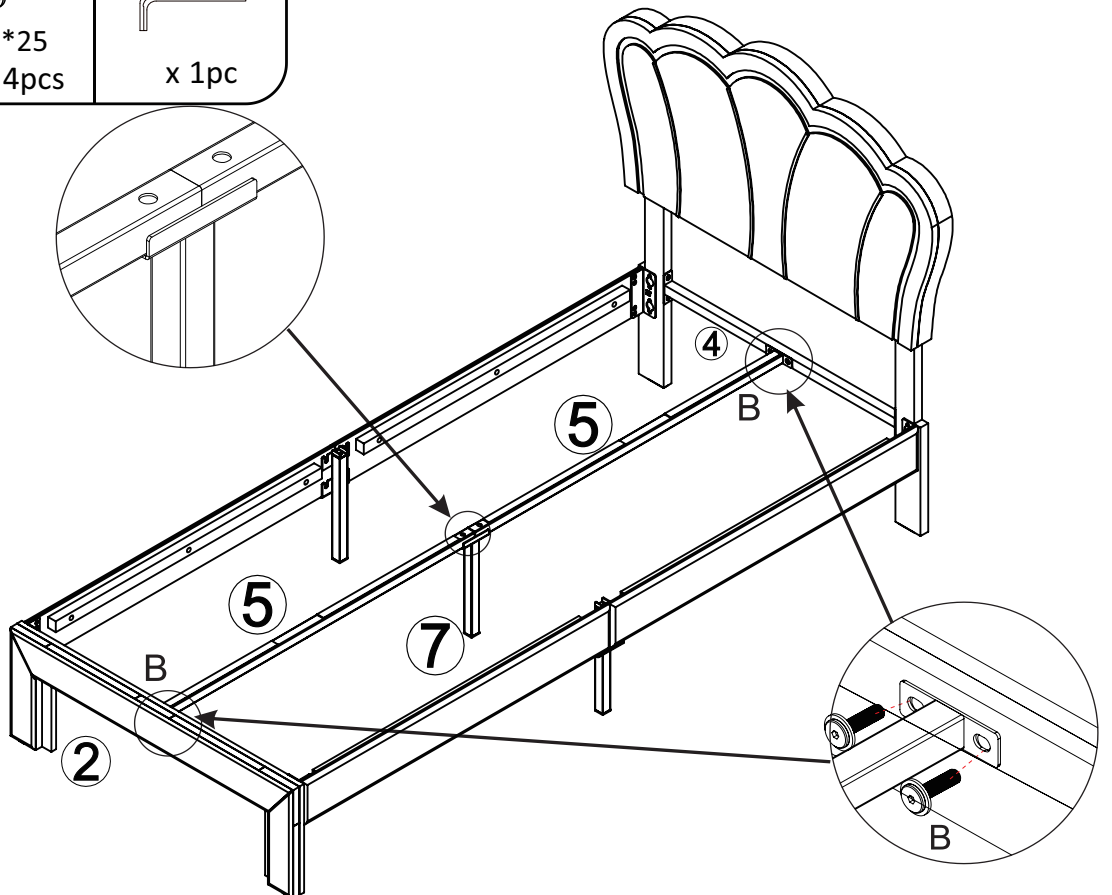

6



M8\*25  
B x 2pcs



M8\*40  
C x 2pcs

S5



x 1pc

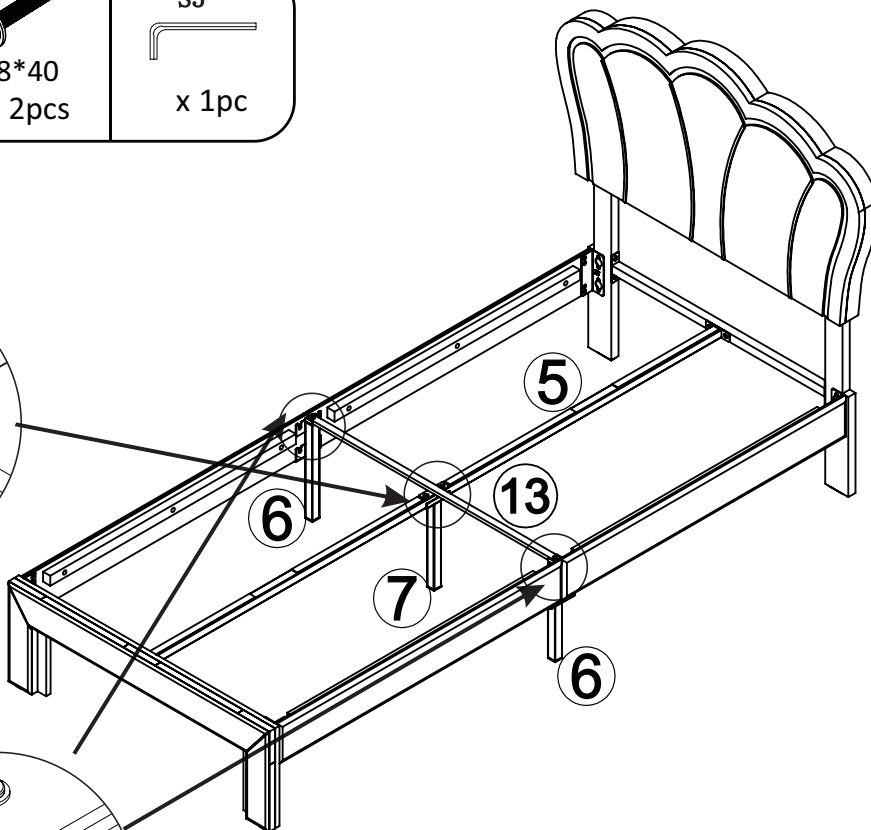
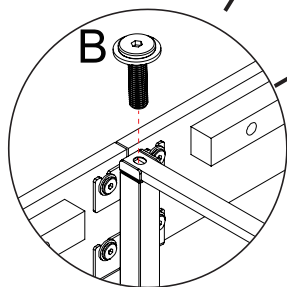
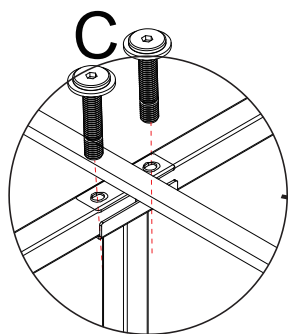

7

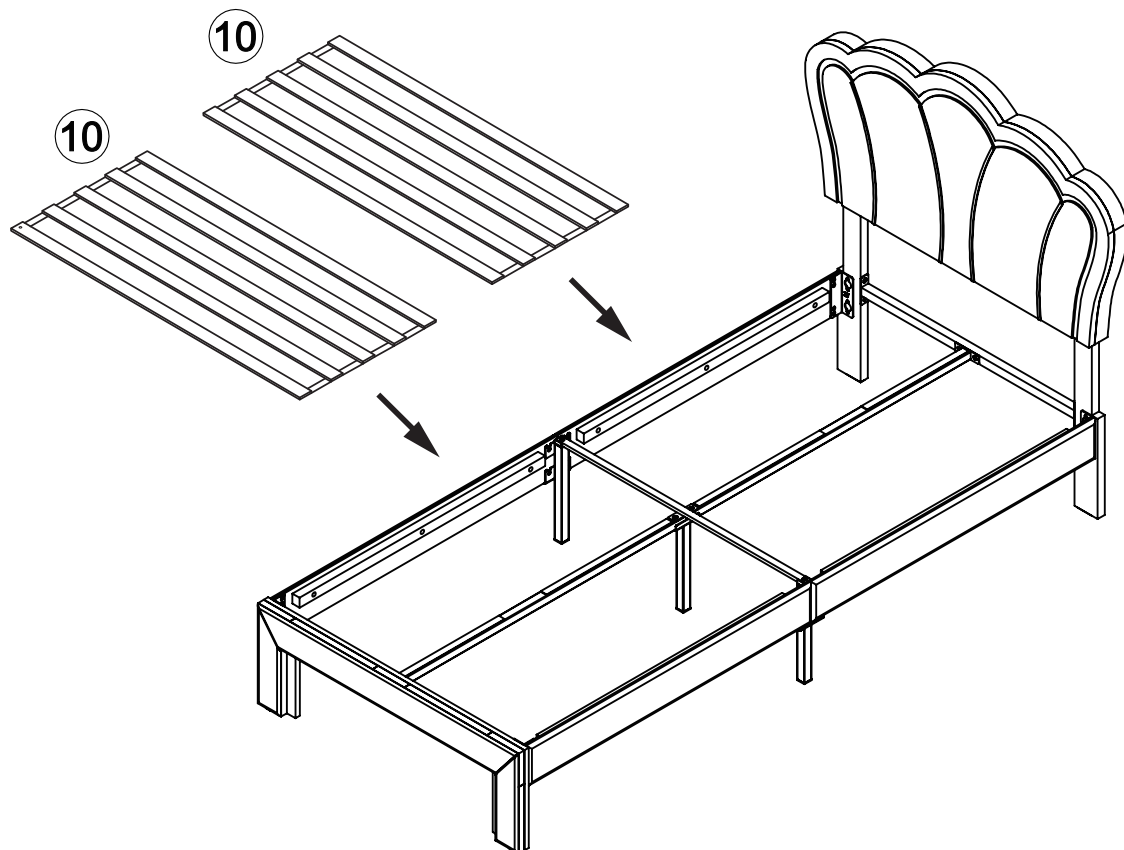

8

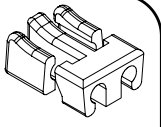

R x 2PCS

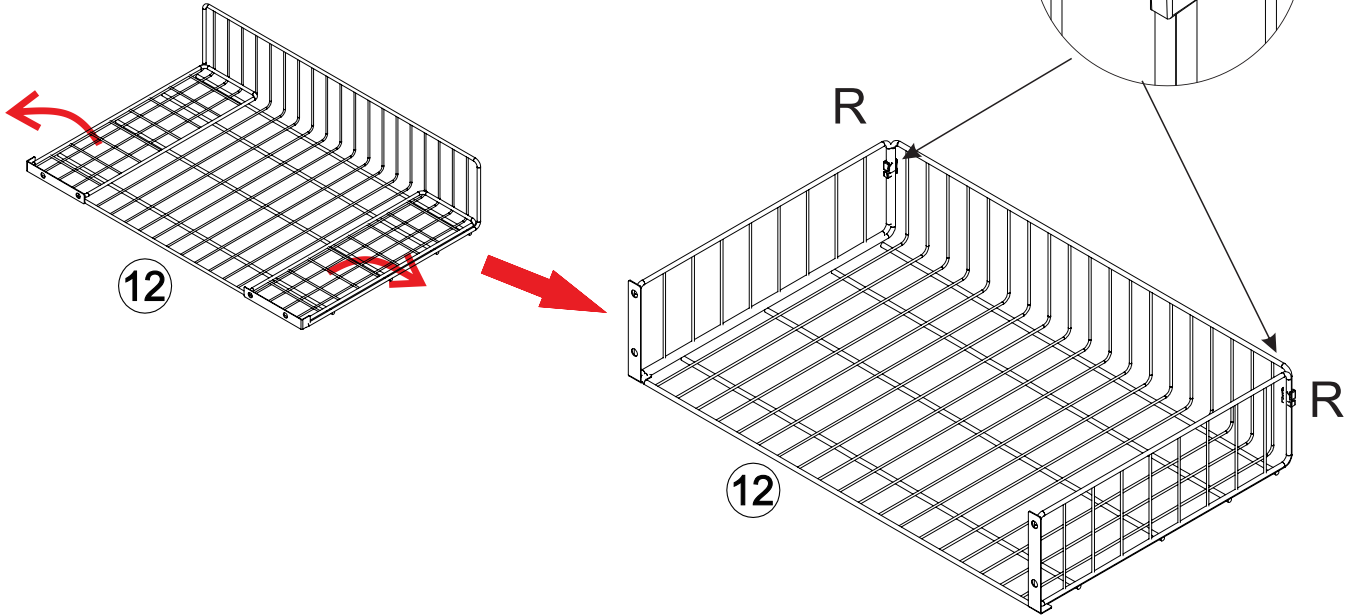

9



L x 4pcs



H x 1pc

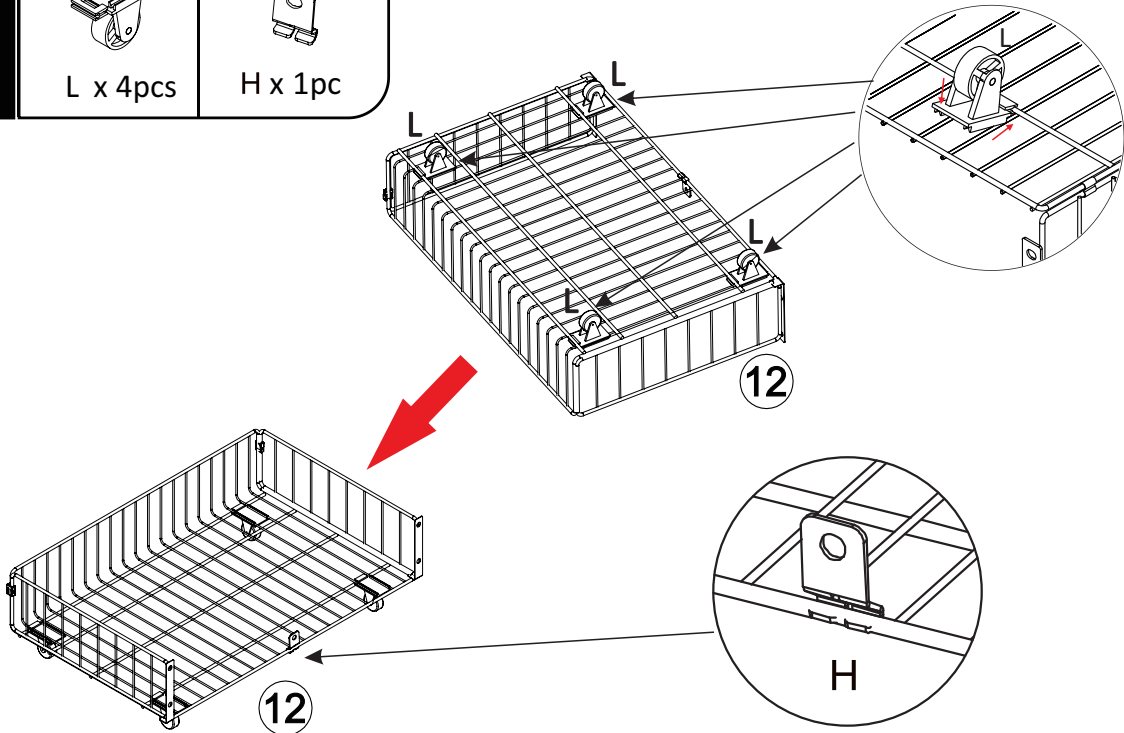

10

M8\*14mm  
D x 5pcs

S5  
x 1pc



pay attention to the direction of the buckle  
Achten Sie auf die Richtung der Schnalle  
Faites attention à la direction de la boucle

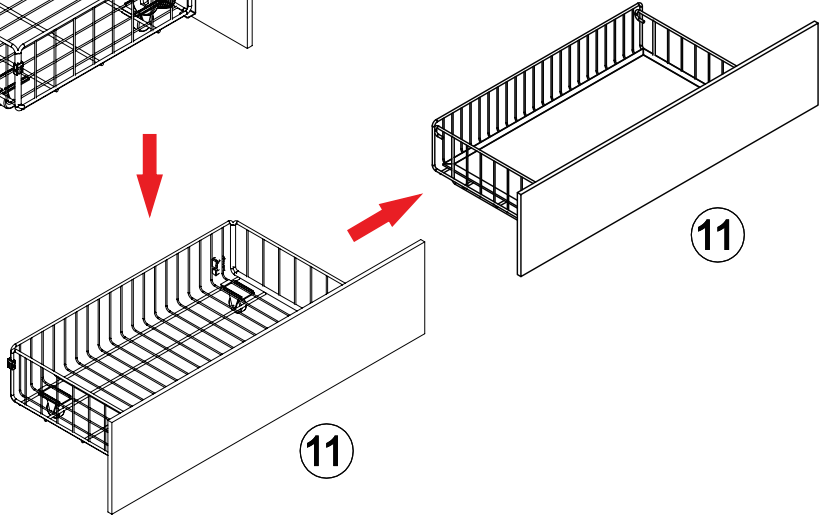
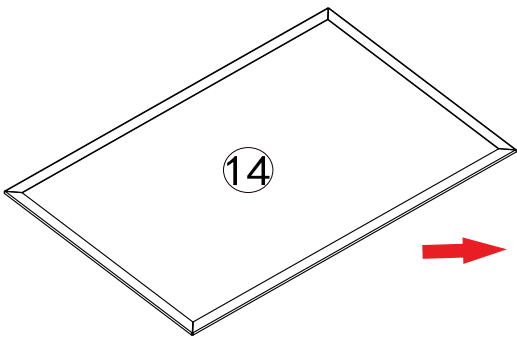
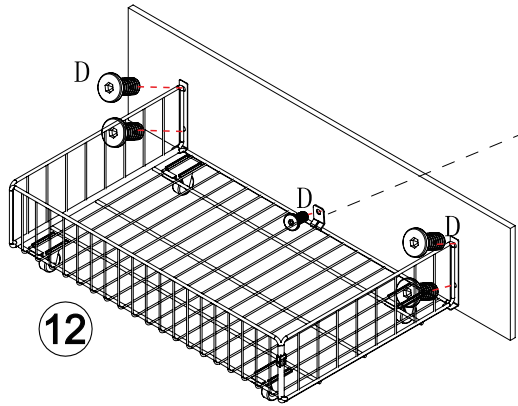
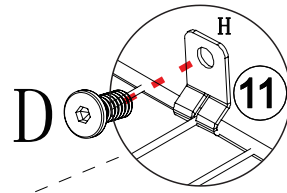

11

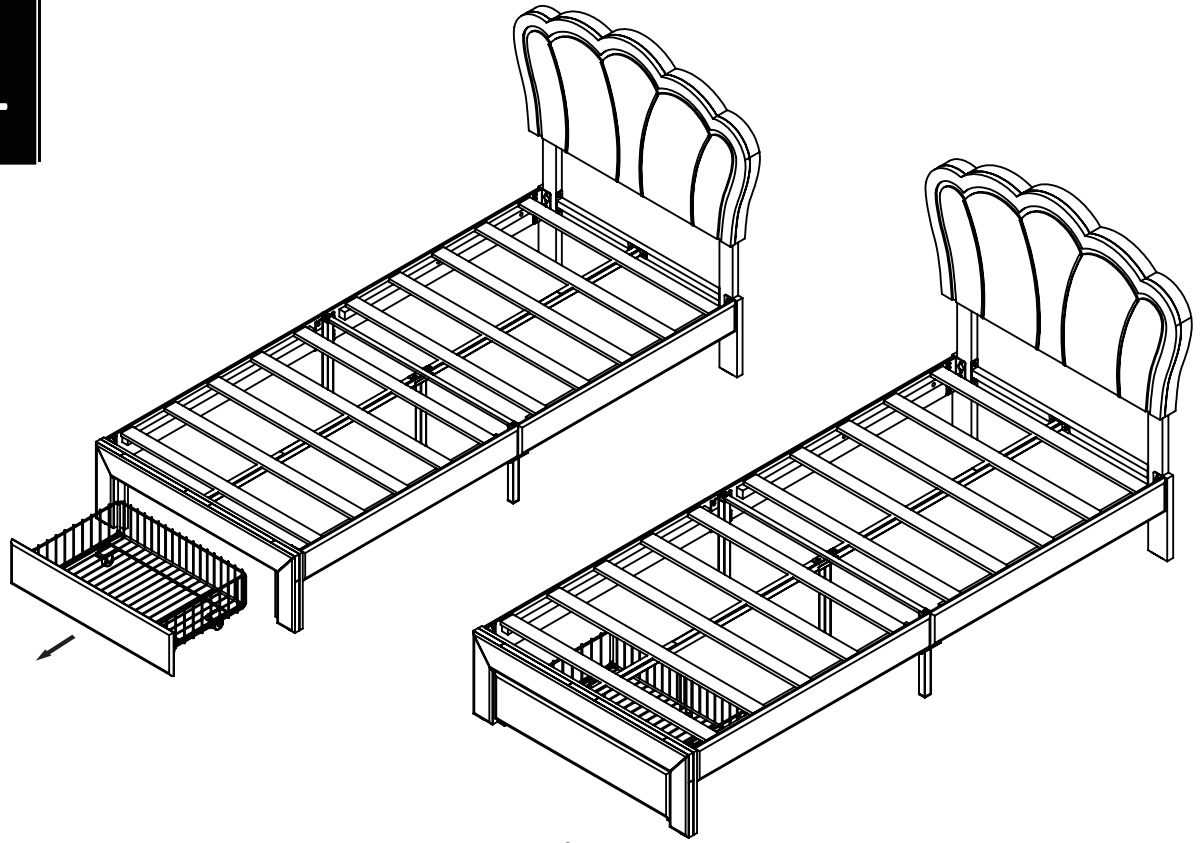

12



ST 3x12  
1 x 2pcs

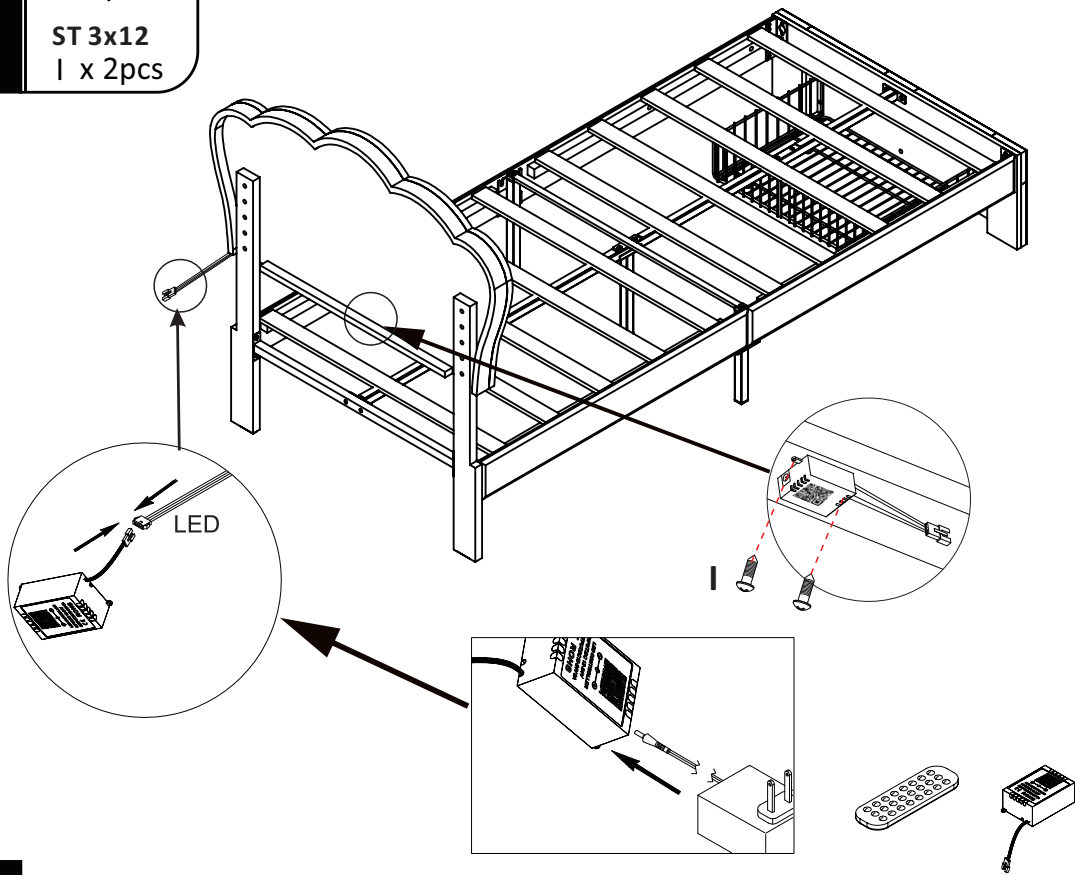

13

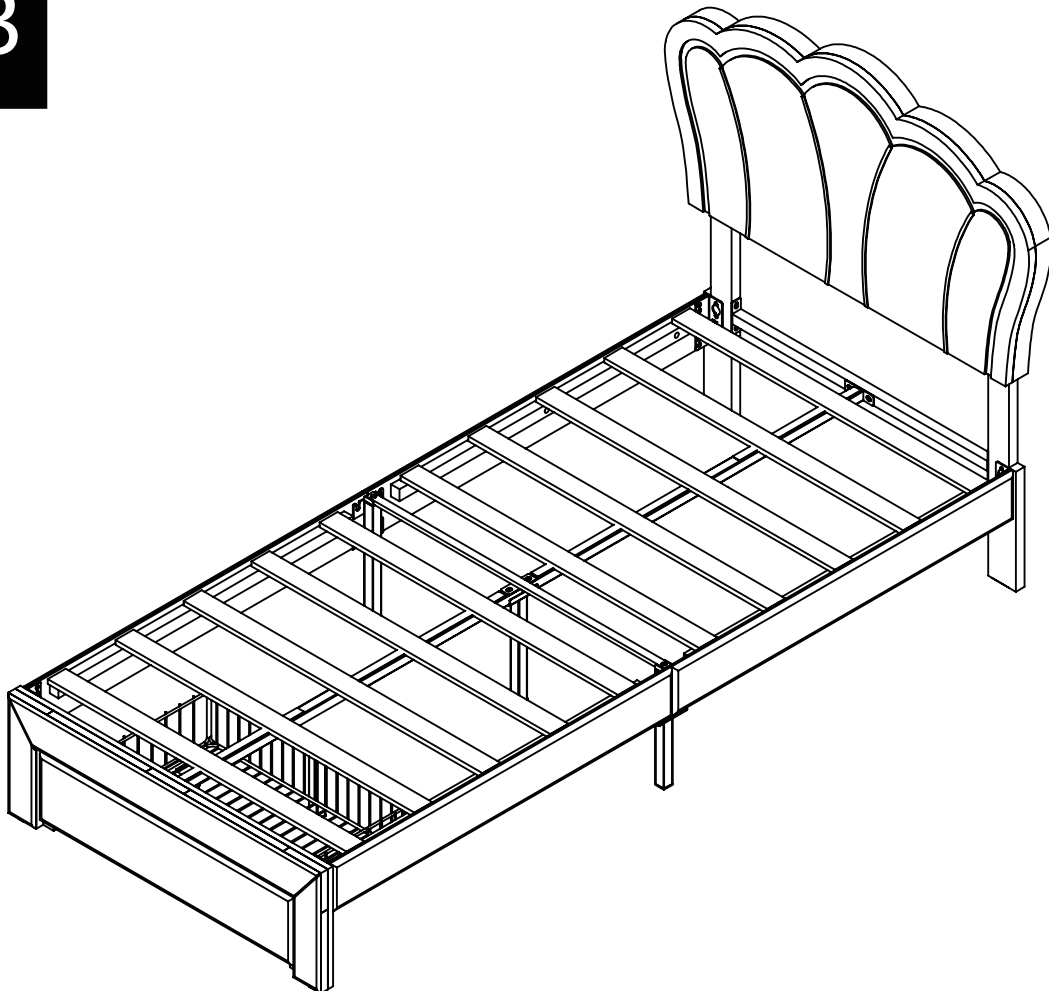

## EN:Battery Safety Instructions

1. Do not dispose of used button batteries or remote controls in household trash. To protect the environment and prevent hazardous leakage, please follow these guidelines:
2. Remove button batteries after use and take them to a local battery recycling point or hazardous waste collection site.
3. Do not burn or dismantle the batteries to avoid explosion or toxic release.
4. If the remote control is no longer in use, please deliver it to a certified electronics recycling facility to promote resource reuse.
5. Keep out of reach of children to prevent accidental ingestion or injury.
6. This product does not include batteries; please purchase them separately. The compatible button cell model for the remote control is CR2025 3V.
7. If the light strip is not working, please try replacing the battery first. If the issue persists, contact the seller for assistance.
8. **Keep the remote control away from children — keep it away from children!** If the battery is accidentally swallowed, seek medical attention immediately.

## DE:Batteriesicherheitshinweise

1. Entsorgen Sie gebrauchte Knopfzellen oder Fernbedienungen nicht im Hausmüll. Um die Umwelt zu schützen und gefährliche Leckagen zu vermeiden, beachten Sie bitte die folgenden Hinweise:
2. Entfernen Sie die Knopfzelle nach dem Gebrauch und bringen Sie sie zu einer örtlichen Batteriesammelstelle oder einem Sondermüllentsorgungszentrum.
3. Batterien nicht verbrennen oder zerlegen, um Explosionen oder die Freisetzung giftiger Stoffe zu vermeiden.
4. Wenn die Fernbedienung nicht mehr verwendet wird, bringen Sie sie zu einer zertifizierten Elektronik-Recyclingstelle, um eine Wiederverwertung zu ermöglichen.
5. Außerhalb der Reichweite von Kindern aufbewahren, um versehentliches Verschlucken oder Verletzungen zu verhindern.
6. Dieses Produkt enthält keine Batterien. Bitte kaufen Sie diese separat. Das kompatible Knopfzellenmodell für die Fernbedienung ist CR2025, 3V.
7. Wenn der Lichtstreifen nicht funktioniert, versuchen Sie zunächst, die Batterie zu wechseln. Besteht das Problem weiterhin, kontaktieren Sie bitte den Verkäufer.
8. **Halten Sie die Fernbedienung unbedingt von Kindern fern — unbedingt fernhalten!** Wird die Batterie versehentlich verschluckt, suchen Sie sofort medizinische Hilfe auf.

## FR:Instructions de sécurité pour les piles

1. Ne jetez pas les piles bouton usagées ou les télécommandes à la poubelle ménagère. Pour protéger l' environnement et éviter tout risque de fuite dangereuse, veuillez suivre les consignes suivantes :
  2. Retirez les piles bouton après usage et déposez-les dans un point de collecte local ou un centre de déchets dangereux.
  3. Ne brûlez pas et ne démontez pas les piles, cela pourrait entraîner une explosion ou libérer des substances toxiques.
  4. Si la télécommande n'est plus utilisée, déposez-la dans un centre de recyclage agréé pour appareils électroniques, afin de favoriser la réutilisation des ressources.
  5. Gardez hors de portée des enfants pour éviter tout risque d'ingestion accidentelle ou de blessure.
- 6.Ce produit ne contient pas de pile. Veuillez l'acheter séparément. Le modèle de pile bouton compatible pour la télécommande est CR2025, 3V.
- 7.Si le ruban LED ne fonctionne pas, essayez d'abord de remplacer la pile. Si le problème persiste, contactez le vendeur.
- 8.**Tenez la télécommande éloignée des enfants — éloignez-la vraiment !** En cas d'ingestion accidentelle de la pile, consultez immédiatement un médecin.

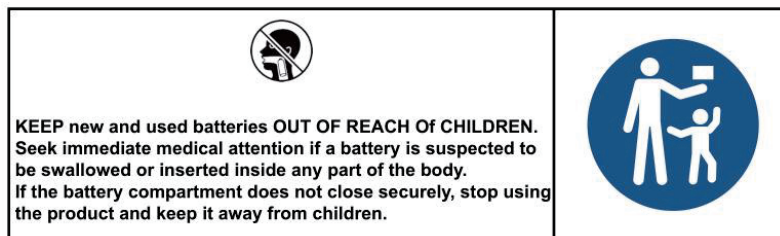

If a battery has been ingested, or there is a possibility one might have been ingested, please seek medical attention and inform the medical authorities that you suspect battery ingestion.

It's not always clear when a child has swallowed a button battery, as there are no specific symptoms. However, they might:

- cough, gag, or drool;
- seem to have a stomach bug or virus;
- vomit;
- complain of pain in their stomach, chest, or throat;
- appear tired or sluggish; and
- lose their appetite.

Since the signs aren't obvious, it's important to keep a close eye on loose, used, or spare button batteries in your home, as well as the products that contain them.

## You can choose mobile control or RF Remote Control

First, pull out the plastic card on the RF Remote Controller and power on the RF Remote Controller.

Mobile phone control steps:

1. Connect LED Lamp and RF RGB Controller.
2. Plug in the Adaptor Power supply.
3. Scan the RF RGB Controller QR code on the controller and download the software .
4. Turn on the Bluetooth function of the mobile phone and search for Bluetooth pairing .
5. Open the LED APP and switch colors change.  
Click the music switch to realize the skip mode of different LED lights.  
Press the timing switch to realize the automatic light o ffunction,etc.

Sie haben die Wahl zwischen mobiler Steuerung oder RF Remote Control

Ziehen Sie zunächst die Plastikkarte auf der RF-Fernbedienung heraus und schalten Sie die RF-Fernbedienung ein.

Schritte zur Steuerung des Mobiltelefons:

1. LED-Lampe und RF-RGB-Controller anschließen.
2. Schließen Sie das Netzteil des Adapters an.
3. Scannen Sie den QR-Code des RF RGB Controllers auf dem Controller und laden Sie die Software herunter.
4. Schalten Sie die Bluetooth-Funktion des Mobiltelefons ein und suchen Sie nach Bluetooth-Kopplung .
5. Öffnen Sie die LED-APP und wechseln Sie die Schalterfarben.

Klicken Sie auf den Musikschalter, um den Skip-Modus verschiedener LED-Leuchten zu aktivieren.

Drücken Sie den Zeitschalter, um die automatische Lichtfunktion usw. zu realisieren.

## Vous pouvez choisir le contrôle mobile ou le contrôle à distance RF

Tout d'abord, retirez la carte plastique de la télécommande RF et allumez la télécommande RF.

Étapes de contrôle du téléphone portable :

1. Connectez la lampe LED et le contrôleur RF RGB.
2. Branchez l'adaptateur d'alimentation.
3. Scannez le code QR du contrôleur RF RGB sur le contrôleur et téléchargez le logiciel.
4. Activez la fonction Bluetooth du téléphone portable et recherchez l'appairage Bluetooth .
5. Ouvrez l'application LED et changez de couleur.

Cliquez sur le commutateur de musique pour réaliser le mode de saut de différentes lumières LED.

Appuyez sur le commutateur de temporisation pour réaliser la lumière automatique o ffunction, etc.



GB- NOTE: The battery in the remote control requires you to purchase and install it yourself.  
Model: CR2025 3.V

DE-HINWEIS: Die Batterie in der Fernbedienung müssen Sie selbst kaufen und installieren.  
Modell: CR2025 3.V

FR-REMARQUE : la pile de la télécommande doit être achetée et installée par vos soins.  
Modèle: CR2025 3.V

IT-NOTA: la batteria del telecomando deve essere acquistata e installata autonomamente.  
Modell: CR2025 3.V

ES-NOTA: La pila del mando a distancia debe comprarla e instalarla usted mismo.  
Modelo CR2025 3.V

①



②



③



④



⑤



⑥



⑦



⑧



# CERTIFICATE

## of Conformity

### Low Voltage Directive (EU) 2014/35

**Registration No.:** AN 50619202 0001  
**Report No.:** CN23HD4Y 001  
**Holder:** Xiamen Eahunt Electronics Co.,Ltd.  
Room 755, Venture Building,  
Venture Park, Torch High-tech Zone,  
Xiamen,  
Fujian  
P.R. China  
**Product:** Power Supply  
(SWITCHING POWER SUPPLY)

#### Type designation listed on the next page

This certificate of conformity is based on an evaluation of a sample of the above-mentioned product. Technical Report and documentation are at the License Holder's disposal. This is to certify that the tested sample is in conformity with Annex I of Council Directive (EU) 2014/35, referred to as the Low Voltage Directive. This certificate does not imply assessment of the series-production of the product and does not permit the use of a TÜV Rheinland mark of conformity. The holder of the certificate is authorized to use this certificate in connection with the EC declaration of conformity according to Annex IV of the Directive.

**Date:** 2024-02-02

**Certification Body**



Dipl.-Ing. Th. Illing



**TÜV Rheinland LGA Products GmbH - Tillystraße 2 - 90431 Nürnberg**

CE The CE marking may be used if all relevant and effective EC Directives/Regulations are complied with. CE

[www.tuv.com](http://www.tuv.com)

 **TÜVRheinland®**  
Precisely Right.

**DE:** Wenn Sie die Lichter nicht erfolgreich arbeiten lassen können, überprüfen Sie bitte die Folgendes:

1. Bitte überprüfen Sie die Fernbedienung. Sie müssen die Fernbedienung abreißen Plastikseptum vor Gebrauch.
2. Lassen Sie die Fernbedienung nicht zu weit vom Empfänger entfernt sein Es gibt kein Hindernis zwischen ihnen.
3. Bitte beachten Sie, dass die Fernbedienung für den Transport keine Batterien enthält. Das Batteriemodell lautet: CR2025

**FR:** Si vous ne parvenez pas à faire fonctionner les lumières correctement, veuillez vérifier les points suivants :

1. Veuillez vérifier la télécommande. Vous devez retirer le septum en plastique de la télécommande avant utilisation.
2. Ne laissez pas la télécommande être trop éloignée du récepteur. Il n'y a aucun obstacle entre eux.
3. Veuillez noter que la télécommande ne contient pas de piles pour le transport. Le modèle de batterie est : CR2025

**UK:** If you can't make the lights work successfully, please check the following:

1. Please check the remote control. You need to tear off the remote plastic septum before use.
2. Don't let the remote control be too far from the receiver There is no obstacle between them.
3. Please note that the remote control does not contain batteries for transportation. The battery model is: CR2025



# Certificate of Conformity

Certification Number: :ZTL21ER-052406EZ

Zhiyuan Testing(Shenzhen) Co. Ltd. hereby declares that testing has been completed and reports have been generated for:

Applicant: Shenzhen Kingunion Lighting Co., LTD  
Address: Second Floor, No.1 Kaixinda Technology Park, No 49th Zhoushi Road, Langxin Community, Shiyan Town, Baoan District, Shenzhen City, Guangdong, China

Manufacturer: Shenzhen Kingunion Lighting Co., LTD  
Address: Second Floor, No.1 Kaixinda Technology Park, No 49th Zhoushi Road, Langxin Community, Shiyan Town, Baoan District, Shenzhen City, Guangdong, China

Product: LED Strip

Trademark: 

Model: KU-5050-60D-RGB

Rating: DC12V  
EN 55015:2019+A11:2020

Test standard: EN 61547:2009  
EN 61000-3-2:2019  
EN 61000-3-3:2013AMD.1:2019

The EUT described above has been consolidate by us and found in compliance with the council EMC (as amended) -- 2014/30/EU. It is only valid in connection with the report number:ZTL21ER-052406EZ.



This certificate of conformity is based on a single evaluation of the submitted sample(s) of the above mentioned product. It does not imply an assessment of the whole product and relevant Directives have to be observed.

Address: Room 505A, 5th Floor, R&D Center Building, Hongfa Jatei High-tech Park,  
Langxin Community, Shiyan Street, Baoan District, Shenzhen, China  
Tel: +86-755-21002030 Fax: +86-755-21002030 <http://www.sz-ztl.cn/>



Certification Number: :ZTL21ER-052406EZ

## Model accessories:

**KU-\*\*\*\*-XXX-YY-ZZ-Series-12V**

**Remarks:**KU represents abbreviation of company name; \*\*\*\* represents led model of product; XXX represents led quantity of product; YY represents length of product; ZZ represents waterproof type of product: A=IP20, B=IP44, C=IP65, D=IP66, E=IP67, F=IP68; Series is product series, represents different color, RGB represents three colors.

KU-5050-16D-RGB	KU-5050-18D-RGB	KU-5050-24D-RGB	KU-5050-30D-RGB
KU-3528-16D-RGB	KU-3528-18D-RGB	KU-3528-24D-RGB	KU-3528-30D-RGB
KU-2835-16D-RGB	KU-2835-18D-RGB	KU-2835-24D-RGB	KU-2835-30D-RGB
KU-3535-12D-RGB	KU-3535-18D-RGB	KU-3535-24D-RGB	KU-3535-30D-RGB
KU-3838-12D-RGB	KU-3838-18D-RGB	KU-3838-24D-RGB	KU-3838-30D-RGB
KU-4040-12D-RGB	KU-4040-18D-RGB	KU-4040-24D-RGB	KU-4040-30D-RGB
KU-5050-36D-RGB	KU-5050-42D-RGB	KU-5050-48D-RGB	KU-5050-60D-RGB
KU-3528-36D-RGB	KU-3528-42D-RGB	KU-3528-48D-RGB	KU-3528-60D-RGB
KU-2835-36D-RGB	KU-2835-42D-RGB	KU-2835-48D-RGB	KU-2835-60D-RGB
KU-3535-36D-RGB	KU-3535-42D-RGB	KU-3535-48D-RGB	KU-3535-60D-RGB
KU-3838-36D-RGB	KU-3838-42D-RGB	KU-3838-48D-RGB	KU-3838-60D-RGB
KU-4040-36D-RGB	KU-4040-42D-RGB	KU-4040-48D-RGB	KU-4040-60D-RGB
KU-5050-72D-RGB	KU-5050-84D-RGB	KU-5050-96D-RGB	KU-5050-120D-RGB
KU-3528-72D-RGB	KU-3528-84D-RGB	KU-3528-96D-RGB	KU-3528-120D-RGB
KU-2835-72D-RGB	KU-2835-84D-RGB	KU-2835-96D-RGB	KU-2835-120D-RGB
KU-3535-72D-RGB	KU-3535-84D-RGB	KU-3535-96D-RGB	KU-3535-120D-RGB
KU-3838-72D-RGB	KU-3838-84D-RGB	KU-3838-96D-RGB	KU-3838-120D-RGB
KU-4040-72D-RGB	KU-4040-84D-RGB	KU-4040-96D-RGB	KU-4040-120D-RGB
KU-3535-RGB	KU-2835-RGB	KU-3528-RGB	KU-5050-RGB
KU-3838-RGB	KU-4040-RGB		

Address:Room 505A, 5th Floor, R&D Center Building, Hongfa Jateli High-tech Park,  
Langxin Community, Shiyan Street, Baoan District, Shenzhen, China

Tel:+86-755-21002030

Fax:+86-755-21002030

<http://www.sz-ztl.cn/>



Importeur	Decobus Handel GmbH
Adresse	Innungsstraße 9,21244 Buchholz,Deutschland
Email/URL	<a href="https://www.decobusgroup.de">https://www.decobusgroup.de</a>
Hersteller	Shenzhen Kingunion Lighting Co., LTD
Adresse	Second Floor, No.1 Kaixinda Technology Park, No 49th Zhonshi Road,Langxin Community, Shiyan Town, Baoan District, Shenzhen City,Guangdong, China
Email/URL	<a href="https://www.sz-ztl.cn">https://www.sz-ztl.cn</a>
Partienumm	202505
Hergestellt in	China



Produkt:LED soft light strip Model:KU-5050-60D-RGB
Nennspannung:5 V Nennfrequenz: 50/60Hz Leistung: 4.5W/M



Decobus Handel GmbH  
Innungsstraße 9,21244 Buchholz,Deutschland  
<https://www.decobusgroup.de>

Importeur	Decobus Handel GmbH
Adresse	Innungsstraße 9,21244 Buchholz,Deutschland
Email/URL	<a href="https://www.decobusgroup.de">https://www.decobusgroup.de</a>
Hersteller	Dongguan Yihong Hardware electronics Co., LTD
Adresse	Room 1106,NO.2 Shangheng Road,Chang'an Town Dongguan, Guangdong,523880 China
Email/URL	<a href="https://www.ptc-testing.com">https://www.ptc-testing.com</a>
Partienumm	202505
Hergestellt in	China



Produkt:2.4G Remote Controller Model:YH-629,JH-40....
Nennspannung:5 V Nennfrequenz: 50/60Hz Leistung: 4.5W/M



Decobus Handel GmbH  
Innungsstraße 9,21244 Buchholz,Deutschland  
<https://www.decobusgroup.de>