

Montageanleitung | Instructions de montage Assembly Instructions | Instrucciones de montaje

V20260130

SKU NUMBER: N616P418295
N616P418296
N616P418297
N616P418298

90x200cm

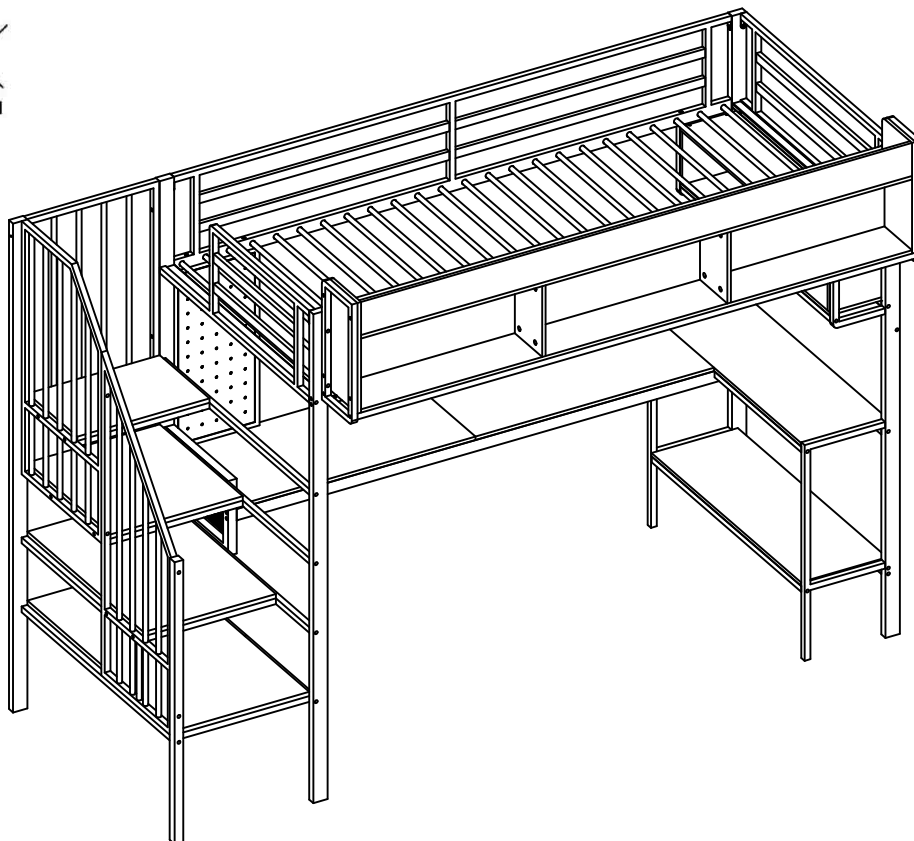

This set comes in 4 boxes. If you do not receive a full set of 4 boxes, please contact our customer service.

Dieses Set wird in 4 Schachteln geliefert. Wenn Sie nicht ein komplettes Set von 4 Boxen erhalten, kontaktieren Sie bitte unseren Kundenservice.

Ce set est livré en 4 boîtes. Si vous ne recevez pas un jeu complet de 4 boîtes, veuillez contacter notre service clientèle.

IMPORTANT- READ CAREFULLY-

RETAIN FOR FUTURE REFERENCE

TOP TIPS BEFORE YOU START !

1. Please check that all parts & hardware are present before you start the assembly of your furniture.
2. For ease and speed of assembly, we recommend that before you commence each step of the assembly,

Please identify all the parts required for that step.
3. We recommend that where possible, all items are assembled near to the area in which they will be placed in use,

to avoid moving the product unnecessarily once assembled.
4. For the protection of your furniture, particularly items of high gloss finish, we recommend that the product is placed on a

Protected surface during assembly to prevent any damage.
5. During assembly please take care not to over-tighten any fittings, as this may damage the product.

CARE AND MAINTENANCE OF YOUR FURNITURE

1. Please periodically check all fittings and re-tighten as necessary.
2. To clean your item, please use a damp cloth and wipe clean.
3. Never allow any kind of liquid to remain on your furniture. Absorption can cause wood to warp or finishes to de-laminate.
4. Please do not place hot items (e.g hot drinks) directly on the wood surface.
5. Please do not drag or pull your furniture.

IMPORTANT INFORMATION

1. The recommended size of mattress: (W) 90cm x (L) 200cm x (H) 10cm.
2. Maximum thickness of mattress: 10cm.
3. Children should be discouraged from playing on top of this bunk bed.
4. The bunk bed should be checked periodically by the owner to ensure that the guardrail, ladder, and other components are maintained in the correct position and state of repair and that all connectors are tight.
5. A bunk bed is not to be placed near a ceiling fan unless the distance between the closest points on the ceiling fan bunk. Bed is at least 2 metres.
6. Use guardrails on both sides of upper bunk.

7. Children should play sensibly in and around the bed to avoid falling and injury.
8. The bed is designed for one person on each level only.
9. Use Ladder for entering and leaving upper bunk.
10. If the bunk bed will be placed next to the wall, the guardrail that runs the full length of the bed should be placed against The wall to prevent entrapment between the bed and the wall.
11. WARNING Do not use the bunk bed/high bed if any structural part is broken or missing.
12. Ventilation of the room is necessary in order to keep the humidity low and to prevent mould in and around the bed.
13. WARNING "high beds & the upper bed of bunk beds are not suitable for children under six years due to risk of injury from falls".
14. WARNING "children can become trapped between the bed & the wall, a roof pitch, the ceiling, adjoining pieces of furniture (e.g. cupboards) and the like. To avoid risk of serious injury the distance between the top safety barrier and the adjoining structure shall not exceed 75mm or shall be more than 230mm".
15. WARNING: Always ensure the platform and the stairs are permanently attached to this bunk bed before use.
16. check regularly that all assembly fastenings are properly tightened;
17. This child bed conforms to EN 747-1 : 2024 "Furniture - Bunk beds and high beds".
18. Always follow the manufacturer's instructions.

STRANGULATION HAZARD:

19. Never attach or hang items to any part of the bunk bed that are not designed for use with the bed for example, but not limited to hooks, belts and jump ropes.
20. WARNING "Bunk Beds and high beds can present a serious risk of injury from strangulation if not used correctly. Never attach or hang items to any part of the bunk bed that are not designed to be used with the bed. for example, but not limited to ropes, strings, cords, hooks, belts and bags".
21. WARNING:This product must be attached to a wall or building structure.

WICHTIG - SORGFÄLTIG LESEN - FÜR SPÄTERE VERWENDUNG AUFBEWAHREN

TOP-TIPPS, BEVOR SIE STARTEN!

1. Bitte überprüfen Sie, ob alle Teile und Beschläge vorhanden sind, bevor Sie mit der Montage Ihrer Möbel beginnen.
2. Für eine einfache und schnelle Montage empfehlen wir, dass Sie vor jedem Montageschritt Bitte identifizieren Sie alle für diesen Schritt erforderlichen Teile.
3. Wir empfehlen, alle Artikel möglichst in der Nähe des Einsatzortes zu montieren.
um ein unnötiges Bewegen des Produkts nach der Montage zu vermeiden.
4. Zum Schutz Ihrer Möbel, insbesondere von Möbeln mit Hochglanzoberfläche, empfehlen wir, das Produkt auf einen
Geschützte Oberfläche während der Montage um eventuelle Beschädigungen zu vermeiden.
5. Achten Sie bei der Montage darauf, die Verschraubungen nicht zu fest anzuziehen, da dies zu einer Beschädigung des Produkts führen kann.

PFLEGE UND WARTUNG IHRER MÖBEL

1. Bitte überprüfen Sie regelmäßig alle Verschraubungen und ziehen Sie sie bei Bedarf nach.
2. Verwenden Sie zum Reinigen Ihres Artikels bitte ein feuchtes Tuch und wischen Sie ihn sauber.
3. Lassen Sie niemals Flüssigkeiten auf Ihren Möbeln zurück. Durch die Aufnahme kann sich das Holz verziehen oder die Oberfläche kann sich ablösen.
4. Bitte stellen Sie keine heißen Gegenstände (z. B. heiße Getränke) direkt auf die Holzoberfläche.
5. Bitte schleifen oder ziehen Sie Ihre Möbel nicht.

WICHTIGE INFORMATIONEN

1. Die empfohlene Matratzengröße: (W) 90 cm x (L) 200 cm x (H) 10 cm.
2. Maximale Matratzendicke: 10 cm.
3. Kinder sollten davon abgehalten werden, auf diesem Etagenbett zu spielen.
4. Das Etagenbett sollte regelmäßig vom Eigentümer überprüft werden, um sicherzustellen, dass Geländer, Leiter und andere Komponenten in der richtigen Position und im richtigen Zustand gehalten werden und dass alle Verbindungselemente fest sind.
5. Ein Etagenbett darf nicht in der Nähe eines Deckenventilators aufgestellt werden, es sei denn, der Abstand zwischen den nächstgelegenen Punkten des Etagenbetts mit Deckenventilator beträgt mindestens 2 Meter.

6. Verwenden Sie an beiden Seiten der oberen Koje Schutzgeländer.
7. Kinder sollten vernünftig im und um das Bett spielen, um Stürze und Verletzungen zu vermeiden.
8. Das Bett ist auf jeder Ebene nur für eine Person ausgelegt.
9. Benutzen Sie die Leiter zum Ein- und Aussteigen aus dem oberen Bett.
10. Wenn das Etagenbett neben der Wand aufgestellt wird, sollte das über die gesamte Länge des Bettes verlaufende Schutzgeländer gegen Die Wand verhindert ein Einklemmen zwischen Bett und Wand.
11. **WARNUNG** Verwenden Sie das Etagenbett/Hochbett nicht, wenn ein Bauteil gebrochen ist oder fehlt.
12. Eine Belüftung des Zimmers ist notwendig, um die Luftfeuchtigkeit niedrig zu halten und Schimmelbildung im und um das Bett vorzubeugen.
13. **WARNUNG** „Hochbetten & das Oberbett von Etagenbetten sind wegen Verletzungsgefahr durch Stürze nicht für Kinder unter sechs Jahren geeignet.“
14. **WARNUNG:** „Kinder können zwischen Bett und Wand, einer Dachschräge, der Decke, angrenzenden Möbelstücken (z. B. Schränken) und dergleichen eingeklemmt werden. Um die Gefahr schwerer Verletzungen zu vermeiden, darf der Abstand zwischen der oberen Sicherheitsbarriere und der angrenzenden Struktur 75 mm nicht überschreiten und nicht mehr als 230 mm betragen.“
15. **WARNUNG:** Stellen Sie immer sicher, dass die Plattform und die Treppe vor dem Gebrauch dauerhaft an diesem Etagenbett befestigt sind.
16. Eine Anweisung, regelmäßig zu überprüfen, ob alle Montagebefestigungen richtig angezogen sind;
17. Dieses Kinderbett entspricht EN 747- 1 : 2024 "Möbel - Etagenbetten und Hochbetten".
18. Befolgen Sie immer die Anweisungen des Herstellers.

STRANGULATIONSGEFAHR:

19. Befestigen oder hängen Sie niemals Gegenstände an Teilen des Etagenbetts auf, die nicht für die Verwendung mit dem Bett vorgesehen sind (z. B. Haken, Gürtel und Springseile).
20. **WARNUNG** „Bei unsachgemäßer Verwendung von Etagenbetten und Hochbetten besteht die Gefahr einer Strangulation. Befestigen oder hängen Sie niemals Gegenstände an Teilen des Etagenbetts auf, die nicht für die Verwendung mit dem Bett vorgesehen sind. Dies sind beispielsweise , jedoch nicht ausschließlich, Seile, Schnüre, Kordeln, Haken, Gürtel und Taschen.“
21. **WARNUNG:** Dieses Produkt muss an einer Wand oder einer Gebäudestruktur befestigt werden.

IMPORTANT- À LIRE ATTENTIVEMENT- À CONSERVER POUR RÉFÉRENCE FUTURE

LES BONS CONSEILS AVANT DE COMMENCER !

1. Veuillez vérifier que toutes les pièces et le matériel sont présents avant de commencer l'assemblage de vos meubles.
2. Pour faciliter et accélérer l'assemblage, nous vous recommandons, avant de commencer chaque étape de l'assemblage,

Veuillez identifier toutes les pièces requises pour cette étape.

3. Nous recommandons que, dans la mesure du possible, tous les articles soient assemblés à proximité de la zone dans laquelle ils seront utilisés,

pour éviter de déplacer inutilement le produit une fois assemblé.

4. Pour la protection de vos meubles, en particulier des articles à finition brillante, nous vous recommandons de placer le produit sur un

Surface protégée lors du montage pour éviter tout dommage.

5. Lors de l'assemblage, veillez à ne pas trop serrer les raccords, car cela pourrait endommager le produit.

SOIN ET ENTRETIEN DE VOS MEUBLES

1. Veuillez vérifier périodiquement tous les raccords et resserrer si nécessaire.
2. Pour nettoyer votre article, veuillez utiliser un chiffon humide et essuyer.
3. Ne laissez jamais aucun type de liquide rester sur vos meubles. L'absorption peut provoquer la déformation du bois ou le délaminage des finitions.
4. Veuillez ne pas placer d'objets chauds (par exemple des boissons chaudes) directement sur la surface du bois.
5. Veuillez ne pas traîner ou tirer vos meubles.

UNE INFORMATION IMPORTANT

1. La taille recommandée du matelas : (W) 90 cm x (L) 200 cm x (H) 10 cm.
2. Épaisseur maximale du matelas : 10 cm.
3. Il convient de décourager les enfants de jouer sur ce lit superposé.
4. Le lit superposé doit être vérifié périodiquement par le propriétaire pour s'assurer que le garde-corps, l'échelle et les autres composants sont maintenus dans la bonne position et en bon état et que tous les connecteurs sont bien serrés.

5. Un lit superposé ne doit pas être placé à proximité d'un ventilateur de plafond, à moins que la distance entre les points les plus proches du ventilateur de plafond ne soit respectée. Le lit mesure au moins 2 mètres.
6. Utilisez des garde-corps des deux côtés du lit supérieur.
7. Les enfants doivent jouer raisonnablement dans et autour du lit pour éviter les chutes et les blessures.
8. Le lit est conçu pour une seule personne à chaque niveau.
9. Utilisez l'échelle pour entrer et sortir du lit supérieur.
10. Si le lit superposé doit être placé près du mur, le garde-corps qui s'étend sur toute la longueur du lit doit être placé contre le mur pour éviter tout coincement entre le lit et le mur.
11. AVERTISSEMENT N'utilisez pas le lit superposé/lit surélevé si une pièce structurelle est cassée ou manquante.
12. La ventilation de la pièce est nécessaire afin de maintenir un faible taux d'humidité et d'éviter la moisissure dans et autour du lit.
13. AVERTISSEMENT "les lits hauts et le lit supérieur des lits superposés ne conviennent pas aux enfants de moins de six ans en raison du risque de blessure en cas de chute".
14. AVERTISSEMENT "Les enfants peuvent se retrouver coincés entre le lit et le mur, une pente de toit, le plafond, des meubles attenants (par exemple des placards) et autres. Pour éviter tout risque de blessure grave, la distance entre la barrière de sécurité supérieure et la barrière de sécurité adjacente la structure ne doit pas dépasser 75 mm ni dépasser 230 mm".
15. AVERTISSEMENT: Vérifiez toujours que la plate-forme et l'escalier sont fixés de manière permanente à ce lit superposé avant de l'utiliser.
16. Une déclaration demandant de vérifier régulièrement que toutes les fixations de l'assemblage sont correctement serrées ;
17. Ce lit enfant est conforme aux normes EN 747- 1 : 2024 "Meubles - Lits superposés et lits hauts".
18. Suivez toujours les instructions du fabricant.

RISQUE D'ÉTRANGULATION :

19. N'attachez ou ne suspendez jamais d'objets à une partie du lit superposé qui ne sont pas conçus pour être utilisés avec le lit, par exemple, mais sans s'y limiter, des crochets, des ceintures et des cordes à sauter.
20. AVERTISSEMENT "Les lits superposés et les lits hauts peuvent présenter un risque sérieux de blessure par strangulation s'ils ne sont pas utilisés correctement. N'attachez ou ne suspendez jamais d'objets à une partie du lit superposé qui ne sont pas conçus pour être utilisés avec le lit. par exemple, mais sans s'y limiter, les cordes, ficelles, cordons, crochets, ceintures et sacs".
21. AVERTISSEMENT : Ce produit doit être fixé à un mur ou à la structure d'un bâtiment.

IMPORTANTE- LEER CON ATENCIÓN-

CONSERVAR PARA FUTURA REFERENCIA

¡MEJORES CONSEJOS ANTES DE COMENZAR!

1. Verifique que todas las piezas y herrajes estén presentes antes de comenzar a ensamblar sus muebles.

2. Para facilitar y acelerar el montaje, recomendamos que antes de comenzar cada paso del montaje,

Identifique todas las piezas necesarias para ese paso.

3. Recomendamos que, siempre que sea posible, todos los artículos se monten cerca del área en la que se utilizarán.

para evitar mover el producto innecesariamente una vez montado.

4. Para la protección de sus muebles, especialmente los artículos con acabado de alto brillo, recomendamos colocar el producto sobre una

Superficie protegida durante el montaje para evitar cualquier daño.

5. Durante el montaje, tenga cuidado de no apretar demasiado ningún accesorio, ya que esto podría dañar el producto.

CUIDADO Y MANTENIMIENTO DE TUS MUEBLES

1. Revise periódicamente todos los accesorios y vuelva a apretarlos según sea necesario.

2. Para limpiar su artículo, utilice un paño húmedo y límpielo.

3. Nunca permita que quede ningún tipo de líquido en sus muebles. La absorción puede causar que la madera se deforme o que los acabados se deslaminen.

4. No coloque artículos calientes (por ejemplo, bebidas calientes) directamente sobre la superficie de madera.

5. No arrastre ni tire de sus muebles.

INFORMACIÓN IMPORTANTE

1. El tamaño recomendado del colchón: (W) 90 cm x (L) 200 cm x (H) 10 cm.

2. Grosor máximo del colchón: 10cm.

3. Se debe disuadir a los niños de jugar encima de esta litera.

4. El propietario debe revisar periódicamente la litera para garantizar que la barandilla, la escalera y otros componentes se mantengan en la posición y estado correctos y que todos los conectores estén apretados.

5. No se debe colocar una litera cerca de un ventilador de techo a menos que la distancia entre los puntos más cercanos de la litera del ventilador de techo. La cama mide al menos 2 metros.
6. Utilice barandillas a ambos lados de la litera superior.
7. Los niños deben jugar con sensatez dentro y alrededor de la cama para evitar caídas y lesiones.
8. La cama está diseñada para una persona en cada nivel únicamente.
9. Utilice la escalera para entrar y salir de la litera superior.
10. Si la litera se va a colocar junto a la pared, la barandilla que recorre toda la longitud de la cama debe colocarse contra la pared para evitar atrapamientos entre la cama y la pared.
11. ADVERTENCIA No utilice la litera/cama alta si alguna pieza estructural está rota o falta.
12. La ventilación de la habitación es necesaria para mantener baja la humedad y evitar moho dentro y alrededor de la cama.
13. ADVERTENCIA "Las camas altas y la cama superior de las literas no son adecuadas para niños menores de seis años debido al riesgo de lesiones por caídas".
14. ADVERTENCIA "Los niños pueden quedar atrapados entre la cama y la pared, la pendiente del tejado, el techo, los muebles contiguos (por ejemplo, armarios) y similares. Para evitar el riesgo de lesiones graves, la distancia entre la barrera de seguridad superior y la barrera de seguridad contigua La estructura no excederá los 75 mm ni excederá los 230 mm".
15. ADVERTENCIA: Asegúrese siempre de que la plataforma y la escalera están fijadas permanentemente a esta litera antes de su uso.
16. Una declaración para comprobar regularmente que todas las fijaciones de montaje están bien apretadas;
17. Esta cama infantil cumple con EN 747-1 : 2024 "Mobiliario - Literas y camas altas".
18. Siga siempre las instrucciones del fabricante.

PELIGRO DE ESTRANGULACIÓN:

19. Nunca coloque ni cuelgue elementos en ninguna parte de la litera que no estén diseñados para usarse con la cama, por ejemplo, entre otros, ganchos, cinturones y cuerdas para saltar.
20. ADVERTENCIA "Las literas y las camas altas pueden presentar un riesgo grave de lesiones por estrangulamiento si no se usan correctamente. Nunca fije ni cuelgue elementos en ninguna parte de la litera que no estén diseñados para usarse con la cama, por ejemplo, pero no limitado a cuerdas, cordeles, cordones, ganchos, cinturones y bolsas".
21. ADVERTENCIA: Este producto debe fijarse a una pared o a la estructura de un edificio.

IMPORTANTE - LEGGERE ATTENTAMENTE -

CONSERVARE PER RIFERIMENTO FUTURO

I MIGLIORI CONSIGLI PRIMA DI INIZIARE!

1. Verificare che tutte le parti e l'hardware siano presenti prima di iniziare l'assemblaggio dei mobili.
2. Per facilitare e velocizzare l'assemblaggio, si consiglia prima di iniziare ogni fase dell'assemblaggio, identificare tutte le parti necessarie per questo passaggio.
3. Raccomandiamo, ove possibile, che tutti gli articoli siano assemblati vicino all'area in cui verranno utilizzati, per evitare di spostare inutilmente il prodotto una volta assemblato.
4. Per la protezione dei tuoi mobili, in particolare degli articoli con finitura lucida, ti consigliamo di posizionare il prodotto su a Superficie protetta durante il montaggio per evitare eventuali danni.
5. Durante il montaggio fare attenzione a non stringere eccessivamente i raccordi, poiché ciò potrebbe danneggiare il prodotto.

CURA E MANUTENZIONE DEI VOSTRI MOBILI

1. Controllare periodicamente tutti i raccordi e serrarli nuovamente se necessario.
2. Per pulire l'articolo, utilizzare un panno umido e pulirlo.
3. Non lasciare mai alcun tipo di liquido sui mobili. L'assorbimento può causare la deformazione del legno o la delaminazione delle finiture.
4. Si prega di non posizionare oggetti caldi (ad esempio bevande calde) direttamente sulla superficie del legno.
5. Si prega di non trascinare o tirare i mobili.

INFORMAZIONI IMPORTANTI

1. Dimensioni consigliate del materasso: (W) 90 cm x (L) 200 cm x (H) 10 cm.
2. Spessore massimo del materasso: 10 cm.
3. I bambini dovrebbero essere scoraggiati dal giocare sul letto a castello.
4. Il letto a castello deve essere controllato periodicamente dal proprietario per garantire che il parapetto, la scala e gli altri componenti siano mantenuti nella posizione corretta e in stato di riparazione e che tutti i connettori siano serrati.
5. Un letto a castello non deve essere posizionato vicino a un ventilatore da soffitto, a meno che non sia rispettata la distanza tra i punti più vicini sul letto a castello. Il letto è di almeno 2 metri.

6. Utilizzare le sponde su entrambi i lati del letto superiore
7. I bambini dovrebbero giocare in modo sensato dentro e intorno al letto per evitare cadute e lesioni.
8. Il letto è previsto per una sola persona su ogni livello.
9. Usa la scala per entrare e uscire dalla cuccetta superiore.
10. Se il letto a castello verrà posizionato vicino al muro, la ringhiera che corre per tutta la lunghezza del letto deve essere posizionata contro il muro per evitare intrappolamenti tra il letto e il muro.
11. **ATTENZIONE** Non utilizzare il letto a castello/letto sopraelevato se qualche parte strutturale è rotta o mancante.
12. La ventilazione della stanza è necessaria per mantenere bassa l'umidità e prevenire la formazione di muffe all'interno e attorno al letto.
13. **ATTENZIONE** "I letti alti e il letto superiore dei letti a castello non sono adatti a bambini di età inferiore a sei anni a causa del rischio di lesioni dovute a cadute".
14. **AVVERTENZA** "I bambini possono rimanere intrappolati tra il letto e il muro, la falda del tetto, il soffitto, i mobili adiacenti (ad esempio armadi) e simili. Per evitare il rischio di lesioni gravi, la distanza tra la barriera di sicurezza superiore e quella adiacente la struttura non deve superare i 75 mm né essere superiore ai 230 mm".
15. **AVVERTENZA:** Assicurarsi sempre che la piattaforma e la scala siano fissate in modo permanente a questo letto a castello prima dell'uso.
16. Una dichiarazione di controllare regolarmente che tutti i fissaggi di montaggio siano correttamente serrati;
17. Questo lettino è conforme alle norme EN 747-1 : 2024 "Mobili - Letti a castello e letti alti".
18. Seguire sempre le istruzioni del produttore.

PERICOLO DI STRANGOLAMENTO:

19. Non attaccare o appendere mai oggetti a qualsiasi parte del letto a castello che non siano progettati per l'uso con il letto, ad esempio, ma non limitati a ganci, cinture e corde per saltare.
20. **AVVERTENZA** "I letti a castello e i letti alti possono presentare un grave rischio di lesioni da strangolamento se non utilizzati correttamente. Non attaccare o appendere mai oggetti a qualsiasi parte del letto a castello che non siano progettati per essere utilizzati con il letto, ad esempio, ma non limitato a corde, spaghi, corde, ganci, cinture e borse".
21. **AVVERTENZA:** Questo prodotto deve essere fissato a una parete o a una struttura dell'edificio.

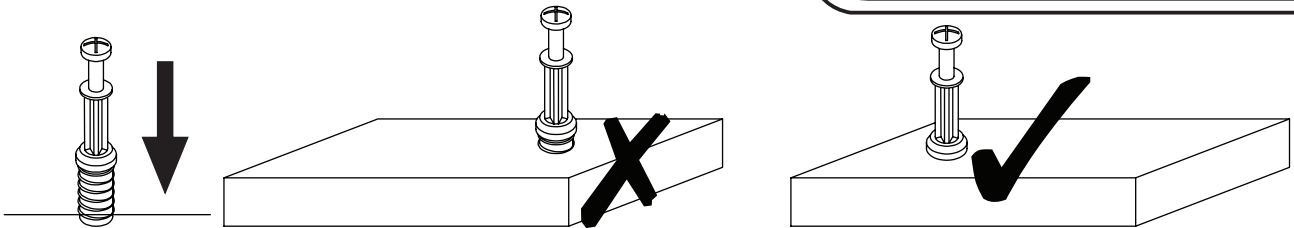

EN_QUICKFIT: Tighten quickfit until shoulder is flush with panel. Do not overtighten or undertighten.

FR_RACCORD RAPIDE: Faites serrer le raccord rapide jusqu'à ce que l'épaulement soit parfaitement encastré dans le panneau. Il ne faut ni trop serrer ni insuffisamment serrer.

ES_QUICKFIT: Apriete quickfit hasta que el hombro se descargue con el panel. NO lo sobreapriete ni lo apriete poco.

DE_QUICKFIT: Ziehen Sie den Quickfit fest, bis die Schulter mit der Platte bündig ist. Bitte nicht zu fest oder zu schwach anziehen.

IT_MONTAGGIO RAPIDO: Stringere il montaggio rapido fino a quando la spalla è a filo con il pannello, non stringere troppo o troppo poco.

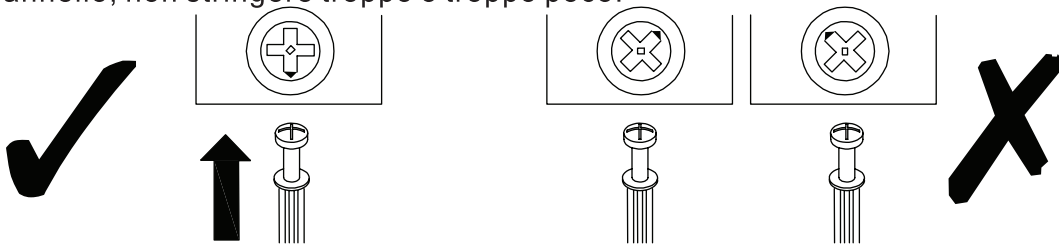

EN_CAM LOCK: When fitting cam lock, ensure starting position is correct before you insert connecting quickfit.

FR_SERRURE BATTEUSE: Avant d'insérer la serrure batteuse, veillez à la bonne orientation avant d'insérer le raccord rapide.

ES_CIERRE DE LA CÁMARA: Cuando instale el cierre de la cámara, asegúrese de que la posición de inicio es correcta antes de que inserte el quickfit conector.

DE_CAM-LOCK: Achten Sie bei der Montage des Cam-Locks auf die richtige Ausgangsposition, bevor Sie den Quickfit einsetzen.

IT_BLOCCAGGIO A CAMMA: Quando si monta il bloccaggio a camma, assicurarsi che la posizione iniziale sia corretta prima di inserire il montaggio rapido di collegamento.

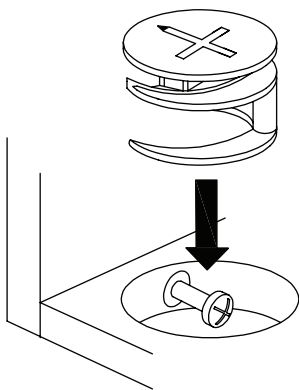

EN_Quickfit head should be in the centre of the cam lock when the two panels are joined.

Cam lock should be inserted before quickfit.

FR_Lorsque les deux panneaux sont assemblés, la tête du raccord rapide doit reposer au centre de la serrure batteuse. Il faut insérer la serrure batteuse avant le raccord rapide.

ES_El cabezal del quickfit debe estar en el centro del cierre de la cámara cuando se unan los dos paneles.

Se debe insertar el cierre de la cámara antes que el quickfit.

DE_Der Quickfit-Kopf sollte sich in der Mitte des Cam-Locks befinden, wenn die beiden Platten zusammengefügt sind. Der Cam-Lock sollte vor dem Quickfit eingesetzt werden.

IT_La testa del montaggio rapido deve trovarsi al centro del bloccaggio a camma quando i due pannelli sono uniti.

Il Bloccaggio a Camma deve essere inserito prima del montaggio rapido.

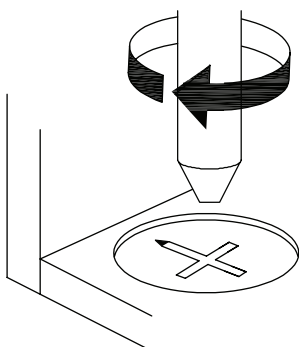

EN_Turn cam lock clockwise to tighten.

FR_Faites tourner la serrure batteuse dans le sens des aiguilles d'une montre pour la resserrer.

ES_Gire el cierre de la cámara en sentido horario para apretarlo.

DE_Drehen Sie den Cam-Lock im Uhrzeigersinn, um ihn festzuziehen.

IT_Ruotare il bloccaggio a camma in senso orario per stringere.

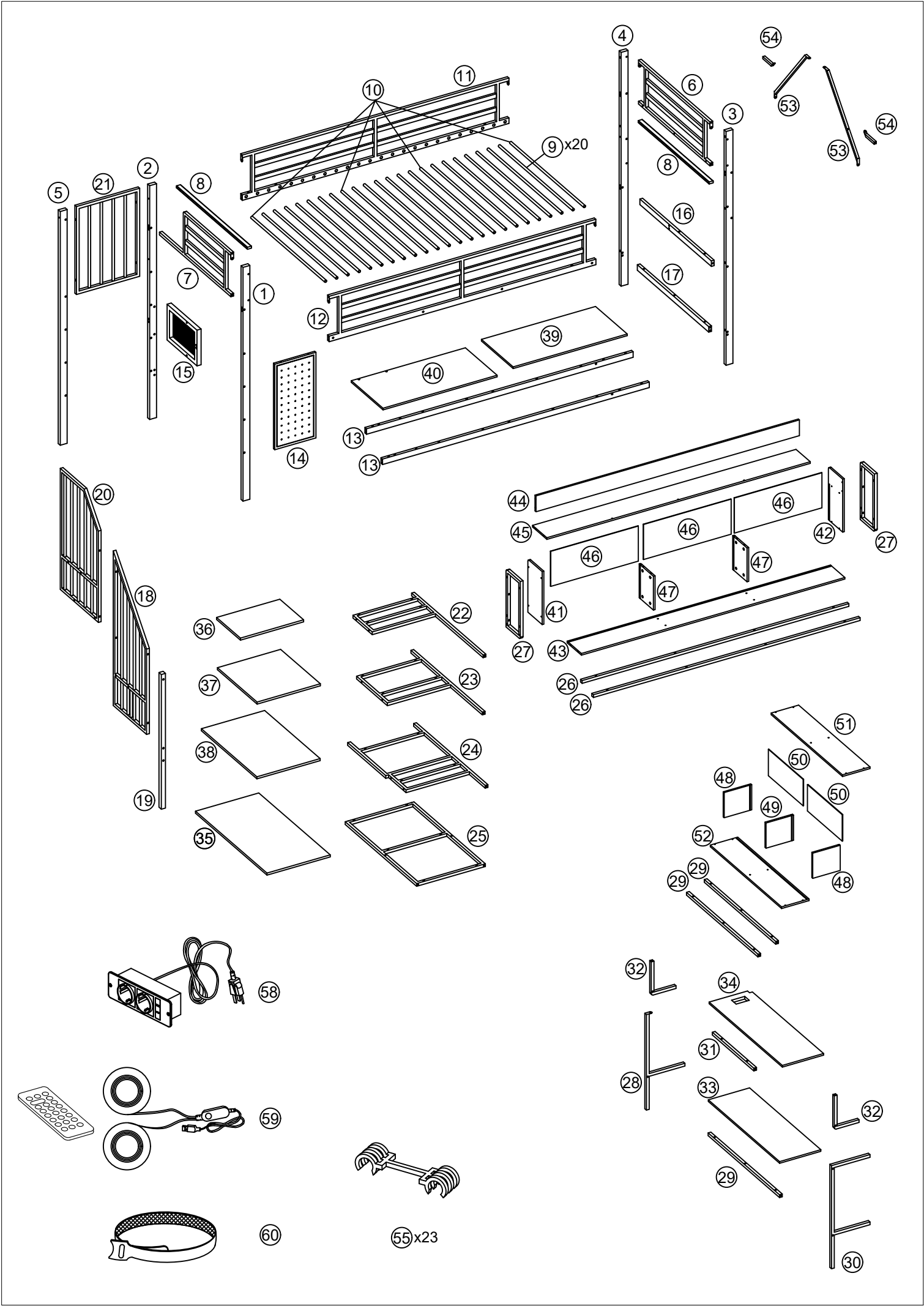

Part List/Teileliste/Liste des pièces

N616P418295

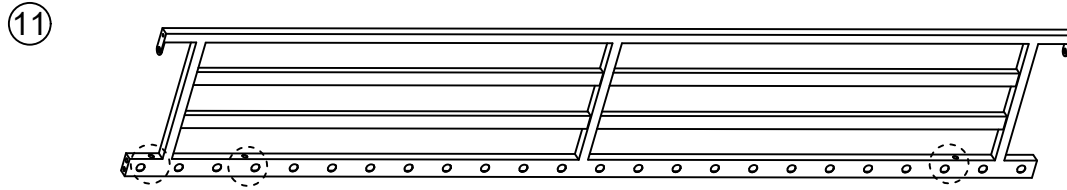

1pc

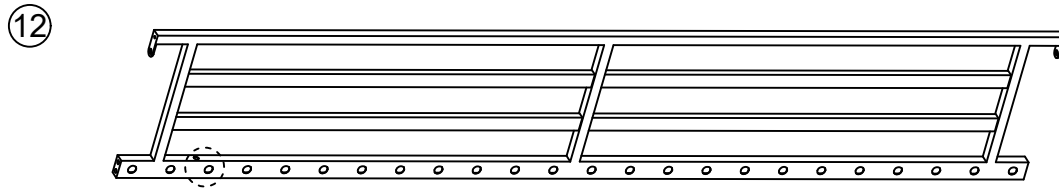

1pc

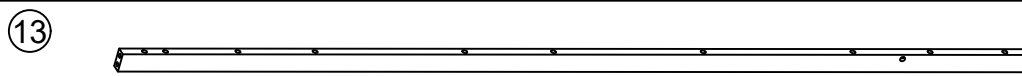

2pcs

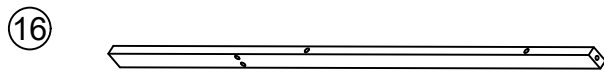

1pc



1pc

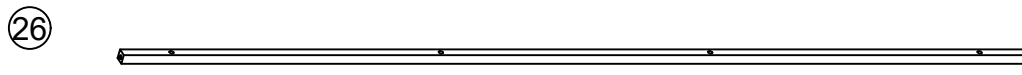

2pcs

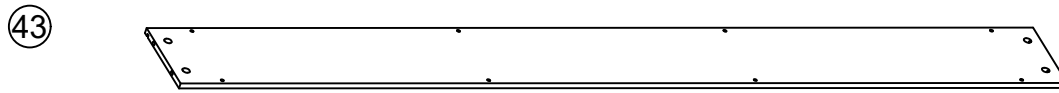

1pc

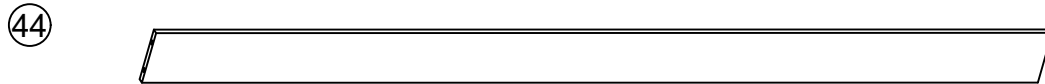

1pc

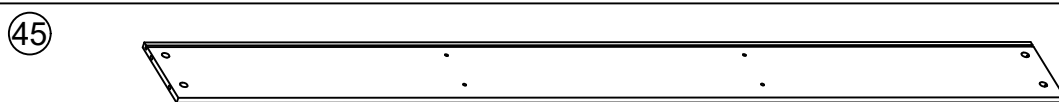

1pc

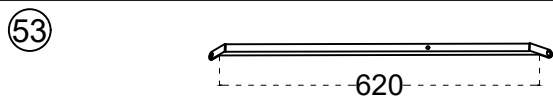







2pcs

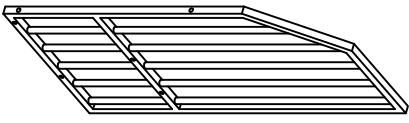
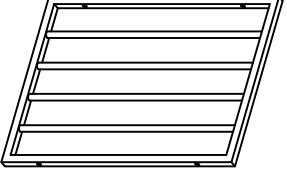
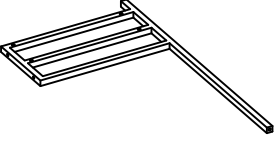
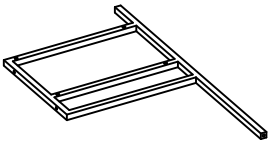
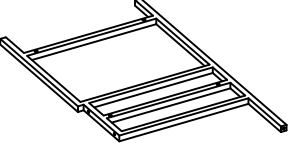
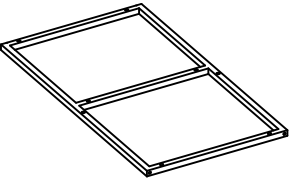

2pcs

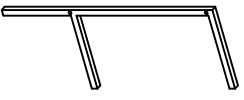
Part List/Teileliste/Liste des pièces

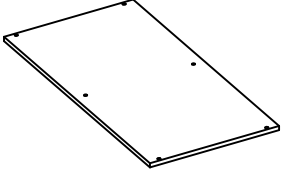
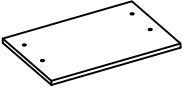
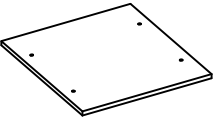
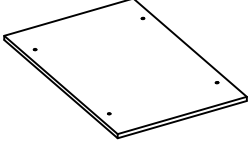
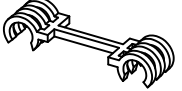
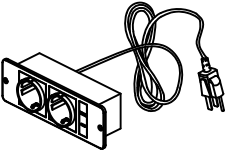
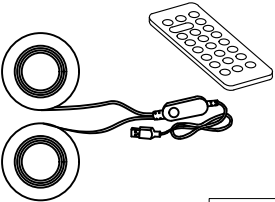
N616P418296

<p>⑮</p>  <p>1pc</p>	<p>⑳</p>  <p>1pc</p>		
<p>㉑</p>  <p>1pc</p>	<p>㉒</p>  <p>1pc</p>		
<p>㉓</p>  <p>1pc</p>	<p>㉔</p>  <p>1pc</p>		
<p>㉕</p>  <p>1pc</p>	<p>㉗</p>  <p>2pcs</p>		
<p>⑳</p>  <p>1pc</p>	<p>㉙</p>  <p>2pcs</p>		
<p>㉛</p>  <p>1pc</p>	<p>㉜</p>  <p>1pc</p>		
<p>㉝</p>  <p>1pc</p>	<p>㉞</p>  <p>1pc</p>		
<p>⑥⑤</p>  <p>23pcs</p>	<p>⑥⑧</p>  <p>1pc</p>	<p>⑥⑨</p>  <p>1pc</p>	<p>⑥⑩</p>  <p>1pc</p>

Part List/Teileliste/Liste des pièces

N616P418297

18

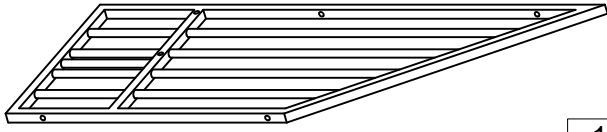

1pc

33

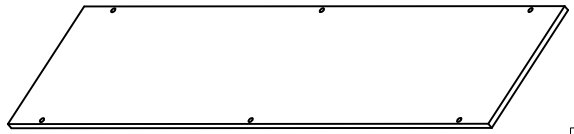

1pc

34



1pc

39

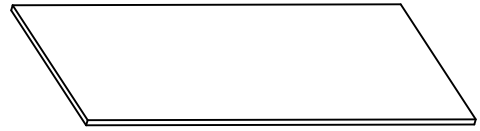

1pc

40



1pc

41



1pc

42

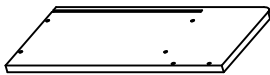

1pc

46



3pcs

47

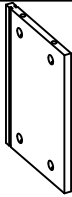

2pcs

48

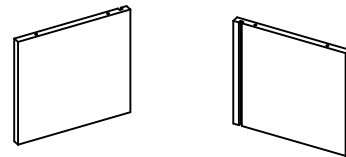

2pcs

49

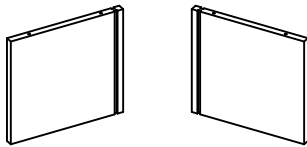

1pc

50



2pcs

51

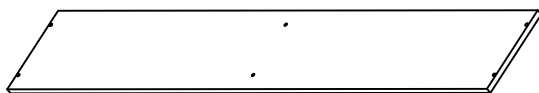

1pc

52

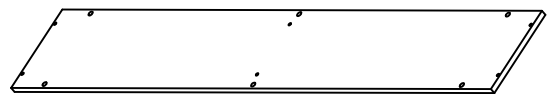







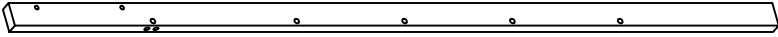
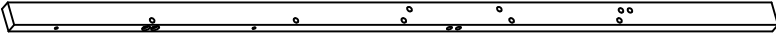
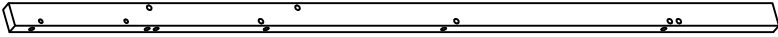
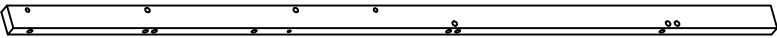
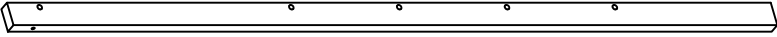
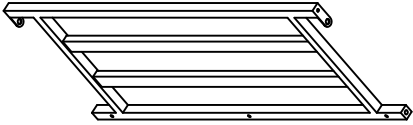
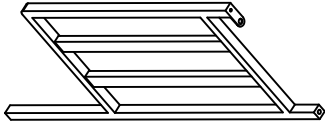
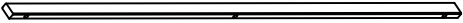
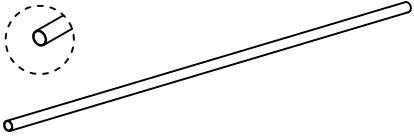
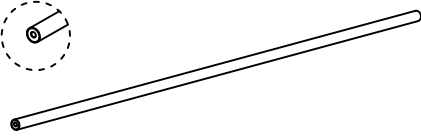
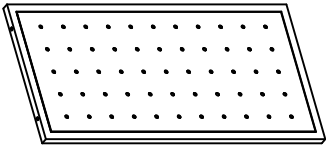
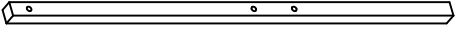
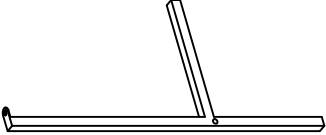
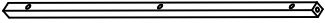
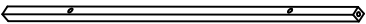



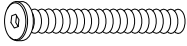
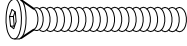
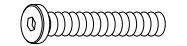
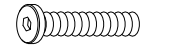
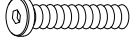
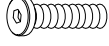

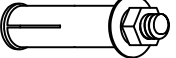





1pc

Part List/Teileliste/Liste des pièces

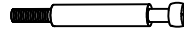
N616P418298

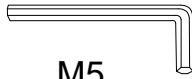

①	 <div style="text-align: right;">1pc</div>		
②	 <div style="text-align: right;">1pc</div>		
③	 <div style="text-align: right;">1pc</div>		
④	 <div style="text-align: right;">1pc</div>		
⑤	 <div style="text-align: right;">1pc</div>		
⑥	 <div style="text-align: right;">1pc</div>	⑦	 <div style="text-align: right;">1pc</div>
⑧	 <div style="text-align: right;">2pcs</div>	⑨	 <div style="text-align: right;">20pcs</div>
⑩	 <div style="text-align: right;">4pcs</div>	⑭	 <div style="text-align: right;">1pc</div>
⑰	 <div style="text-align: right;">1pc</div>	⑳	 <div style="text-align: right;">1pc</div>
㉑	 <div style="text-align: right;">3pcs</div>	㉓	 <div style="text-align: right;">1pc</div>

Hardware List/ Hardware-Liste/ Liste du matériel N616P418296

<p>(A)  M8×70mm 15pcs</p>	<p>(B)  M8×70mm 2pcs</p>	<p>(C)  M8×55mm 4pcs</p>	<p>(D)  M8×45mm 11pcs</p>
<p>(E)  M8×40mm 23pcs</p>	<p>(F)  M8×35mm 15pcs</p>	<p>(G)  M8×20mm 13pcs</p>	<p>(H)  2pcs</p>
<p>(I)  2pcs</p>	<p>(J)  1pc</p>	<p>(K)  M6×65mm 2pcs</p>	<p>(L)  M6×48mm 23pcs</p>
<p>(M)  M6×40mm 14pcs</p>	<p>(N)  M6×30mm 51pcs</p>	<p>(O)  M6×15mm 12pcs</p>	<p>(P)  M4×30mm 12pcs</p>
<p>(Q)  M3×12mm 2pcs</p>	<p>(R)  M6×17mm 4pcs</p>	<p>(S)  6×35mm 23pcs</p>	<p>(T)  Ø15×9.5mm 23pcs</p>
<p>(U)  10pcs</p>	<p>(V)  1pc</p>	<p>(W)  M5 1pc</p>	<p>(X)  M4 2pcs</p>

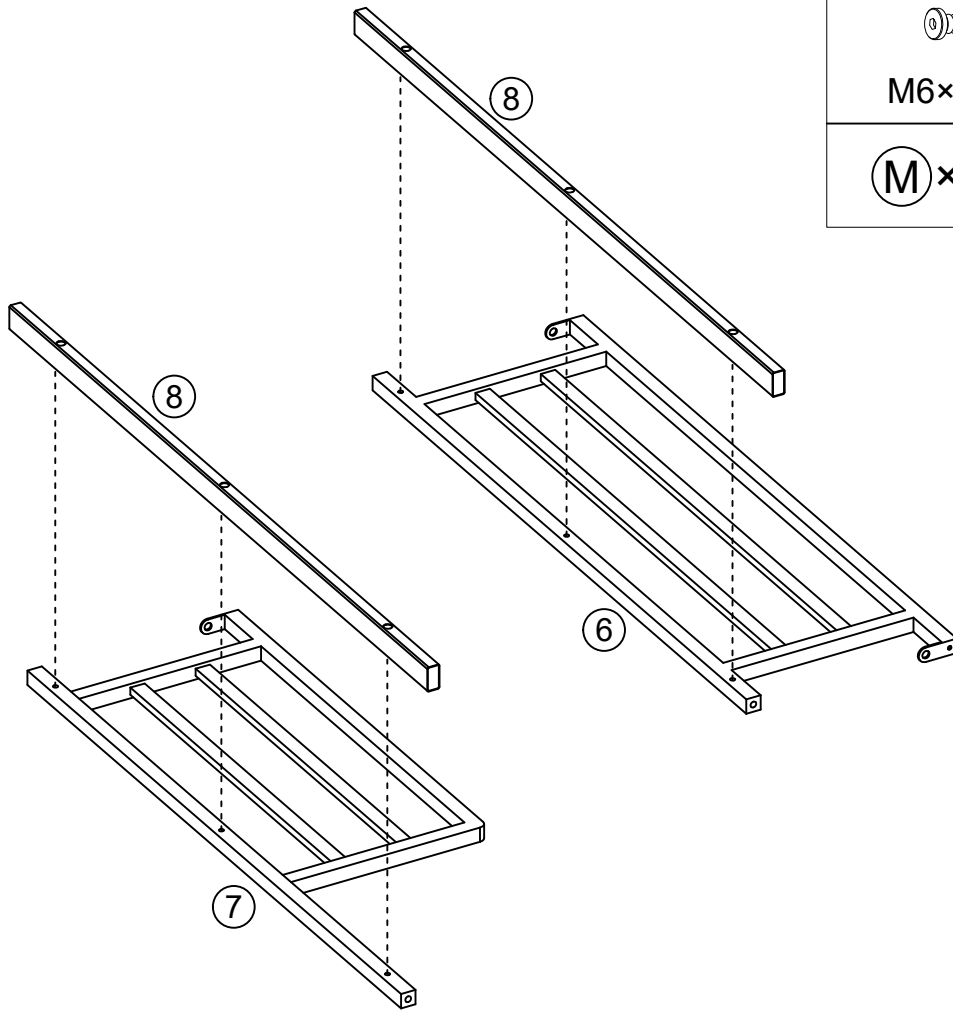
1





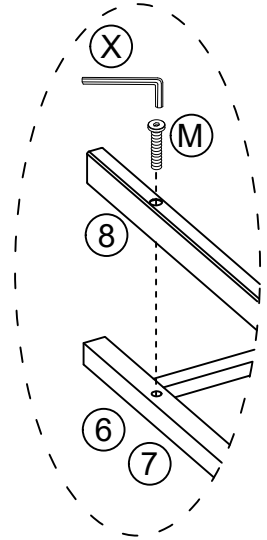

	
M6×40mm	M4
(M)×6PCS	(X)×1PC

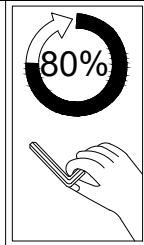

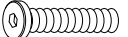
2



		
M8×40mm	M8×20mm	M5
(E)×2PCS	(G)×1PC	(W)×1PC



	
M8×20mm	M5
(G)×1PC	(W)×1PC

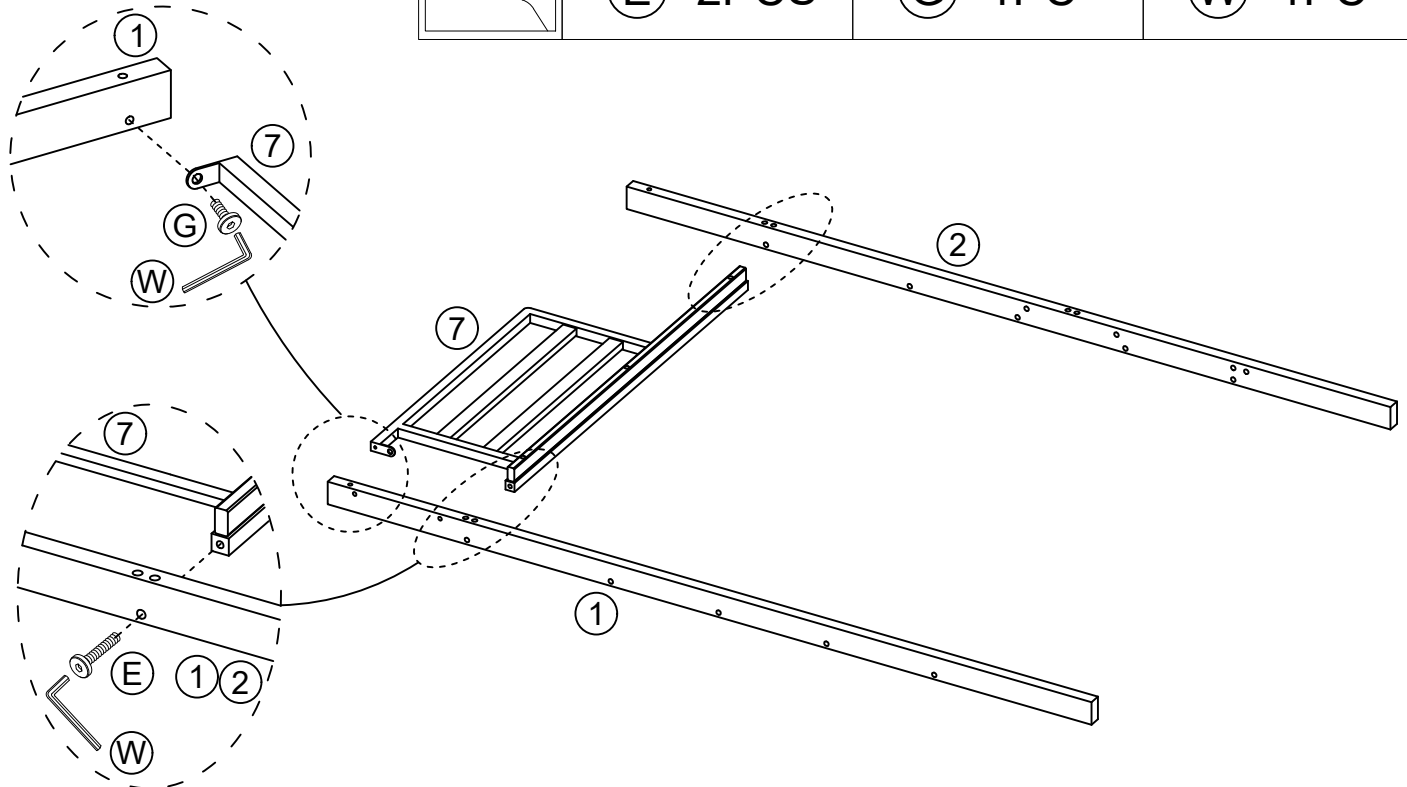

M5
(W)×1PC

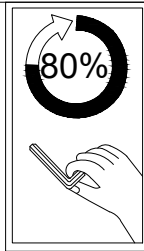

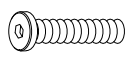
3





 M8×40mm	 M8×20mm	 M5
(E) × 2PCS	(G) × 2PCS	(W) × 1PC

 M8×20mm	 M5
(G) × 2PCS	(W) × 1PC

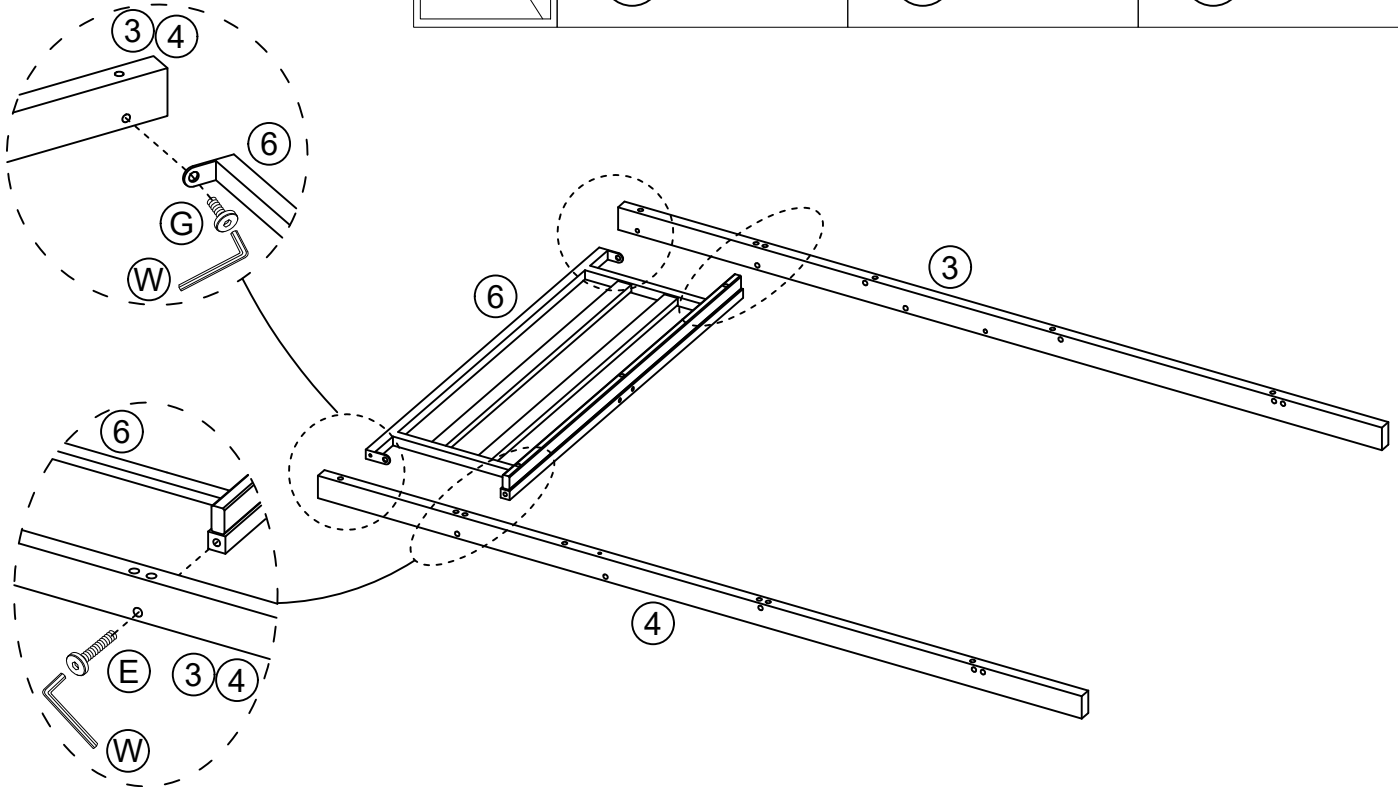
 M5
(W) × 1PC

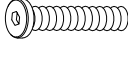

4

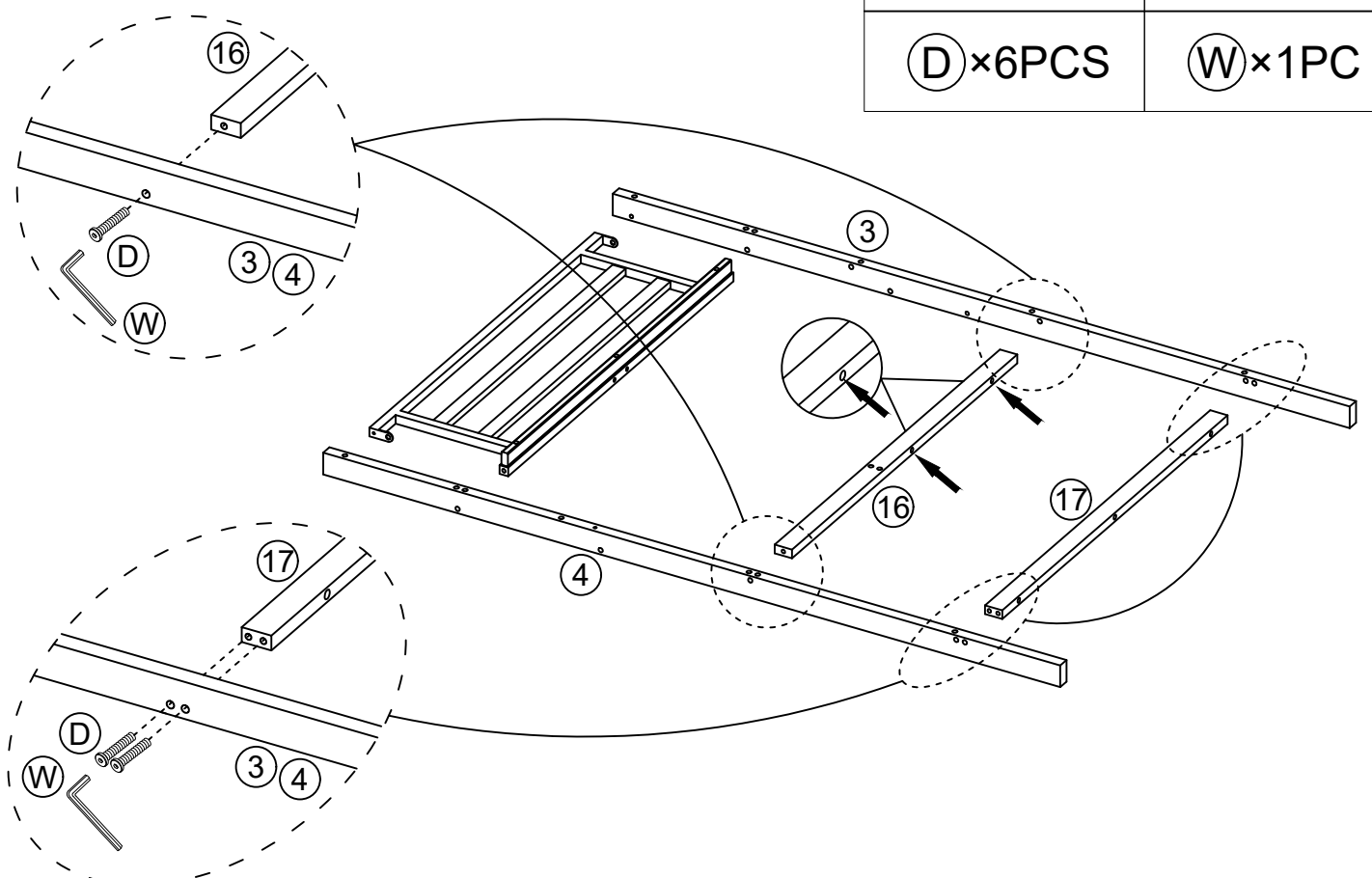

 M8×45mm	 M5
(D) × 6PCS	(W) × 1PC

 M5
(W) × 1PC

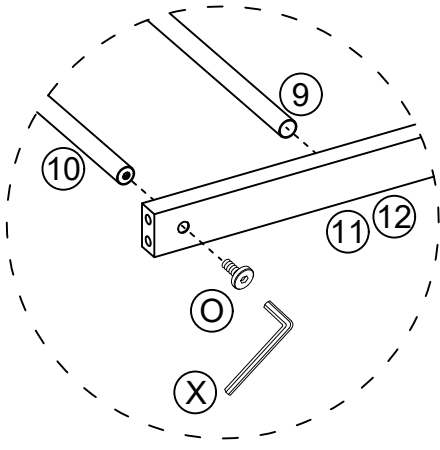

5



	
M6*15mm	M4
⊙×8PCS	⊗×1PC

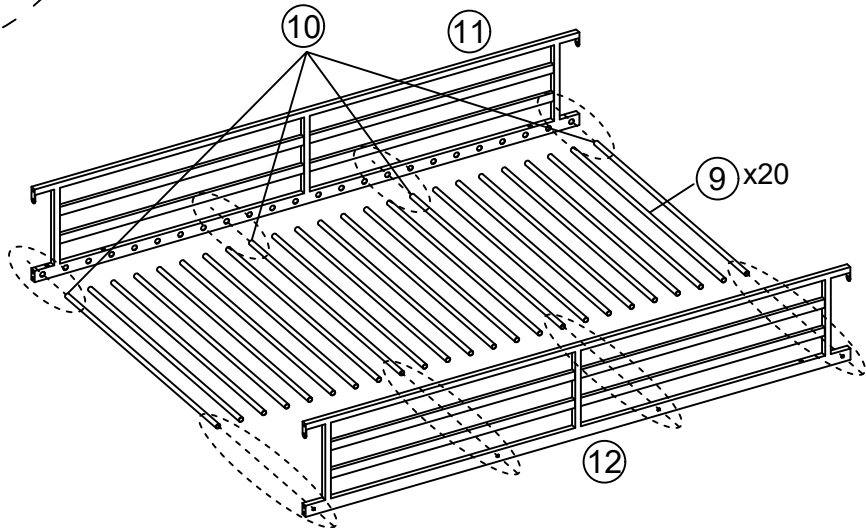

6

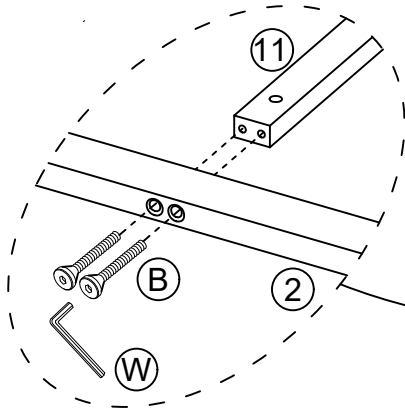
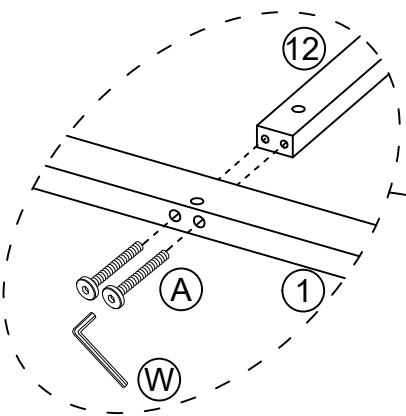

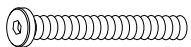
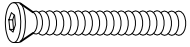
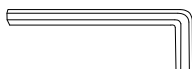
		
M8*70mm	M8*70mm	M5
⊙A×2PCS	⊙B×2PCS	⊙W×1PC

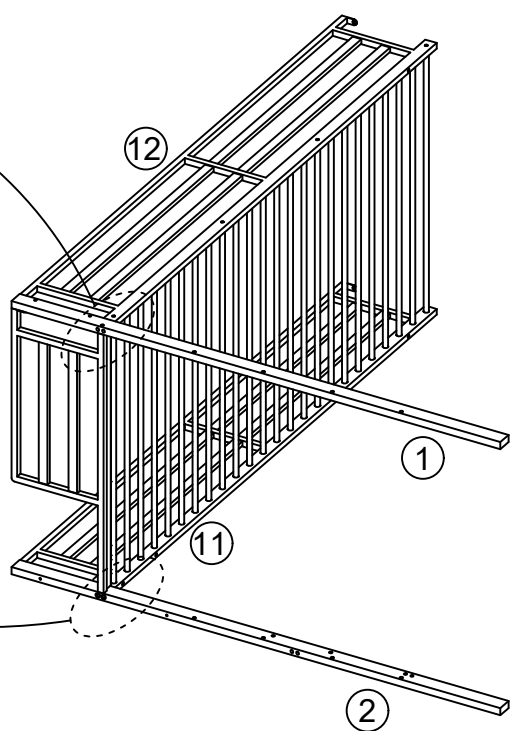

7



M8×20mm



M5

ⓐ×2PCS

Ⓦ×1PC

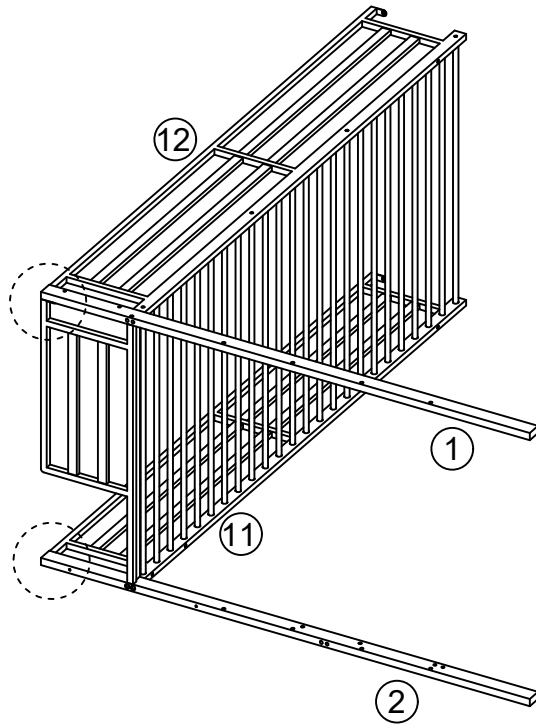
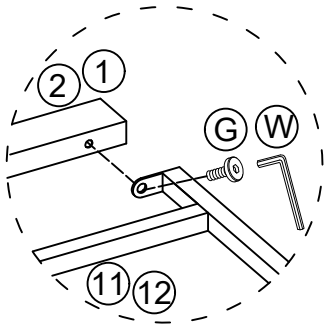

8

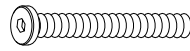

M8*70mm



M8×20mm



M5



ⓐ×4PCS

ⓐ×2PCS

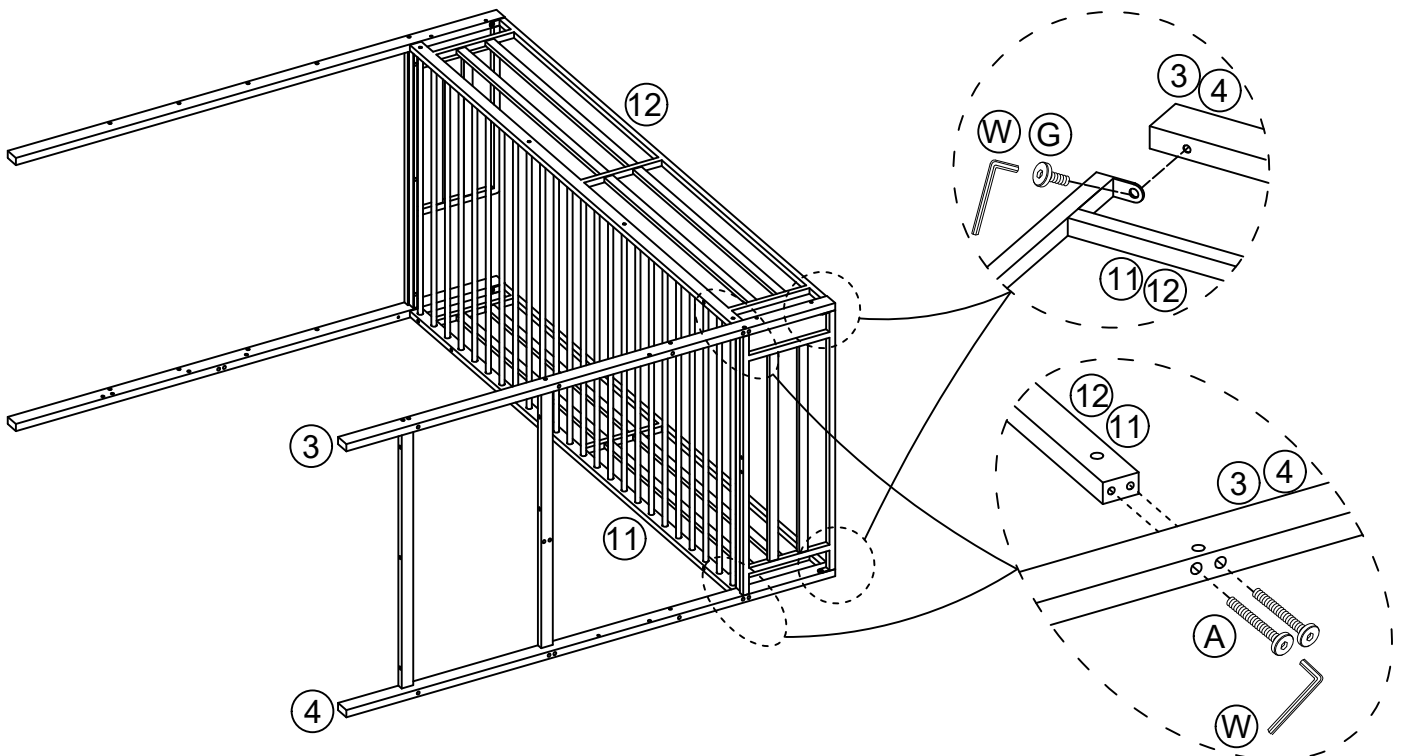
Ⓦ×1PC



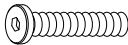

9

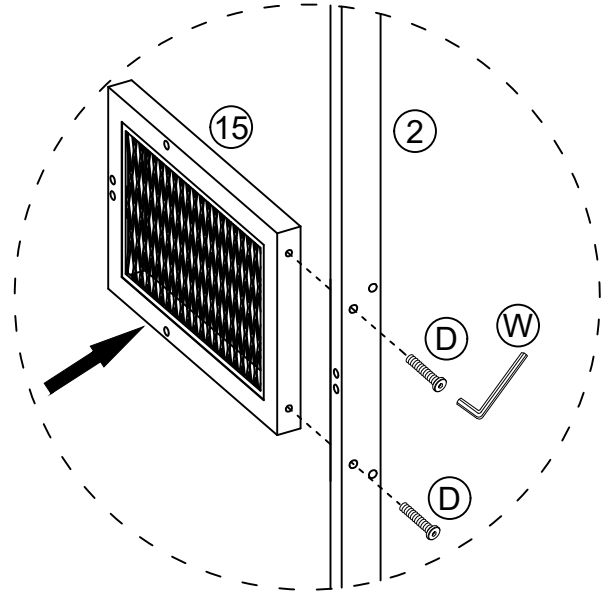
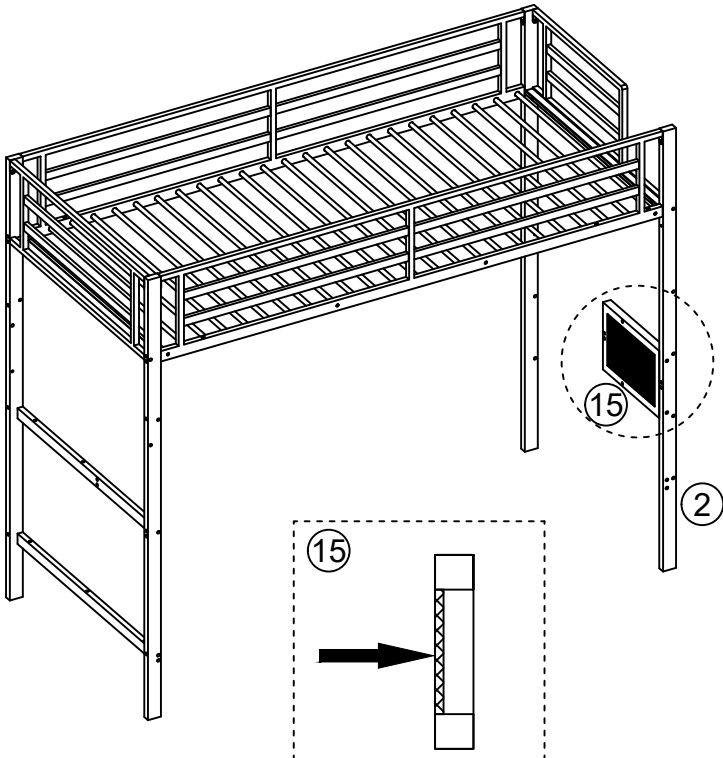
	
M8×45mm	M5
(D) ×2PCS	(W) ×1PC

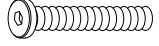
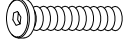

10

		
M8×55mm	M8×40mm	M5
(C) ×2PCS	(E) ×2PCS	(W) ×1PC

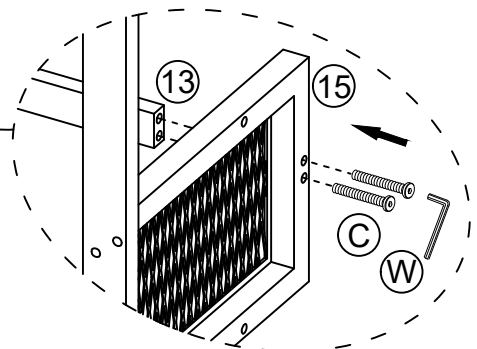
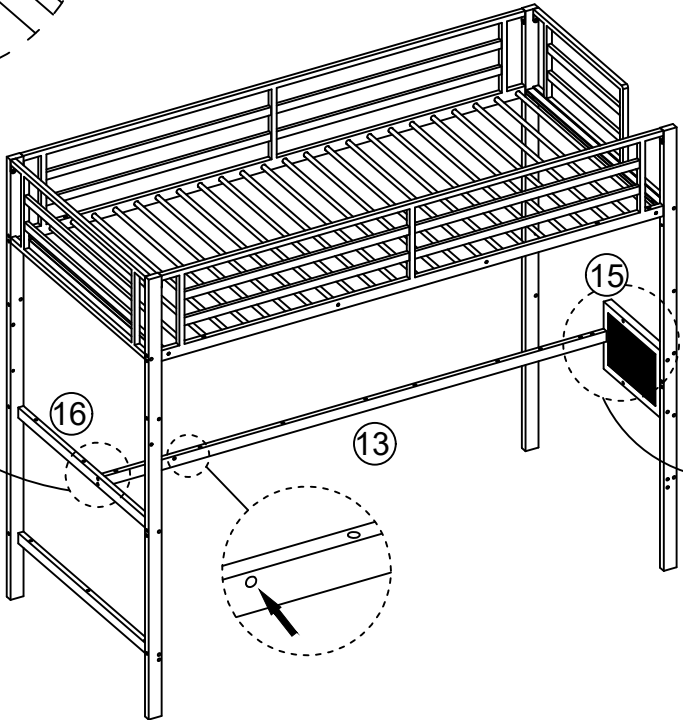
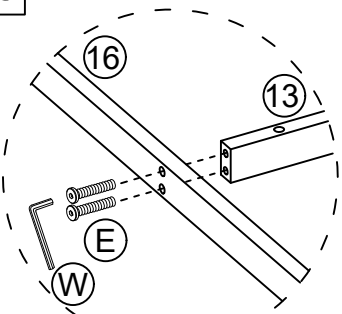

11



M8*70mm

(A) × 4PCS



M5

(W) × 1PC

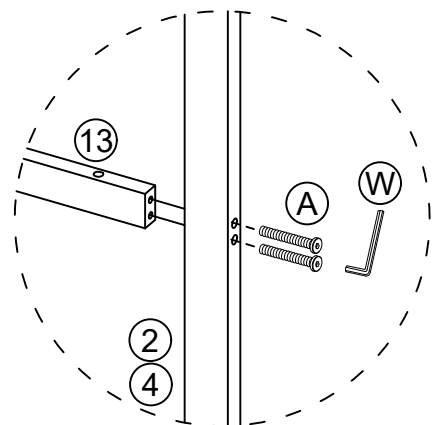
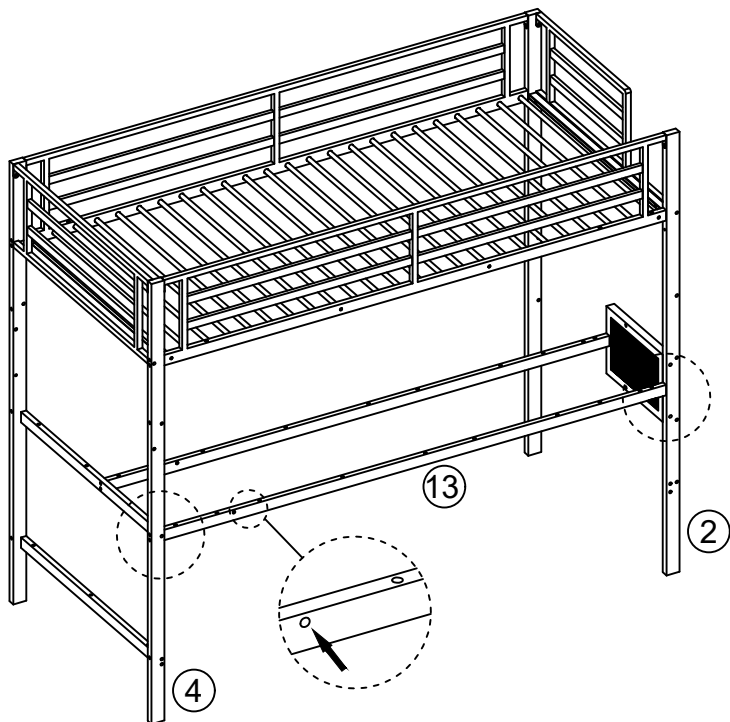

12

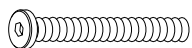

M8*70mm

(A) × 2PCS

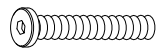

M8*55mm

(C) × 2PCS



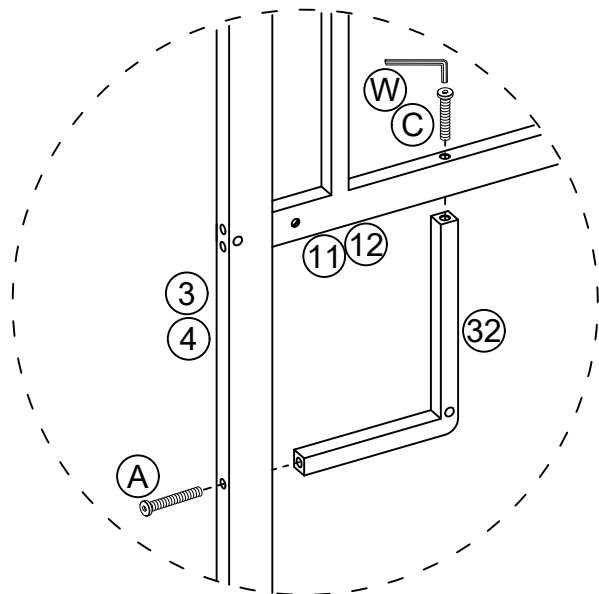
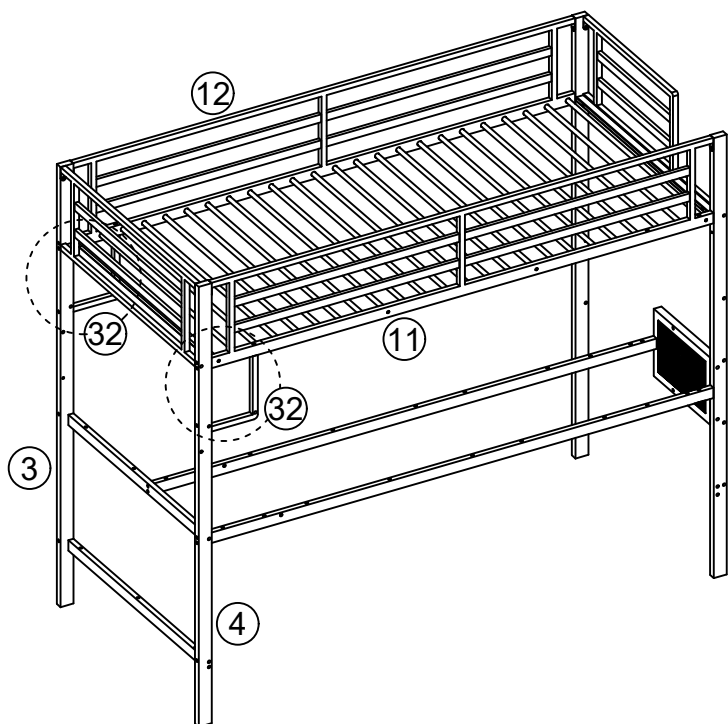

M5

(W) × 1PC



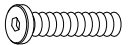

13

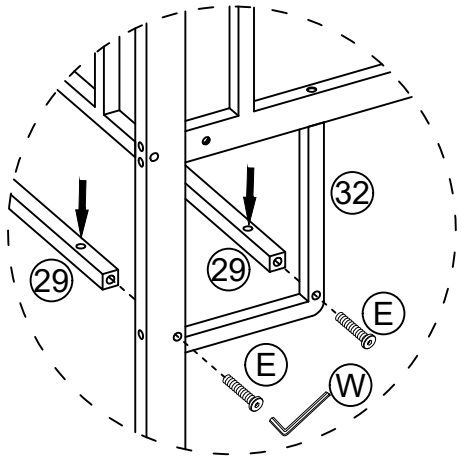
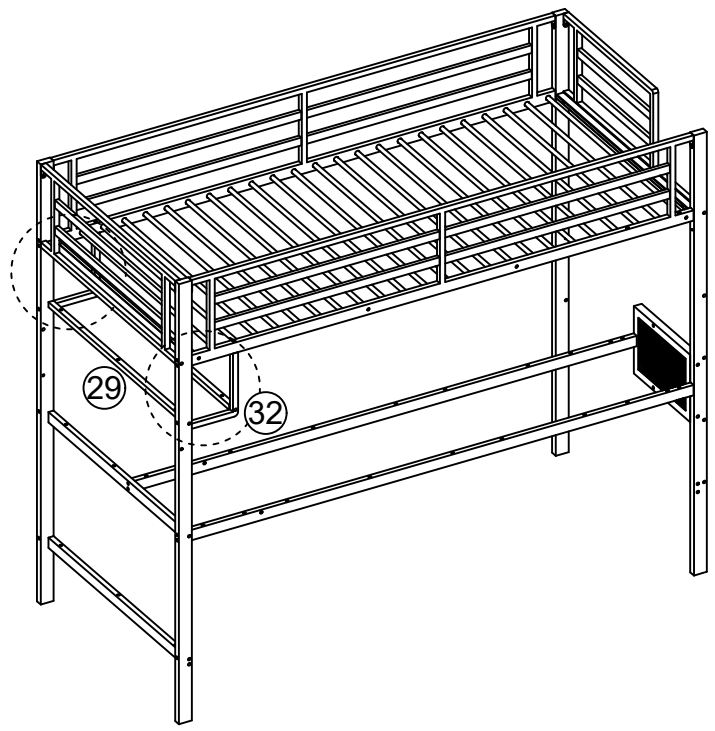
 M8×40mm	 M5
(E)×4PCS	(W)×1PC

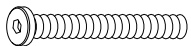

14

 M8*70mm	 M8×20mm	 M5
(A)×1PC	(G)×2PCS	(W)×1PC

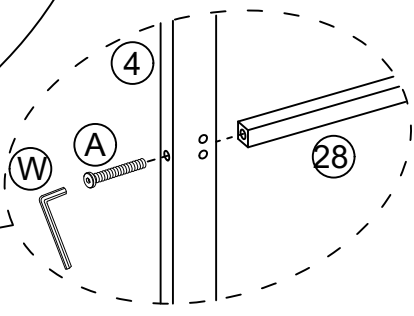
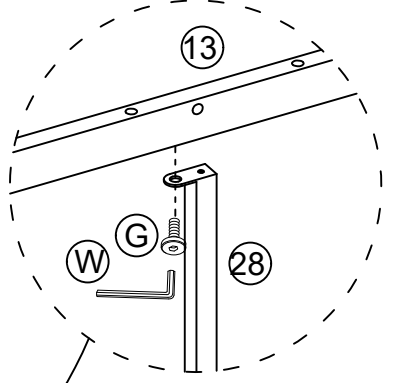
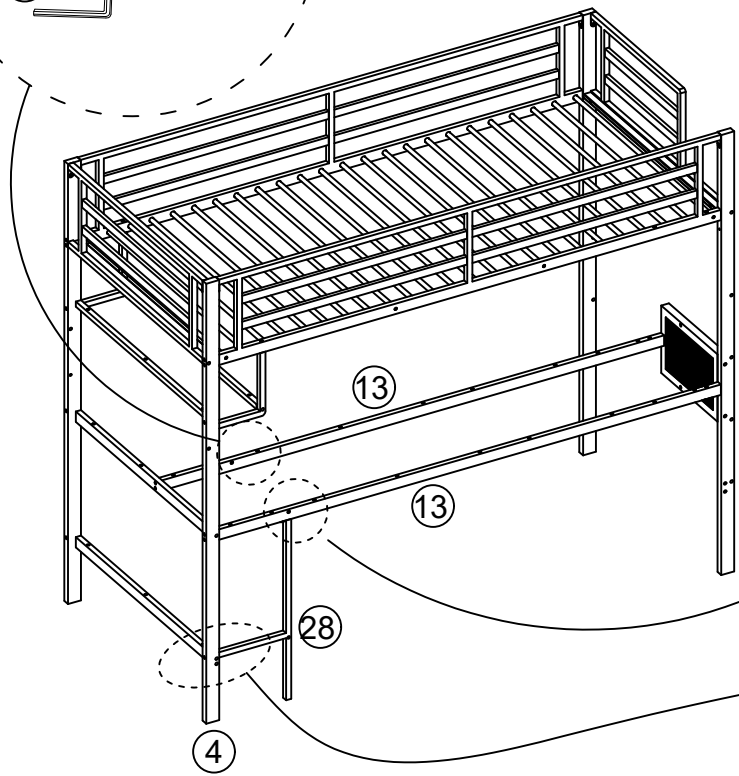
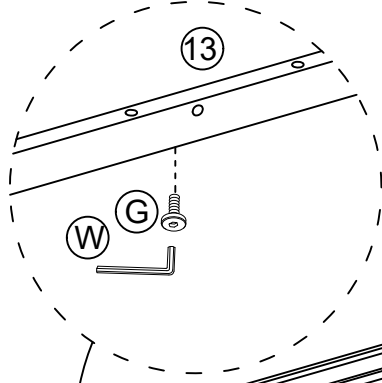

15

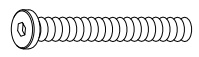

M8*70mm

(A) x 2PCS



M5

(W) x 1PC

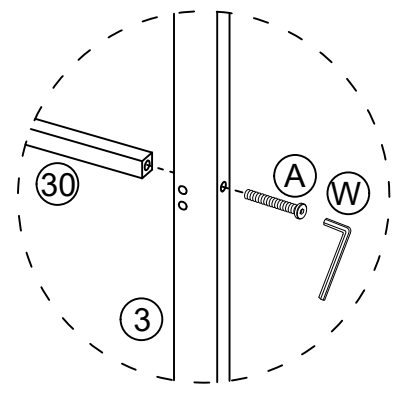
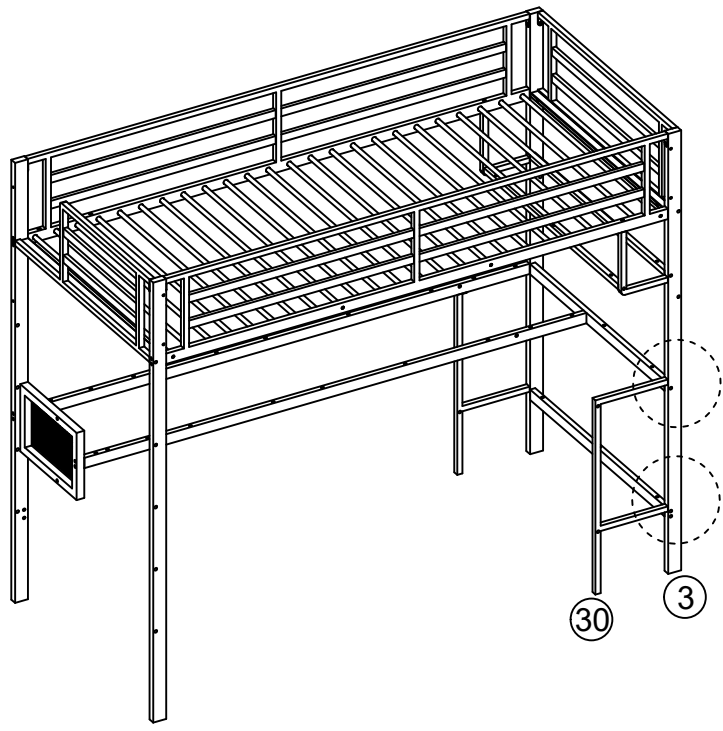

16



M8x35mm

(F) x 4PCS



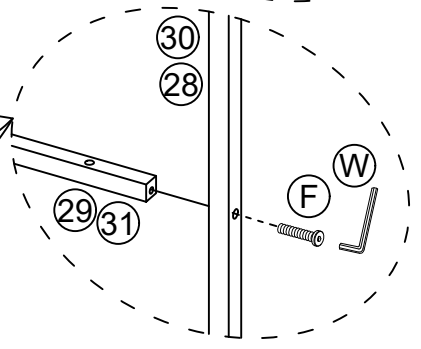
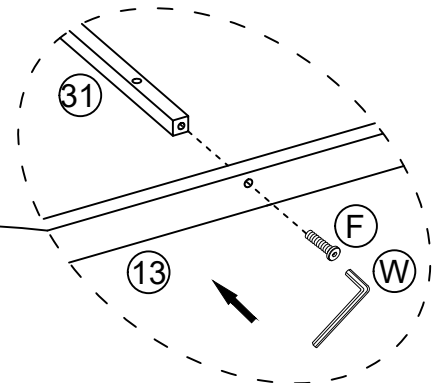
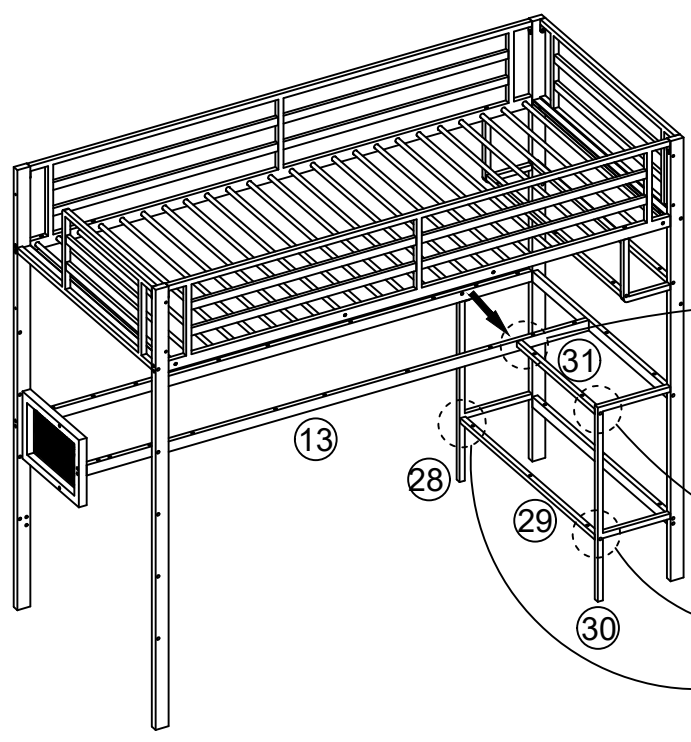

M5

(W) x 1PC



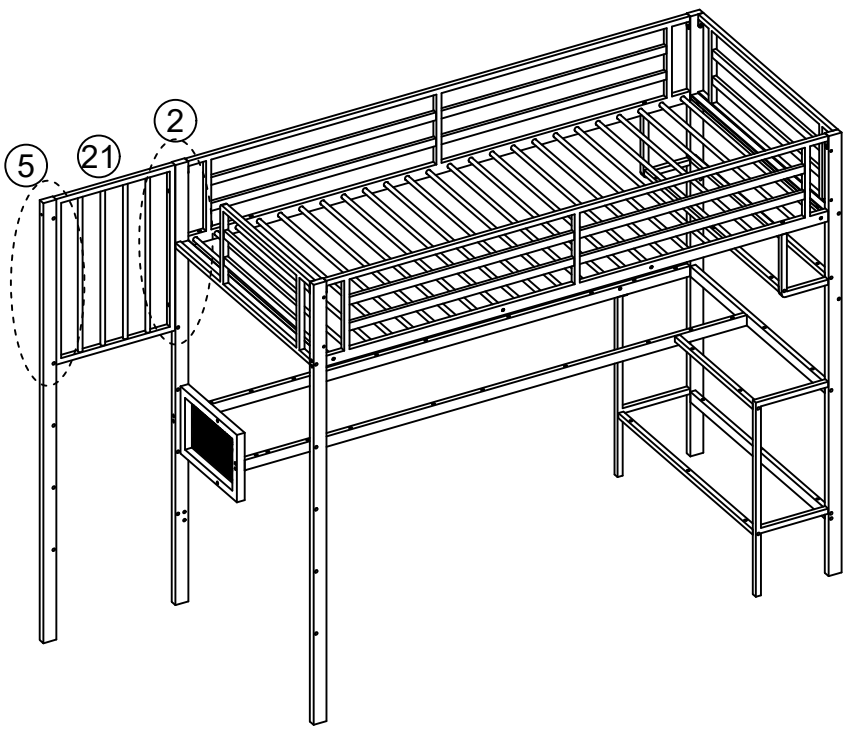
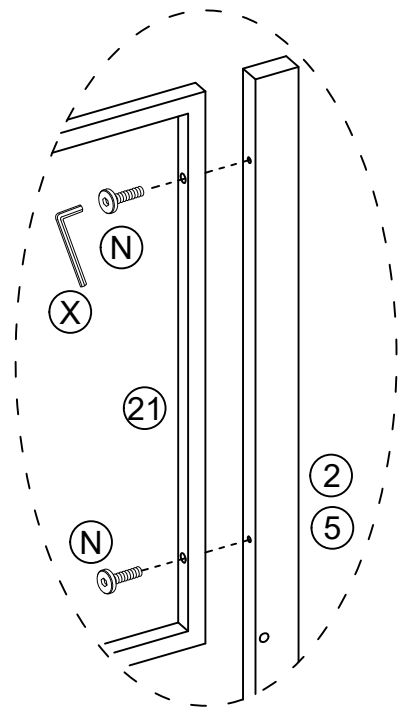

17

 M6×30mm	 M4
(N)×4PCS	(X)×1PC



18

 M6×30mm	 M4
(N)×6PCS	(X)×1PC

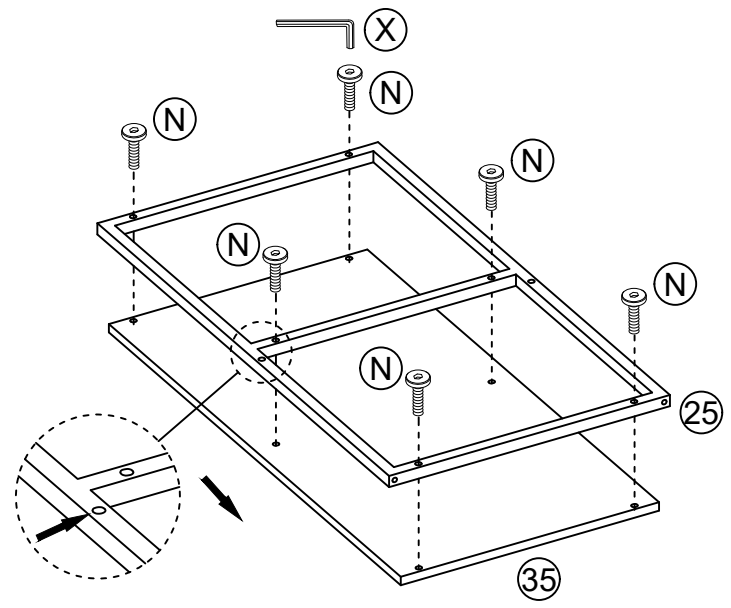

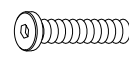
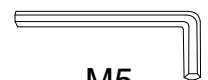

19

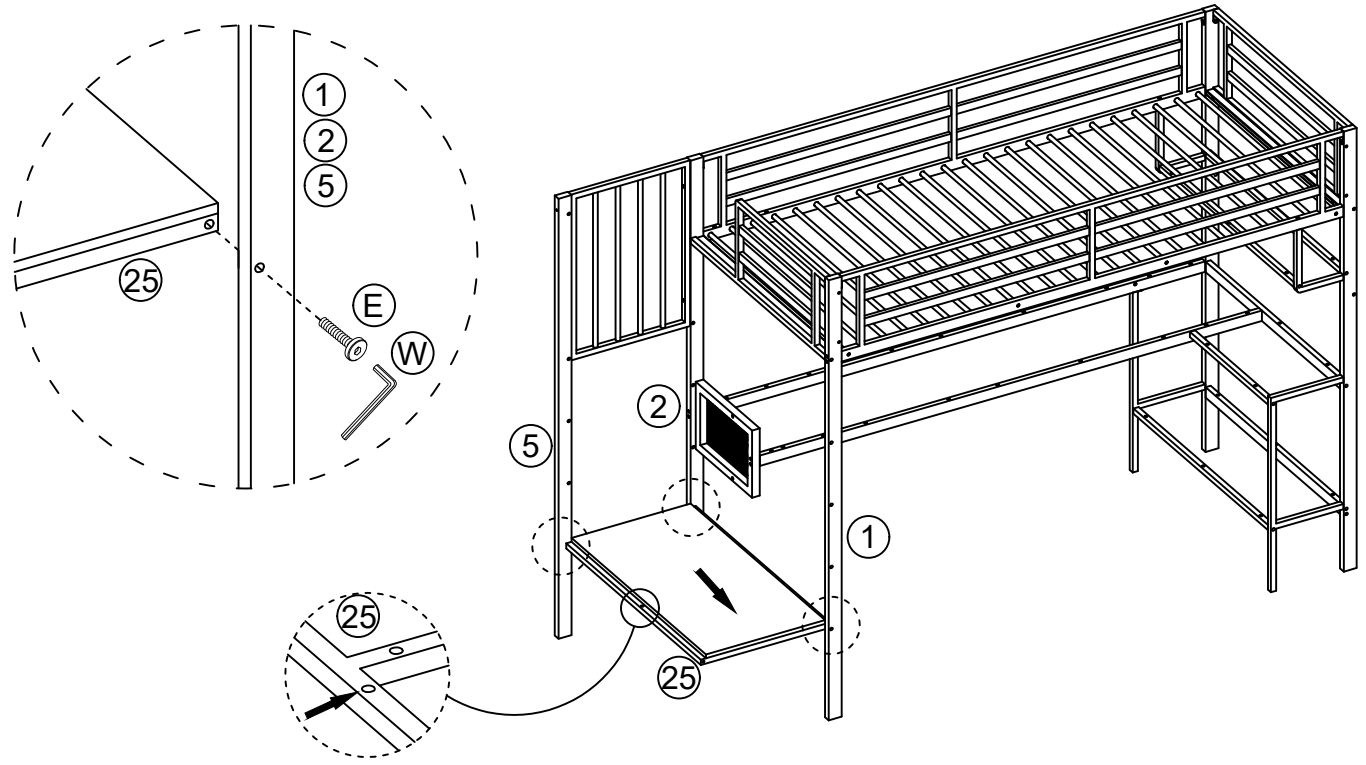
 M8×40mm	 M5
(E) × 3PCS	(W) × 1PC



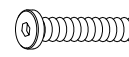

20

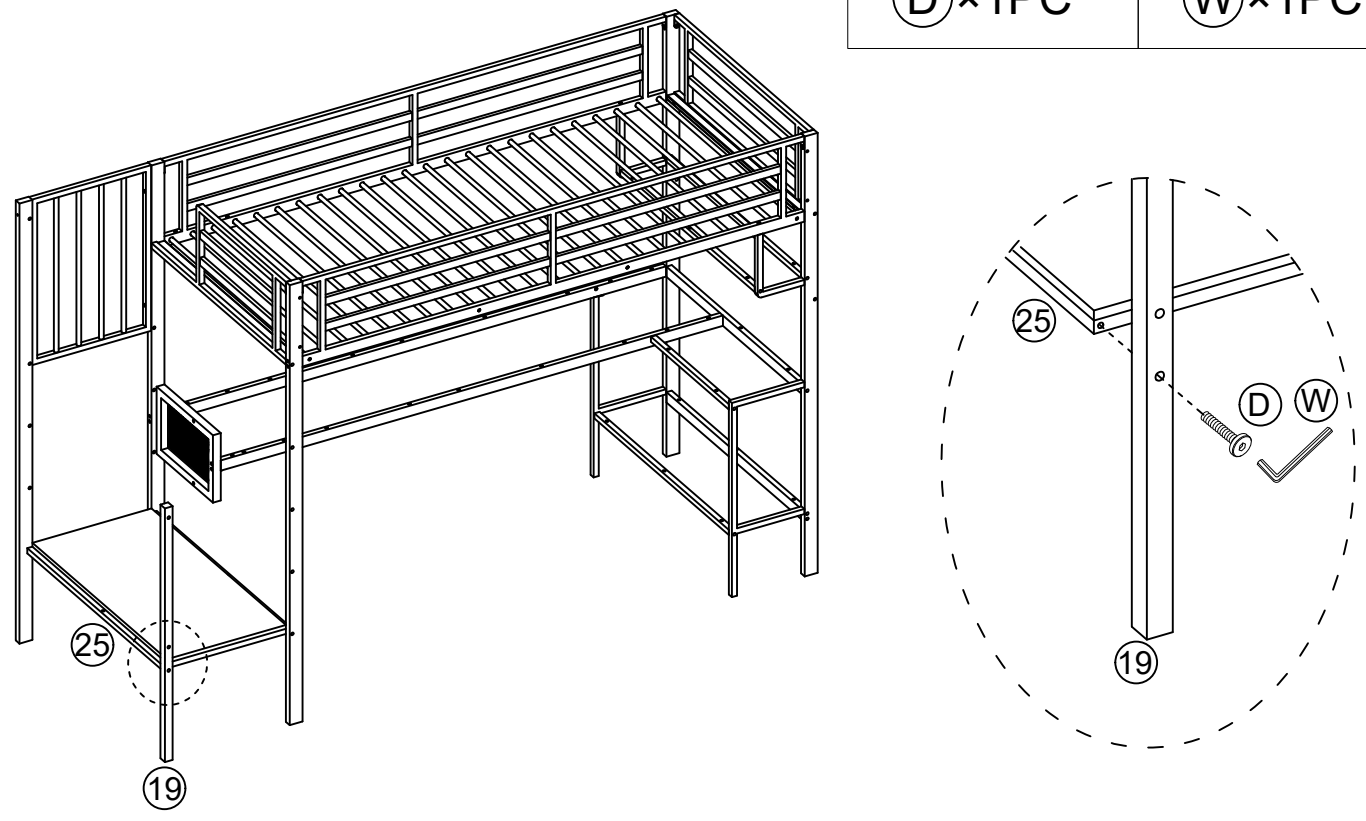
 M8×45mm	 M5
(D) × 1PC	(W) × 1PC



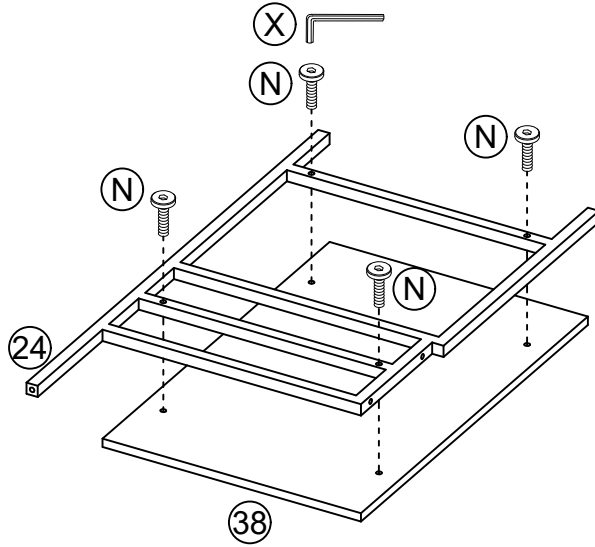

21

 M6×30mm	 M4
(N)×4PCS	(X)×1PC



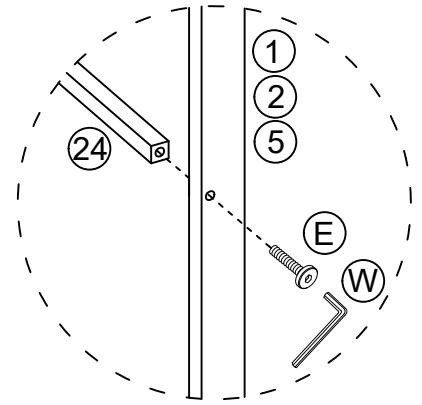
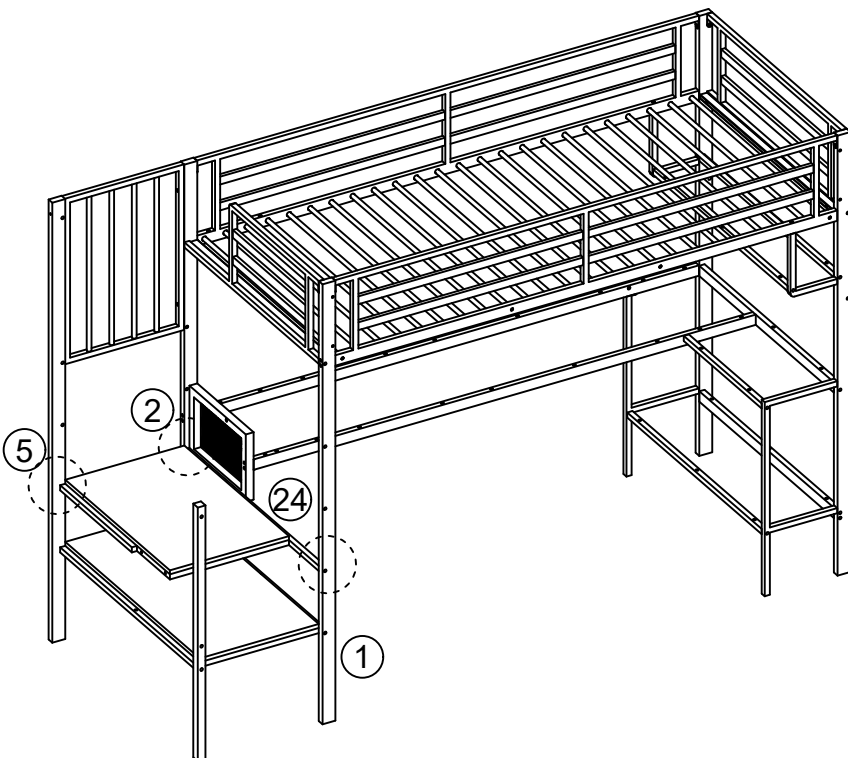

22

 M8×40mm	 M5
(E)×3PCS	(W)×1PC



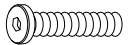

23

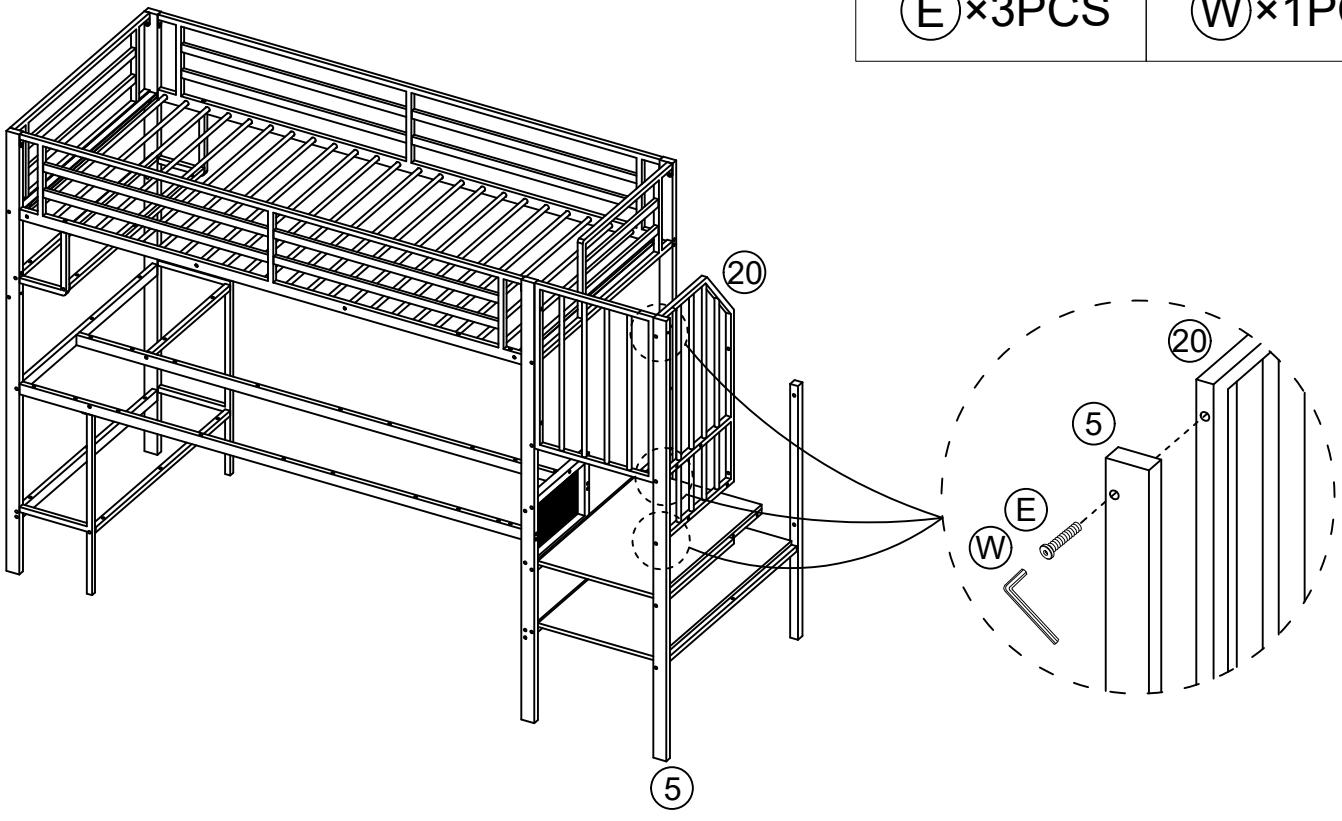
 M8×40mm	 M5
(E) × 3PCS	(W) × 1PC



24

 M6×30mm	 M4
(N) × 8PCS	(X) × 1PC

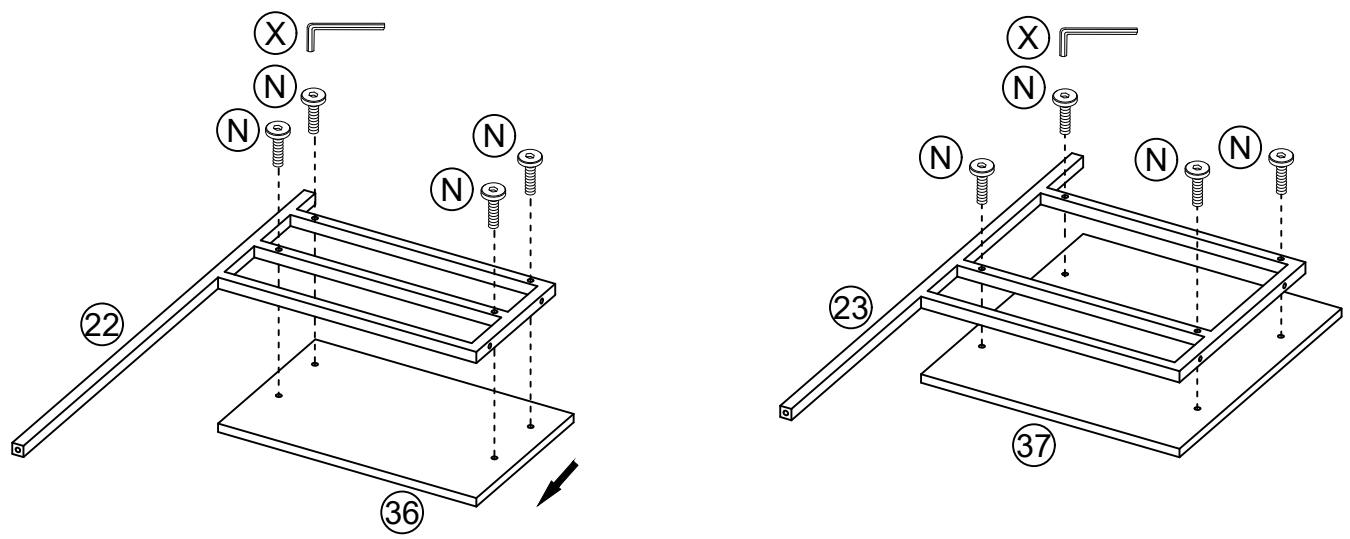
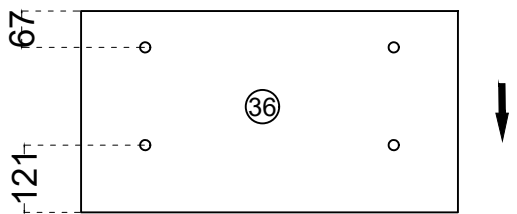

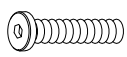
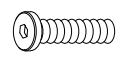
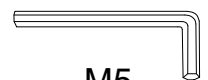

25

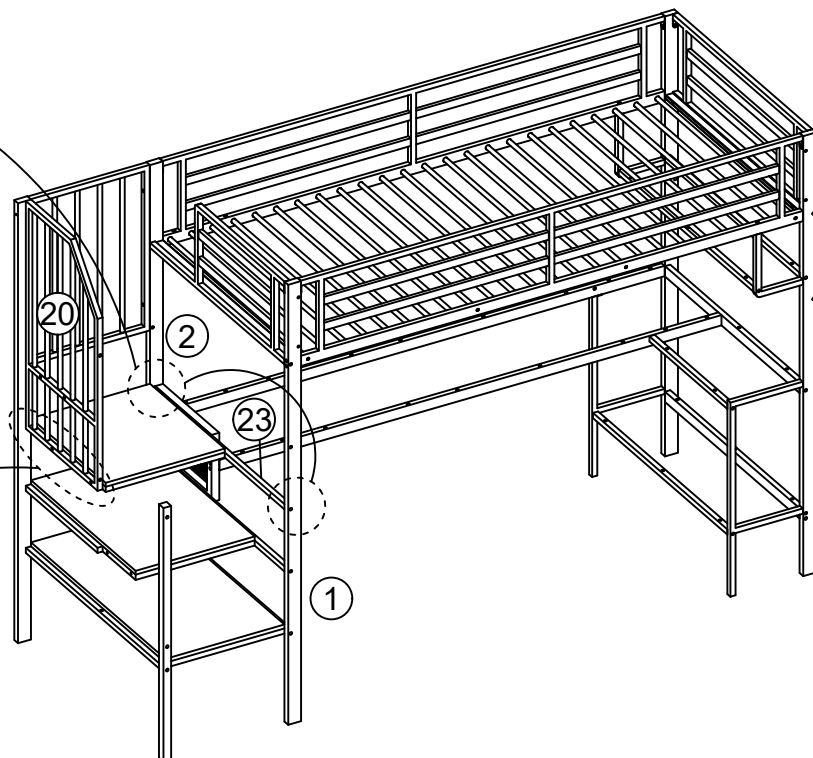
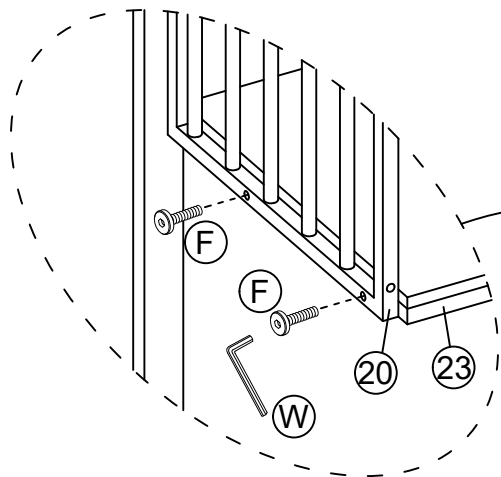
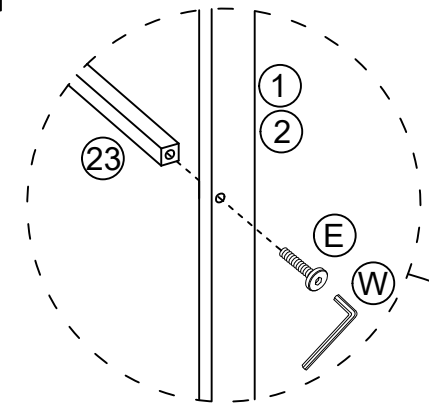
		
M8×40mm	M8×35mm	M5
(E) × 2PCS	(F) × 2PCS	(W) × 1PC

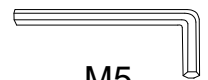

26

		
M8×40mm	M8×35mm	M5
(E) × 2PCS	(F) × 2PCS	(W) × 1PC

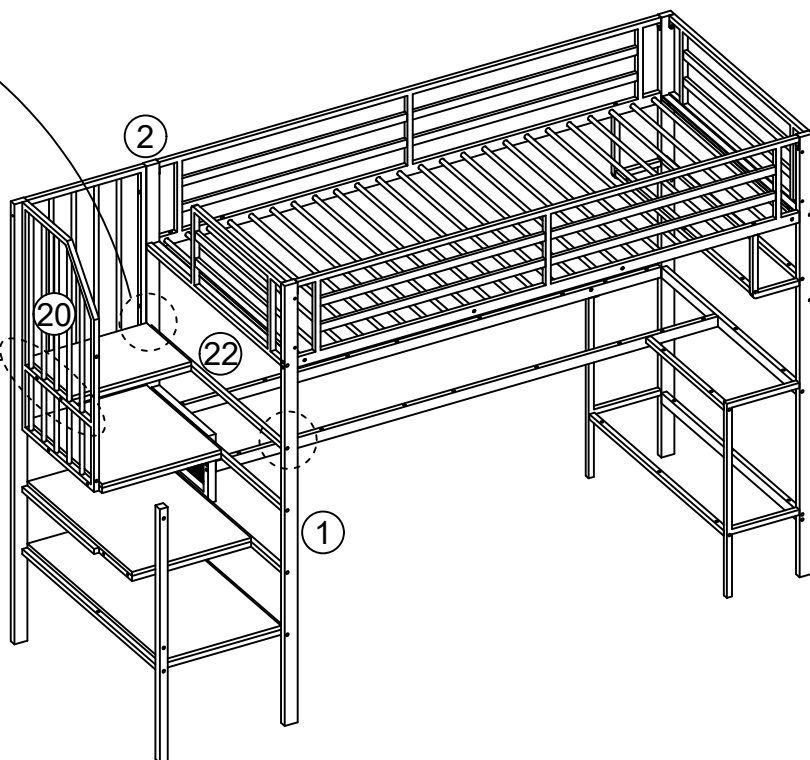
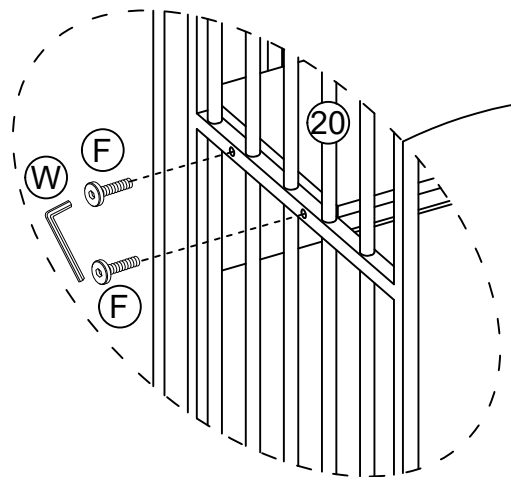
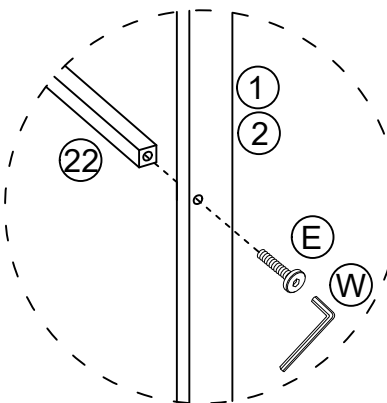

27



M6×30mm

(N)×2PCS



M6×17mm

(R)×2PCS



M4

(X)×2PCS

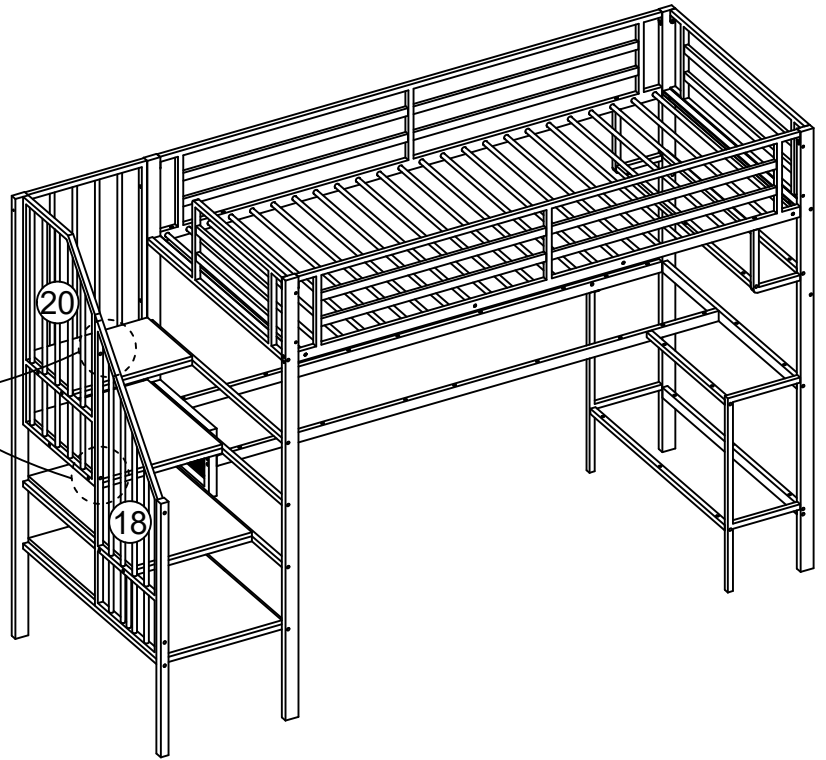
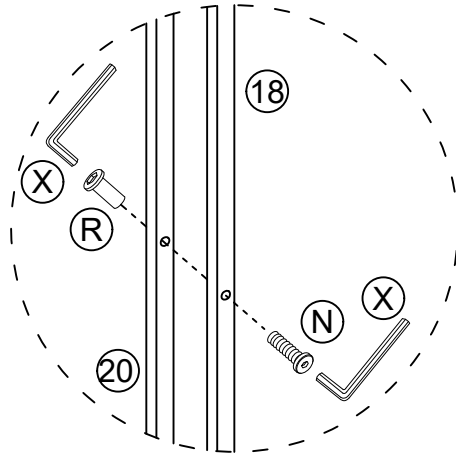

28

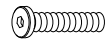

M6×40mm

(M)×2PCS



M6×17mm

(R)×2PCS



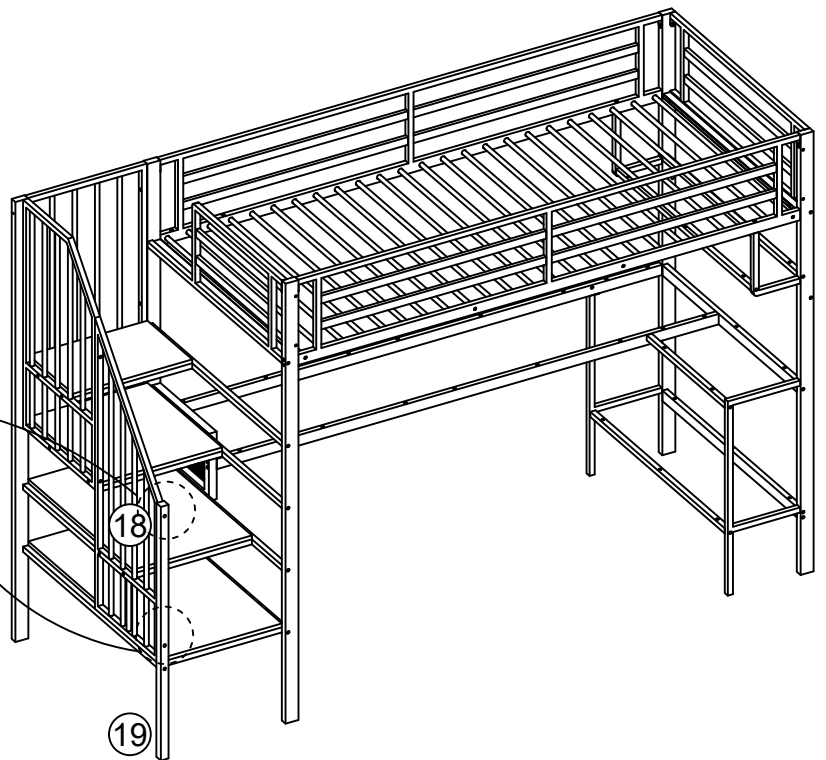
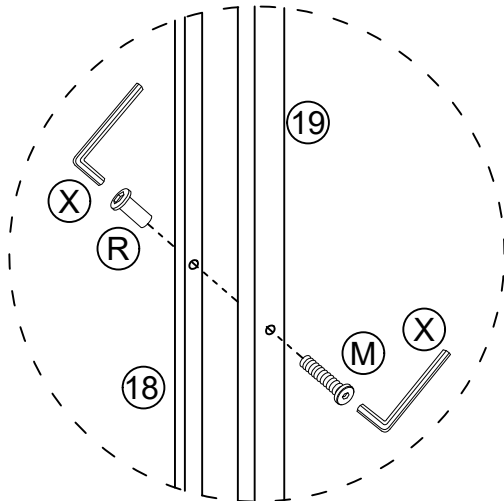

M4

(X)×2PCS



29

 M8×35mm	 M5
F × 2PCS	W × 1PC

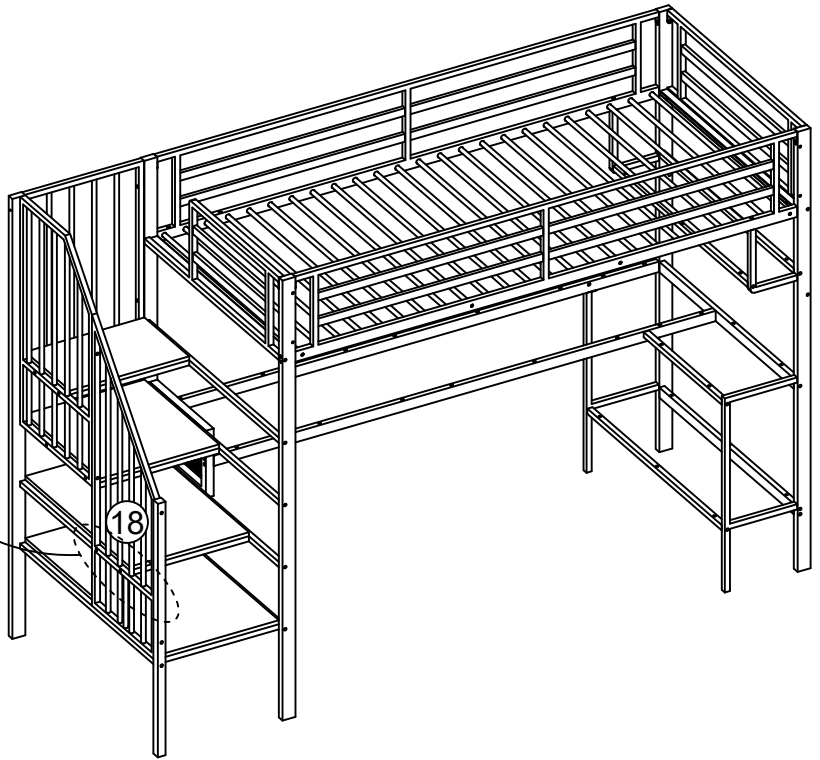
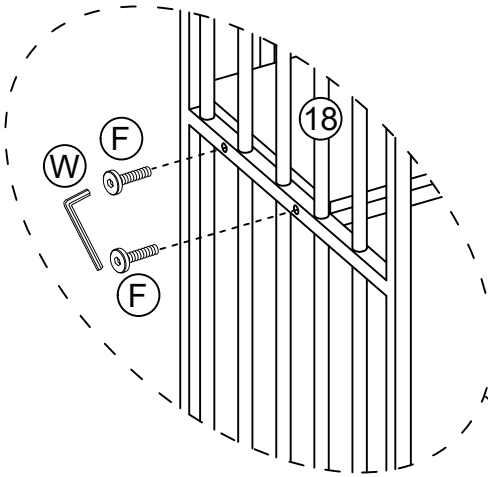

30

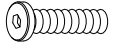
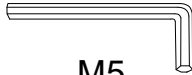
 M8×35mm	 M5
F × 1PC	W × 1PC

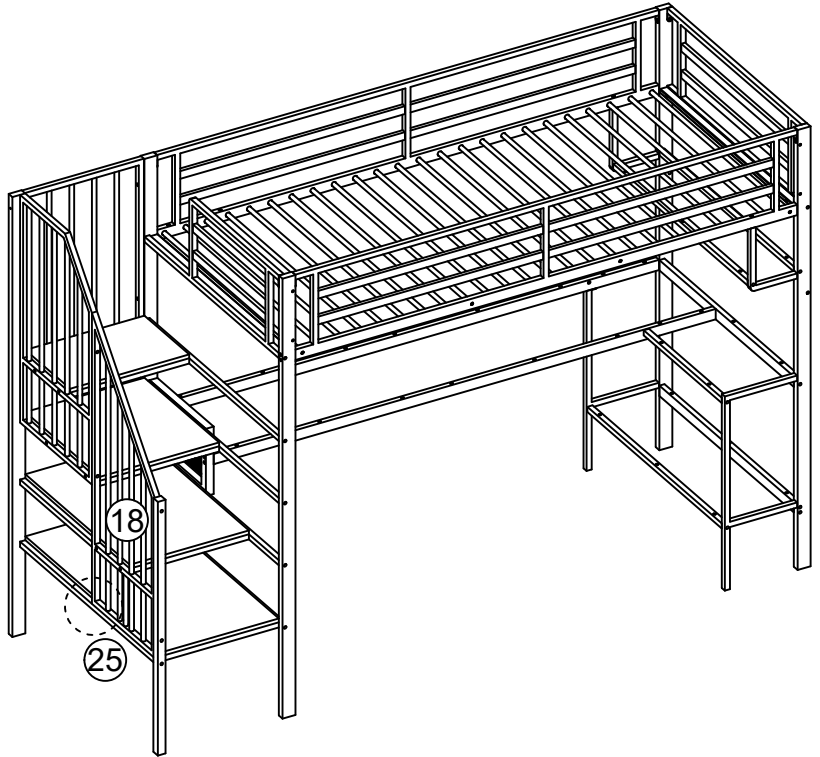
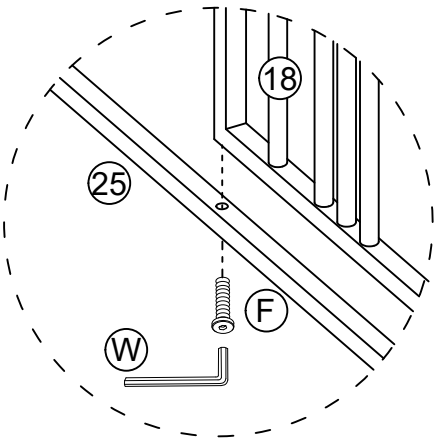

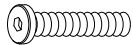
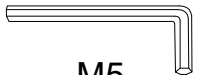

31

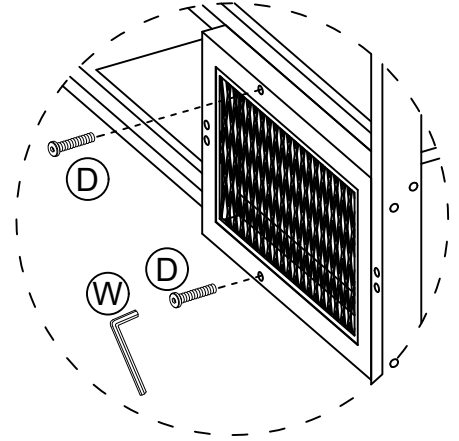
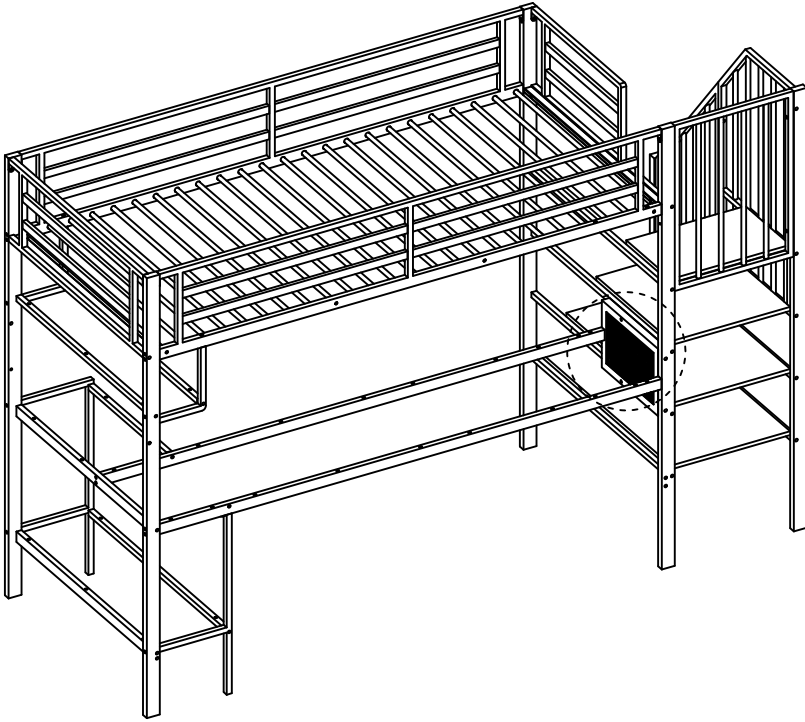
 M8×45mm	 M5
(D)×2PCS	(W)×1PC

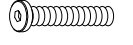

32

 M6×48mm	 M4
(L)×12PCS	(X)×1PC

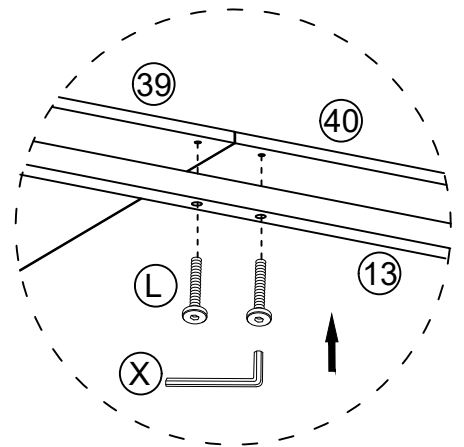
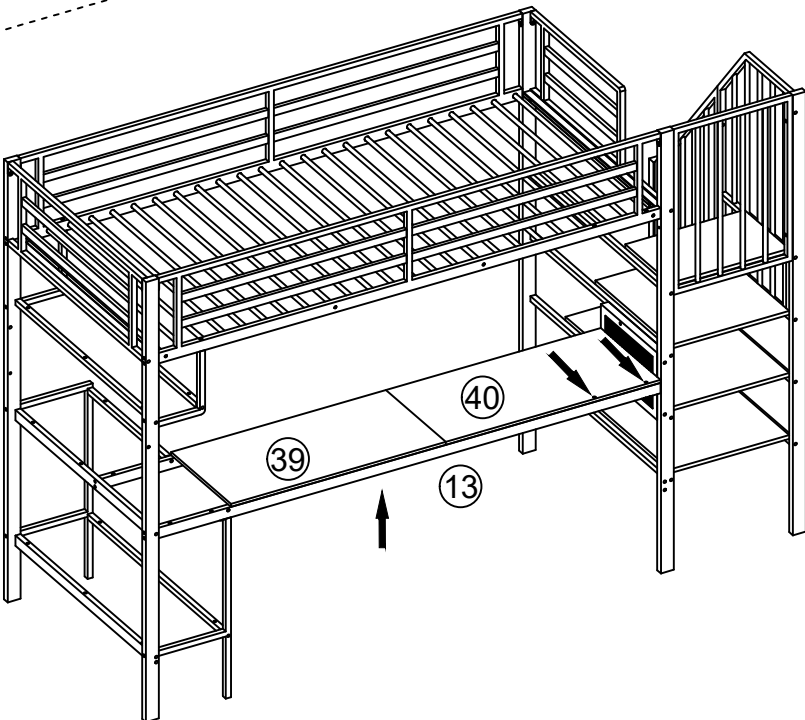
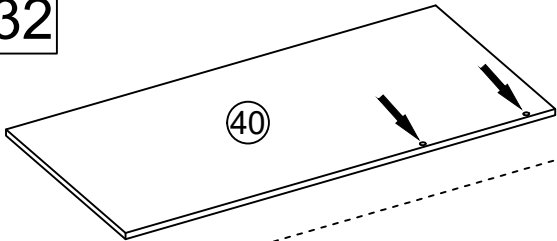

33



M6×48mm

(L) × 6PCS

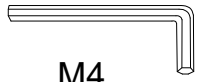

M4

(X) × 1PC

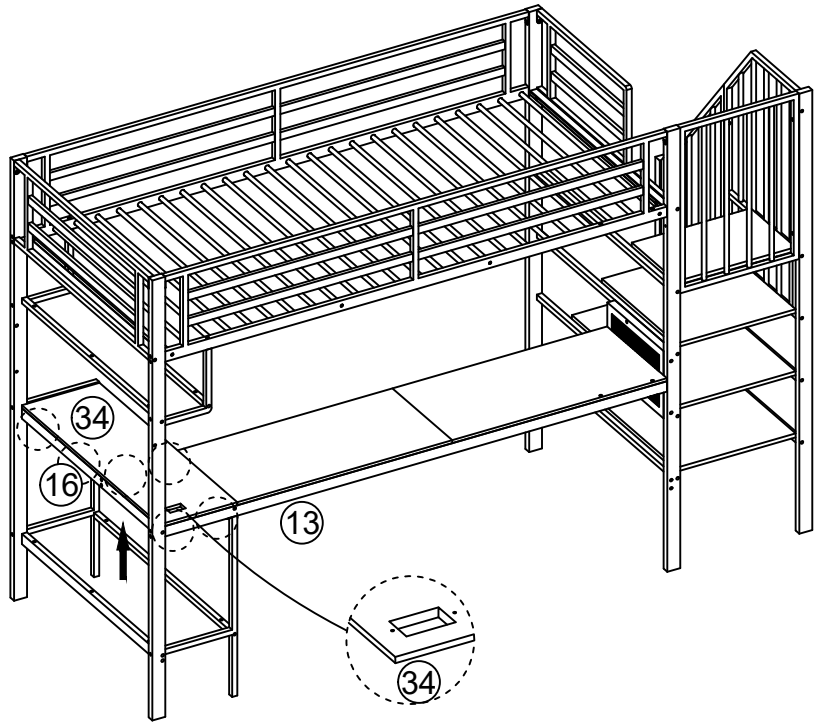
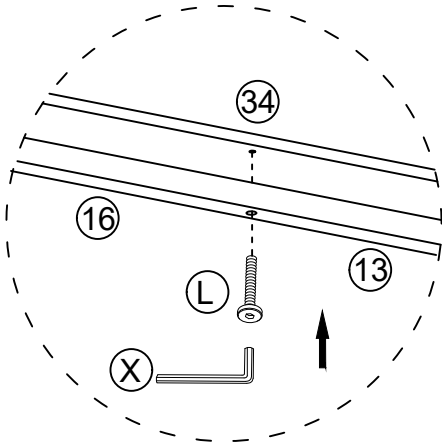

34

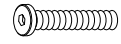

M6×48mm

(L) × 3PCS



M4

(X) × 1PC

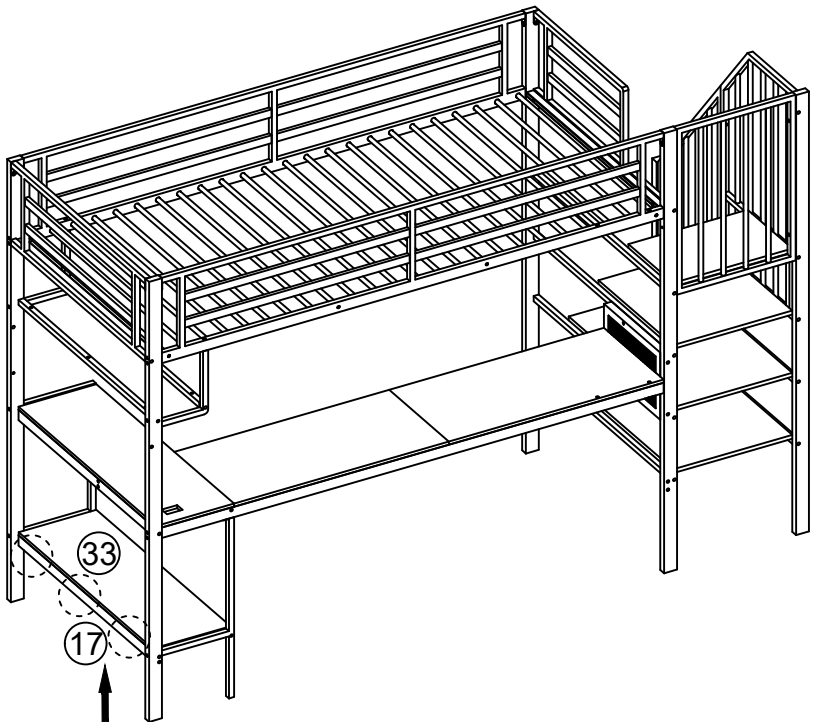
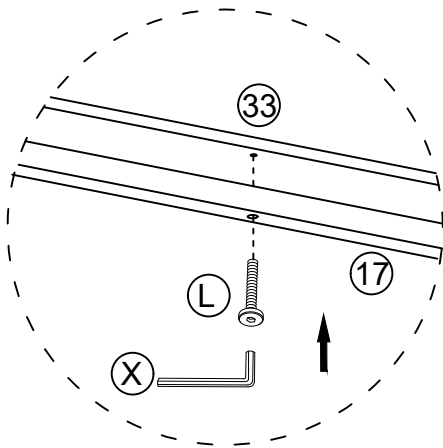

35



M6×30mm

(N)×5PCS

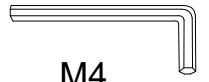

M4

(X)×1PC

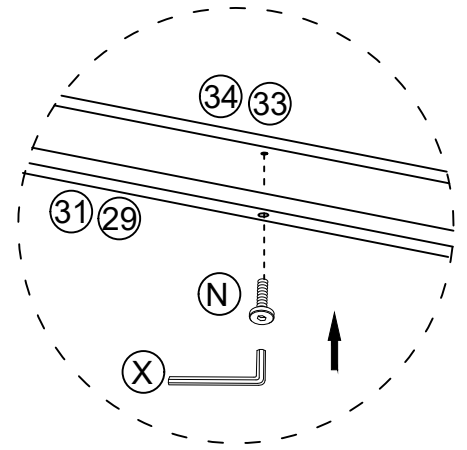
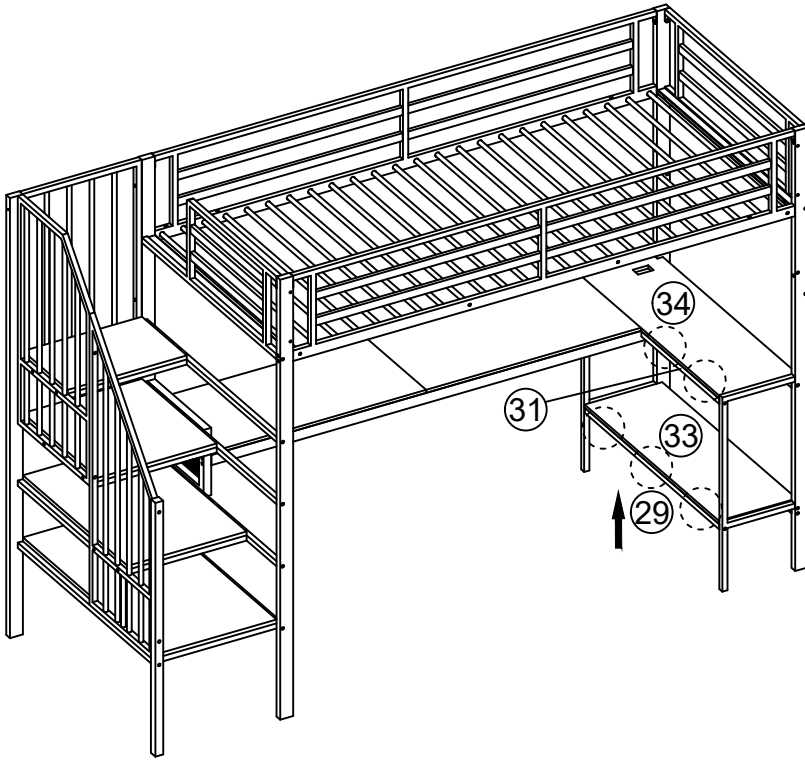

36



M4×30mm

(P)×6PCS



(V)×1PC

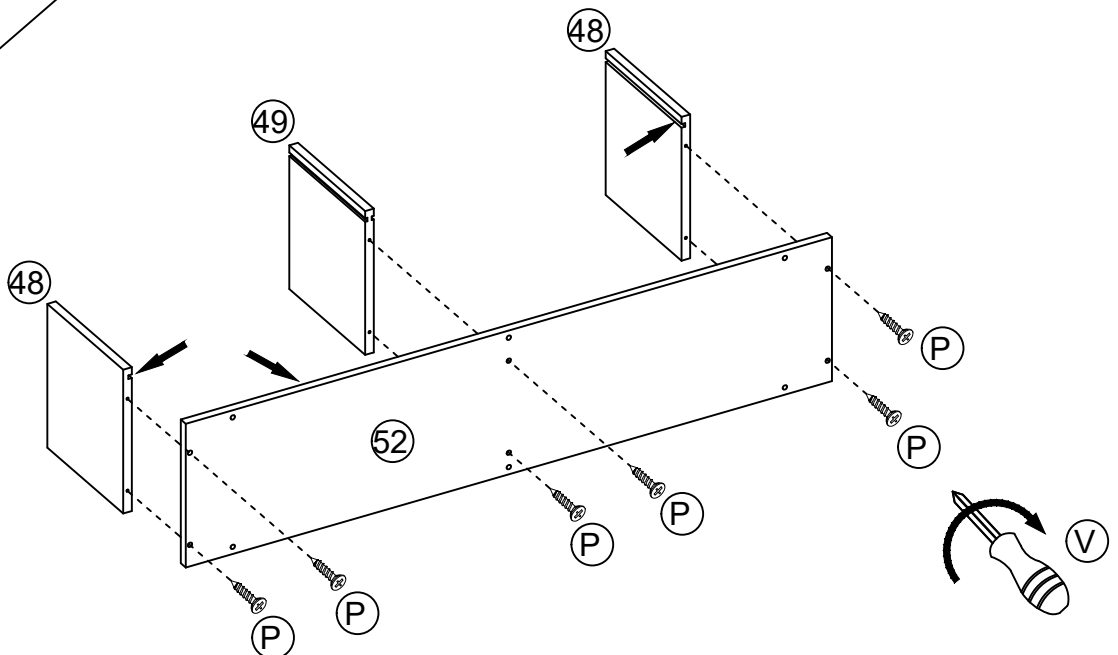
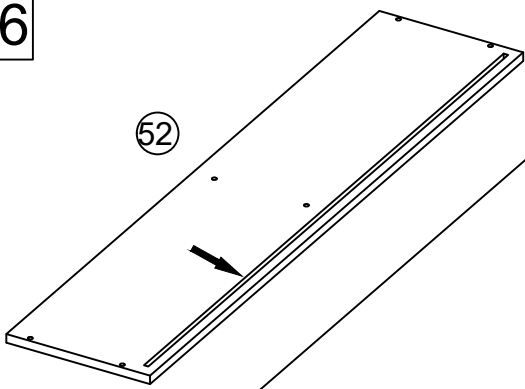

37

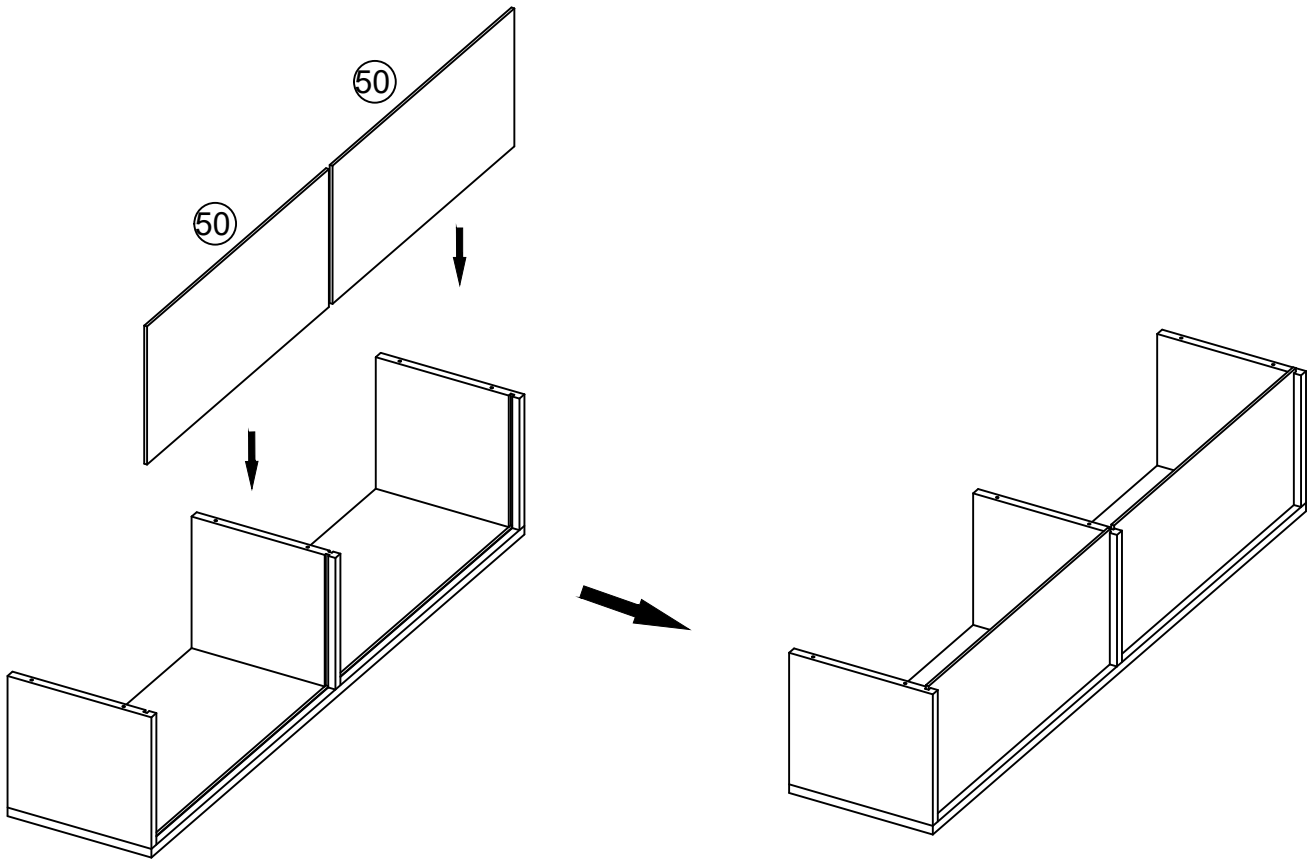

38

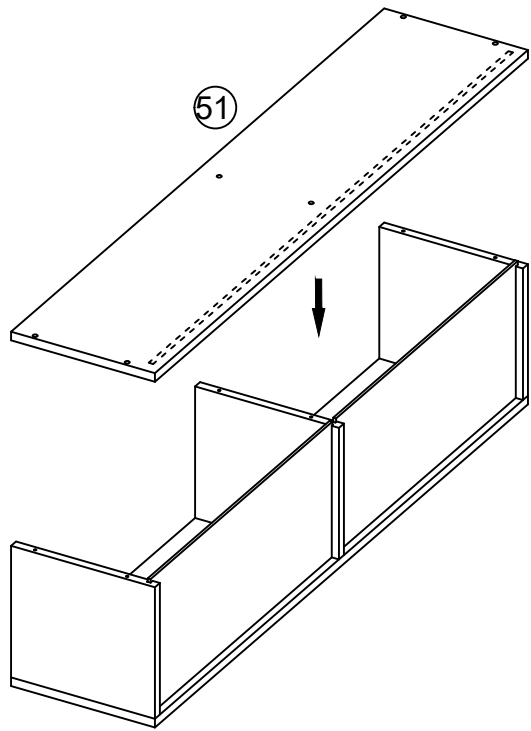

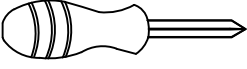

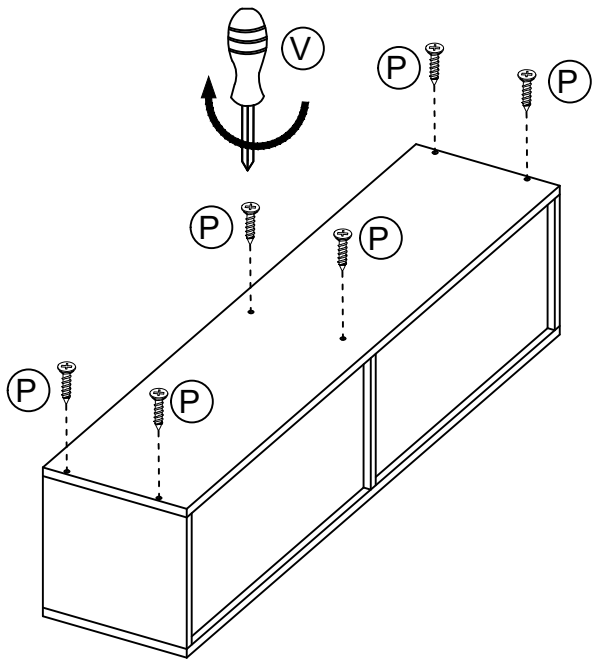
 M4×30mm	
(P) × 6PCS	(V) × 1PC

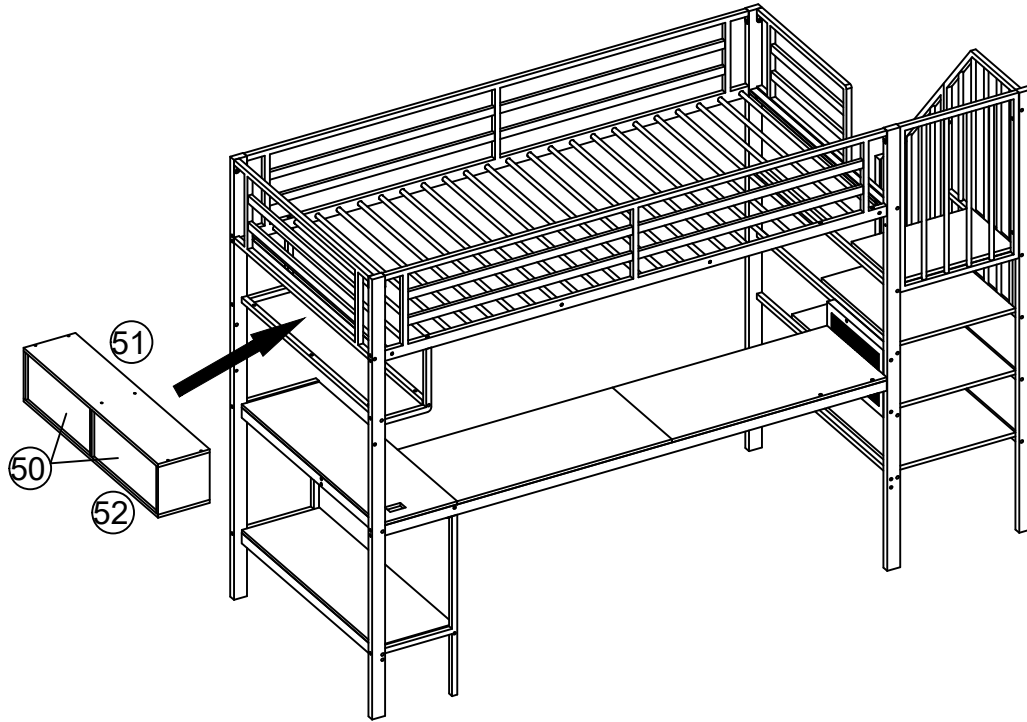

39



40

 M6×30mm	 M4
(N) × 6PCS	(X) × 1PC

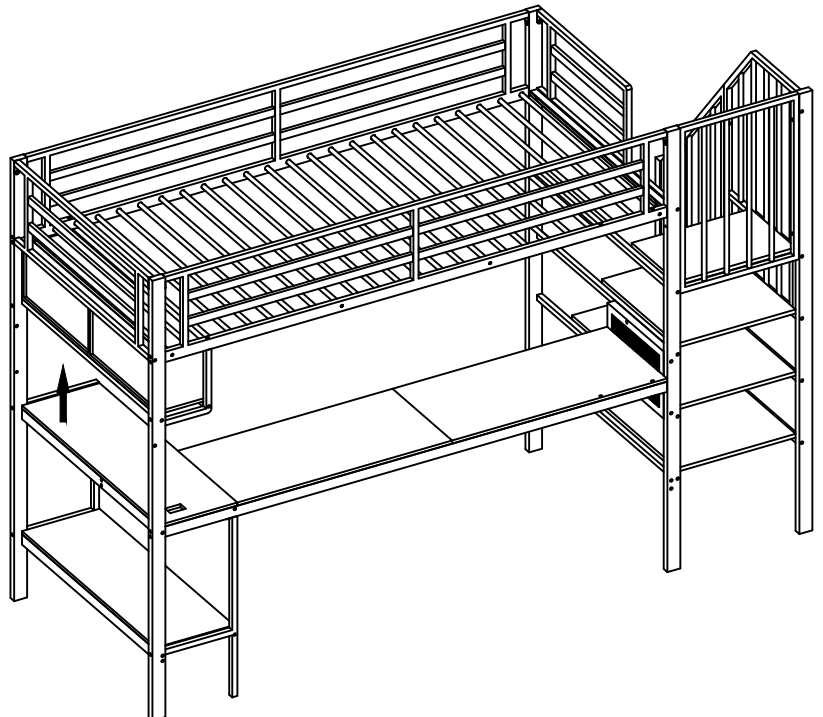
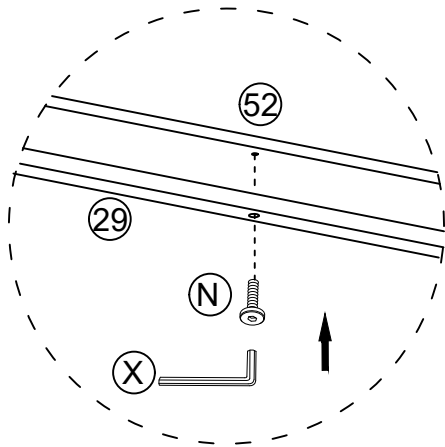

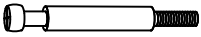
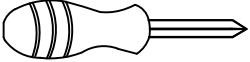
	
(S) × 11 PCS	(V) × 1 PC

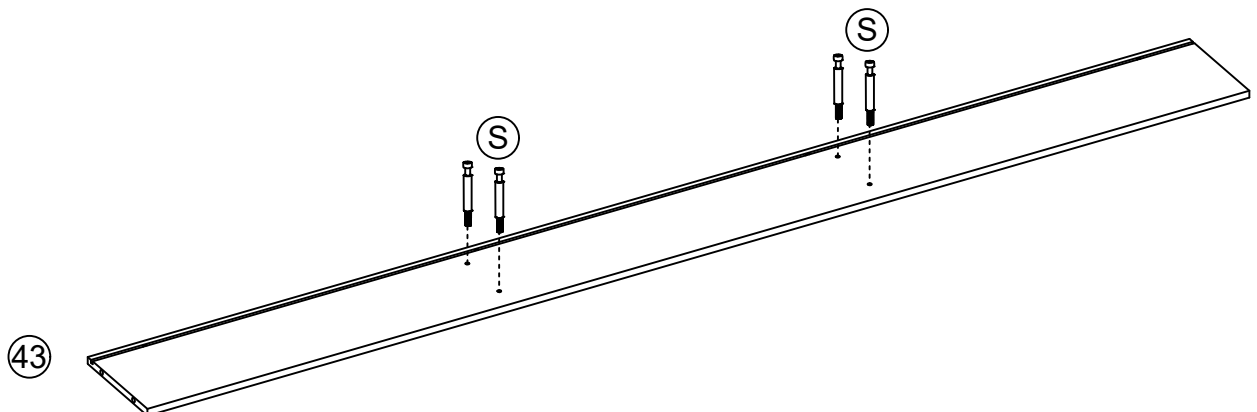
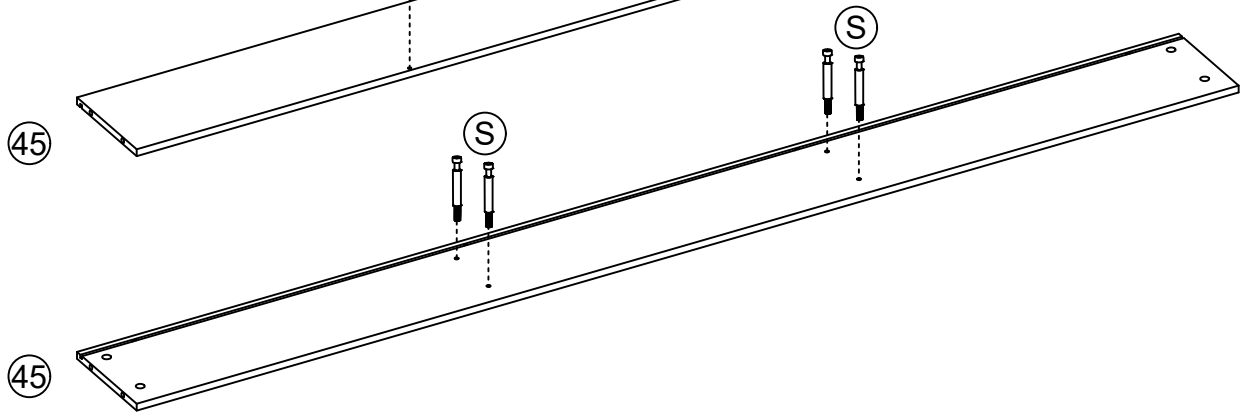
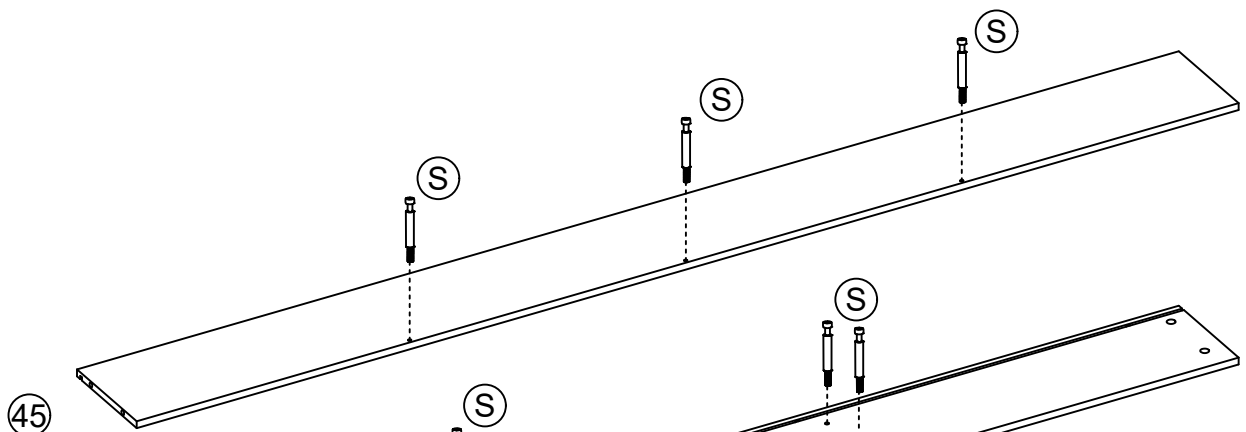
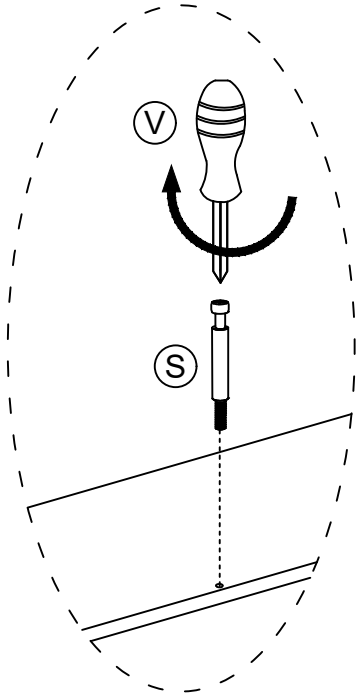

42

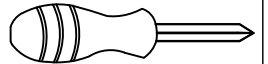
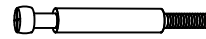
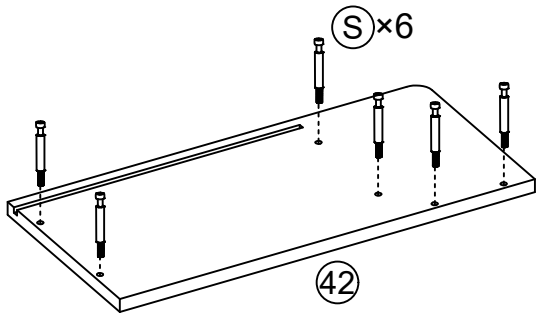
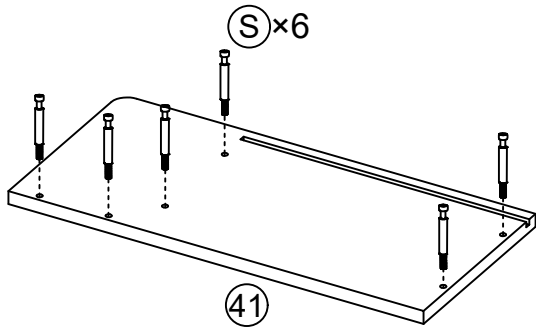

S x 12PCS

V x 1PC

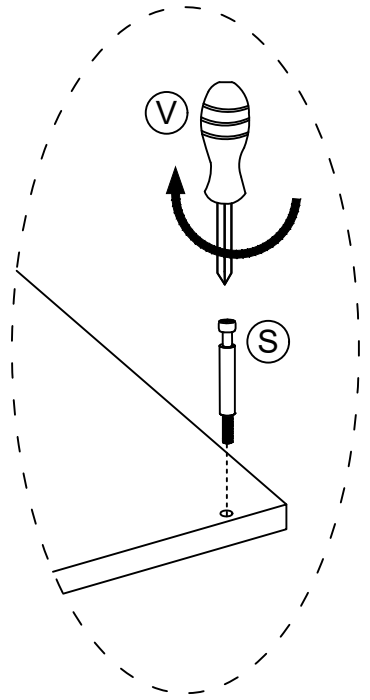

43

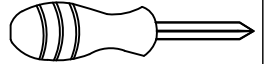
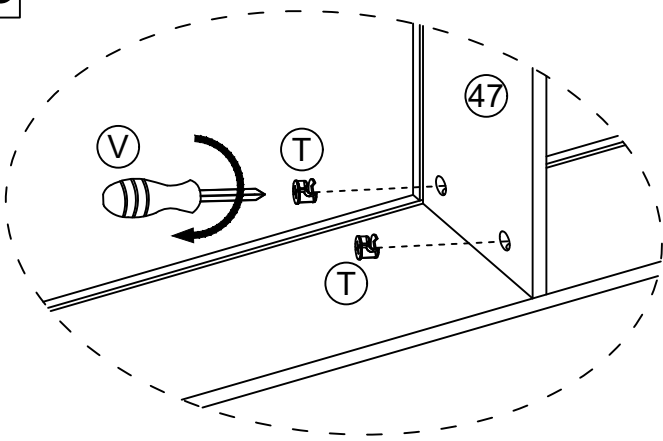

T x 4PCS

V x 1PC

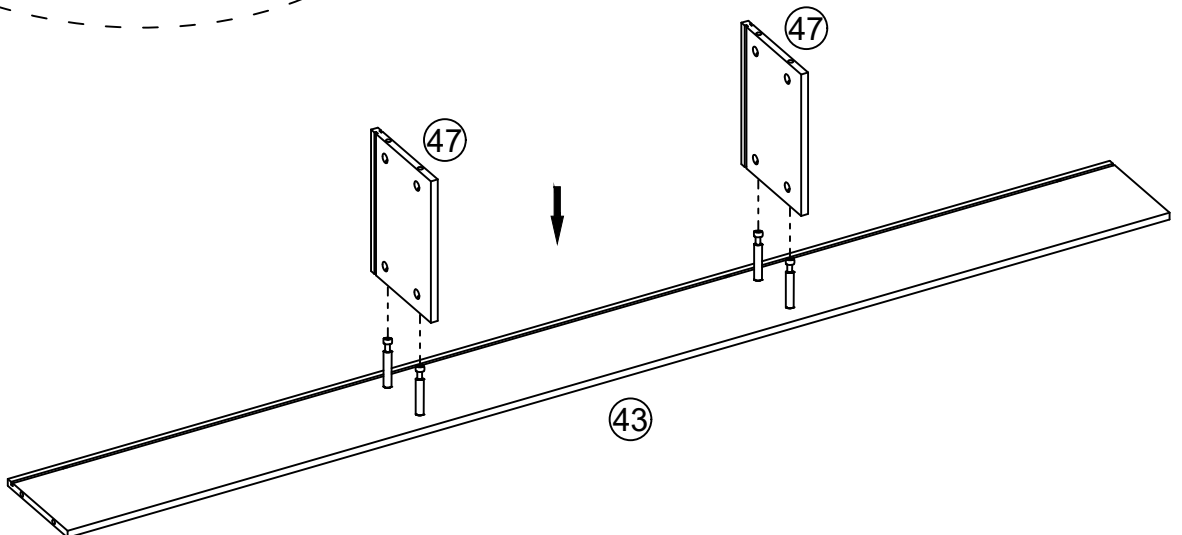

44

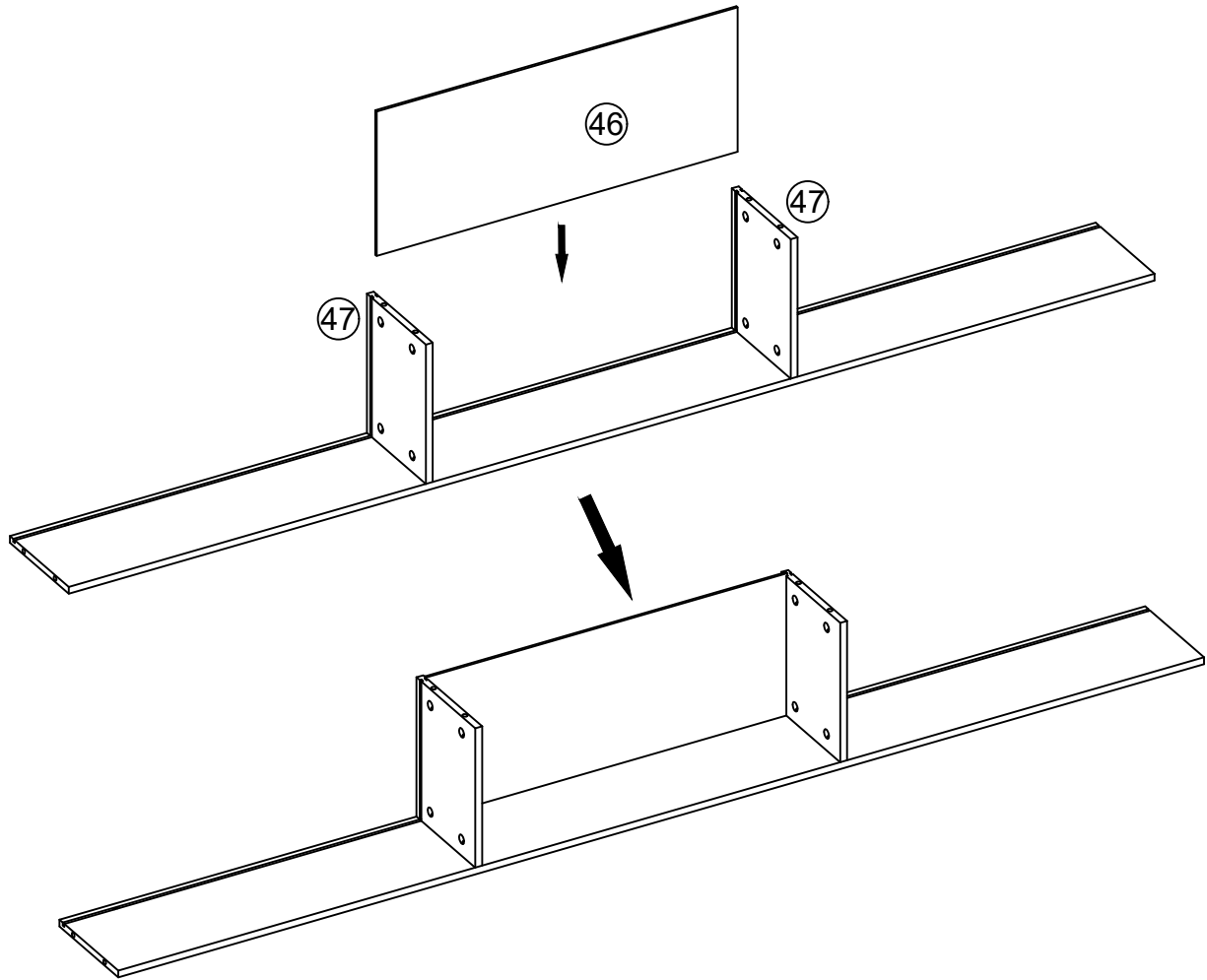

45

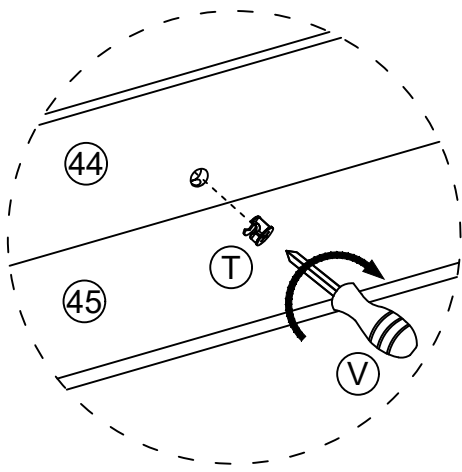

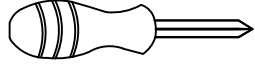
	
(T) × 3PCS	(V) × 1PC

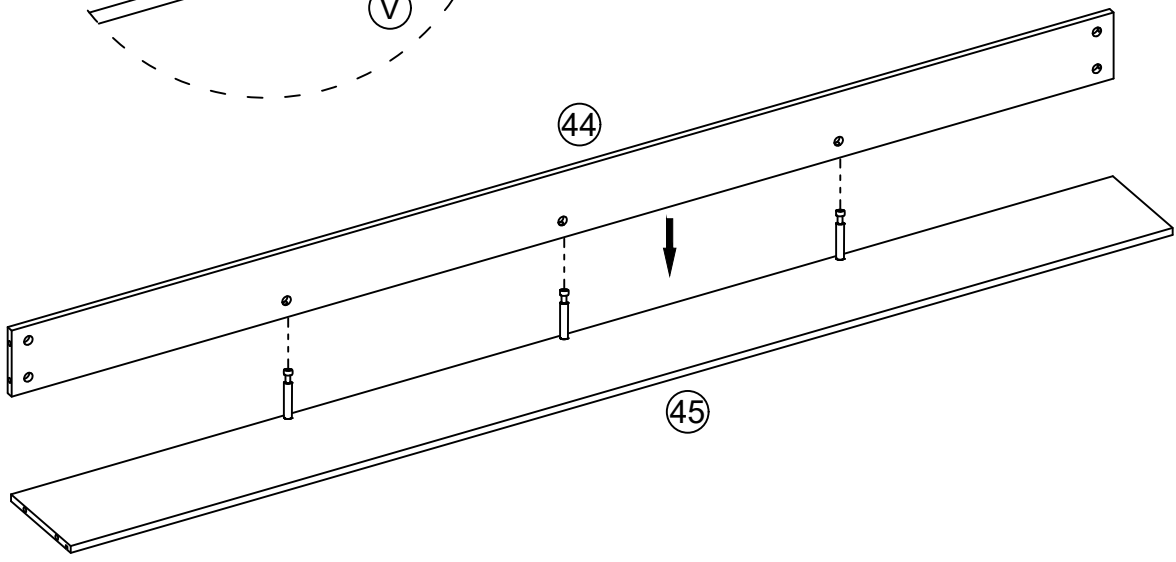

46

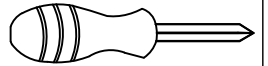

(T) × 4PCS

(V) × 1PC

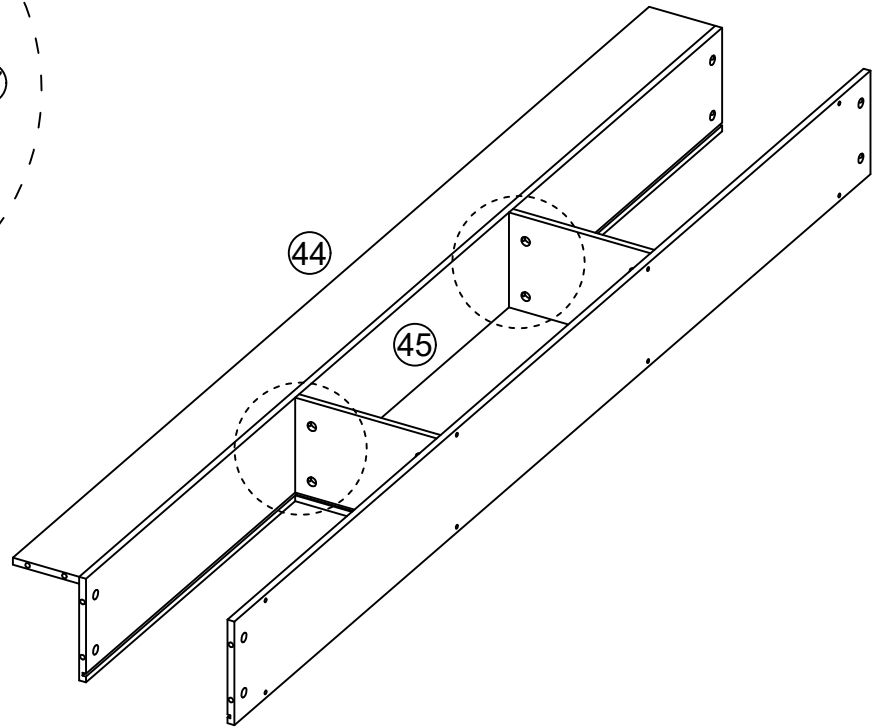
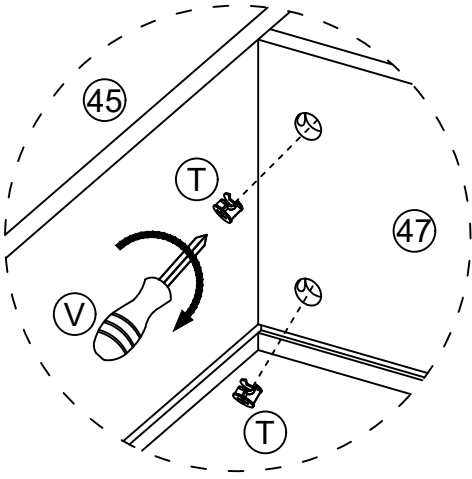

47

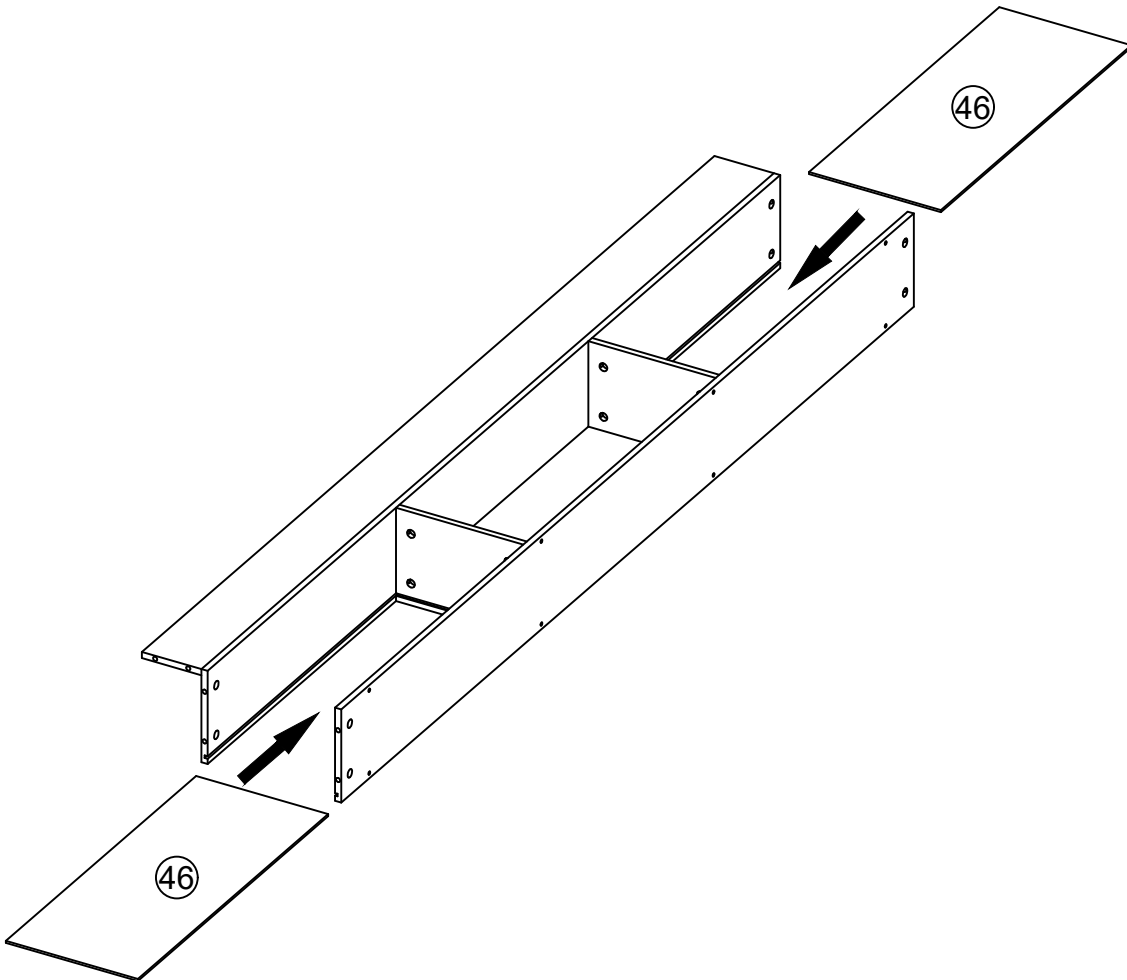

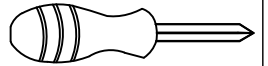

(T) × 8PCS

(V) × 1PC

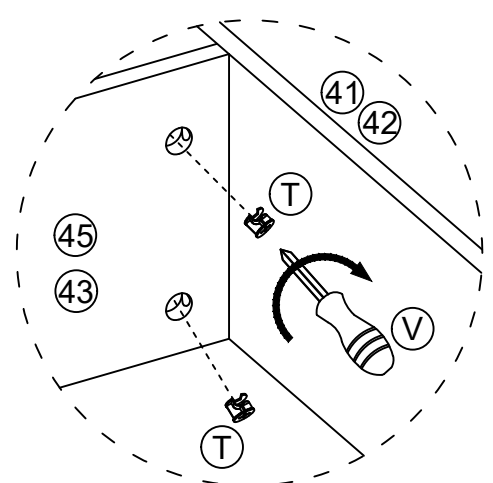
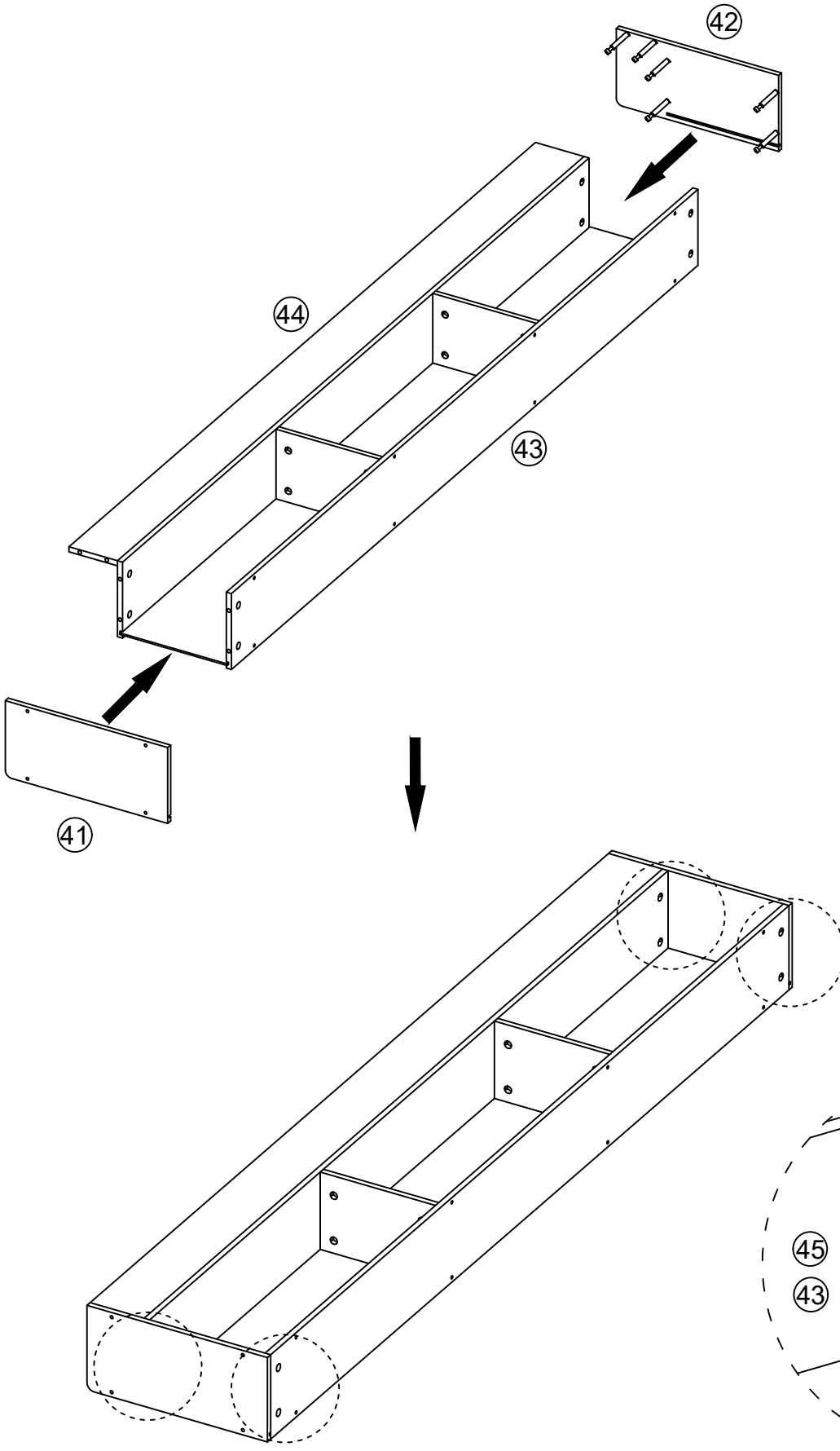

49

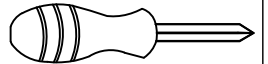
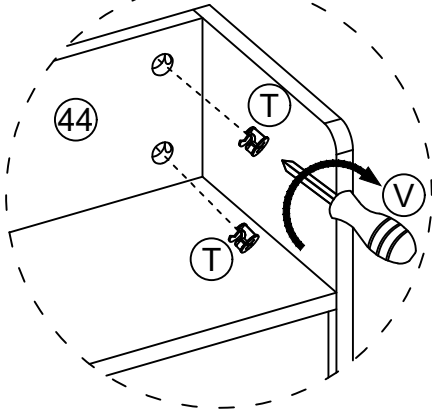

(T) × 4PCS

(V) × 1PC

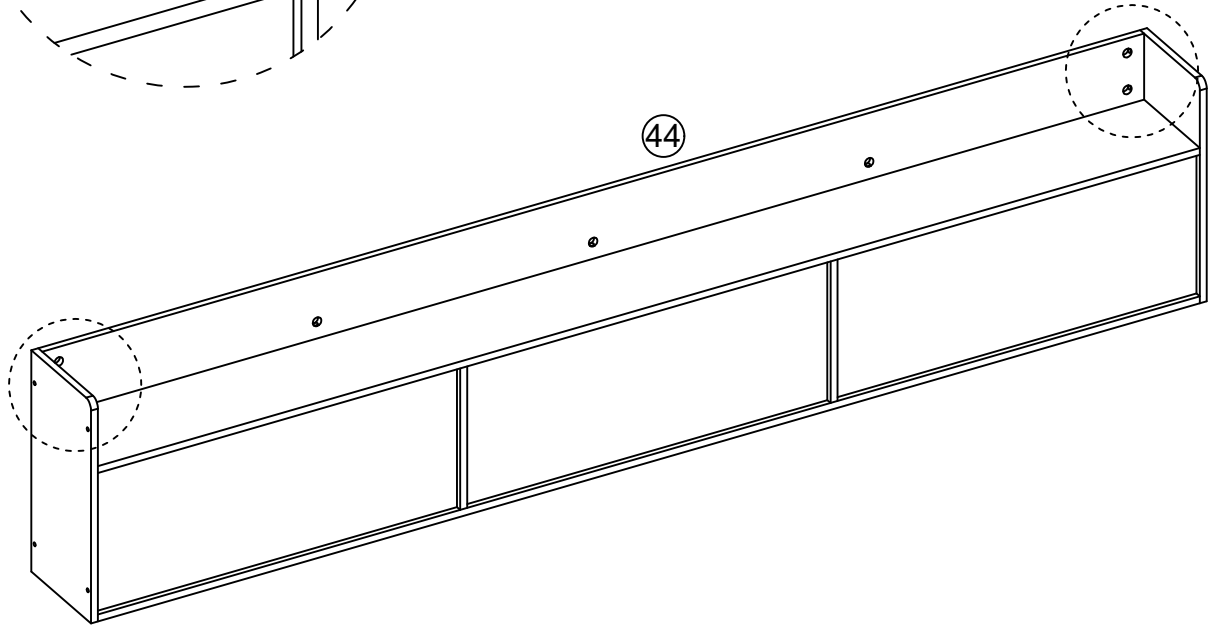

50

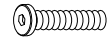

M6×40mm

M4

(M) × 4PCS

(X) × 1PC

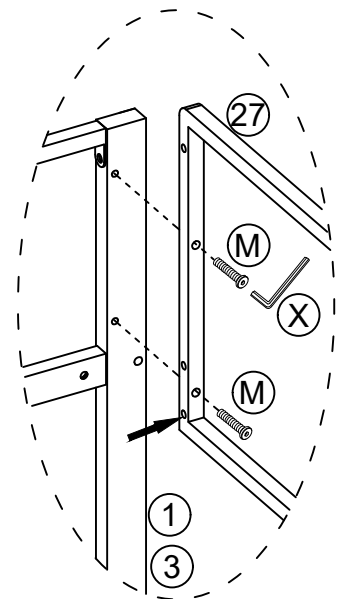
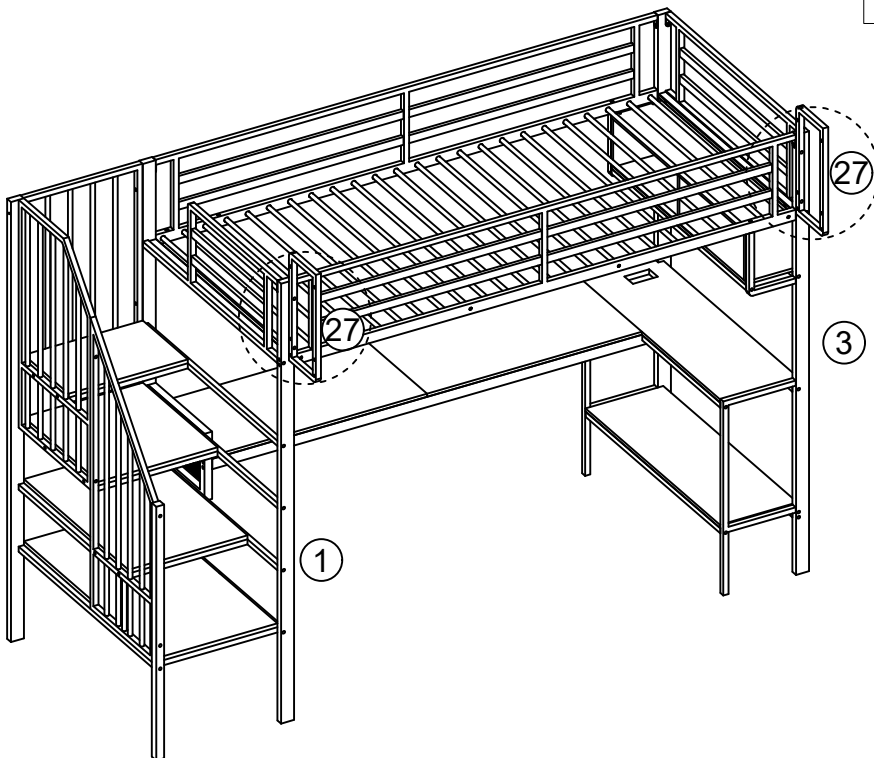

51

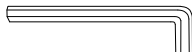
 M8×35mm	 M5
(F)×4PCS	(W)×1PC

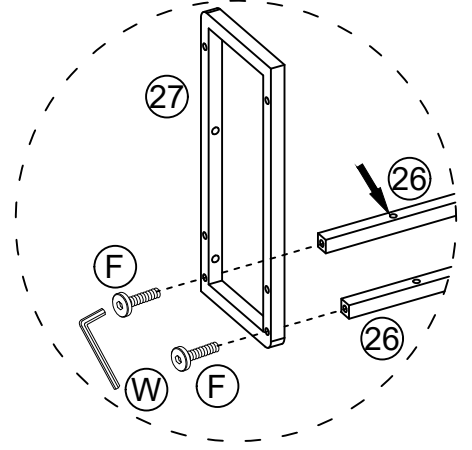
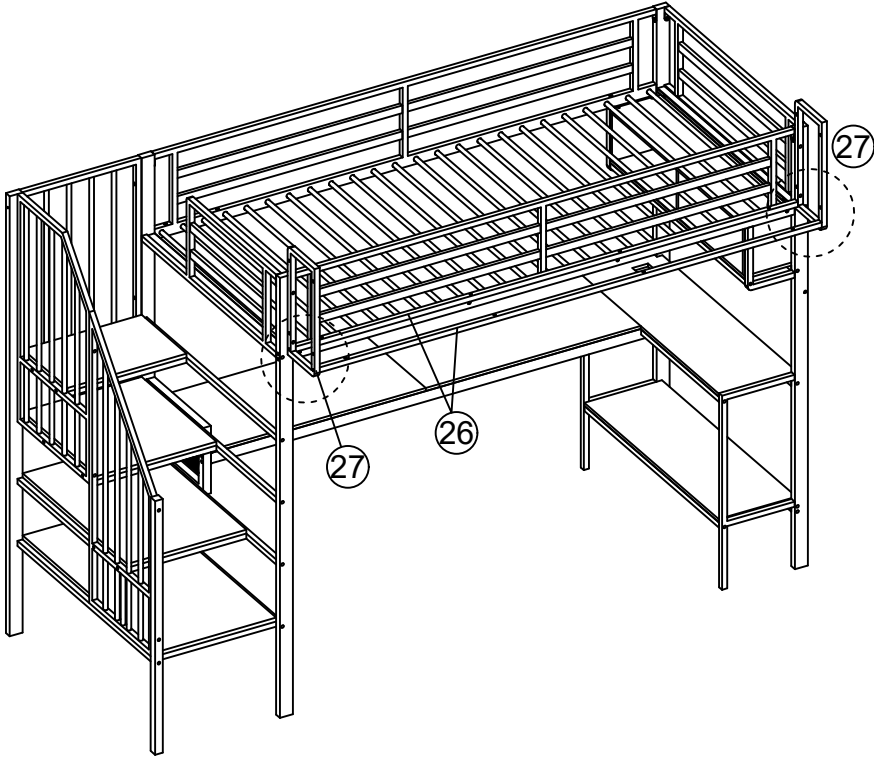

52

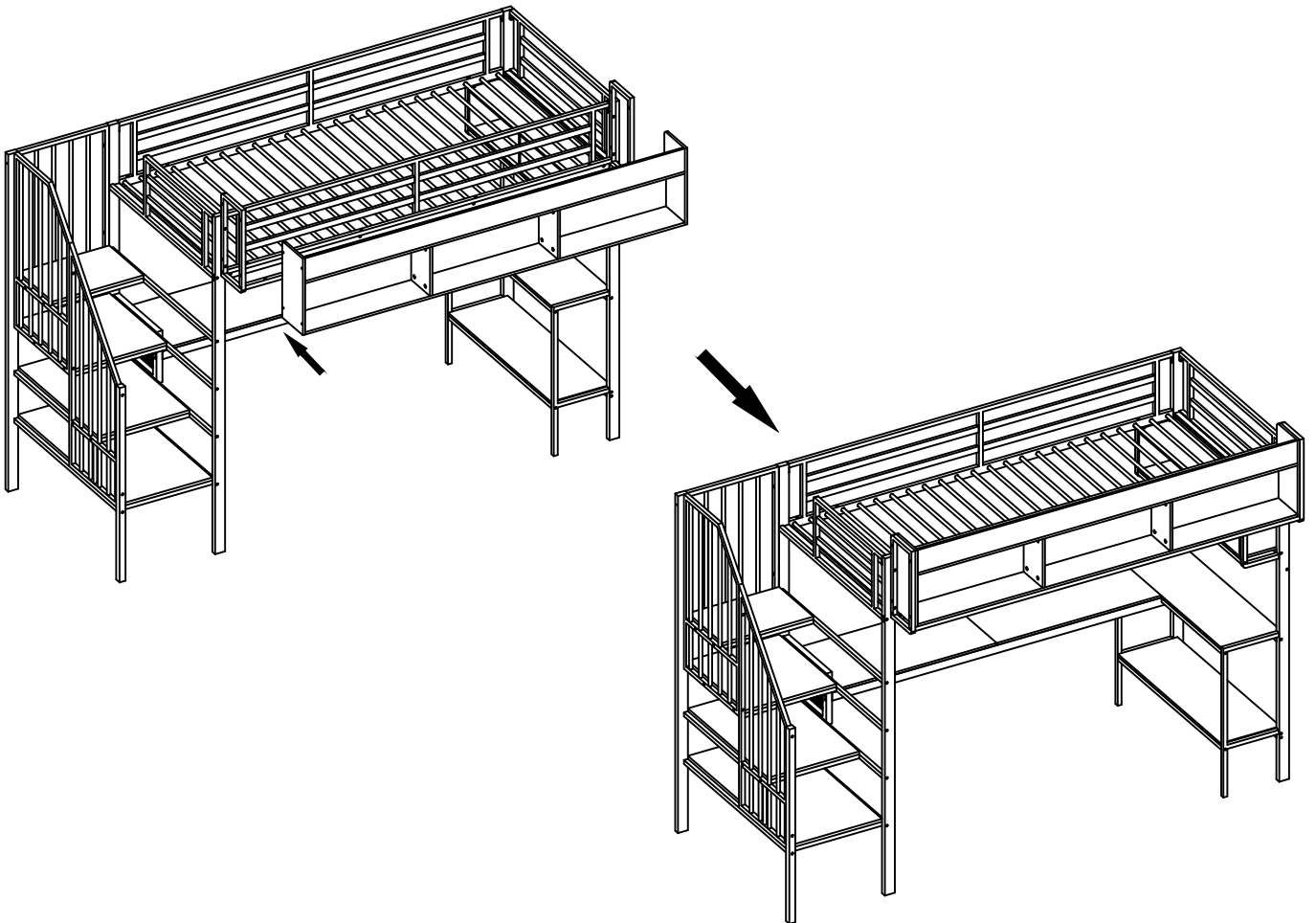

53

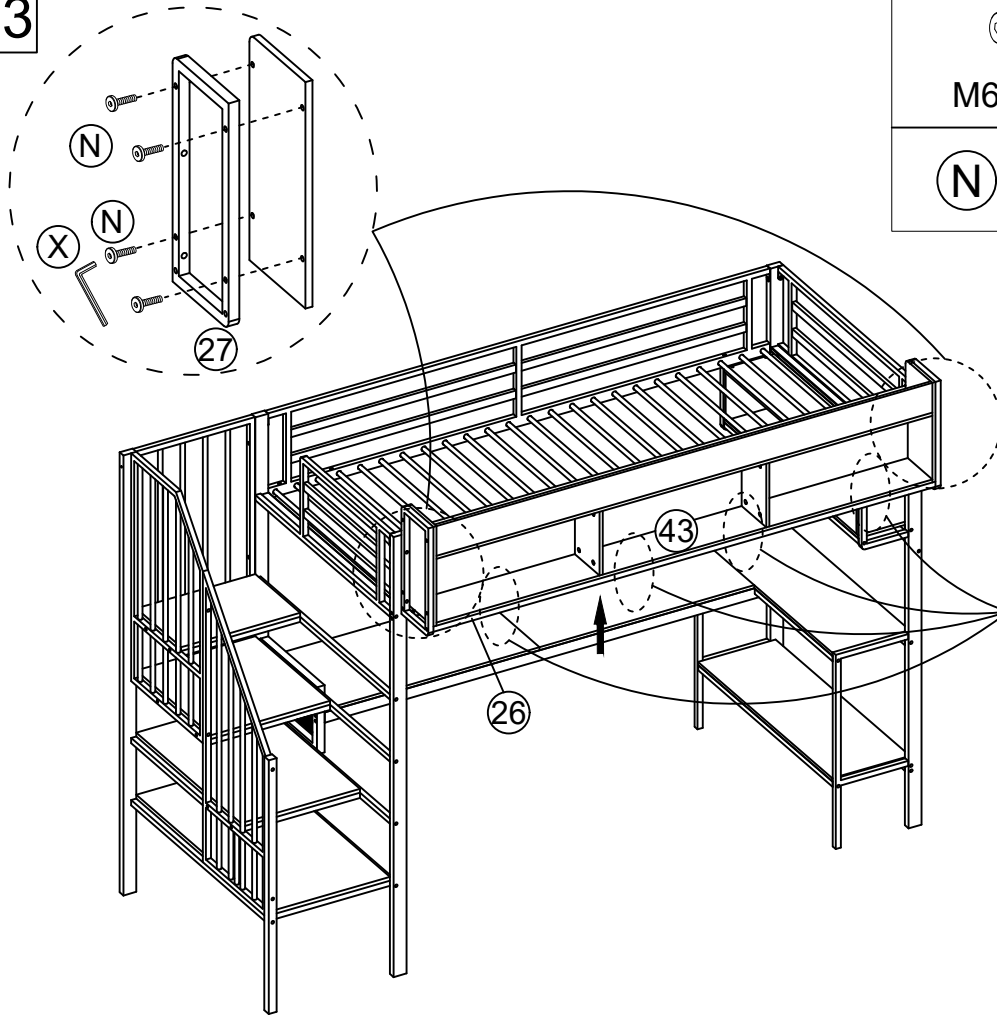

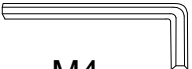

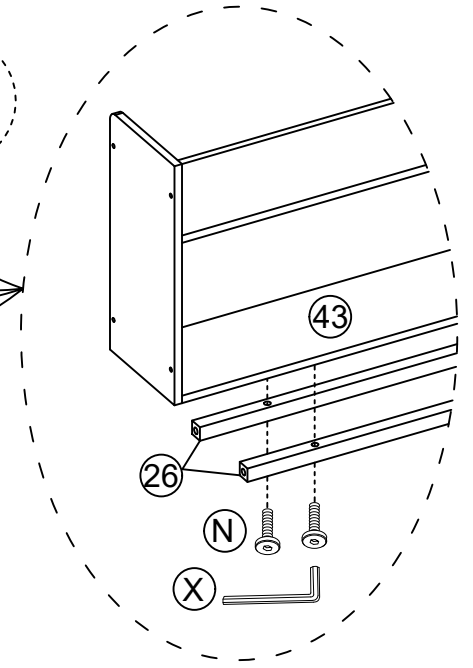
	
M6×30mm	M4
(N)×16PCS	(X)×1PC



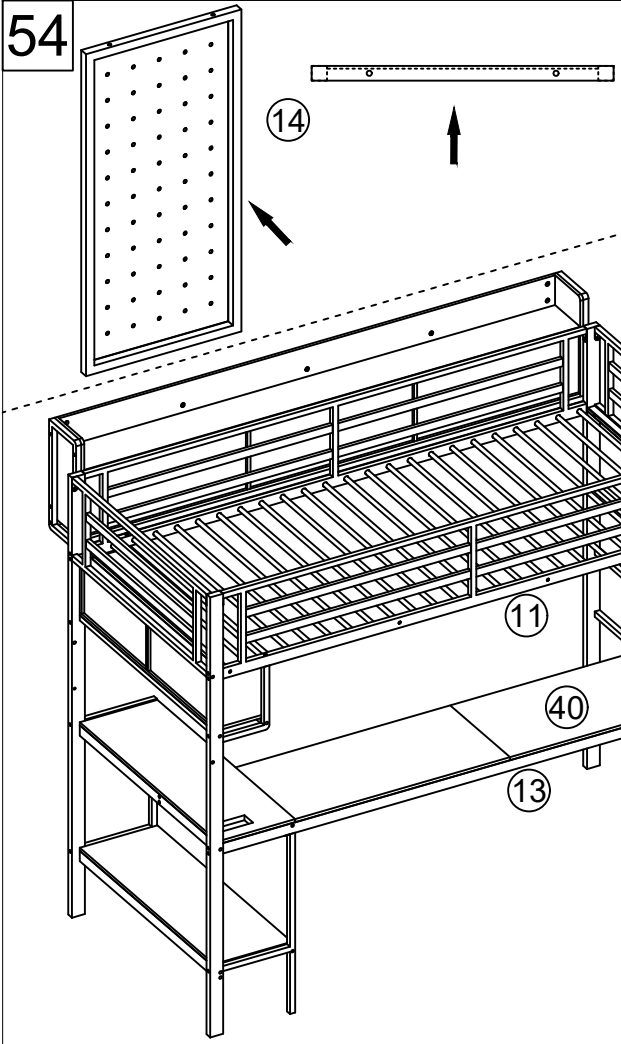

54

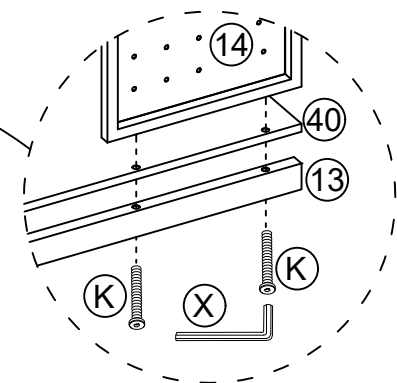
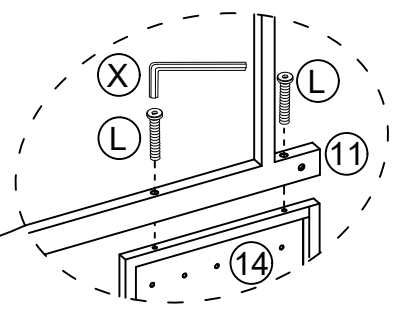

		
M6×65mm	M6×48mm	M4
(K)×2PCS	(L)×2PCS	(X)×1PC



55

 M3×12mm	
Ⓚ×2PCS	Ⓥ×1PC

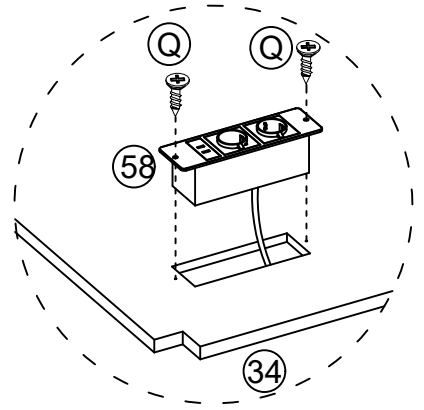
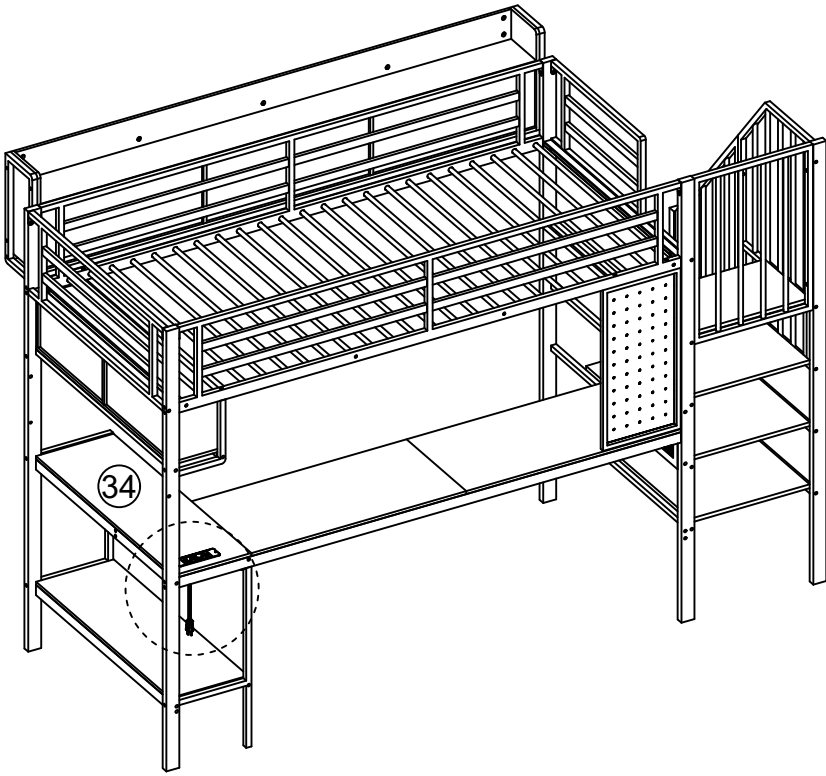

56

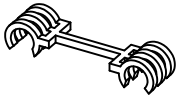
Ⓢ×23PCS

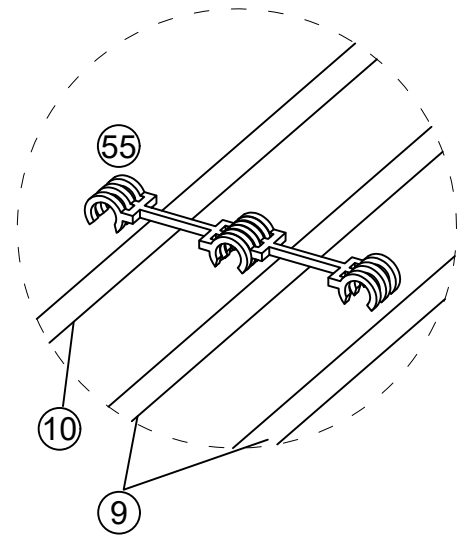
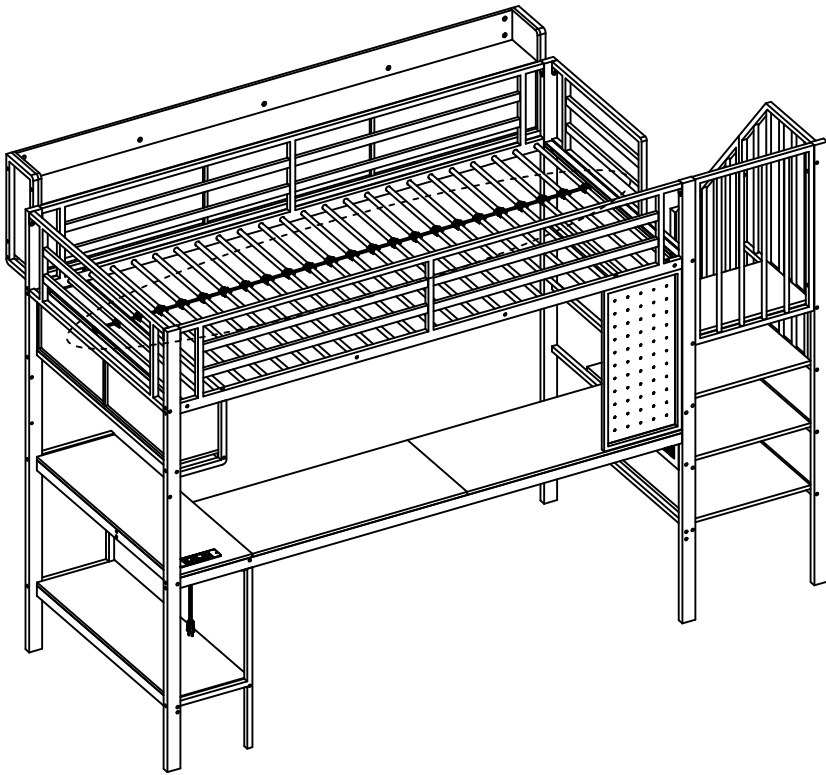



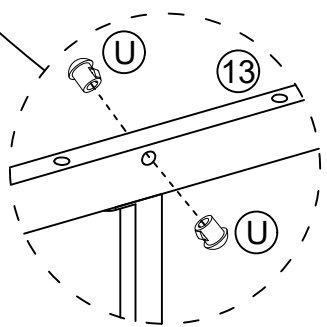
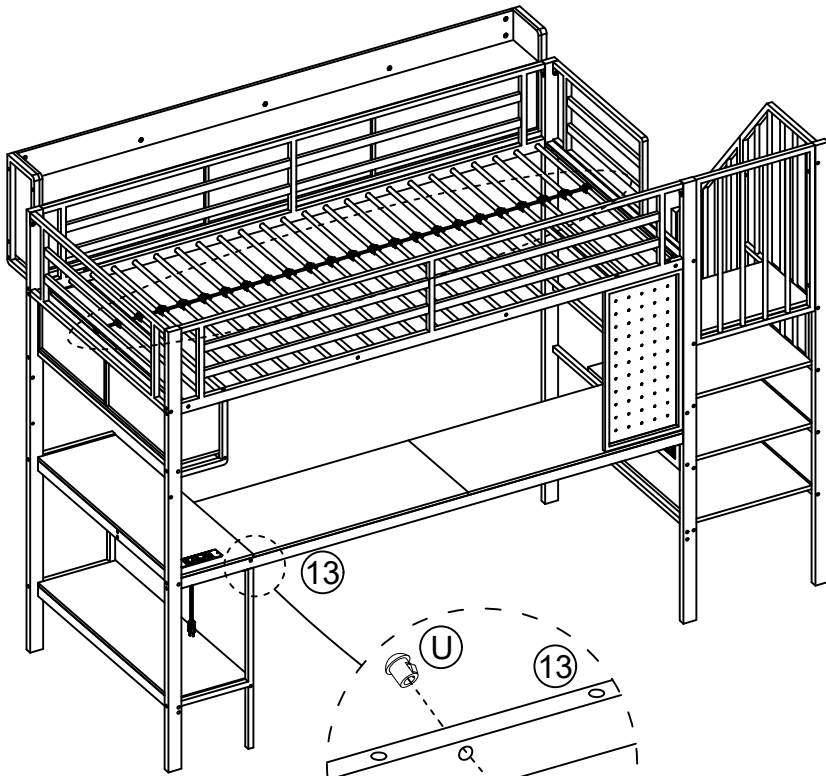
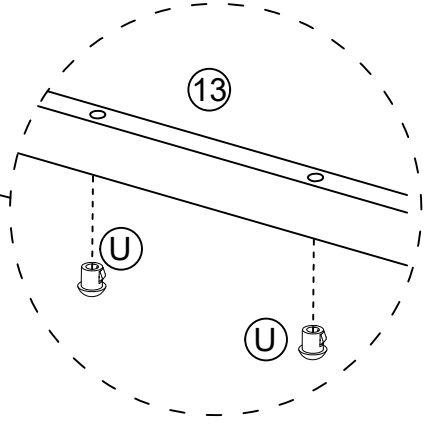
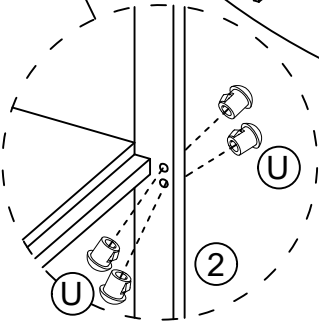
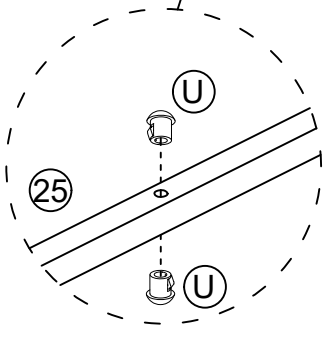
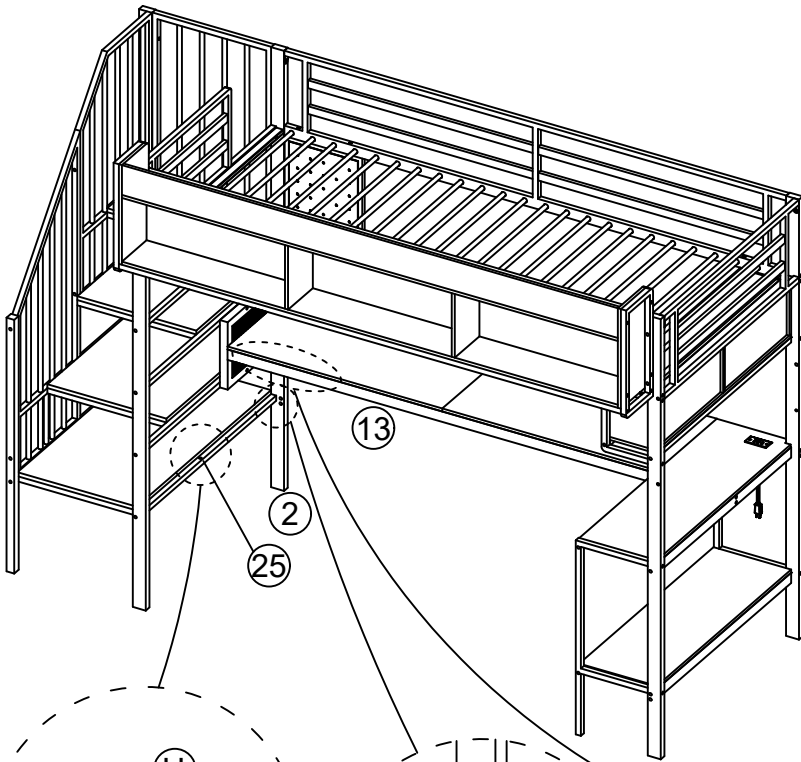

U × 10PCS





58

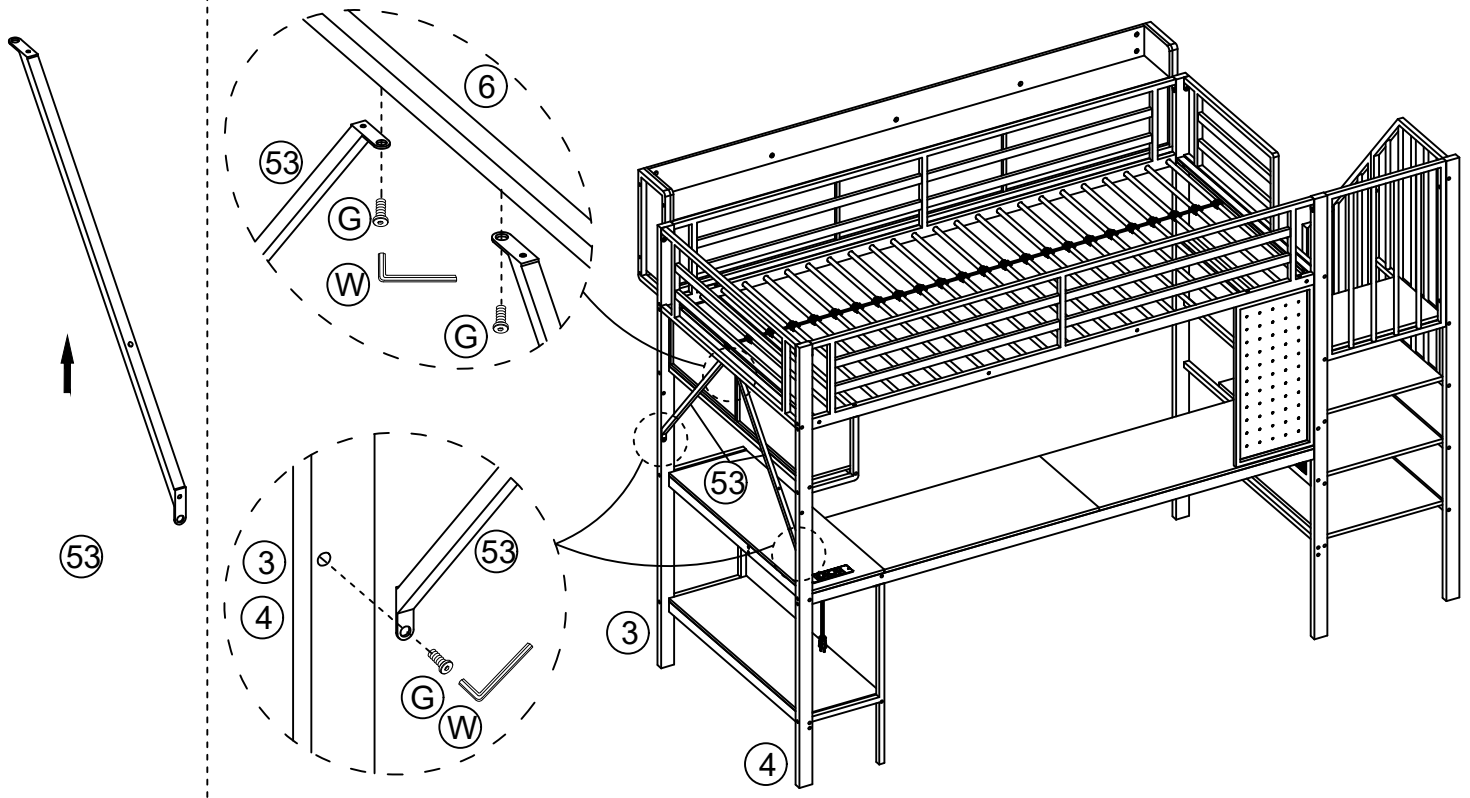





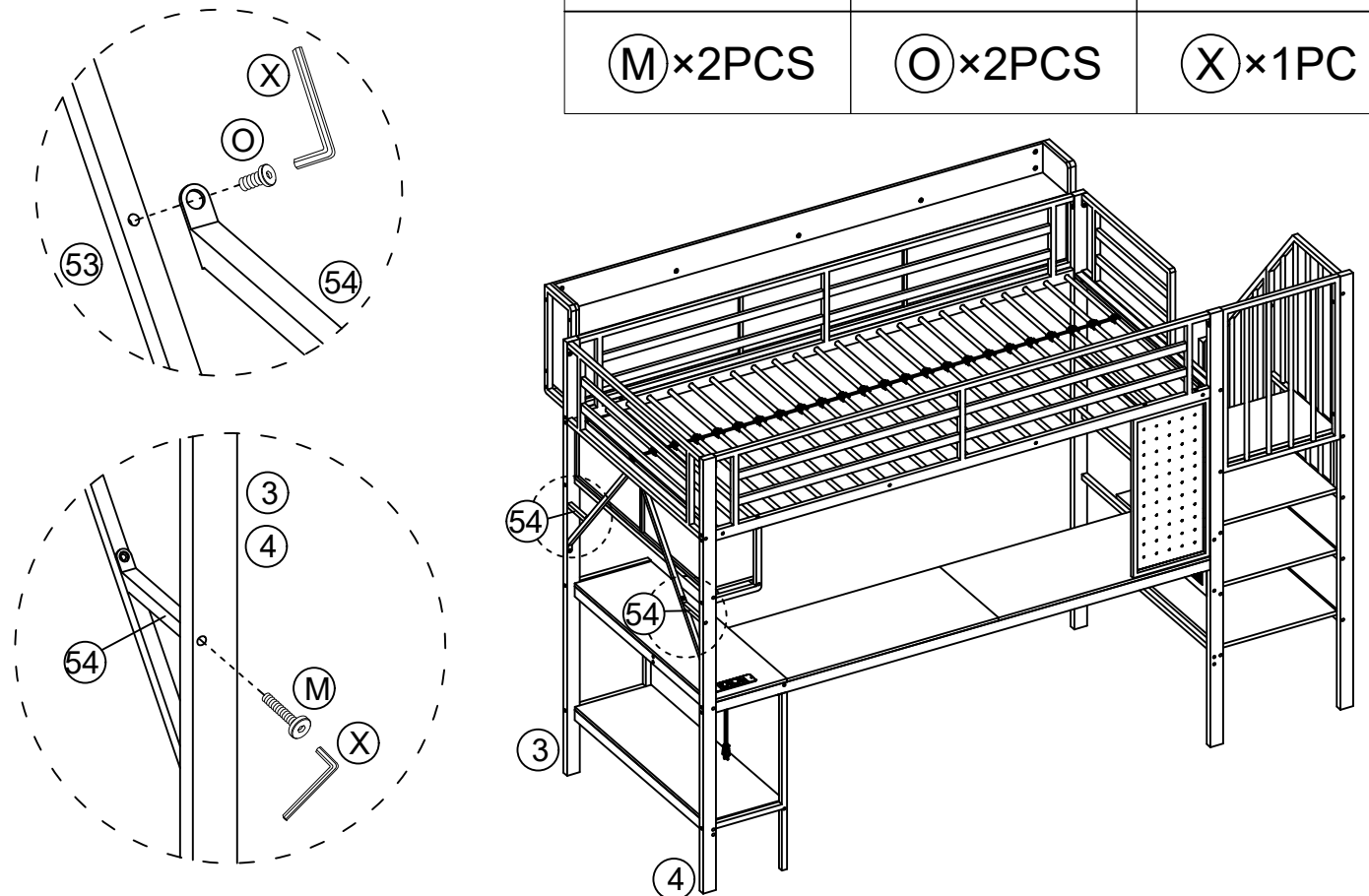

	
M8×20mm	M5
(G) ×4PCS	(W) ×1PC

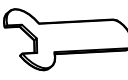
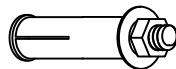
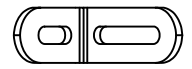

59

		
M6×40mm	M6*15mm	M4
(M) ×2PCS	(O) ×2PCS	(X) ×1PC



 M4	 M6×15mm			
(X)×1PC	(O)×2PCS	(J)×1PC	(I)×2PCS	(H)×2PCS
		 (15)	 (14)	 (13)
			 (12)	 (11)

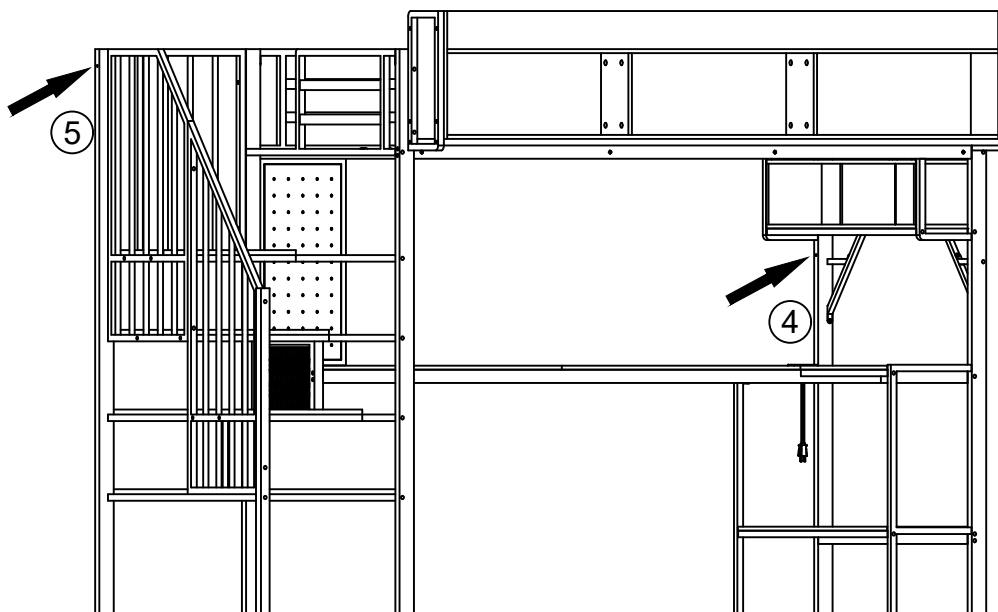
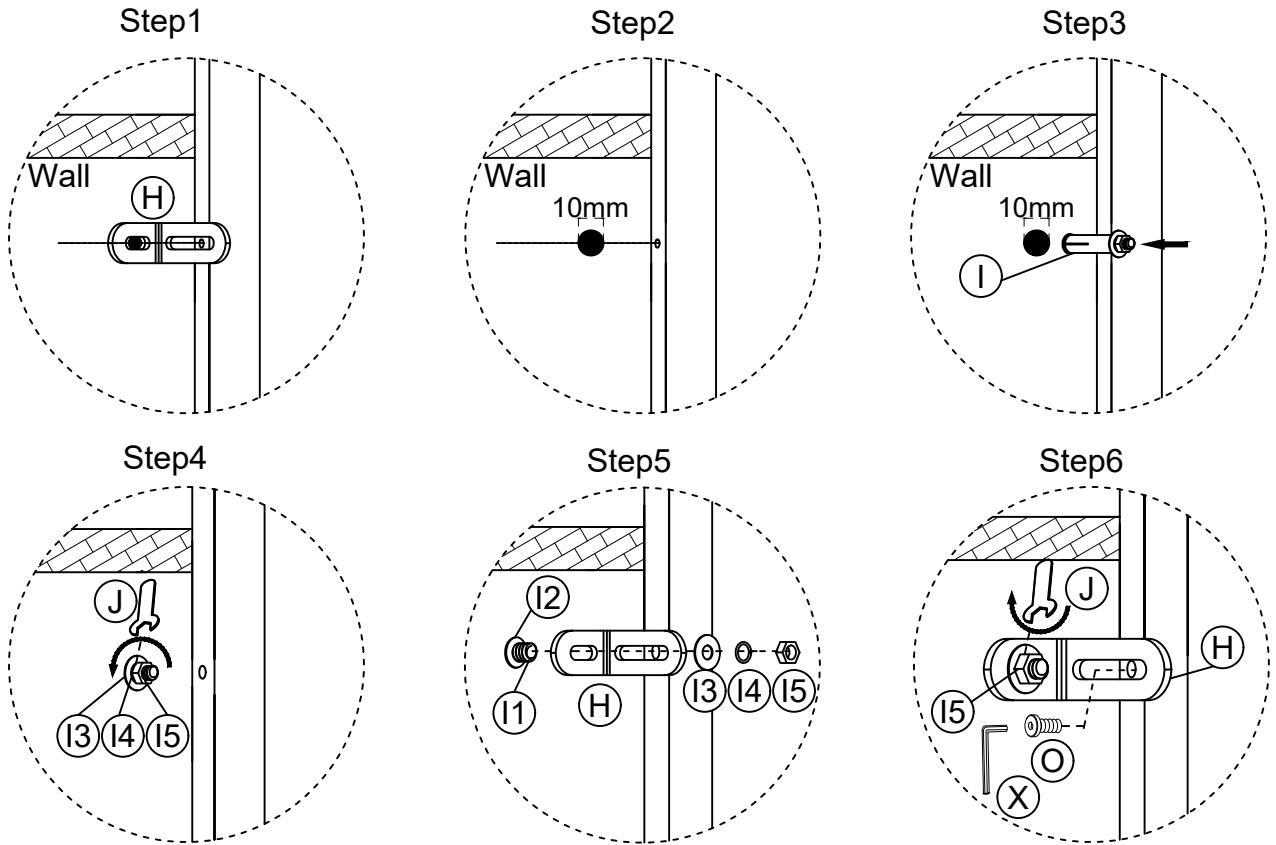

61

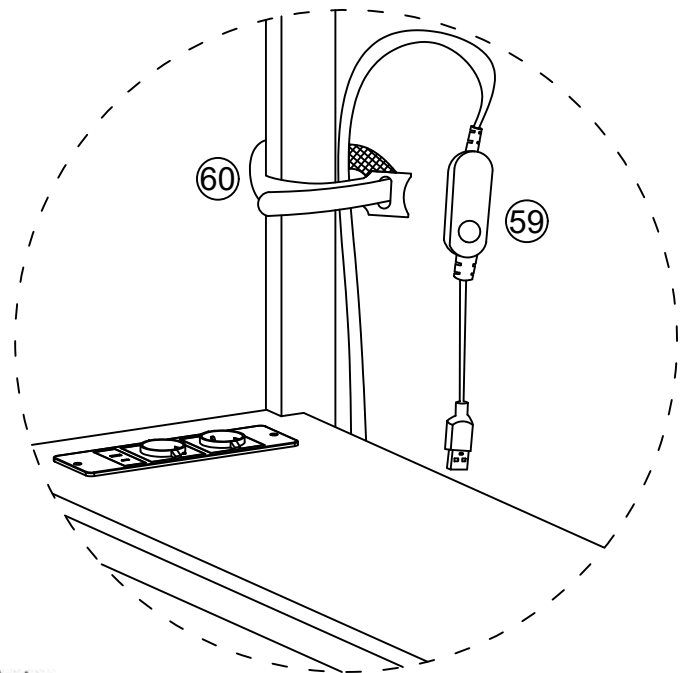
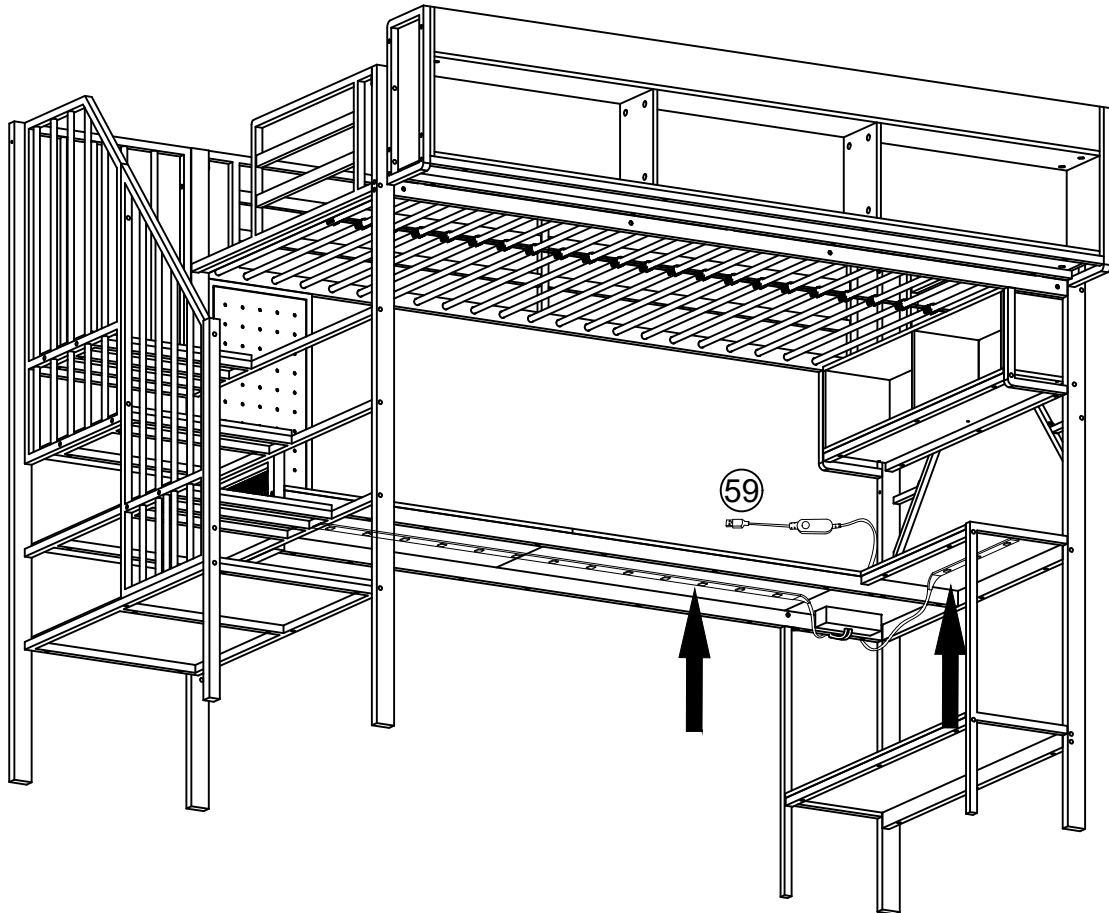
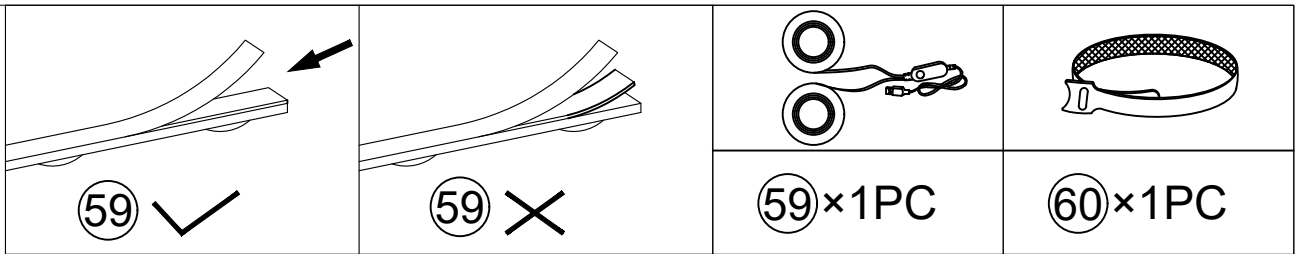

EN: Scan to download App control the Led light.

DE: Scannen, um die App zum Steuern des LED-Lichts herunterzuladen.

FR: Scanner pour télécharger App contrôler la lumière Led.

DE: Wenn Sie die Lichter nicht erfolgreich arbeiten lassen können, überprüfen Sie bitte die Folgendes:

1. Bitte überprüfen Sie die Fernbedienung. Sie müssen die Fernbedienung abreißen Plastikseptum vor Gebrauch.
2. Lassen Sie die Fernbedienung nicht zu weit vom Empfänger entfernt sein Es gibt kein Hindernis zwischen ihnen.
3. Bitte beachten Sie, dass die Fernbedienung für den Transport keine Batterien enthält. Das Batteriemodell lautet: **CR2025**

FR: Si vous ne parvenez pas à faire fonctionner les lumières correctement, veuillez vérifier les points suivants?:

1. Veuillez vérifier la télécommande. Vous devez retirer le septum en plastique de la télécommande avant utilisation.
2. Ne laissez pas la télécommande être trop éloignée du récepteur. Il n'y a aucun obstacle entre eux.
3. Veuillez noter que la télécommande ne contient pas de piles pour le transport. Le modèle de batterie est?: **CR2025**

UK: If you can't make the lights work successfully, please check the following:

1. Please check the remote control. You need to tear off the remote plastic septum before use.
2. Don't let the remote control be too far from the receiver There is no obstacle between them.
3. Please note that the remote control does not contain batteries for transportation. The battery model is: **CR2025**

1. Reverse remote control



2.



3. Unplug the battery



4. Hold the top dot with a ballpoint pen or round shape tool



5. Push two side and pull the Battery holder at same time



6.

Replace the battery



7.



8.



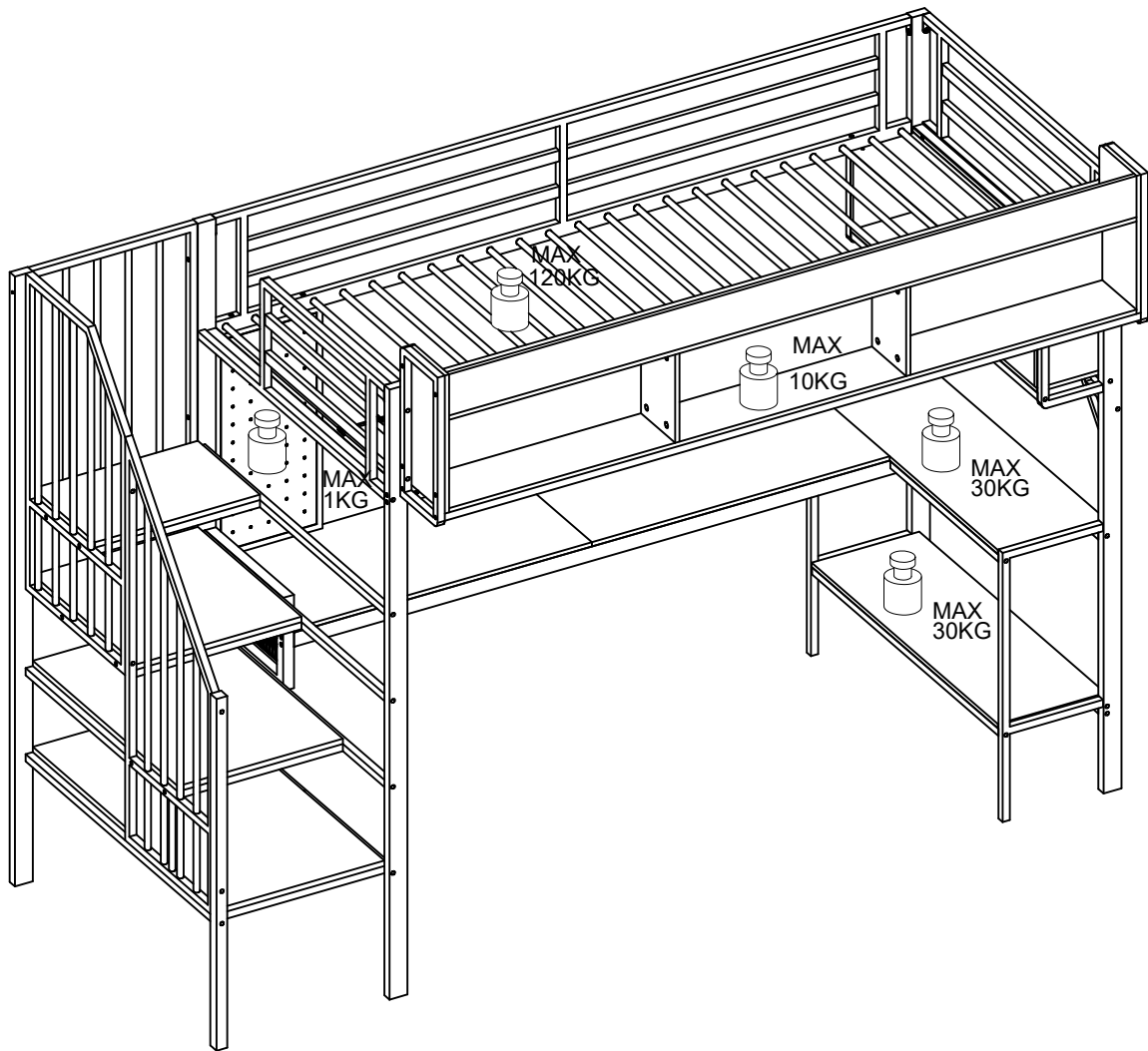

EU DECLARATION OF CONFORMITY

1. Product model/product (product, type, batch or serial number):

ZG-JJO-B2A-2A FURNITURE SOCKET 250V/16A/ 50Hz/60Hz

2. Name and address of the manufacturer or his authorised representative:

Guangdong Zhangong Electric Technology Co., LTD

701, Building 29, zhifuyuan Industrial Zone, Xingtan town, Shunde District, Foshan City, Guangdong Province

3. This declaration of conformity is issued under the sole responsibility of the manufacturer.

4. Object of the declaration (identification of electrical equipment allowing traceability, it may include a colour image of sufficient clarity where necessary for the identification of the electrical equipment): ZG-JJO-B2A-2A FURNITURE SOCKET 250V/16A/ 50Hz/60Hz

5. The object of the declaration described above is in conformity with the relevant Union harmonisation legislation: EMC Directive 2014/30/EU. Low Voltage Directive 2014/35/EU. RoHS Directive 2011/65/EU

6. References to the relevant harmonised standards used or references to the other technical specifications in relation to which conformity is declared: EN 55032:2015 + A11:2020 + A1:2020, EN 55035:2017 + A11:2020, EN IEC 61000-3-2:2019 + A1:2021 + A2:2024, EN 61000-3-3:2013 + A1:2019 + A2:2021

EN 61558-2-16:2009 + A1:2013 used in conjunction with EN IEC 61558-1:2019. IEC 62321-2:2021, IEC 62321-3-1:2013, IEC 62321-4:2013 + AMD1:2017, IEC 62321-5:2013, IEC 62321-7-2:2017 and IEC 62321-7-1:2015, IEC 62321-6:2015

7. Additional information: Risk of electric shock. Do not open. For indoor use only.

Signed for and on behalf of:

Guangdong Zhangong Electric Technology Co., LTD

(place and date of issue): 2025.12.2

Guangdong, NOV 30TH, 2025

(name, function) (signature): 钟晓云



Verification of Compliance

Verification No.: MK23020083-P01E01
Name and address of Applicant: **Shenzhen Hongzhengyu Technology Co., LTD**
 Shenzhen baoan district rock street industrial science and technology industrial park of 2 Haitian lanyu 3 5 floor of A
Name and address of Manufacturer: **Shenzhen Hongzhengyu Technology Co., LTD**
 Shenzhen baoan district rock street industrial science and technology industrial park of 2 Haitian lanyu 3 5 floor of A
Product name: **Lamp strip**
Rated: 5V --- 1A
Product model(s): HZY-2835-120D-12V, HZY-2835-30D-5V, HZY-2835-60D-5V, HZY-2835-120D-5V, HZY-2835-60D-12V, HZY-2835-60D-24V, HZY-2835-120D-24V, HZY-2835RGB-60D-5V, HZY-2835RGB-60D-12V, HZY-5050-30D-5V, HZY-5050-60D-5V, HZY-5050-30D-12V, HZY-5050-60D-12V, HZY-5050-60D-24V, HZY-5050RGB-30D-5V, HZY-5050RGB-60D-5V, HZY-5050RGB-30D-12V, HZY-5050RGB-60D-12V, HZY-5050RGB-60D-24V
Product trademark: N/A

This verification confirms that the product meets the requirements of the following standard.
 The conformity was demonstrated based on following standard(s) listed by European Commission as harmonized with EMC Directive 2014/30/EU.

EN IEC 55015:2019+A11:2020
 IEC 61547:2020

The verification has been carried out in accordance with individual rules and conditions agreed with the applicant. Evaluation has been carried out in accordance with:

Test report(s) No.: MK23020083-P01E01
Test conducted by: TMC Testing Services (Shenzhen) Co., Ltd.
Verification issue date: February 25, 2023

Notes:

This verification refers to the above mentioned product and its conformity in regards of above mentioned standard(s) was proven on test sample.

This verification does not imply meeting all essential requirements, assessment of the series-production or any other restricted Notified Bodies conformity assessment procedure appropriate for the product.

This verification holder shall use this verification in connection to verification of conformity and technical data relevant for the product the verification was issued.

TMC Testing Services (Shenzhen) Co., Ltd.

t:86-755-86642861 cert@tmc-lab.com www.tmc-lab.com

1st Floor, Block A1, Zone A, Xinshidai Gongrong Industrial Park, No. 2, Shihuan Road, Shiyuan Street, Baoan District, Shenzhen, China



Verification of Compliance

Verification No.:	MK23020083-P01C01
Name and address of Applicant:	Shenzhen Hongzhengyu Technology Co., LTD Shenzhen baoan district rock street industrial science and technology industrial park of 2 Haitian lanyu 3 5 floor of A
Name and address of Manufacturer:	Shenzhen Hongzhengyu Technology Co., LTD Shenzhen baoan district rock street industrial science and technology industrial park of 2 Haitian lanyu 3 5 floor of A
Product name:	Lamp strip HZY-2835-120D-12V, HZY-2835-30D-5V, HZY-2835-60D-5V, HZY-2835-120D-5V, HZY-2835-60D-12V, HZY-2835-60D-24V, HZY-2835-120D-24V, HZY-2835RGB-60D-5V, HZY-2835RGB-60D-12V, HZY-5050-30D-5V, HZY-5050-60D-5V, HZY-5050-30D-12V, HZY-5050-60D-12V, HZY-5050-60D-24V, HZY-5050RGB-30D-5V, HZY-5050RGB-60D-5V, HZY-5050RGB-30D-12V, HZY-5050RGB-60D-12V, HZY-5050RGB-60D-24V
Product model(s):	
Product trademark:	N/A

This verification confirms that the product meets the requirements of the following standard.

The conformity was demonstrated based on following standard(s) listed by European Commission as harmonized with Directive RoHS 2.0 Directive (EU) 2015/863 and (EU)2017/2102 amending Annex II to Directive 2011/65/EU

IEC 62321-1:2013	IEC 62321-3-1:2013
IEC 62321-4:2013/AMD1:2017	IEC 62321-5:2013
IEC 62321-6:2015	IEC 62321-7-1:2015
IEC 62321-7-2:2017	IEC 62321-8:2017

The verification has been carried out in accordance with individual rules and conditions agreed with the applicant. Evaluation has been carried out in accordance with:

Test report(s) No.:	MK23020083-P01C01
Test conducted by:	TMC Testing Services (Shenzhen) Co., Ltd.
Verification issue date:	February 25, 2023

Notes:

This verification refers to the above mentioned product and its conformity in regards of above mentioned standard(s) was proven on test sample.

This verification does not imply meeting all essential requirements, assessment of the series-production or any other restricted Notified Bodies conformity assessment procedure appropriate for the product.

This verification holder shall use this verification in connection to verification of conformity and technical data relevant for the product the verification was issued.

TMC Testing Services (Shenzhen) Co., Ltd.

t:86-755-86642861 cert@tmc-lab.com www.tmc-lab.com

1st Floor, Block A1, Zone A, Xinshidai Gongrong Industrial Park, No. 2, Shihuan Road, Shiyuan Street, Baoan District, Shenzhen, China





VERIFICATION OF CONFORMITY

No. : PTC25082917901E-RF01
Applicant : Dongguan Yihong Hardware electronics Co., LTD
Address : Room 1106,NO.2 Shangheng Road,Chang'an Town
Dongguan,Guangdong,523880 China
Manufacturer : Dongguan Yihong Hardware electronics Co., LTD
Address : Room 1106,NO.2 Shangheng Road,Chang'an Town
Dongguan,Guangdong,523880 China
Product : 2.4G Remote Controller
Trade Mark : -
Model : YH-629, YH-6181, YH-6183, YH-358
Ratings : DC 3V

The submitted sample of the above equipment has been tested and found to comply with the following European Directive:

Radio equipment Directive - 2014/53/EU

The standard(s) used for showing compliance with the essential requirements:

Applicable Standard(s)	Test Report(s) Number
ETSI EN 300 440 V2.2.1 (2018-07)	PTC25082917901E-EM01
ETSI EN 301 489-1 V2.2.3 (2019-11)	PTC25082917901E-EM02
ETSI EN 301 489-3 V2.3.2 (2023-01)	
EN 62479:2010	PTC25082917901E-EM03
EN IEC 62368-1:2020+A11:2020	PTC25082917901S-LD01



This verification is part of the full test report(s) and should be read in conjunction with it. This verification is based on an evaluation of one sample of above mentioned product. It does not imply assessment of the production of the product. Without the written approval of Precise Testing & Certification (Guangdong) Co., Ltd., this verification is not permitted to be reproduced, except in full. It is not permitted to use the test lab's logo. Provided that other applicable Directive requirements are satisfied, the manufacturer (or the European authorized representative), may draw up an EC/EEA Declaration of Conformity and affix the CE-marking to each conforming product.



Jacky Ou

Jacky Ou
Manager
Date: 2025-09-23



  	Importeur	DECOBUS HANDEL GMBH
	Address	Innungsstraße 9,21244 Buchholz,Deutschland
	Email/URL	https://www.decobusgroup.de
	Produktname	2.4G Remote Controller
	Hersteller	Dongguan Yihong Hardware electronics Co., LTD
	Address	Room 1106,NO.2 Shangheng Road,Chang'an Town Dongguan,Guangdong,523880 China
	Email/URL	522495222@qq.com
	Partienummer	C568ZLF20251027YO
	Nennspannung	DC3V
	Nennfrequenz	
Leistung		
Modell	YH-358	
Hergestellt in	China	
EC REP	DECOBUS HANDEL GMBH	
	Innungsstraße 9,21244 Buchholz,Deutschland	
	https://www.decobusgroup.de	



FR
**Cet appareil,
ses cordons,
et batterie
se recycle**

À DÉPOSER
EN MAGASIN

OU

À DÉPOSER
EN DÉCHÈTERIE

Points de collecte sur www.quefairedemesdechets.fr
Privilégiez la réparation ou le don de votre appareil !