

# SKU N635P420192+N635P420193+N635P420194

Importeur	Decobus Handel GmbH
Adresse	Innungsstraße 9, 21244 Buchholz, Deutschland
Email/URL	<a href="https://www.decobusgroup.de">https://www.decobusgroup.de</a>
Hersteller	Shenzhen Pinchengxin Technology co., Ltd
Adresse	3rd floor, 8 building Yuanling industrialzon, No. 39 Yuanlingcun road, Shiyao
Email/URL	fosm11@foxmail.com
Partienummer	101147
Hergestellt in	China
	Decobus Handel GmbH Innungsstraße 9, 21244 Buchholz, Deutschland <a href="https://www.decobusgroup.de">https://www.decobusgroup.de</a>
	Produkt: 5050 RGB LED Strip Lights Modell: 5050RGB 60D/M 5V Nennspannung: 5V Nennfrequenz: 60HZ Leistung: 28W

Importeur	Decobus Handel GmbH
Adresse	Innungsstraße 9, 21244 Buchholz, Deutschland
Email/URL	<a href="https://www.decobusgroup.de">https://www.decobusgroup.de</a>
Hersteller	GUANG TAI ENTERPRISE CO.,LTD
Adresse	Rm 402, Bldg 4, No.2 Dapianmei Rd., Dapianmei Village, Dalingshan, DONGGUAN, Guangdong, China
Email/URL	22495239@qq.com
Partienummer	101147
Hergestellt in	China
	Decobus Handel GmbH Innungsstraße 9, 21244 Buchholz, Deutschland <a href="https://www.decobusgroup.de">https://www.decobusgroup.de</a>
	Produkt: Furniture Power Distribution Unit Modell: JN02-00-22 Nennspannung: 125-250V Nennfrequenz: 50/60HZ Leistung: 1500W

Importeur	Decobus Handel GmbH
Adresse	Innungsstraße 9,21244 Buchholz,Deutschland
URL	<a href="https://www.decobusgroup.de">https://www.decobusgroup.de</a>
Hersteller	ZHANGZHOU XINZUOBIAO INDUSTRY & TRADE CO.,LTD.
Adresse	BeidouIndustrial Zone,ZhangzhouCity, Fujian Province, China
Email/URL	2092167066@qq.com
Partienummer	101147
Hergestellt in	China
	Decobus Handel GmbH Innungsstraße 9,21244 Buchholz,Deutschland <a href="https://www.decobusgroup.de">https://www.decobusgroup.de</a>

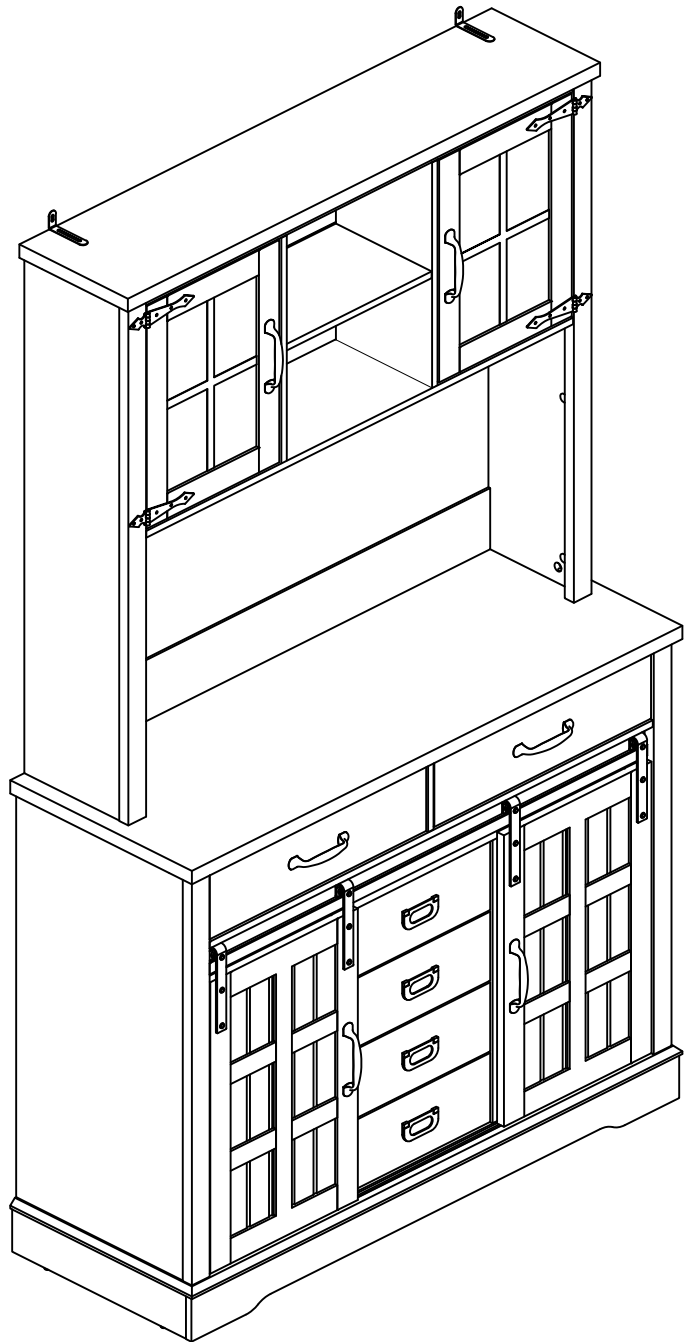

**FR**  
 Pensez à donner ou recycler. Association Magasin Déchèterie  
<https://quefairedemesdechets.fr>

**FR**  
 Cet appareil, ses cordons, et batterie se recyclent A DÉPOSER EN MAGASIN A DÉPOSER EN DÉCHÈTERIE  
 Points de collecte sur [www.quefairedemesdechets.fr](http://www.quefairedemesdechets.fr)  
 Privilégiez la réparation ou le don de votre appareil !

**FR**

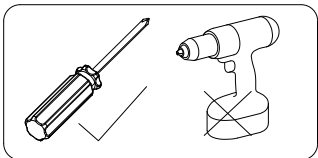
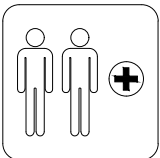
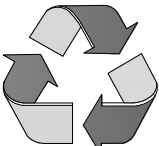

**EN\_IMPORTANT,RETAIN FOR FUTURE REFERENCE;READ CAREFULLY.  
 FR\_IMPORTANT:A LIRE ATTENTIVEMENT ET ACONSERVER POUR CONSULTATION ULTERIEURE.  
 ES\_IMPORTANTE,LEA Y GARDE PARA FUTURAS REFEREBCUAS.  
 DE\_„WICHTIG!SORGEALTIG LESEN UND FUR SPATER NACHSCHLAGEN AUFBEWAHREN."  
 IT\_IMPORTANTE! CONSERVARE IL PRESENTE MANUALE PER FUTURO RIFERIMENTO E LEGGERLO ATTENTAMENTE.**

**EN**

Dear customer,  
Thank you for purchasing this product. So that your appliance serves you well, please read all the instructions in this user's manual. If you have any questions, please contact our customer care center.

**FR**

Cher client,  
Nous vous remercions d'avoir acheté ce produit. Afin que vous puissiez profiter pleinement de votre appareil, veuillez lire toutes les instructions de ce manuel d'utilisation. Si vous avez la moindre question, veuillez contacter notre centre d'assistance à la clientèle.

**DE**

Sehr geehrter Kunde,  
Vielen Dank, dass Sie dieses Produkt erworben haben. Damit Ihr Gerät Ihnen gute Dienste leistet, lesen Sie bitte alle Hinweise in diesem Benutzerhandbuch. Wenn Sie Fragen haben, wenden Sie sich bitte an unser Kundendienstzentrum.

**ES**

Queridos clientes,  
Gracias por comprar este producto. Para que su electrodoméstico le sirva mejor, lea todas las instrucciones de este manual del usuario. Si tiene alguna pregunta, comuníquese con nuestro Centro de Atención al Cliente.

**IT**

Caro Cliente,  
Grazie per aver acquistato questo prodotto. Per servirti meglio con questo apparecchio ti prego di leggere tutte le istruzioni in presente manuale utente. In caso di dubbio, si prega di contattare il nostro centro assistenza clienti.

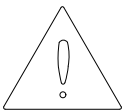

Our product will be delivered to you in 3 packages. The delivery times of these 3 packages may differ, please be patient and thank you for your understanding.

Unser Produkt wird Ihnen in 3 Paketen geliefert. Die Lieferzeiten dieser 3 Pakete können abweichen, bitte haben Sie etwas Geduld und vielen Dank für Ihr Verständnis.

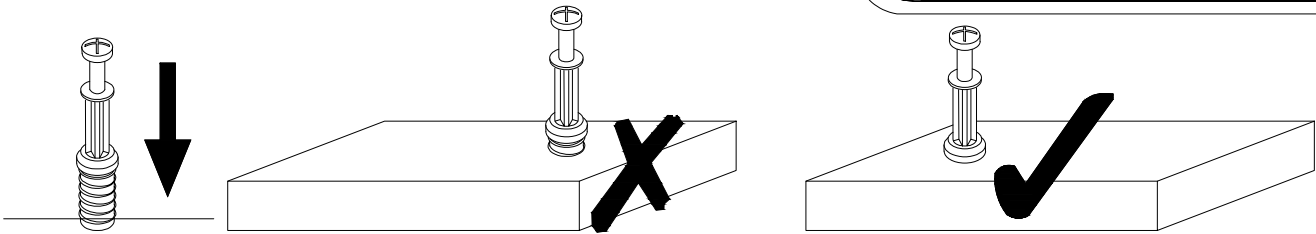

EN\_QUICKFIT: Tighten quickfit until shoulder is flush with panel. Do not overtighten or undertighten.

FR\_RACCORD RAPIDE: Faites serrer le raccord rapide jusqu'a ce que l'épaulement soit parfaitement encstre dans le panneau. Il ne faut ni trop serrer ni insuffisamment serrer.

ES\_QUICKFIT: Apriete quickfit hasta que el hombro se descargue con el panel. NO lo sobreapriete ni lo apriete poco.

DE\_QUICKFIT: Ziehen Sie den quickfit fest, bis die Schulter mit der Platte bundig ist. Bitte nicht zu fest oder zu schwach anziehen.

IT\_MONTAGGIO RAPIDO: Stringere il montaggio rapido fino aquando la spalla e a filo con il pannello, non stringere troppo o troppo poco.

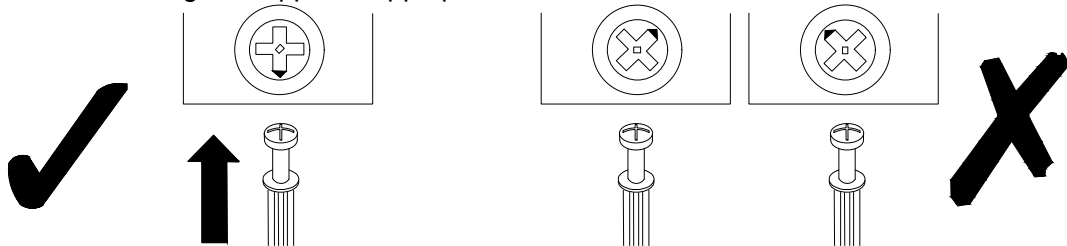

EN\_CAM LOCK: When fitting cam lock, ensure starting position is correct before you insert connecting quickfit.

FR\_SERRURE BATTEUSE: Avant d'insérer la serrure batteuse, veillez a la bonne orientation avant d'insérer le raccord rapide,

ES\_CIERRE DE LA CAMARA: Cuando instale el cierre de la camara, asegurese de que la posicion de inicio es correcta antes de que inserte el quickfit conector,

De\_CAM-LOCK: Achten Sie bei der Montage des Cam-locks auf die richtige Ausgangsposition, bevor Sie den Quickfit einsetzen.

IT\_BLOCCAGGIO A CAMMA: Quando si monta il bloccaggio a camma, assicurarsi che la posizione iniziale sia corretta prima di inserire il montaggio rapido di collegamento.

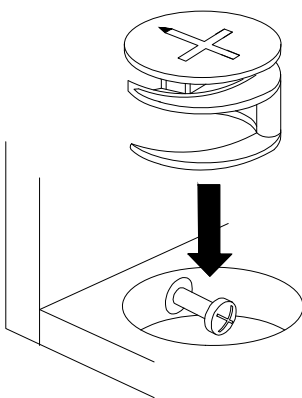

EN\_Quickfit head should be in the centre of the cam lock when the two panels are joined.

Cam lock should be inserted before quickfit.

FR\_Lorsque les deux panneaux sont assembles, la tete du raccord rapide doit reposer au centre de la serrure batteuse. Il faut inserer la serrure batteuse avant le raccord rapide.

ES\_EL cabezal del quickfit debe estar en el centro del cierre de la camara cuando se unan los dos paneles.

Se debe insertar el cierre de la camara antes que el quickfit.

DE\_Der Quickfit-Kopf sollte sich in der Mitte des Cam-locks befinden, wenn die beiden Platten zusammengefügt sind.

Der Cam-lock sollte vor dem Quickfit eingesetzt werden.

IT\_La testa del montaggio rapido deve trova rsi al centro del bloccaggio a camma quando i due pannelli sono uniti.

Il Bloccaggio a Camma deve essere inserito prima del montaggio rapido.

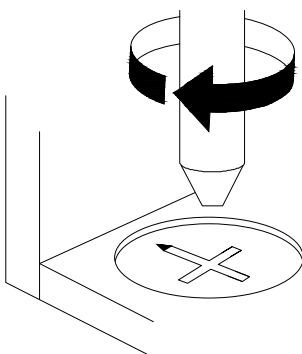

EN\_Turn cam lock clockwise to tighten.

FR\_Faites tourner la serrure batteuse dans le sens des aiguilles d'une montre pour la resserrer.

ES\_Gire el cierre de la camara en sentido horario para apretarlo.

DE\_Drehen Sie den Cam-Lock im Uhrzeigersinn, um ihn festzuziehen.

IT\_Rutotare il bloccaggio a camma in senso oragio per stringere.

**DE**

1. Die maximale Tragfähigkeit der Oberplatte beträgt 60 kg, bitte nicht überladen.
2. Lassen Sie Kinder nicht auf Möbeln klettern, da dies zu Umstürzen und schweren Verletzungen führen kann.
3. Um die Sicherheit zu gewährleisten, installieren Sie bitte gemäß der Anleitung und ziehen Sie bei Bedarf Fachleute hinzu.
4. Stellen Sie Möbel nicht in die Nähe von Feuerquellen oder heißen Gegenständen, um Brandgefahr zu vermeiden.
5. Stellen Sie Möbel nicht in feuchten Umgebungen auf, um Materialschäden zu verhindern.
6. Überprüfen Sie regelmäßig alle Verbindungs- und Befestigungselemente, um sicherzustellen, dass sie fest sitzen und Unfälle zu vermeiden.
7. Dieses Produkt ist mit einem Kipp-Schutz ausgestattet, installieren Sie diesen Schutz, um Verletzungen durch Umstürzen zu vermeiden.

**UK**

1. The maximum weight capacity of the top panel is 60kg; please do not overload.
2. Do not allow children to climb on furniture, as this may cause tipping and serious injury.
3. To ensure safety, please install correctly according to the instructions and seek professional assistance if necessary.
4. Do not place furniture near fire sources or hot objects to avoid fire hazards.
5. Do not place furniture in damp environments to prevent material damage.
6. Regularly check all connectors and fasteners to ensure they are secure to prevent accidents.
7. This product comes with an anti-tipping device; install this device to prevent injuries from tipping.

**IT**

1. La capacità massima del pannello superiore è di 60 kg; non sovraccaricare.
2. Non permettere ai bambini di arrampicarsi sui mobili, poiché ciò può causare ribaltamenti e gravi infortuni.
3. Per garantire la sicurezza, installare correttamente secondo le istruzioni e, se necessario, chiedere assistenza a professionisti.
4. Non posizionare i mobili vicino a fonti di calore o oggetti caldi per evitare rischi di incendio.
5. Non posizionare i mobili in ambienti umidi per prevenire danni ai materiali.
6. Controllare regolarmente tutti i connettori e le viti per assicurarsi che siano saldi e prevenire incidenti.
7. Questo prodotto è dotato di un dispositivo anti-ribaltamento; installare questo dispositivo per evitare infortuni da ribaltamento.

**ES**

1. La capacidad máxima del panel superior es de 60 kg; no sobrecargar.
2. No permita que los niños escalen los muebles, ya que esto puede causar volcaduras y lesiones graves.
3. Para garantizar la seguridad, instale correctamente según las instrucciones y busque ayuda profesional si es necesario.
4. No coloque los muebles cerca de fuentes de fuego u objetos calientes para evitar riesgos de incendio.
5. No coloque los muebles en ambientes húmedos para evitar daños en los materiales.
6. Revise regularmente todos los conectores y sujetadores para asegurarse de que estén seguros y prevenir accidentes.
7. Este producto viene con un dispositivo anti-vuelco; instale este dispositivo para prevenir lesiones por vuelcos.

**NL**

1. De maximale draagcapaciteit van het bovenpaneel is 60 kg; niet overbelasten.
2. Laat kinderen niet op meubels klimmen, dit kan leiden tot omvallen en ernstige verwondingen.
3. Installeer correct volgens de instructies om de veiligheid te waarborgen, en schakel indien nodig professionele hulp in.
4. Plaats meubels niet in de buurt van vuurbronnen of warme objecten om brandgevaar te voorkomen.
5. Plaats meubels niet in vochtige omgevingen om materiaalschade te voorkomen.
6. Controleer regelmatig alle verbindingen en bevestigingsmiddelen om ervoor te zorgen dat ze stevig zijn en om ongevallen te voorkomen.
7. Dit product is uitgerust met een kantelbeveiliging; installeer dit apparaat om verwondingen door omvallen te voorkomen.

**SE**

1. Den maximala viktkapaciteten för överpanelen är 60 kg; överbelasta inte.
2. Låt inte barn klättra på möbler, då detta kan orsaka tippning och allvarliga skador.
3. För att säkerställa säkerheten, installera korrekt enligt instruktionerna och sök professionell hjälp om det behövs.
4. Placera inte möbler nära eldkällor eller heta föremål för att undvika brandrisk.
5. Placera inte möbler i fuktiga miljöer för att förhindra skador på materialen.
6. Kontrollera regelbundet alla kopplingar och fästelement för att säkerställa att de är säkra för att förhindra olyckor.
7. Denna produkt levereras med en anti-tippanordning; installera denna anordning för att förhindra skador vid tippning.

**PL**

1. Maksymalne obciążenie górnej płyty wynosi 60 kg; nie przeciążaj.
2. Nie pozwól dzieciom wspinać się na meble, ponieważ może to prowadzić do przewrócenia się i poważnych obrażeń.
3. Aby zapewnić bezpieczeństwo, zainstaluj prawidłowo zgodnie z instrukcją i w razie potrzeby skorzystaj z pomocy profesjonalistów.
4. Nie stawiaj mebli w pobliżu źródeł ognia lub gorących przedmiotów, aby uniknąć ryzyka pożaru.
5. Nie stawiaj mebli w wilgotnych środowiskach, aby zapobiec uszkodzeniu materiałów.
6. Regularnie sprawdzaj wszystkie złącza i elementy mocujące, aby upewnić się, że są stabilne i aby zapobiec wypadkom.
7. Produkt ten jest wyposażony w urządzenie zapobiegające przewróceniu; zainstaluj to urządzenie, aby uniknąć obrażeń w wyniku przewrócenia.

**FR**

1. La charge maximale du panneau supérieur est de 60 kg, ne pas surcharge.
2. Ne laissez pas les enfants grimper sur les meubles, cela peut entraîner des basculements et des blessures graves.
3. Pour garantir la sécurité, installez correctement selon les instructions et demandez l'aide de professionnels si nécessaire.
4. Ne placez pas les meubles près de sources de chaleur ou d'objets chauds pour éviter les risques d'incendie.
5. Ne placez pas les meubles dans des environnements humides pour éviter d'endommager les matériaux.
6. Vérifiez régulièrement tous les connecteurs et les fixations pour vous assurer qu'ils sont bien serrés et éviter les accidents.
7. Ce produit est équipé d'un dispositif anti-basculement; installez ce dispositif pour éviter les blessures dues au basculement.

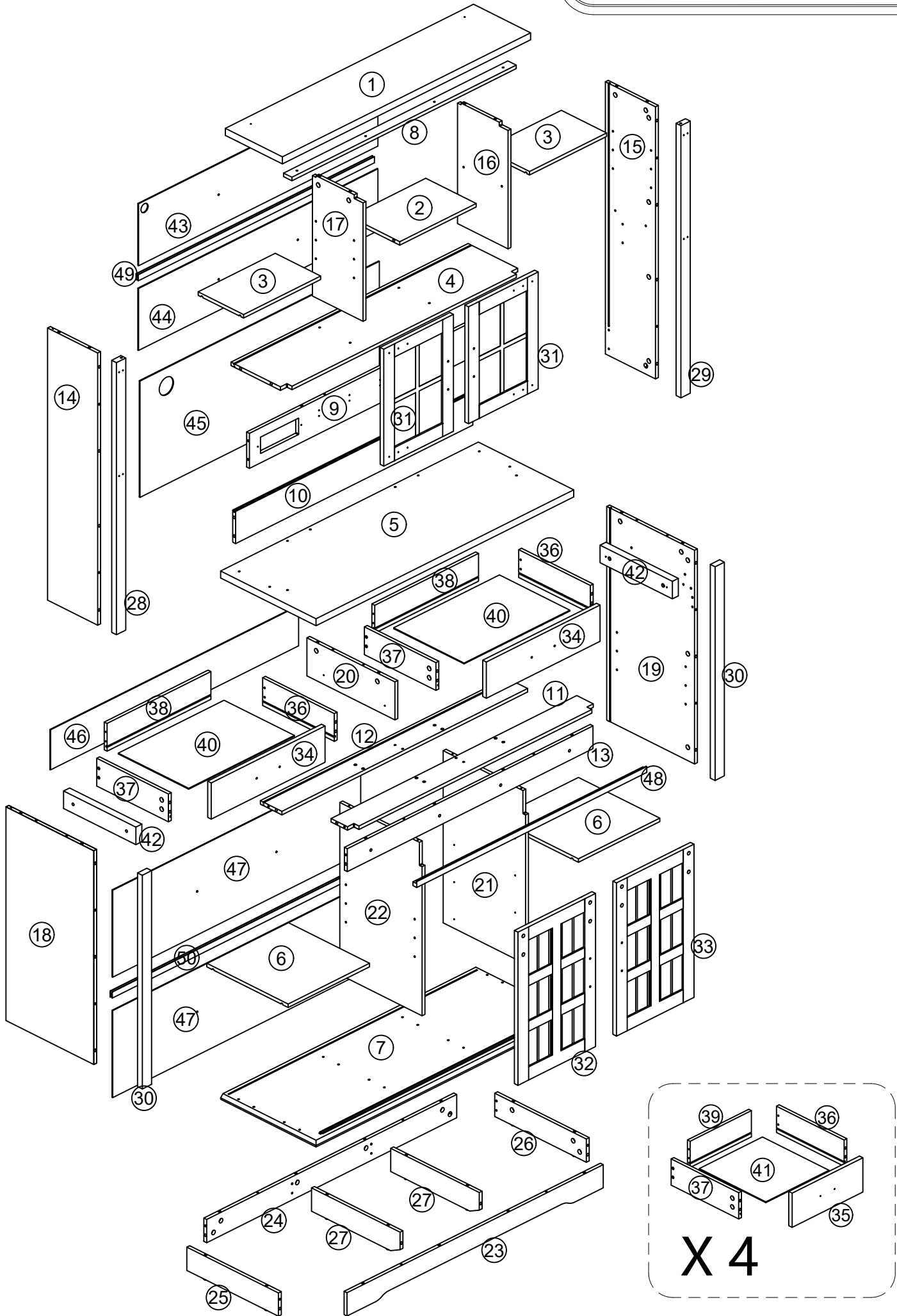

BOX-1/3 SKU N635P420194

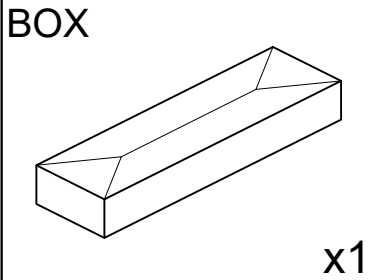
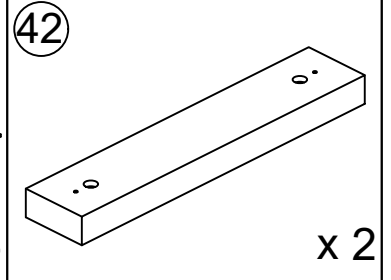
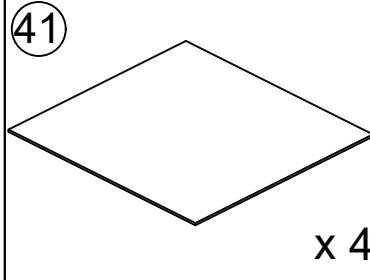
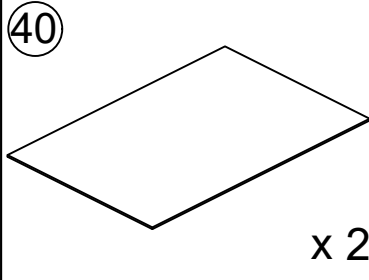
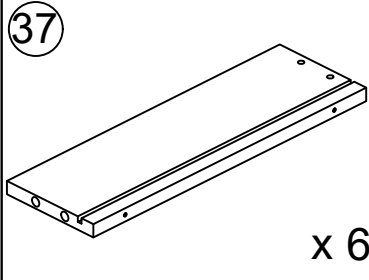
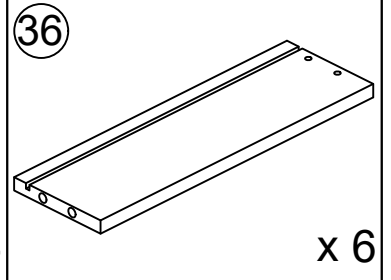
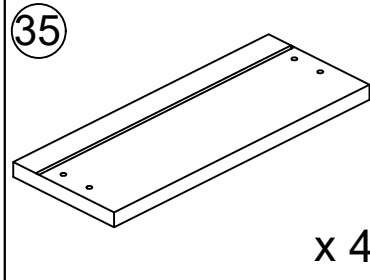
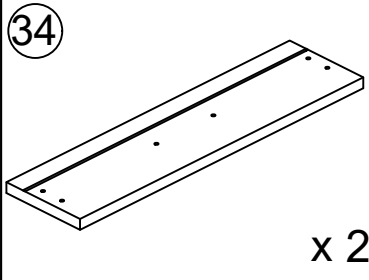
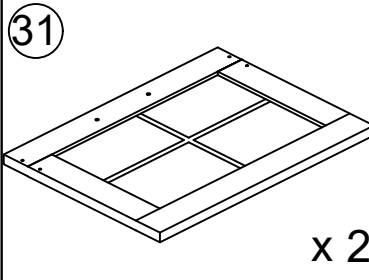
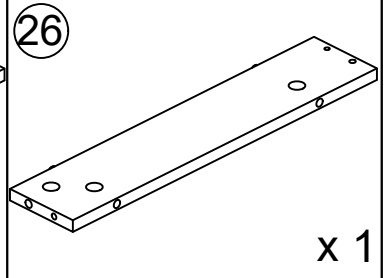
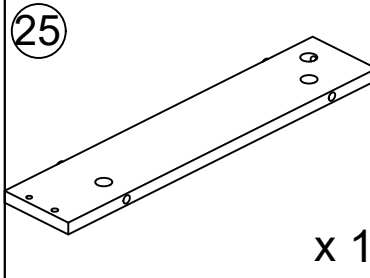
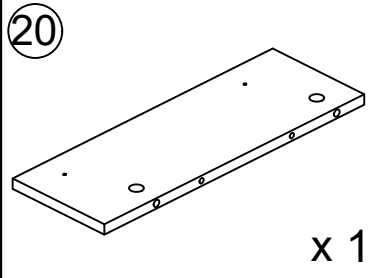
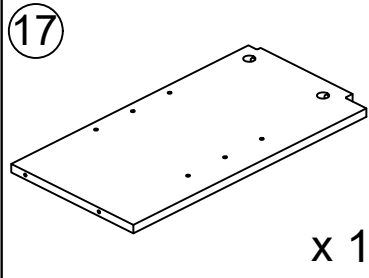
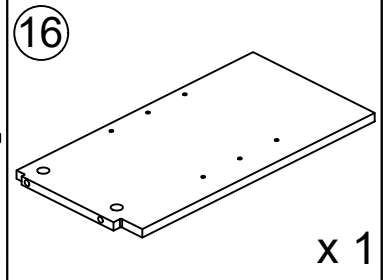
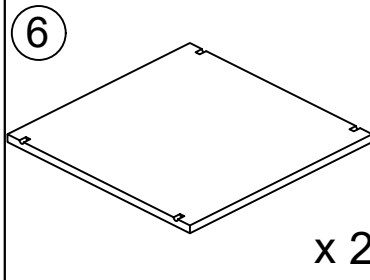
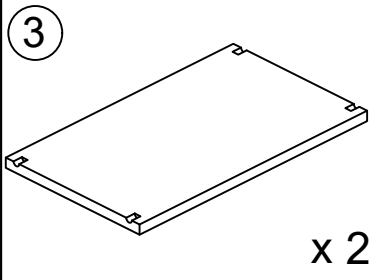
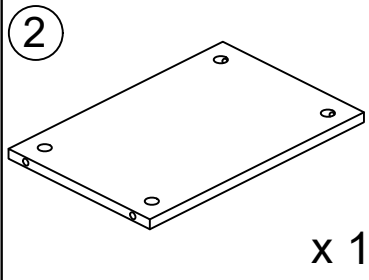

BOX-2/3 SKU N635P420193

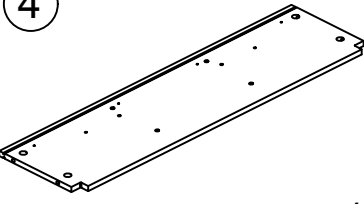
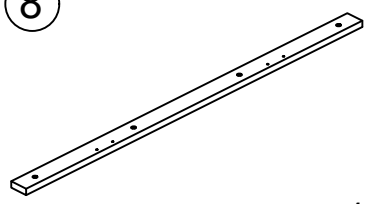
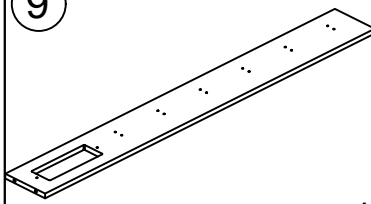
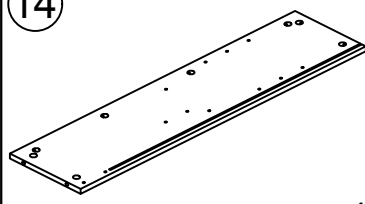
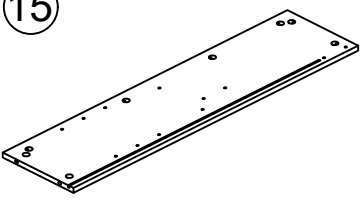
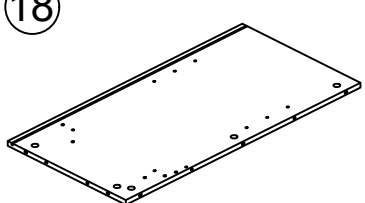
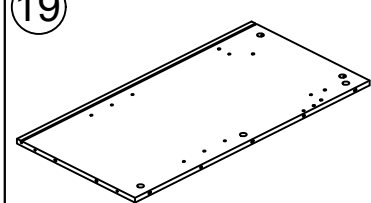
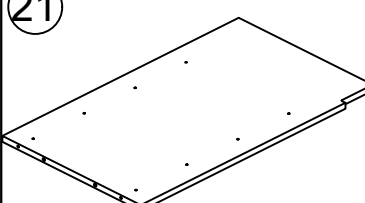
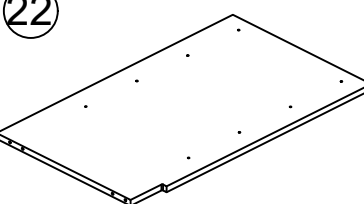
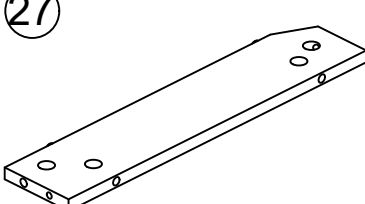
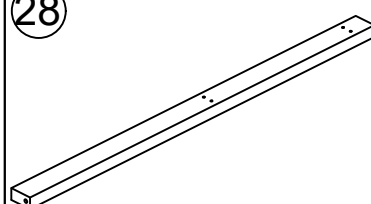
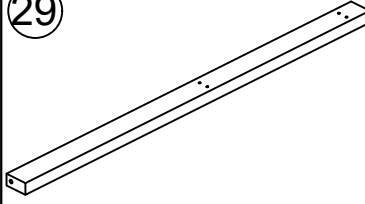
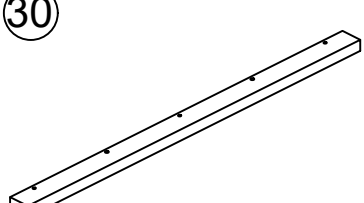
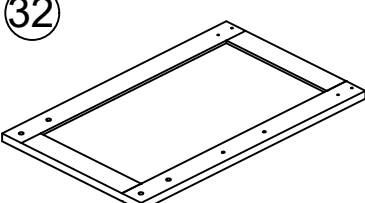
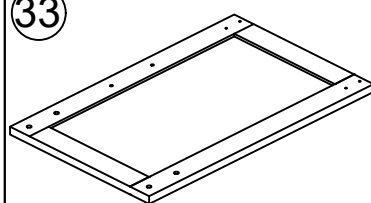

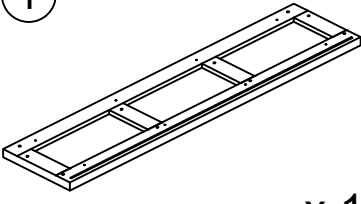
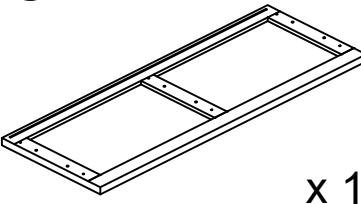
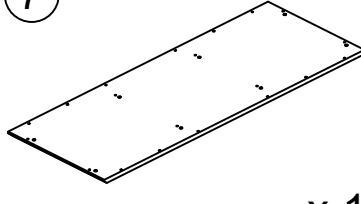
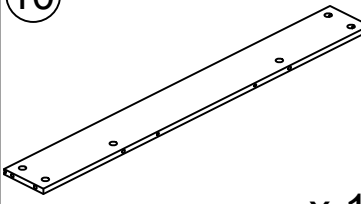
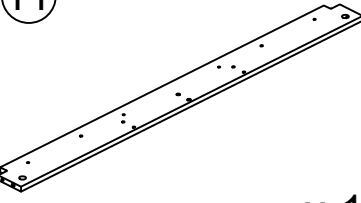
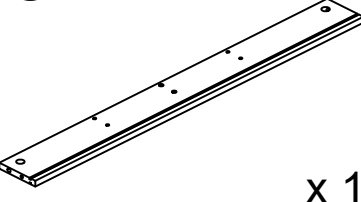
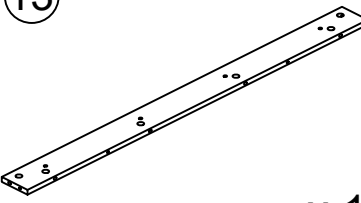
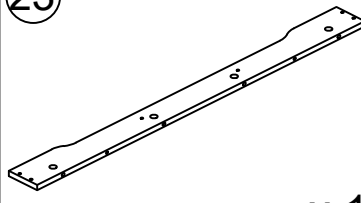
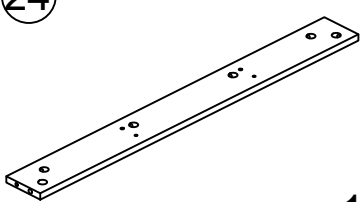
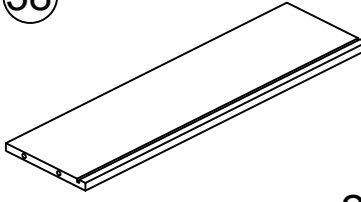
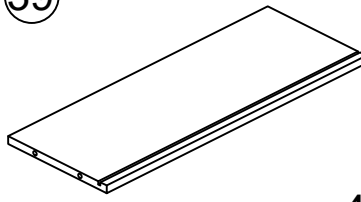
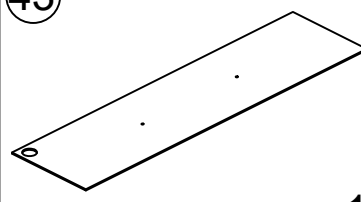
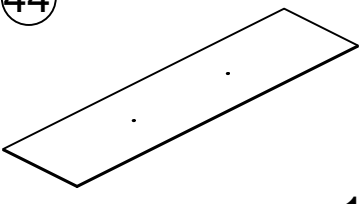
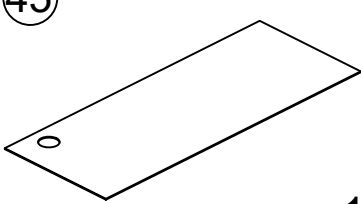
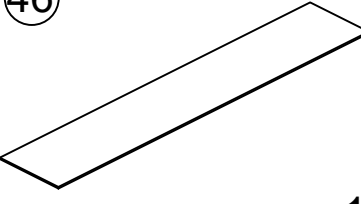
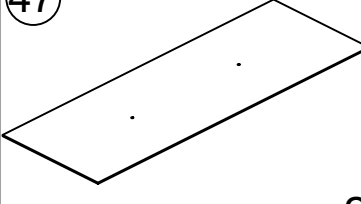
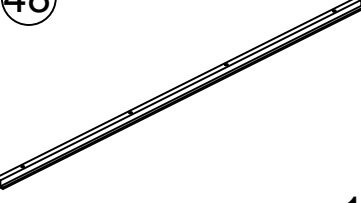
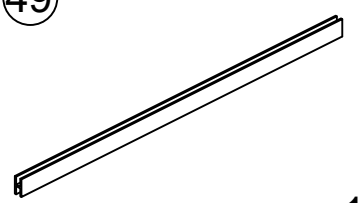
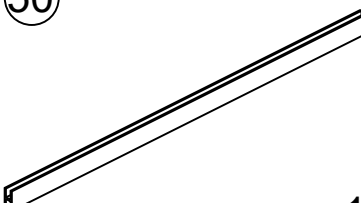

<p>④</p>  <p>x 1</p>	<p>⑧</p>  <p>x 1</p>	<p>⑨</p>  <p>x 1</p>	<p>⑭</p>  <p>x 1</p>
<p>⑮</p>  <p>x 1</p>	<p>⑱</p>  <p>x 1</p>	<p>⑲</p>  <p>x 1</p>	<p>⑳</p>  <p>x 1</p>
<p>㉒</p>  <p>x 1</p>	<p>㉗</p>  <p>x 2</p>	<p>㉘</p>  <p>x 1</p>	<p>㉙</p>  <p>x 1</p>
<p>㉓</p>  <p>x 2</p>	<p>㉛</p>  <p>x 1</p>	<p>㉜</p>  <p>x 1</p>	

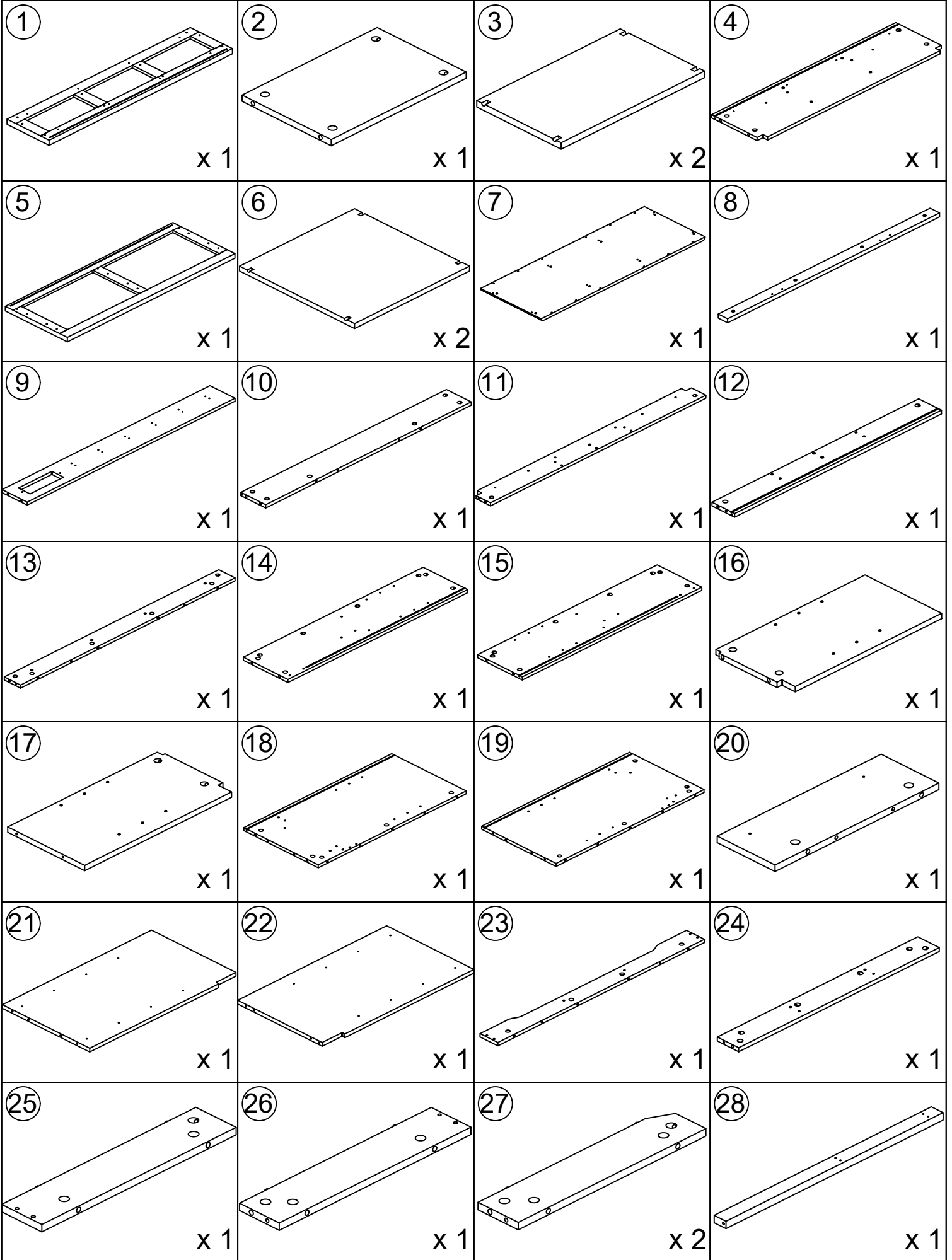
BOX-3/3 SKU N635P420192

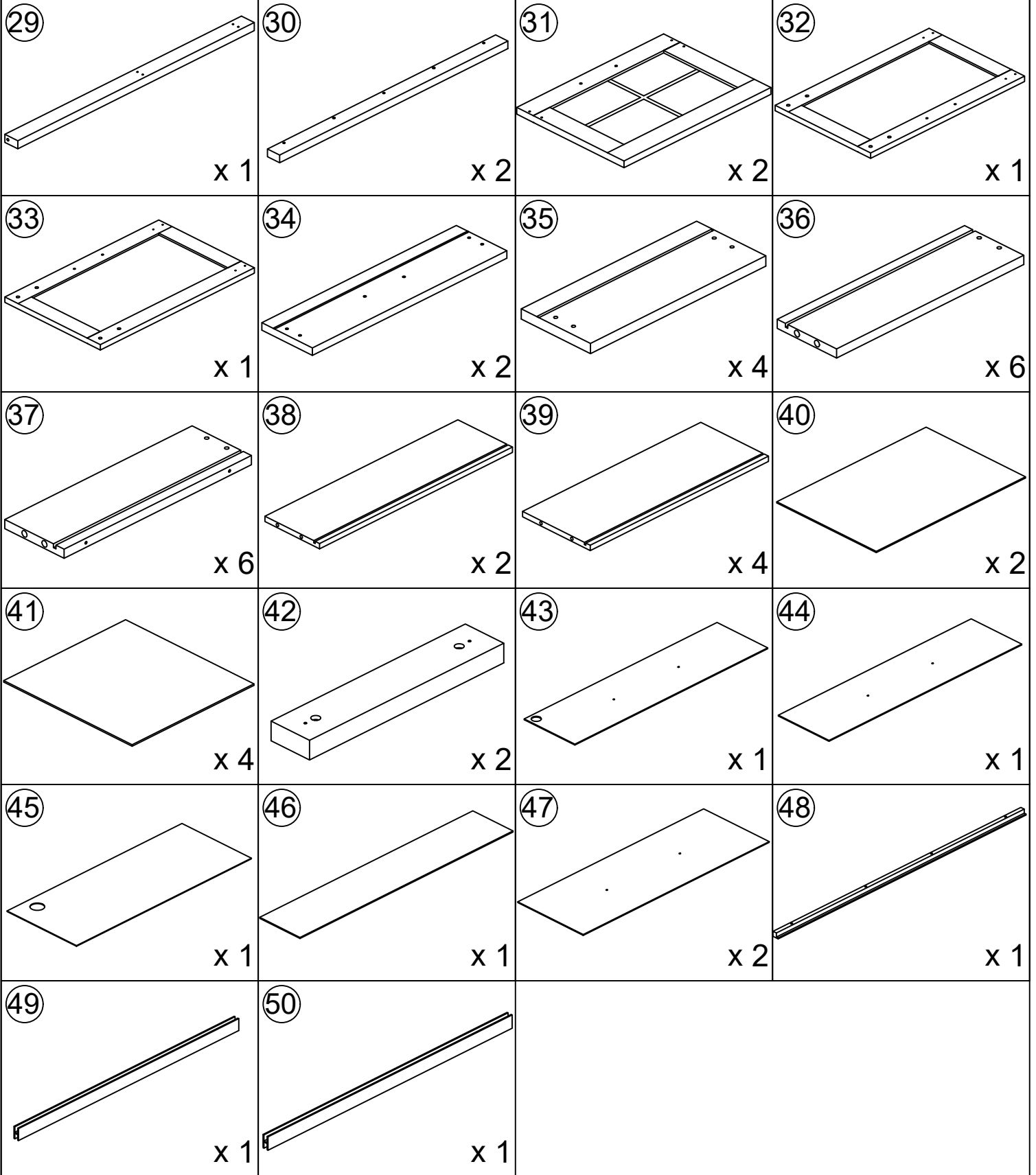
<p>①</p>  <p>x 1</p>	<p>⑤</p>  <p>x 1</p>	<p>⑦</p>  <p>x 1</p>	<p>⑩</p>  <p>x 1</p>
<p>⑪</p>  <p>x 1</p>	<p>⑫</p>  <p>x 1</p>	<p>⑬</p>  <p>x 1</p>	<p>⑳</p>  <p>x 1</p>
<p>㉔</p>  <p>x 1</p>	<p>㉟</p>  <p>x 2</p>	<p>㉠</p>  <p>x 4</p>	<p>㉡</p>  <p>x 1</p>
<p>㉢</p>  <p>x 1</p>	<p>㉣</p>  <p>x 1</p>	<p>㉤</p>  <p>x 1</p>	<p>㉥</p>  <p>x 2</p>
<p>㉦</p>  <p>x 1</p>	<p>㉧</p>  <p>x 1</p>	<p>㉨</p>  <p>x 1</p>	

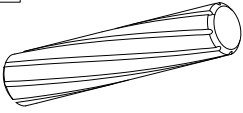
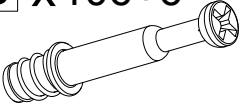
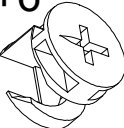
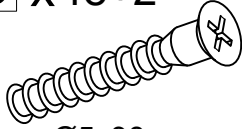
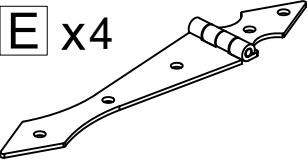
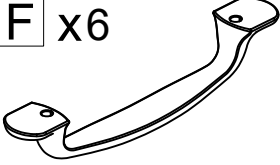
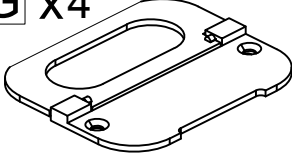
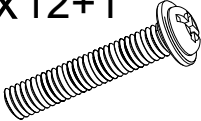
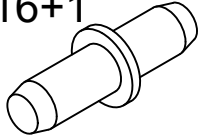
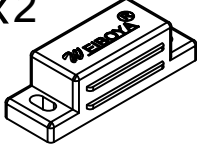
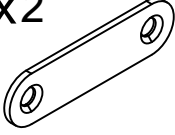
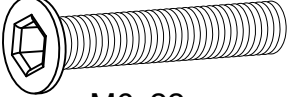
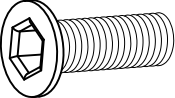

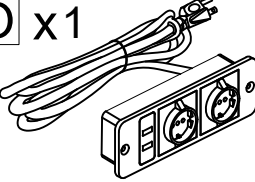
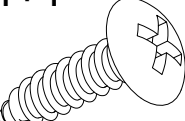
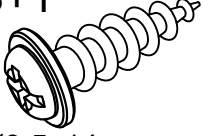
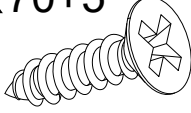

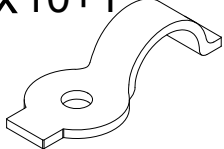
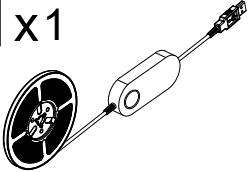
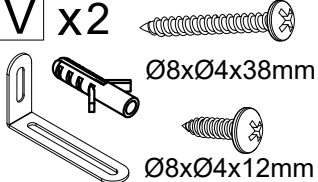
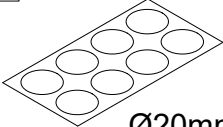
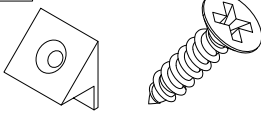
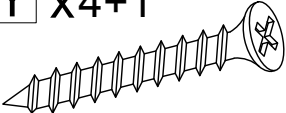
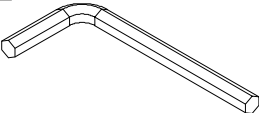
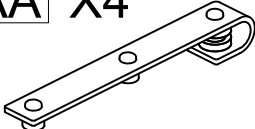
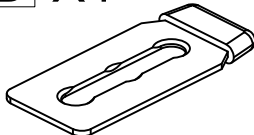
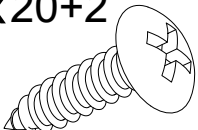
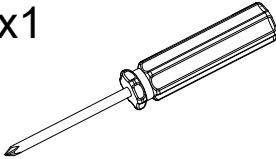
<p><b>A</b> x52+2</p>  <p>Ø6x30mm</p>	<p><b>B</b> x106+6</p>  <p>Ø6x35mm</p>	<p><b>C</b> x106+6</p>  <p>Ø15x10mm</p>	<p><b>D</b> x48+2</p>  <p>Ø5x38mm</p>
<p><b>E</b> x4</p>  <p>142x24x6mm</p>	<p><b>F</b> x6</p> 	<p><b>G</b> x4</p> 	<p><b>H</b> x12+1</p>  <p>M4x18mm</p>
<p><b>I</b> x16+1</p>  <p>Ø5x17mm</p>	<p><b>J</b> x2</p> 	<p><b>K</b> x2</p>  <p>45x12x1.3mm</p>	<p><b>L</b> x8+1</p>  <p>M6x22mm</p>
<p><b>M</b> x8+1</p>  <p>M6x12mm</p>	<p><b>N</b> x6</p> 	<p><b>O</b> x1</p> 	<p><b>P</b> x4+1</p>  <p>Ø6xØ3x14mm</p>
<p><b>Q</b> x8+1</p>  <p>Ø7xØ3.5x14mm</p>	<p><b>R</b> x70+5</p>  <p>Ø6xØ3x12mm</p>	<p><b>S</b> x22+2</p>  <p>Ø7xØ3.5x14mm</p>	<p><b>T</b> x10+1</p> 
<p><b>U</b> x1</p> 	<p><b>V</b> x2</p>  <p>Ø8xØ4x38mm Ø8xØ4x12mm</p>	<p><b>W</b> x106+6</p>  <p>Ø20mm</p>	<p><b>X</b> x34+2</p>  <p>Ø6xØ3x16mm</p>
<p><b>Y</b> x4+1</p>  <p>Ø8xØ4x25mm</p>	<p><b>Z</b> x1</p>  <p>4mm</p>	<p><b>AA</b> X4</p> 	<p><b>BB</b> X4</p> 
<p><b>CC</b> x20+2</p>  <p>Ø8xØ4x14mm</p>	<p>x1</p> 	<p><b>L=300 X 6</b></p>	

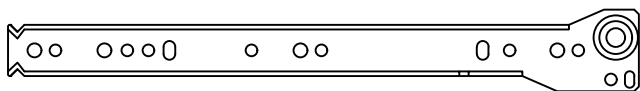

**CL**

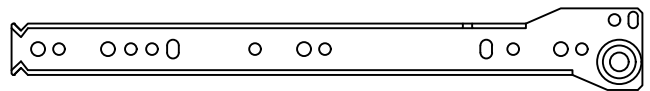

**CR**

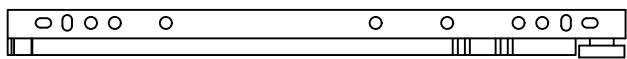

**DL**

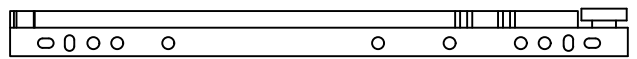

**DR**

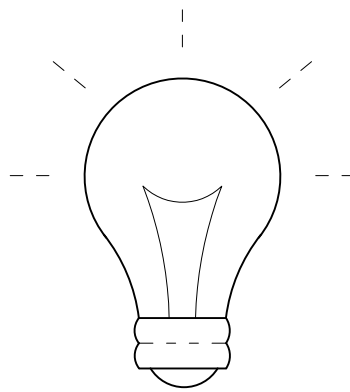

## friendly reminder

To avoid errors and confusion during the installation of accessories, use the type and quantity of hardware accessories according to the installation procedure described in the instructions. First, unroll the accessories bag and lay out the hardware accessories, cut holes in the side, and take out the hardware accessories

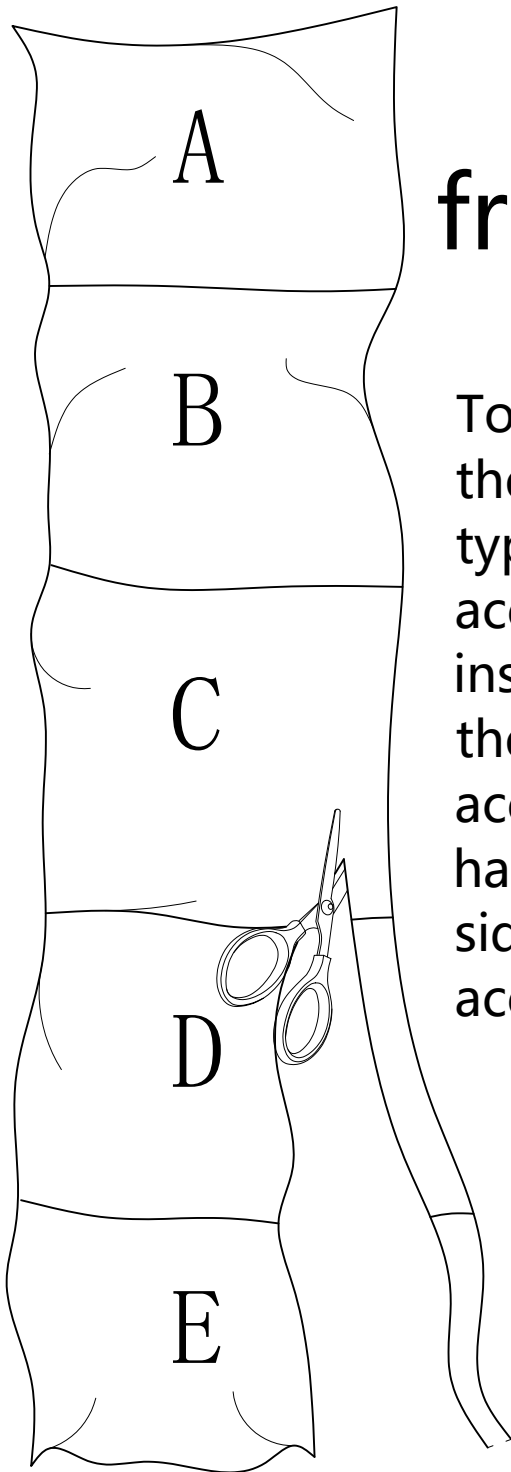

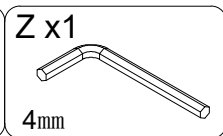
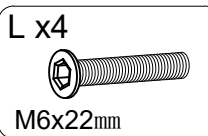
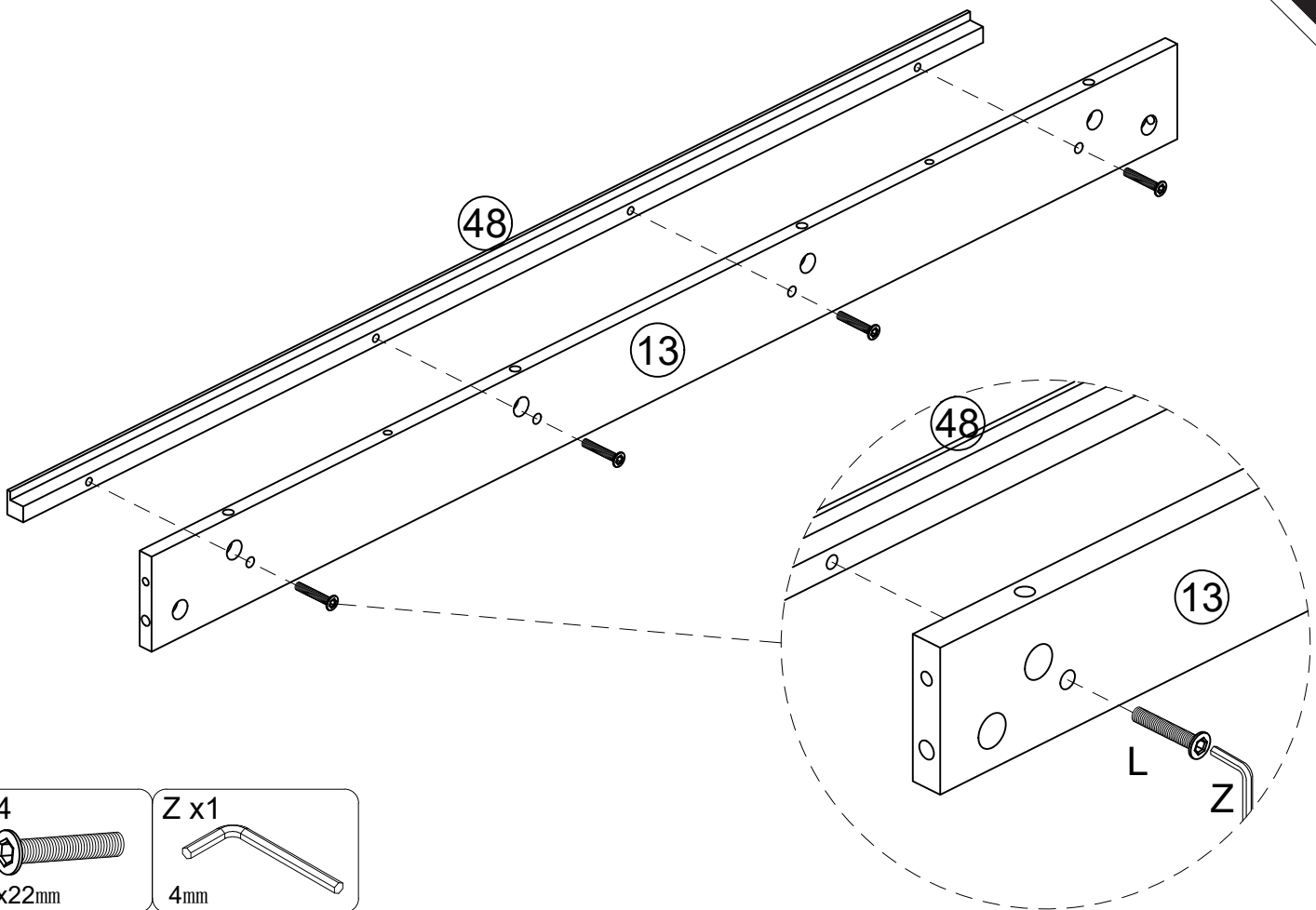
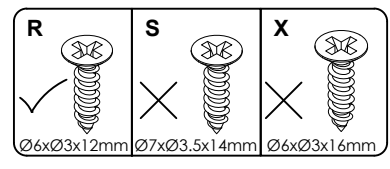
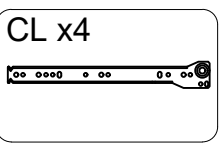
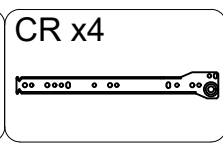
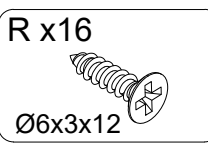
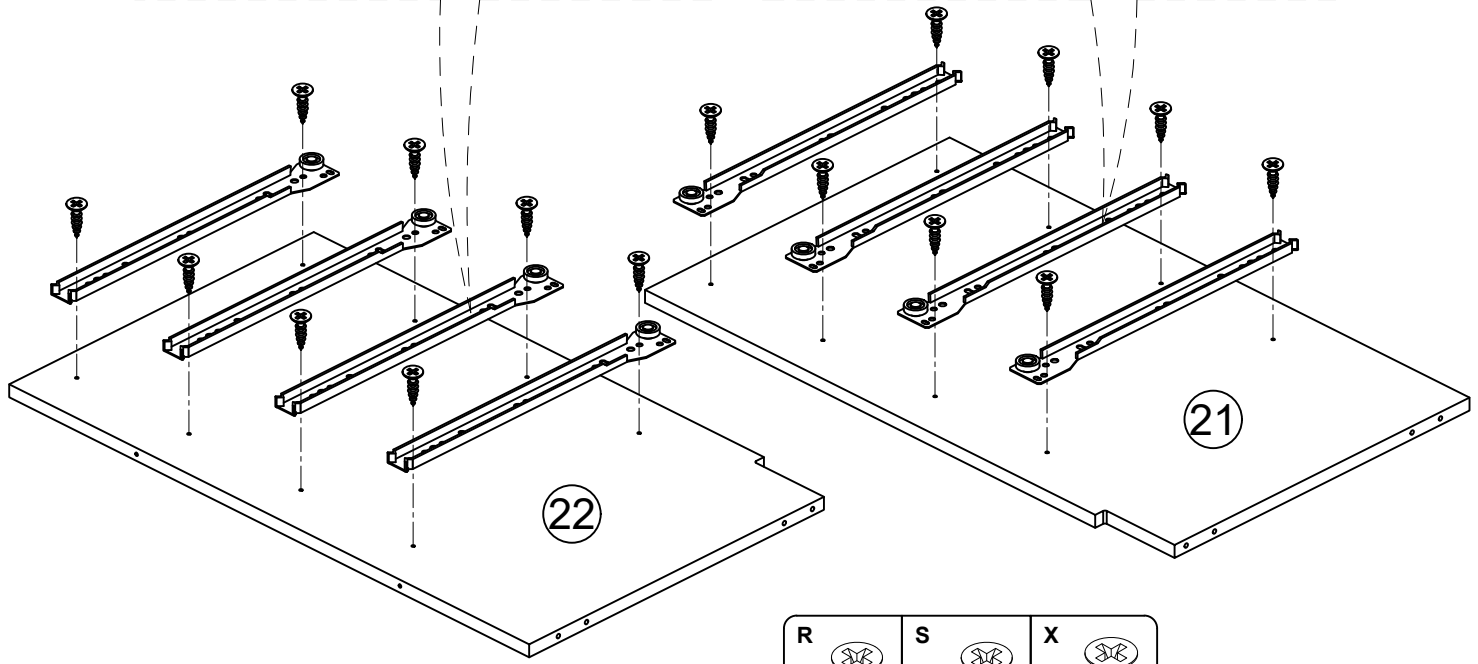
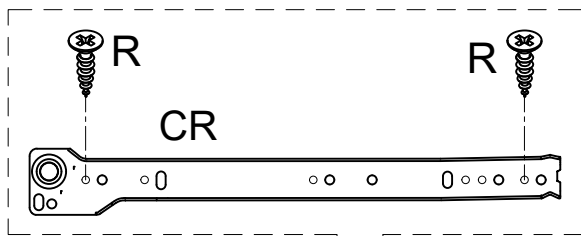
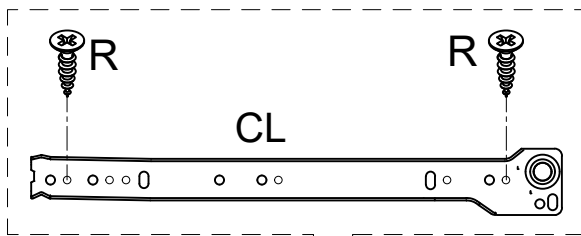

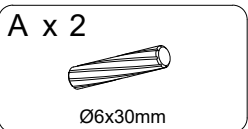
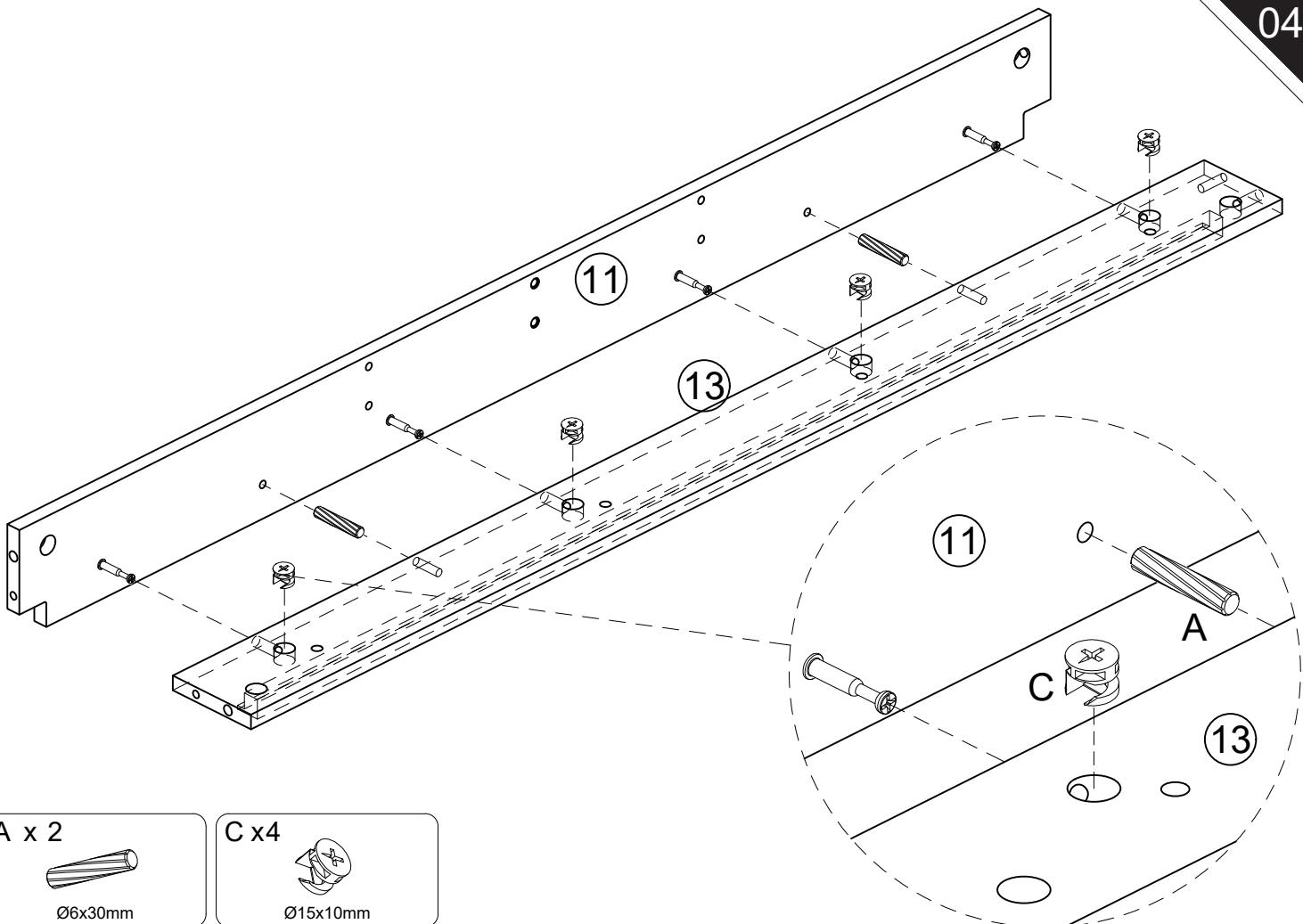
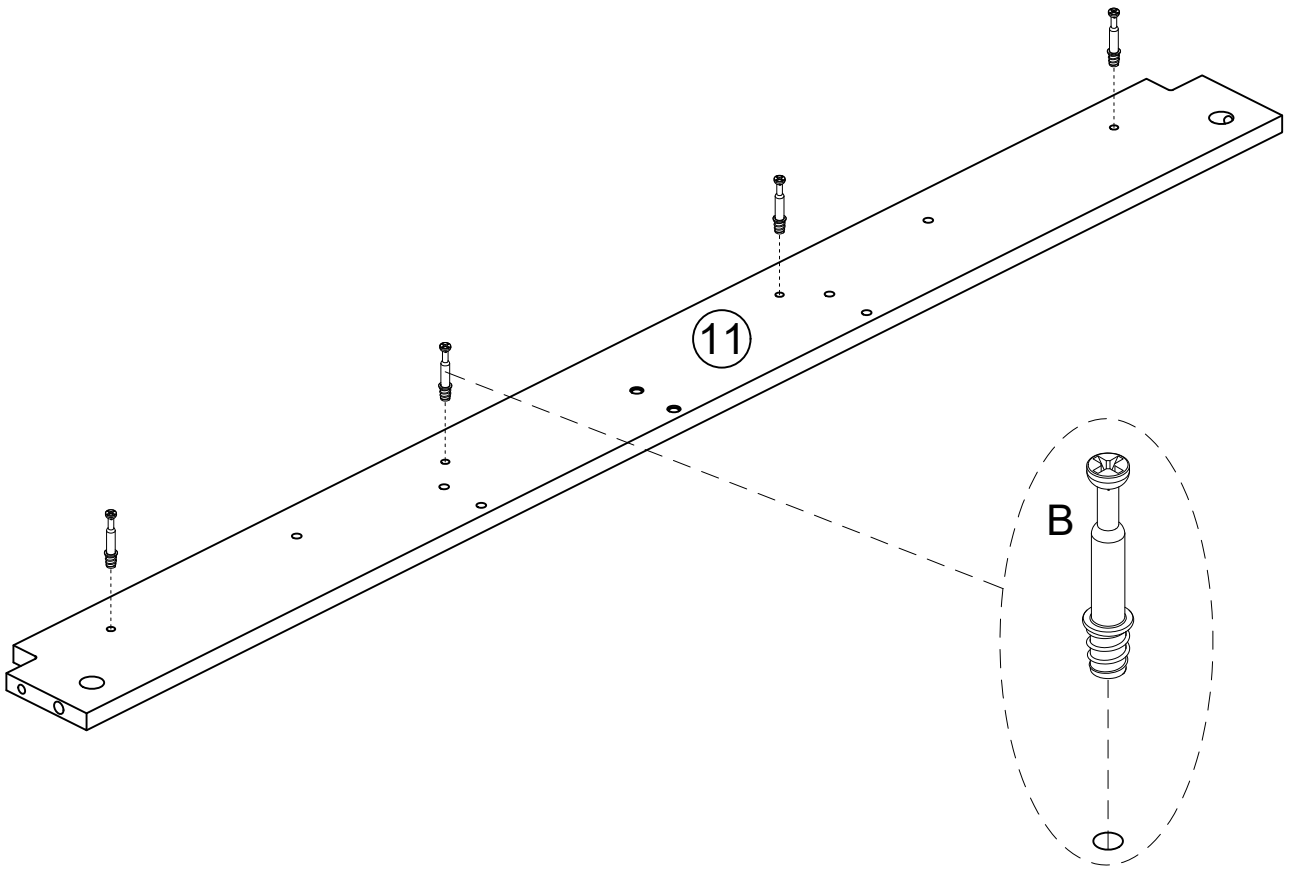

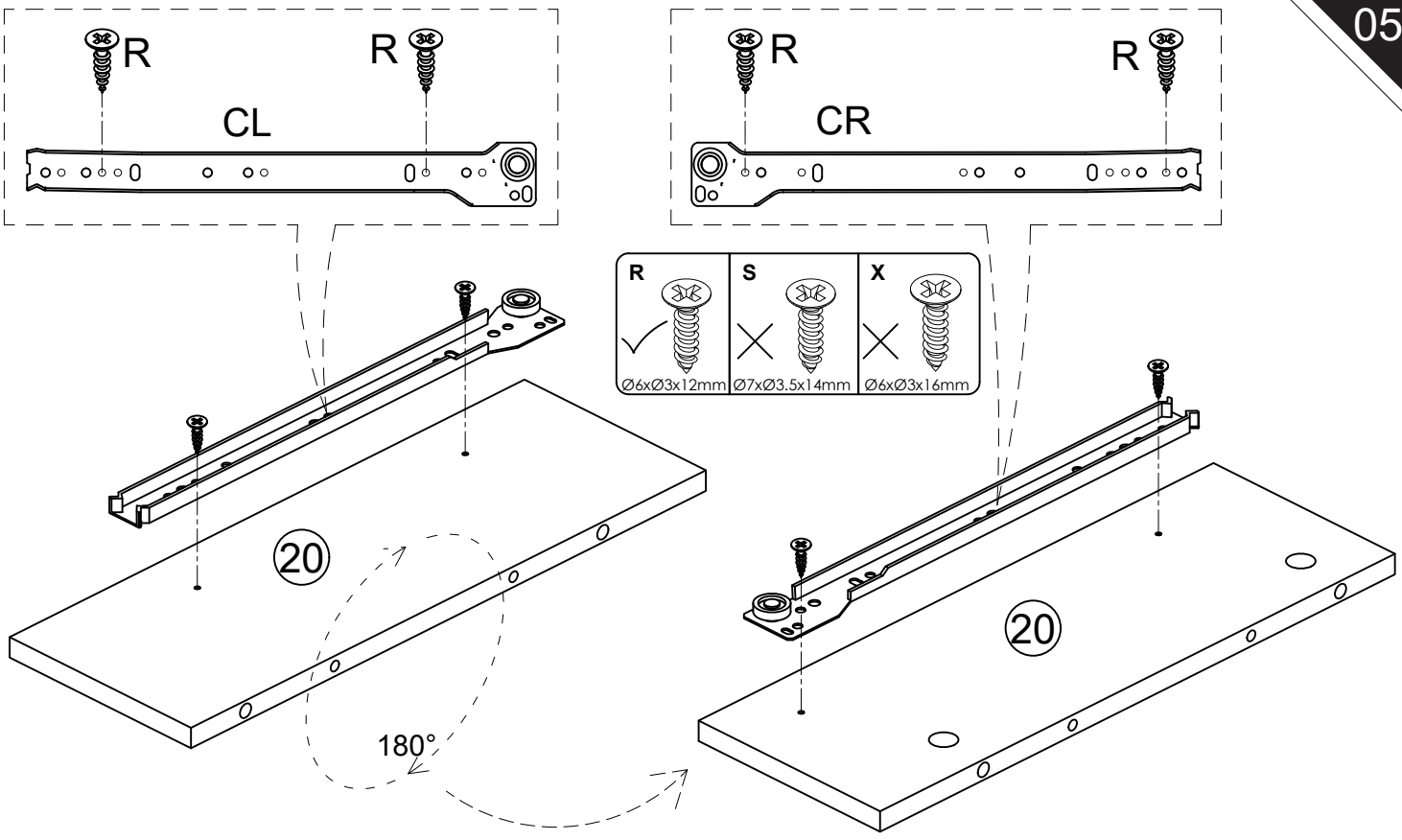

- R x4  
Ø6x3x12
- CR x1
- CL x1

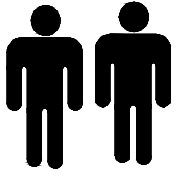
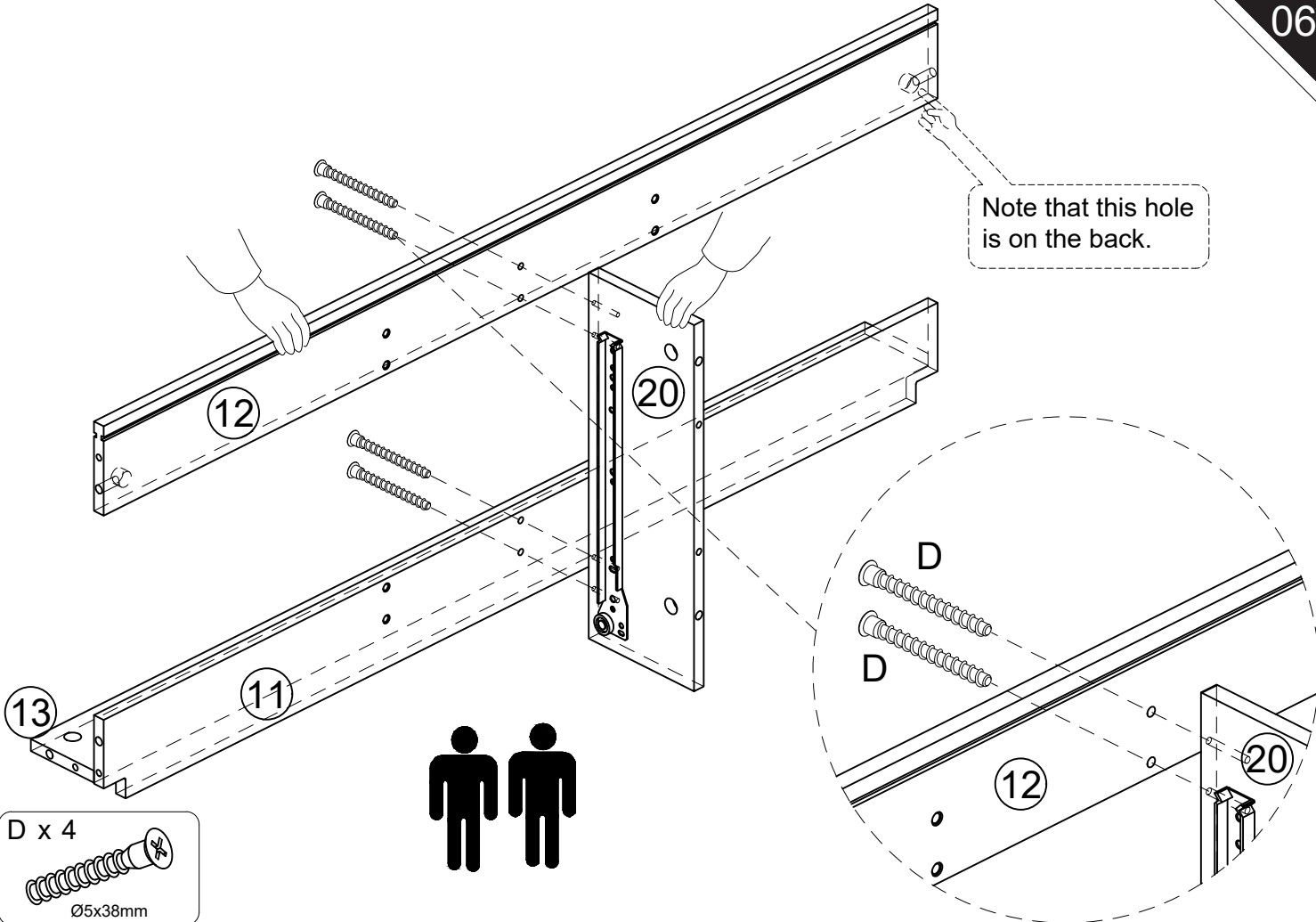

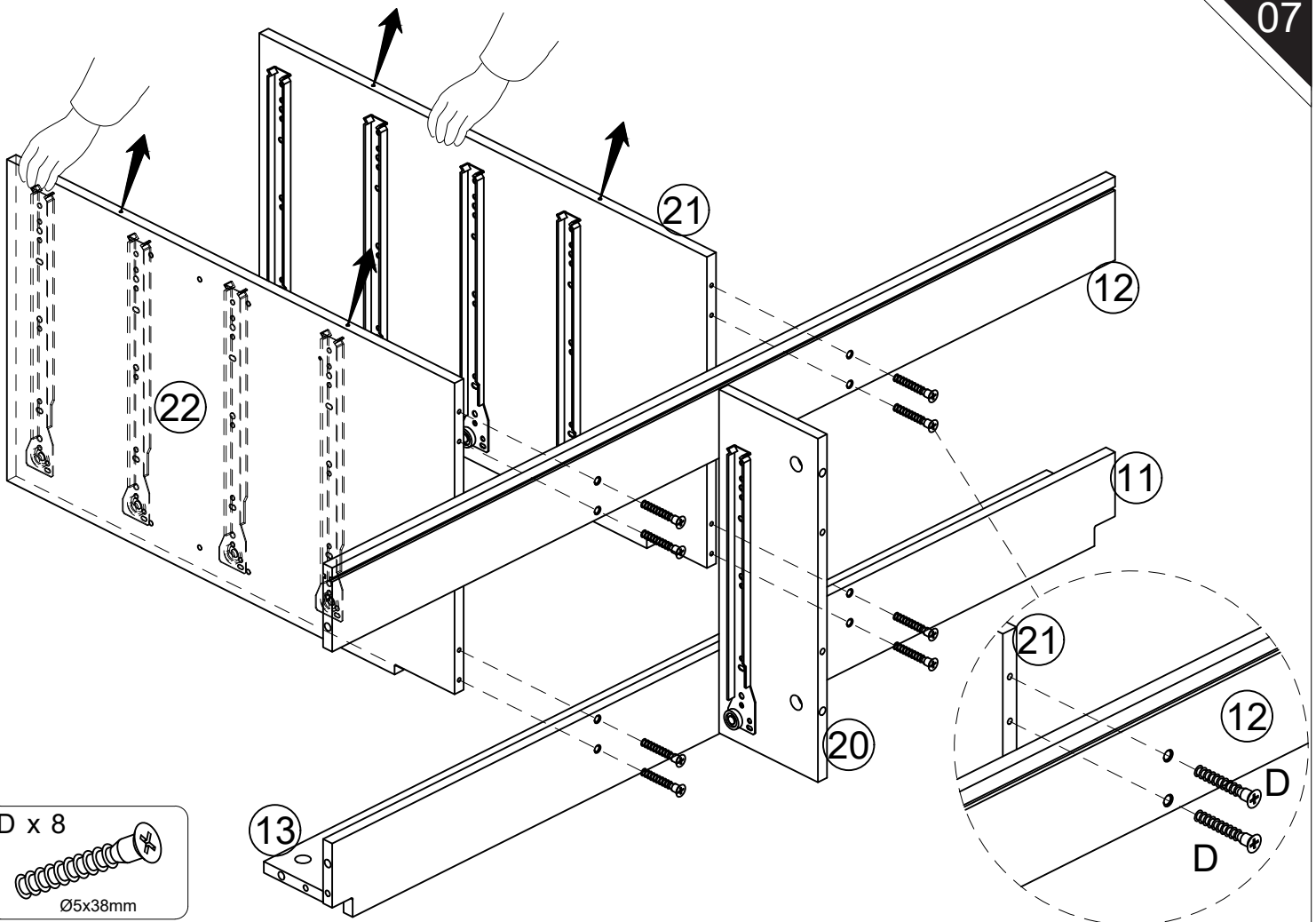

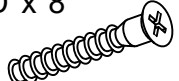
D x 8  
  
 Ø5x38mm

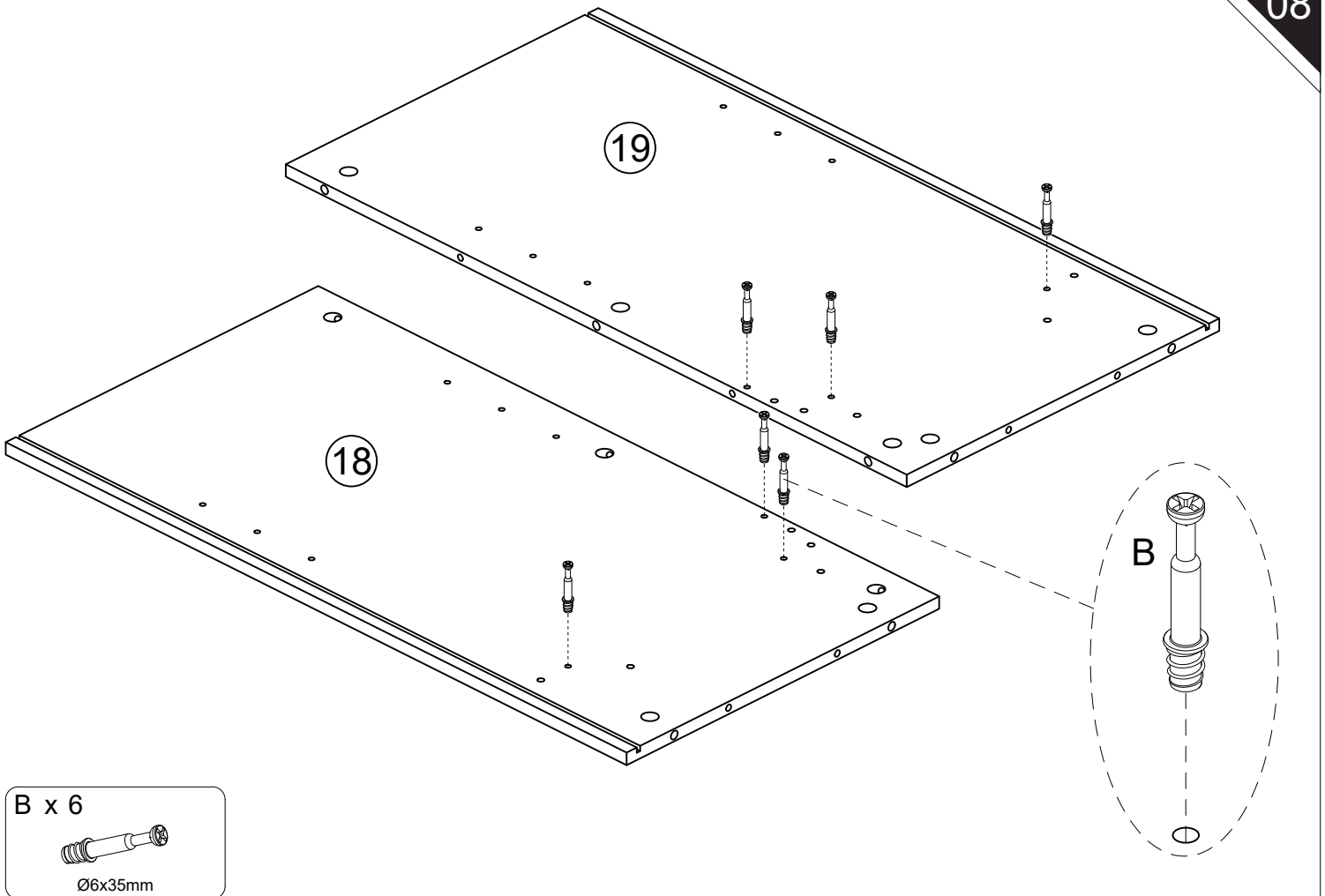

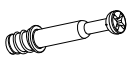
B x 6  
  
 Ø6x35mm

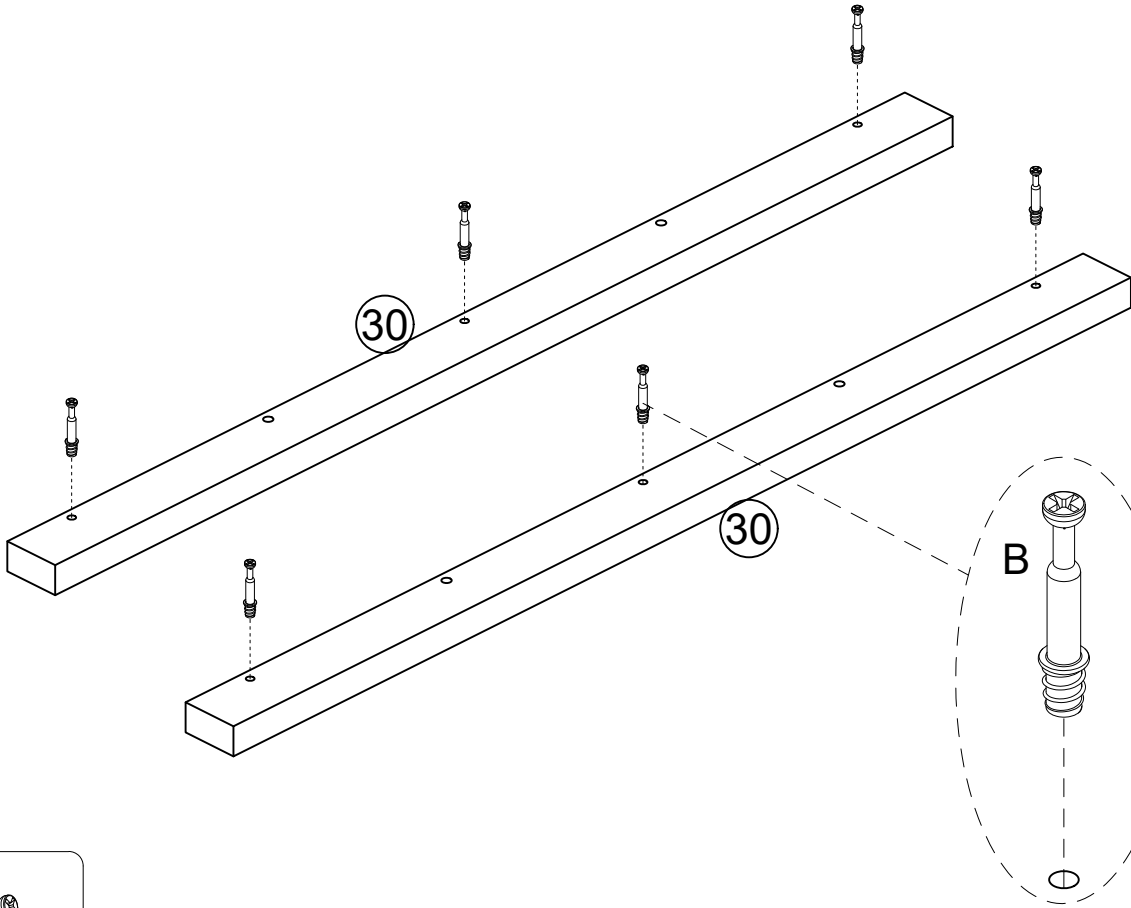

**B x 6**



Ø6x35mm

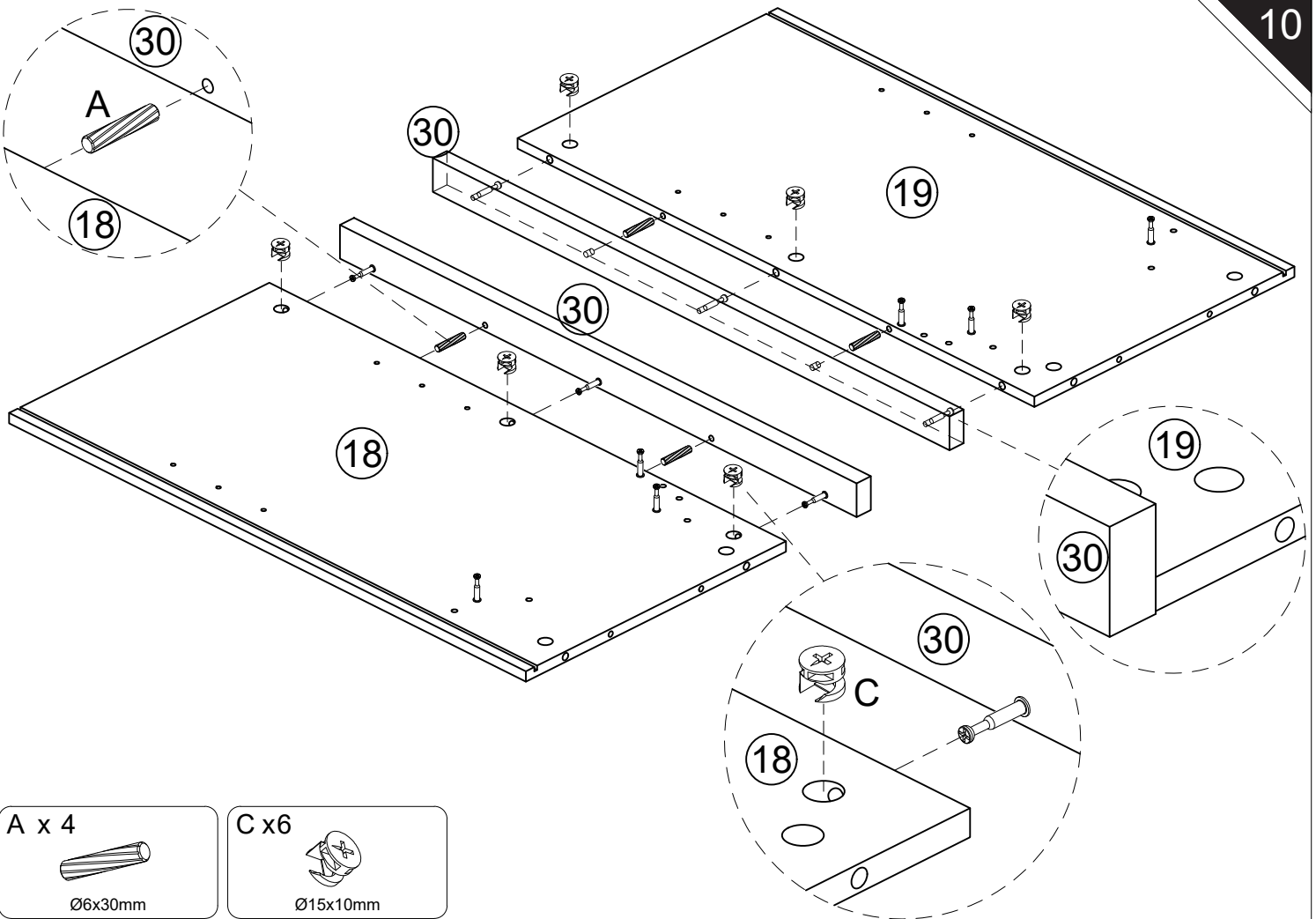

**A x 4**



Ø6x30mm

**C x 6**



Ø15x10mm

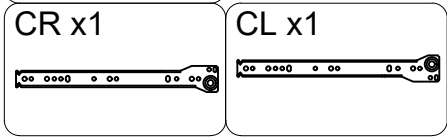
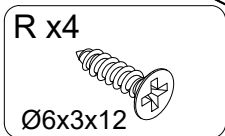
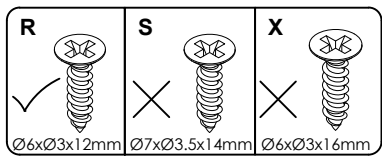
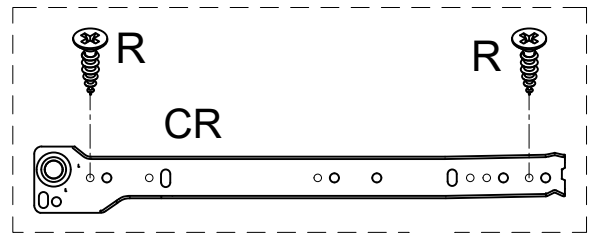
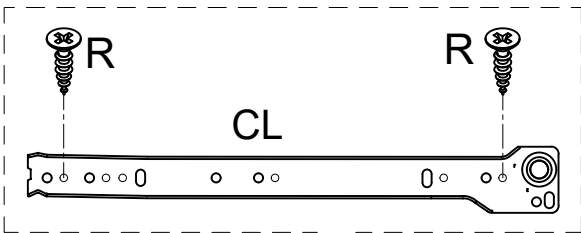
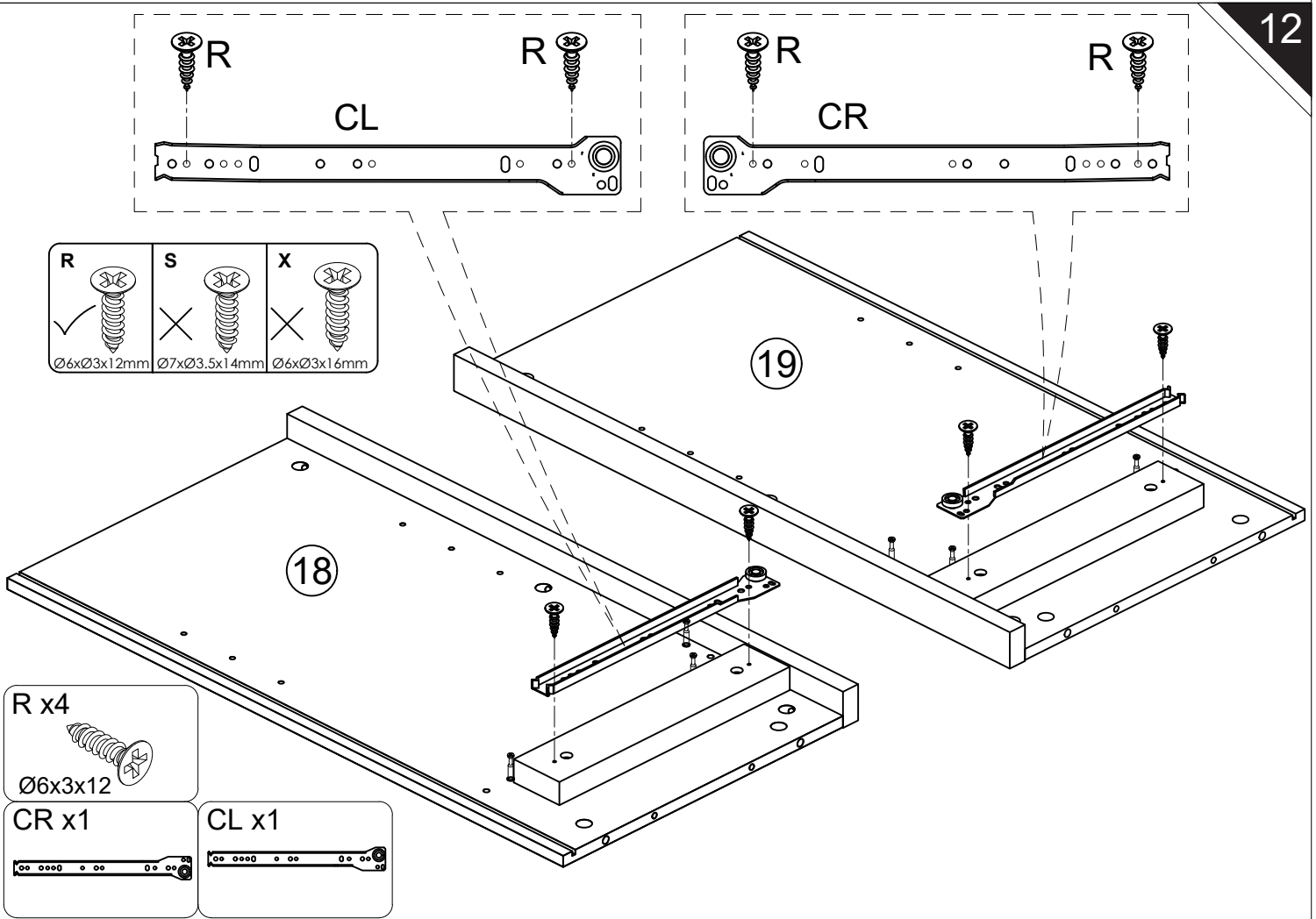
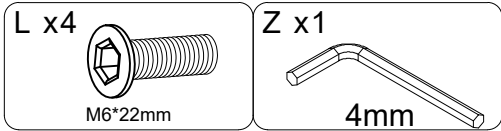
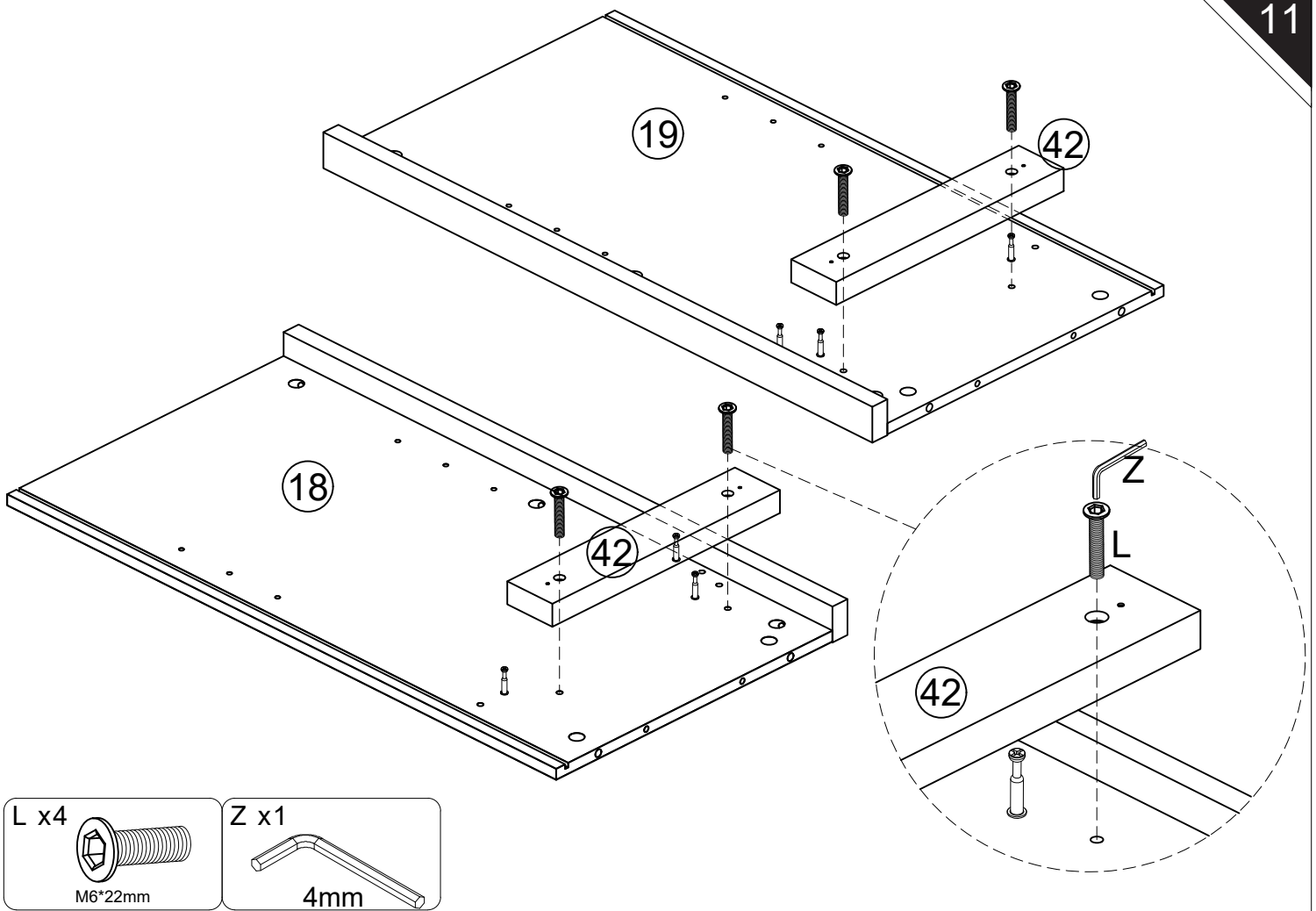

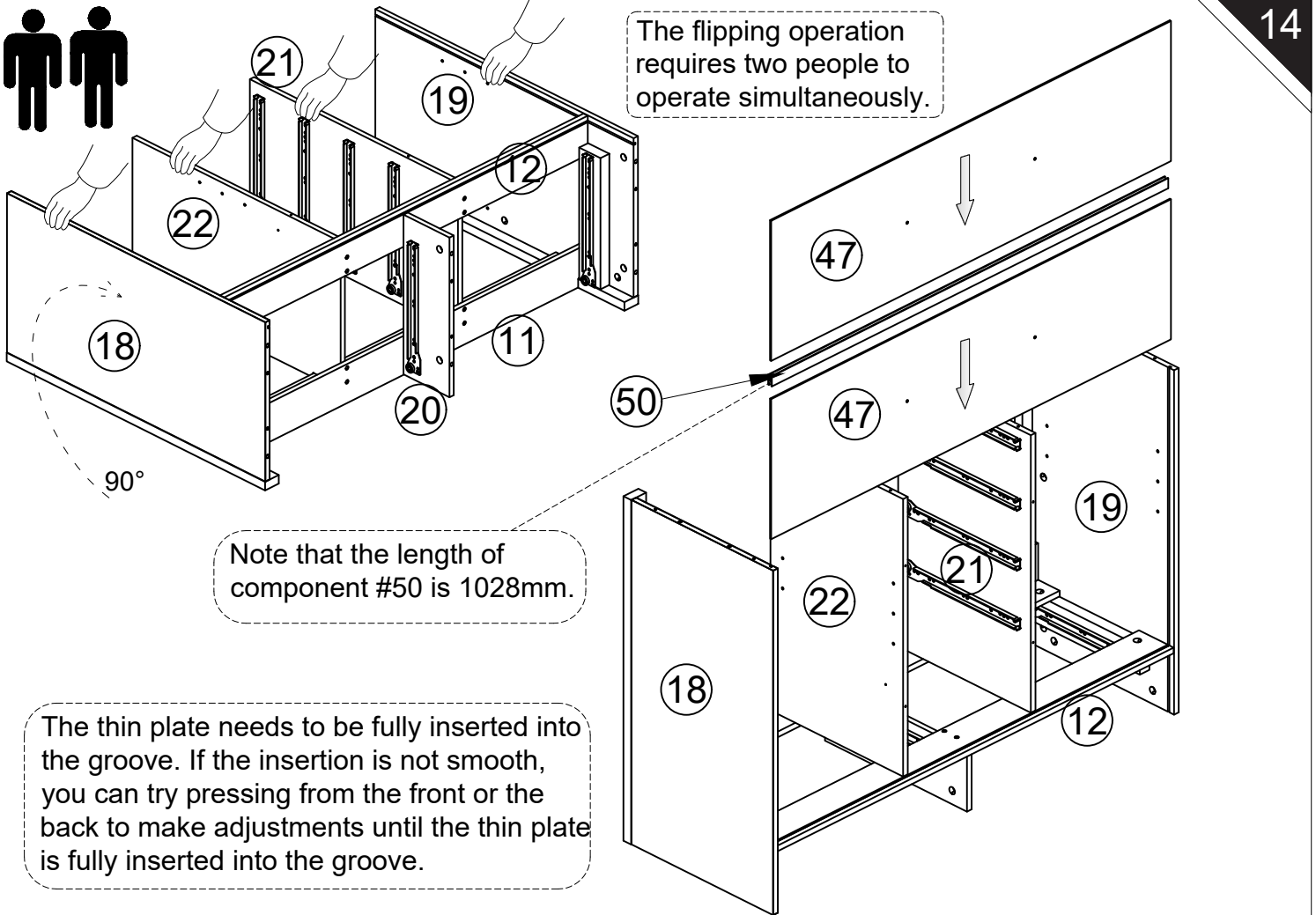
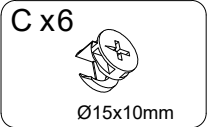
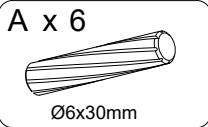
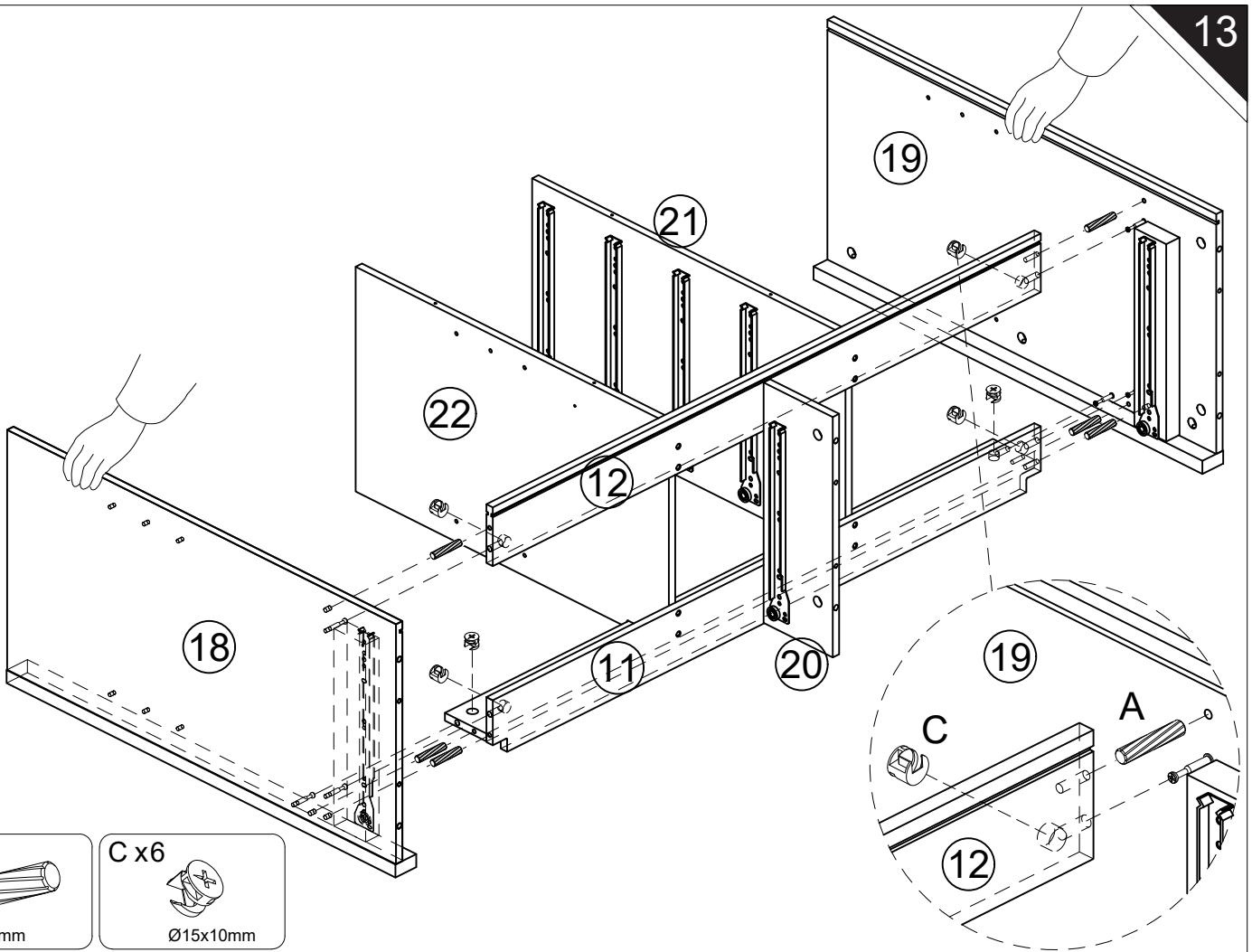

The flipping operation requires two people to operate simultaneously.

Note that the length of component #50 is 1028mm.

The thin plate needs to be fully inserted into the groove. If the insertion is not smooth, you can try pressing from the front or the back to make adjustments until the thin plate is fully inserted into the groove.

Note that the hypotenuse is located on the back panel here.

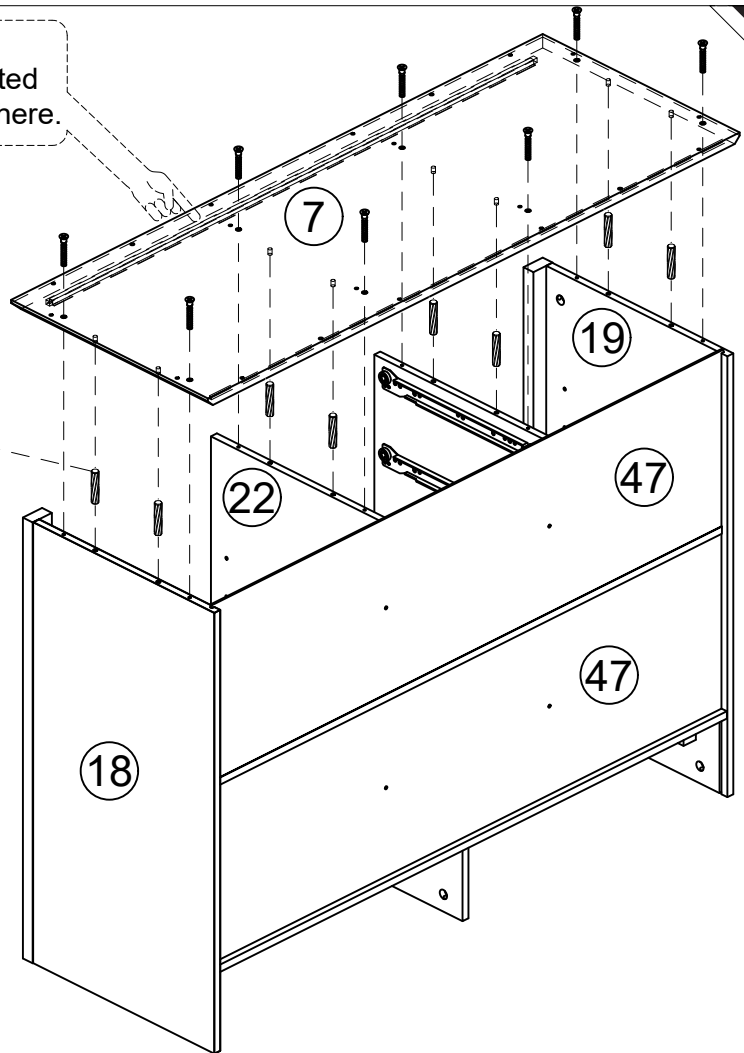
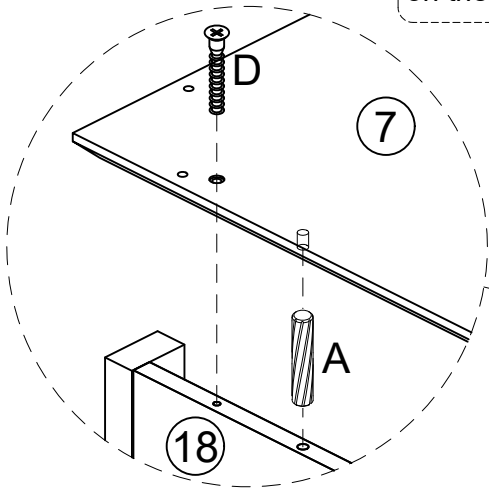

The thin plate needs to be fully inserted into the groove. If the insertion is not smooth, you can try pressing from the front or the back to make adjustments until the thin plate is fully inserted into the groove.

A x 8

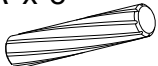

Ø6x30mm

D x 8



Ø5x38mm

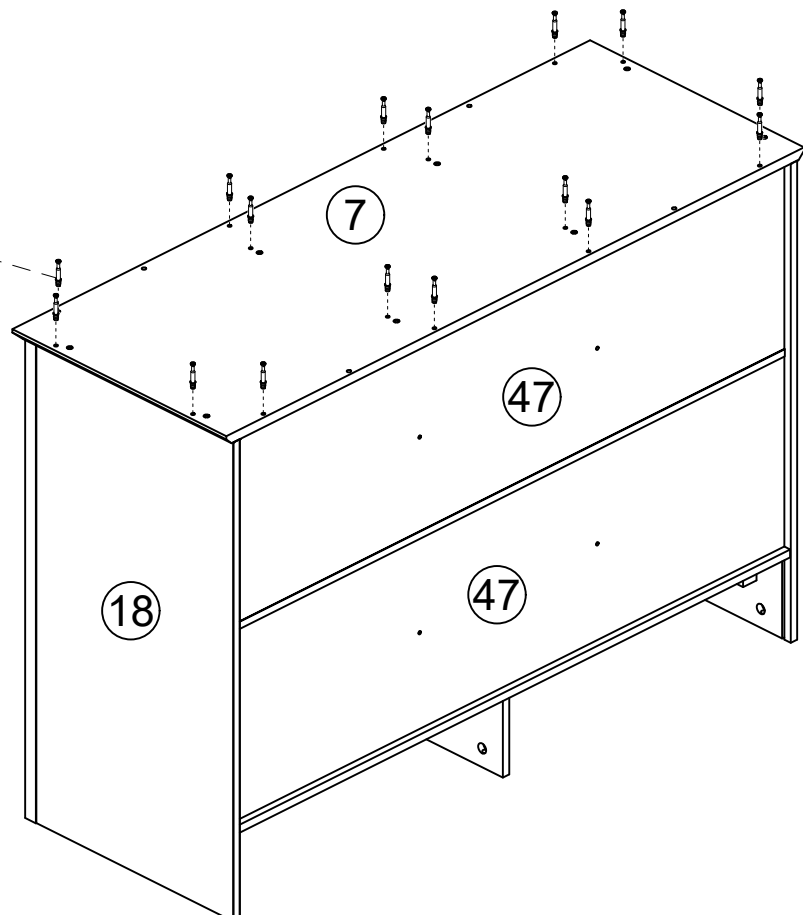
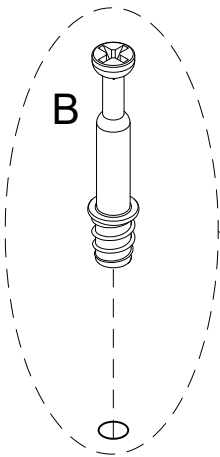

B x 16

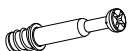

Ø6x35mm

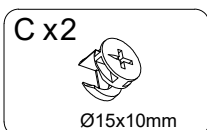
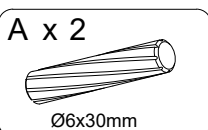
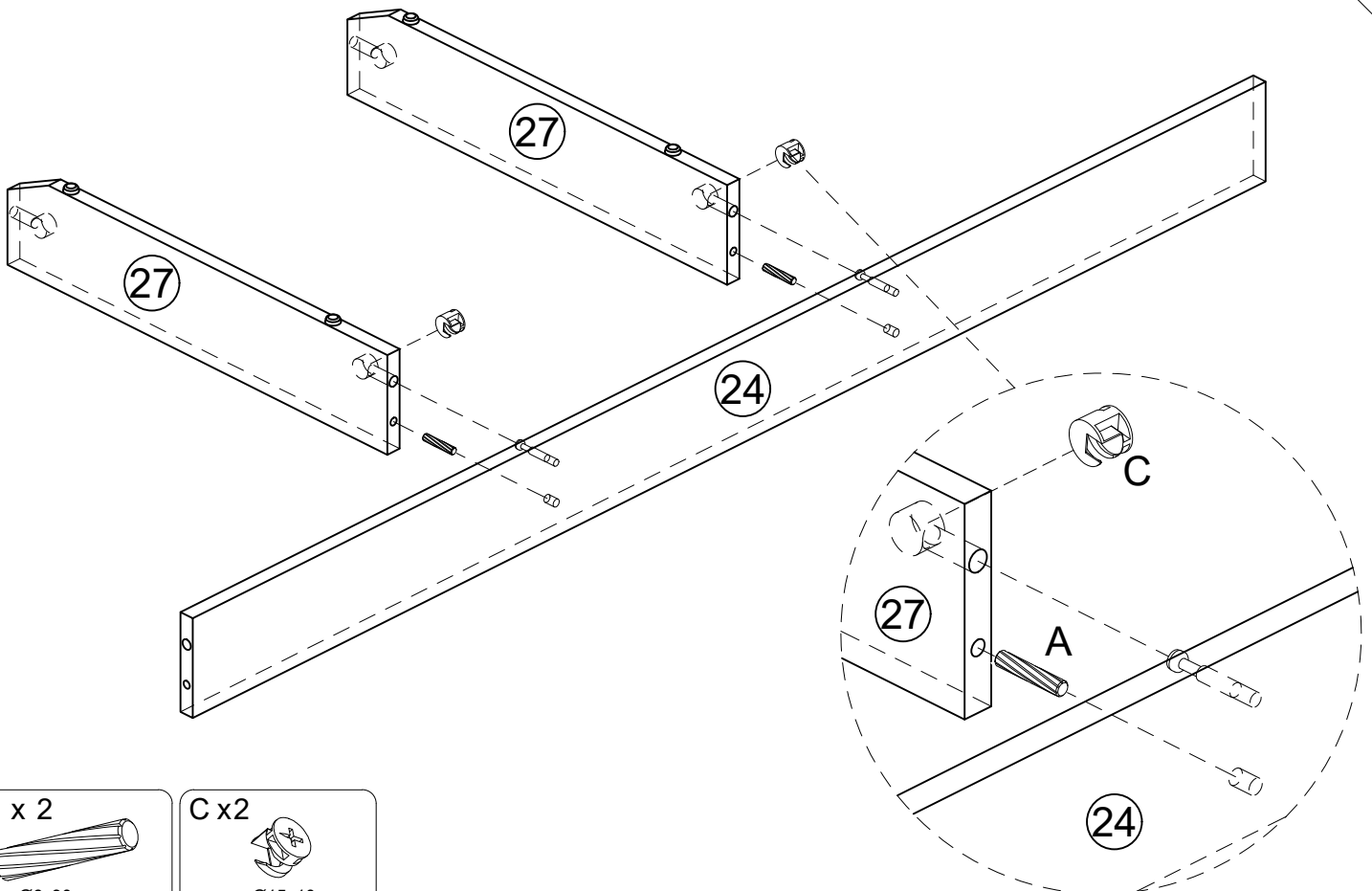
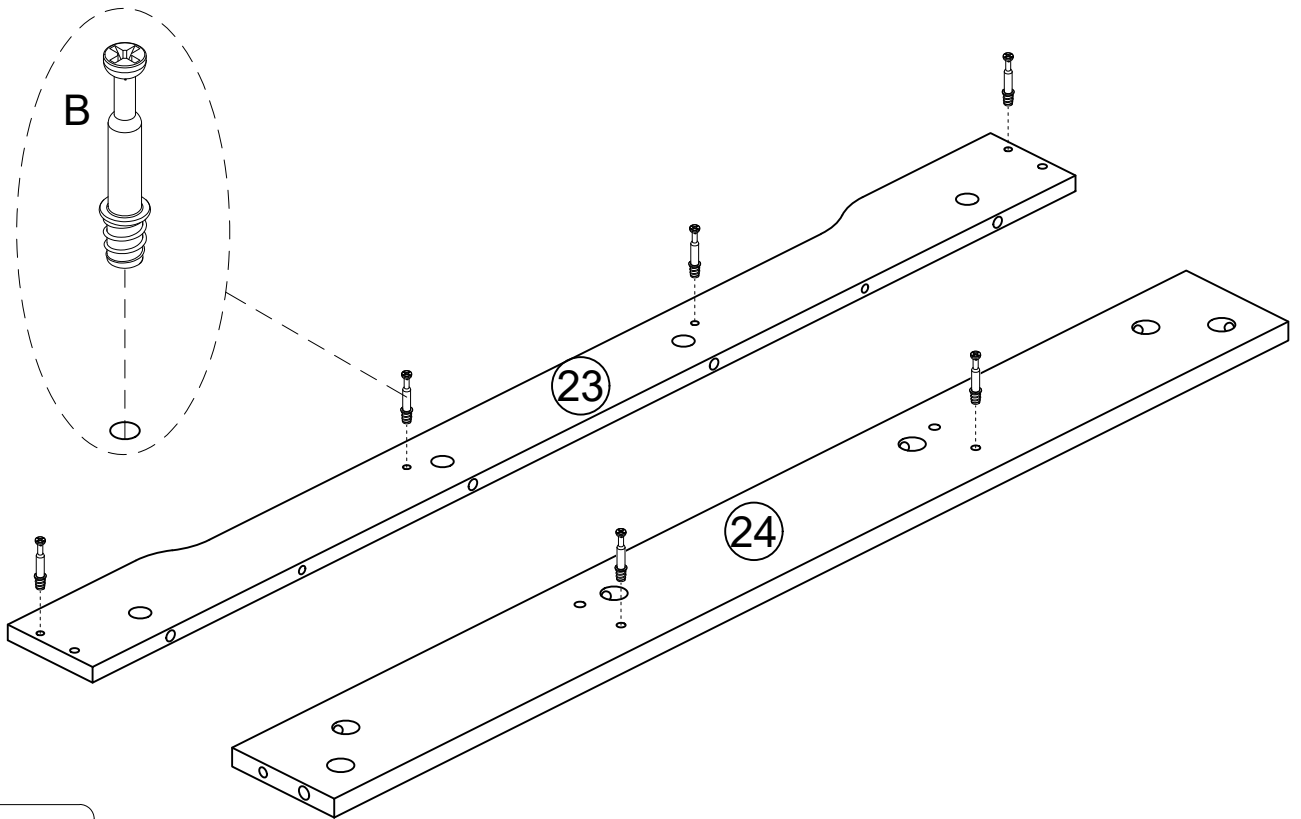

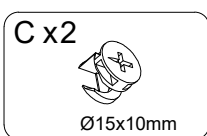
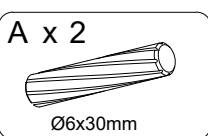
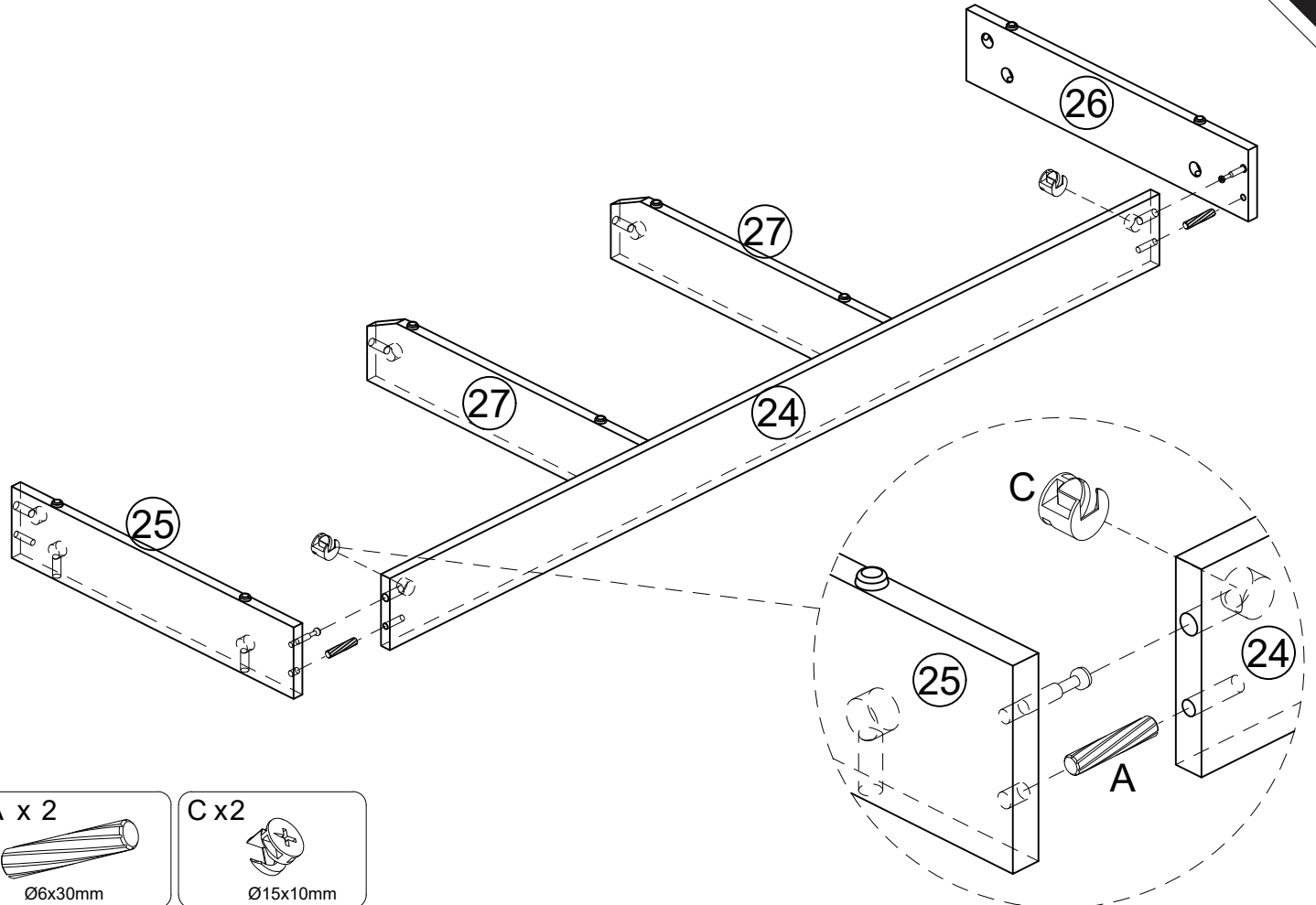
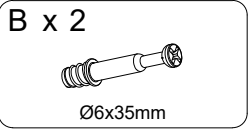
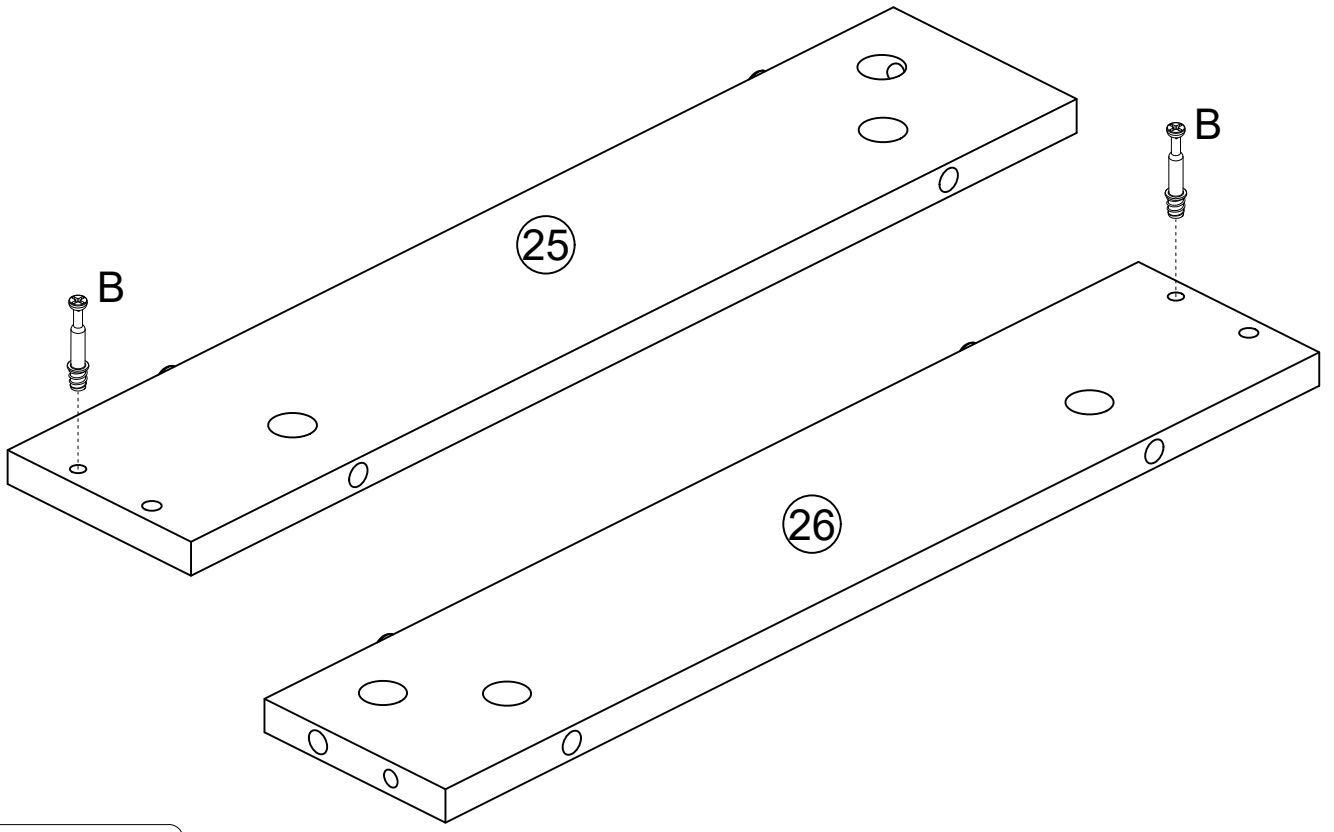

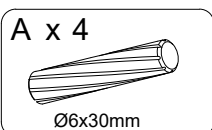
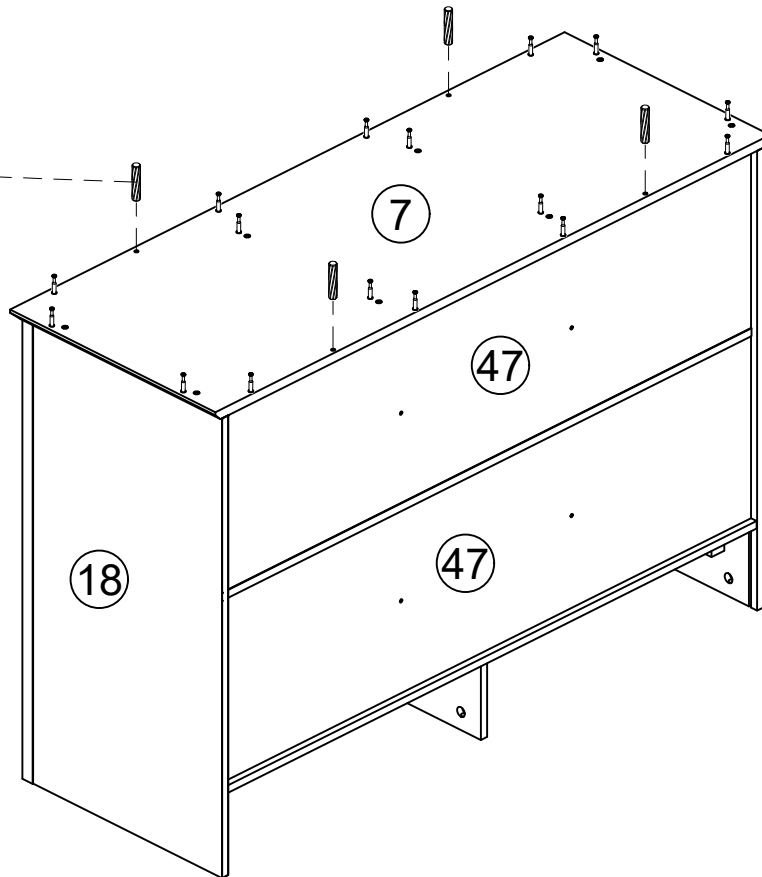
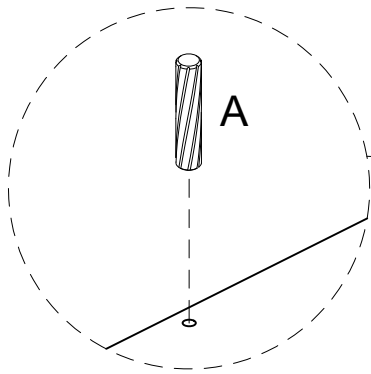
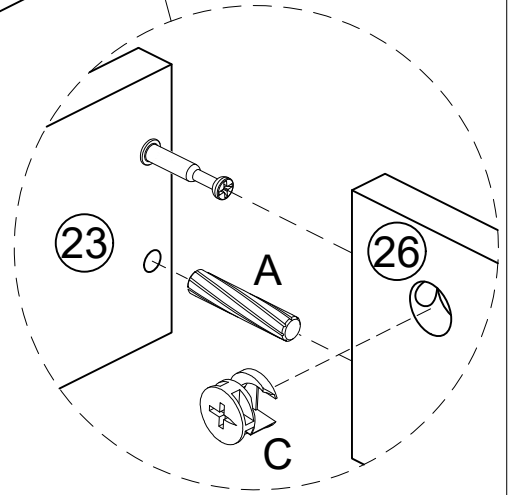
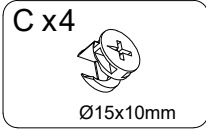
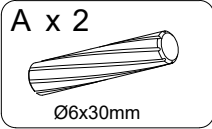
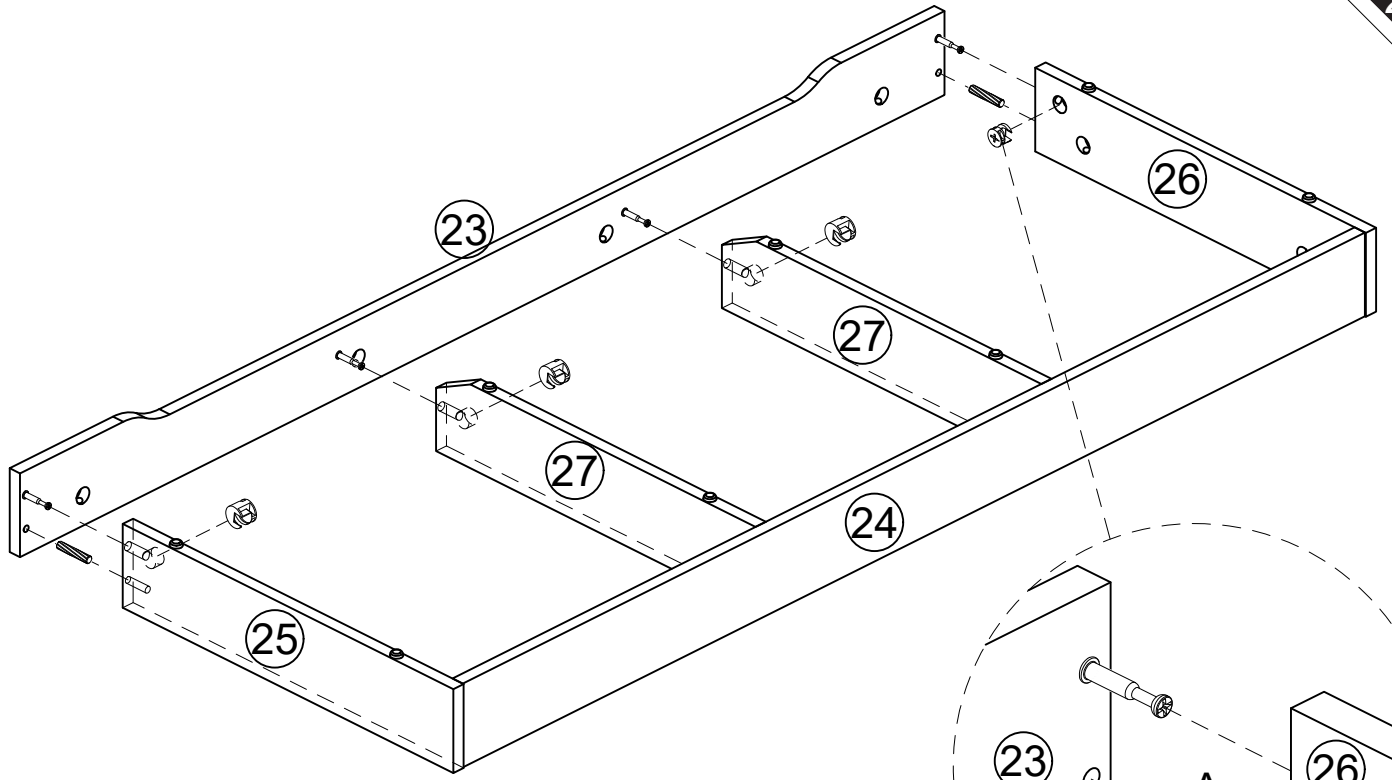

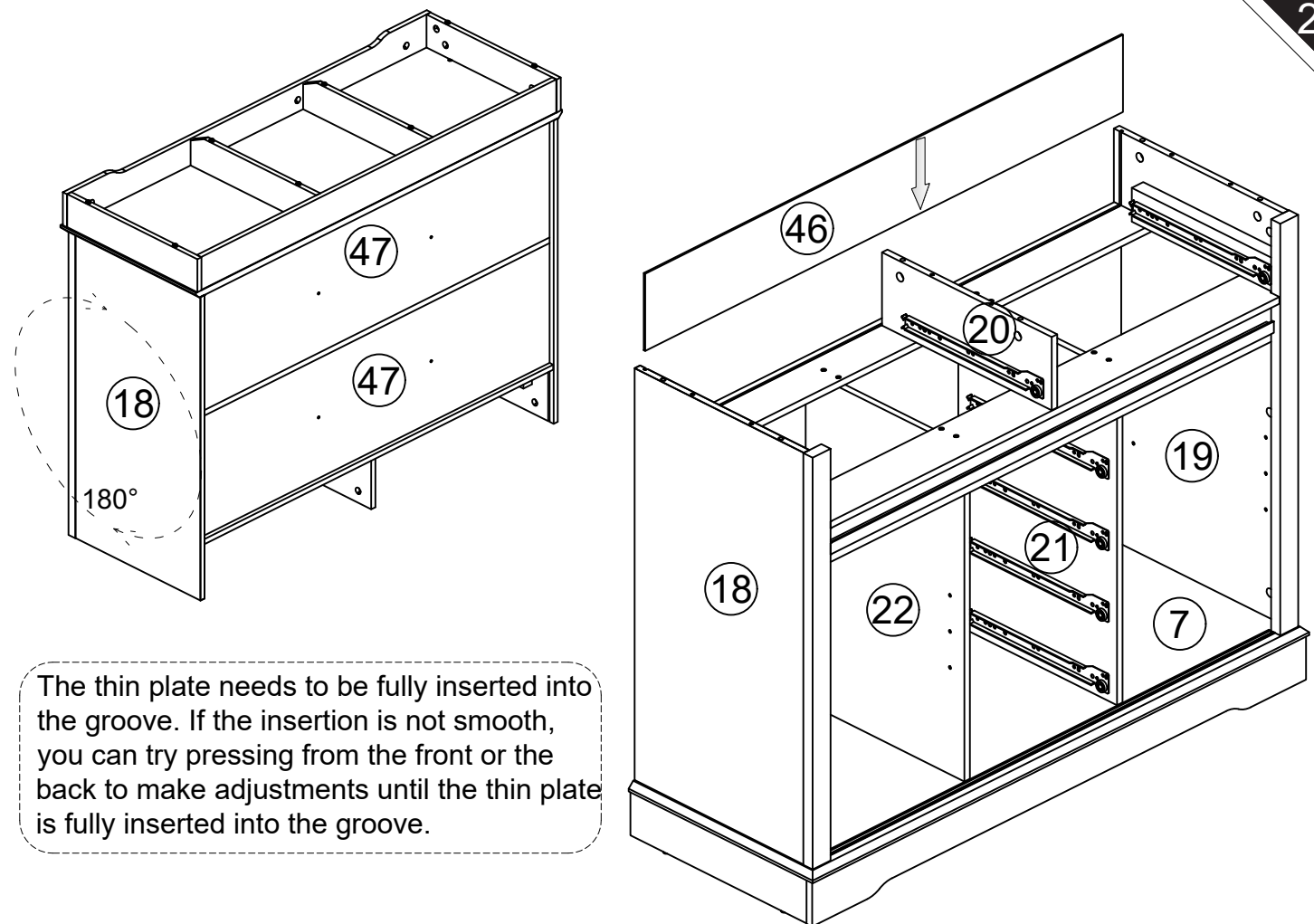
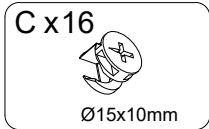
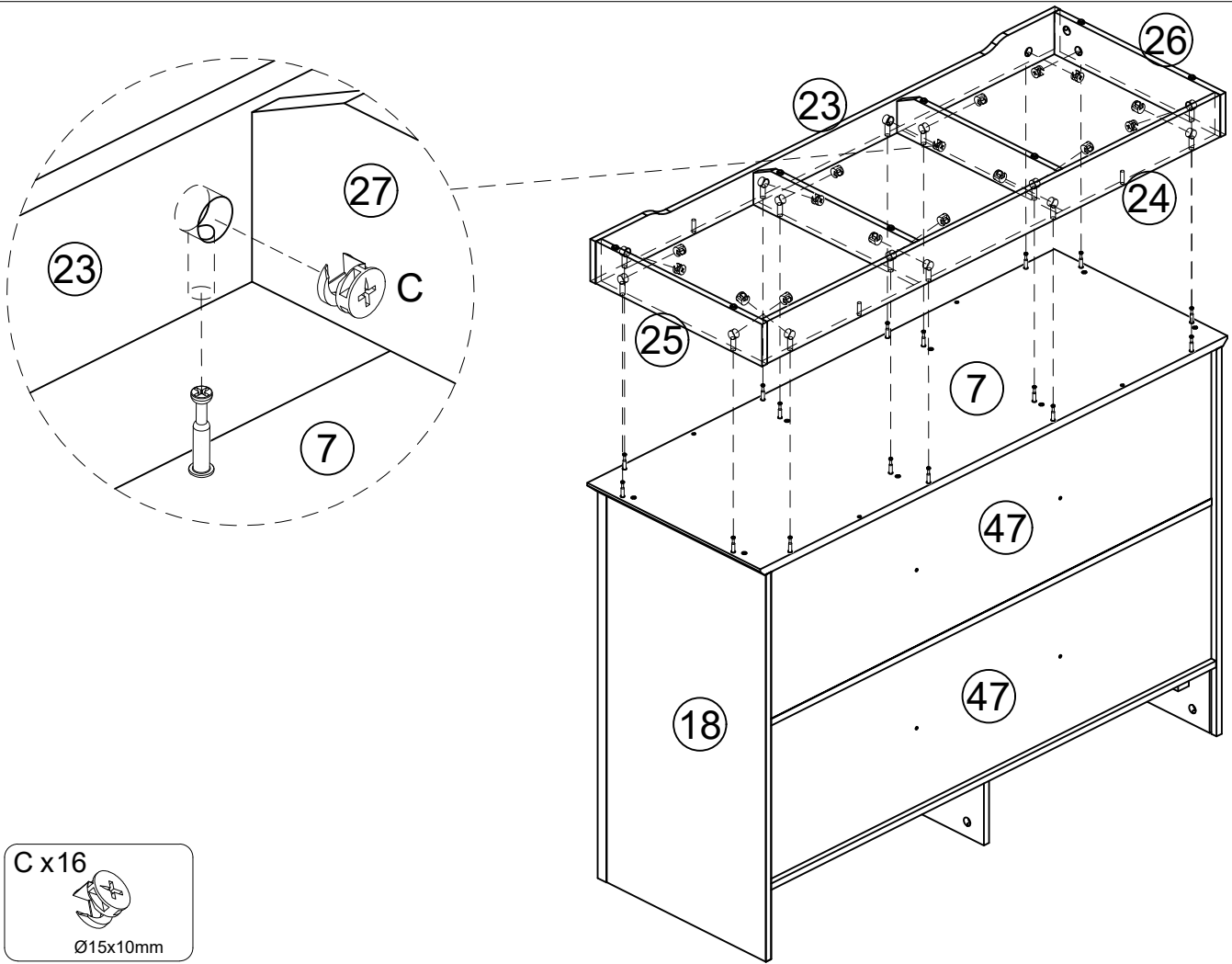

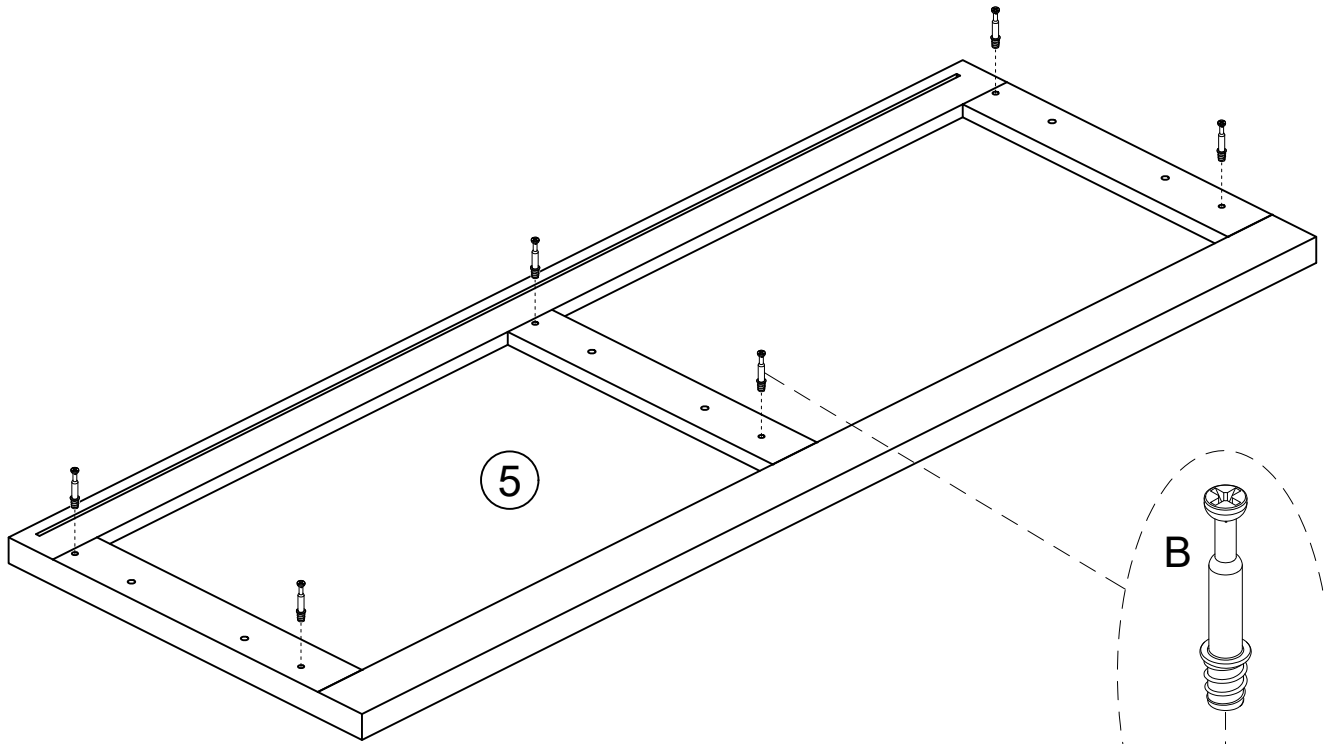

B

B x 6

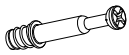

Ø6x35mm

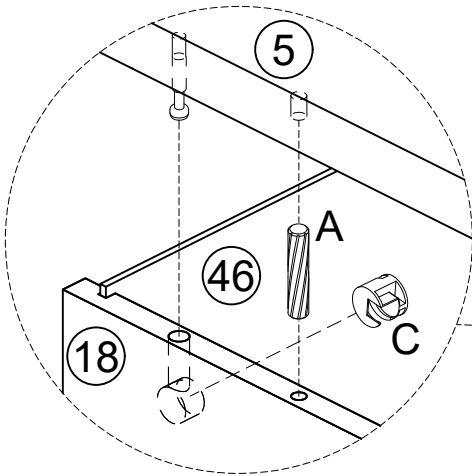

5

A

46

C

18

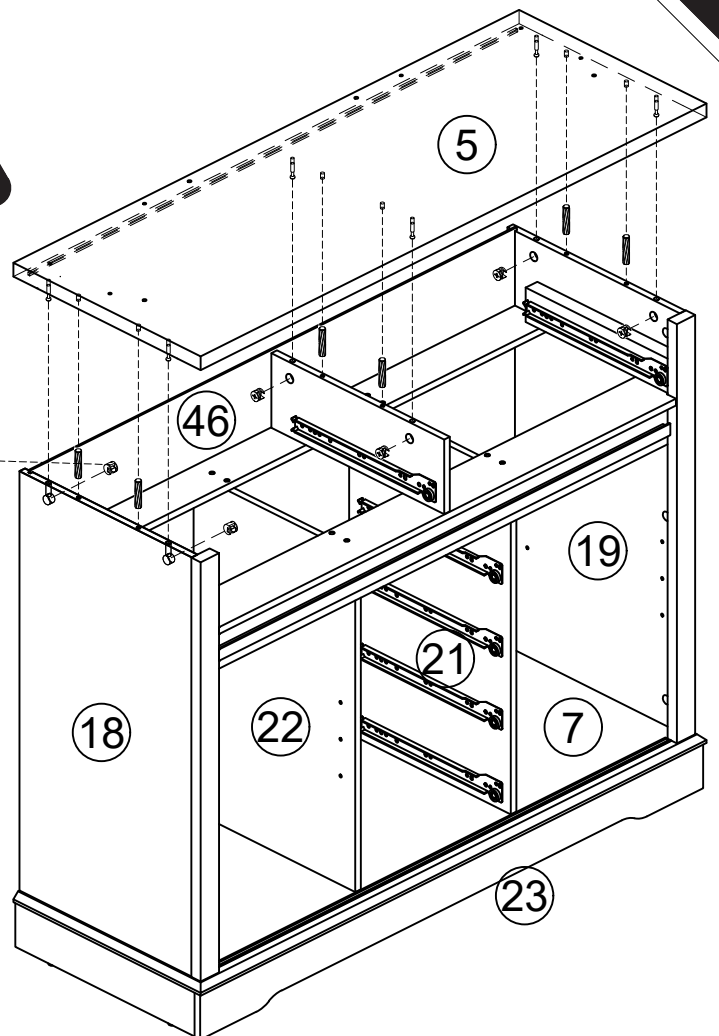

5

46

19

18

22

7

23

The thin plate needs to be fully inserted into the groove. If the insertion is not smooth, you can try pressing from the front or the back to make adjustments until the thin plate is fully inserted into the groove.

A x 6



Ø6x30mm

C x 6



Ø15x10mm

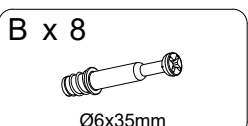
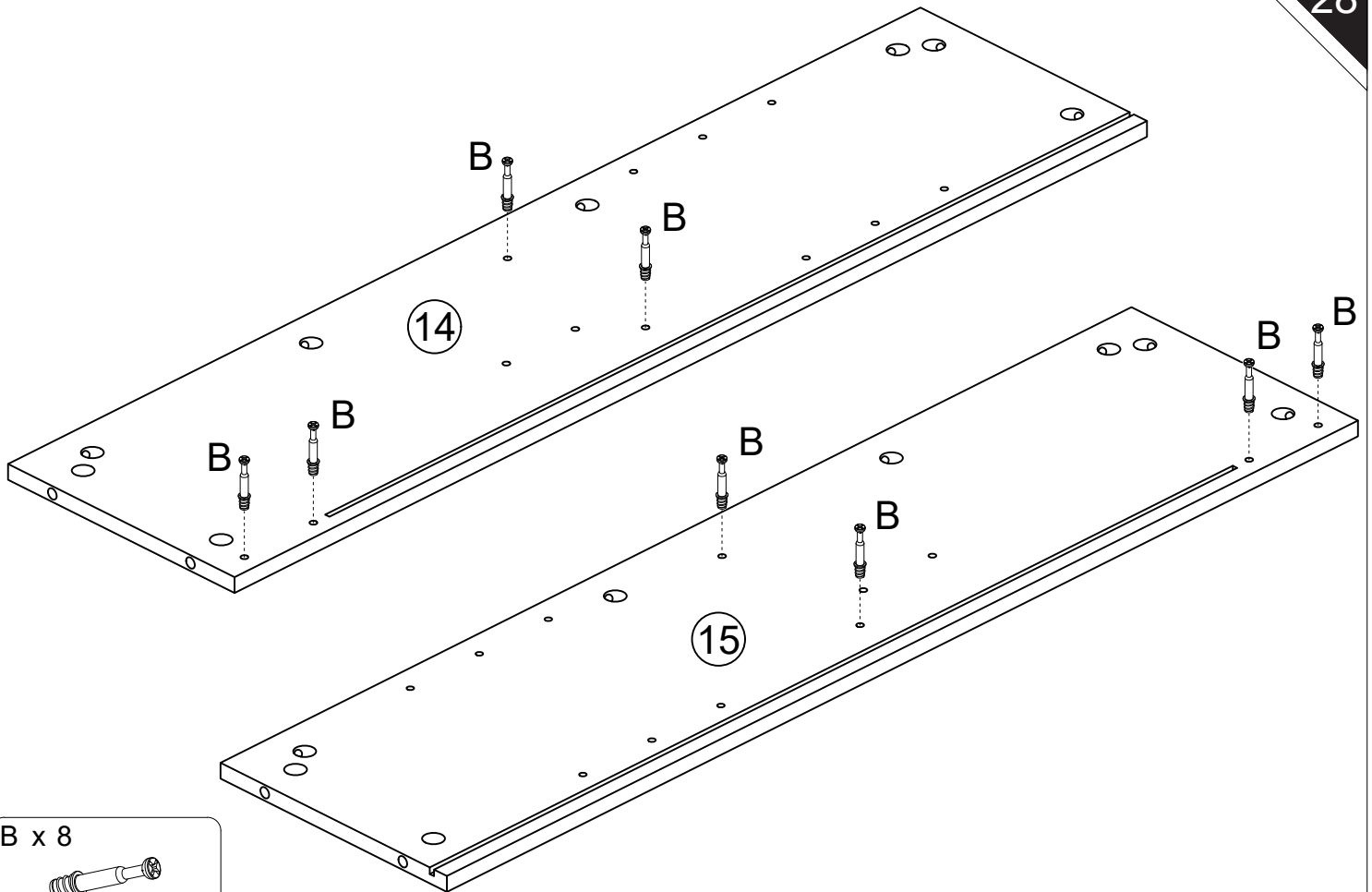
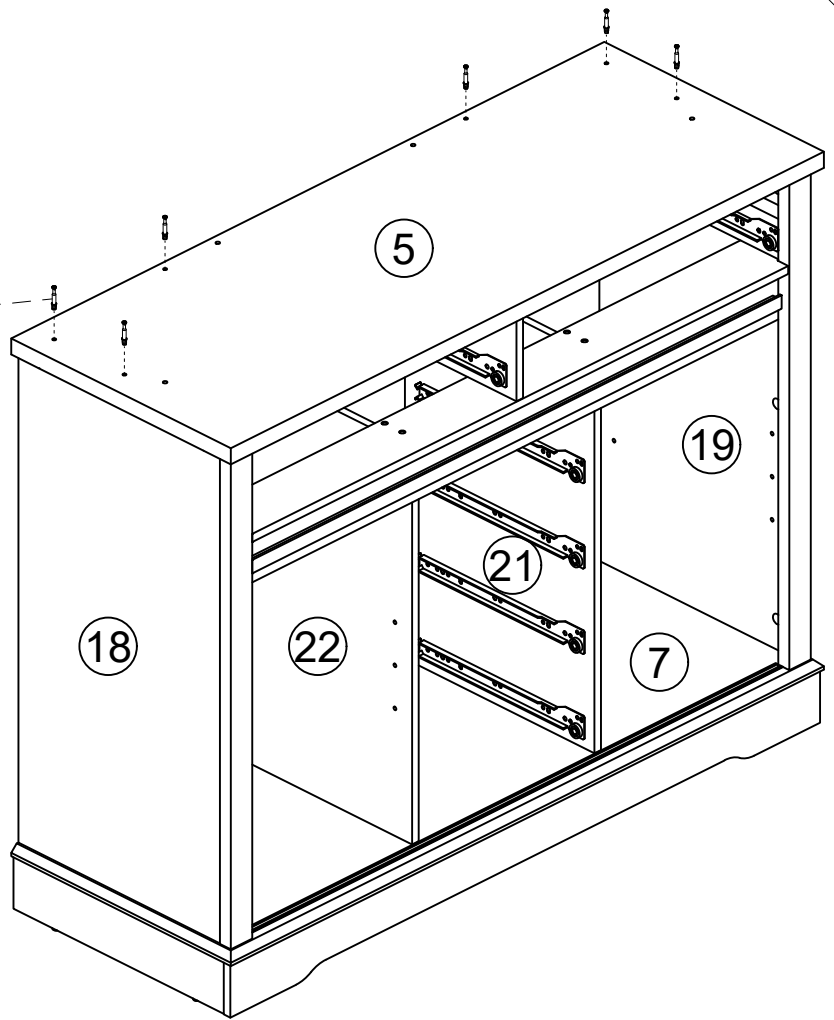
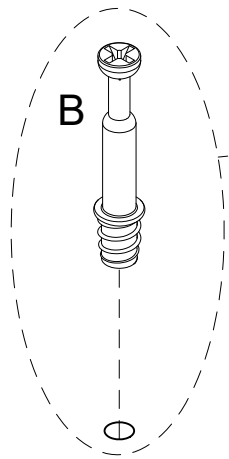

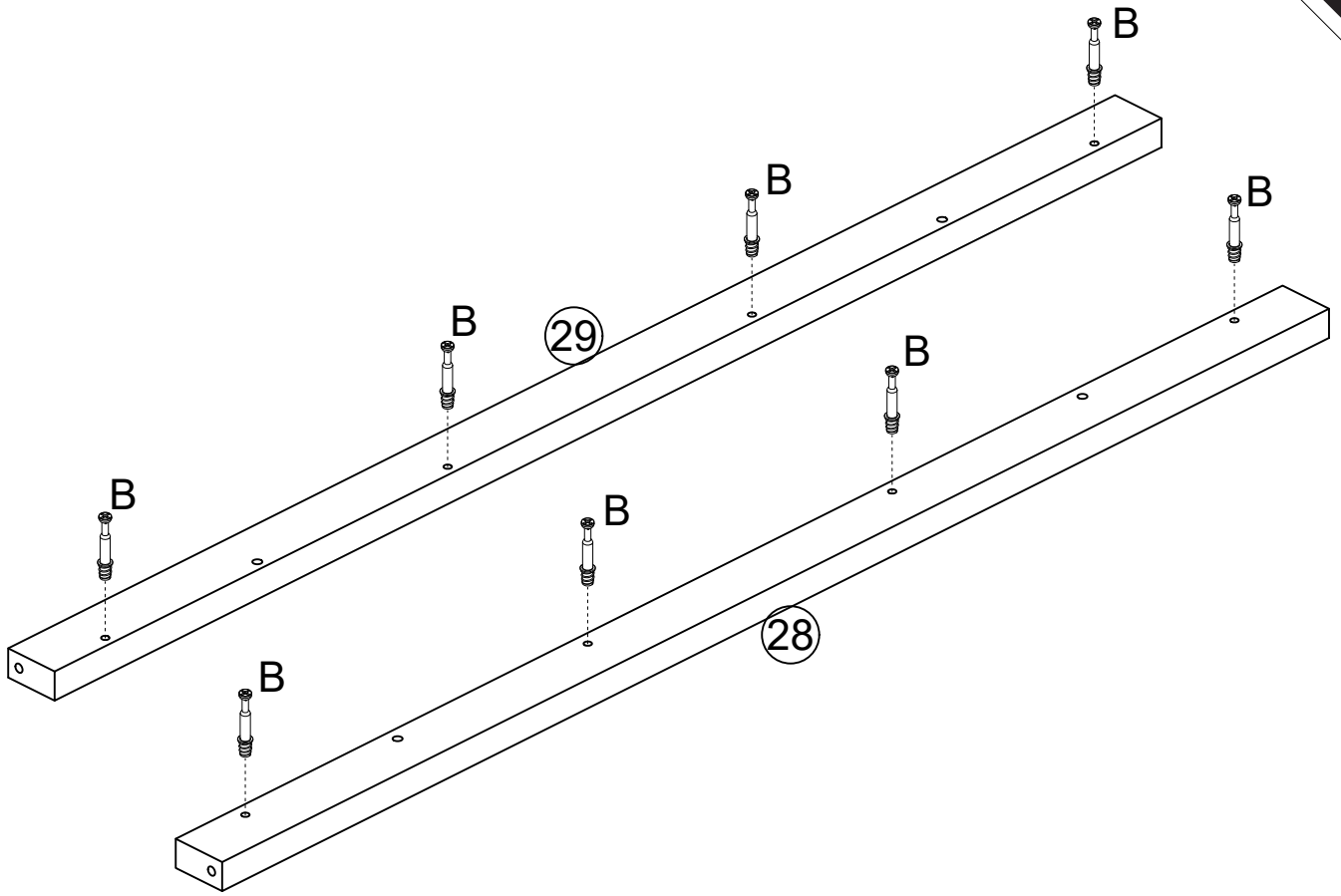

Pay attention to the positions of the four small holes on the back.

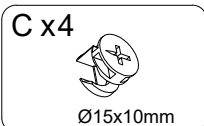
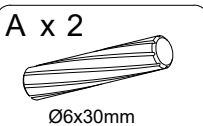
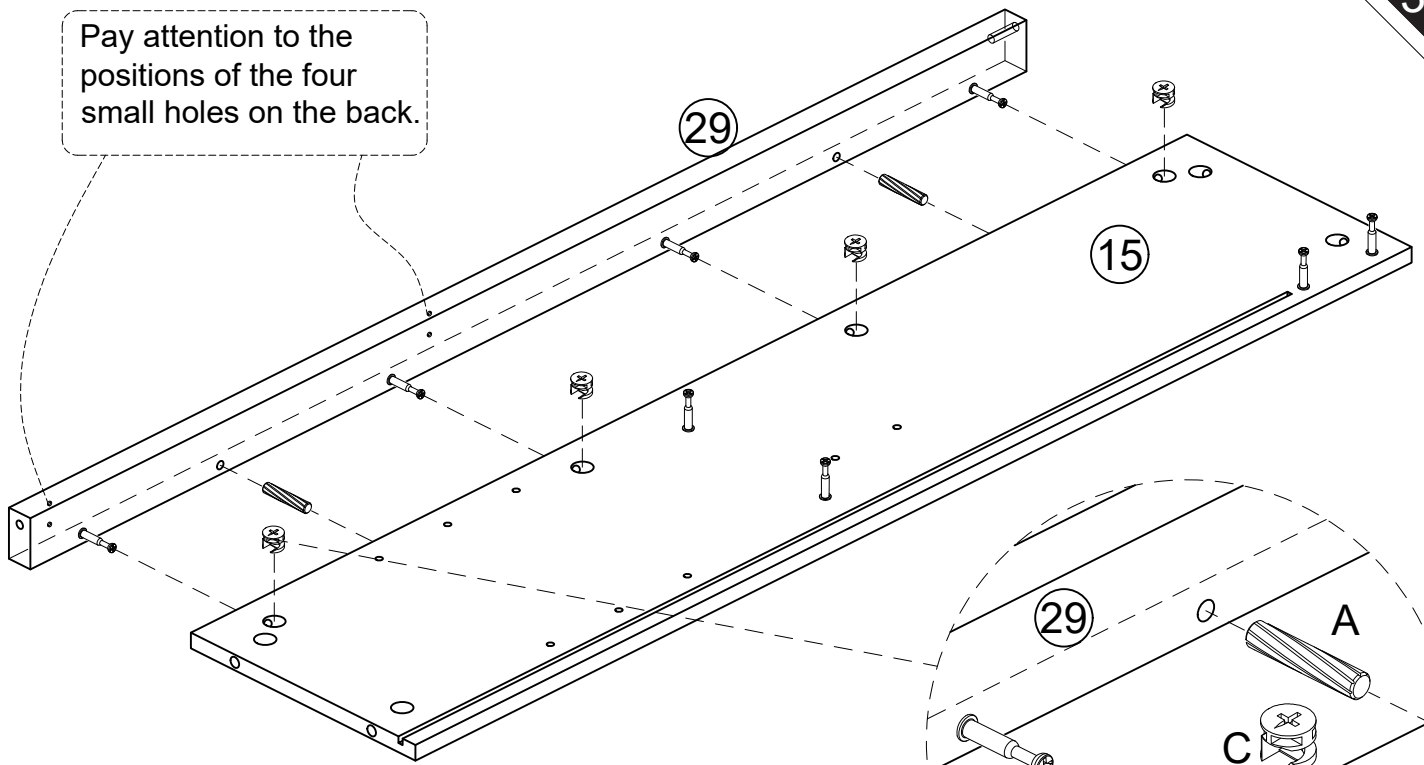

Pay attention to the positions of the four small holes on the back.

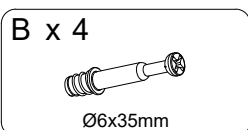
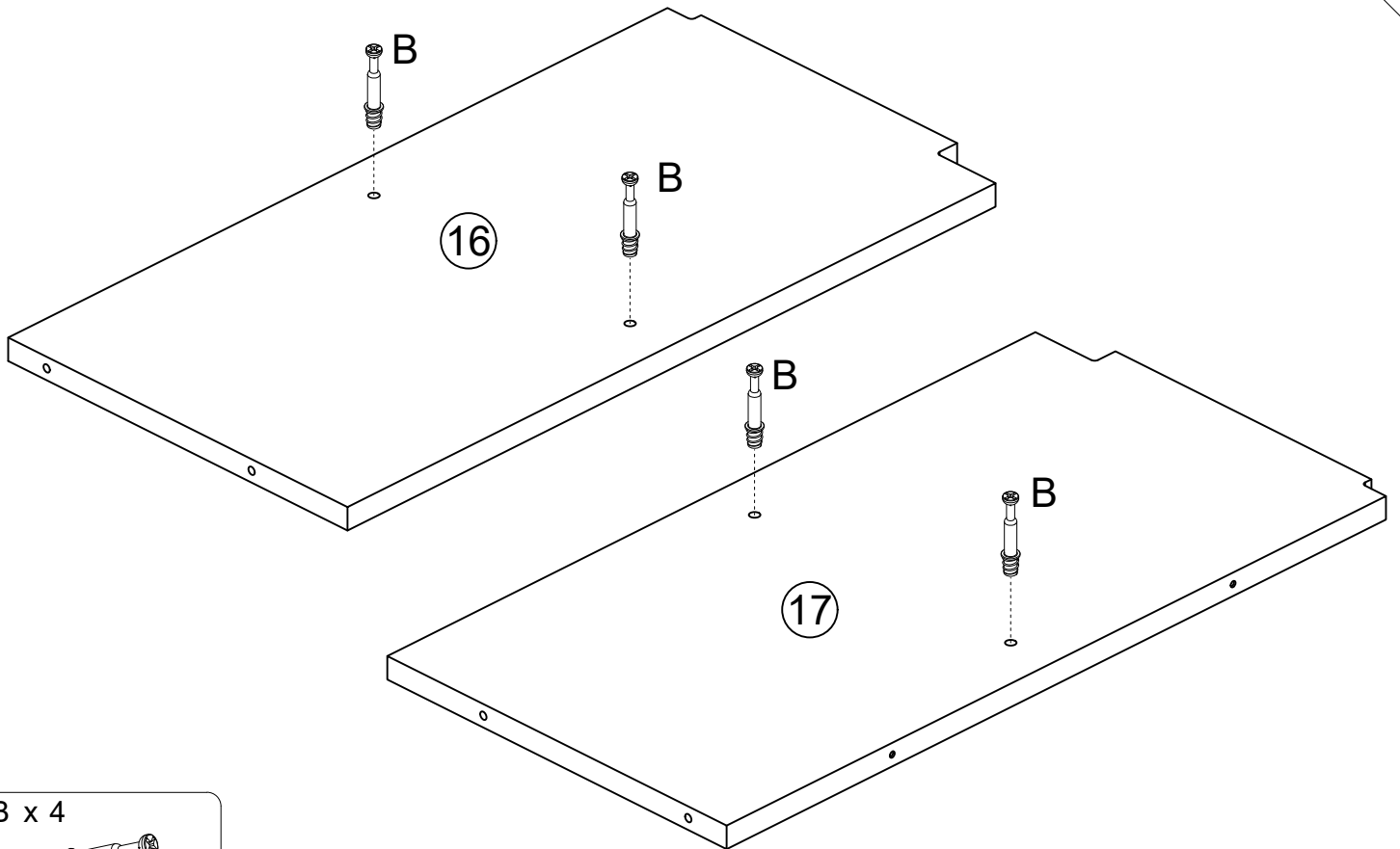
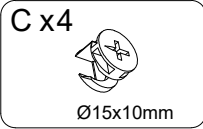
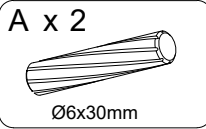
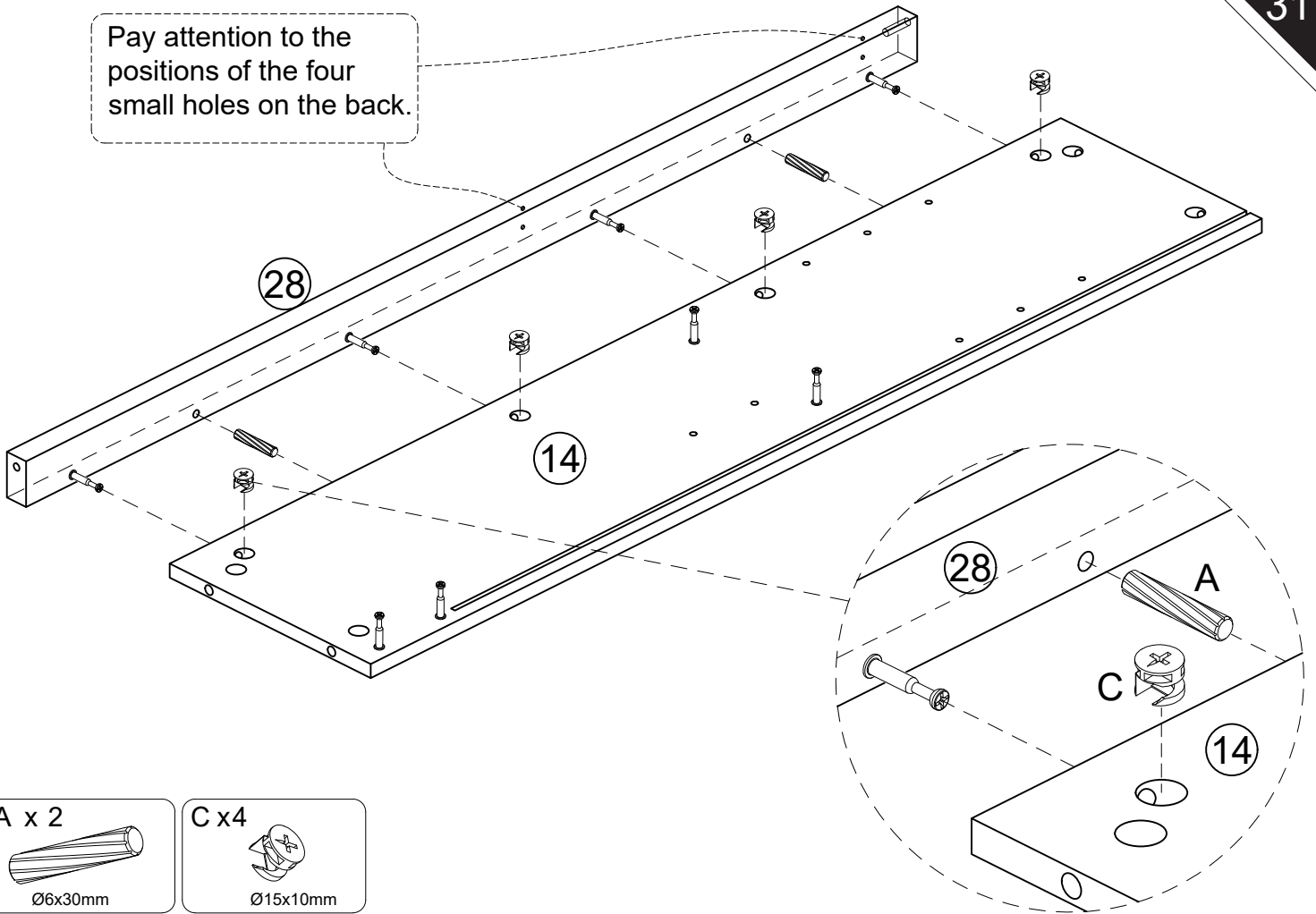

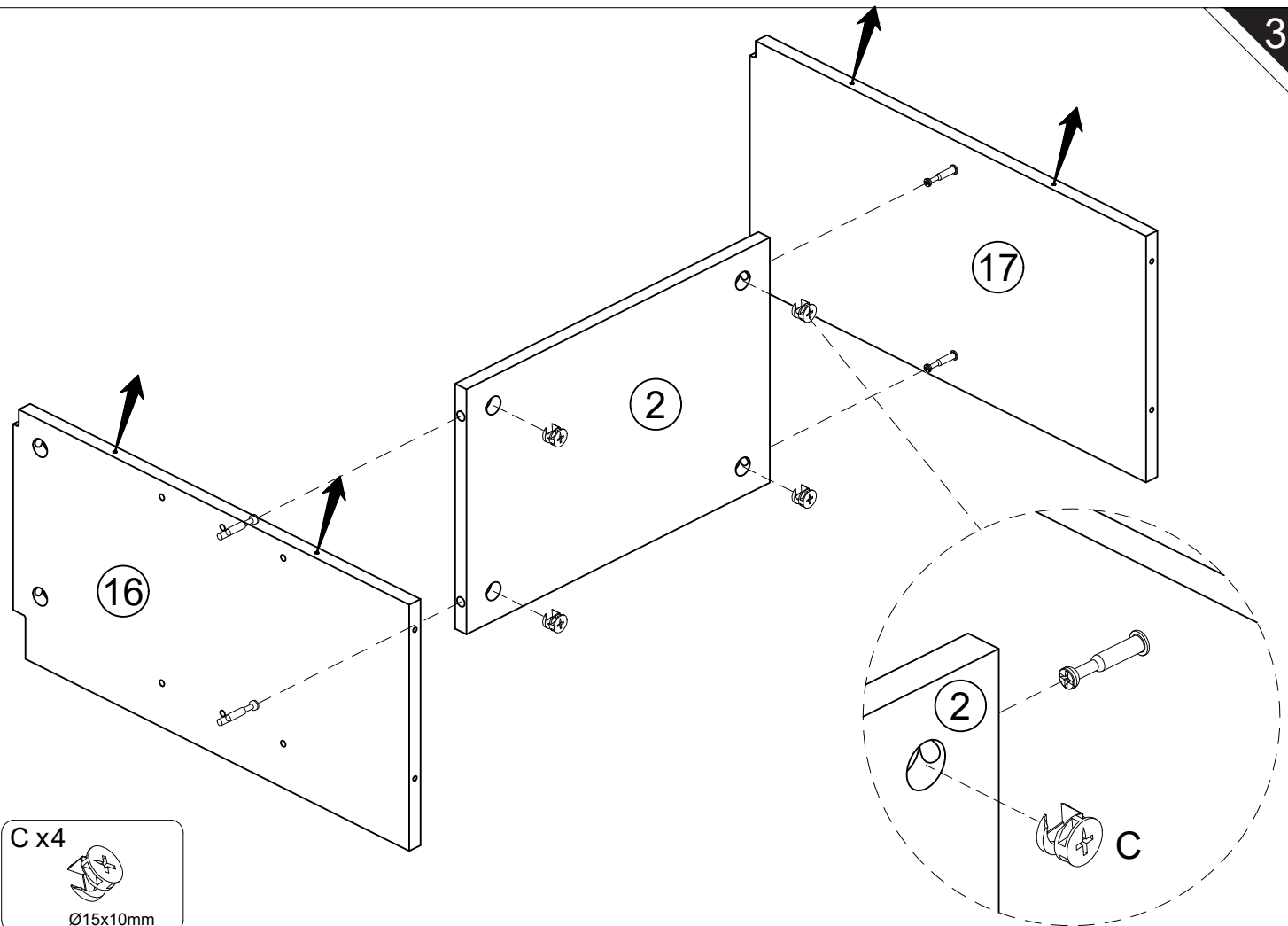

C x 4  
Ø15x10mm

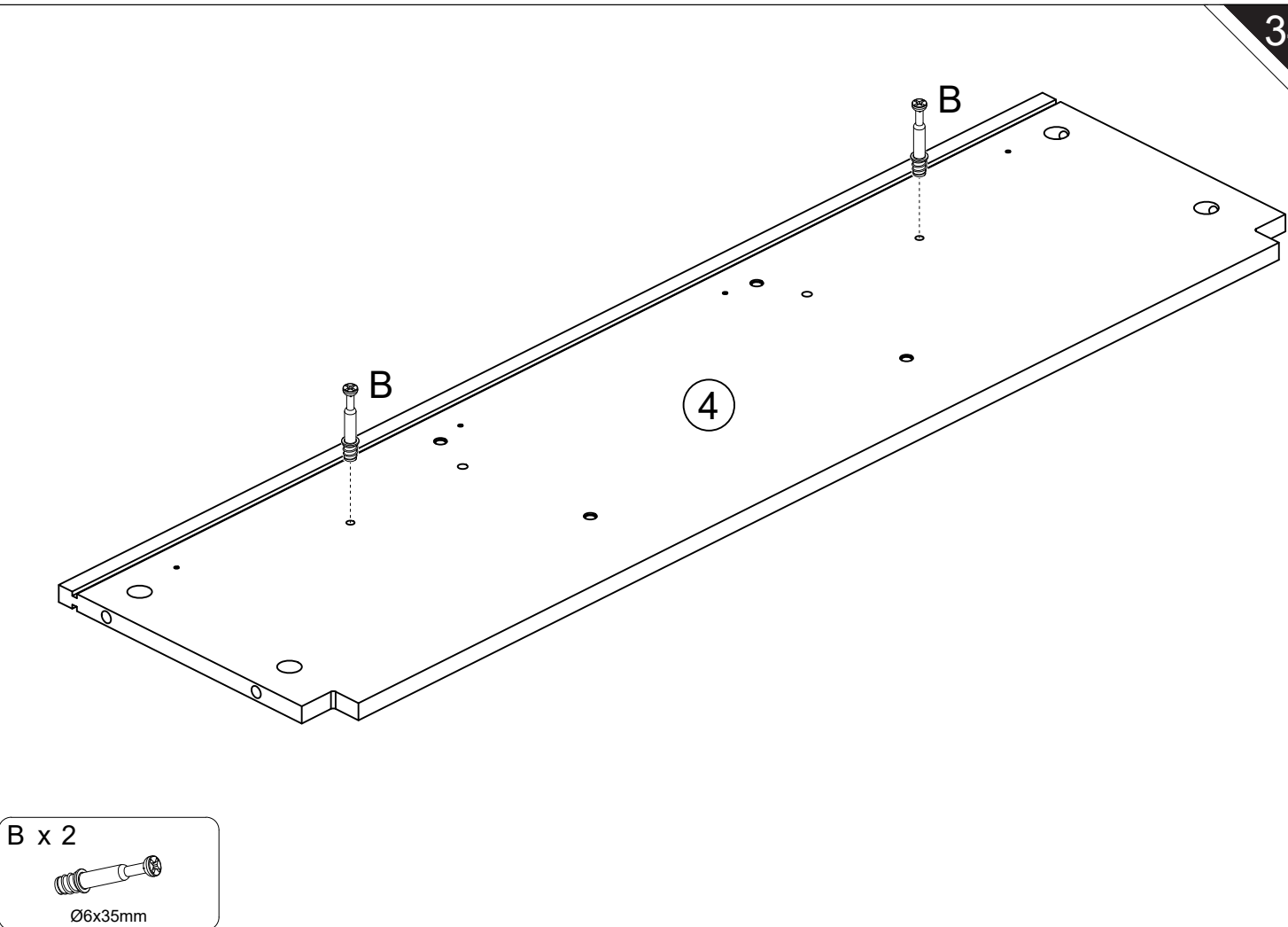

B x 2  
Ø6x35mm

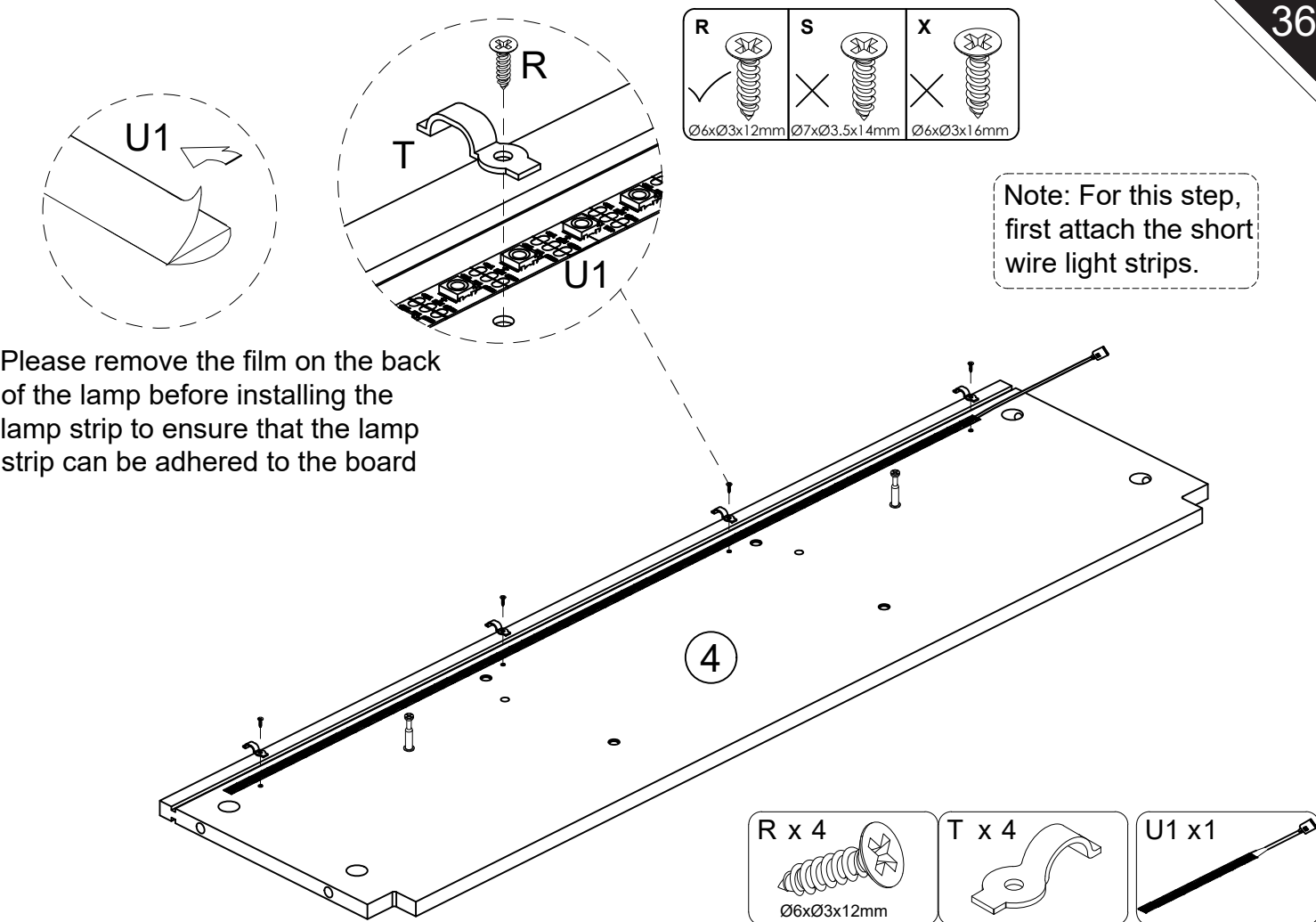
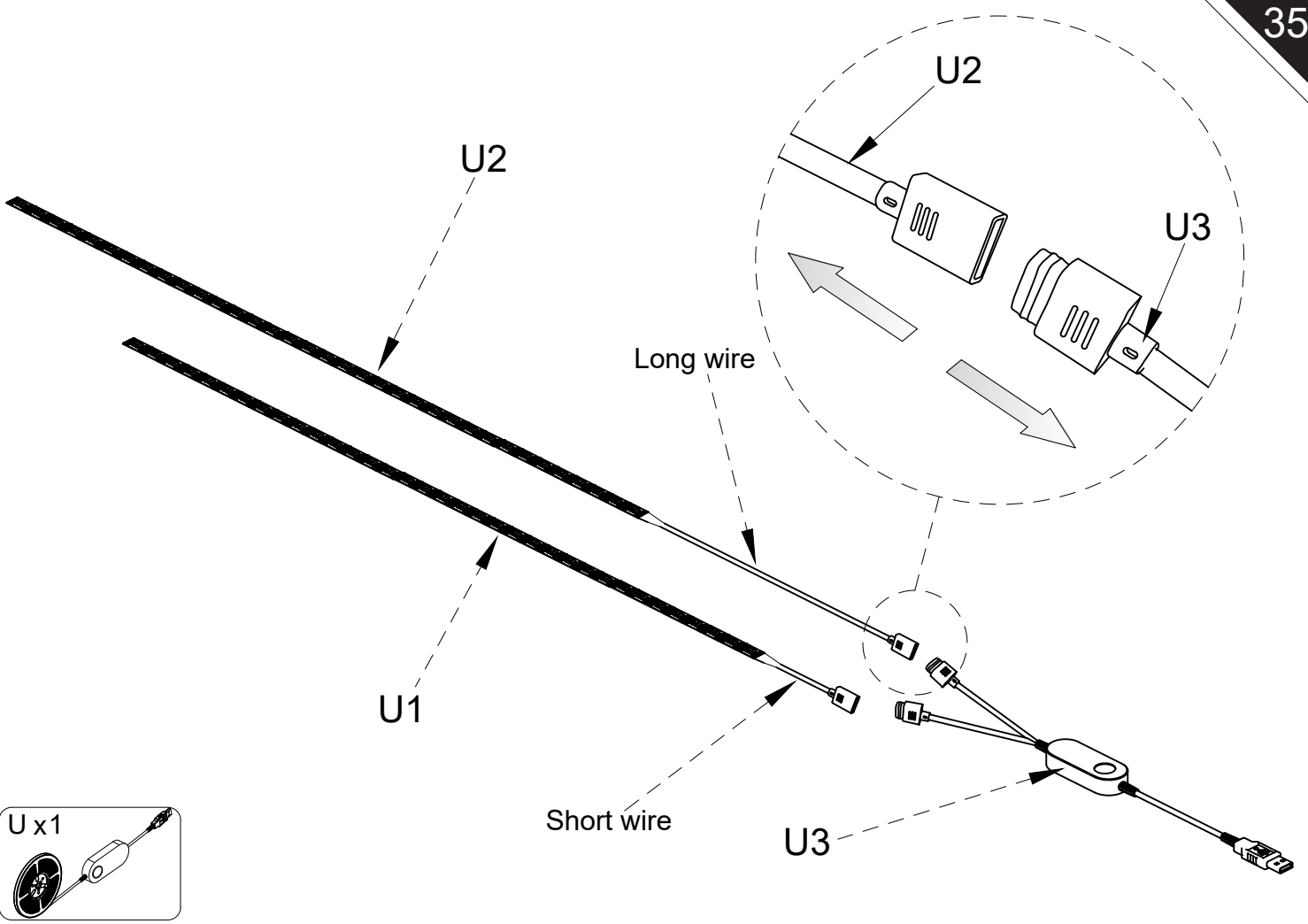

Please remove the film on the back of the lamp before installing the lamp strip to ensure that the lamp strip can be adhered to the board

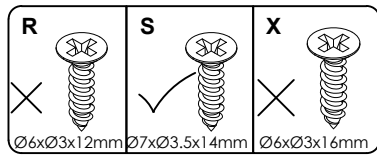
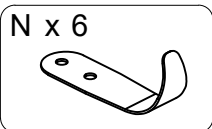
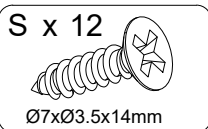
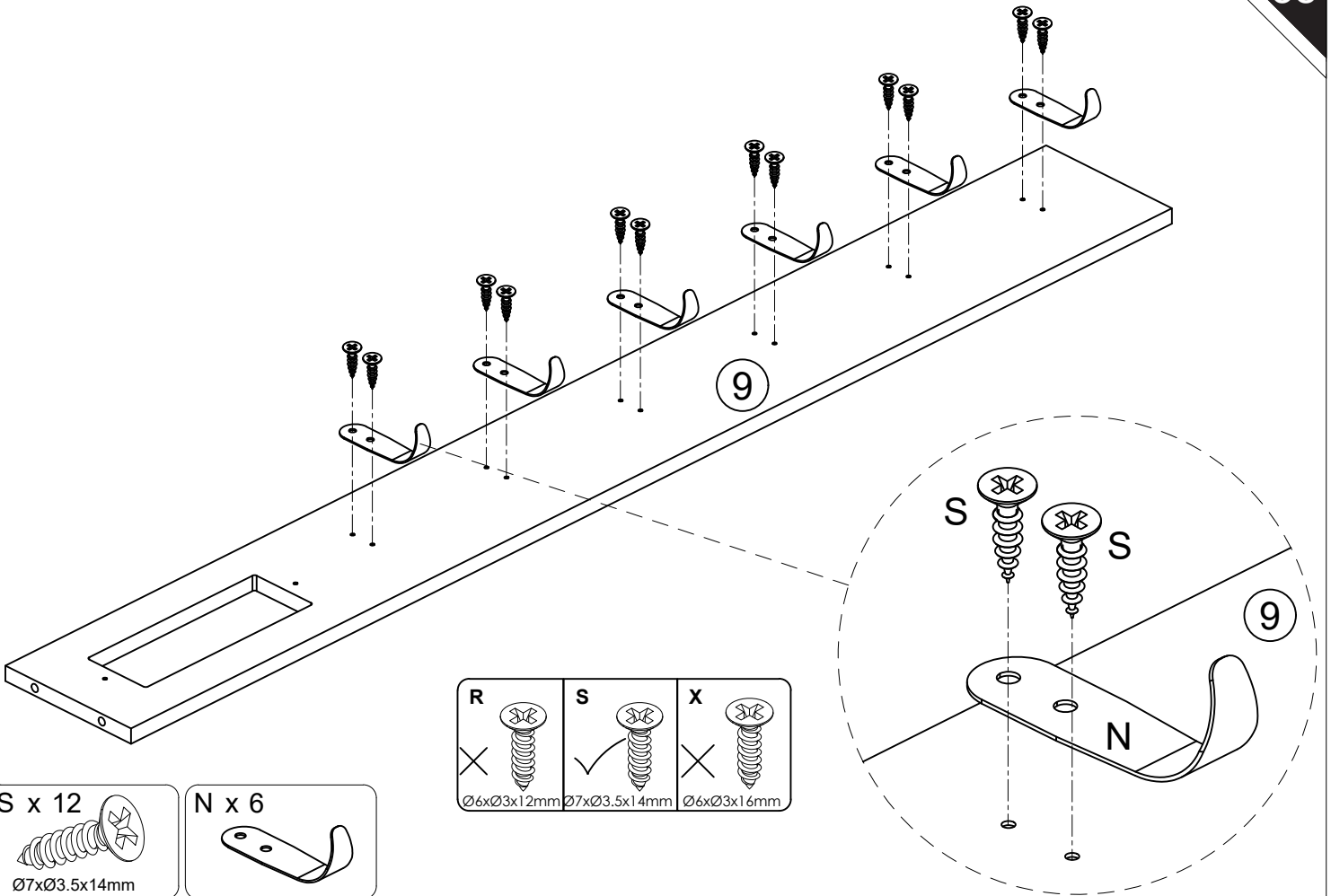
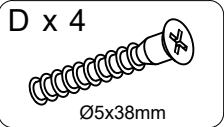
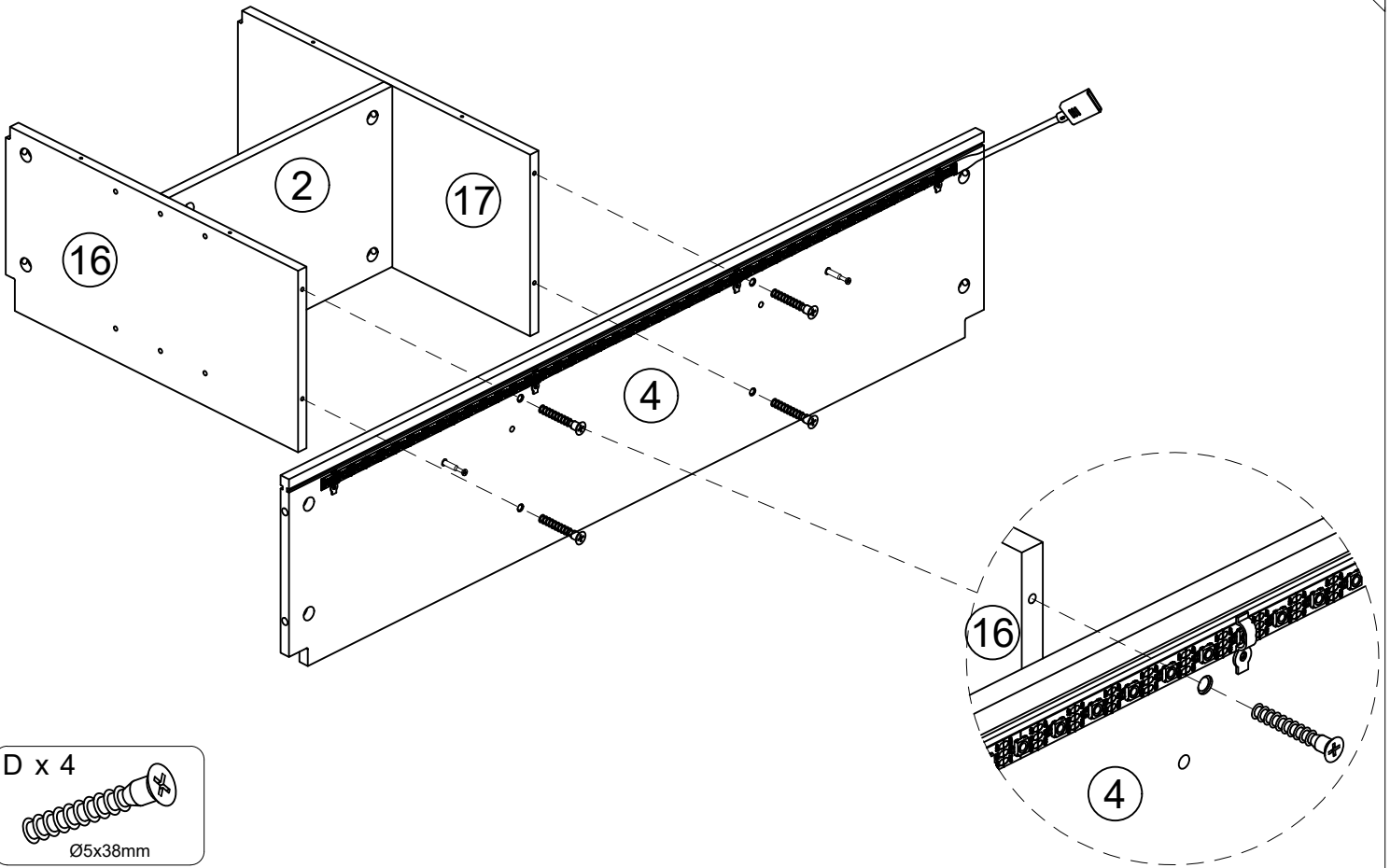

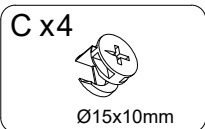
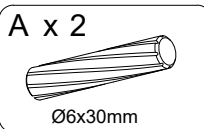
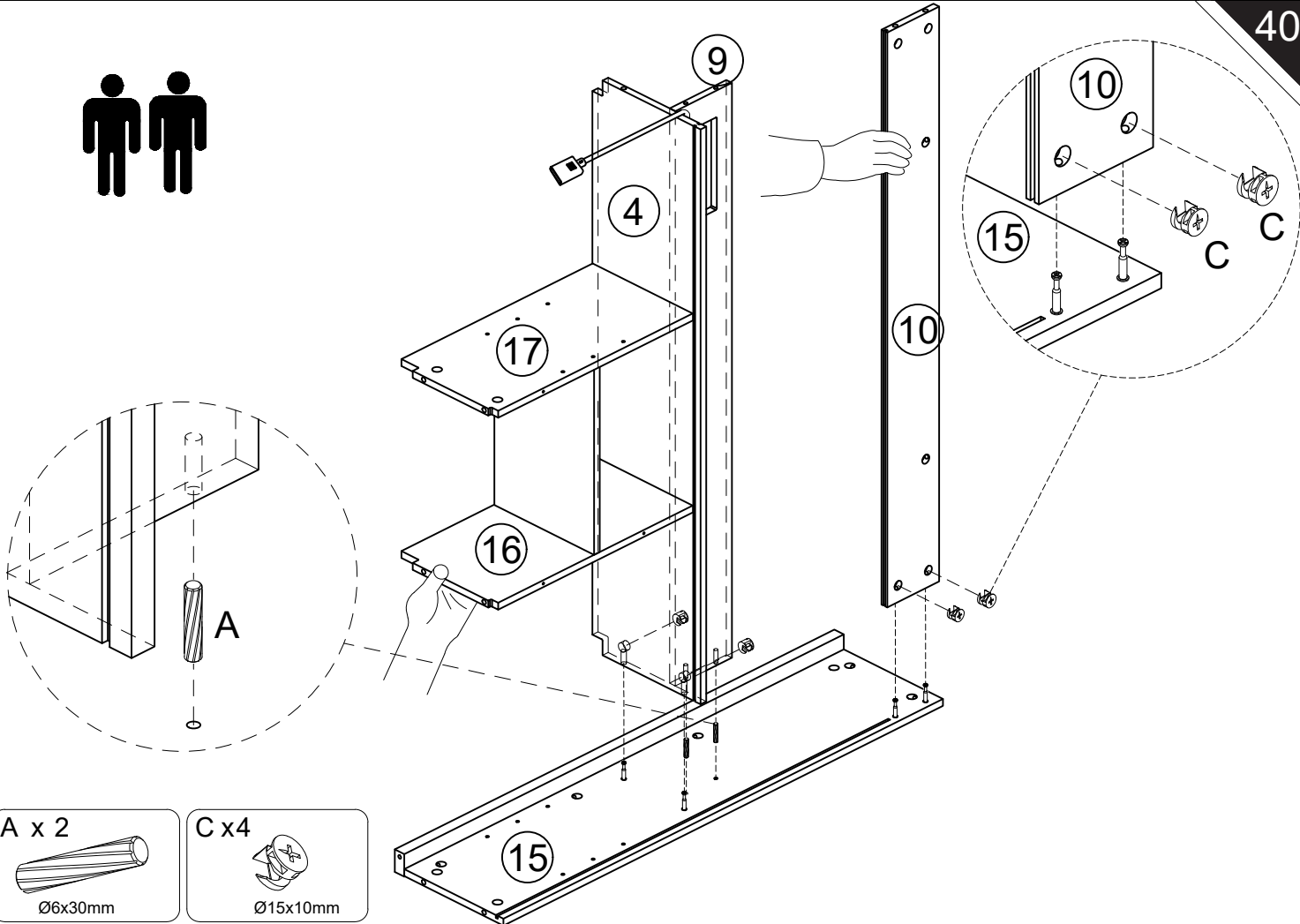
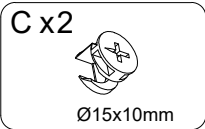
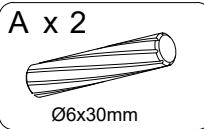
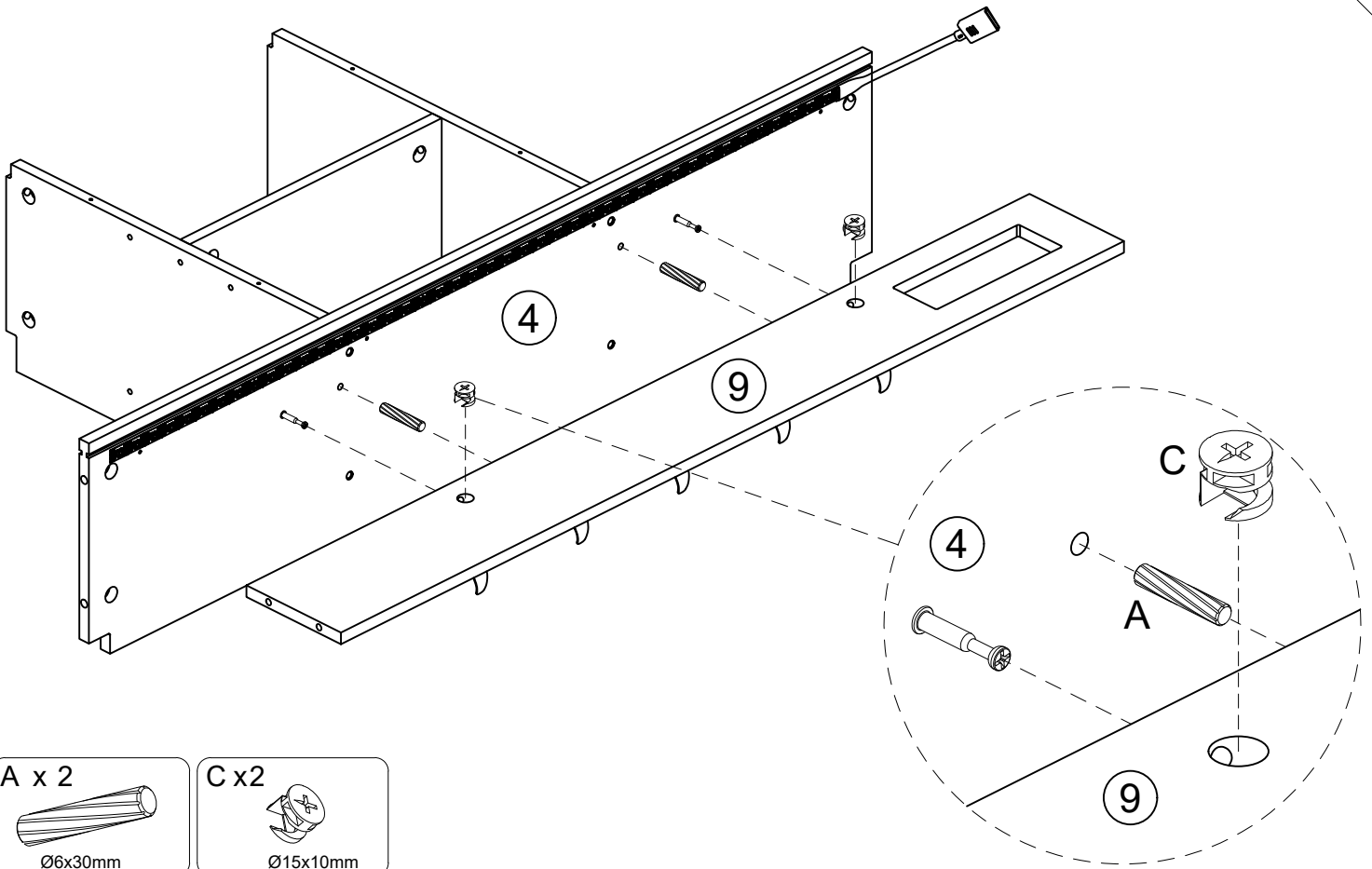

The thin plate needs to be fully inserted into the groove. If the insertion is not smooth, you can try pressing from the front or the back to make adjustments until the thin plate is fully inserted into the groove.

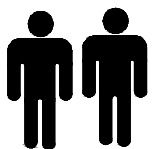
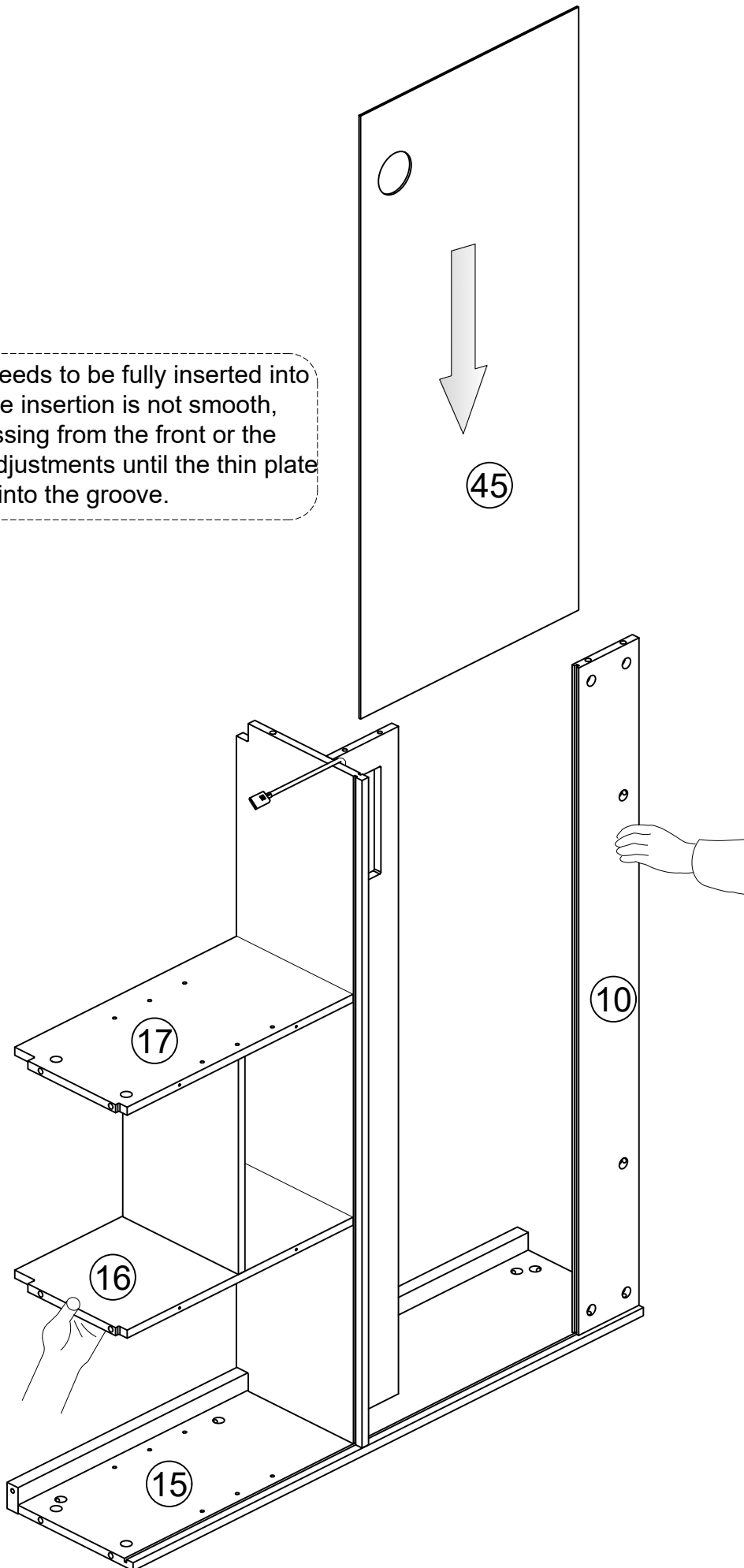

The thin plate needs to be fully inserted into the groove. If the insertion is not smooth, you can try pressing from the front or the back to make adjustments until the thin plate is fully inserted into the groove.

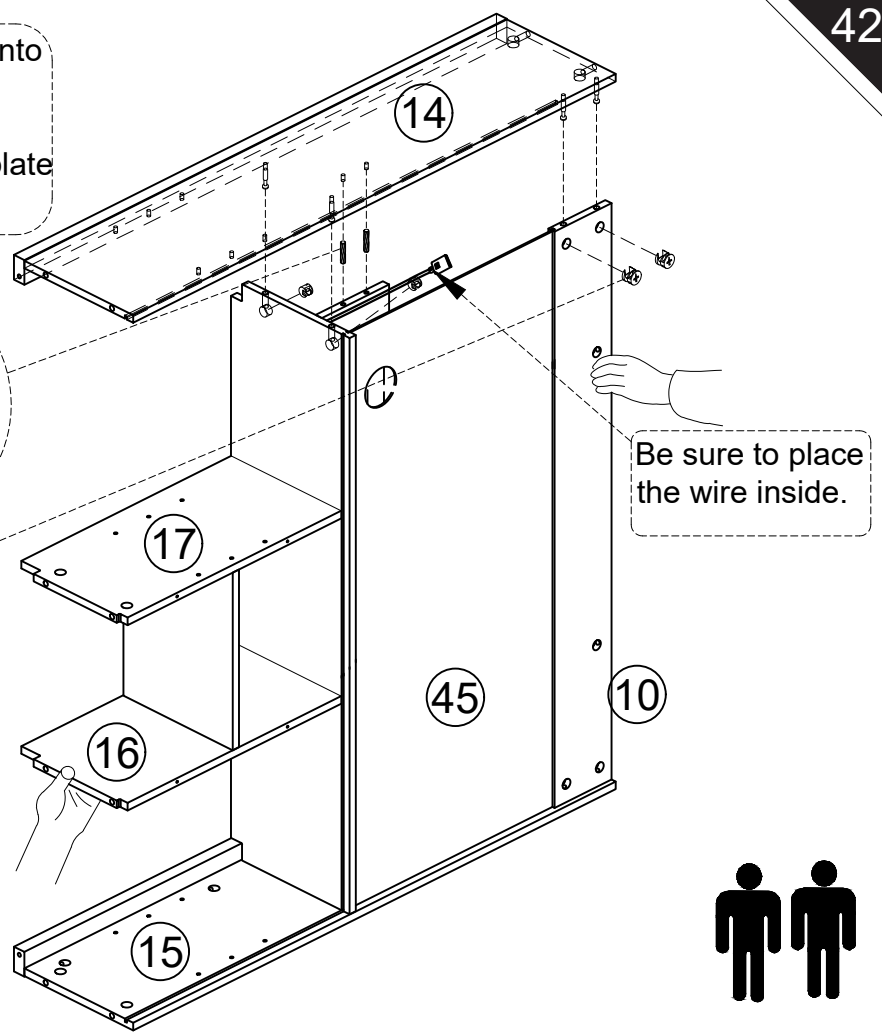
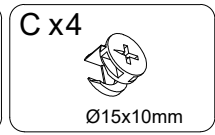
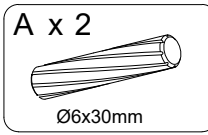
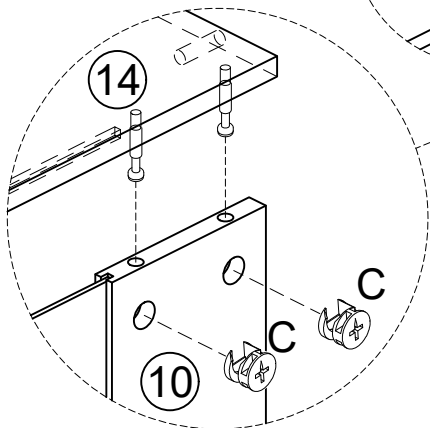
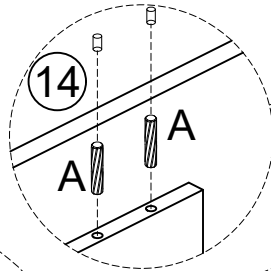

Be sure to place the wire inside.

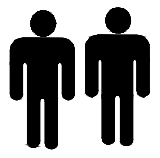

Note that the length of component #49 is 992mm.

The thin plate needs to be fully inserted into the groove. If the insertion is not smooth, you can try pressing from the front or the back to make adjustments until the thin plate is fully inserted into the groove.

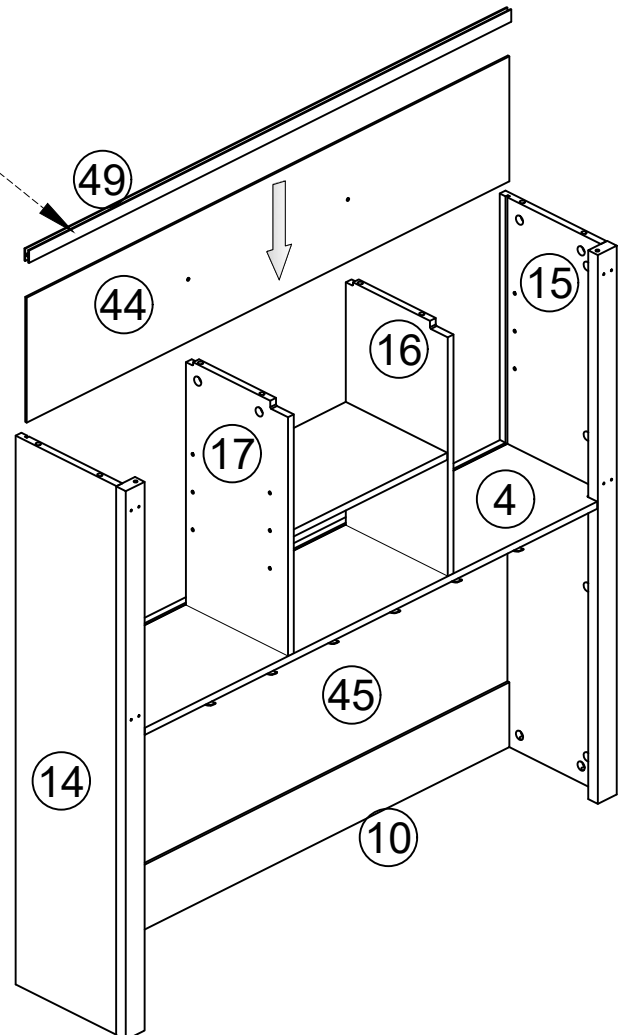
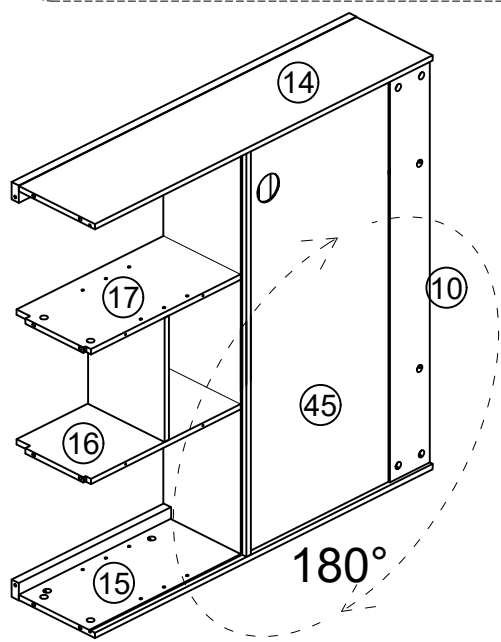

The thin plate needs to be fully inserted into the groove. If the insertion is not smooth, you can try pressing from the front or the back to make adjustments until the thin plate is fully inserted into the groove.

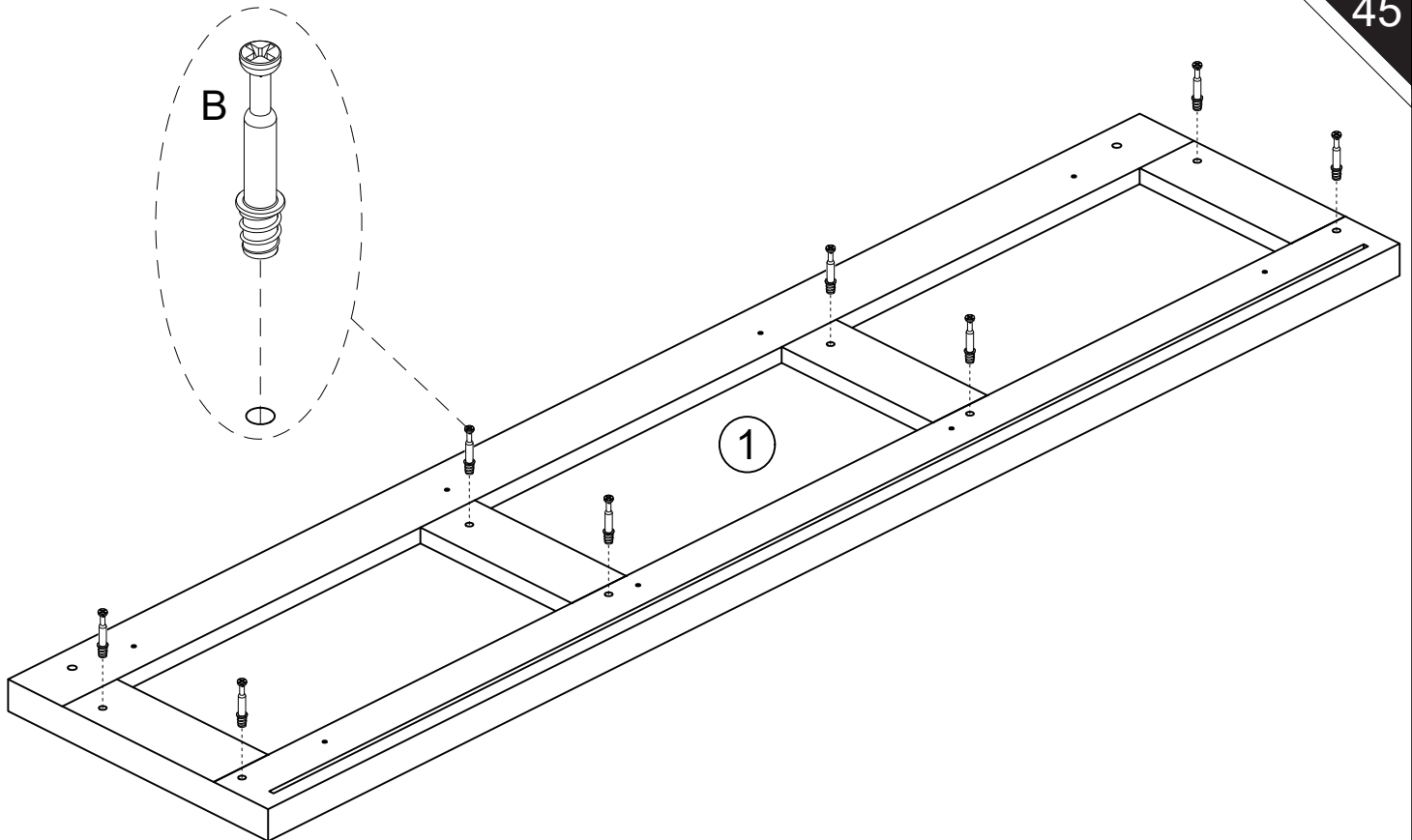
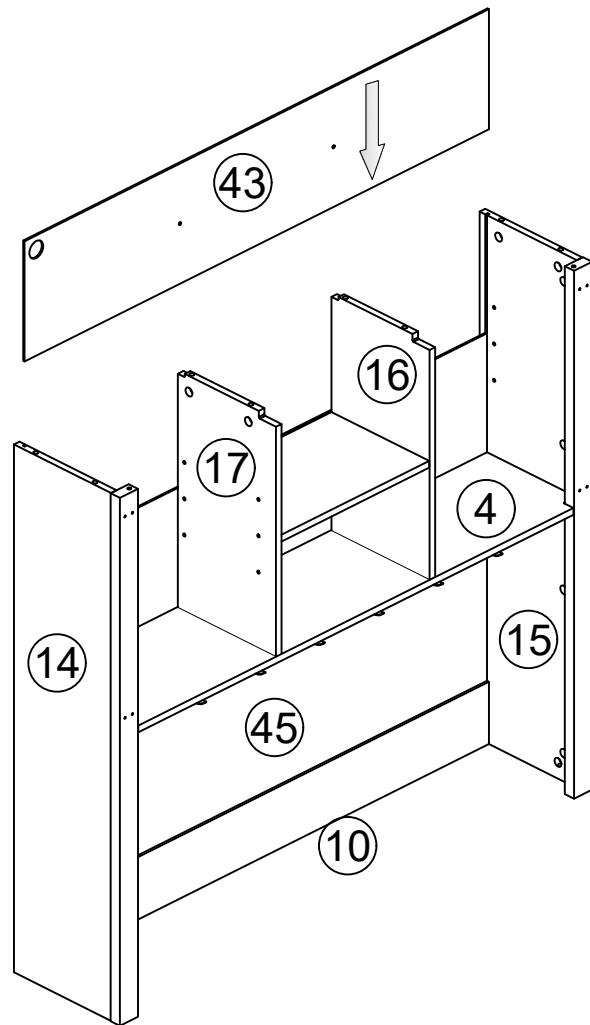

B x 8

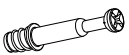

Ø6x35mm

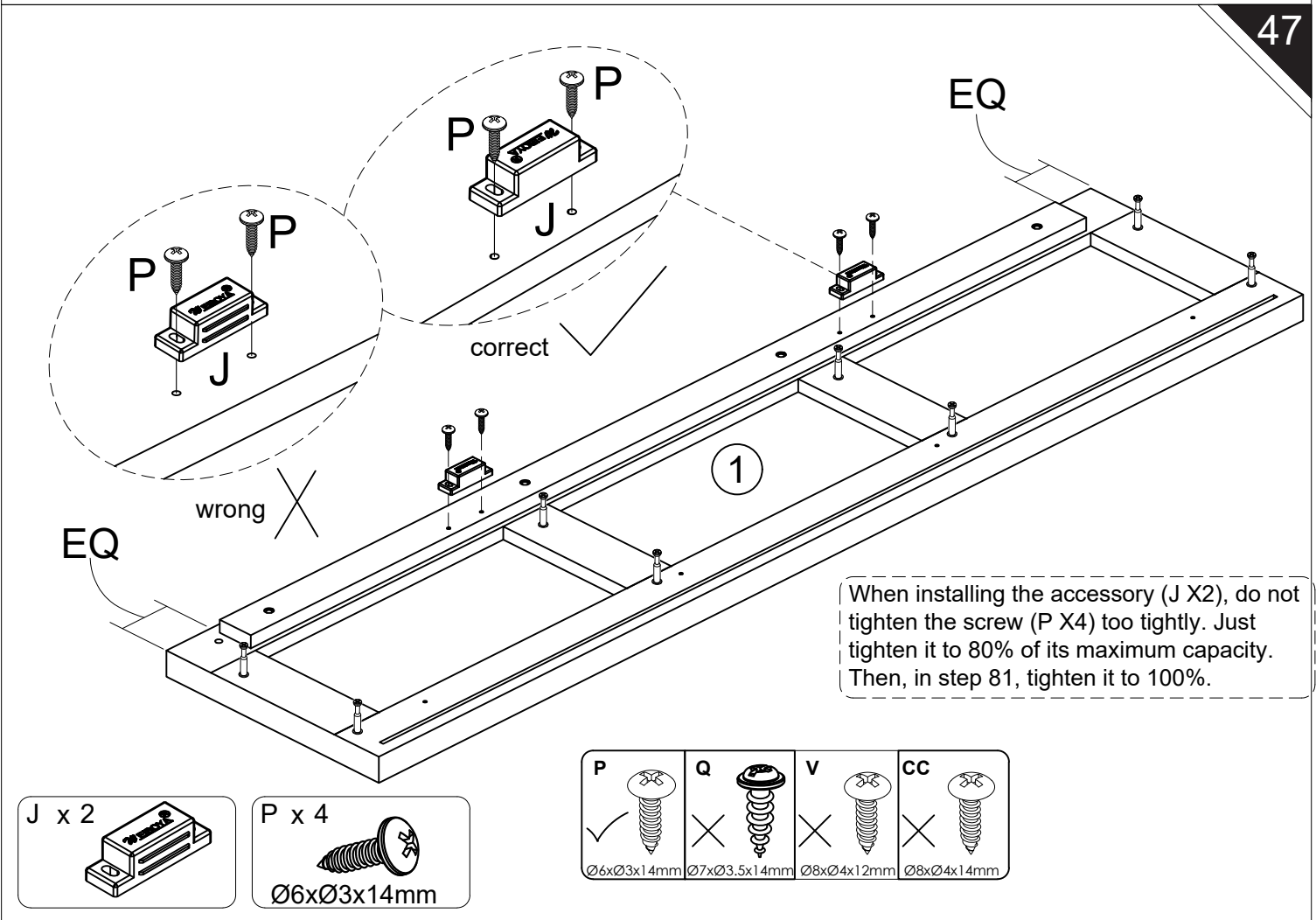
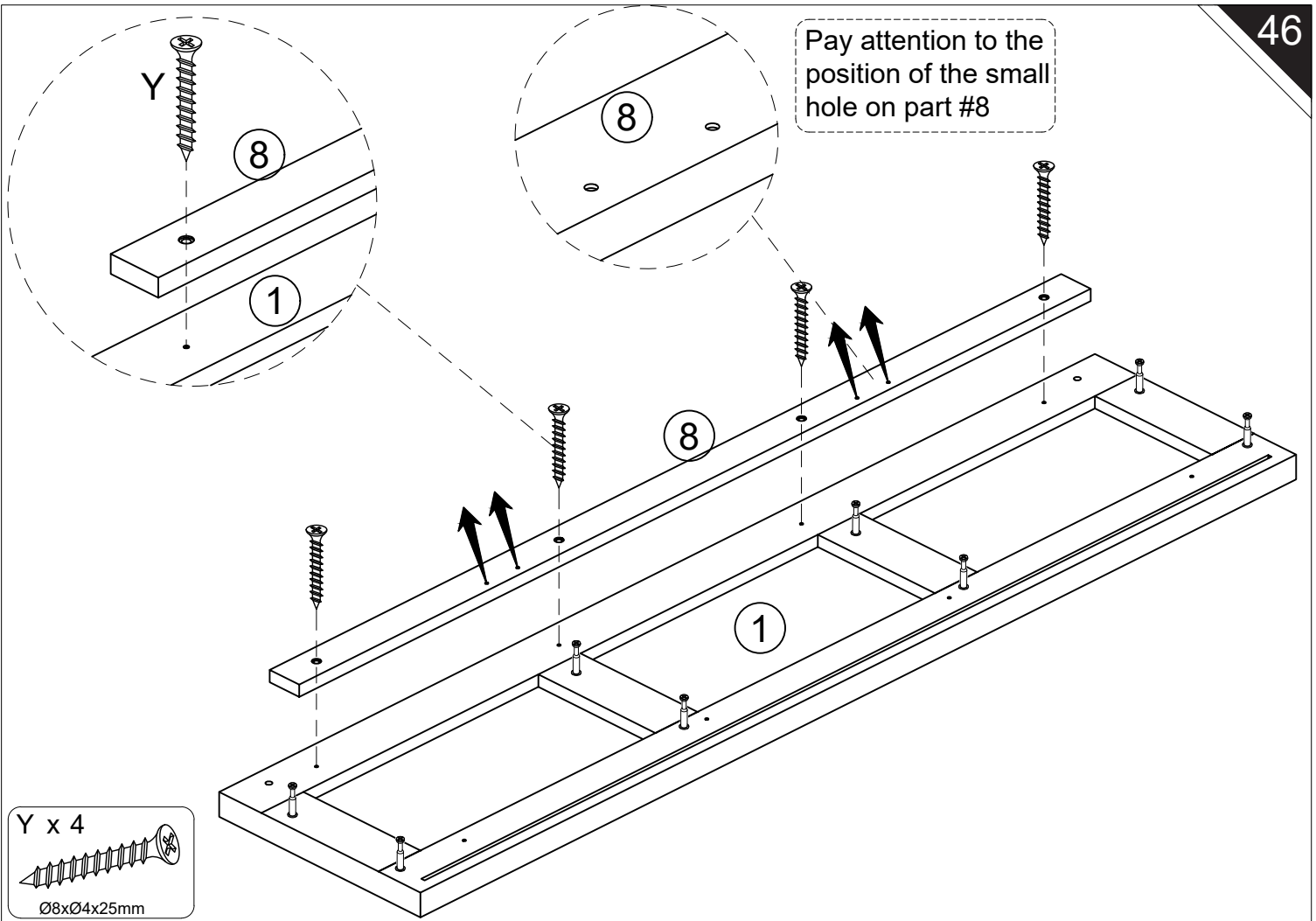

Please remove the film on the back of the lamp before installing the lamp strip to ensure that the lamp strip can be adhered to the board

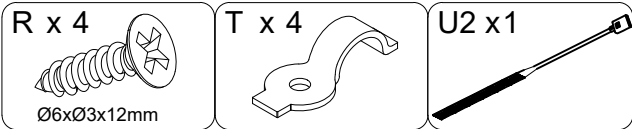
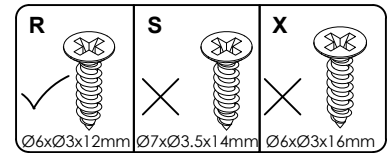
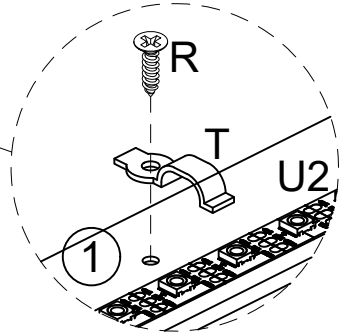
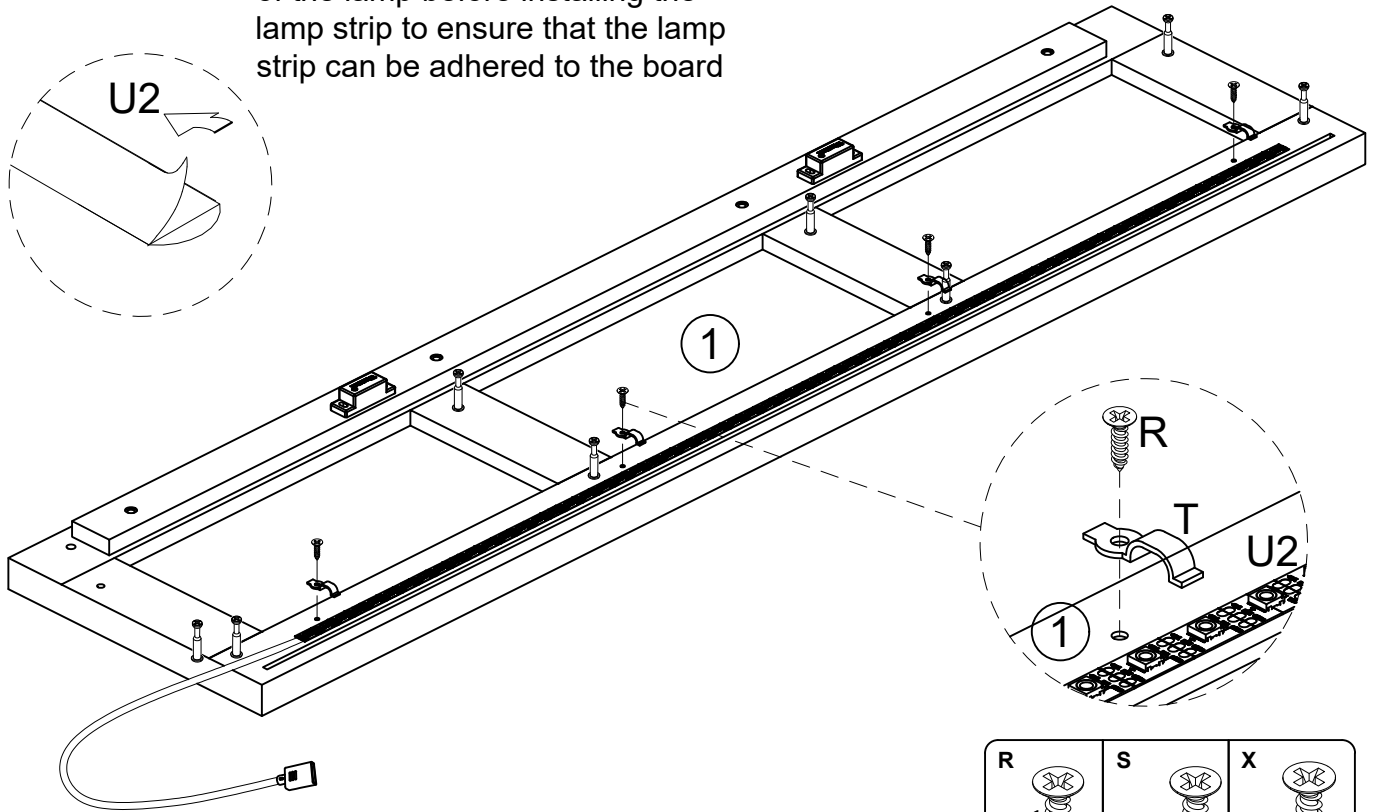
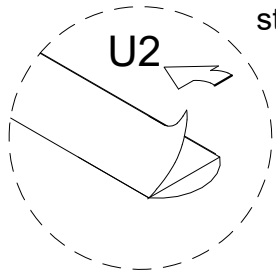

The thin plate needs to be fully inserted into the groove. If the insertion is not smooth, you can try pressing from the front or the back to make adjustments until the thin plate is fully inserted into the groove.

The grooves and the light strips are located on the back side of this part.

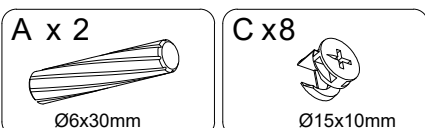
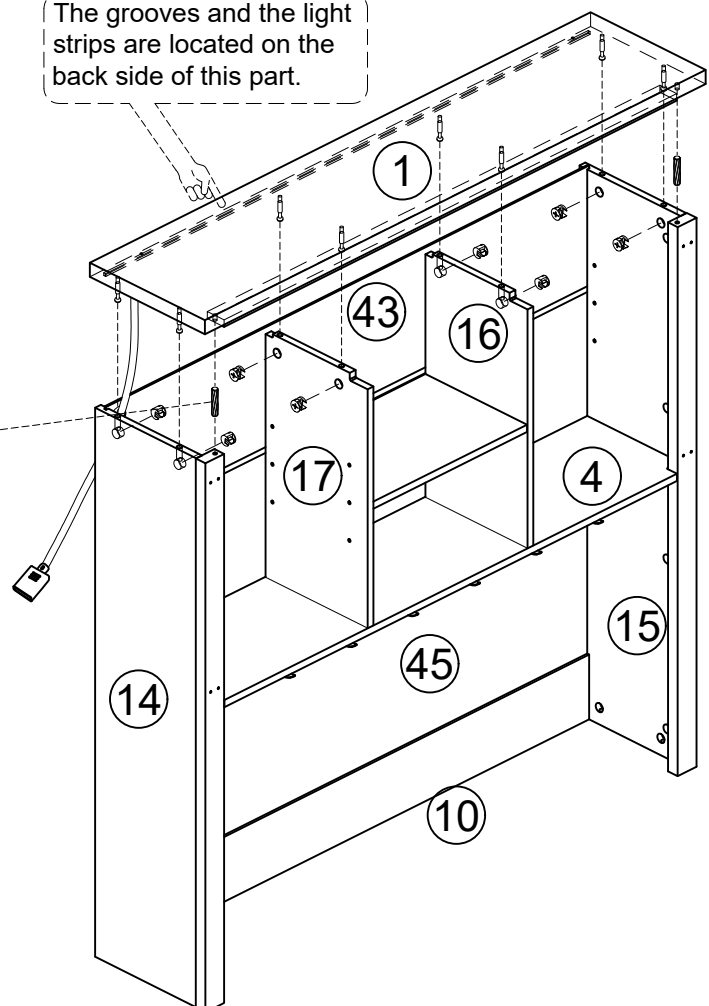
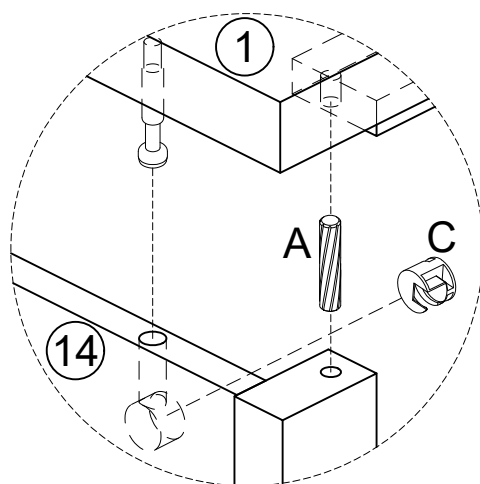

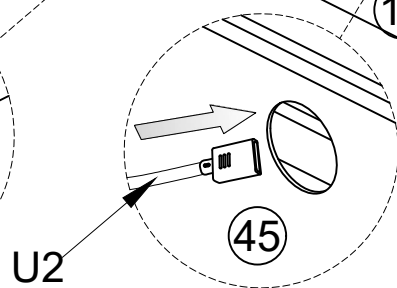
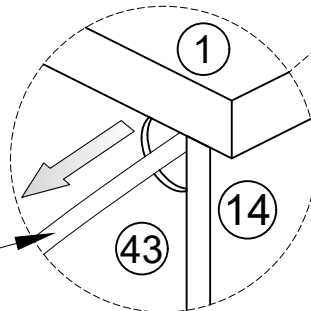
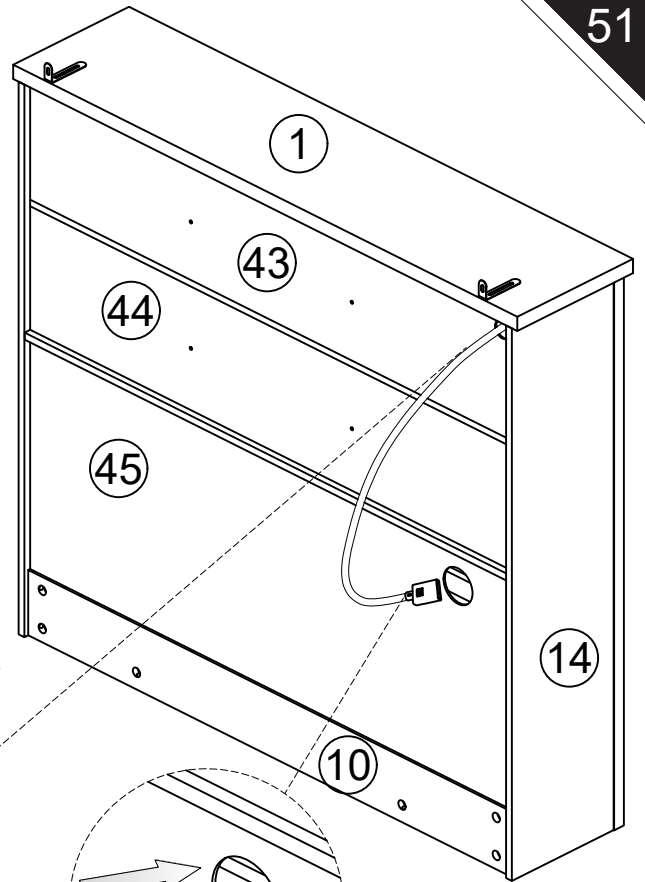
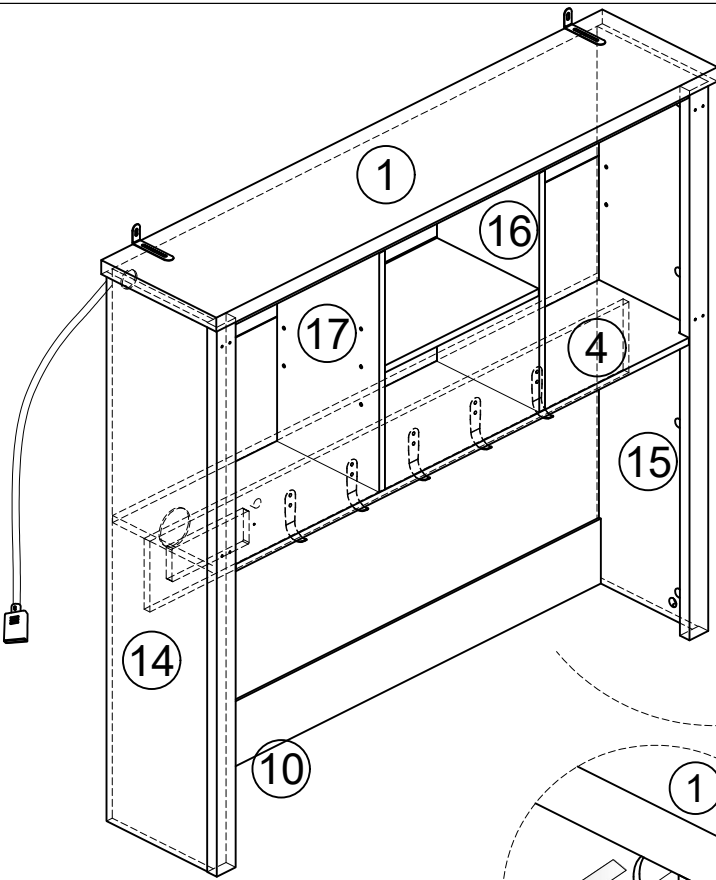
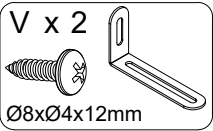
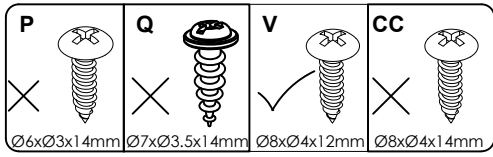
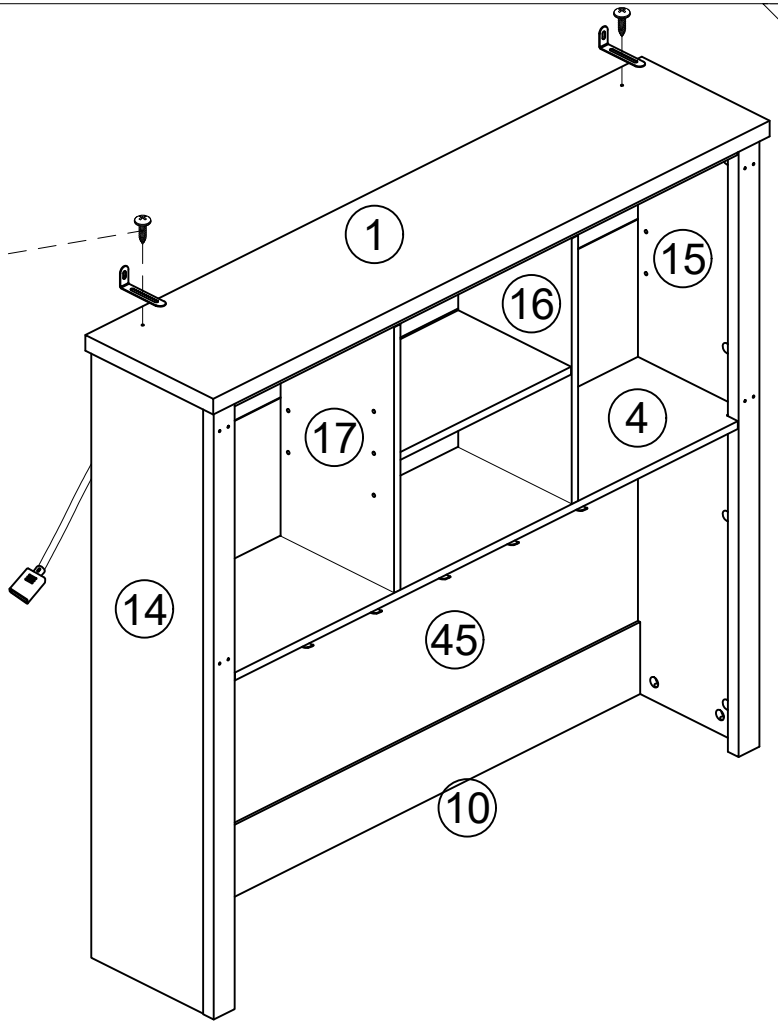
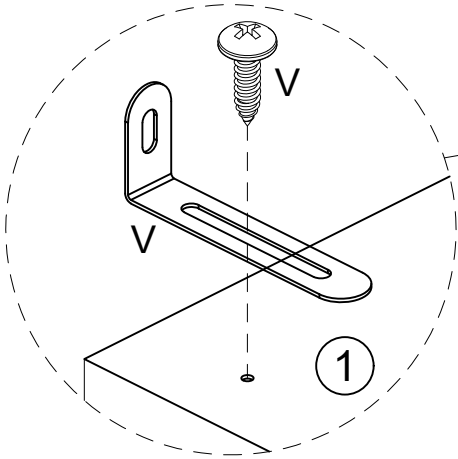

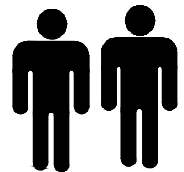
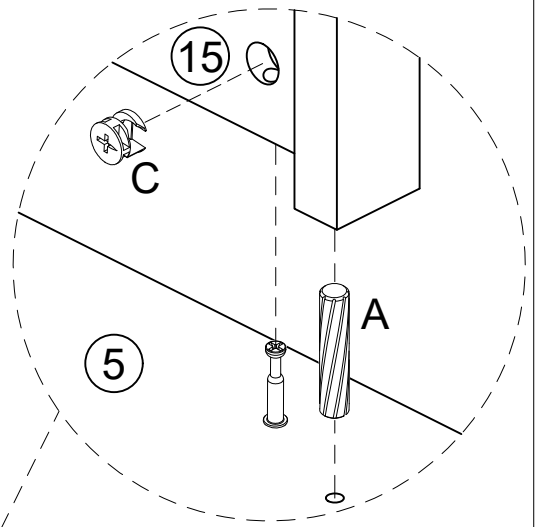
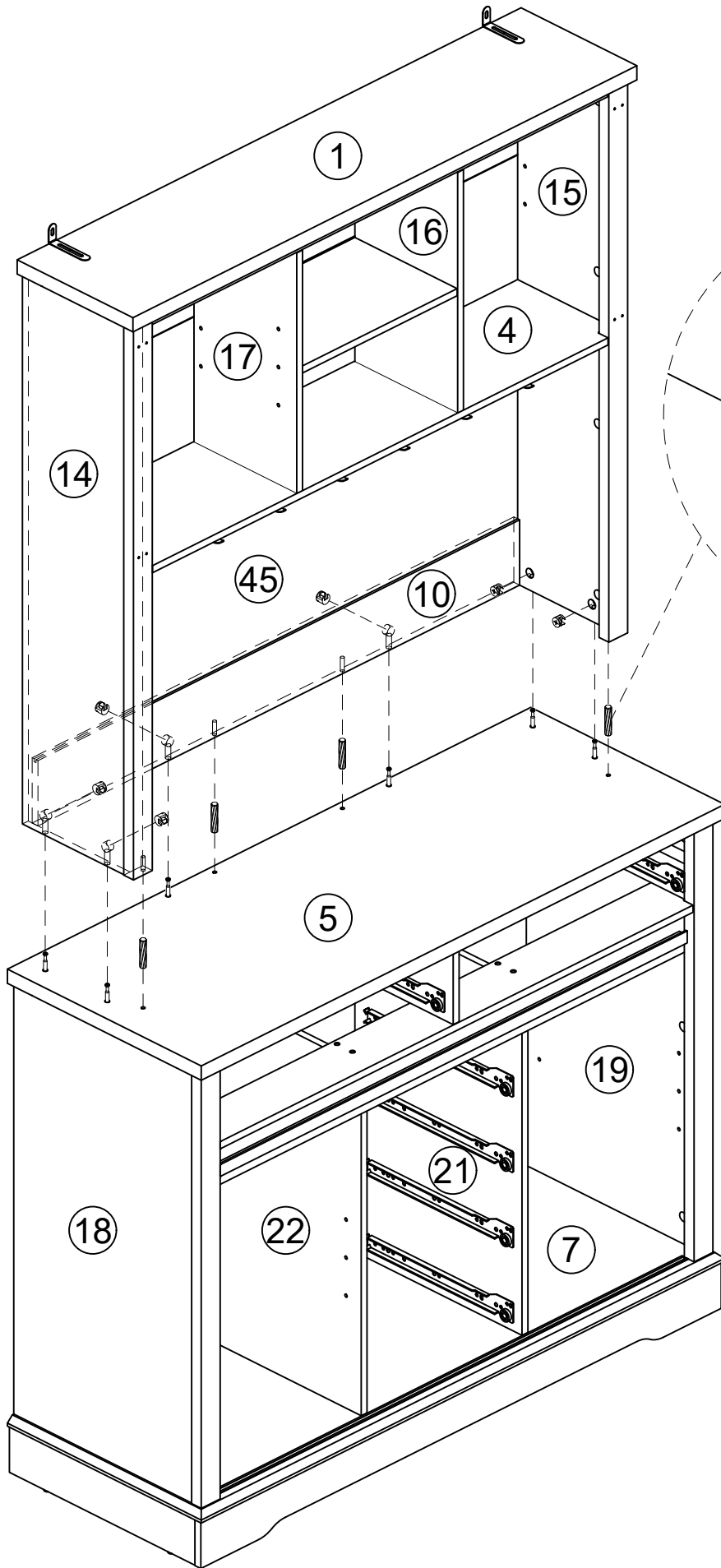

This installation step takes two people to complete

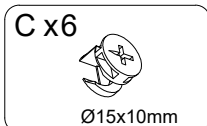
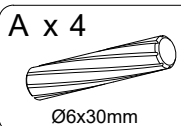

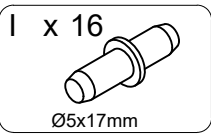
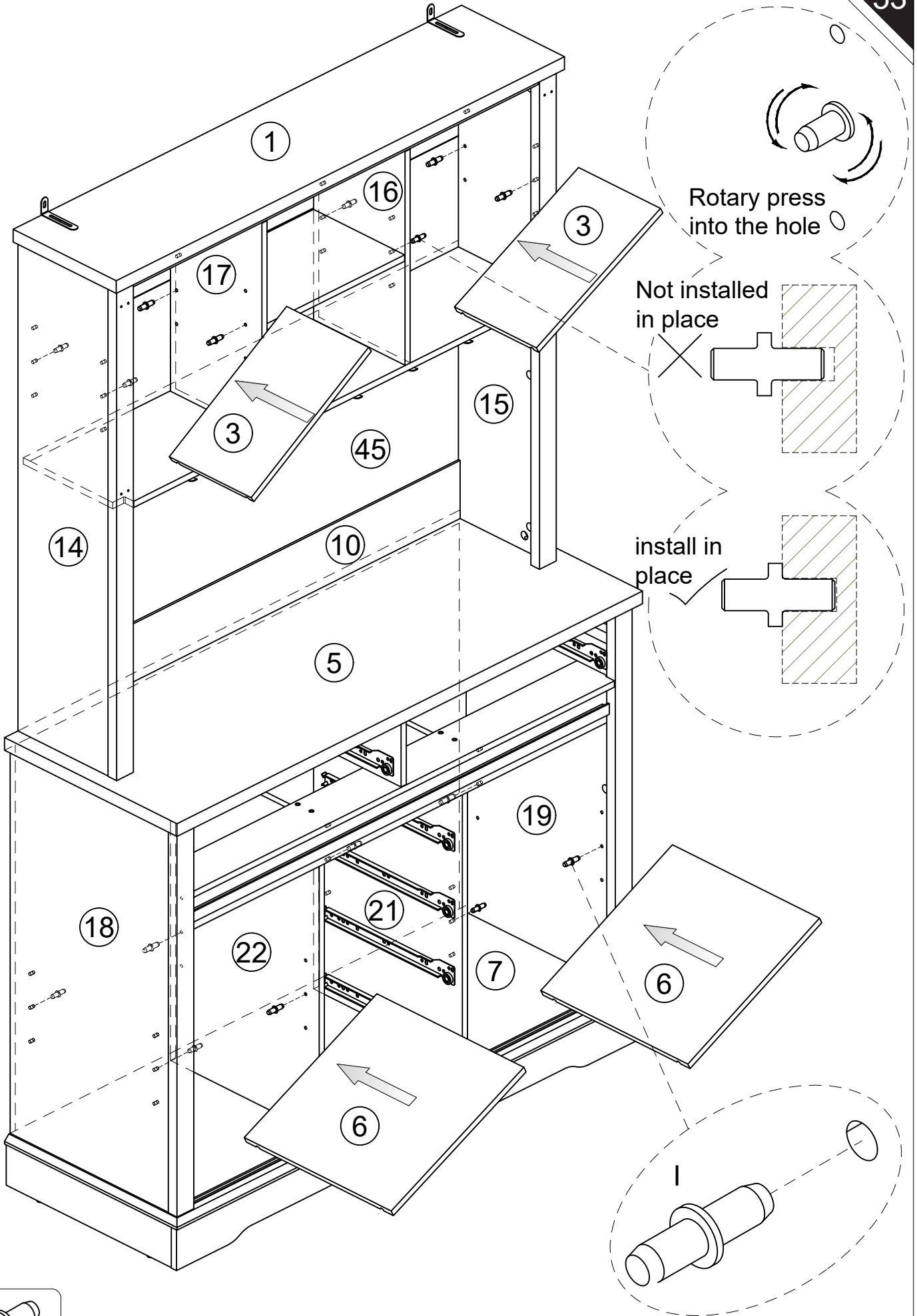

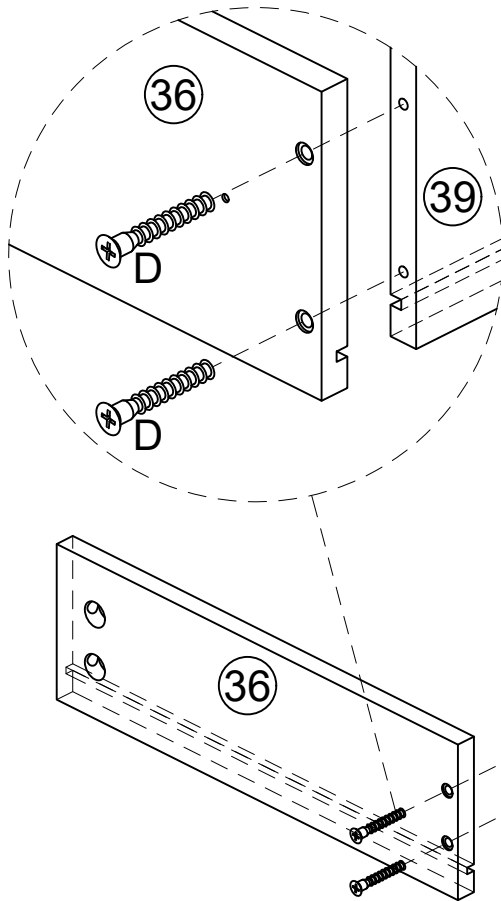

# X 4

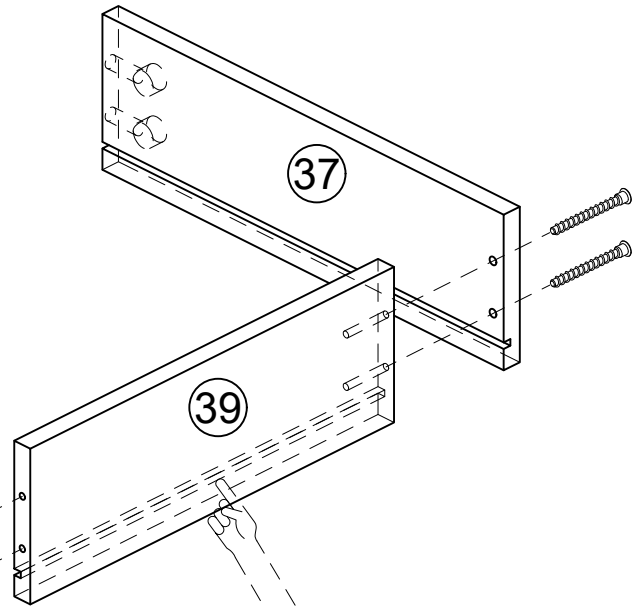

Notice that the groove is on the reverse side

D x 16

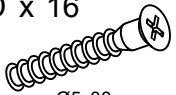

Ø5x38mm

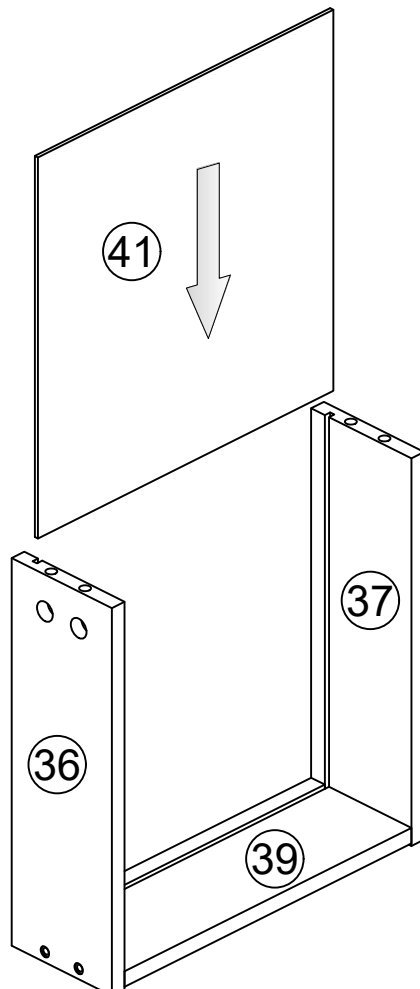

The thin plate needs to be fully inserted into the groove. If the insertion is not smooth, you can try pressing from the front or the back to make adjustments until the thin plate is fully inserted into the groove.

# X 4

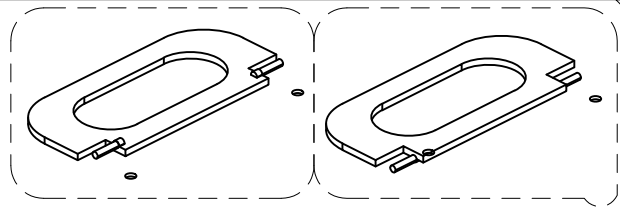
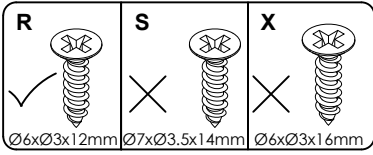

correct ✓

wrong ✗

Pay attention to the direction of the shaft column. The shaft column should be on the top.

# X 4

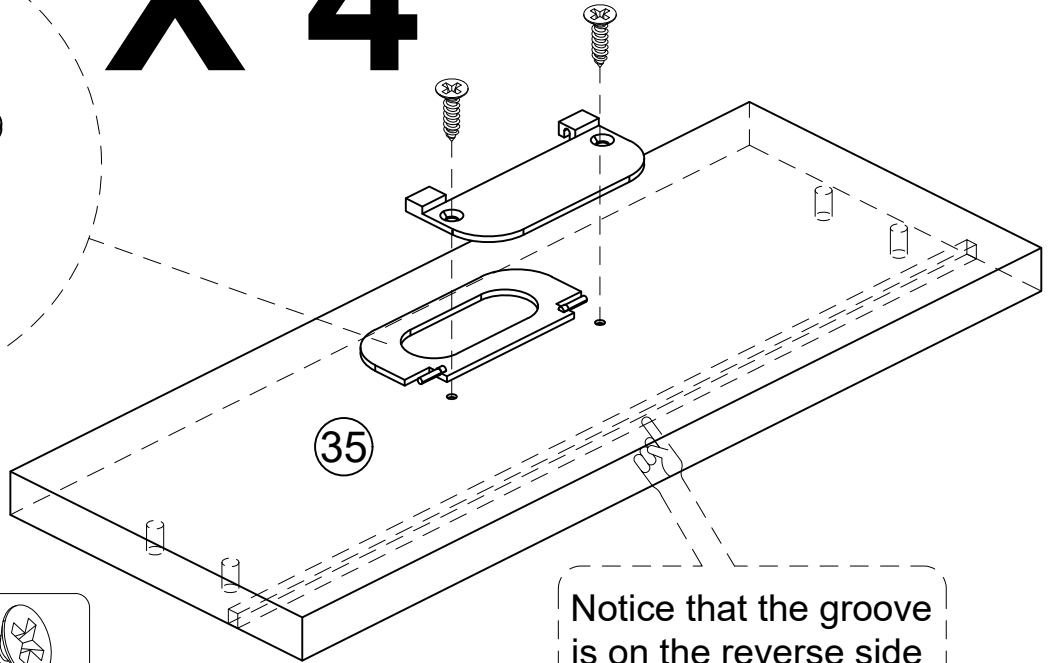
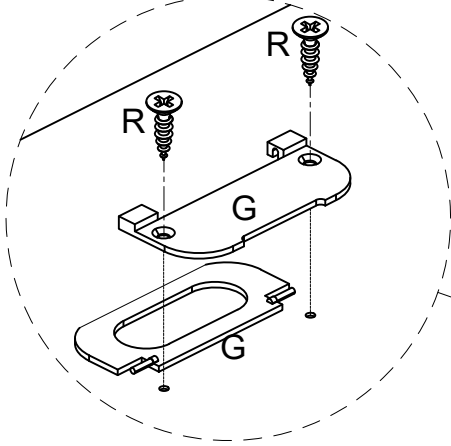

Notice that the groove is on the reverse side

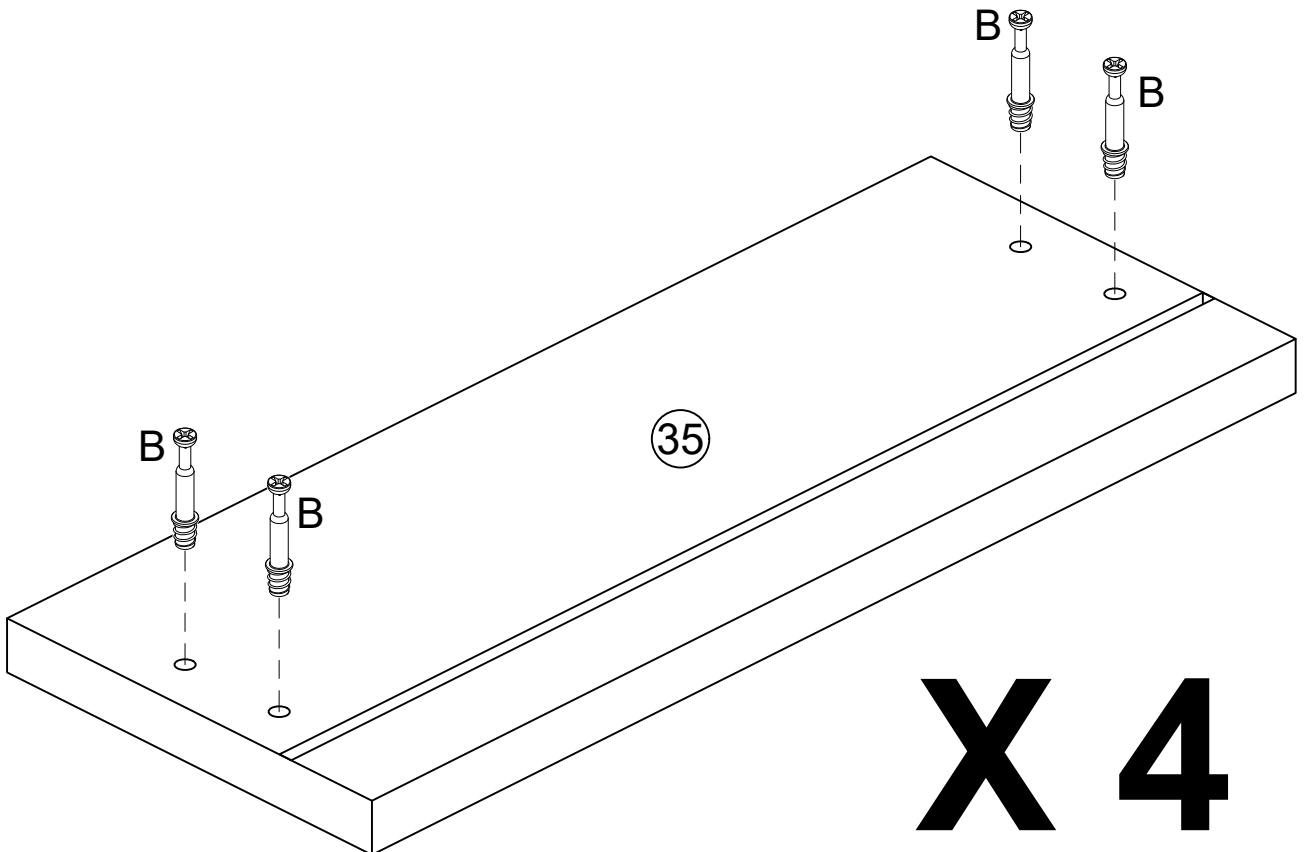
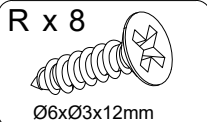

# X 4

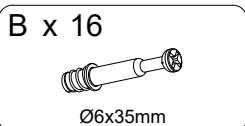



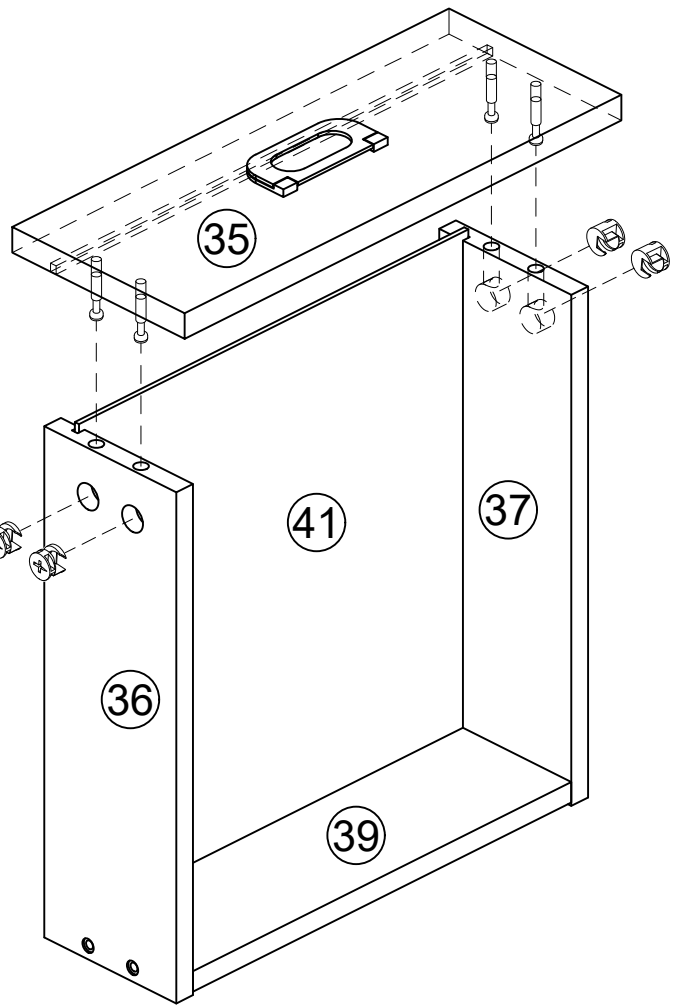
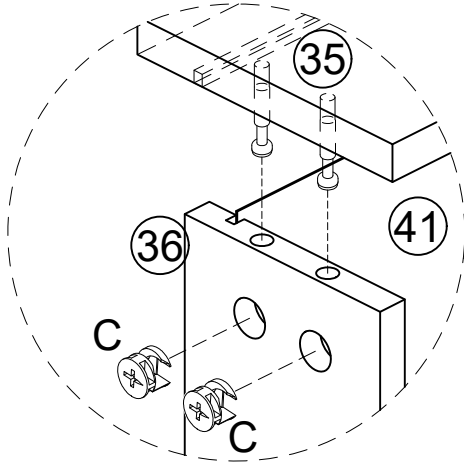

The thin plate needs to be fully inserted into the groove. If the insertion is not smooth, you can try pressing from the front or the back to make adjustments until the thin plate is fully inserted into the groove.

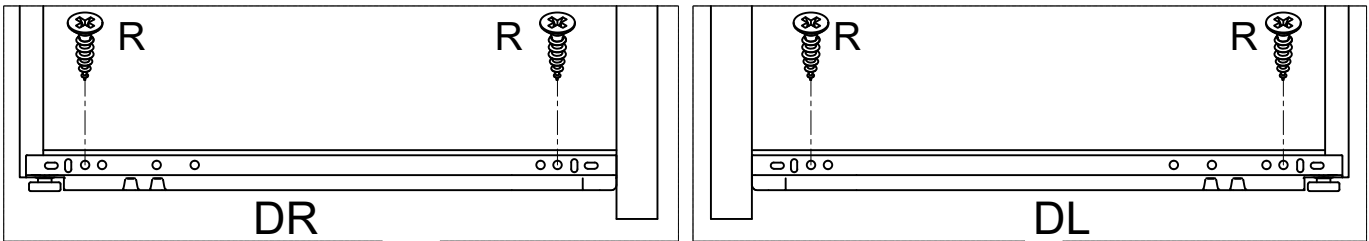

**X 4**

C x 16  
  
 Ø15x10mm



R	S	X
		
✓ Ø6xØ3x12mm	✗ Ø7xØ3.5x14mm	✗ Ø6xØ3x16mm

**X 4**

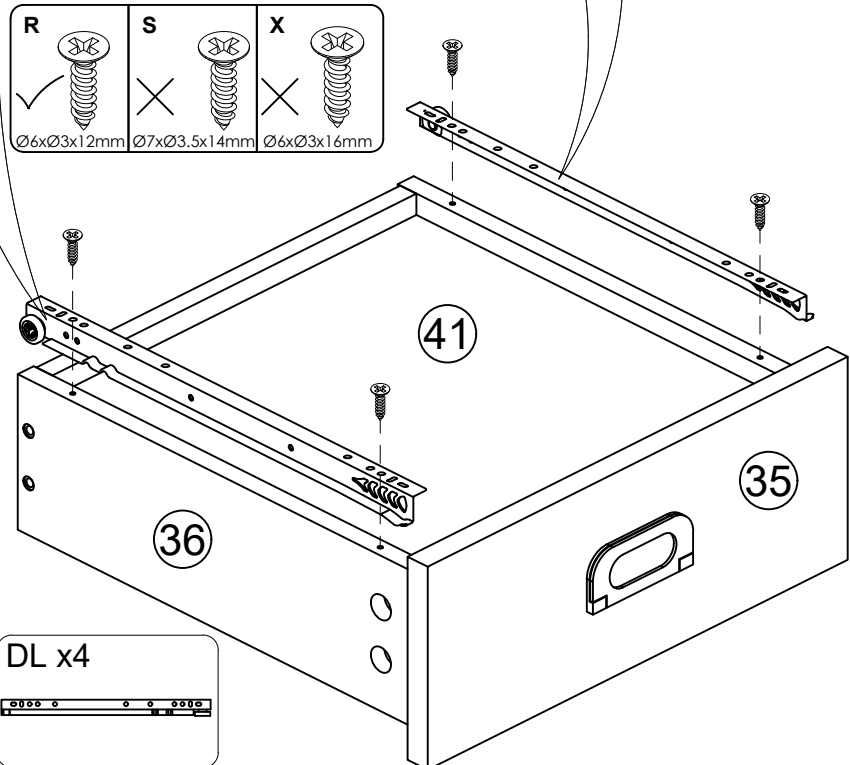

R x 16  
  
 Ø6x3x12

DR x 4  

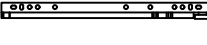
DL x 4  

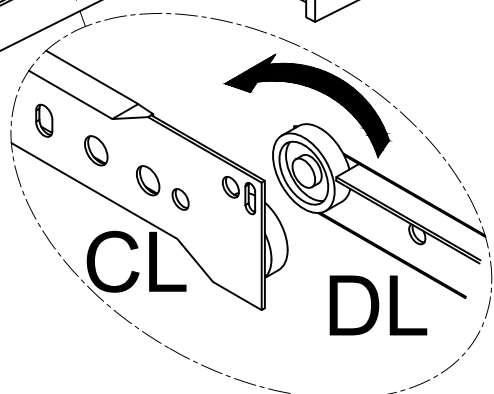
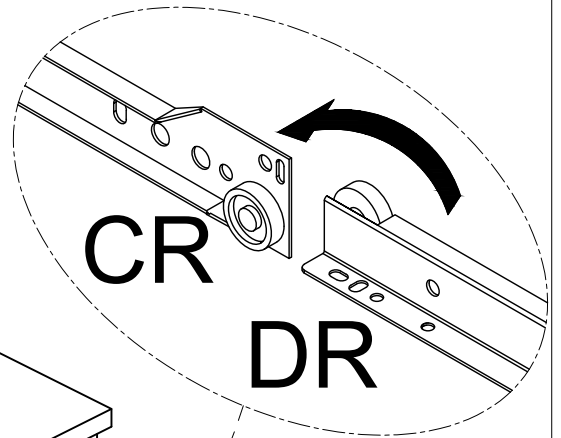
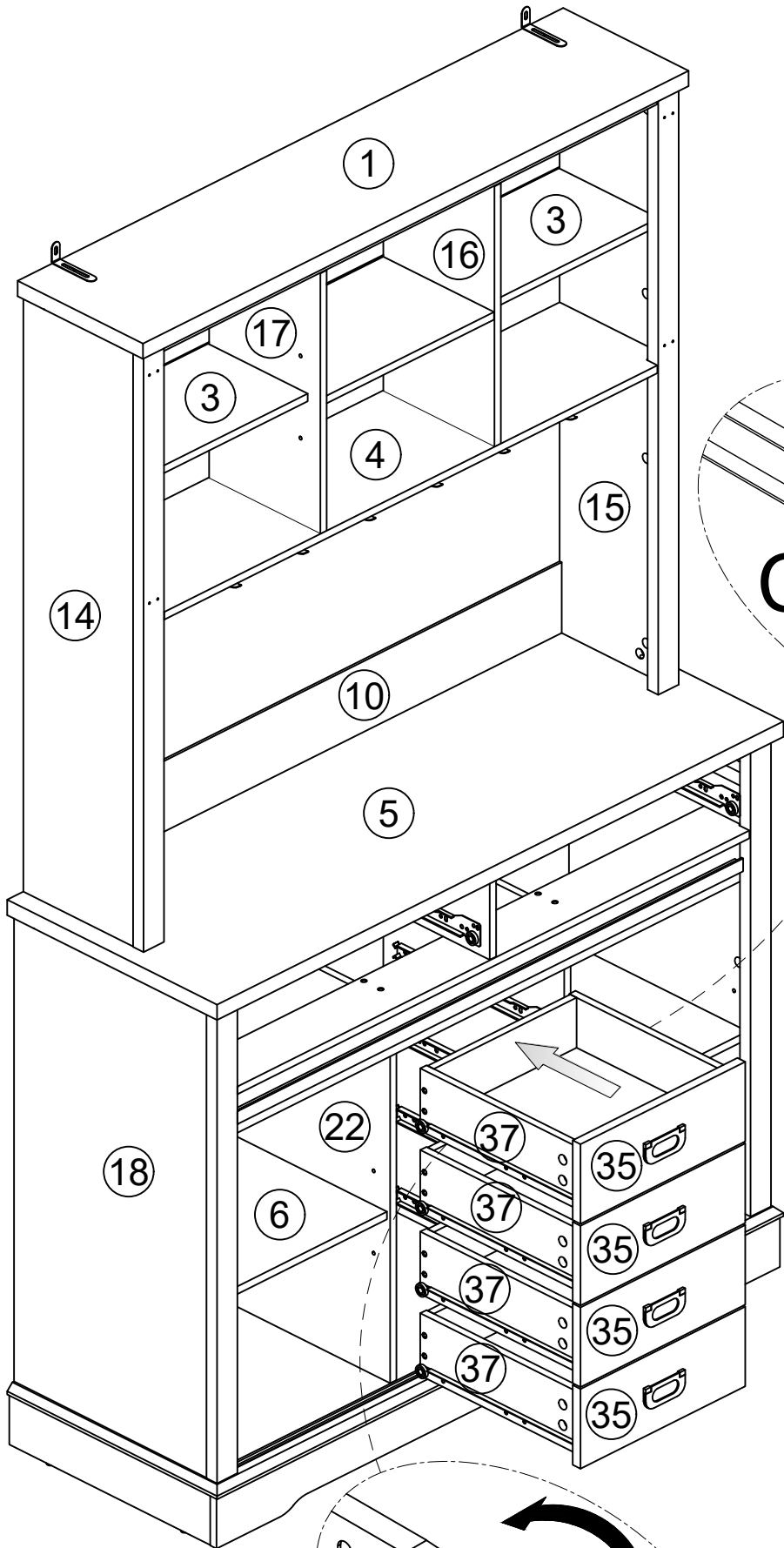

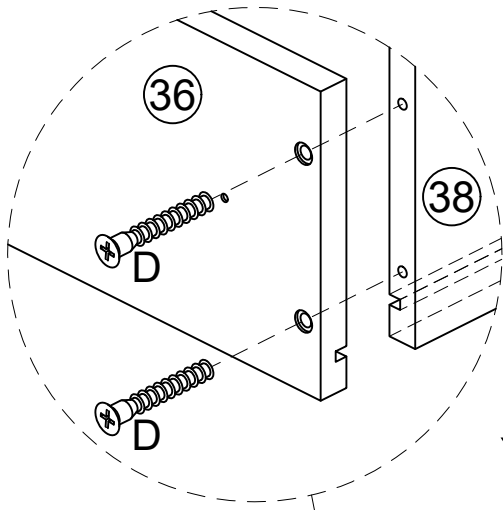

# X 2

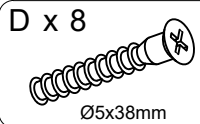
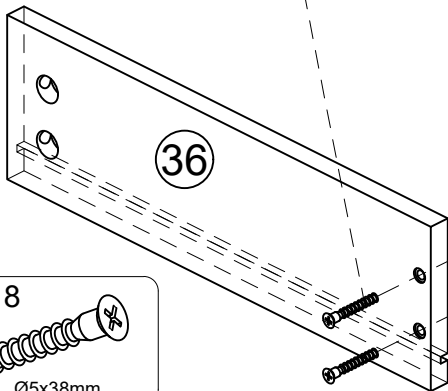
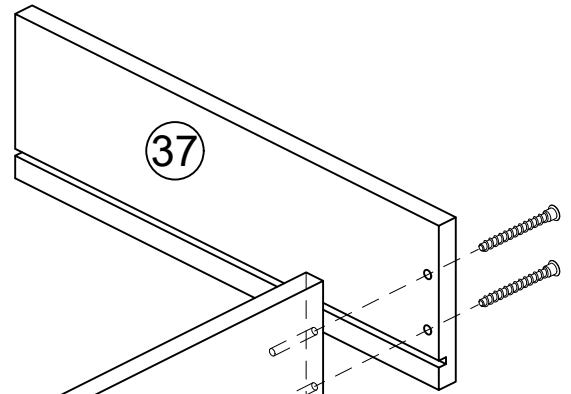

Notice that the groove is on the reverse side

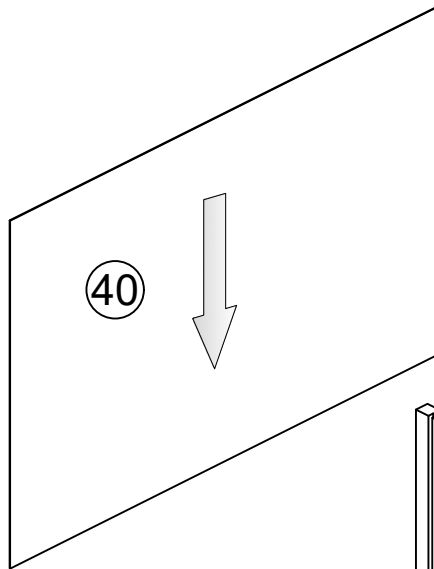

The thin plate needs to be fully inserted into the groove. If the insertion is not smooth, you can try pressing from the front or the back to make adjustments until the thin plate is fully inserted into the groove.

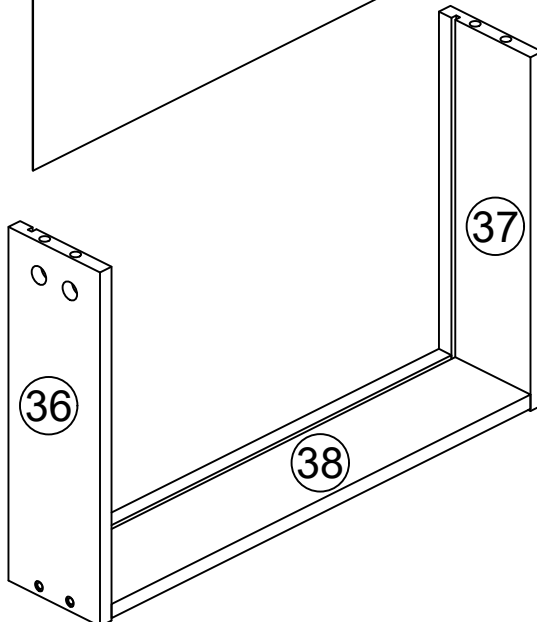

# X 2

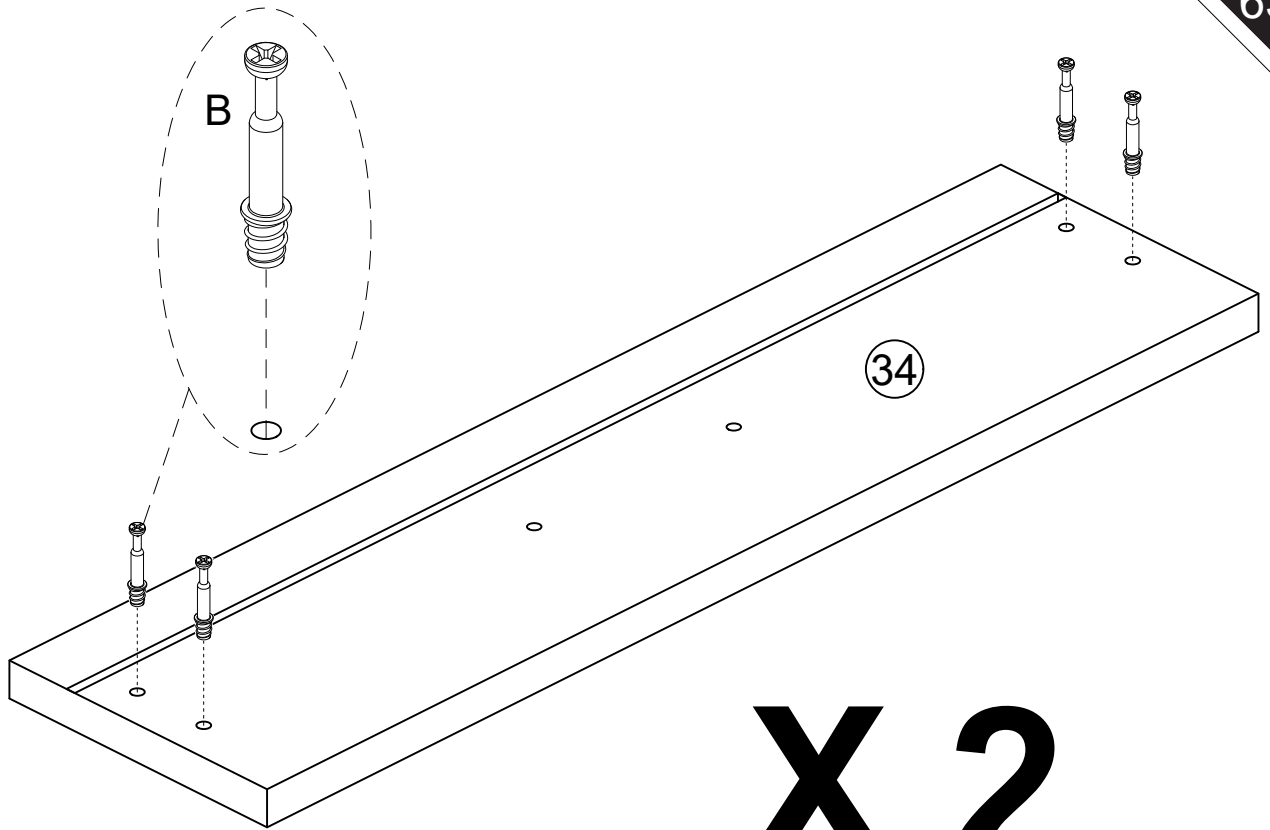

**X 2**

B x 8

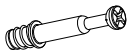

Ø6x35mm

The thin plate needs to be fully inserted into the groove. If the insertion is not smooth, you can try pressing from the front or the back to make adjustments until the thin plate is fully inserted into the groove.

Notice that the groove is on the reverse side

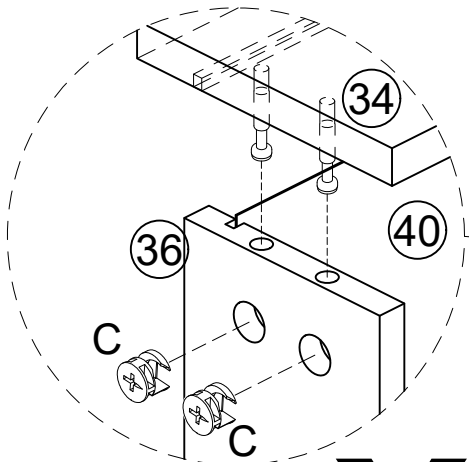
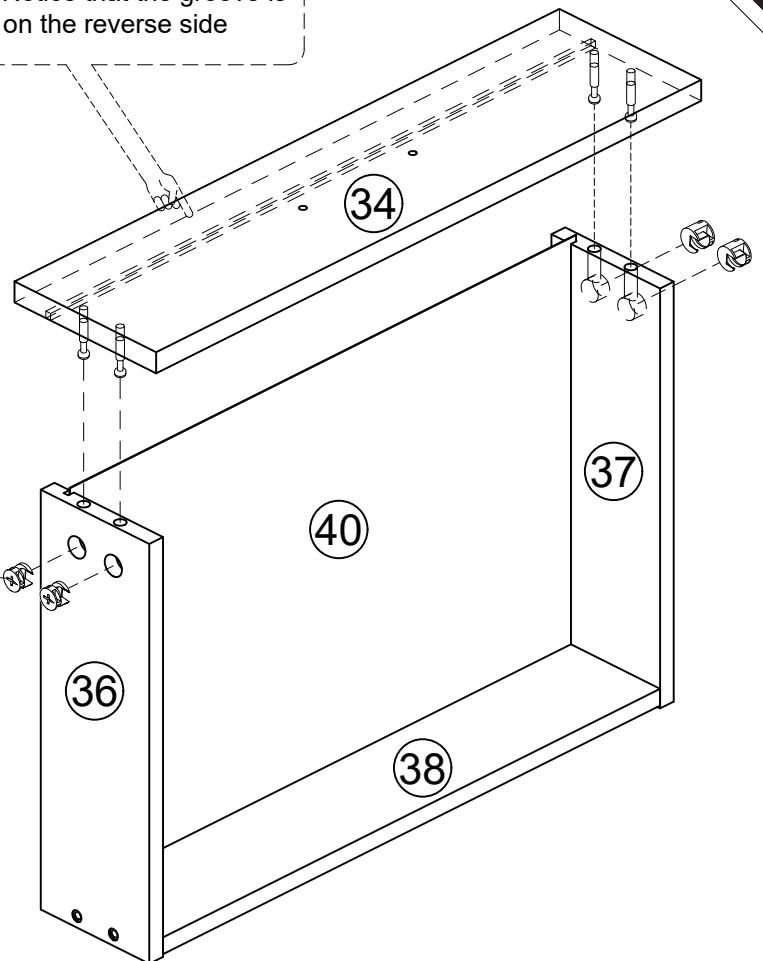

**X 2**

C x 8



Ø15x10mm

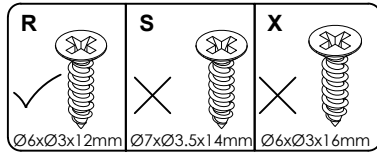
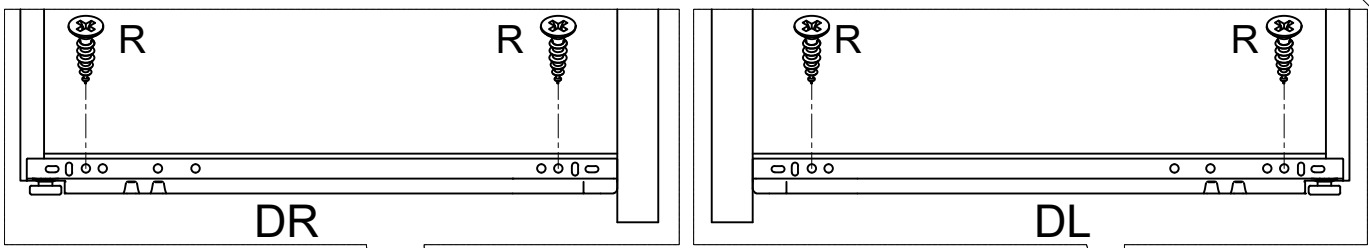

# X 2

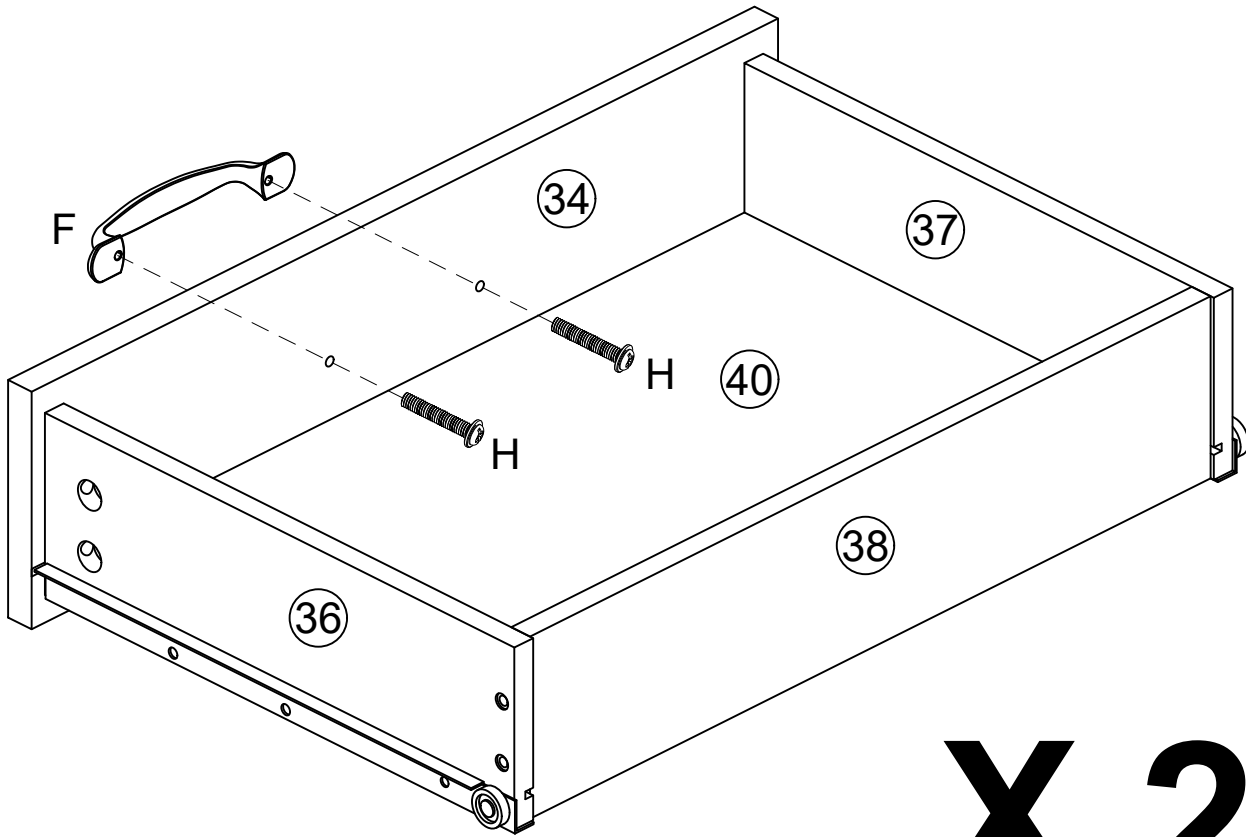
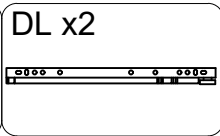
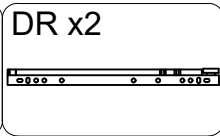
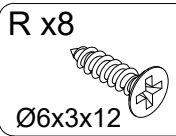
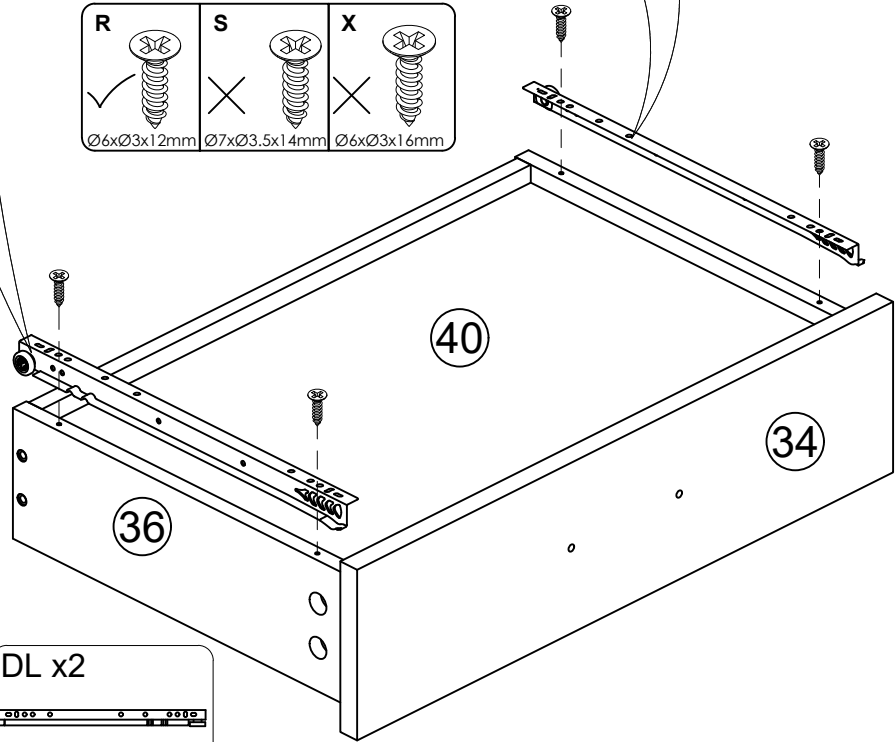

# X 2

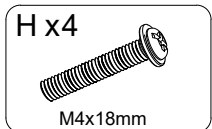
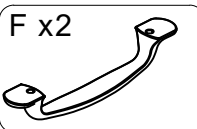

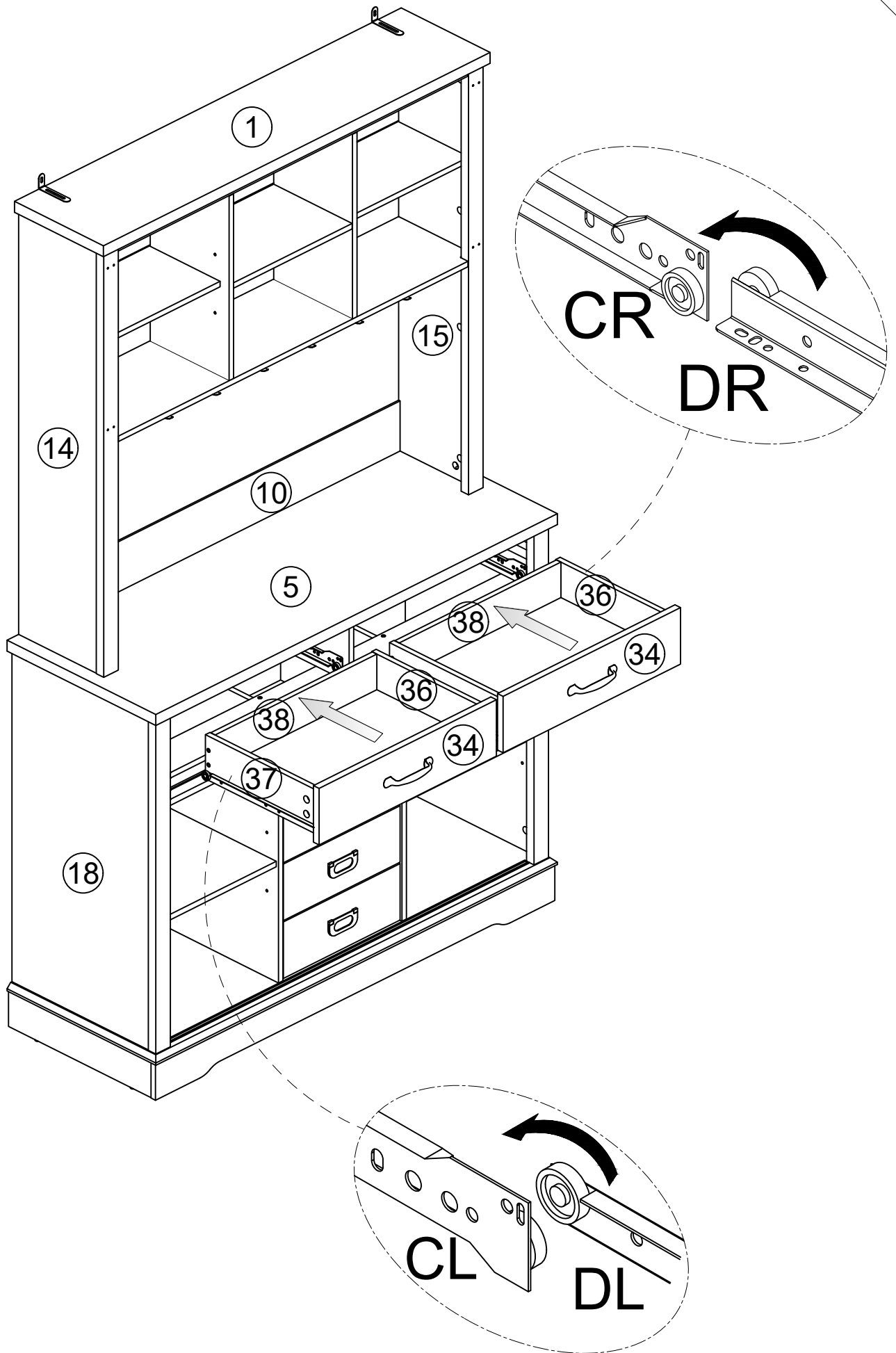

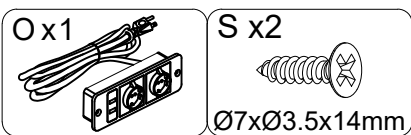
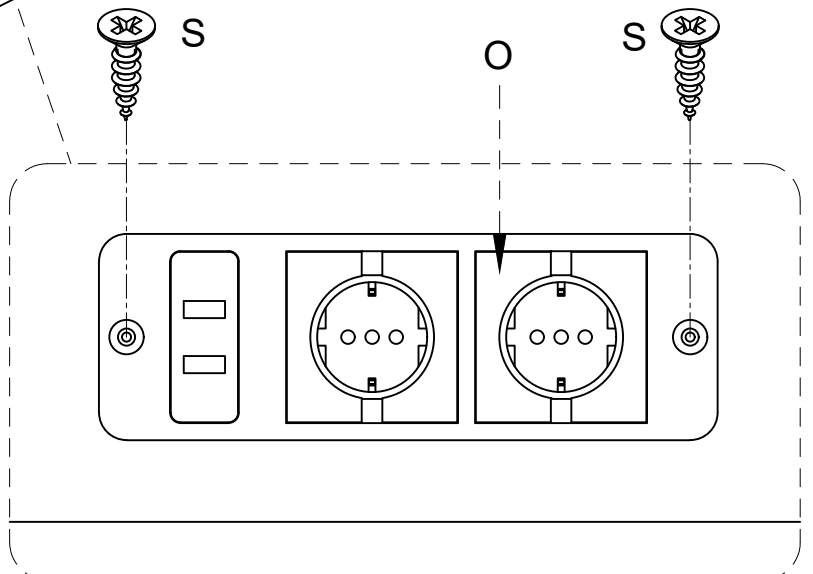
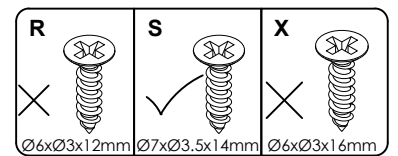
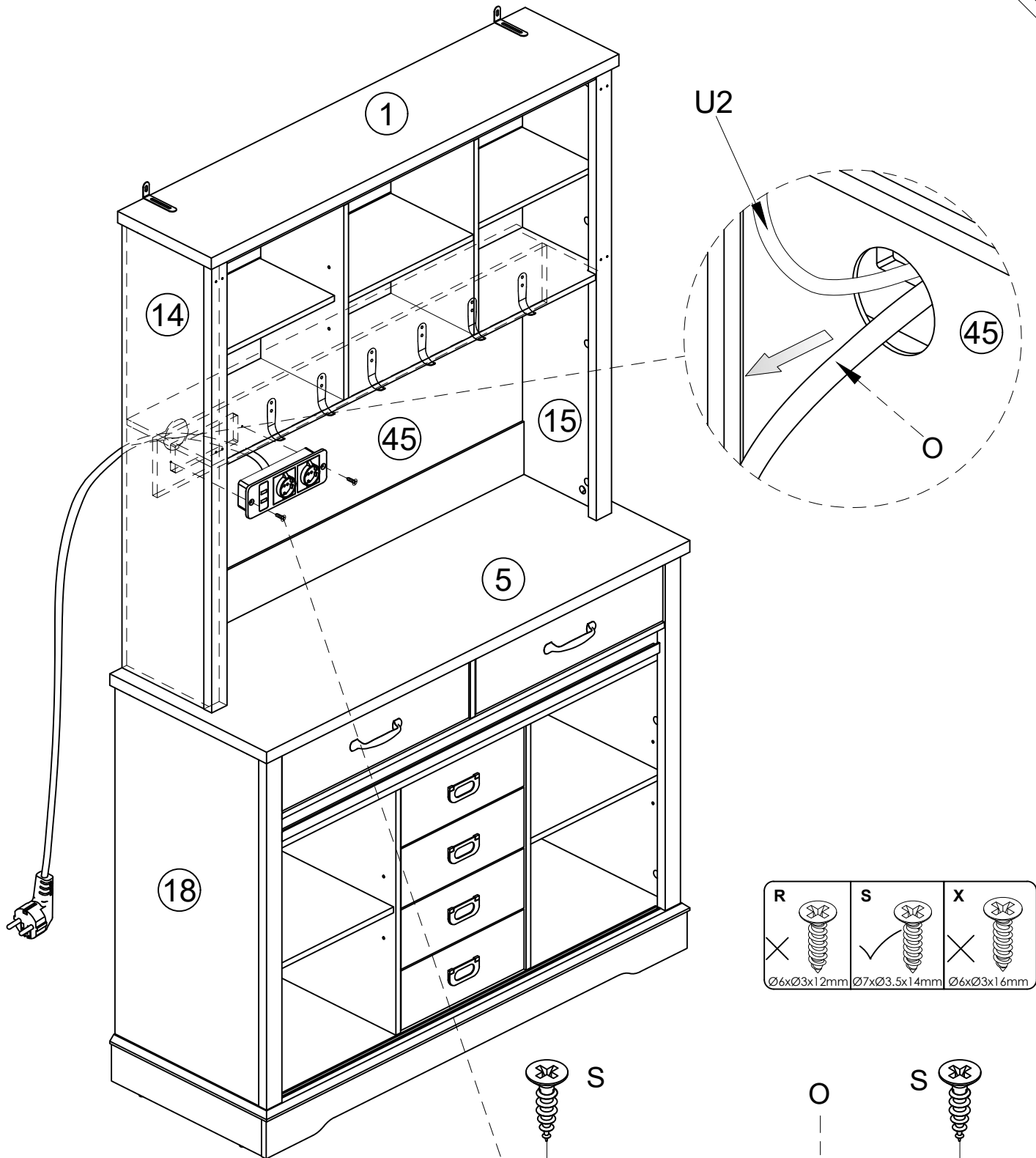

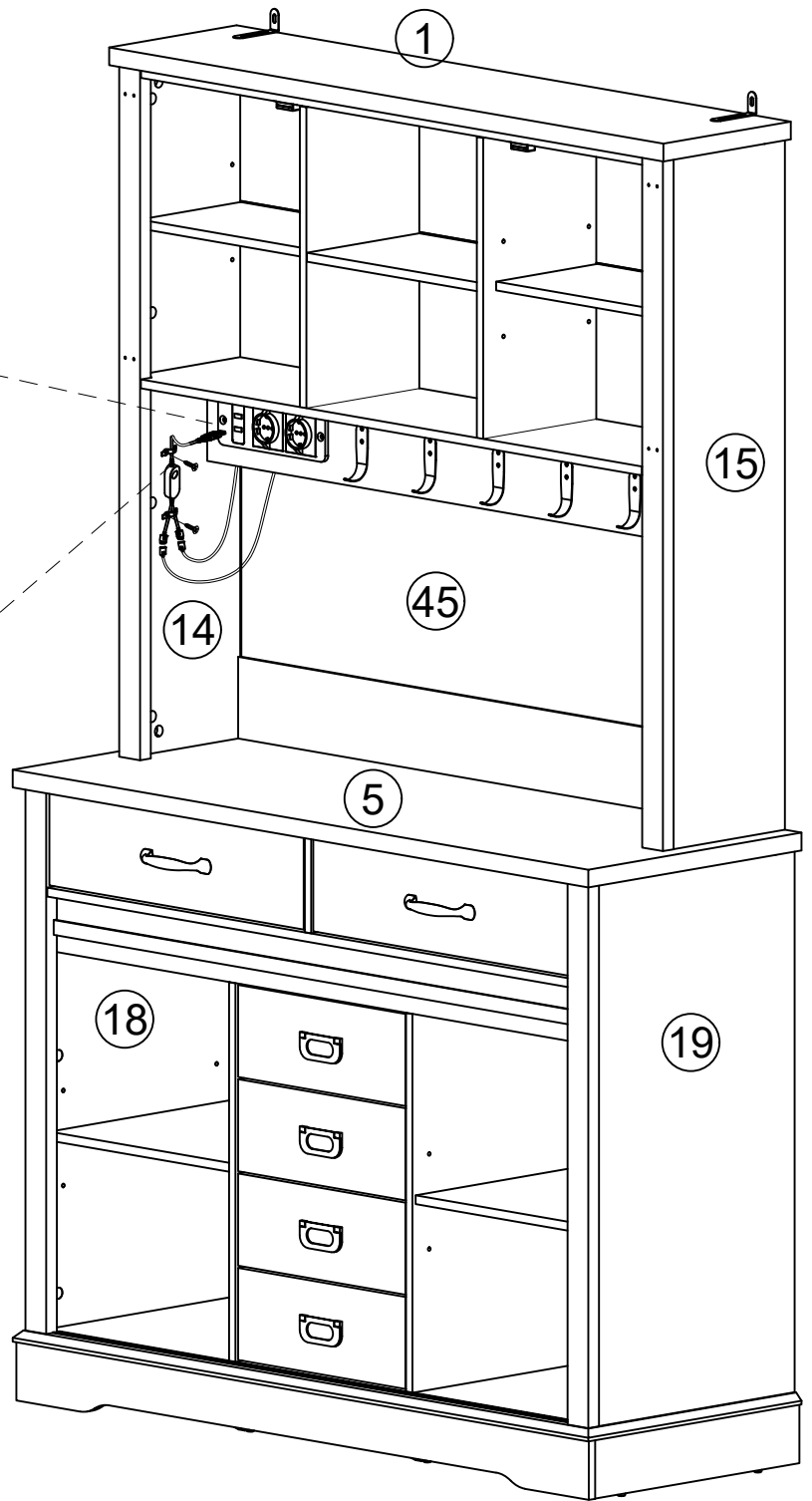
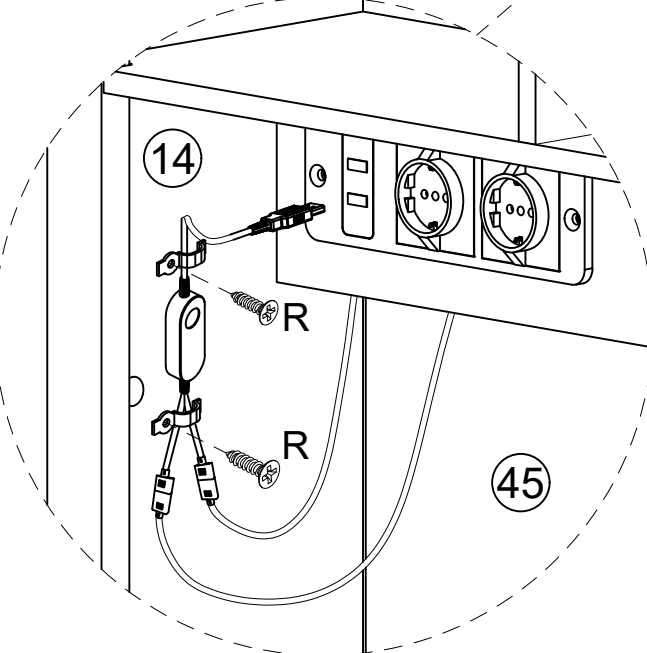
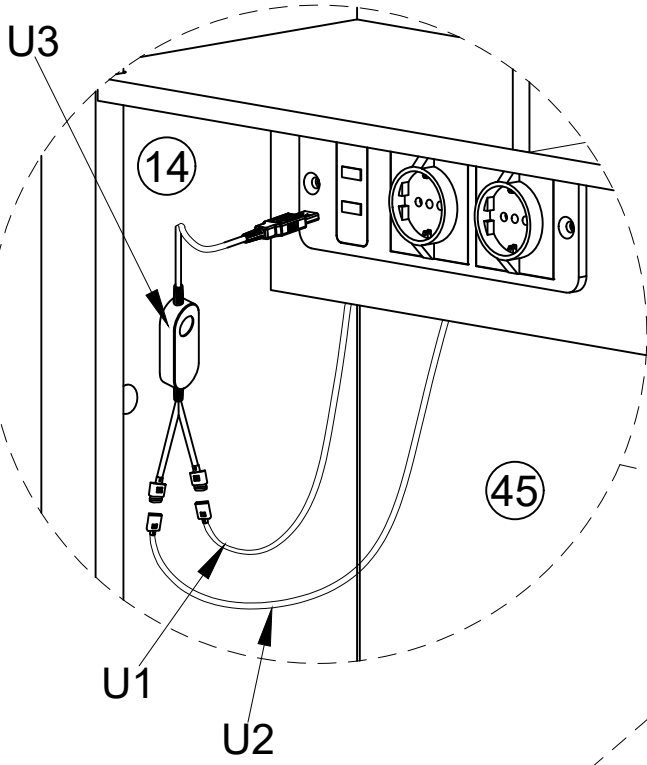

You can fold the grown-out thread and then screw it in place at the appropriate position.

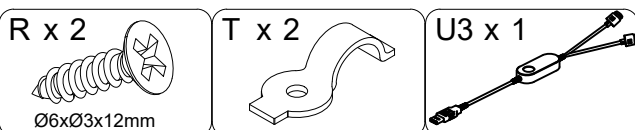
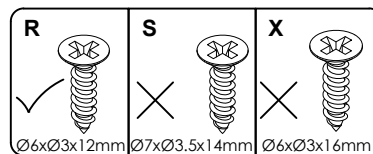

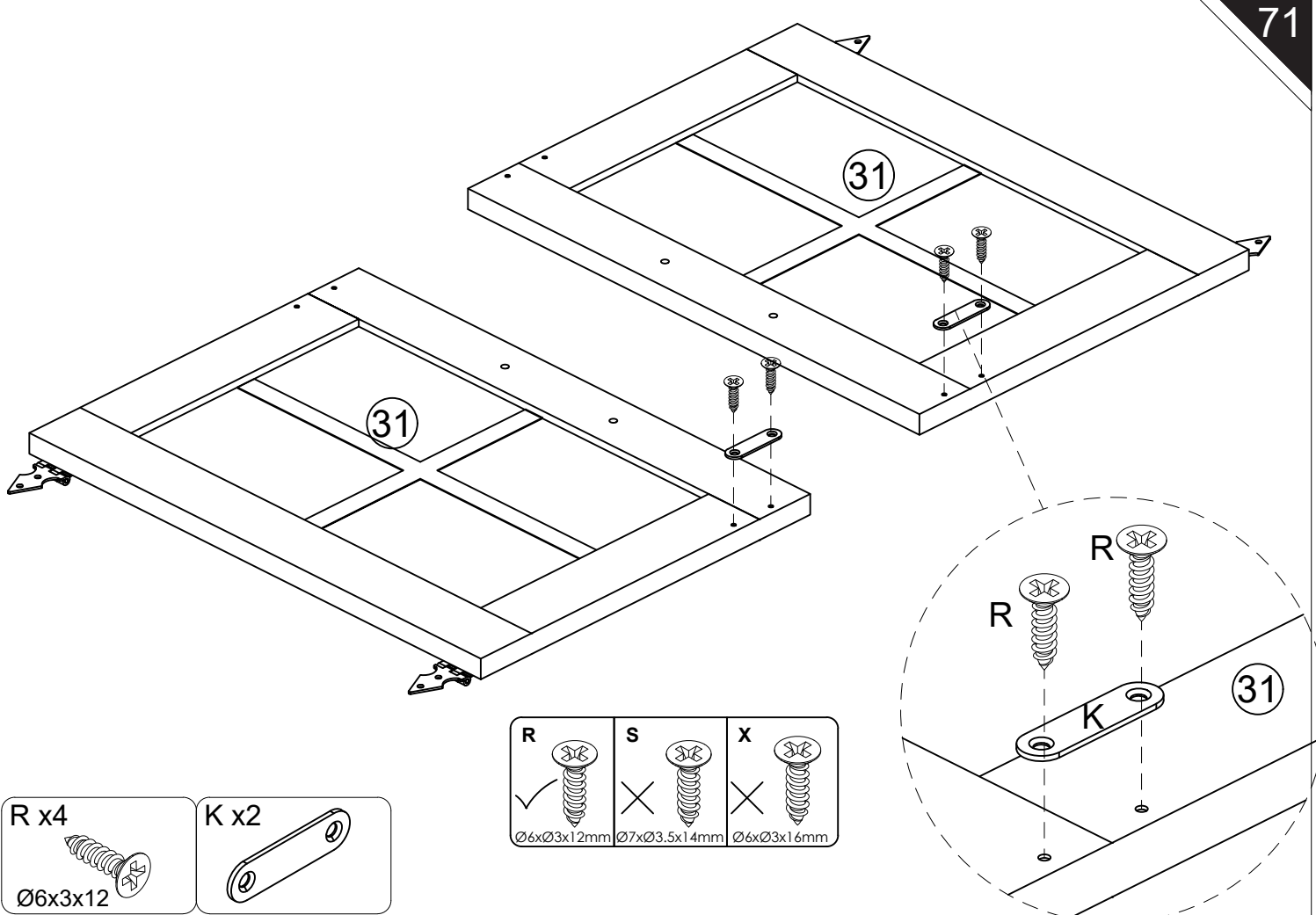
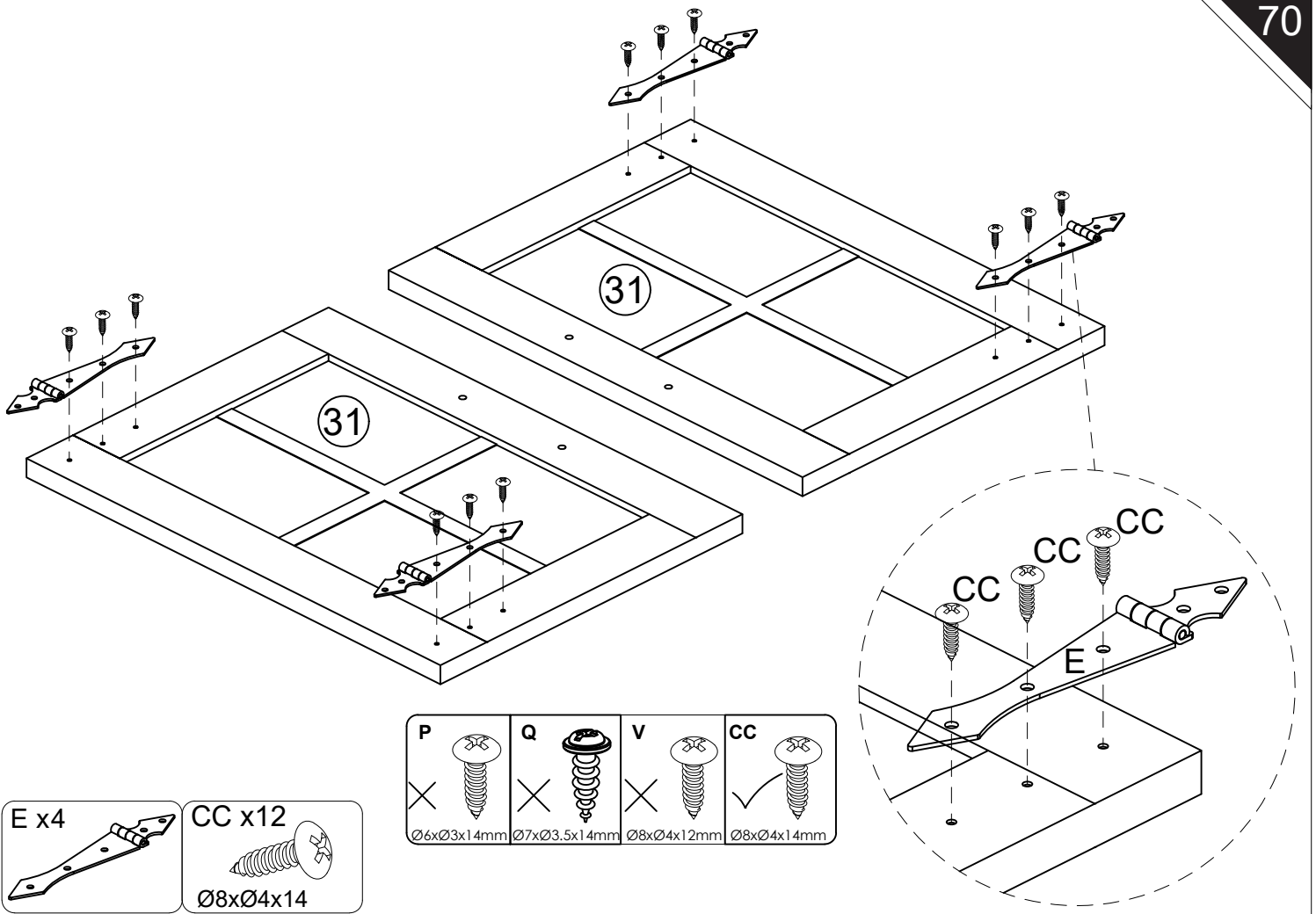

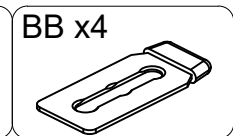
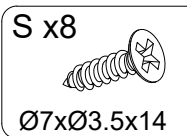
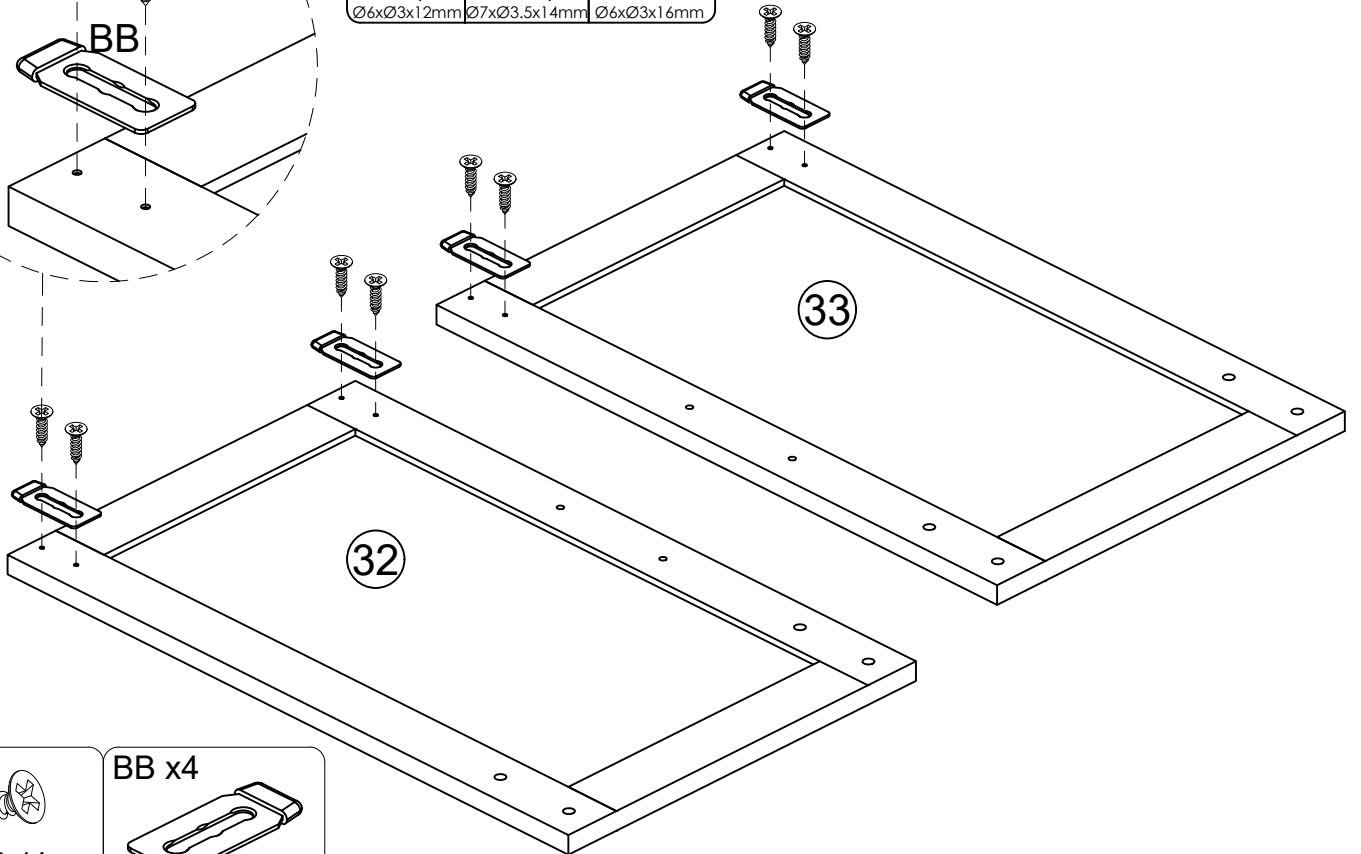
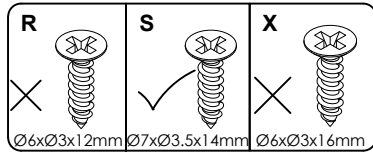
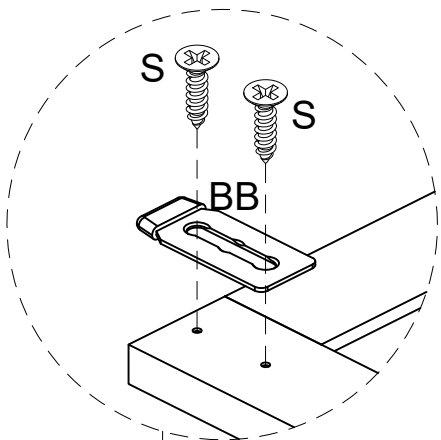
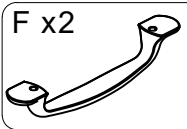
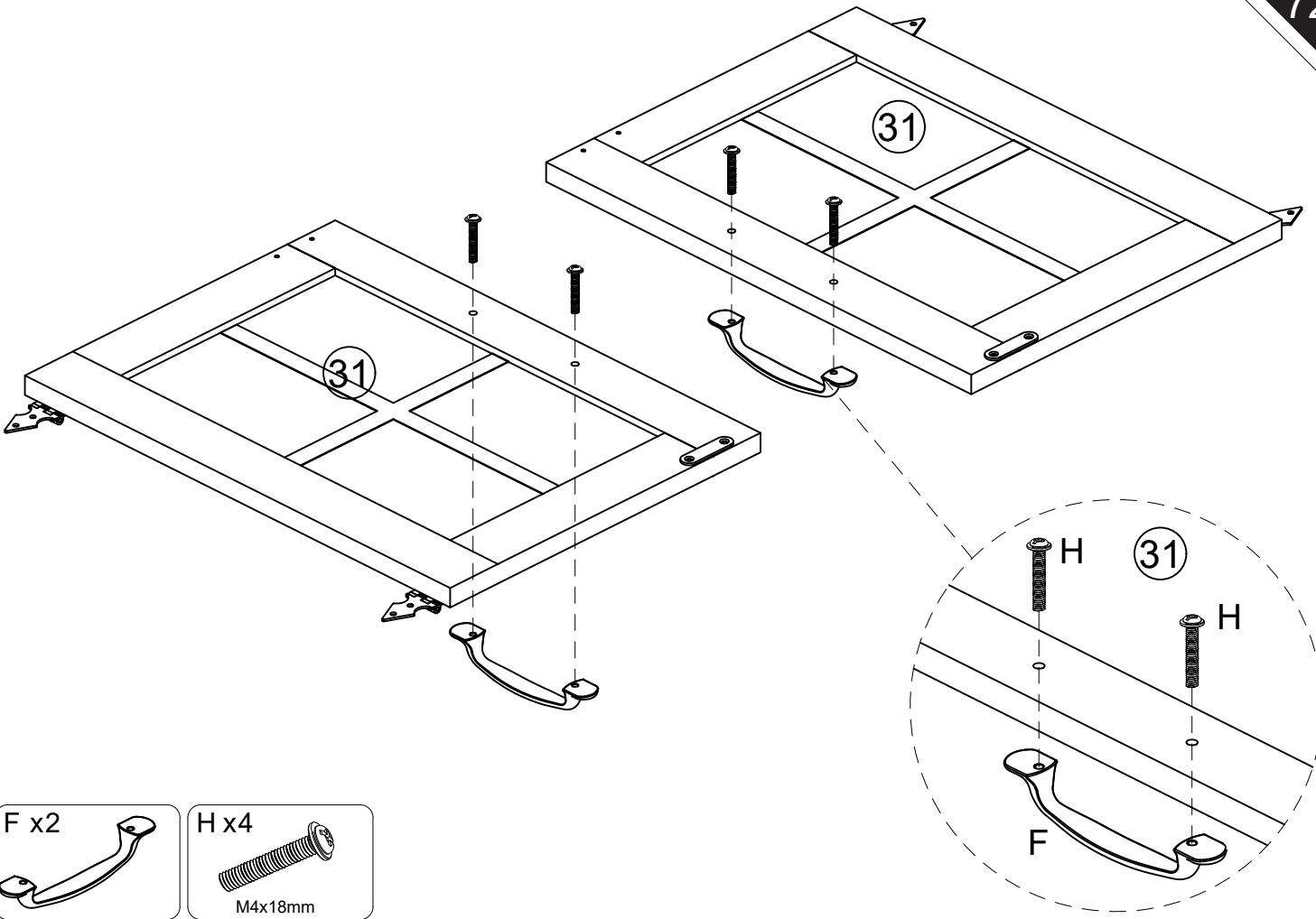

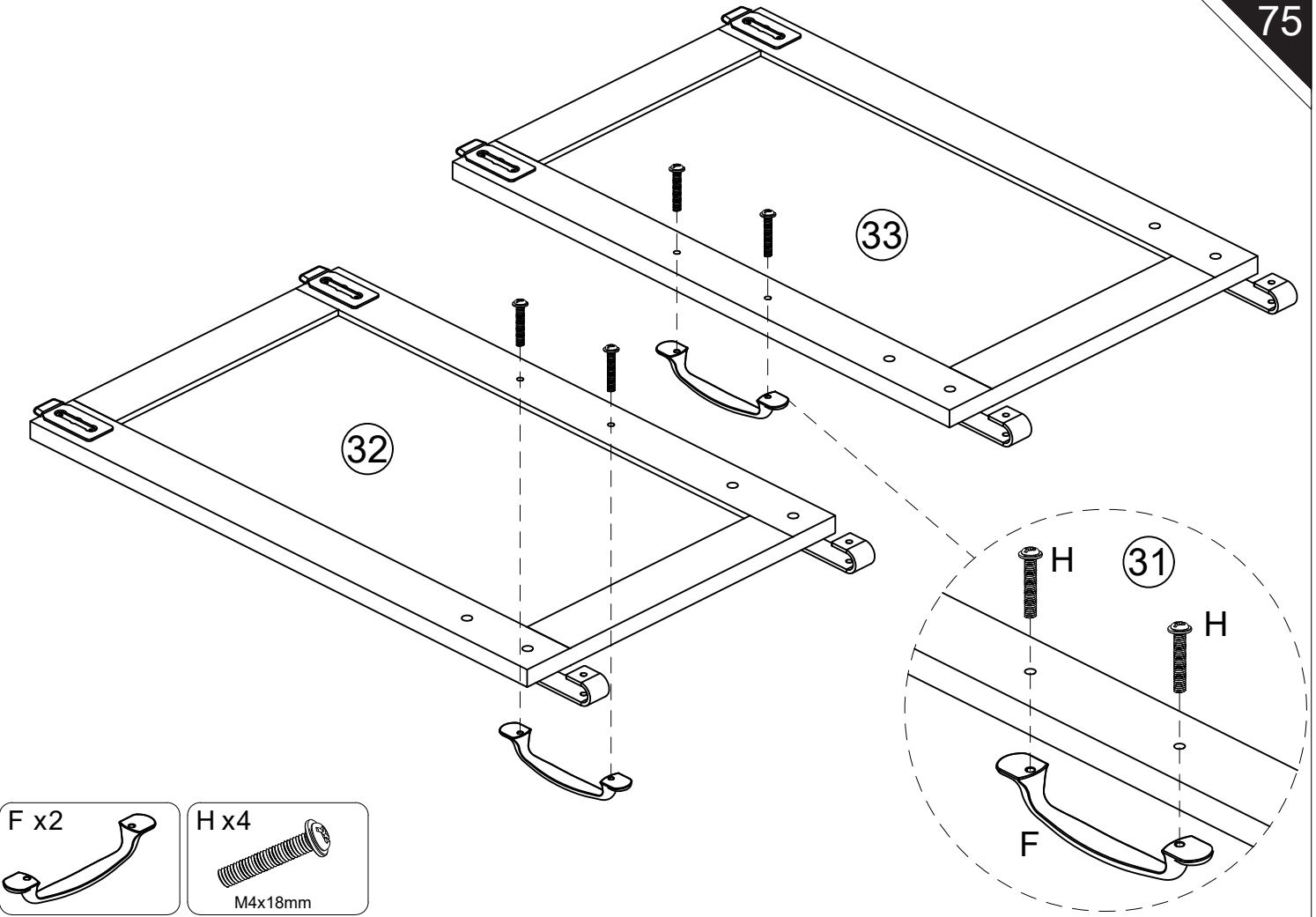
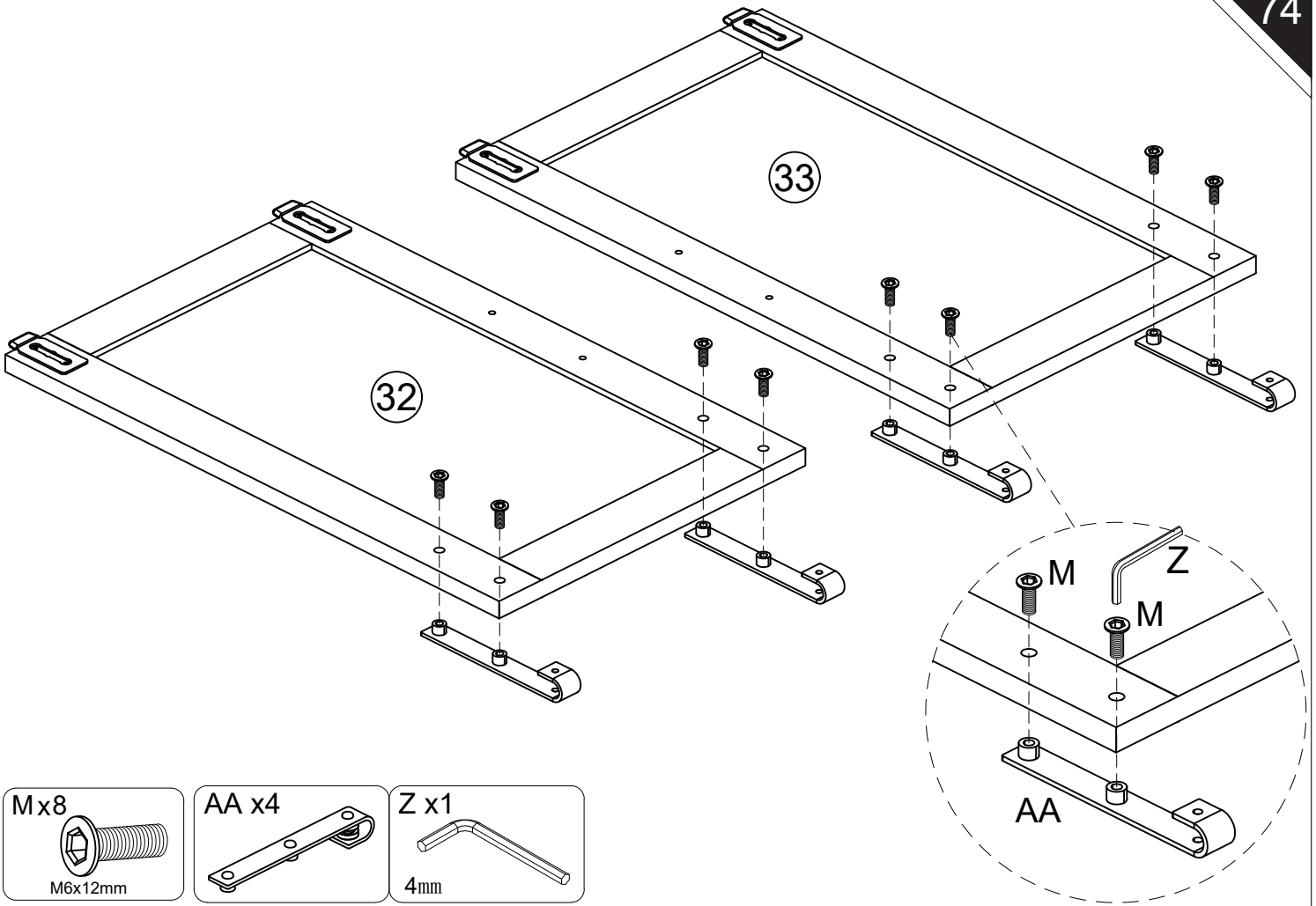

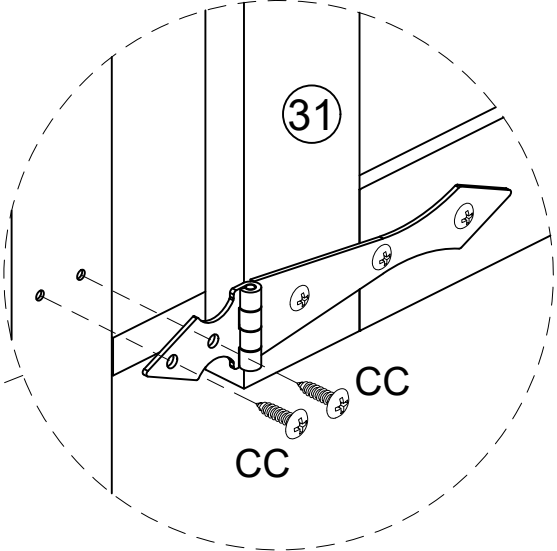
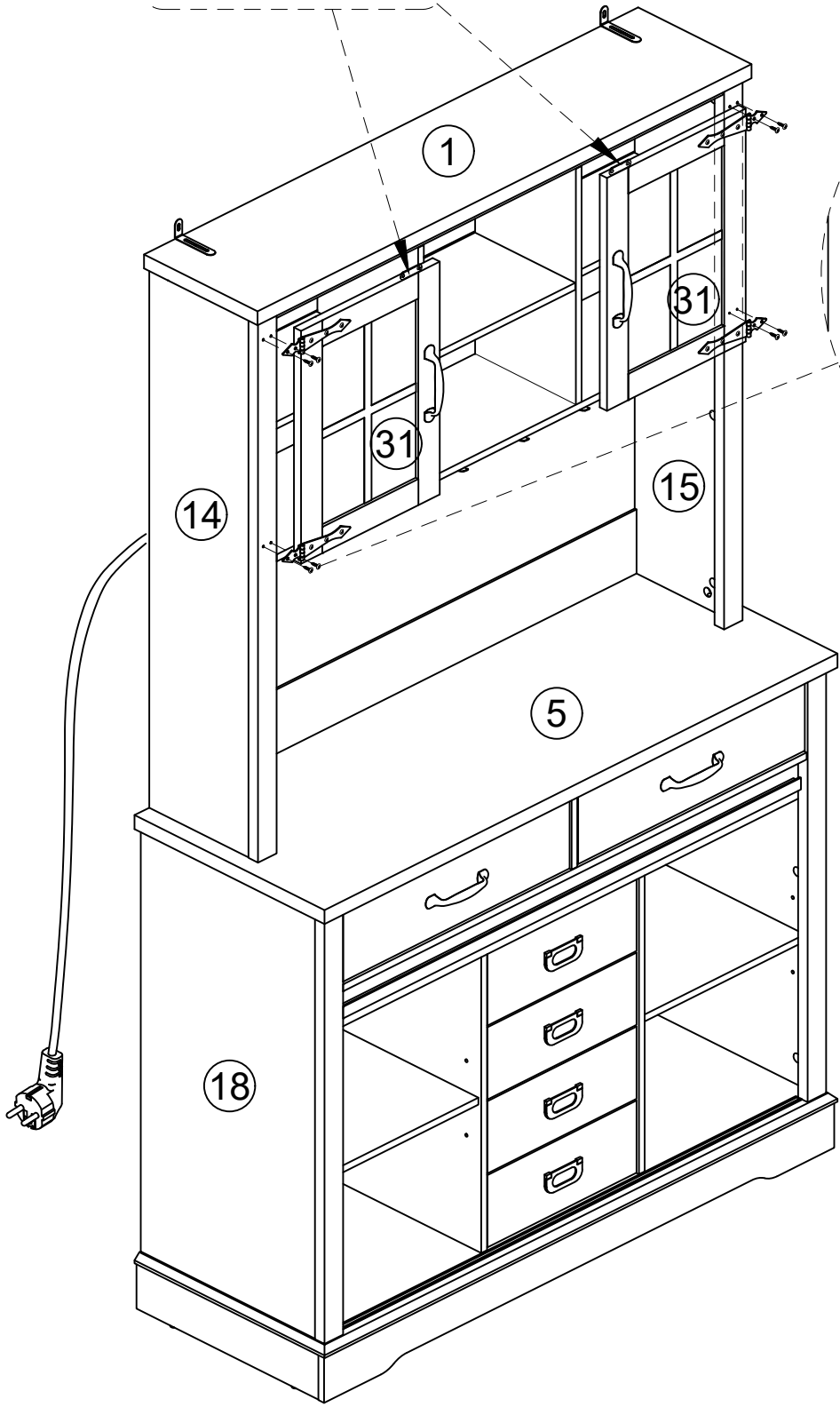

Note that the iron sheet is on the top.

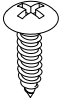

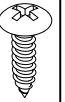
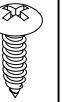
P	Q	V	CC
			
✗	✗	✗	✓
Ø6xØ3x14mm	Ø7xØ3.5x14mm	Ø8xØ4x12mm	Ø8xØ4x14mm

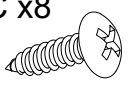
CC x8  
  
Ø8xØ4x14

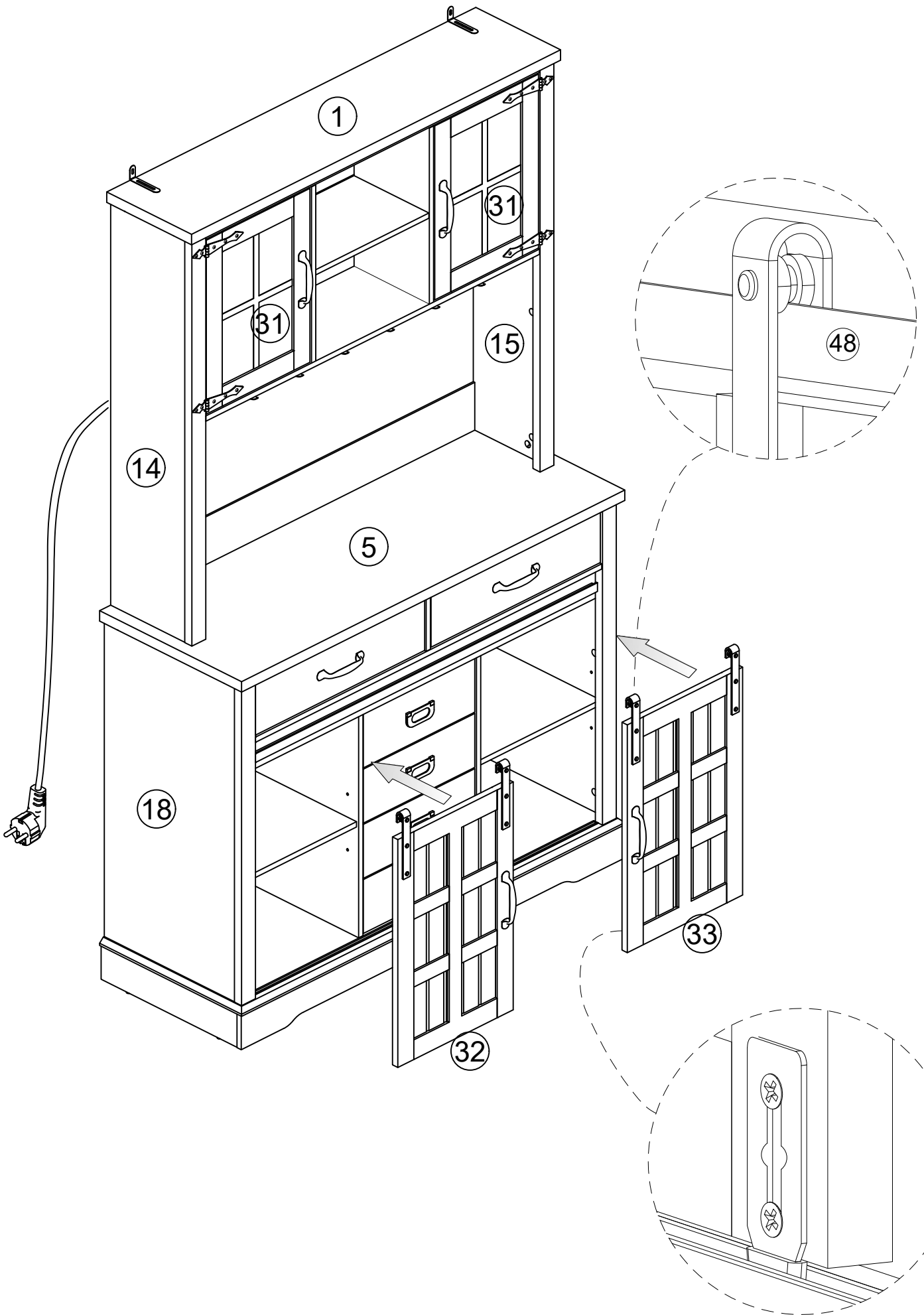

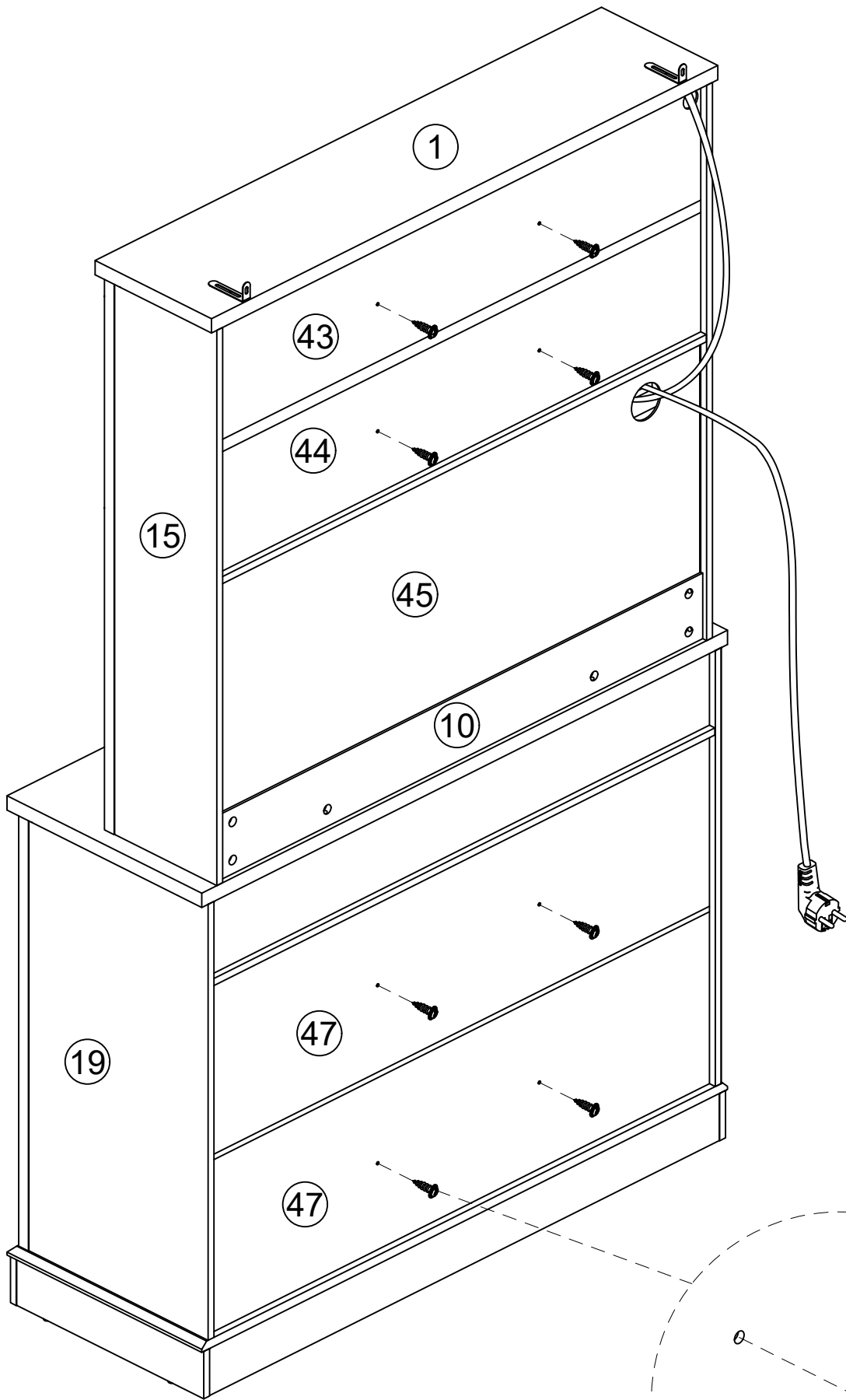

P		Q		V		CC	
X	Ø6xØ3x14mm	✓	Ø7xØ3.5x14mm	X	Ø8xØ4x12mm	X	Ø8xØ4x14mm

Q x8  
  
Ø7xØ3.5x14mm

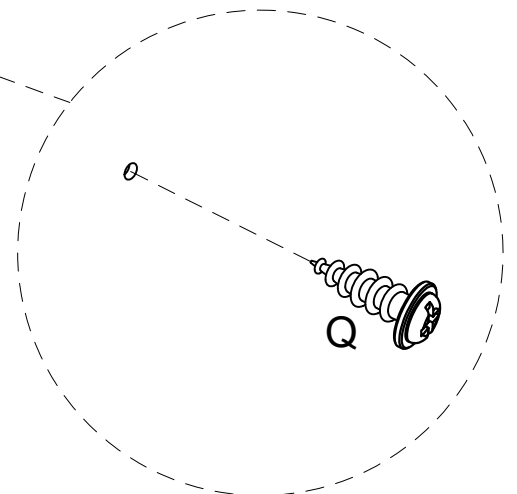

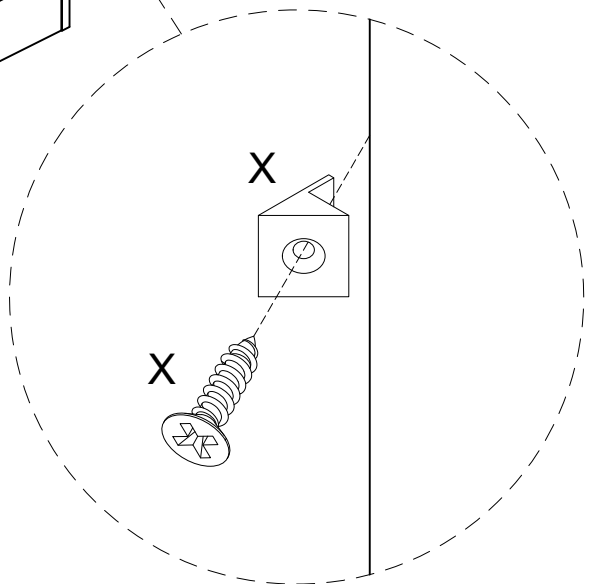
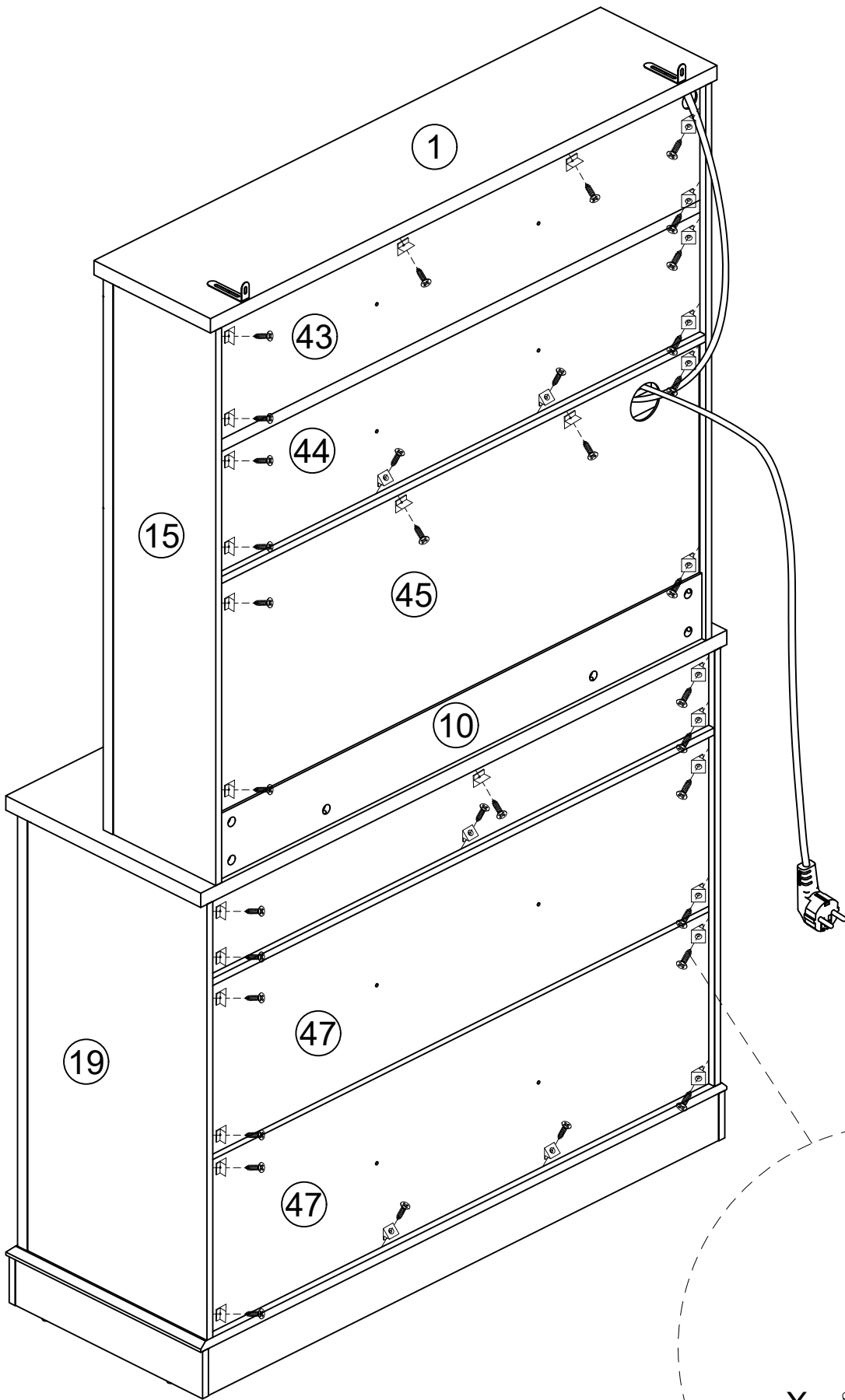

R	S	X
×	×	✓
Ø6xØ3x12mm	Ø7xØ3.5x14mm	Ø6xØ3x16mm

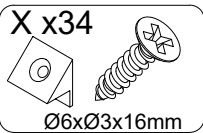

Drill 2 holes on the wall at the required position for anti-falling device installation.

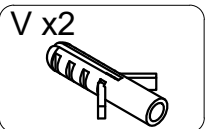
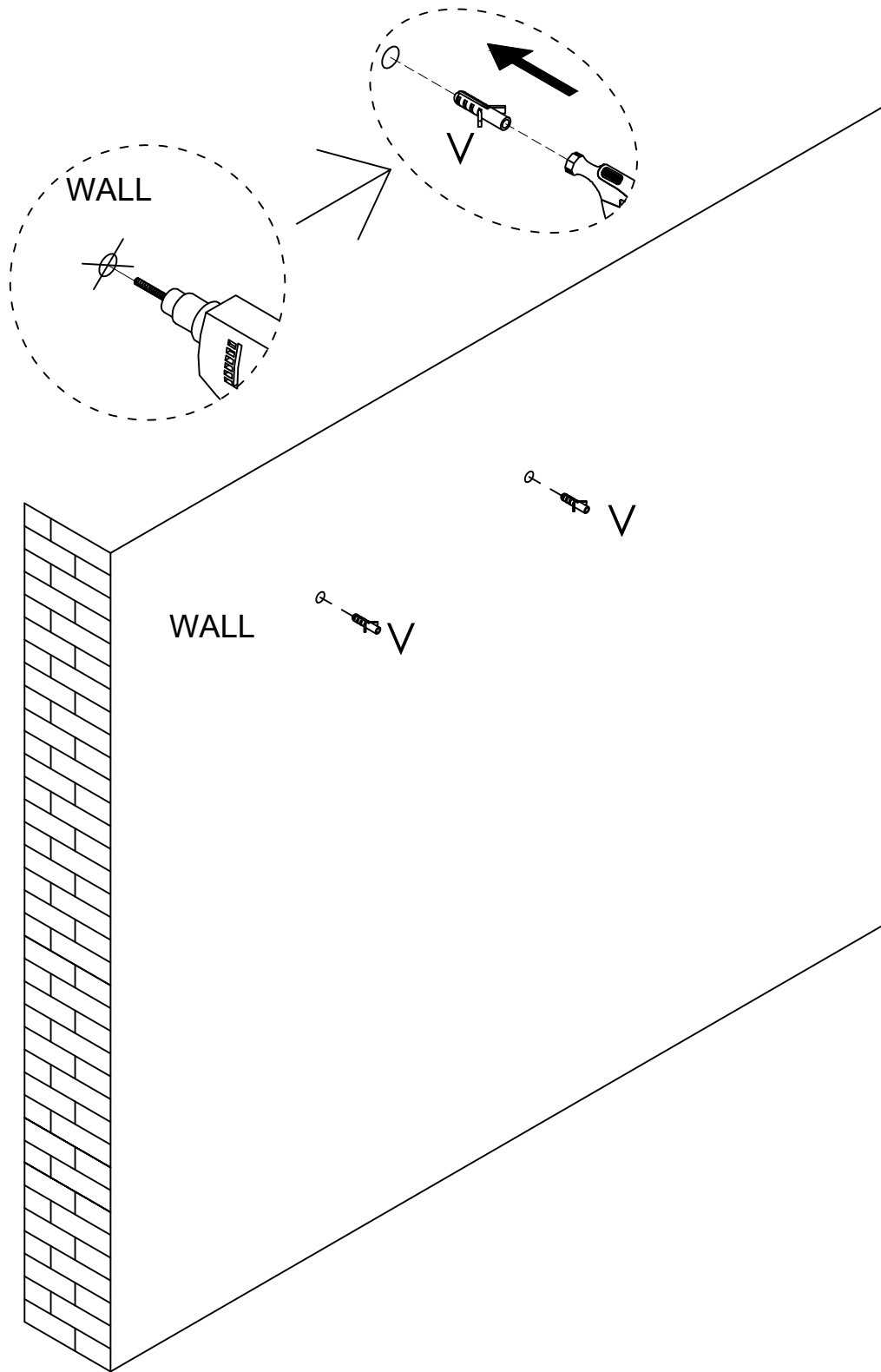

Move the cabinet to the required position, use the V long screw to fix the cabinet to the wall.  
WALL

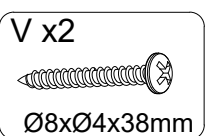
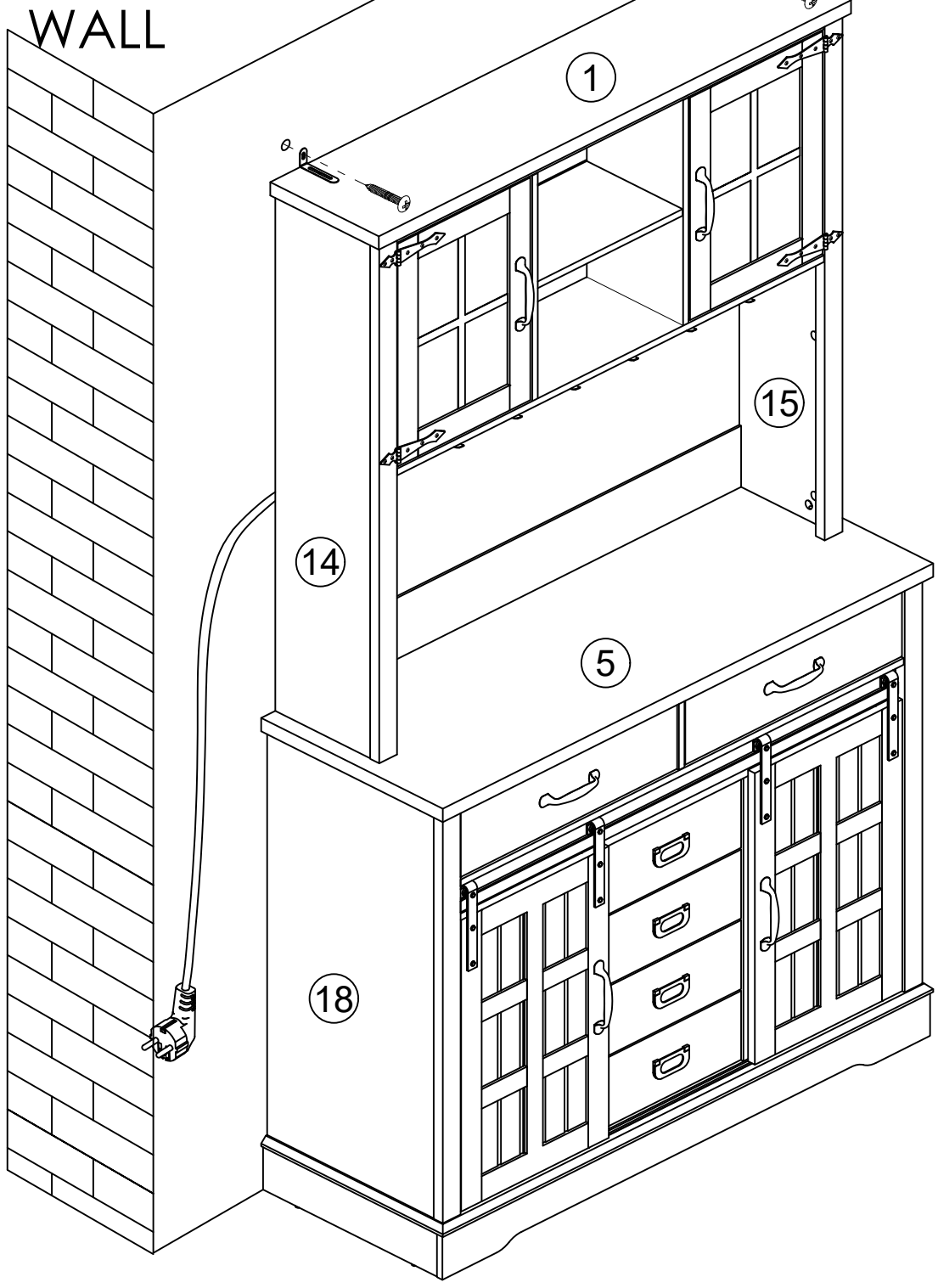
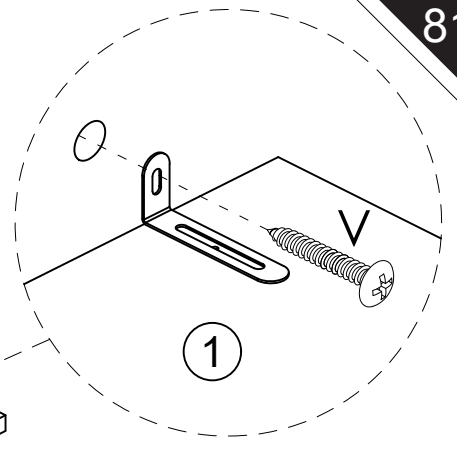

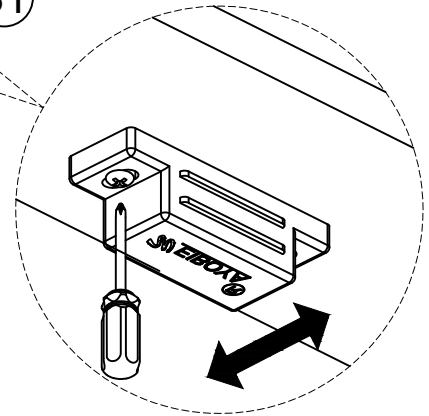
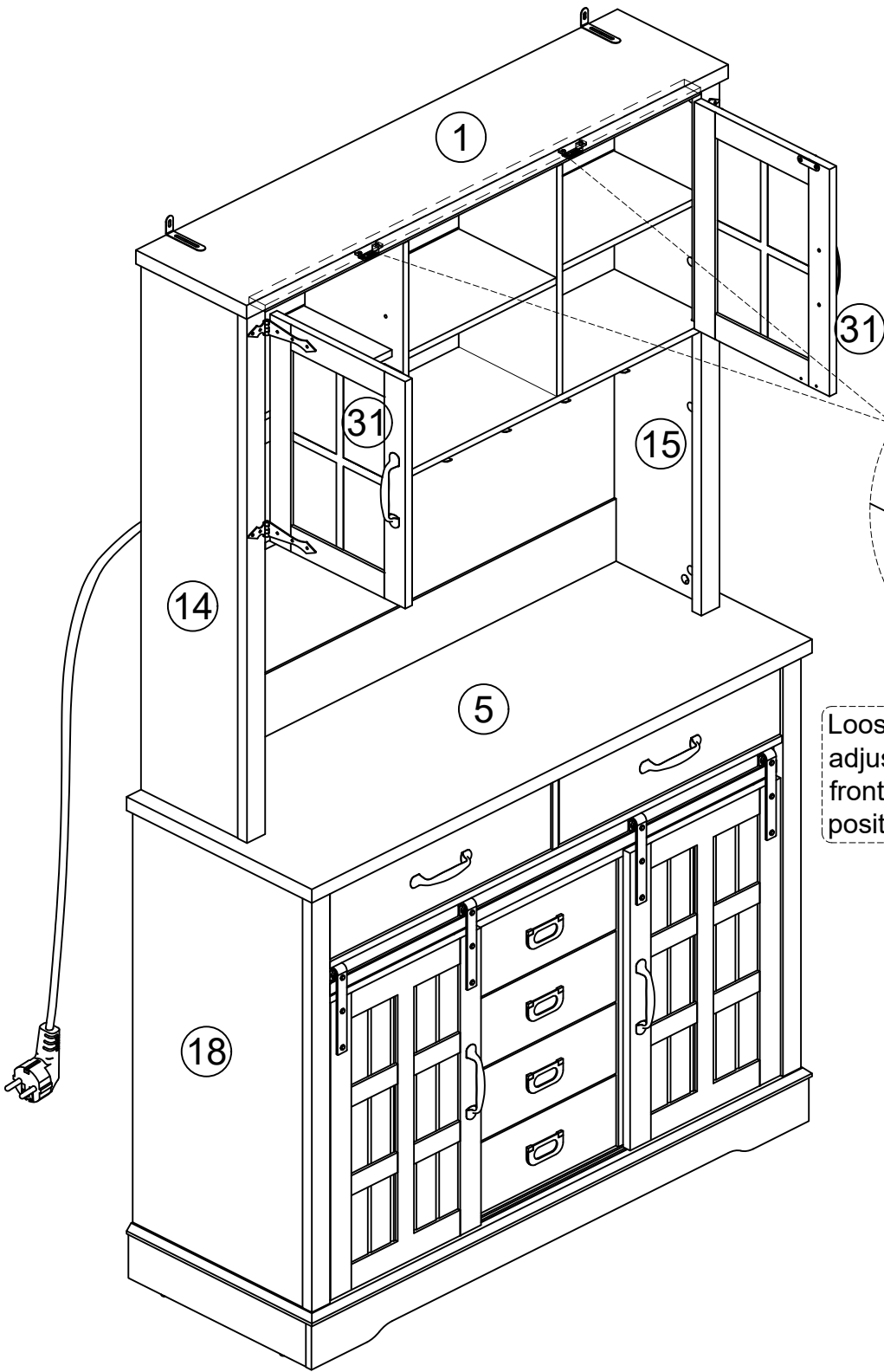

Loosening this screw allows you to adjust the position of the door in the front and back. After adjusting the position, tighten the screw.

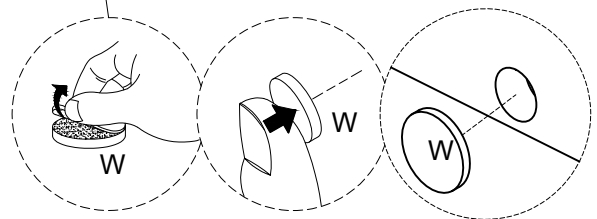
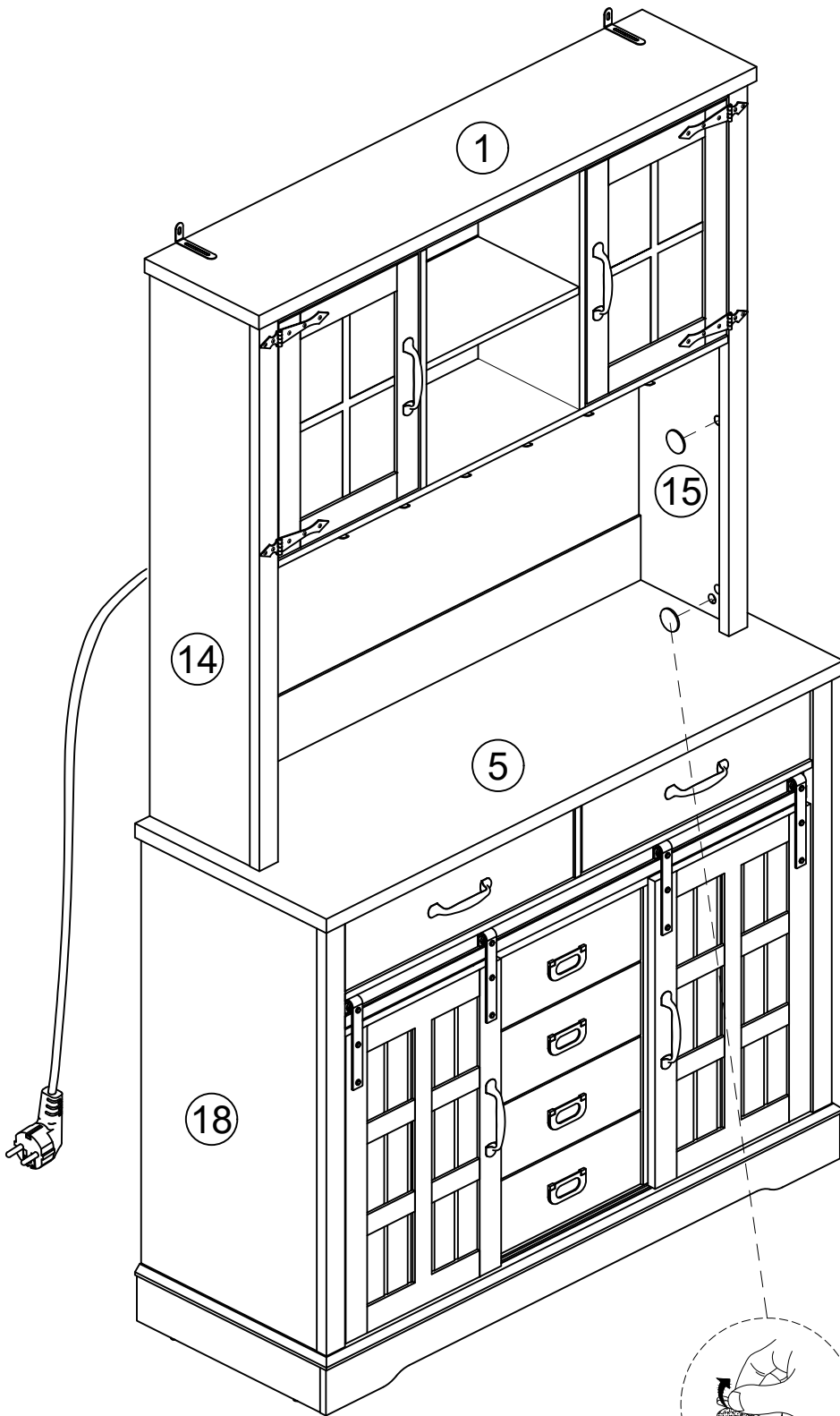

We provide round stickers **W** . You can stick it to cover the exposed nuts or holes so as to look nicer.

W x106

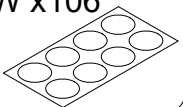

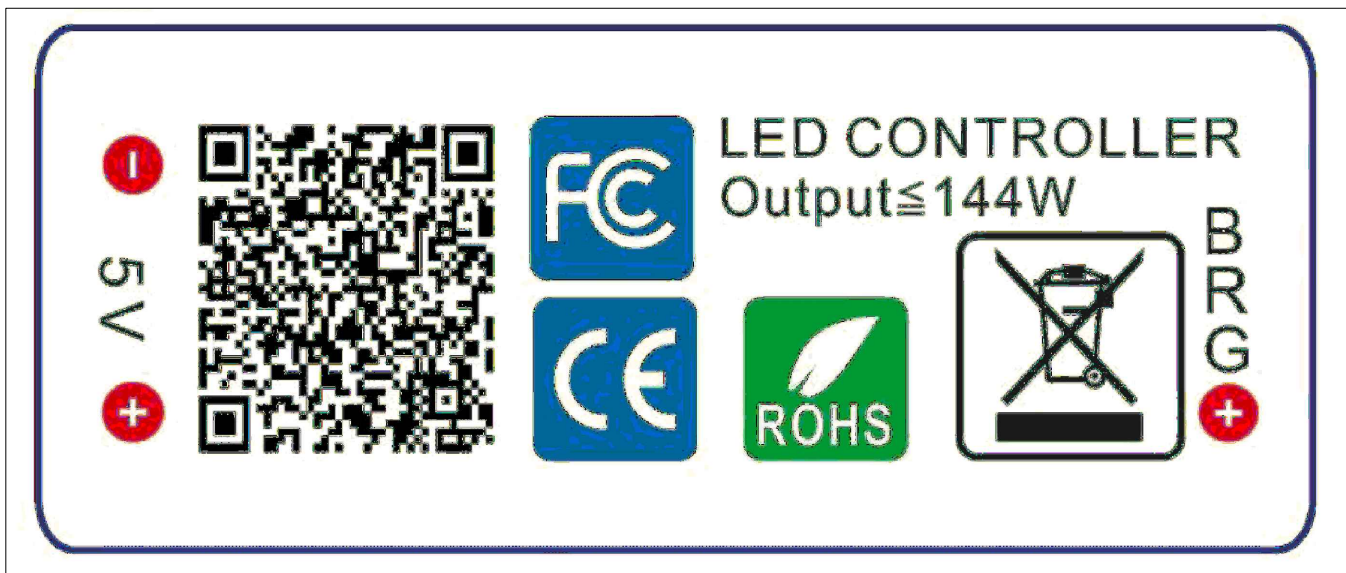

## LotusLantern APP Manual

### 1. Software Overview

#### 1.1 Overview

LotusLantern is a mobile APP to control LED strip by both IOS and Android phones. The traditional control ways like infrared, 433MHz, 2.4GHz and others old wired ways will be replaced by mobile phone control way with convenient, powerful and scalable features.

Through this mobile APP, you can not only control the color, brightness and color temperature of the LED strips but also set up all kinds of fancy flash mode; Also this APP can change the light of the LED strip according to the rhythm of the music. This APP can set and control several LED strips through Bluetooth and the operation is very simple, easy to learn and easy to use.

#### 1.2 Features

- Adjust color LED strips with 60,000 colors to change color and brightness and adjust monochrome LED strips to change brightness and color temperature
- Play music or turn on a sound playback device, you can let the light change the color and brightness with the rhythm of music, the music rhythm beautiful
- Inside multiple setting mode for color change and control LED strips without mobile
- Long distance control with omni-directional antenna, and many-to-many group control mode
- Once the connection is successful, connect automatically next time

#### 1.3 Performance

LotusLantern APP is easy for use as well as great compatible with all kinds of smart phones; After the actual test of hundreds of mobile phones verification, the compatibility is above 95% of mobile phones in the market. APP is small and convenient, it consumes less system resources, so the requirements of the mobile configuration are low. Control delay is small, the operation feels good, light control is smooth with people's visual sense.

### 2. Operating Environment

This APP program requires phones of system above Android 4.3 and iOS 8.0. Mobile phone configuration is not limited.

### 3. Instructions

Note: Android version and iOS version download and use the same method, here in the Android version as an example.

#### 3.1 APP Download

Scan the QR code

iOS and Android systems can download the "LotusLantern" APP by scanning the QR code. Open the browser or other tools with "Scan QR code" function, scan the "LotusLantern" QR code as below:

# Certificate of Compliance

Certificate No.: AiTSZ-250710061RC09

The EUT described above has been consolidated by us and found in compliance with the council RoHS 2.0 Directive(EU)2015/863and(EU)2017/2102 amending Annex I to Directive2011/65/EU.

**Applicant** : Shenzhen Pinchengxin Technology Co., Ltd  
**Address** : 3rd floor, 8 building Yuanling industrial zon, No. 39 Yuanlingcun road, Shiyan street, Bao'an district, Shenzhen  
**Manufacturer** : Shenzhen Pinchengxin Technology Co., Ltd  
**Address** : 3rd floor, 8 building Yuanling industrial zon, No. 39 Yuanlingcun road, Shiyan street, Bao'an district, Shenzhen  
**Product** : 5050 RGB LED Strip Lights with Bluetooth App Controller  
**Model No.** : LED 5050 RGB  
**Trade mark** : N/A  
**Test Report No.** : AiTSZ-250710061R

## Test Standards:

IEC 62321-3-1: 2013  
IEC 62321-4:2013+AMD1:2017 CSV  
IEC 62321-5:2013  
IEC 62321-6:2015  
IEC 62321-7-1:2015  
IEC 62321-7-2:2017  
IEC 62321-8:2017

# RoHS

*Lizhen*

Lizhen

Date: Jul.18, 2025



The statement is based on a single evaluation of one sample of above mentioned products. It does not imply an assessment of the whole production and does not permit the use of the test lab logo.



**Guangdong Asia Hongke Test Technology Co.,Ltd.**

B1/F, Building 11, Junfeng Industrial Park, Chongqing Road, Heping Community, Fuhai Street, Bao'an District, Shenzhen, Guangdong, China

Tel:+86. 0755-23096763

<https://www.aitek.org.cn>

E-mail:info@aitek.org.cn

# CERTIFICATE OF COMPLIANCE

No.: AiTSZ-250710061C-C01

**Product:** 5050 RGB LED Strip Lights with Bluetooth App Controller  
**Trade Mark:** N/A  
**Model:** LED 5050 RGB  
**Applicant:** Shenzhen Pinchengxin Technology Co., Ltd  
**Address:** 3rd floor, 8 building Yuanling industrial zon, No. 39 Yuanlingcun road,Shiyan street, Bao'an district, Shenzhen  
**Manufacture:** Shenzhen Pinchengxin Technology Co., Ltd  
**Address:** 3rd floor, 8 building Yuanling industrial zon, No. 39 Yuanlingcun road,Shiyan street, Bao'an district, Shenzhen

The test sample of product has passed the test according to requirements of the following standards:

Standard(s):	Test report(s) No.:
EN 55032:2015+A11:2020 EN 55035:2017+A11:2020	AiTSZ-250710061CE1

Based on the voluntary assessment of the product sample and technical file, we confirm that the above-mentioned product meets the essential requirements of the Electromagnetic Compatibility (EMC) Directive 2014/30/EU.

The CE mark as show below can be used, under the responsibility of the manufacturer or the importer, after completion of an EC declaration of conformity and follow the CE mark usage rules.



Approved by/Date:

Allen.Wang

Jul. 23, 2025



The statement is based on a single evaluation of one sample of above mentioned products. It does not imply an assessment of the whole production and does not permit the use of the test lab's logo.

## Guangdong Asia Hongke Test Technology Limited

B1/F, Building 11, Junfeng Industrial Park, Chongqing Road, Heping Community, Fuhai Street,  
Bao'an District, Shenzhen, Guangdong, China  
www.aitek.org.cn  
E-mail:info@aitek.org.cn



# CERTIFICATE OF COMPLIANCE

No.: AiTSZ-250710061C-C01

**Product:** 5050 RGB LED Strip Lights with Bluetooth App Controller  
**Trade Mark:** N/A  
**Model:** LED 5050 RGB  
**Applicant:** **Shenzhen Pinchengxin Technology Co., Ltd**  
**Address:** 3rd floor, 8 building Yuanling industrial zon, No. 39 Yuanlingcun road,Shiyan street, Bao'an district, Shenzhen  
**Manufacture:** **Shenzhen Pinchengxin Technology Co., Ltd**  
**Address:** 3rd floor, 8 building Yuanling industrial zon, No. 39 Yuanlingcun road,Shiyan street, Bao'an district, Shenzhen

The test sample of product has passed the test according to requirements of the following standards:

	Standard(s):	Test report(s) No.:
Article 3.1a)	EN IEC 62368-1:2020+A11:2020	AiTSZ-250710061S
	EN 62479: 2010 EN 50663: 2017	AiTSZ-250710061CW3
Article 3.1b)	ETSI EN 301 489-1 V2.2.3 (2019-11) ETSI EN 301 489-17 V3.2.4 (2020-09)	AiTSZ-250710061CW1
Article 3.2)	ETSI EN 300 328 V2.2.2 (2019-07)	AiTSZ-250710061CW2

Based on the voluntary assessment of the product sample and technical file, we confirm that the above-mentioned product meets the essential requirements of the Radio Equipment Directive (RED) 2014/53/EU.

The CE mark as show below can be used, under the responsibility of the manufacturer or the importer, after completion of an EC declaration of conformity and follow the CE mark usage rules.



Approved by/Date:

*Sean She*

July 23, 2025

Sean She



The statement is based on a single evaluation of one sample of above mentioned products. It does not imply an assessment of the whole production and does not permit the use of the test lab's logo.

## Guangdong Asia Hongke Test Technology Limited

B1/F, Building 11, Junfeng Industrial Park, Chongqing Road, Heping Community, Fuhai Street,  
Bao'an District, Shenzhen, Guangdong, China  
www.aitek.org.cn  
E-mail:info@aitek.org.cn





# Certificate of Compliance

RoHS Directive 2011/65/EU appendix II Revised instructions (EU) 2015/863 of the European parliament and of the council on the restriction of the use of certain hazardous substances in electrical and electronic equipment

Issue Date: Nov.27, 2025

Company Name	: GUANG TAI ENTERPRISE CO.,LTD
Address	: Rm402,Bldg 4,No.2 Dapianmei Rd.Dapianmei Village,Dalingshang DONGGUAN GUANGDONG
Manufacturer	: GUANG TAI ENTERPRISE CO.,LTD
Address	: Rm402,Bldg 4,No.2 Dapianmei Rd.Dapianmei Village,Dalingshang DONGGUAN GUANGDONG
Sample Name	: Furniture Power Distribution Unit
Sample Model	: JN02-00-21;JN02-00-111;JN02-00-112;JN02-00-212; JN02-00-22;JN00-00-02K;JN02-00-113K;JN02-00-113; JN02-00-213;JN02-00-23;JN00-00-03K;JN00-00-03; JN00-00-04K;JN00-00-04; JN02-00-23K

This certificate of compliance is based on a test procedure or an evaluation of the above-mentioned product. This is to certify that the above-mentioned product is in compliance with the According to IEC63000:2018+AMD1:2017 and RoHS Directive 2011/65/EU Revised instructions (EU) 2015/863 of the European parliament.

It is only valid in connection with the test report (Report No.: COBO25110736-R1)

# RoHS

Signed for and on Behalf of COBO

Sam Xie / Technical Manager

GUANGDONG TI COBO TESTING CO.,LTD.

EA601,Yishili Building No.9,Zongbu 2nd Road,Songshan Lake Sci.&Tech. Park,Dongguan,Guangdong,China

Tel:86-769-26622263 Fax:86-769-26622012





Product Service

# Attestation of Conformity

No. E8A 128892 0006 Rev. 00

**Holder of Attestation:** **GUANG TAI ENTERPRISE CO., LTD.**

Rm 402, Bldg 4, No.2 Dapianmei Rd.  
Dapianmei Village, Dalingshan  
523000 Dongguan, Guangdong  
PEOPLE'S REPUBLIC OF CHINA

**Name of Object:** **Power supply  
(Furniture Power Distribution Unit)**

**Model(s):** **JN00-00-02K, JN00-00-03K, JN00-00-04K, JN02-00-21,  
JN02-00-22, JN02-00-23, JN02-00-23K, JN02-00-24K,  
JN02-00-24, JN02-00-22M, JN02-00-23M, JN02-00-23KM**

**Description of  
Object:**

Ratings:  
Input: 220-250VAC, 50Hz, Max 16A, Max 3680W  
USB A1/USB A2 Output: 5.0VDC, 2.1A, 10.5W Max  
Total USB output: 5.0VDC, 2.1A, 10.5W Max  
Protection Class: I

**Tested  
according to:**

EN 55032:2015/A1:2020  
EN 55035:2017/A11:2020  
EN IEC 61000-3-2:2019/A1:2021  
EN 61000-3-3:2013/A2:2021

This Attestation of Conformity is issued on a voluntary basis according to the Directive 2014/30/EU relating to electromagnetic compatibility. It confirms that the listed apparatus complies with the principal protection requirements of the directive and is based on the technical specifications applicable at the time of issuance. It refers only to the particular sample submitted for conformity assessment. For details see: [www.tuvsud.com/ps-cert](http://www.tuvsud.com/ps-cert)

**Test report no.:** 657602423101

**Date,** 2025-01-10

( Laurent Yuan )

Page 1 of 1

This Attestation does not replace the regulatory EU Declaration of Conformity (DoC) and does not allow for CE marking. After preparation of the necessary documentation and establishing compliance to requirements of all applicable directives, the manufacturer may sign a DoC and apply the CE marking. The DoC is issued under the sole responsibility of the manufacturer.

TÜV SÜD Product Service GmbH • Ridlerstraße 65 • 80339 Munich • Germany

TÜV®



Product Service

# Attestation of Conformity

No. N8A 128892 0001 Rev. 00

**Holder of Attestation:** **GUANG TAI ENTERPRISE CO., LTD.**

Rm 402, Bldg 4. No.2 Dapianmei Rd.  
Dapianmei Village, Dalingshan  
523000 Dongguan, Guangdong  
PEOPLE'S REPUBLIC OF CHINA

**Product:**

**Cord extension set  
(Furniture Power Distribution Unit)**

This Attestation of Conformity is issued on a voluntary basis according to the Low Voltage Directive 2014/35/EU relating to electrical equipment designed for use within certain voltage limits. It confirms that the listed equipment complies with the principal protection requirements of the directive and is based on the technical specifications applicable at the time of issuance. It refers only to the particular sample submitted for conformity assessment. For details see: [www.tuvsud.com/ps-cert](http://www.tuvsud.com/ps-cert)

**Test report no.:**

6810024020501

**Date,**

2025-01-10

  
( Michael Xu )

Page 1 of 2

This Attestation does not replace the regulatory EU Declaration of Conformity (DoC) and does not allow for CE marking. After preparation of the necessary documentation and establishing compliance to requirements of all applicable directives, the manufacturer may sign a DoC and apply the CE marking. The DoC is issued under the sole responsibility of the manufacturer.

TÜV SÜD Product Service GmbH • Ridlerstraße 65 • 80339 Munich • Germany

TÜV®

ATTESTATION

ATTESTATO

ATESTACIÓN

BESCHEINIGUNG

ATTESTATION



Product Service

# Attestation of Conformity

No. N8A 128892 0001 Rev. 00

**Model(s):** JN00-00-02K, JN00-00-03K, JN00-00-04K,  
JN02-00-21, JN02-00-22, JN02-00-23,  
JN02-00-23K, JN02-00-24K, JN02-00-24,  
JN02-00-22M, JN02-00-23M, JN02-00-23KM

## Parameters:

220-250V~, 50Hz, Max. 16A, Max. 3680W  
USB A1/USB A2 Output: 5.0VDC, 2.1A, 10.5W Max.  
Total USB output: 5.0VDC, 2.1A, 10.5W Max

These models in addition to the naming and some models with connectors, no other difference.

Table 1 model difference:

Model	Difference
JN00-00-02K, JN00-00-03K, JN00-00-04K, JN02-00-21, JN02-00-22, JN02-00-23, JN02-00-23K, JN02-00-24K, JN02-00-24	Without AC connector:
JN02-00-22M, JN02-00-23M, JN02-00-23KM	With AC connector:

## Tested according to:

IEC 60884-1:2002  
IEC 60884-1:2002/AMD1:2006  
IEC 60884-1:2002/AMD2:2013  
IEC 60884-2-7:2011  
IEC 60884-2-7:2011/AMD1:2013  
EN 62368-1:2014/A11:2017

Page 2 of 2

This Attestation does not replace the regulatory EU Declaration of Conformity (DoC) and does not allow for CE marking. After preparation of the necessary documentation and establishing compliance to requirements of all applicable directives, the manufacturer may sign a DoC and apply the CE marking. The DoC is issued under the sole responsibility of the manufacturer.

TÜV SÜD Product Service GmbH • Ridlerstraße 65 • 80339 Munich • Germany

