

DE:Installationsanleitung  
 UK:Installation Instruction  
 FR:Instruction d'installation  
 IT:Istruzioni di installazione  
 ES: Instrucciones de instalación  
 NL: Installatie-instructies  
 SE: Installationsanvisningar  
 PL:Instrukcje instalacji  
 N621P458825

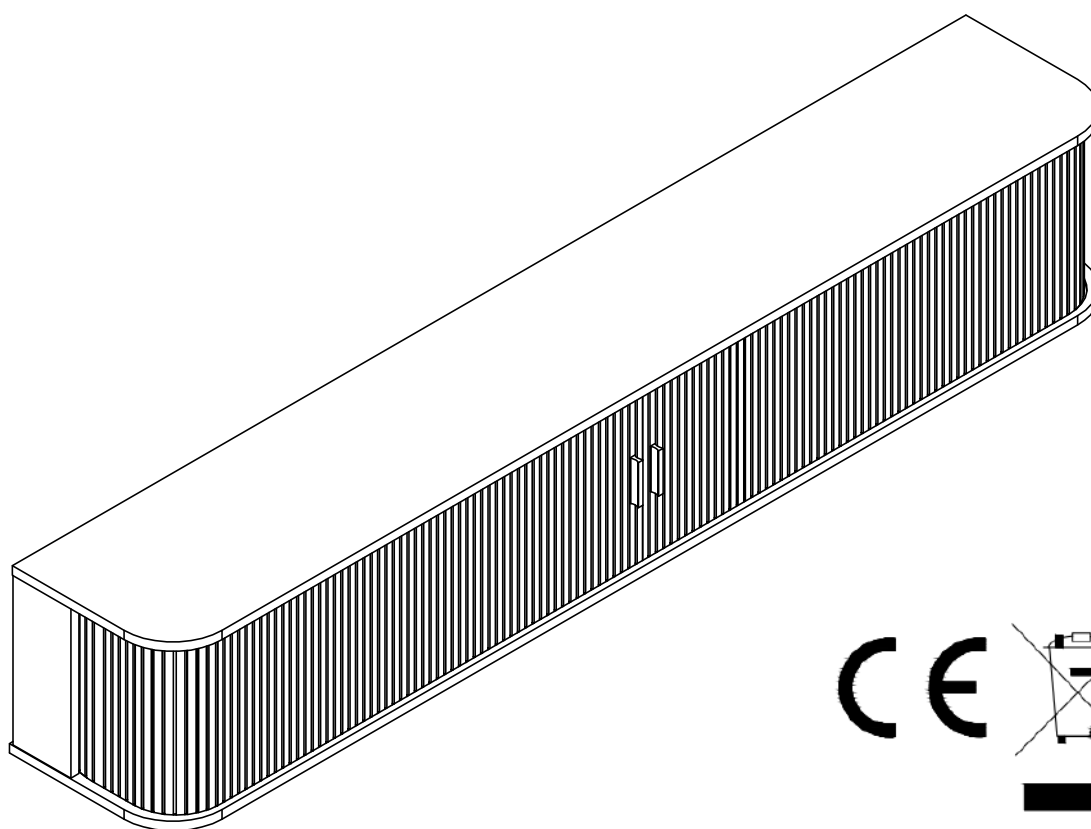

CE



|                |   |
|----------------|---|
| Importeur      | Decobus Handel GmbH   |
| Adresse        | Innungsstraße 9,21244 Buchholz, Deutschland   |
| URL            | <a href="https://www.decobusgroup.de">https://www.decobusgroup.de</a>   |
| Hersteller     | ZHANGZHOU SHUJIAN FURNITURE CO.,LTD   |
| Adresse        | ROOM 101,BUILDING 21,NO.60 BAOXING ROAD,<br>XIANGCHENG DISTRICT,ZHANGZHOU,FUJIAN,CHINA  |
| Email/URL      | Freja_zsj@163.com   |
| Partienummer   | N621P458825   |
| Hergestellt in | CHINA   |
| EC REP         | Decobus Handel GmbH<br>Innungsstraße 9,21244 Buchholz, Deutschland<br><a href="https://www.decobusgroup.de">https://www.decobusgroup.de</a> |



**FR**  
 Cet appareil,  
 ses cordons,  
 et batterie  
 se recyclent

À DÉPOSER  
 EN MAGASIN

À DÉPOSER  
 EN DÉCHÈTERIE

OU

Points de collecte sur [www.quefairedemesdechets.fr](http://www.quefairedemesdechets.fr)  
 Privilégiez la réparation ou le don de votre appareil !

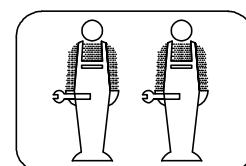

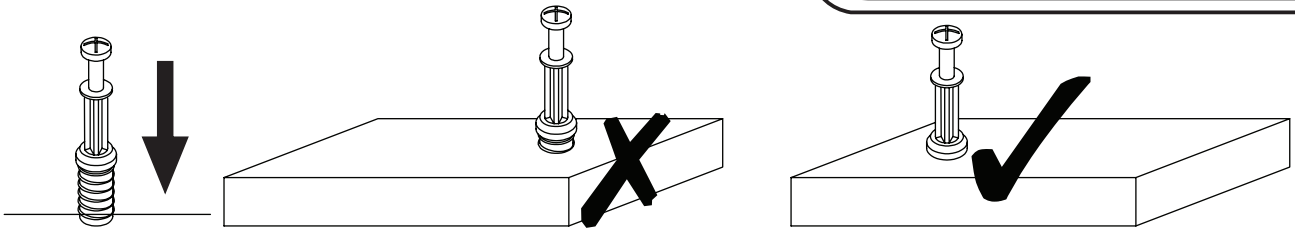

**EN\_QUICKFIT:** Tighten quickfit until shoulder is flush with panel. Do not overtighten or undertighten.

**FR\_RACCORD RAPIDE:** Faites serrer le raccord rapide jusqu'à ce que l'épaulement soit parfaitement encastré dans le panneau. Il ne faut ni trop serrer ni insuffisamment serrer.

**ES\_QUICKFIT:** Apriete quickfit hasta que el hombro se descargue con el panel. NO lo sobreapriete ni lo apriete poco.

**DE\_QUICKFIT:** Ziehen Sie den Quickfit fest, bis die Schulter mit der Platte bündig ist. Bitte nicht zu fest oder zu schwach anziehen.

**IT\_MONTAGGIO RAPIDO:** Stringere il montaggio rapido fino a quando la spalla è a filo con il pannello, non stringere troppo o troppo poco.

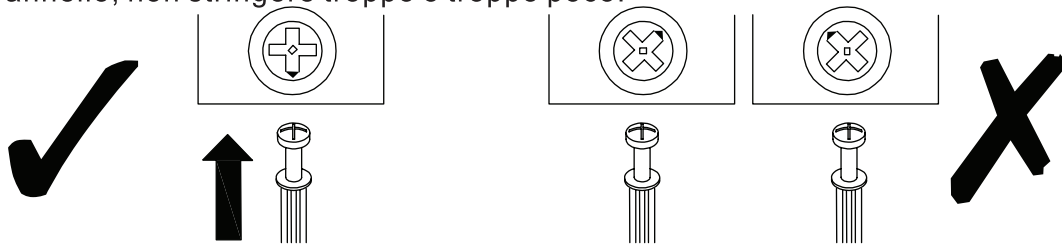

**EN\_CAM LOCK:** When fitting cam lock, ensure starting position is correct before you insert connecting quickfit.

**FR\_SERRURE BATTEUSE:** Avant d'insérer la serrure batteuse, veillez à la bonne orientation avant d'insérer le raccord rapide.

**ES\_CIERRE DE LA CÁMARA:** Cuando instale el cierre de la cámara, asegúrese de que la posición de inicio es correcta antes de que inserte el quickfit conector.

**DE\_CAM-LOCK:** Achten Sie bei der Montage des Cam-Locks auf die richtige Ausgangsposition, bevor Sie den Quickfit einsetzen.

**IT\_BLOCCAGGIO A CAMMA:** Quando si monta il bloccaggio a camma, assicurarsi che la posizione iniziale sia corretta prima di inserire il montaggio rapido di collegamento.

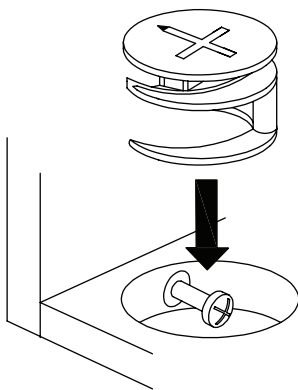

**EN\_Quickfit head** should be in the centre of the cam lock when the two panels are joined.

Cam lock should be inserted before quickfit.

**FR\_Lorsque** les deux panneaux sont assemblés, la tête du raccord rapide doit reposer au centre de la serrure batteuse. Il faut insérer la serrure batteuse avant le raccord rapide.

**ES\_El** cabezal del quickfit debe estar en el centro del cierre de la cámara cuando se unan los dos paneles.

Se debe insertar el cierre de la cámara antes que el quickfit.

**DE\_Der** Quickfit-Kopf sollte sich in der Mitte des Cam-Locks befinden, wenn die beiden Platten zusammengefügt sind. Der Cam-Lock sollte vor dem Quickfit eingesetzt werden.

**IT\_La** testa del montaggio rapido deve trovarsi al centro del bloccaggio a camma quando i due pannelli sono uniti.

Il Bloccaggio a Camma deve essere inserito prima del montaggio rapido.

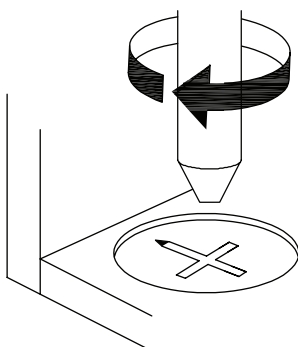

**EN\_Turn** cam lock clockwise to tighten.

**FR\_Faites** tourner la serrure batteuse dans le sens des aiguilles d'une montre pour la resserrer.

**ES\_Gire** el cierre de la cámara en sentido horario para apretarlo.

**DE\_Drehen** Sie den Cam-Lock im Uhrzeigersinn, um ihn festzuziehen.

**IT\_Ruotare** il bloccaggio a camma in senso orario per stringere.

DE:Vor dem Einbau die Schrauben in die Löcher stecken und festziehen, aber nicht bis 100%, 70% bis 80% anziehen reicht aus. Schließlich, nachdem alle Schrauben installiert sind, ziehen Sie alle Schrauben auf 100%. Wenn Sie auf diese Probleme stoßen, wie z. B. Fehlausrichtung der Löcher oder Unfähigkeit, bestimmte Teile zu installieren, überprüfen Sie bitte, ob die Schrauben korrekt verwendet werden und passen Sie die Dichtigkeit der Schrauben an.

UK:Before installation, insert the screws into the holes and tighten them, but do not tighten them to 100%, 70% to 80% is sufficient. Finally, after all screws are installed, tighten all screws to 100%. If you encounter these issues, such as if the holes cannot be aligned or some parts cannot be installed, please check if the screws are used correctly and adjust the tightness of the screws.

FR:Insérer la vis dans le trou avant la fin de l'assemblage, serrer la vis, mais ne pas serrer à 100%, 70% ~ 80% est correct. Enfin, une fois que toutes les vis sont bien serrées, toutes les vis sont serrées à 100%. Si vous rencontrez ces problèmes, par exemple si les trous ne sont pas alignés ou si certaines pièces ne peuvent pas être montées, vérifiez que les vis sont utilisées correctement et ajustez leur serrage.

IT:Prima dell'installazione, inserire le viti nei fori e stringerle, ma non al 100%, è sufficiente stringerle al 70% - 80%. Infine, dopo aver installato tutte le viti, stringere tutte le viti al 100%. Se riscontri problemi come disallineamenti dei fori o difficoltà nell'installare alcuni componenti, verifica che le viti siano utilizzate correttamente e regola la tensione delle viti.

ES:Antes de la instalación, coloque los tornillos en los agujeros y apriételes, pero no al 100%; apretar al 70% - 80% es suficiente. Finalmente, después de haber instalado todos los tornillos, apriete todos los tornillos al 100%. Si se encuentra con problemas como desalineación de los agujeros o dificultad para instalar ciertas piezas, verifique que los tornillos se estén utilizando correctamente y ajuste la tensión de los tornillos.

NL:Voordat u begint met de installatie, plaatst u de schroeven in de gaten en draait u ze aan, maar draai ze niet volledig aan; 70% tot 80% is voldoende. Draai uiteindelijk, nadat alle schroeven zijn geplaatst, alle schroeven volledig aan. Als u problemen ondervindt, zoals niet uitgelijnde gaten of onderdelen die niet kunnen worden geïnstalleerd, controleer dan of de schroeven correct zijn gebruikt en pas de spanning van de schroeven aan.

SE:Innan installation, sätt i skruvarna i hålen och dra åt dem, men dra inte åt dem helt; 70% till 80% är tillräckligt. Slutligen, när alla skruvar är installerade, dra åt alla skruvar helt. Om du stöter på problem, som att hålen inte kan justeras eller vissa delar inte kan installeras, kontrollera om skruvarna används korrekt och justera skruvarnas åtdragning.

PL:Przed instalacją wstaw śruby w otwory i dokręć je, ale nie dokręcaj ich na 100%; 70% do 80% wystarczy. Na koniec, po zainstalowaniu wszystkich śrub, dokręć wszystkie śruby do 100%. Jeśli napotkasz problemy, takie jak niedopasowane otwory lub części, które nie mogą być zainstalowane, sprawdź, czy śruby są używane prawidłowo i dostosuj ich dokręcenie.

**(DE):**

1. Die maximale Tragfähigkeit des Produkts beträgt 60 kg, bitte nicht überladen.
2. Lassen Sie Kinder nicht auf Möbel klettern, da dies Umkippen und schwere Verletzungen verursachen kann.
3. Um die Sicherheit zu gewährleisten, installieren Sie bitte gemäß der Anleitung und ziehen Sie bei Bedarf Fachleute zurate.
4. Stellen Sie Möbel nicht in die Nähe von Feuerquellen oder heißen Gegenständen, um das Brandrisiko zu vermeiden.
5. Stellen Sie Möbel nicht in feuchten Umgebungen auf, um Materialschäden zu verhindern.
6. Überprüfen Sie regelmäßig alle Verbindungen und Befestigungen, um sicherzustellen, dass sie fest sind, um Unfälle zu vermeiden.
7. Reinigen Sie Möbel mit einem feuchten Tuch oder Alkohol, vermeiden Sie die Verwendung von reinigenden Mitteln mit ätzenden Chemikalien.

**(UK):**

1. The maximum weight capacity of the product is 60kg; do not overload.
2. Do not allow children to climb on furniture, as it may cause tipping and serious injury.
3. For safety, please install correctly according to the instructions, and seek professional assistance if necessary.
4. Do not place furniture near fire sources or hot items to avoid fire risk.
5. Do not place furniture in damp environments to prevent material damage.
6. Regularly check all connections and fasteners to ensure they are secure to prevent accidents.
7. Clean furniture with a damp cloth or alcohol; avoid using cleaners with corrosive chemicals.

**(FR):**

1. La capacité maximale de charge du produit est de 60 kg, ne pas surcharger.
2. Ne laissez pas les enfants grimper sur les meubles, cela peut entraîner un basculement et des blessures graves.
3. Pour garantir la sécurité, veuillez installer correctement selon les instructions et demander de l'aide à des professionnels si nécessaire.
4. Ne placez pas les meubles près de sources de chaleur ou d'objets chauds pour éviter les risques d'incendie.
5. Ne placez pas les meubles dans des environnements humides pour éviter d'endommager les matériaux.
6. Vérifiez régulièrement tous les raccords et fixations pour vous assurer qu'ils sont sécurisés afin d'éviter les accidents.
7. Nettoyez les meubles avec un chiffon humide ou de l'alcool, évitez d'utiliser des nettoyants contenant des produits chimiques corrosifs.

**(IT):**

1. La capacità massima del prodotto è di 60 kg, non sovraccaricare.
2. Non permettere ai bambini di arrampicarsi sui mobili, poiché ciò potrebbe causare ribaltamenti e gravi infortuni.
3. Per garantire la sicurezza, installare correttamente secondo le istruzioni e chiedere assistenza a professionisti se necessario.
4. Non posizionare i mobili vicino a fonti di calore o oggetti caldi per evitare rischi di incendio.
5. Non posizionare i mobili in ambienti umidi per prevenire danni ai materiali.
6. Controllare regolarmente tutte le connessioni e le viti per assicurarsi che siano sicure e prevenire incidenti.
7. Pulire i mobili con un panno umido o alcol; evitare di utilizzare detersivi contenenti sostanze chimiche corrosive.

**(ES):**

1. La capacidad máxima del producto es de 60 kg, no sobrecargar.
2. No permita que los niños escalen los muebles, ya que puede provocar vuelcos y lesiones graves.
3. Para garantizar la seguridad, instale correctamente según las instrucciones y busque asistencia profesional si es necesario.
4. No coloque muebles cerca de fuentes de fuego u objetos calientes para evitar riesgos de incendio.
5. No coloque muebles en ambientes húmedos para evitar daños en los materiales.
6. Revise regularmente todas las conexiones y sujetadores para asegurarse de que estén firmes y prevenir accidentes.
7. Limpie los muebles con un paño húmedo o alcohol; evite usar limpiadores con productos químicos corrosivos.

**(NL):**

1. De maximale draagcapaciteit van het product is 60 kg; niet overbelasten.
2. Laat kinderen niet op meubels klimmen, dit kan omvallen en ernstige verwondingen veroorzaken.
3. Installeer correct volgens de instructies voor de veiligheid en vraag indien nodig om professionele hulp.
4. Plaats meubels niet in de buurt van vuurbronnen of hete voorwerpen om brandrisico te voorkomen.
5. Plaats meubels niet in vochtige omgevingen om materiaalschade te voorkomen.
6. Controleer regelmatig alle verbindingen en bevestigingen om ervoor te zorgen dat ze stevig zijn en ongelukken te voorkomen.
7. Maak meubels schoon met een vochtige doek of alcohol; vermijd het gebruik van schoonmaakmiddelen met bijtende chemicaliën.

**(SE):**



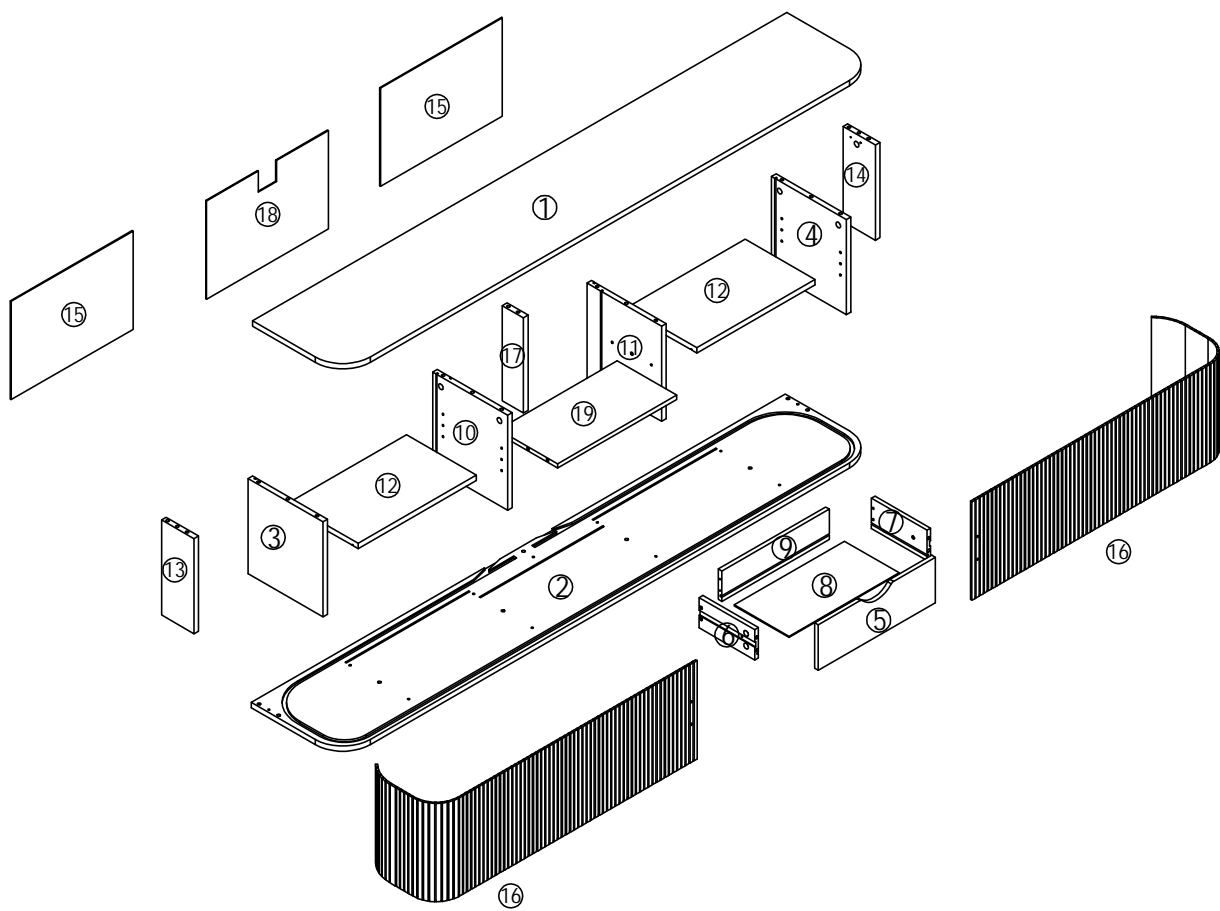

1. Den maximala belastningen för produkten är 60 kg; överbelasta inte.
2. Låt inte barn klättra på möbler, eftersom det kan leda till att de tippar och orsakar allvarliga skador.
3. För att säkerställa säkerheten, installera korrekt enligt instruktionerna och be om professionell hjälp vid behov.
4. Placera inte möbler nära värmekällor eller heta föremål för att undvika brandrisk.
5. Placera inte möbler i fuktiga miljöer för att förhindra materialskador.
6. Kontrollera regelbundet alla anslutningar och fästen för att säkerställa att de är säkra för att förhindra olyckor.
7. Rengör möbler med en fuktig trasa eller alkohol; undvik att använda rengöringsmedel med frätande kemikalier.

**(PL):**

1. Maksymalne obciążenie produktu wynosi 60 kg; nie przeciążaj.
2. Nie pozwalaj dzieciom wspinać się na meble, ponieważ może to prowadzić do przewrócenia i poważnych obrażeń.
3. Aby zapewnić bezpieczeństwo, zainstaluj poprawnie zgodnie z instrukcjami i w razie potrzeby skorzystaj z pomocy specjalistów.
4. Nie stawiaj mebli w pobliżu źródeł ognia lub gorących przedmiotów, aby uniknąć ryzyka pożaru.
5. Nie umieszczaj mebli w wilgotnym środowisku, aby zapobiec uszkodzeniu materiałów.
6. Regularnie sprawdzaj wszystkie połączenia i mocowania, aby upewnić się, że są solidne, aby zapobiec wypadkom.
7. Czyść meble wilgotną szmatką lub alkoholem; unikaj używania środków czyszczących z żrącymi chemikaliami.

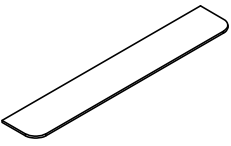
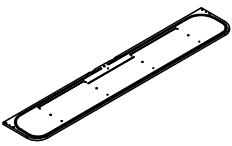
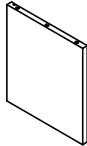
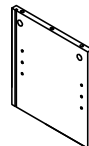
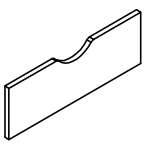
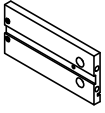
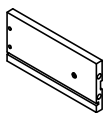
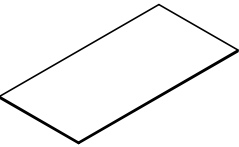
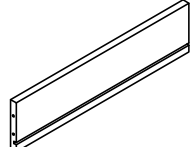
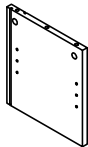
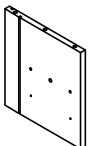
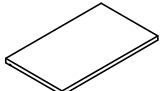

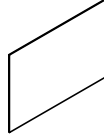

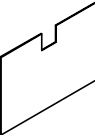
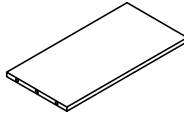





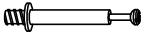

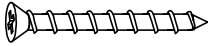
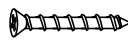





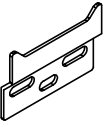
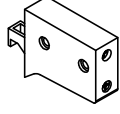

# N621P458825

|   |   |   |   |   |
|---|---|---|---|---|
|  |  |  |   |  |
| ① x1pc  | ② x1pc  | ③ x1pc  | ④ x1pc  | ⑤ x1pc  |
|  |  |  |   |  |
| ⑥ x1pc  | ⑦ x1pc  | ⑧ x1pc  | ⑨ x1pc  | ⑩ x1pc  |
|  |  |  |  |  |
| ⑪ x1pc  | ⑫ x2pcs   | ⑬ x1pc  | ⑭ x1pc  | ⑮ x2pcs   |
|  |  |  |   |   |
| ⑯ x2pcs   | ⑰ x1pc  | ⑱ x1pc  | ⑲ x1pc  |   |

Hardware List  
Hardwareliste

N621P458825

|  |  |  |   |   |
|--|--|--|---|---|
| <br>Ø6x35mm<br>A)x19pcs | <br>Ø15x9mm<br>B)x19pcs | <br>Ø8x30mm<br>C)x20pcs | <br>Ø4x40mm<br>D)x21pcs | <br>Ø4x30mm<br>E)x6pcs |
| <br>F)x2pcs             | <br>G)x1pc              | <br>M3x14mm<br>H)x16pcs | <br>M4x8mm<br>I)x4pcs  | <br>J)x12pcs           |
| <br>K)x3pcs             | <br>L)x3pcs             | <br>M)x3pcs             | <br>N)x2pcs             | <br>O)x19pcs           |
| <br>P)x8pcs             | <br>Q)x6pcs             | <br>R)x1pc              | <br>M4x10mm<br>S)x2pcs |   |

|   |   |
|---|---|
|  |  |
| M3.5x4mm  | M4x30mm   |
| ⓓ x21pcs  | ⓔ x6pcs   |

DE: Bitte beachten Sie, dass die Formen der Schrauben D und E ähnlich sind. Bitte installieren Sie entsprechend der Anleitung und unterscheiden Sie sie!

UK: Please note that the shapes of screws D and E are similar. Please install according to the instructions and distinguish them!

FR: Notez que les vis D et E ont des formes similaires. Veuillez les installer en suivant les instructions pour les séparer!



IT: Si prega di notare che le forme delle viti D e E sono simili. Si prega di installarle seguendo le istruzioni e di distinguerle!

ES: Por favor, tenga en cuenta que las formas de los tornillos D y E son similares. Por favor, instálelos de acuerdo con las instrucciones y distíngalos.

NL: Let op, de vormen van schroeven D en E zijn vergelijkbaar. Installeer volgens de instructies en maak onderscheid tussen ze!

SE: Observera att formerna på skruvarna D och E är lika. Installera enligt anvisningarna och särskilj dem!

PL: Zauważ, że kształty śrub D i E są podobne. Zainstaluj zgodnie z instrukcjami i rozróżnij je!

|   |  |
|---|--|
| <br>M4x8mm | <br>M4x10mm |
| ①x4pcs  | ②x2pcs   |

DE: Bitte beachten Sie, dass die Formen der Schrauben I und S ähnlich sind. Bitte installieren Sie entsprechend der Anleitung und unterscheiden Sie sie!

UK: Please note that the shapes of screws I and S are similar. Please install according to the instructions and distinguish them!

FR: Notez que les vis I et S ont des formes similaires. Veuillez les installer en suivant les instructions pour les séparer!

IT: Si prega di notare che le forme delle viti I e S sono simili. Si prega di installarle seguendo le istruzioni e di distinguerle!

ES: Por favor, tenga en cuenta que las formas de los tornillos I y S son similares. Por favor, instálelos de acuerdo con las instrucciones y distíngalos.

NL: Let op, de vormen van schroeven I en S zijn vergelijkbaar. Installeer volgens de instructies en maak onderscheid tussen ze!

SE: Observera att formerna på skruvarna I och S är lika. Installera enligt anvisningarna och särskilj dem!

PL: Zauważ, że kształty śrub I i S są podobne. Zainstaluj zgodnie z instrukcjami i rozróżnij je!

1

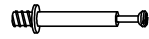

Ø6x35mm

Ⓐx2pcs



M3x14mm

Ⓗx2pcs



Ⓔx1pc

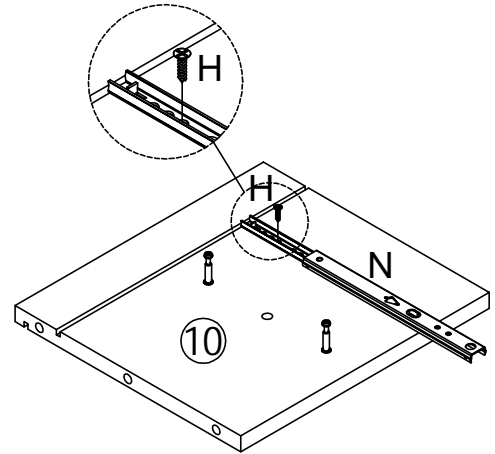
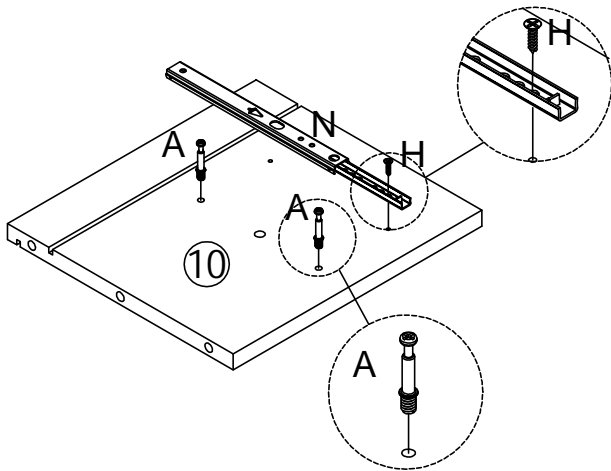
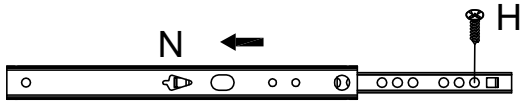

2

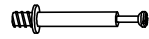

Ø6x35mm

Ⓐx2pcs



M3x14mm

Ⓗx2pcs



Ⓔx1pc

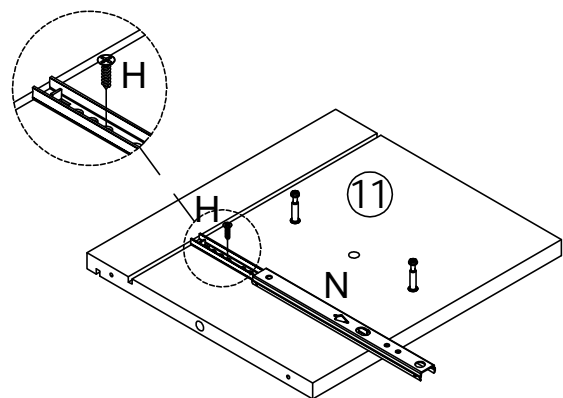
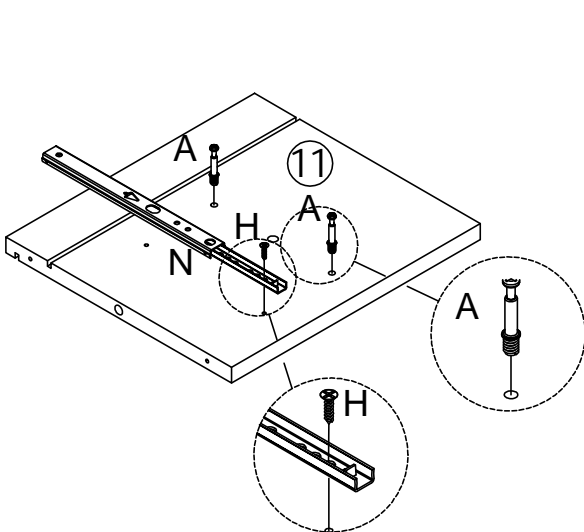
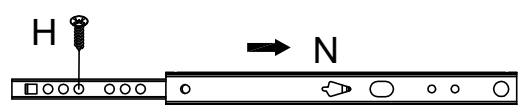
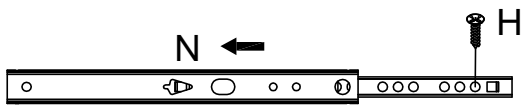

3

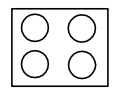
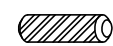
|   |   |   |
|---|---|---|
|  |  |  |
| Ø15x9mm   |   | Ø8x30mm   |
| ⓑx4pcs  | ⓐx4pcs  | ⓒx2pcs  |

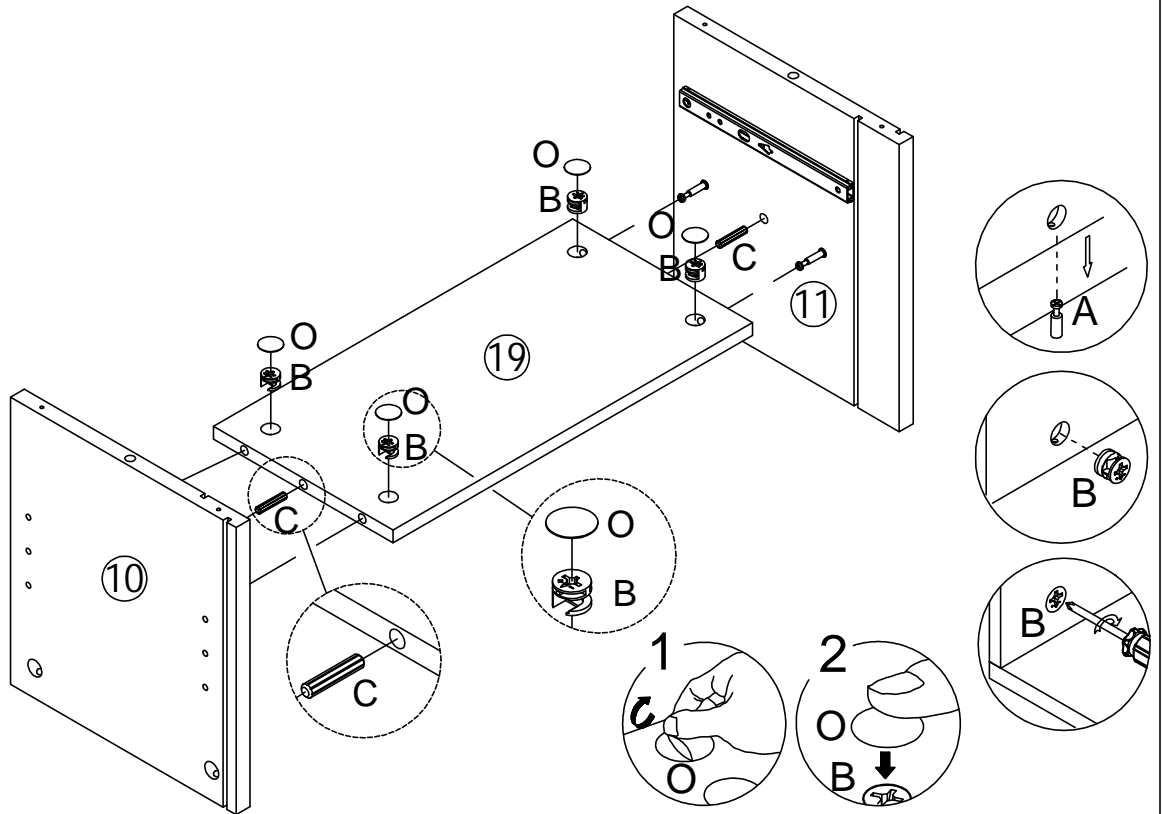

4

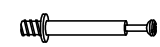
|   |
|---|
|  |
| Ø6x35mm   |
| Ⓐx11pcs   |

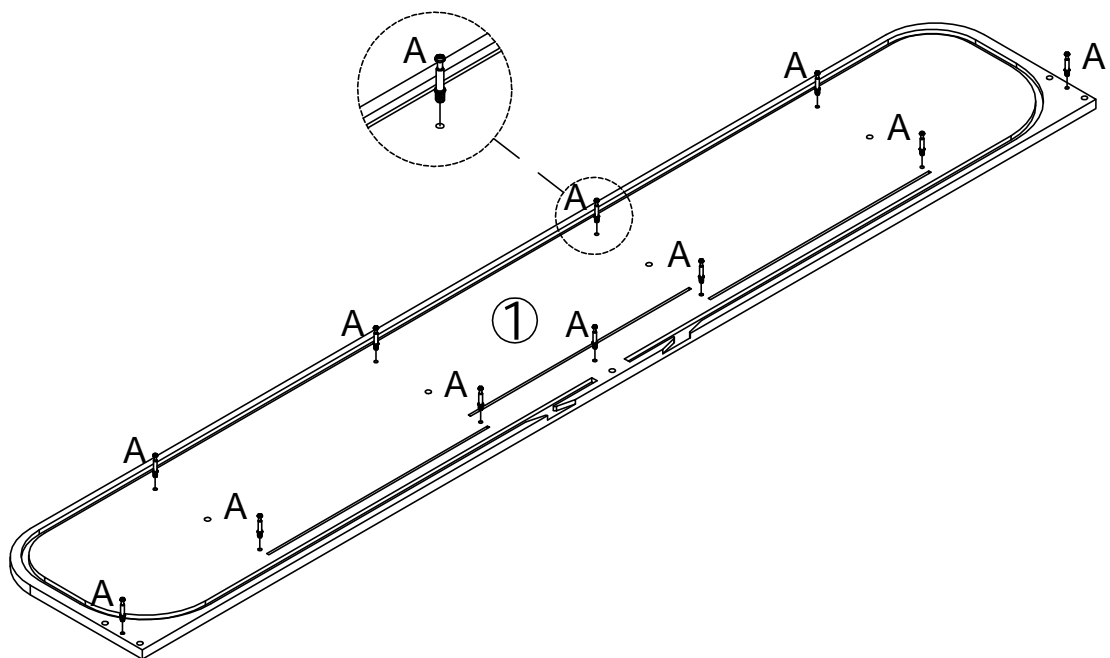

5

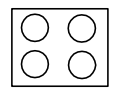
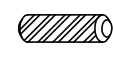
|   |   |   |
|---|---|---|
|  |  |  |
| Ø15x9mm   |   | Ø8x30mm   |
| ⓑx11pcs   | ⓐx11pcs   | ⓒx9pcs  |

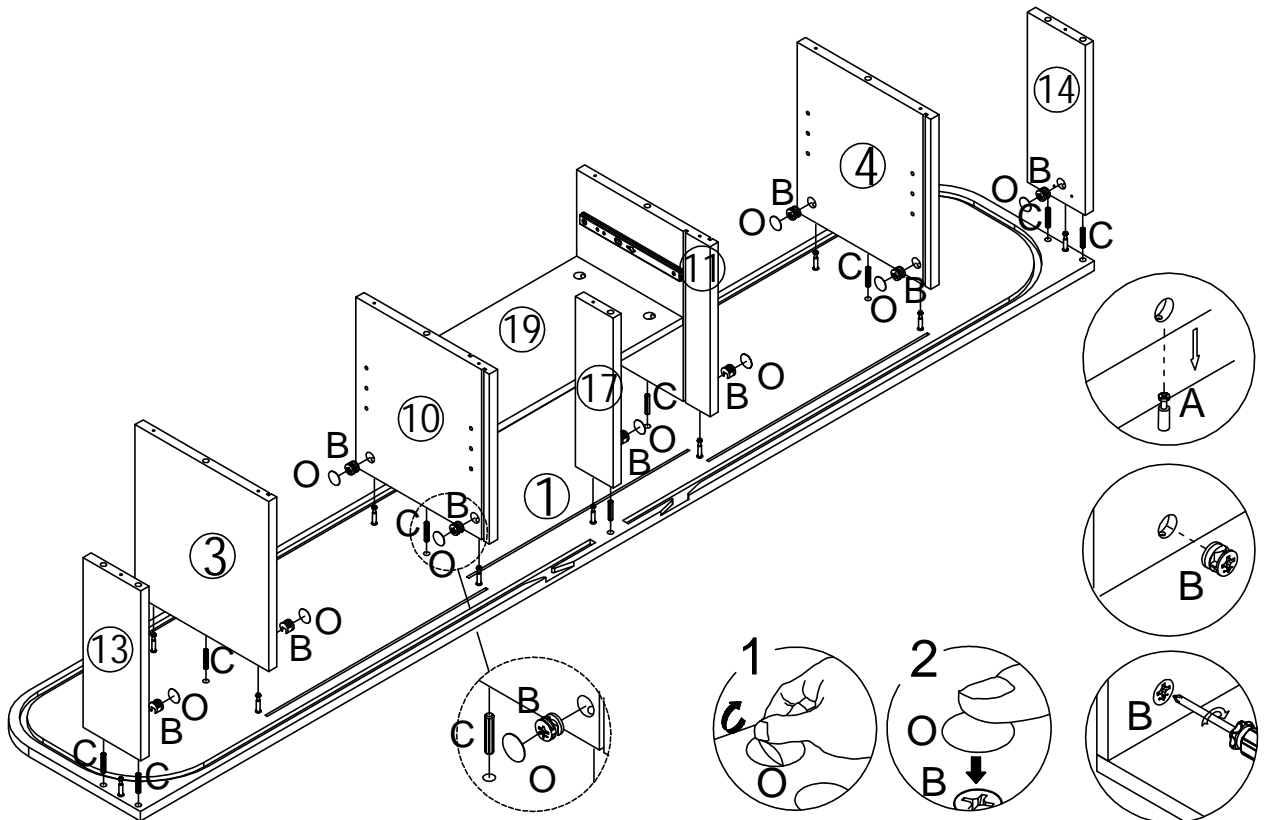

6

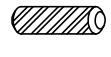
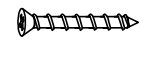
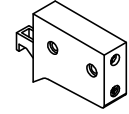
|   |   |   |
|---|---|---|
|  |  |  |
| Ø8x30mm   | Ø4x30mm   |   |
| ⓒx9pcs  | ⓔx6pcs  | Ⓛx3pcs  |

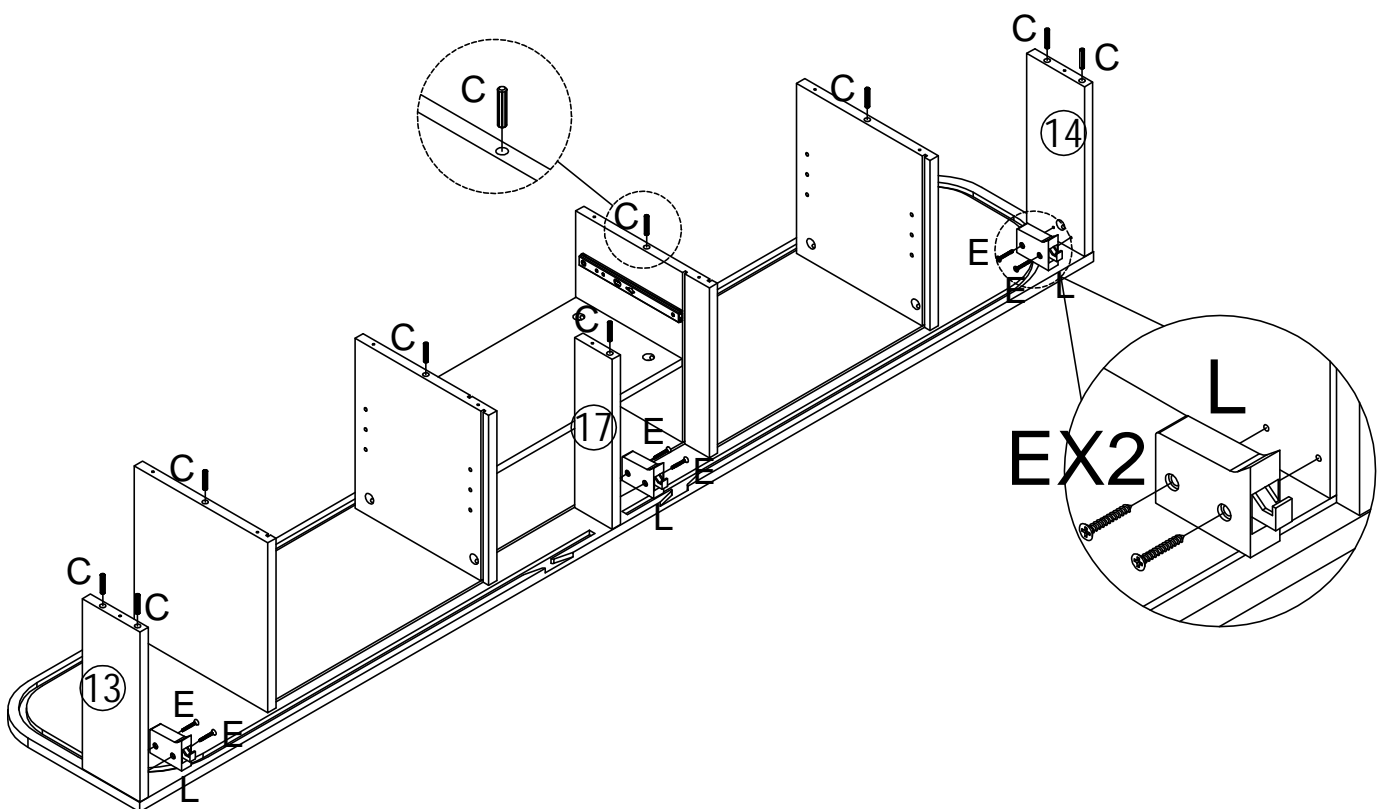

7

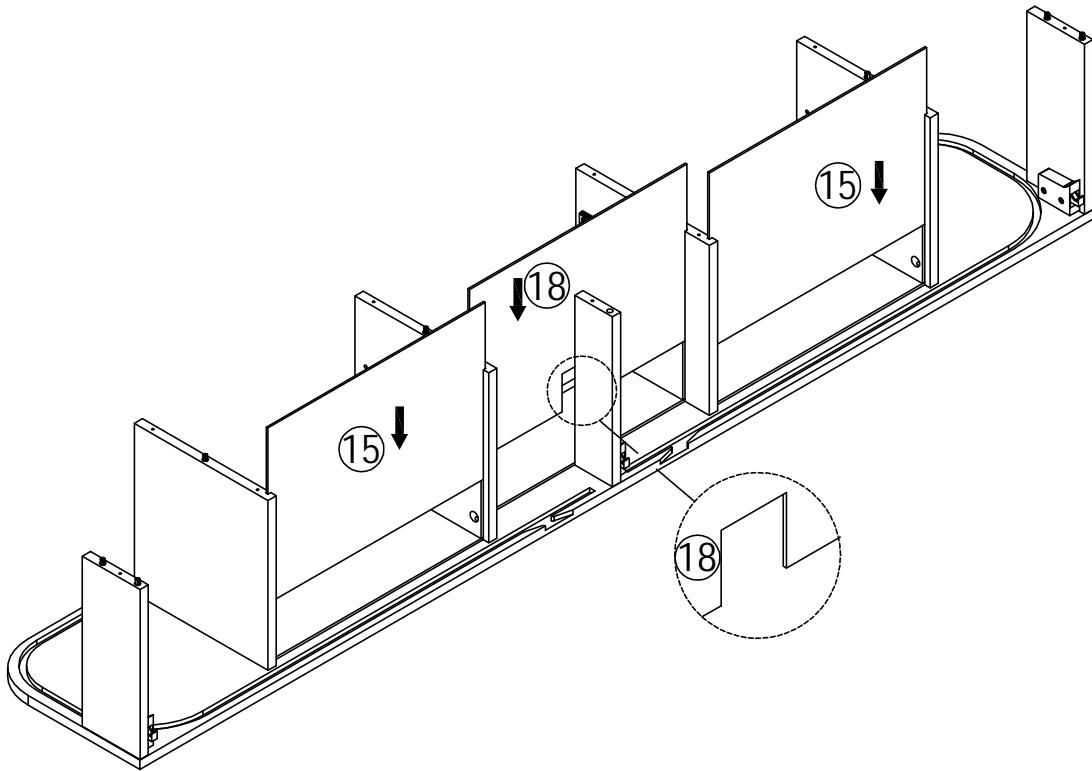

8

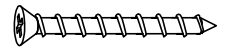
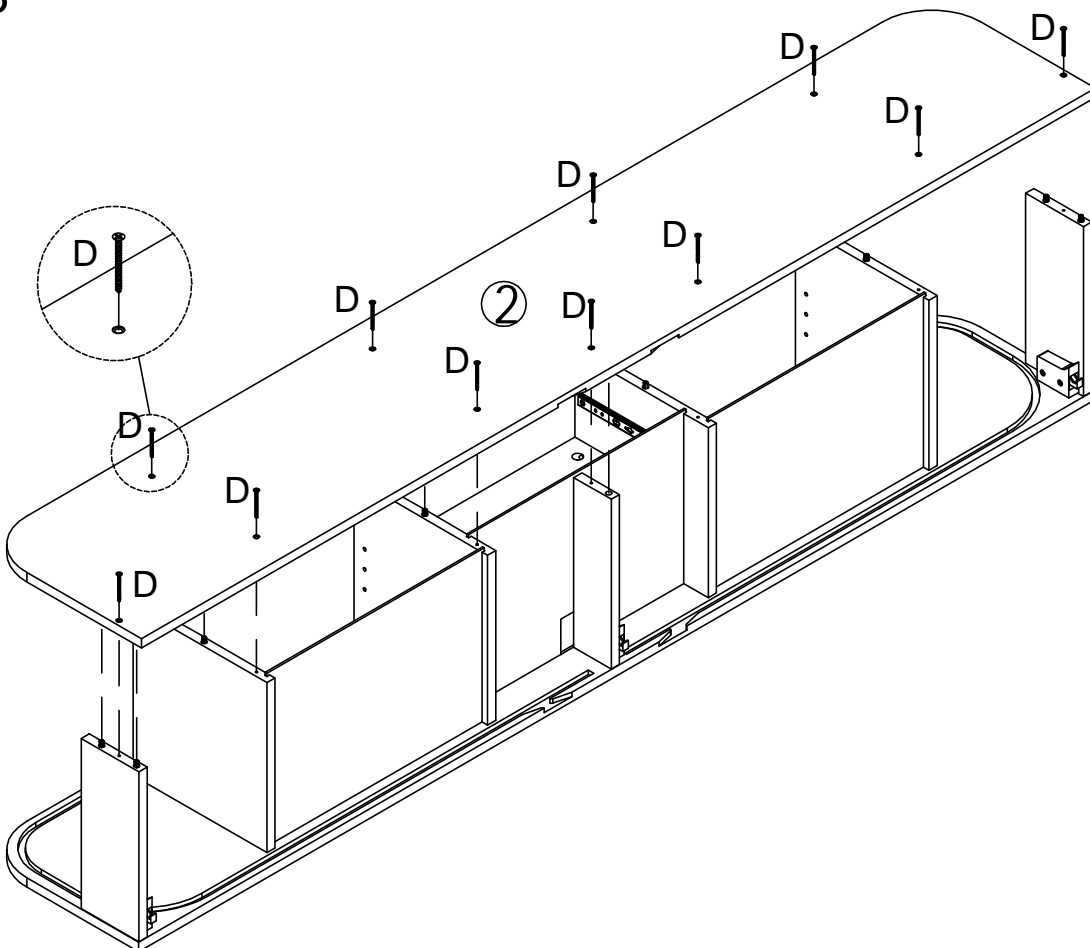

Ø4x40mm

Ⓛx11pcs

9



M3x14mm

Ⓜx12pcs

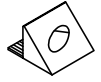

Ⓜx12pcs

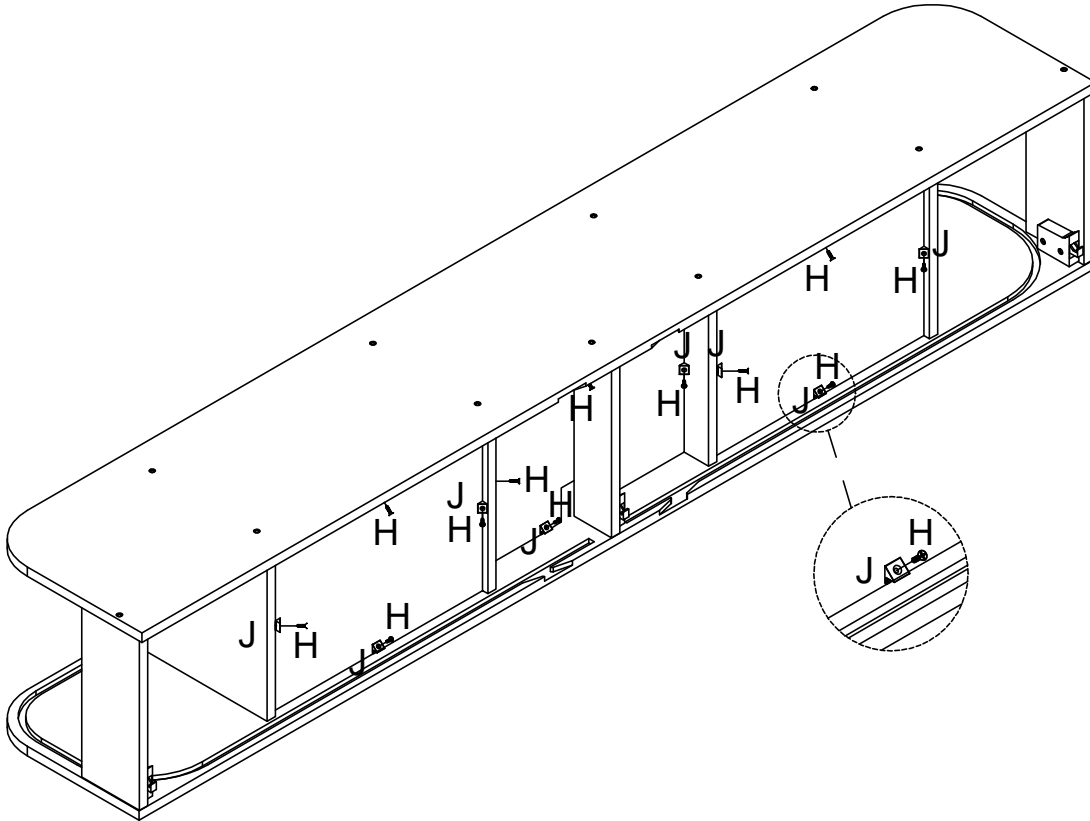

10

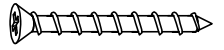

Ø4x40mm

Ⓧx6pcs

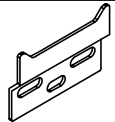

Ⓚx3pcs



Ⓧx6pcs

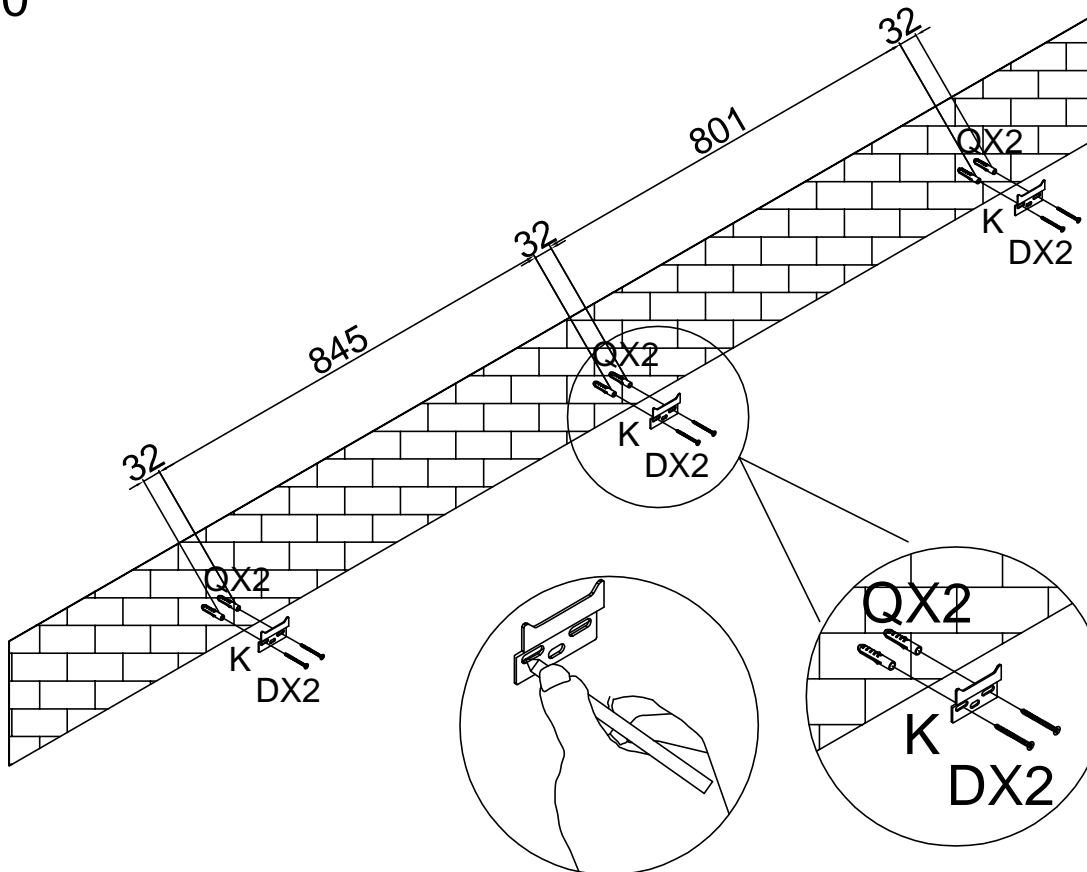

11

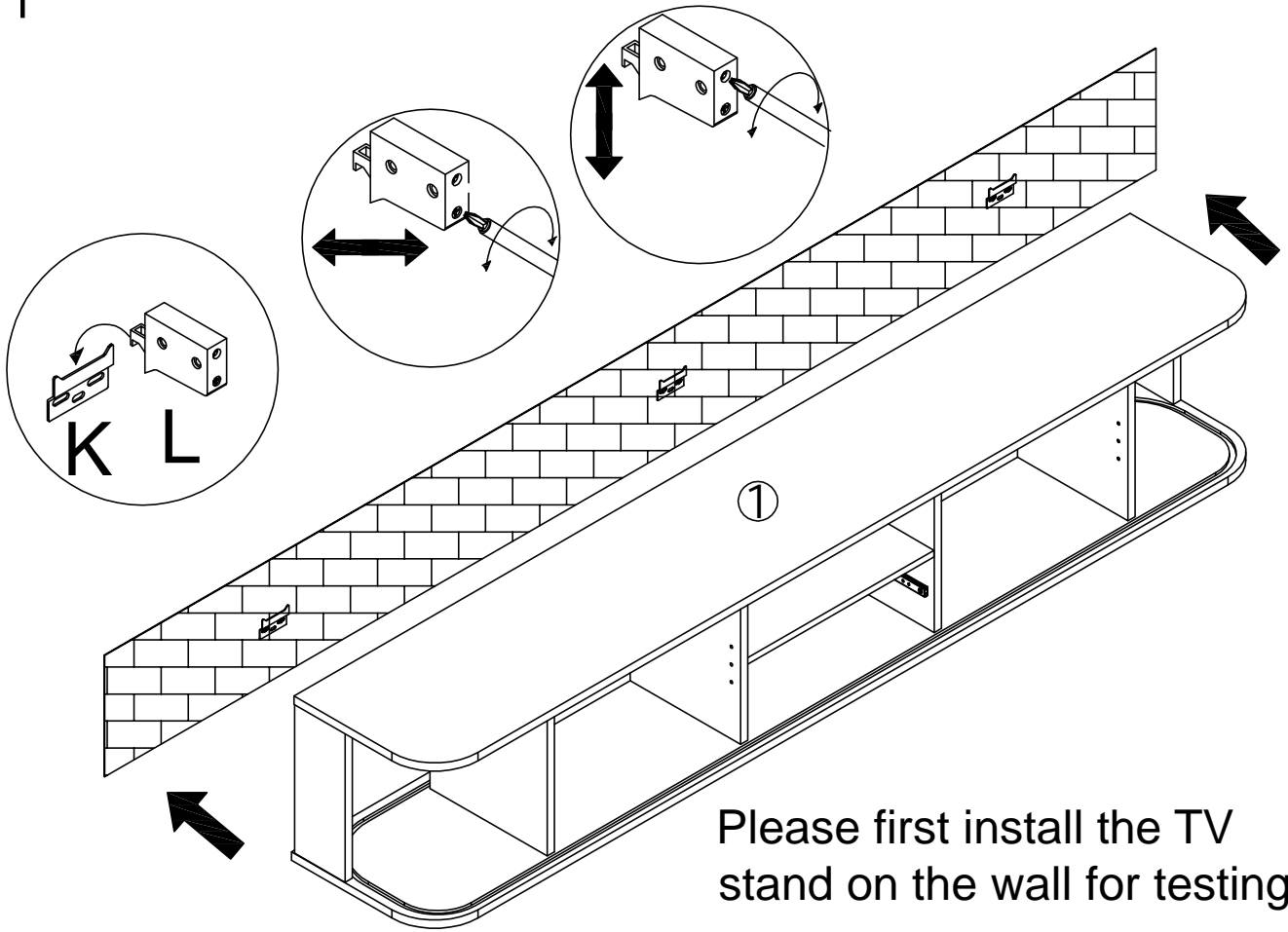

Please first install the TV stand on the wall for testing.

12

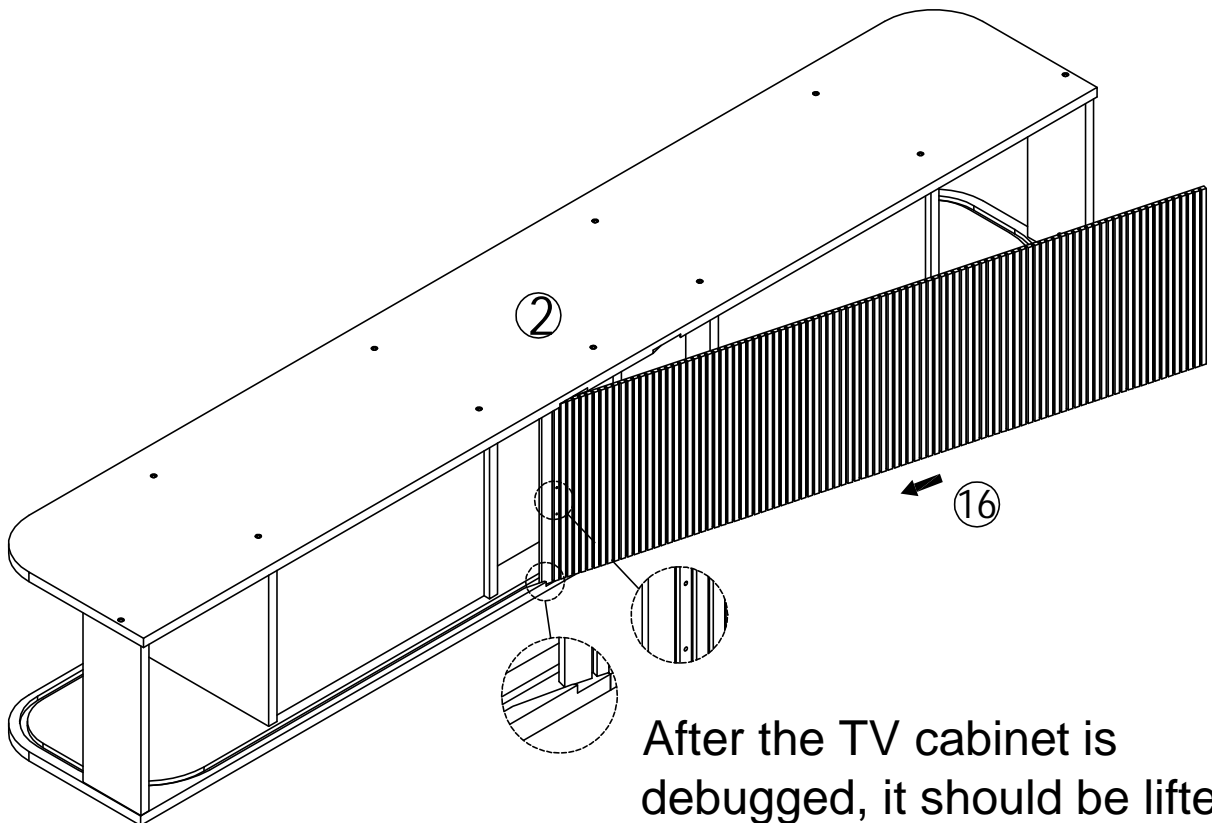

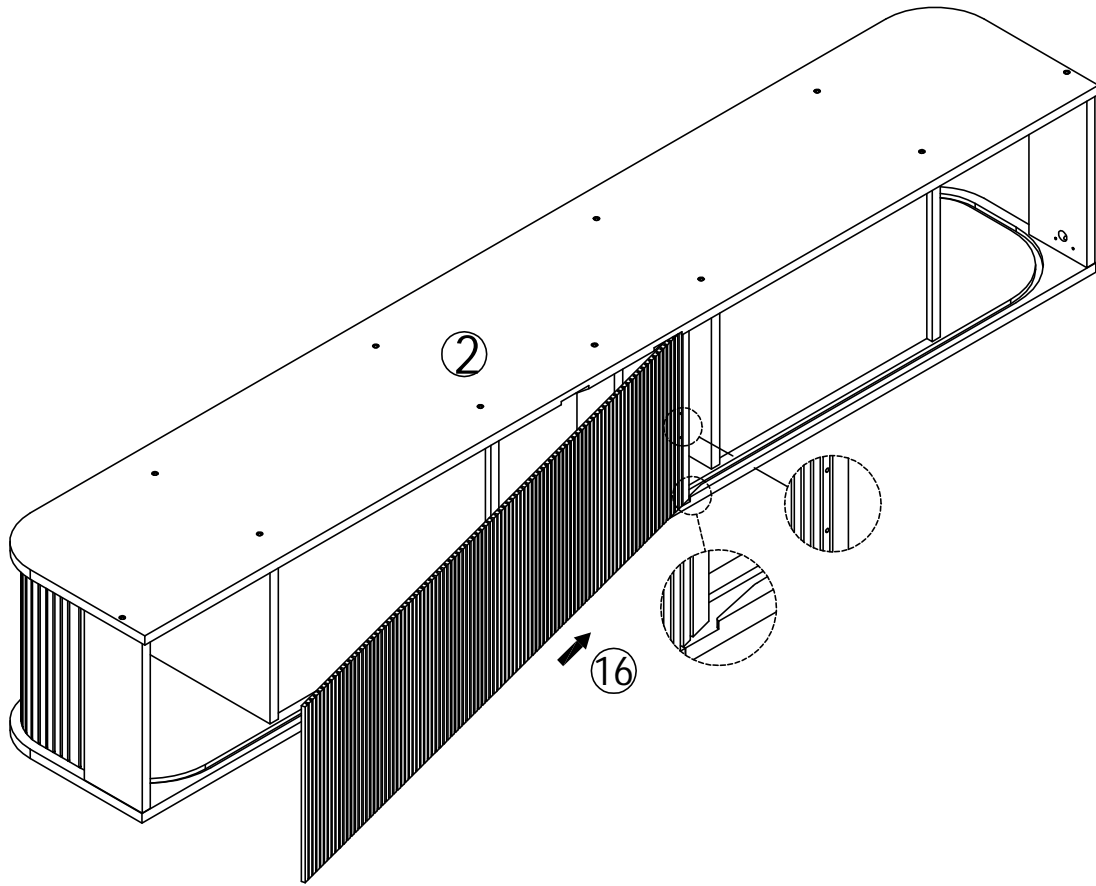

After the TV cabinet is debugged, it should be lifted down for installation first.

13

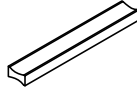

14

|   |   |
|---|---|
|  |  |
| F x 2 pcs   | M4x8mm  |
|   | 1 x 4 pcs   |

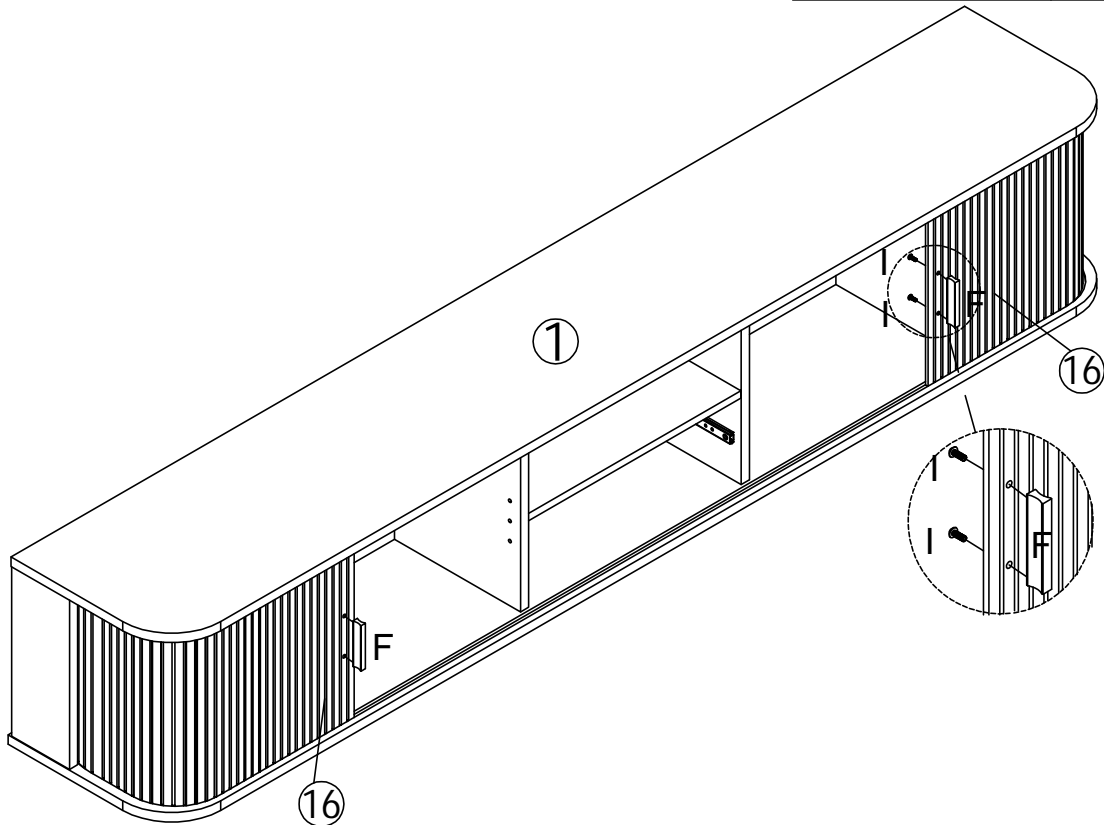

15



Ⓟx8pcs

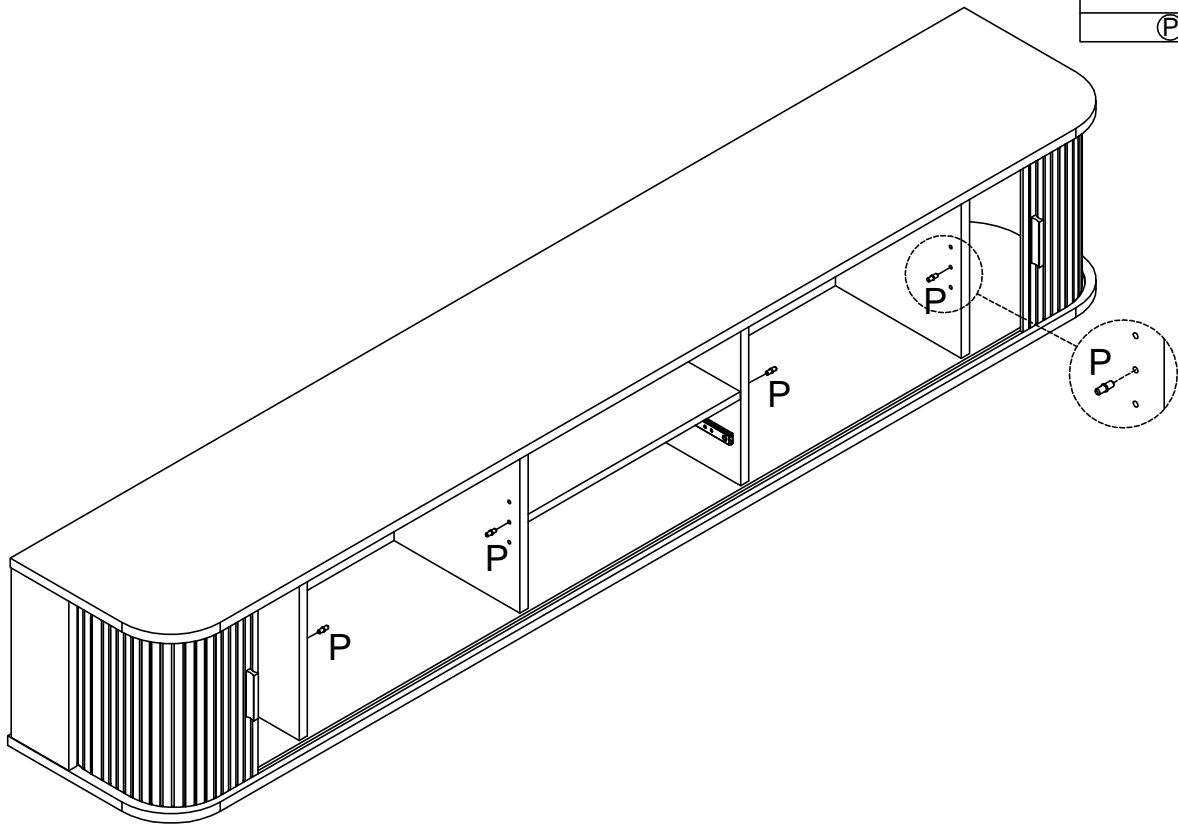

16

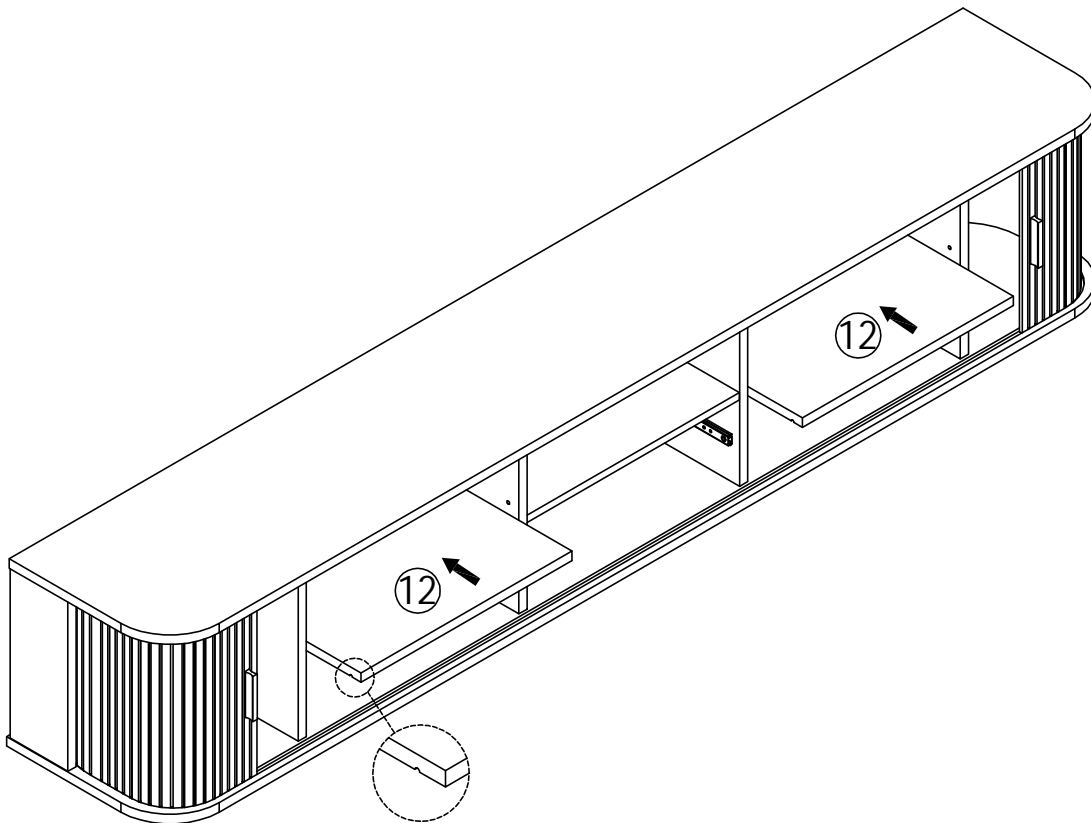

17

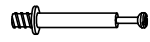

Ø6x35mm

Ⓐ x4pcs



Ø15x9mm

Ⓑ x4pcs

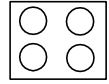

Ⓒ x4pcs

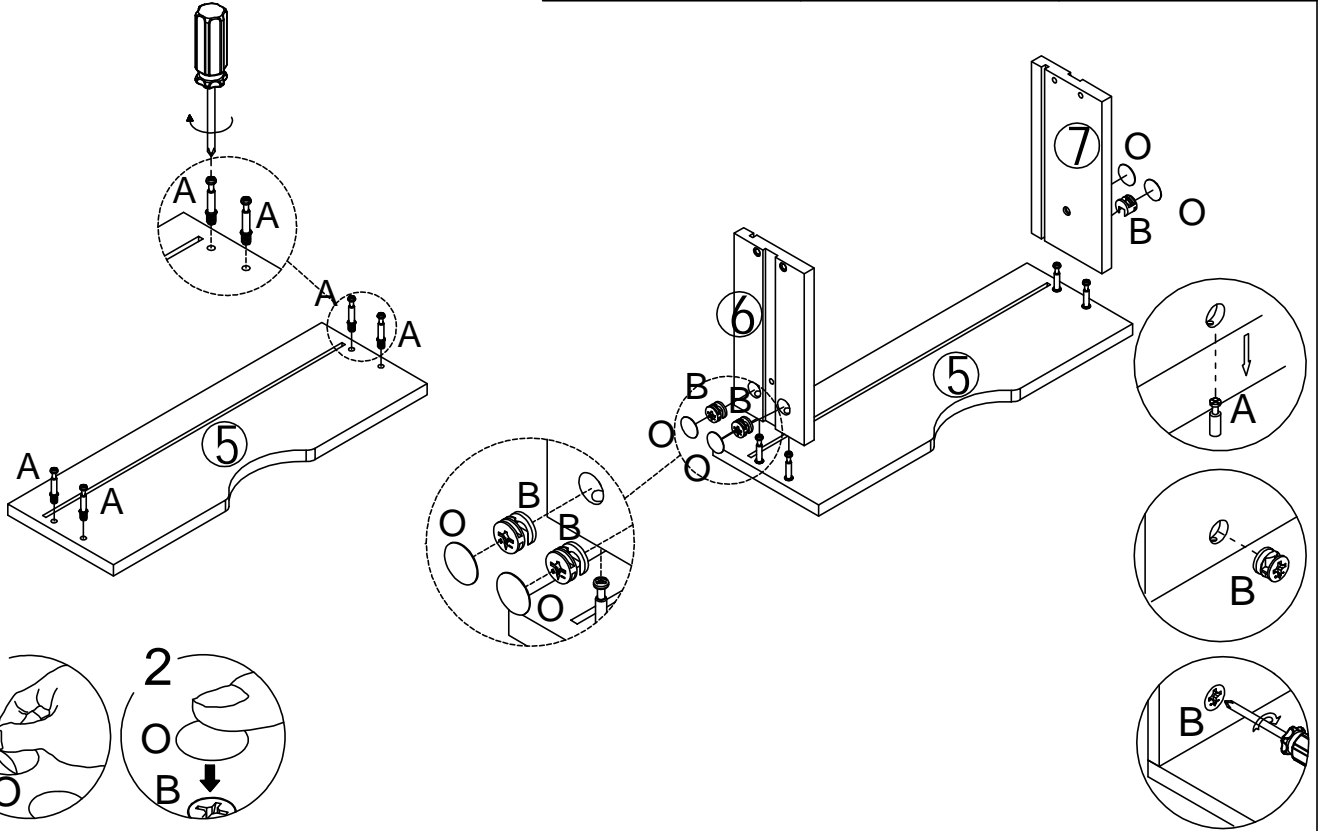

18

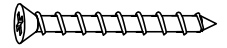

Ø4x40mm

Ⓓ x4pcs

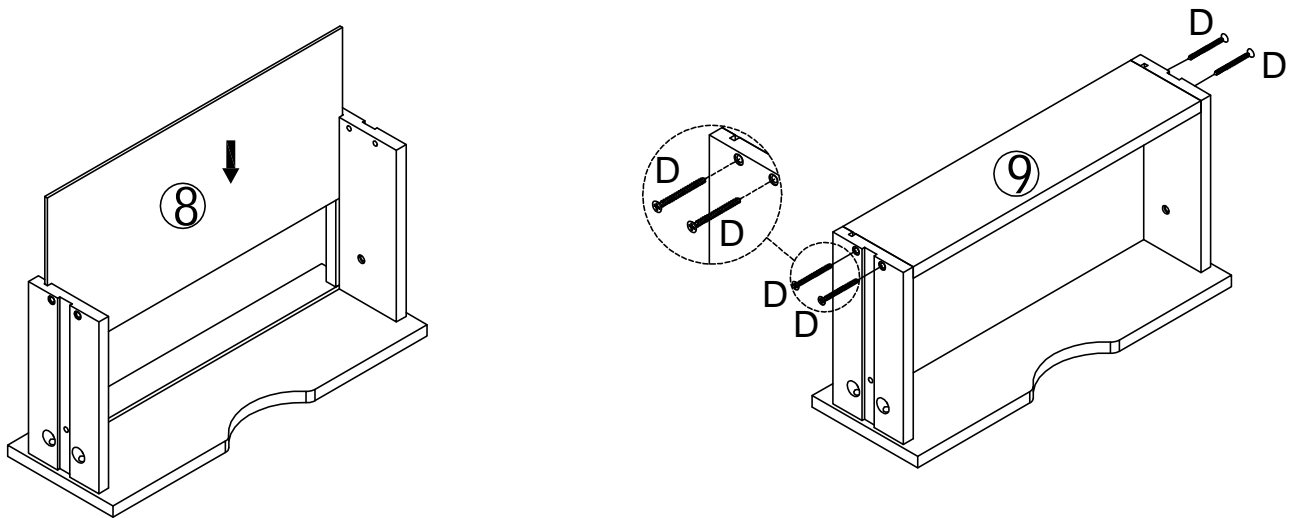

19



M4x10mm

⊕x2pcs

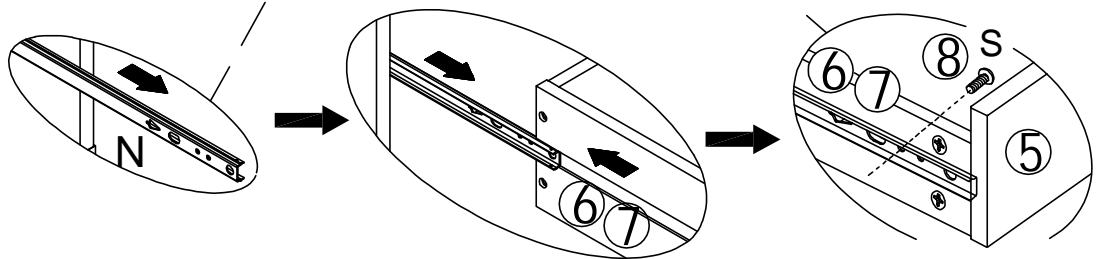
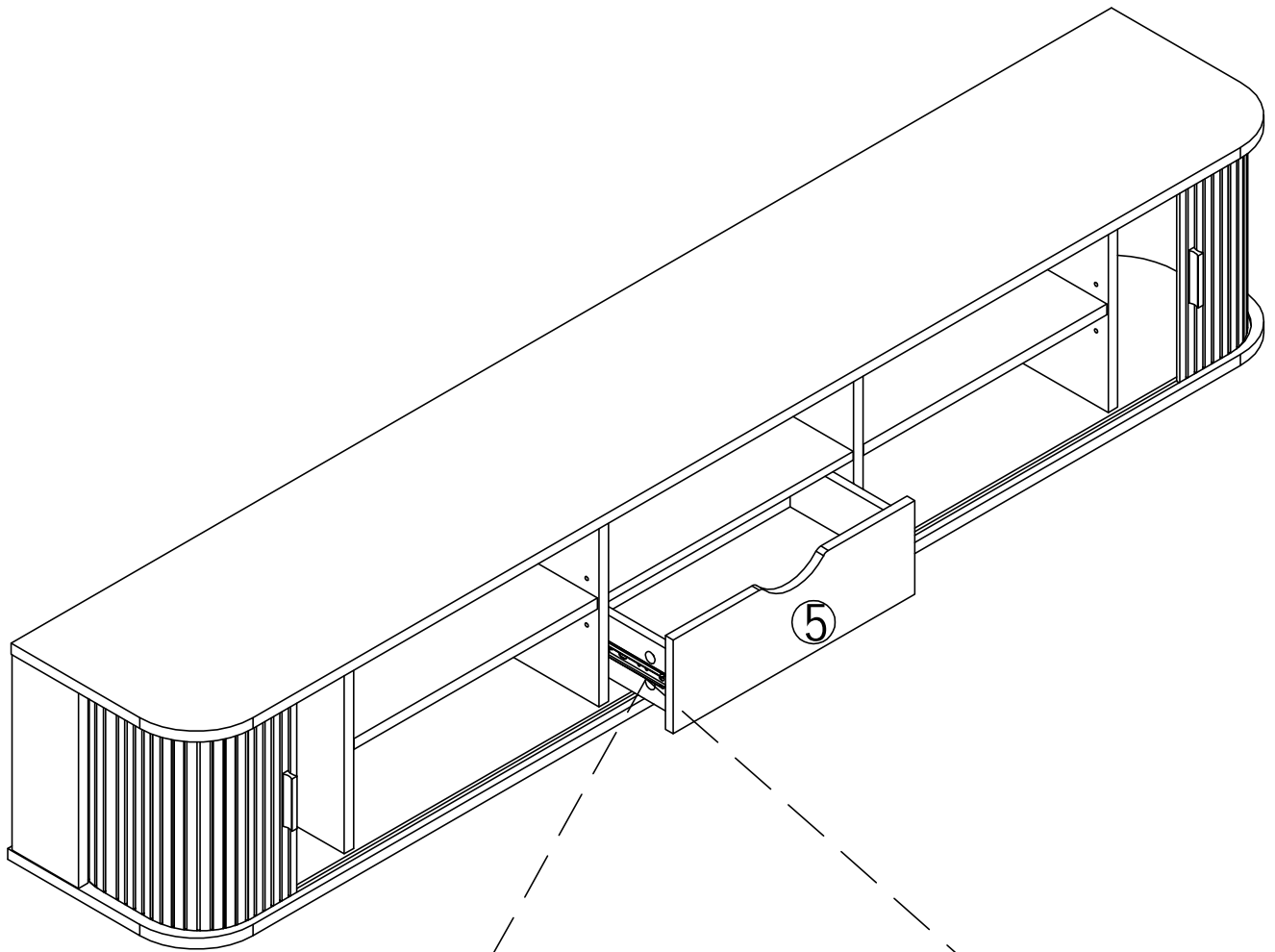

20

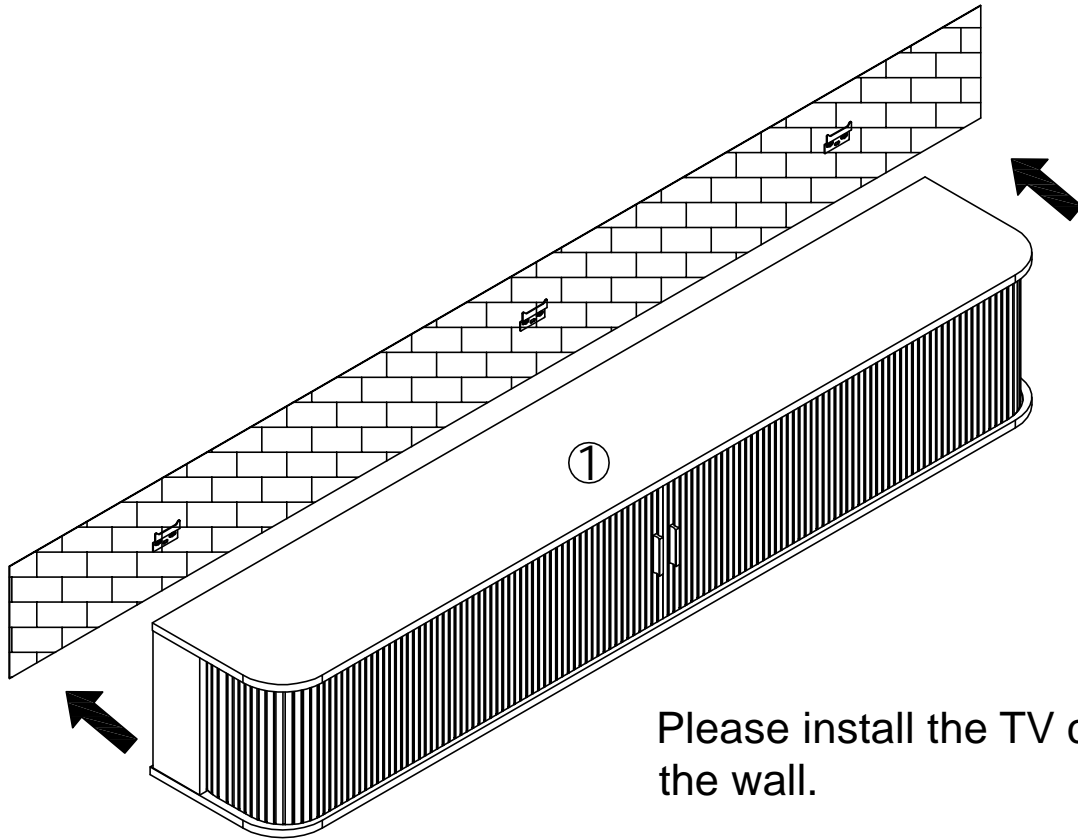

Please install the TV cabinet on the wall.

21

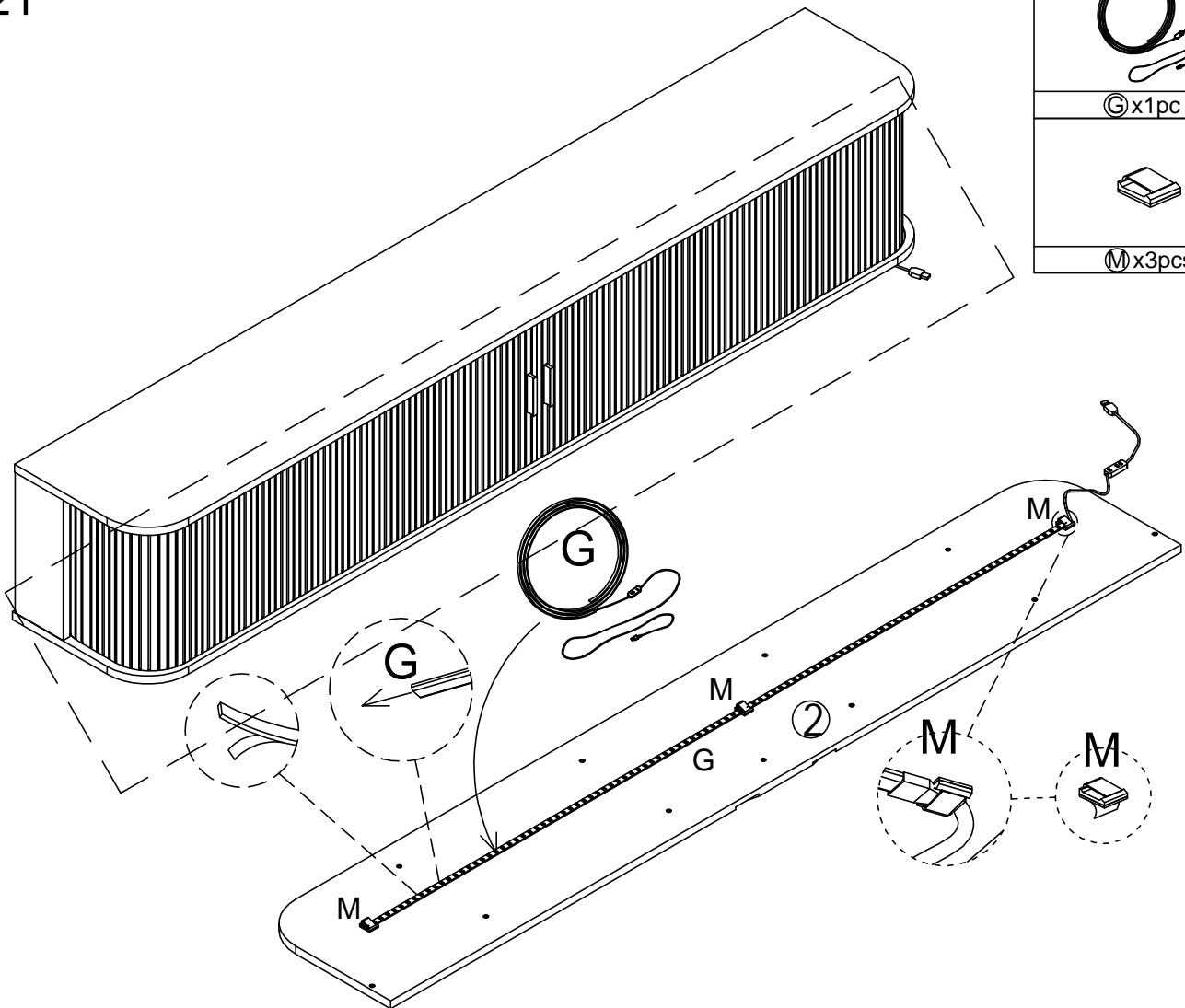

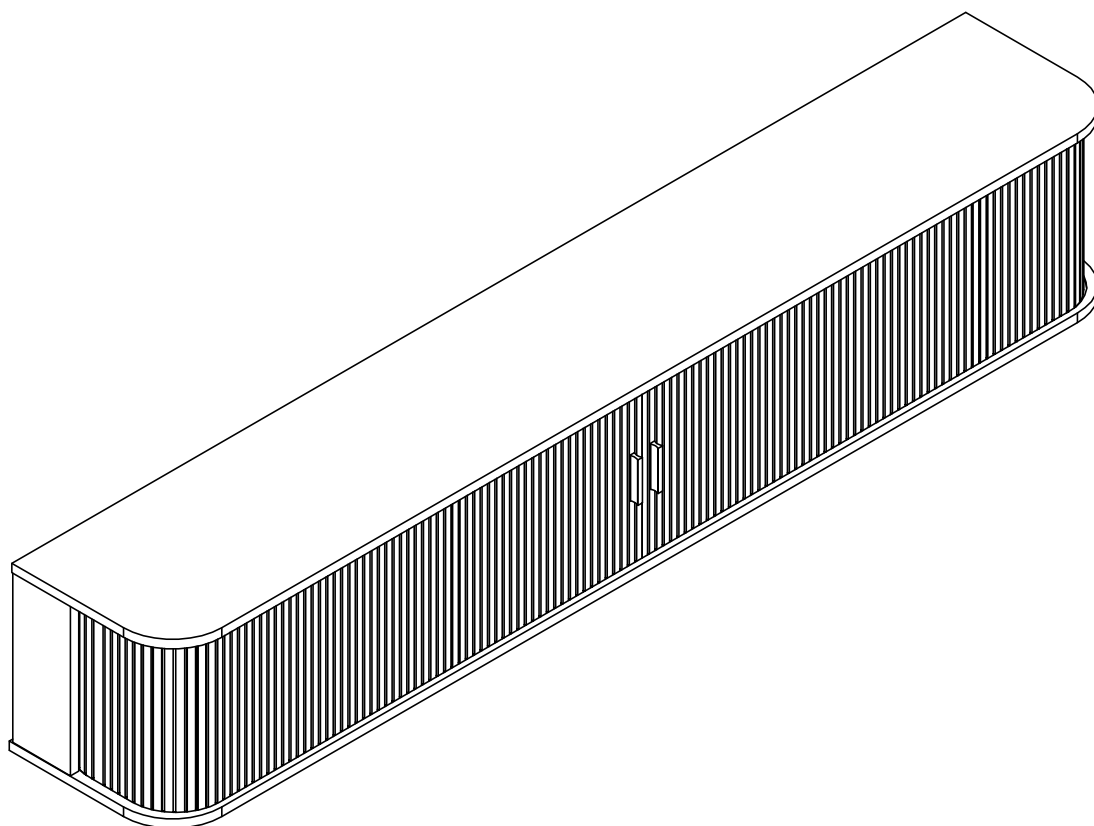

Adhesive overflow at the edges of the product can be wiped with alcohol or removed with nails. Please install the product on a carpet or with a protective pad to avoid scratches.

Überschüssiger Kleber an den Produktkanten kann mit Alkohol abgewischt oder mit Nägeln entfernt werden. Bitte installieren Sie das Produkt auf einem Teppich oder mit einer Schutzunterlage, um Kratzer zu vermeiden.

Le débordement d'adhésif sur les bords du produit peut être essuyé avec de l'alcool ou retiré avec des clous. Veuillez installer le produit sur un tapis ou avec un coussinet de protection pour éviter les rayures.

# CERTIFICATE OF COMPLIANCE

No.: AiTSZ-250710061C-C01

**Product:** 5050 RGB LED Strip Lights with Bluetooth App Controller  
**Trade Mark:** N/A  
**Model:** LED 5050 RGB  
**Applicant:** Shenzhen Pinchengxin Technology Co., Ltd  
**Address:** 3rd floor, 8 building Yuanling industrial zon, No. 39 Yuanlingcun road,Shiyan street, Bao'an district, Shenzhen  
**Manufacture:** Shenzhen Pinchengxin Technology Co., Ltd  
**Address:** 3rd floor, 8 building Yuanling industrial zon, No. 39 Yuanlingcun road,Shiyan street, Bao'an district, Shenzhen

The test sample of product has passed the test according to requirements of the following standards:

|               | Standard(s):  | Test report(s) No.: |
|---------------|---|---------------------|
| Article 3.1a) | EN IEC 62368-1:2020+A11:2020  | AiTSZ-250710061S    |
|               | EN 62479: 2010<br>EN 50663: 2017  | AiTSZ-250710061CW3  |
| Article 3.1b) | ETSI EN 301 489-1 V2.2.3 (2019-11)<br>ETSI EN 301 489-17 V3.2.4 (2020-09) | AiTSZ-250710061CW1  |
| Article 3.2)  | ETSI EN 300 328 V2.2.2 (2019-07)  | AiTSZ-250710061CW2  |

Based on the voluntary assessment of the product sample and technical file, we confirm that the above-mentioned product meets the essential requirements of the Radio Equipment Directive (RED) 2014/53/EU.

The CE mark as show below can be used, under the responsibility of the manufacturer or the importer, after completion of an EC declaration of conformity and follow the CE mark usage rules.



Approved by/Date:

*Sean She*  
Sean She

July 23, 2025



The statement is based on a single evaluation of one sample of above mentioned products. It does not imply an assessment of the whole production and does not permit the use of the test lab's logo.

## Guangdong Asia Hongke Test Technology Limited

B1/F, Building 11, Junfeng Industrial Park, Chongqing Road, Heping Community, Fuhai Street,  
Bao'an District, Shenzhen, Guangdong, China  
www.aitek.org.cn  
E-mail:info@aitek.org.cn



# Certificate of Compliance

Certificate No.: AiTSZ-250710061RC09

The EUT described above has been consolidated by us and found in compliance with the council RoHS 2.0 Directive(EU)2015/863and(EU)2017/2102 amending Annex I to Directive2011/65/EU.

**Applicant** : Shenzhen Pinchengxin Technology Co., Ltd  
**Address** : 3rd floor, 8 building Yuanling industrial zon, No. 39 Yuanlingcun road, Shiyan street, Bao'an district, Shenzhen  
**Manufacturer** : Shenzhen Pinchengxin Technology Co., Ltd  
**Address** : 3rd floor, 8 building Yuanling industrial zon, No. 39 Yuanlingcun road, Shiyan street, Bao'an district, Shenzhen  
**Product** : 5050 RGB LED Strip Lights with Bluetooth App Controller  
**Model No.** : LED 5050 RGB  
**Trade mark** : N/A  
**Test Report No.** : AiTSZ-250710061R

## Test Standards:

IEC 62321-3-1: 2013  
IEC 62321-4:2013+AMD1:2017 CSV  
IEC 62321-5:2013  
IEC 62321-6:2015  
IEC 62321-7-1:2015  
IEC 62321-7-2:2017  
IEC 62321-8:2017

# RoHS

*Lizhen*

Lizhen

Date: Jul.18, 2025



The statement is based on a single evaluation of one sample of above mentioned products. It does not imply an assessment of the whole production and does not permit the use of the test lab logo.



**Guangdong Asia Hongke Test Technology Co.,Ltd.**

B1/F, Building 11, Junfeng Industrial Park, Chongqing Road, Heping Community, Fuhai Street, Bao'an District, Shenzhen, Guangdong, China  
Tel:+86. 0755-23096763

<https://www.aitek.org.cn>

E-mail:info@aitek.org.cn