

Installation sanleitung Installation Instruction Instruction d'installation

SKU:N879P450333

SKU:N879P450334

SKU:N879P450335

SKU:N879P450336

Metall-Hochbett 140x200cm

Importeur	Decobus Handel GmbH
Adresse	Innungsstraße 9,21244 Buchholz,Deutschland
URL	https://www.decobusgroup.de
Hersteller	Zhangzhou Sunnyday Industrial CO.,Ltd.
Adresse	Chaosheng Road308#,Chaoyang Town, Longwen Bourough,Zhangzhou City, Fujian Province,China.
Email/URL	shipping@lifefurniture.cn
	Decobus Handel GmbH Innungsstraße 9,21244 Buchholz,Deutschland https://www.decobusgroup.de
EC	REP



Points de collecte sur www.quefaredemesdechets.fr
Privilégiez la réparation ou le don de votre appareil !

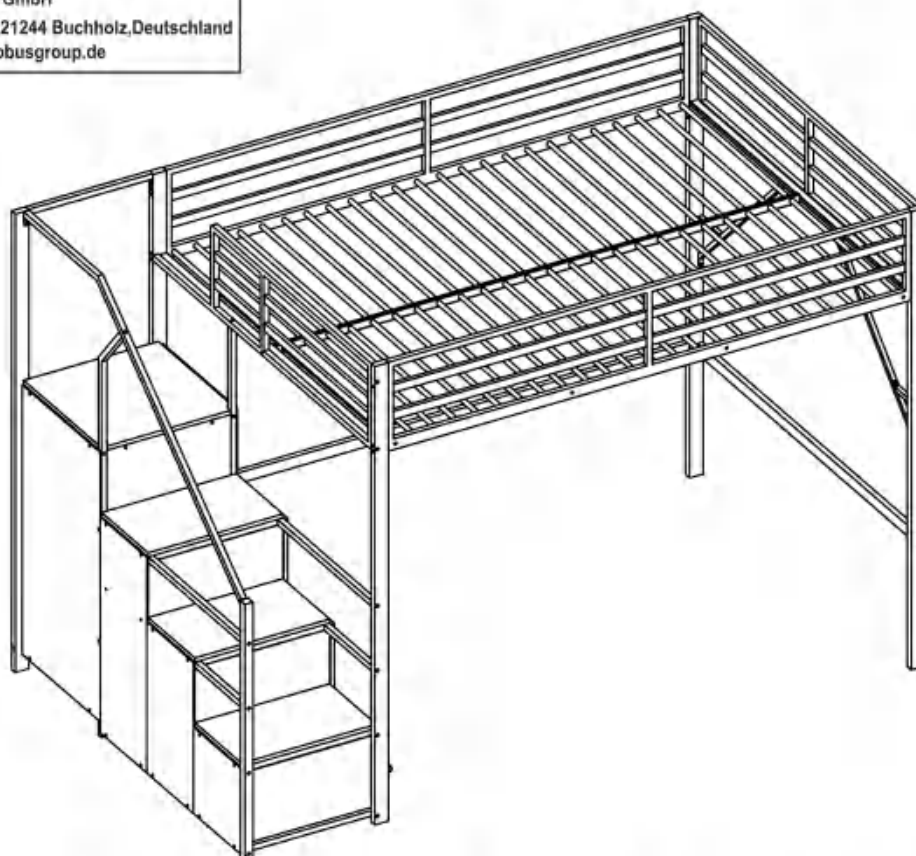

Unser Produkt wird Ihnen in 4 Paketen geliefert. Die Lieferzeiten dieser 4 Pakete können abweichen, bitte haben Sie etwas Geduld und vielen Dank für Ihr Verständnis.

Our product will be delivered to you in 4 packages. The delivery times of these 4 packages may differ, please be patient and thank you for your understanding.

Notre produit vous sera livré en 4 colis. Les délais de livraison de ces 4 colis peuvent différer, soyez patient et merci pour votre compréhension.

ANLEITUNG

WICHTIG - SORGFÄLTIG DURCHLESEN – FÜR ZUKÜNFTIGE REFERENZ BEWAHREN

- a) **WARNUNG** - Hochbetten und das Oberbett von Etagenbetten sind wegen der Verletzungsgefahr durch Stürze nicht für Kinder unter sechs Jahren geeignet.
- b) **WARNUNG** - Etagenbetten und Hochbetten können ein ernstes Verletzungsrisiko darstellen, wenn sie nicht ordnungsgemäß verwendet werden. Befestigen oder hängen Sie niemals Gegenstände an einem Teil des Etagenbetts, die nicht für die Verwendung mit dem Bett vorgesehen sind, zum Beispiel Schnüre, Kordeln, Haken, Gurte und Taschen.
- c) **WARNUNG** - Kinder können zwischen Bett und Wand eingeklemmt werden. Um die Gefahr schwerer Verletzungen zu vermeiden, darf der Abstand zwischen der oberen Sicherheitsbarriere und der angrenzenden Konstruktion 75 mm nicht überschreiten oder mehr als 230 mm betragen.
- d) **WARNUNG** - Verwenden Sie das Etagenbett / Hochbett nicht, wenn ein Bauteil beschädigt ist oder fehlt. Ersatzteile werden zwischendurch beim Hersteller oder beim Händler angefordert.
- e) Befolgen Sie unbedingt die Installationsanweisungen und die Gebrauchsanweisung des Herstellers.
- f) Die empfohlene Größe der Matratze für das Bett beträgt 200 cm x140cm, maximale Dicke der Matratze: 10 cm.
- g) Es ist notwendig, den Raum zu lüften, um ein niedriges Feuchtigkeitsniveau aufrechtzuerhalten und das Wachstum von Schimmel im Bett und an dessen Peripherie zu verhindern.
- h) Verbindungselemente sollten immer richtig angezogen und regelmäßig überprüft werden. Bei Bedarf festziehen.
- i) **WARNUNG** - sorgt dafür, dass die Stufen mit der Leiter/Treppe dauerhaft mit diesem Bereich verbunden sind. Gehen Sie schlafen, bevor Sie benutzen."
- J) **WARNUNG** - das Produkt muss an eine Wand oder eine architektonische Struktur angeschlossen sein.

INSTRUCTIONS

IMPORTANT - À LIRE ATTENTIVEMENT - CONSERVER POUR RÉFÉRENCE ULTÉRIEURE

- a) **AVERTISSEMENT** - Les lits surélevés et le lit supérieur des lits superposés ne conviennent pas aux enfants de moins de six ans en raison du risque de blessure dû à une chute;
- b) **AVERTISSEMENT** - Les lits superposés et les lits surélevés peuvent présenter un risque sérieux de blessure par strangulation s'ils ne sont pas utilisés correctement. Ne jamais attacher ou suspendre à des parties du lit superposé des objets qui ne sont pas conçus pour être utilisés avec le lit, par exemple, mais ne se limitant pas à des cordes, des ficelles, des cordes, des crochets, des ceintures et des sacs.
- c) **AVERTISSEMENT** - Les enfants peuvent rester coincés entre le lit et le mur, un toit incline les meubles adjacents au plafond (par exemple, des armoires), etc. Pour éviter tout risque de blessure grave, la distance entre la barrière de sécurité supérieure et la structure adjacente ne doit pas dépasser 75 mm ou doit être supérieure à 230 mm.
- d) **AVERTISSEMENT** - N'utilisez pas le lit superposé / le lit surélevé si une partie de la structure est cassée ou manquante. Les pièces de rechange sont demandées au fabricant ou au magasin.
- e) Il est impératif de toujours suivre les instructions d'installation et l'utilisation du fabricant.
- f) La taille recommandée du matelas à utiliser avec le lit est 200 cm x140cm, épaisseur maximale du matelas: 10 cm.
- g) Il est nécessaire de ventiler la pièce afin de maintenir un faible niveau d'humidité et d'empêcher la formation de moisissure dans le lit et à sa périphérie.
- h) Les dispositifs de jonction doivent toujours être correctement serrés et vérifiés régulièrement. Serrer si nécessaire.
- i) **AVERTISSEMENT** - assurez-vous toujours que la plate-forme et l'échelle/escalier sont fixés en permanence à cette couchette Lit avant utilisation"
- J) **AVERTISSEMENT** - "ce produit doit être fixé à un mur ou à une structure de bâtiment"

INSTRUCTIONS

IMPORTANT - READ CAREFULLY - RETAIN FOR FUTURE REFERENCE

- a) **WARNING** - High beds and the upper bed of bunk beds are not suitable for children under six years due to the risk of injury from falls;
- b) **WARNING** - Bunk beds and high beds can present a serious risk of injury from strangulation if not used correctly. Never attach or hang items to any part of the bunk bed that are not designed to be used with the bed, for example, but not limited to ropes, strings, cords, hooks, belts and bags.
- c) **WARNING** - Children can become trapped between the bed and the wall, a roof pitch, the ceiling adjoining pieces of furniture (e.g. cupboards) and the like. To avoid risk of serious injury the distance between the top safety barrier and the adjoining structure shall not exceed 75 mm or shall be more than 230 mm.
- d) **WARNING** - Do not use the bunk bed/high bed if any structural part is broken or missing. Replacement parts are between requested from the manufacturer of the store.
- e) it is imperative to always follow the installation instructions and manufacturer's use.
- f) The recommended size of the mattress to be used with the bed is 200cm x140cm, maximum thickness mattress: 10cm.
- g) It is necessary to ventilate the room in order to maintain a low level moisture and prevent mold growth in the bed and its periphery.
- h) Joining devices should always be tightened properly and regularly verified. Tighten if necessary.
- i) **WARNING** - "Always ensure the platform and the ladder / stairs are permanently attached to this bunkbed before use"
- j) **WARNING** - "This product must be attached to a wall or building structure"

ISTRUZIONI

IMPORTANTE - LEGGERE ATTENTAMENTE - CONSERVARE IL FUTURO RIFERIMENTO

- a) **ATTENZIONE** - I letti alti e il letto superiore a castello non sono adatti a bambini di età inferiore ai sei anni a causa del rischio di lesioni da cadute;
- b) **AVVERTENZA** - I letti a castello e i letti alti possono presentare un serio rischio di lesioni a causa di strangolamento se non utilizzati correttamente. Non attaccare o appendere mai oggetti a qualsiasi parte del letto a castello che non sono progettati per essere utilizzati con il letto, ad esempio, ma non limitato a corde, corde, corde, ganci, cinture e borse.
- c) **AVVERTENZA** - I bambini possono rimanere intrappolati tra il letto e la parete, un tetto inclinato il mobile adiacente al soffitto (ad es. armadi) e simili. Per evitare il rischio di gravi lesioni, la distanza tra la barriera di sicurezza superiore e a struttura adiacente non deve superare 75 mm o deve essere superiore a 230 mm.
- d) **ATTENZIONE** - Non utilizzare il letto a castello / letto alto se qualche parte strutturale è rotta o mancante; Le parti di ricambio sono tra quelle richieste al produttore o al negozio.
- e) è indispensabile seguire sempre le istruzioni di installazione e l'uso del produttore.
- f) Le dimensioni consigliate del materasso da utilizzare con il letto sono 200 cm x 140cm, materasso di massimo spessore: 10 cm.
- g) È necessario ventilare l'ambiente per mantenere un'umidità bassa e prevenire la formazione di muffe nel letto e nella sua periferia.
- h) I dispositivi di giunzione devono essere sempre serrati correttamente e regolarmente verificati. Stringere se necessario.
- i) **ATTENZIONE** - "assicurarsi sempre che il marciapiede e la scala/scalino siano fissati in modo permanente a questa cuccetta Letto prima dell'uso"
- J) **ATTENZIONE** - "questo prodotto deve essere fissato a una parete o a una struttura di costruzione"

INSTRUCTIES

BELANGRIJK - LEES AANDACHTIG - BEWAAR VOOR TOEKOMSTIGE REFERENTIE

- a) **WAARSCHUWING** - Hoge bedden en het bovenste bed van stapelbedden zijn niet geschikt voor kinderen jonger dan zes jaar vanwege het risico op letsel door vallen;
- b) **WAARSCHUWING** - Stapelbedden en hoge bedden kunnen een ernstig risico op verwonding vormen als ze niet correct worden gebruikt. Bevestig of hang nooit items aan een deel van het stapelbed die niet zijn ontworpen voor gebruik met het bed, bijvoorbeeld, maar niet beperkt tot touwen, koorden, koorden, haken, riemen en tassen.
- c) **WAARSCHUWING** - Kinderen kunnen vast komen te zitten tussen het bed en de muur, een dakhelling het plafond aangrenzende meubels (bijv. kasten) en dergelijke. Om het risico van ernstig letsel te voorkomen, mag de afstand tussen de bovenste veiligheidsbarrière en de aangrenzende structuur niet groter zijn dan 75 mm of meer dan 230 mm.
- d) **WAARSCHUWING** - Gebruik het stapelbed / hoogbed niet als een structureel onderdeel kapot is of ontbreekt; Vervangende onderdelen worden tussen gevraagd door de fabrikant of de winkel.
- e) Het is noodzakelijk om altijd de installatie-instructies en het gebruik van de fabrikant te volgen.
- f) De aanbevolen maat van de matras die met het bed wordt gebruikt, is 200 cm x140cm, maximale dikte matras: 10 cm.
- g) Het is noodzakelijk om de kamer te ventileren om een laag vochtgehalte te handhaven en schimmelgroei in het bed en de periferie ervan te voorkomen.
- h) Verbindingsinrichtingen moeten altijd goed worden vastgedraaid en regelmatig worden gecontroleerd. Draai indien nodig vast.
- i) **WAARSCHUWING** - zorg ervoor dat het platform en de ladder/trap permanent verbonden zijn met deze kooi.
Slapen voor gebruik"
- j) **WAARSCHUWING** - dit product moet worden bevestigd aan muren of gebouwen.

IINSTRUKCJE

WAŽNE - PRZECZYTAJ UWAŻNIE - ZACHOWAJ NA PRZYSZŁOŚĆ

- a) **OSTRZEŻENIE** - Wysokie łózka i górne rózko łózek piętrowych nie są odpowiednie dla dzieci poniżej sześciu lat ze względu na ryzyko obrażeń w wyniku upadku;
- b) **OSTRZEŻENIE** - Łózka piętrowe i wysokie łózka mogą stwarzać poważne ryzyko obrażeń na skutek uduszenia, jeśli nie zostaną właściwie użyte. Nigdy nie mocuj ani nie wieszaj przedmiotów na żadnej części łózka piętrowego, które nie są przeznaczone do użytku z łózkami, na przykład, ale nie ograniczając się do lin, sznurków, sznurków, haczyków, pasów i toreb.
- c) **OSTRZEŻENIE** - Dzieci mogą zostać uwięzione między łózkami a ścianą, nachyleniem dachu pod sufitem przylegającymi meblami (np. szafkami) i tym podobnie. Aby uniknąć ryzyka poważnych obrażeń, odległość między górną barierą bezpieczeństwa a przylegającą konstrukcją nie może przekraczać 75 mm lub być większa niż 230 mm.
- d) **OSTRZEŻENIE** - Nie używaj łózka piętrowego / wysokiego łózka, jeśli jakkolwiek część konstrukcyjna jest zepsuta lub brakuje jej; Części zamienné są wymagane od producenta lub sklepu.
- e) bezwzględnie należy przestrzegać instrukcji instalacji i użytkowania producenta.
- f) Zalecany rozmiar materaca do zastosowania z łózkami to 200 cm x140cm, maksymalna grubość materaca: 10 cm.
- g) Konieczna jest wentylacja pomieszczenia w celu utrzymania niskiego poziomu wilgoci i zapobiegania rozwojowi pleśni w łózkach i jego obrzeżach.
- h) Urządzenia łączące powinny być zawsze odpowiednio dokręcone i regularnie sprawdzane. Dokręć w razie potrzeby.
- i) **OSTRZEŻENIE** "Zawsze upewnij się, że platforma i drabina / schody są na stałe przymocowane do tego leżanka łózka przed użyciem"
- j) **OSTRZEŻENIE** "Ten produkt musi być przymocowany do ściany lub konstrukcji budynku"

INSTRUKCE

DŮLEŽITÉ - PŘEČTĚTE SI POZORNĚ - UCHOVÁVAJTE PRO BUDOUCÍ REFERENCE

- a) **VAROVÁNÍ** - vysoké postele a horní lóžka palandy nejsou vhodné pro děti do šesti let z důvodu rizika zranění pádem;
- b) **VAROVÁNÍ** - Patrové postele a vysoké postele mohou představovat vážné riziko zranění při uškrcení, pokud nebudou správně použity. Nikdy nepřipevňujte ani nezávěšujte předměty na žádnou část palandy, které nejsou navrženy pro použití s postelí, ale neomezuji se pouze na lana, provázky, šnůry, háčky, pásy a tašky.
- c) **VÝSTRAHA** - Děti se mohou zachytit mezi postelí a zeď, sklonit střechu stropu přilehlé kusy nábytku (např. skříňe) a podobně. Aby se zabránilo riziku vážného zranění, nesmí vzdálenost mezi horní bezpečnostní bariérou a sousední konstrukcí překročit 75 mm nebo být větší než 230 mm.
- d) **VÝSTRAHA** - Nepoužívejte patrové lóžka / vysoké lóžka, pokud je některá konstrukční část zlomená nebo chybí; Náhradní díly jsou mezi na vyžádání od výrobce nebo obchodu.
- e) je bezpodmínečně nutné dodržovat instalační pokyny a použití výrobcem.
- f) Doporučená velikost matrace pro použití s postelí je 200 cm x140cm, maximální tloušťka matrace: 10 cm.
- g) Místnost je nutné ventilovat, aby se udržela nízká hladina vlhkosti a zabránilo se růstu plísní v loži a jeho obvodu.
- h) Spojovací zařízení by měla být vždy pevně dotažena a pravidelně ověřována. V případě potřeby dotáhněte.
- i) **VAROVÁNÍ** - "Vždy se ujistěte, že plošina a Zebliik / schody jsou trvale připevněny k této palandě před použitím uložte"
- j) **VAROVÁNÍ** - "Tento výrobek musí být připevněn ke zdi nebo stavební konstrukci"

INŠTRUKCIE

DŮLEŽITÉ - POZORNE SI PREČÍTAJTE - UCHOVÁVAJTE PRE BUDÚCE REFERENCIE

- a) **VÝSTRAHA** - Vysoké postele a horné postele poschodových postelí nie sú vhodné pre deti do šiestich rokov kvôli riziku zranenia pádom;
- b) **VÝSTRAHA** - poschodové postele a vysoké postele môžu predstavovať vážne riziko zranenia priškrtením, ak sa nebudú správne používať. Nikdy nepřipevňujte ani nezávěšajte předměty k žádné části poschodové postele, která nie je určená na použitie s postelou, například, ale nielen, lana, šnůry, šnůry, háčky, pásy a tašky.
- c) **VÝSTRAHA** - Deti sa môžu zachytiť medzi postelou a stenou, sklonom strechy, stropom prílehlými kusy nábytku (napr. skrinky) a podobne. Aby sa predišlo riziku vážného zranenia, vzdialenosť medzi hornou bezpečnostnou bariérou a príľahlou konštrukciou nesmie prekročiť 75 mm alebo byť viac ako 230 mm.
- d) **VÝSTRAHA** - Nepoužívajte poschodovú posteľ / vysoké lóžko, ak je akákoľvek konštrukčná časť poškodená alebo chýba; Náhradné diely sú potrebné na vyžiadanie od výrobcu alebo skladu.
- e) je bezpodmínečně nutné postupovať podľa pokynov na inštaláciu a podľa pokynov výrobcu.
- f) Doporučená veľkosť matrace použitého na lóžko je 200 cm x140cm, maximálna hrúbka matrace: 10 cm.
- g) Miestnosť je potrebné vetrať, aby sa udržala nízka úroveň vlhkosti a zabránilo sa rastu plesní v lóžku a jeho obvode.
- h) Spojovacie zariadenia by sa mali vždy pevne dotiahnuť a pravidelne preverovať. V prípade potreby dotiahnite.
- i) **VÝSTRAHA** - "Vždy sa uistite, že plošina a rebrík/schody sú trvalo pripevnené k tomuto lóžku lóžko pred použitím"
- j) **VÝSTRAHA** - "Tento výrobok musí byť pripevný k stene alebo stavebnej konštrukcii"

UTASÍTÁS

FONTOS - OLVASSA EL FIGYELMESEN - VÁRJON A

JÖVŐBEN

- a) **VIGYÁZAT** - A magas ágyak és az emeletes ágyak felső ágya nem alkalmas hat év alatti gyermekek számára az esések sérülésének veszélye miatt;
- b) **FIGYELMEZTETÉS** - Az emeletes ágyak és a magas ágyak súlyos sérülést okozhatnak a fojtogatás következtében, ha nem használják helyesen. Soha ne csatlakoztasson és ne lógjon az emeletes ágy olyan részeire, amelyeket például nem az ágyhoz való felhasználásra terveztek, de ezekre nem korlátozódnak: kötelek, hurok, zsinórok, horgok, övek és táskák.
- c) **FIGYELMEZTETÉS** - A gyermekek becsapódhatnak az ágy és a fal közé, tetőtéri a mennyezetet a szomszédos bútorokhoz (például szekrényekhez) és hasonlókat. A súlyos sérülés kockázatának elkerülése érdekében a felső biztonsági akadály és a szomszédos szerkezet közötti távolság nem haladhatja meg a 75 mm-t vagy több, mint 230 mm.
- d) **FIGYELMEZTETÉS** - Ne használja az emeletes ágyat / magas ágyat, ha valamelyik szerkezeti elem törött vagy hiányzik; A cserealkatrészeket a gyártótól vagy a bolttól kérheti.
- e) feltétlenül kövesse a telepítési utasításokat és a gyártó általi felhasználást.
- f) Az ágyhoz használni kívánt matrac ajánlott mérete 200 cm x140cm, a matrac maximális vastagsága: 10 cm.
- g) Szellőztetni kell a helyiséget, hogy fennmaradjon az alacsony nedvességtartalom, és megakadályozzák a penész növekedését az ágyban és annak peremén.
- h) A csatlakozóberendezéseket mindig megfelelően meg kell húzni és rendszeresen ellenőrizni kell. Szükség esetén húzza meg.
- i) **FIGYELMEZTETÉS** - "Mindig győződjön meg arról, hogy a platform és a létra / lépcső Állandóan ehhez az Ágyhoz van rögzítve Ágy használat előtt!"
- j) "Ezt a terméket falhoz vagy épületszerkezethez kell rögzíteni!"

INSTRUCȚIUNI

IMPORTANT - CITIȚI CU ATENȚIE - PĂȚIȚI PENTRU

REFERINȚĂ VIITORĂ

- a) **AVERTIZARE** - Paturile înalte și patul superior al paturilor nu sunt potrivite pentru copiii sub șase ani din cauza riscului de rănire din cauza căderilor;
- b) **AVERTIZARE** - Paturile suprapuse și paturile înalte pot prezenta un risc grav de rănire din cauza strangulării dacă nu sunt utilizate corect. Nu atașați și nu agățați niciodată articole pe nicio parte a patului care nu sunt concepute pentru a fi utilizate cu patul, de exemplu, dar fără a se limita la frânghii, corzi, șnururi, cârlige, curele și saci.
- c) **AVERTIZARE** - Copiii pot deveni prinși între pat și perete, pot acoperi acoperișul pe piesele de mobilier alăturate (de ex. dulapuri) și altele asemenea. Pentru a evita riscul de rănire gravă, distanța dintre bariera de siguranță superioară și structura alăturată nu trebuie să depășească 75 mm sau să fie mai mare de 230 mm.
- d) **AVERTIZARE** - Nu folosiți patul supraetajat / patul înalt dacă o parte structurală este ruptă sau lipsește; Piesele de schimb se fac între solicitarea producătorului sau a magazinului.
- e) este obligatoriu să respectați întotdeauna instrucțiunile de instalare și utilizarea producătorului.
- f) Dimensiunea recomandată a saltelei care va fi folosită cu patul este de 200cm x140cm, grosimea maximă a saltelei:10cm.
- g) Este necesară ventilarea camerei pentru a menține o umiditate la nivel scăzut și a preveni creșterea mușgaiului în pat și la periferia acesteia.
- h) Dispozitivele de îmbinare trebuie întinse întotdeauna corect și verificate regulat. Strângeți dacă este necesar.
- i) **AVERTIZARE** - "Asigurați-vă întotdeauna că platforma și scara / scările sunt atașate permanent la acest pat înainte de utilizare!"
- j) **AVERTIZARE** - "Acest produs trebuie atașat la un perete sau la o structură a clădirii!"

TALÍMATLAR

ÖNEMLİ - DİKKATLE OKUYUN - GELECEK REFERANS

İÇİN TUTUN

- a) **UYARI** - Yüksek yataklar ve ranzaların üst yatağı, düşme nedeniyle yaralanma tehlikesi nedeniyle altı yaşın altındaki çocuklar için uygun değildir;
- b) **UYARI** - Ranzalar ve yüksek yataklar, doğru kullanılmadığı takdirde boğulma nedeniyle ciddi yaralanma riski oluşturabilir. Hiçbir zaman ranza yatağının, yatakla birlikte kullanılmak üzere tasarlanmamış, ancak ipler, ipler, kordonlar, kancalar, kayışlar ve çantalar ile sınırlı olmamak üzere herhangi bir parçasına takmayın veya asılmayın.
- c) **UYARI** - Çocuklar yatakla duvar arasında sıkışıp kalabilir, tavana bitişik mobilya parçaları (örneğin dolaplar) ve benzeri bir tavan döşenir. Ciddi yaralanma riskini önlemek için üst güvenlik bariyeri ve bitişik yapı arasındaki mesafe 75 mm'yi geçmemelidir veya 230 mm'den fazla olmalıdır.
- d) **UYARI** - Herhangi bir yapısal parça kırılmış veya eksikse ranza / yüksek yatak kullanmayın; Yedek parçalar üretici veya mağazadan talep arasındadır.
- e) her zaman kurulum talimatlarını ve üreticinin kullanımını takip etmek zorunludur.
- f) Yatak ile birlikte kullanılması tavsiye edilen yatak boyutu 200 cm x140cm, maksimum kalınlık yatağı: 10 cm'dir.
- g) Düşük seviyede nem sağlamak ve yatak ve çevresinde küf oluşumunu önlemek için odanın havalandırılması gerekir.
- h) Birleştirme cihazları her zaman uygun şekilde sıkılmalı ve düzenli olarak kontrol edilmelidir. Gerekirse sıkın.
- i) **UYARI** - "Her zaman platformun ve merdivenin / merdivenlerin bu ranzaya kalıcı olarak bağlı olduğundan emin olun kullanmadan önce yatak!"
- j) **UYARI** - "Bu ürün bir duvara veya bina yapısına takılmamalıdır"

ИНСТРУКЦИИ

ВАЖНО - ПРОЧИТАЙТЕ ВНИМАТЕЛЬНО - СОХРАНИТЕ БУДУЩУЮ ССЫЛКУ

- a) **ПРЕДУПРЕЖДЕНИЕ** - Высокие кровати и верхняя кровать двухъярусных кроватей не подходят для детей младше шести лет из-за риска получения травмы в результате падения;
- b) **ПРЕДУПРЕЖДЕНИЕ** - двухъярусные кровати и высокие кровати могут представлять серьезную опасность травмирования от удушья, если их неправильно использовать. Никогда не прикрепляйте и не подвешивайте предметы к какой-либо части двухъярусной кровати, например, которые не предназначены для использования с кроватью, но не ограничиваются веревками, веревками, шнурами, крчжками, ремнями и сумками.
- c) **ПРЕДУПРЕЖДЕНИЕ** - Дети могут оказаться в ловушке между кроватью и стеной, крышей, наклонить потолок к смежным предметам мебели (например, шкафом) и т.д. Во избежание риска получения серьезных травм расстояние между верхним защитным барьером и прилегающей конструкцией не должно превышать 75 мм или должно быть более 230 мм.
- d) **ПРЕДУПРЕЖДЕНИЕ** - не используйте двухъярусную кровать / высокую кровать, если какая-либо конструктивная часть сломана или отсутствует; Запасные части между запросами от производителя или магазина.
- e) обязательно всегда следовать инструкциям по установке и использованию изготовителем.
- f) Рекомендуемый размер матраса, который будет использоваться с кроватью, составляет 200 см x140см, максимальная толщина матраса:10 см.
- g) Необходимо проветривать помещение, чтобы поддерживать низкий уровень влаги и предотвращать образование плесени в ложе и на его периферии.
- h) Соединительные устройства всегда должны быть надежно затянуты и регулярно проверяться. Затянуть при необходимости.
- i) **ПРЕДУПРЕЖДЕНИЕ** - "Всегда убедитесь, что платформа и лестница/лес-Тница ПОСТОЯННО прикреплены К ЭТОЙ КОЙКЕ Кровати перед использованием!"
- j) **ПРЕДУПРЕЖДЕНИЕ** - "этот продукт должен быть прикреплен к стене или строительной конструкции"

English

IMPORTANT ! KEEP FOR FUTURE REFERENCE : READ CAREFULLY

- To be assembled by an adult. Assembly must be checked by an adult before use
- **WARNING !** Keep all screws, small parts and plastic bags out of the reach of children
- Properly identify all parts before assembling
- Never use your item if any of its parts are broken or missing
- Should any problems arise, please contact our After Sales Service
- Manufacturer's instructions shall be followed at all times
- Care: Clean with a soft, dry cloth. In case of larger stains, carefully rub with a slightly damp, non-abrasive sponge
- Avoid the risk of fire by not placing furniture near sources of ignition or hot items
- Do not jump on the bed

Deutsch

WICHTIG ! ZUM SPÄTEREN NACHSCHLAGEN AUFBEWAHREN: SORGFÄLTIG LESEN

- Muss von einem Erwachsenen zusammengebaut werden. Der Zusammenbau muss vor dem Gebrauch von einem Erwachsenen überprüft werden
- **WARNUNG!** Bewahren Sie alle Schrauben, Kleinteile und Plastikbeutel außerhalb der Reichweite von Kindern auf
- Kennzeichnen Sie vor dem Zusammenbau alle Teile richtig
- Benutzen Sie Ihren Artikel niemals, wenn Teile gebrochen sind oder fehlen
- Sollten Probleme auftreten, wenden Sie sich bitte an unseren Kundendienst
- Die Anweisungen des Herstellers sind stets zu befolgen
- Pflege: Mit einem weichen, trockenen Tuch reinigen. Bei größeren Flecken vorsichtig mit einem leicht feuchten, nicht scheuernden Schwamm abreiben. nicht scheuernden Schwamm
- Vermeiden Sie die Gefahr eines Brandes, indem Sie die Möbel nicht in der Nähe von Zündquellen oder heißen Gegenständen aufstellen
- Nicht auf das Bett springen

Français

IMPORTANT ! CONSERVER POUR RÉFÉRENCE ULTÉRIEURE : LIRE ATTENTIVEMENT

- Le montage doit être effectué par un adulte. Le montage doit être vérifié par un adulte avant Utilisation
- **ATTENTION !** Tenir les vis, les petites pièces et les sachets en plastique hors de portée des enfants
- Identifiez correctement toutes les pièces avant de les assembler
- N'utilisez jamais votre article si l'une de ses pièces est cassée ou manquante
- En cas de problème, veuillez contacter notre service après-vente
- Les instructions du fabricant doivent être respectées à tout moment
- Entretien : nettoyer avec un chiffon doux et sec. En cas de taches plus importantes, frotter soigneusement avec une éponge non abrasive légèrement humide. légèrement humide et non Abrasive
- Évitez les risques d'incendie en ne plaçant pas les meubles à proximité de sources d'inflammation ou d'objets chauds
- Ne pas sauter sur le lit

Italiano

IMPORTANTE! CONSERVARE PER RIFERIMENTO FUTURO: LEGGERE ATTENTAMENTE

- Deve essere assemblato da un adulto. L'assemblaggio deve essere controllato da un adulto prima dell'uso
- **ATTENZIONE!** Tenere tutte le viti, le piccole parti e i sacchetti di plastica fuori dalla portata dei bambini
- Identificare correttamente tutte le parti prima dell'assemblaggio
- Non utilizzare mai l'articolo se alcune parti sono rotte o mancanti
- In caso di problemi, si prega di contattare il nostro Servizio Post Vendita
- Le istruzioni del produttore devono essere sempre seguite
- Cura: Pulire con un panno morbido e asciutto. In caso di macchie più estese, strofinare accuratamente con una spugna leggermente umida e non abrasiva
- Evitare il rischio di incendio, non collocando i mobili vicino a fonti di accensione o a oggetti caldi
- Non saltare sul letto

Español

¡ IMPORTANTE ! CONSERVELO PARA FUTURAS CONSULTAS: LEA ATENTAMENTE

- Debe ser montado por un adulto. El montaje debe ser comprobado por un adulto antes del uso
- ADVERTENCIA** Mantenga todos los tornillos, piezas pequeñas y bolsas de plástico fuera del alcance de los niños.
- Identifique correctamente todas las piezas antes de montarlas
 - Nunca utilice su artículo si alguna de sus piezas está rota o falta
 - Si surge algún problema, póngase en contacto con nuestro Servicio Postventa
 - Las instrucciones del fabricante deben seguirse en todo momento
 - Cuidado: Limpiar con un paño suave y seco. En caso de manchas más grandes, frote cuidadosamente con una esponja no abrasiva ligeramente humedecida.
 - Evite el riesgo de incendio no colocando los muebles cerca de fuentes de ignición u objetos calientes.
 - No saltar sobre la cama.

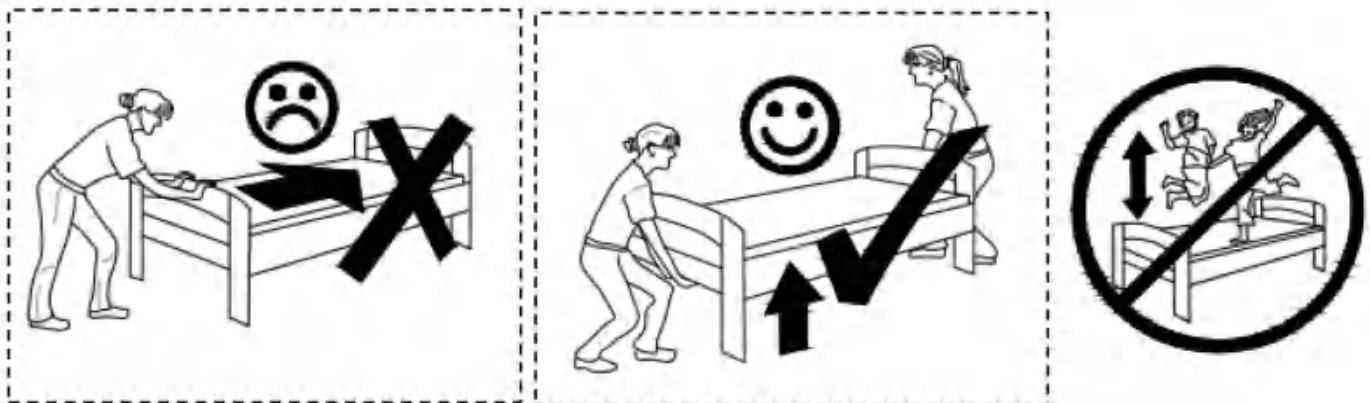

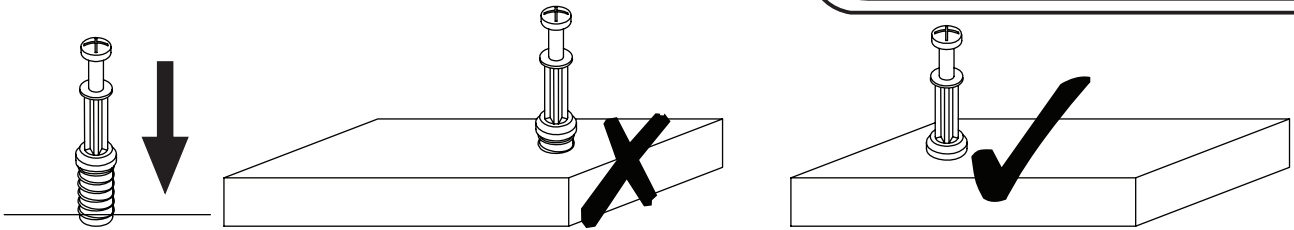

EN_QUICKFIT: Tighten quickfit until shoulder is flush with panel. Do not overtighten or undertighten.

FR_RACCORD RAPIDE: Faites serrer le raccord rapide jusqu'à ce que l'épaulement soit parfaitement encastré dans le panneau. Il ne faut ni trop serrer ni insuffisamment serrer.

ES_QUICKFIT: Apriete quickfit hasta que el hombro se descargue con el panel. NO lo sobreapriete ni lo apriete poco.

DE_QUICKFIT: Ziehen Sie den Quickfit fest, bis die Schulter mit der Platte bündig ist. Bitte nicht zu fest oder zu schwach anziehen.

IT_MONTAGGIO RAPIDO: Stringere il montaggio rapido fino a quando la spalla è a filo con il pannello, non stringere troppo o troppo poco.

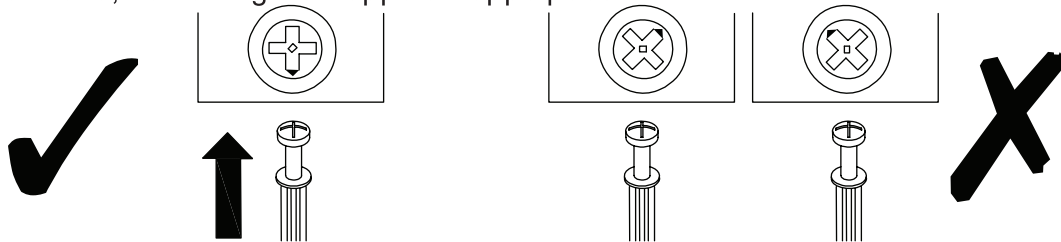

EN_CAM LOCK: When fitting cam lock, ensure starting position is correct before you insert connecting quickfit.

FR_SERRURE BATTEUSE: Avant d'insérer la serrure batteuse, veillez à la bonne orientation avant d'insérer le raccord rapide.

ES_CIERRE DE LA CÁMARA: Cuando instale el cierre de la cámara, asegúrese de que la posición de inicio es correcta antes de que inserte el quickfit conector.

DE_CAM-LOCK: Achten Sie bei der Montage des Cam-Locks auf die richtige Ausgangsposition, bevor Sie den Quickfit einsetzen.

IT_BLOCCAGGIO A CAMMA: Quando si monta il bloccaggio a camma, assicurarsi che la posizione iniziale sia corretta prima di inserire il montaggio rapido di collegamento.

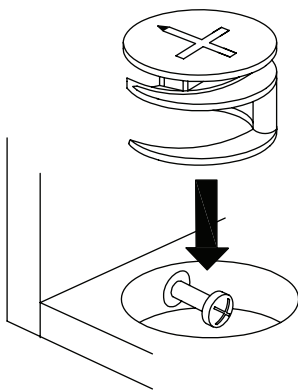

EN_Quickfit head should be in the centre of the cam lock when the two panels are joined.

Cam lock should be inserted before quickfit.

FR_Lorsque les deux panneaux sont assemblés, la tête du raccord rapide doit reposer au centre de la serrure batteuse. Il faut insérer la serrure batteuse avant le raccord rapide.

ES_El cabezal del quickfit debe estar en el centro del cierre de la cámara cuando se unan los dos paneles.

Se debe insertar el cierre de la cámara antes que el quickfit.

DE_Der Quickfit-Kopf sollte sich in der Mitte des Cam-Locks befinden, wenn die beiden Platten zusammengefügt sind. Der Cam-Lock sollte vor dem Quickfit eingesetzt werden.

IT_La testa del montaggio rapido deve trovarsi al centro del bloccaggio a camma quando i due pannelli sono uniti.

Il Bloccaggio a Camma deve essere inserito prima del montaggio rapido.

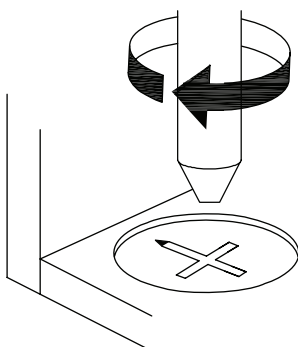

EN_Turn cam lock clockwise to tighten.

FR_Faites tourner la serrure batteuse dans le sens des aiguilles d'une montre pour la resserrer.





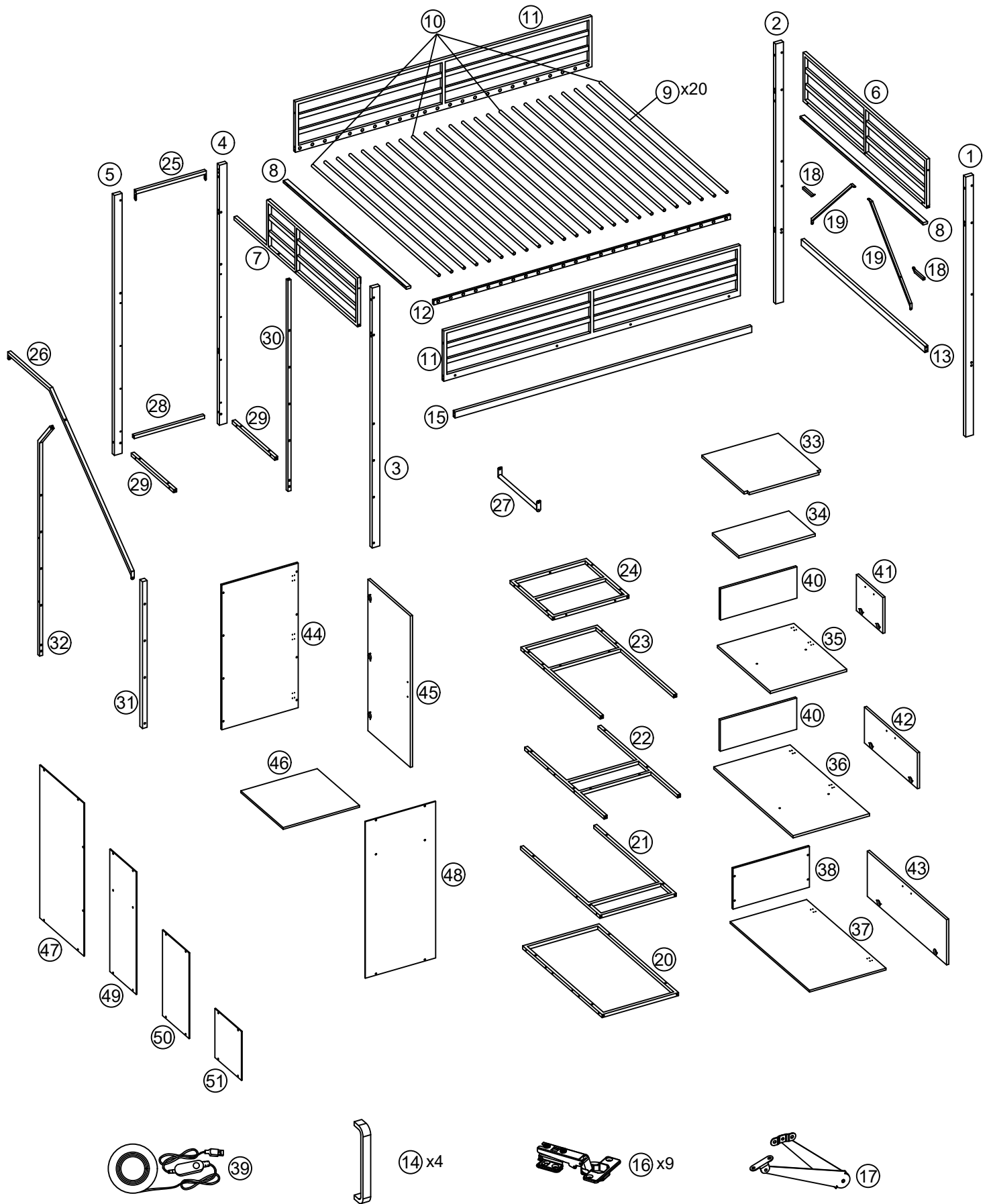

ES_Gire el cierre de la cámara en sentido horario para apretarlo.

DE_Drehen Sie den Cam-Lock im Uhrzeigersinn, um ihn festzuziehen.

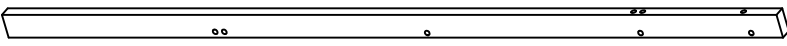
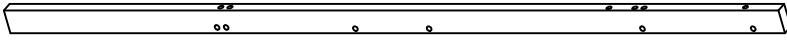
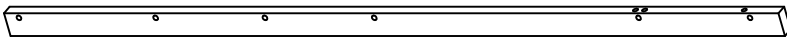
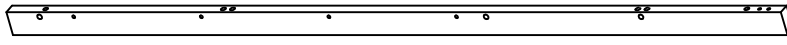
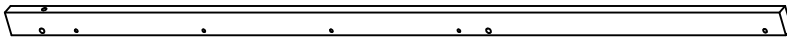
IT_Ruotare il bloccaggio a camma in senso orario per stringere.

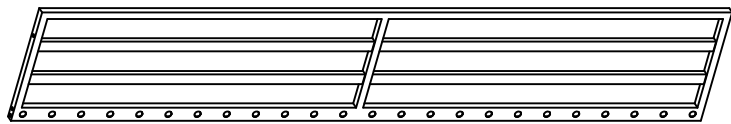
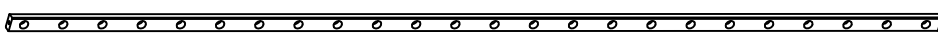
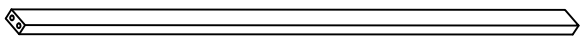
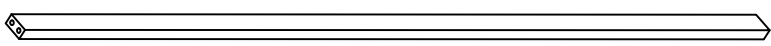
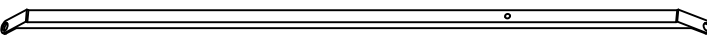

Parts List For N879P450333

①		1pc
②		1pc
③		1pc
④		1pc
⑤		1pc
⑧		2pcs
⑪		2pcs
⑫		1pc
⑬		1pc
⑮		1pc
⑱		2pcs
		2pcs
⑳		1pc
㉓		1pc
㉕		1pc

Parts List For N879P450334

⑥

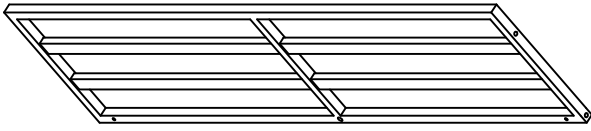

1pc

⑦

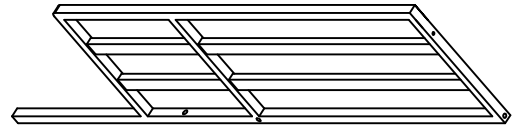

1pc

⑨

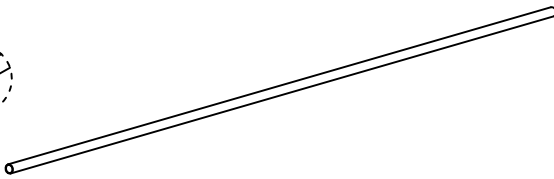

20pcs

⑩

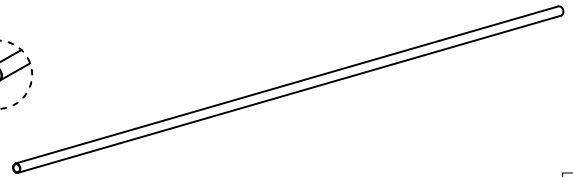

4pcs

⑭



4pcs

⑯

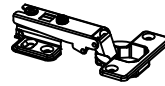

9pcs

⑰

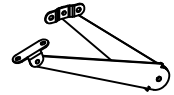

1pc

⑳

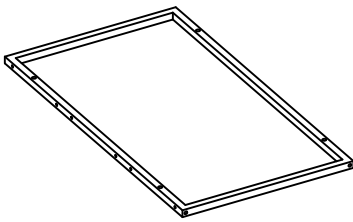

1pc

㉑

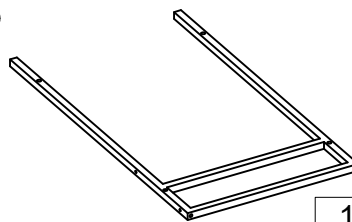

1pc

㉒

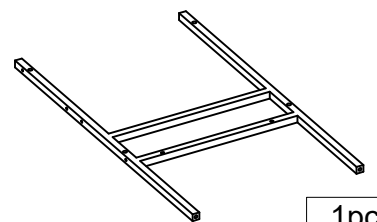

1pc

㉓

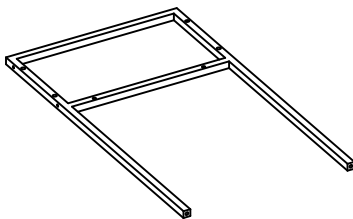

1pc

㉔

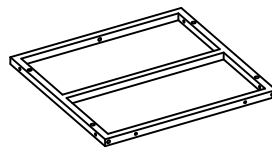

1pc

㉕



1pc

㉗

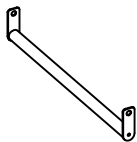

1pc

㉘

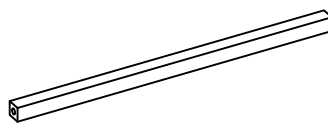

1pc

㉙

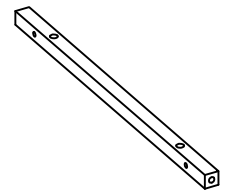

2pc

㉚



1pc

Parts List For N879P450335

33

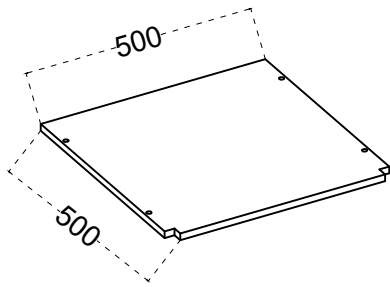

1pc

34

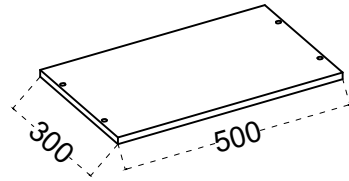

1pc

35

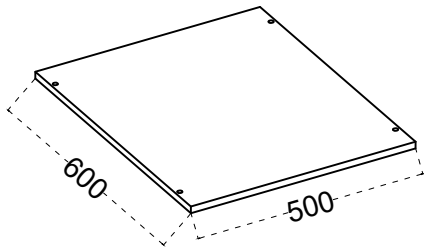

1pc

36

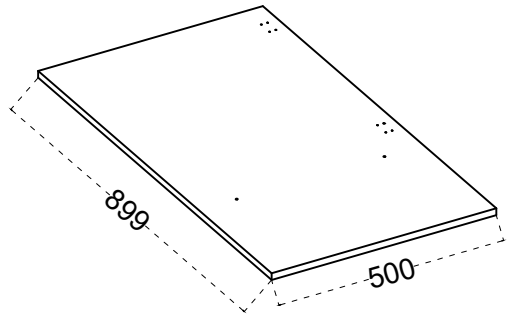

1pc

37

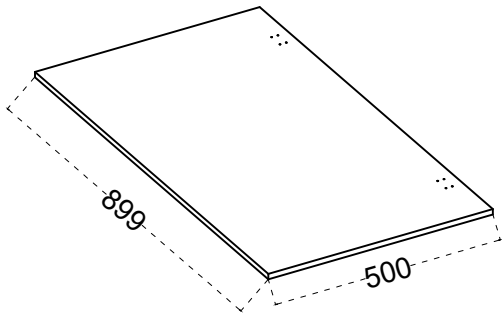

1pc

40

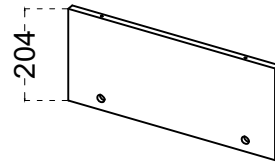

2pcs

44

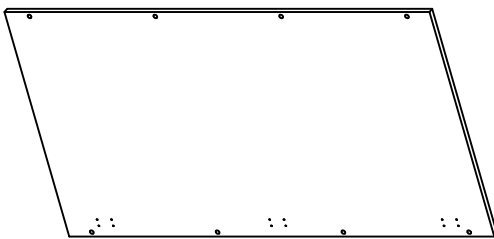

1pc

45

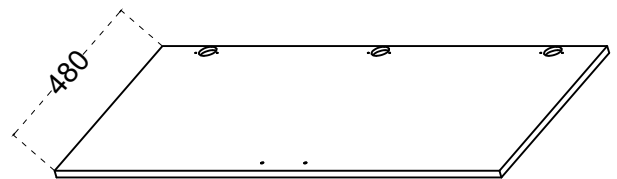

1pc

Parts List For N879P450336

31

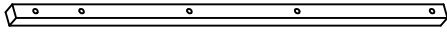

1pc

38

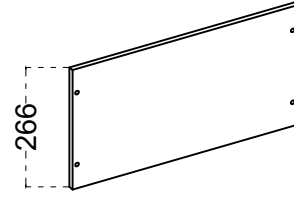

1pc

41

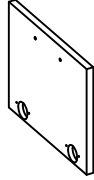

1pc

42

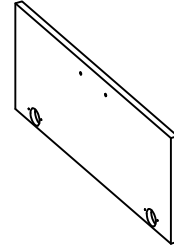

1pc

43

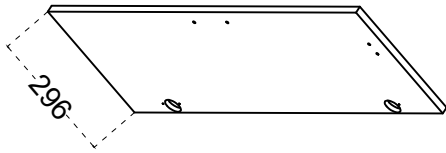

1pc

46

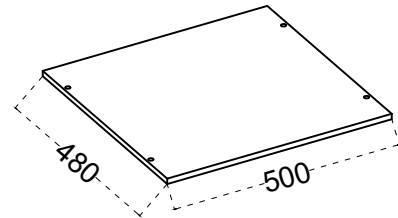

1pc

47

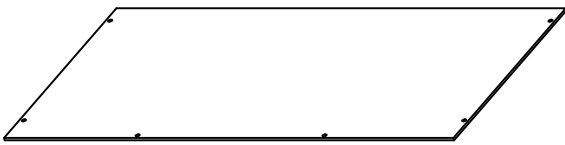

1pc

48

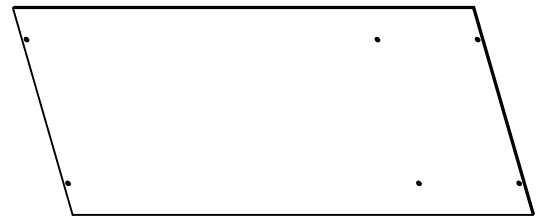

1pc

49

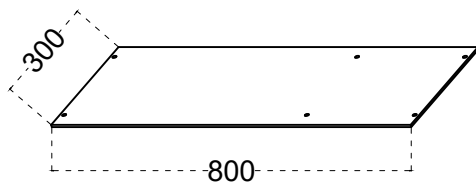

1pc

50

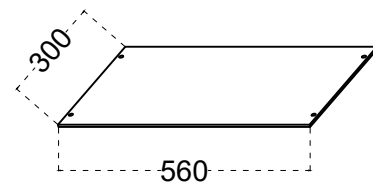





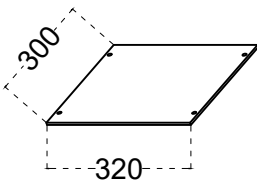





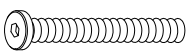
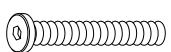
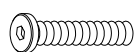
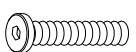

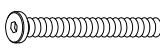
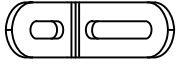
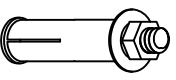





1pc

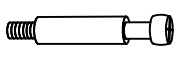

51

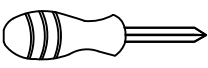

1pc

Hardware List For N879P450334

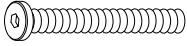
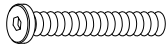
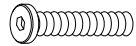
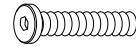
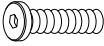

<p>(A)  M8×70mm 12pcs</p>	<p>(B)  M8×65mm 6pcs</p>	<p>(C)  M8×45mm 8pcs</p>	<p>(D)  M8×40mm 17pcs</p>
<p>(E)  M8×35mm 12pcs</p>	<p>(F)  M8×20mm 8pcs</p>	<p>(G)  M6×70mm 2pcs</p>	<p>(H)  2pcs</p>
<p>(I)  2pcs</p>	<p>(J)  1pc</p>	<p>(K)  M6×40mm 6pcs</p>	<p>(L)  M6×30mm 38pcs</p>
<p>(M)  M6×15mm 36pcs</p>	<p>(N)  M5×40mm 4pcs</p>	<p>(O)  M5×20mm 4pcs</p>	<p>(P)  M4×20mm 2pcs</p>
<p>(Q)  M4×16mm 6pcs</p>	<p>(R)  M3.5×14mm 54pcs</p>	<p>(S)  6×45mm 4pcs</p>	<p>(T)  Ø15×12mm 4pcs</p>
<p>(U)  M4 1pc</p>	<p>(V)  M5 1pc</p>	<p>(W)  1pc</p>	<p>(X)  M4×12mm 4pcs</p>
<p>(Y)  2pcs</p>			

<p>(A)</p>  <p>M8×70mm</p> <p>12pcs</p>	<p>(B)</p>  <p>M8×65mm</p> <p>6pcs</p>	<p>(C)</p>  <p>M8×45mm</p> <p>8pcs</p>	<p>(D)</p>  <p>M8×40mm</p> <p>17pcs</p>
<p>(E)</p>  <p>M8×35mm</p> <p>12pcs</p>	<p>(F)</p>  <p>M8×20mm</p> <p>8pcs</p>		

Bitte beachten Sie, dass die Formen der Schrauben A und B und C und D und E und F ähnlich sind. Bitte installieren Sie entsprechend der Anleitung und unterscheiden Sie sie!

Please note that the shapes of screws A and B and C and D and E and F are similar. Please install according to the instructions and distinguish them!

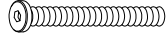
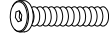

Notez que les vis A et B et C et D et E et F ont des formes similaires. Veuillez les installer en suivant les instructions pour les séparer!

<p>(G)</p>  <p>M6×70mm</p> <p>2pcs</p>	<p>(K)</p>  <p>M6×40mm</p> <p>6pcs</p>	<p>(L)</p>  <p>M6×30mm</p> <p>38pcs</p>	<p>(M)</p>  <p>M6×15mm</p> <p>36pcs</p>
---	---	---	--

Bitte beachten Sie, dass die Formen der Schrauben G und K und L und M ähnlich sind. Bitte installieren Sie entsprechend der Anleitung und unterscheiden Sie sie!

Please note that the shapes of screws G and K and L and M are similar. Please install according to the instructions and distinguish them!

Notez que les vis G et K et L et M ont des formes similaires. Veuillez les installer en suivant les instructions pour les séparer!

<p>(P)</p>  <p>M4×20mm</p> <p>2pcs</p>	<p>(Q)</p>  <p>M4×16mm</p> <p>6pcs</p>		
---	---	--	--

Bitte beachten Sie, dass die Formen der Schrauben P und Q ähnlich sind. Bitte installieren Sie entsprechend der Anleitung und unterscheiden Sie sie!

Please note that the shapes of screws P and Q are similar. Please install according to the instructions and distinguish them!

Notez que les vis P et Q ont des formes similaires. Veuillez les installer en suivant les instructions pour les séparer!

Vor dem Einbau die Schrauben in die Löcher stecken und festziehen, aber nicht bis 100%, 70% bis 80% anziehen reicht aus. Schließlich, nachdem alle Schrauben installiert sind, ziehen Sie alle Schrauben auf 100%. Wenn Sie auf diese Probleme stoßen, wie z. B. Fehlausrichtung der Löcher oder Unfähigkeit, bestimmte Teile zu installieren, überprüfen Sie bitte, ob die Schrauben korrekt verwendet werden und passen Sie die Dichtigkeit der Schrauben an.

Before installation, insert the screws into the holes and tighten them, but do not tighten them to 100%, 70% to 80% is sufficient. Finally, after all screws are installed, tighten all screws to 100%. If you encounter these issues, such as if the holes cannot be aligned or some parts cannot be installed, please check if the screws are used correctly and adjust the tightness of the screws.

Insérer la vis dans le trou avant la fin de l'assemblage, serrer la vis, mais ne pas serrer à 100%, 70% ~ 80% est correct. Enfin, une fois que toutes les vis sont bien serrées, toutes les vis sont serrées à 100%. Si vous rencontrez ces problèmes, par exemple si les trous ne sont pas alignés ou si certaines pièces ne peuvent pas être montées, vérifiez que les vis sont utilisées correctement et Ajustez leur serrage.

1

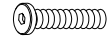

M6×40mm

(K)×4PCS



M4

(U)×1PC

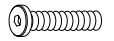
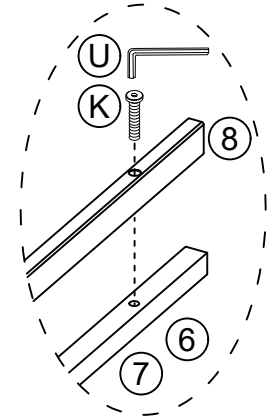
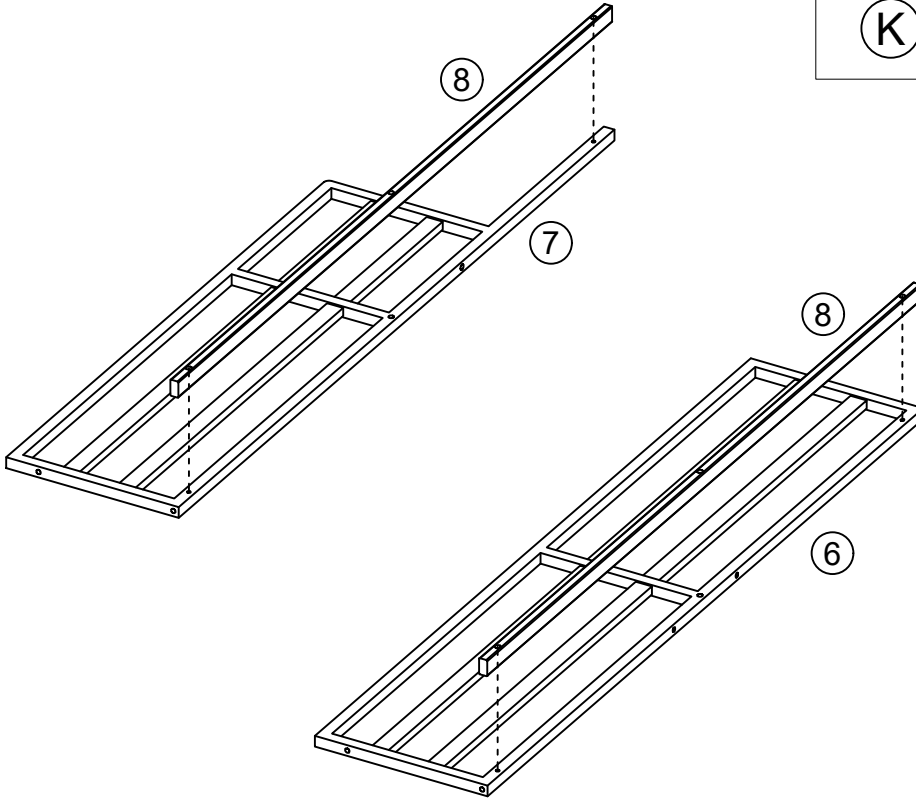

M6*40mm



M6*30mm

2

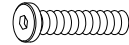

M8×40mm

(D)×3PCS



M5

(V)×1PC

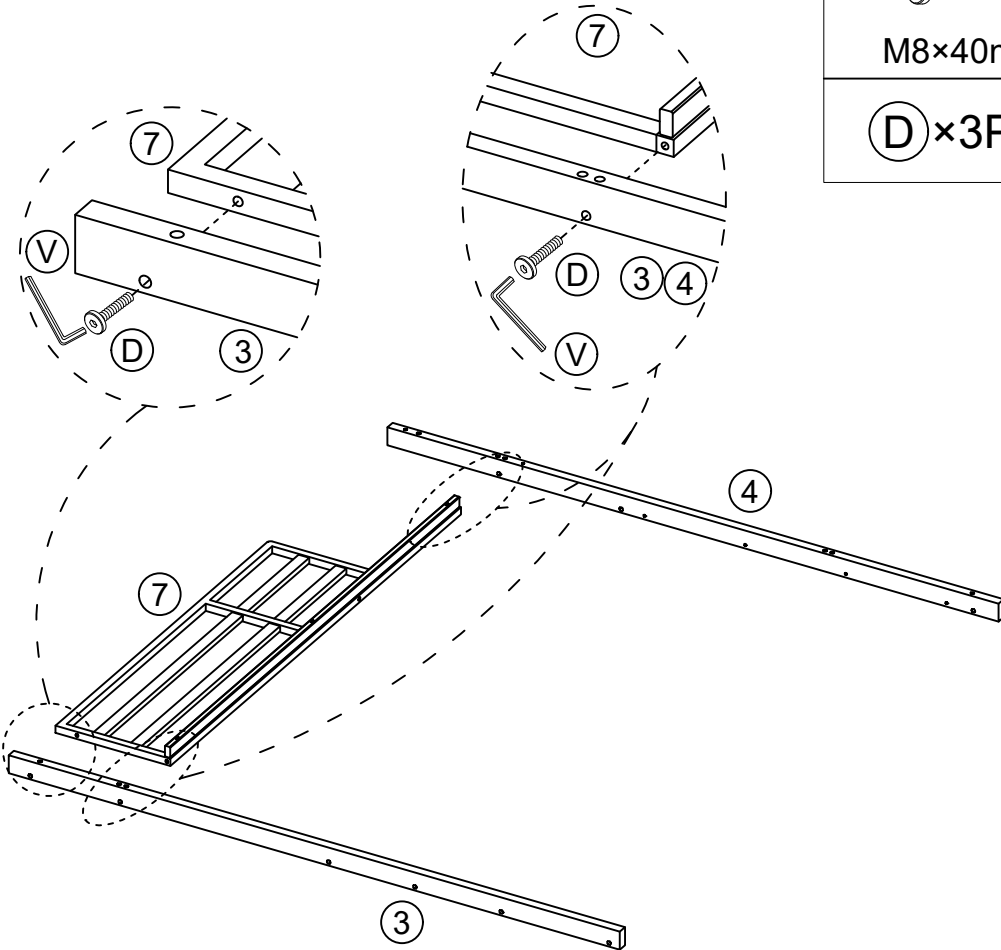



M8*40mm

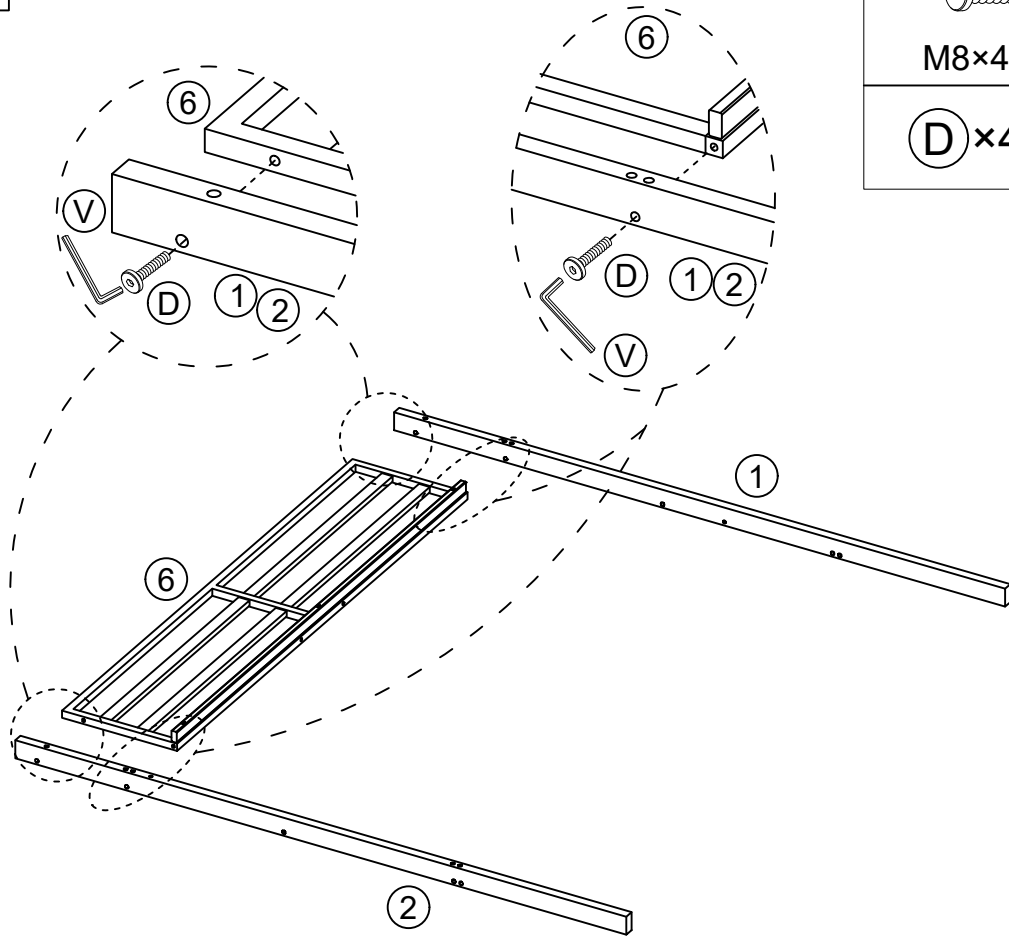

M8*35mm

3

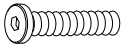
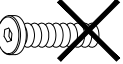

 M8×40mm	 M5
(D)×4PCS	(V)×1PC

 M8*40mm
 M8*35mm

4

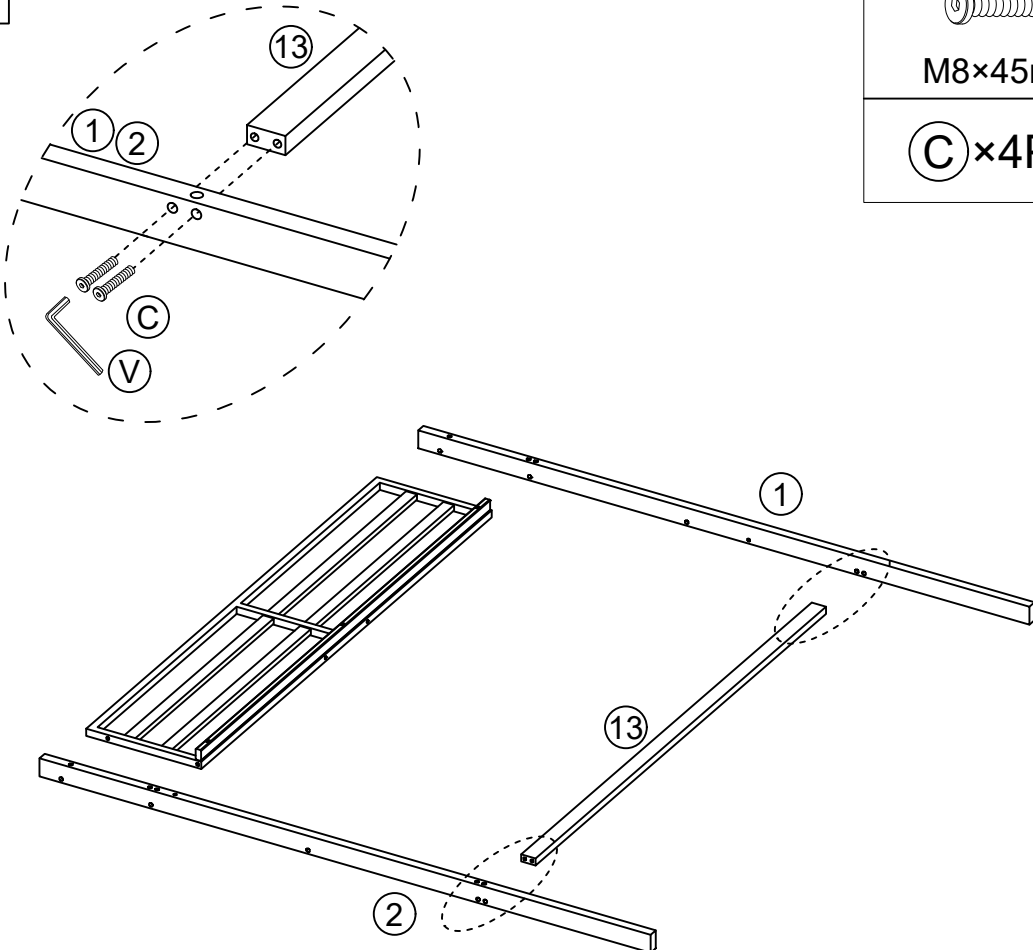

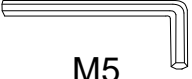

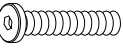
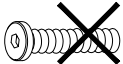
 M8×45mm	 M5
(C)×4PCS	(V)×1PC

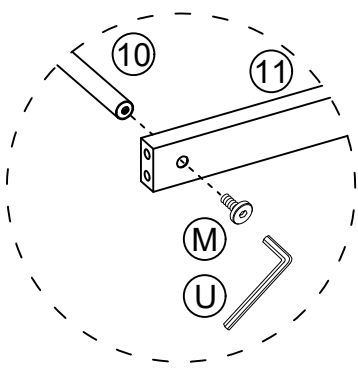

 M8*45mm
 M8*40mm

5

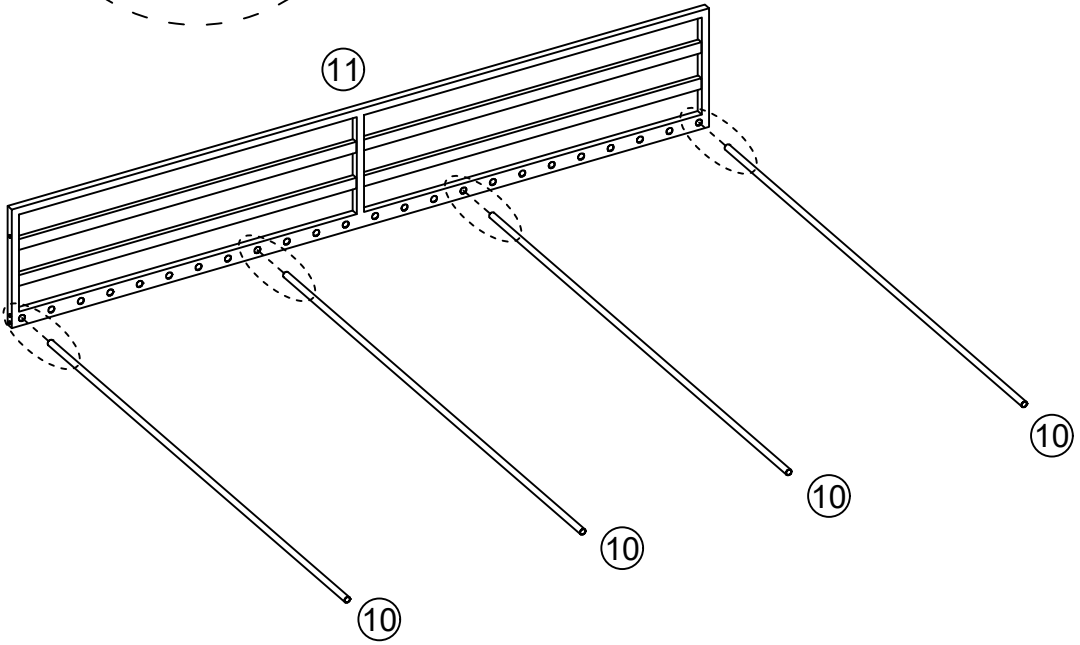

 M6*15mm	 M4
(M) × 4PCS	(U) × 1PC



 M6*15mm
 M6*30mm

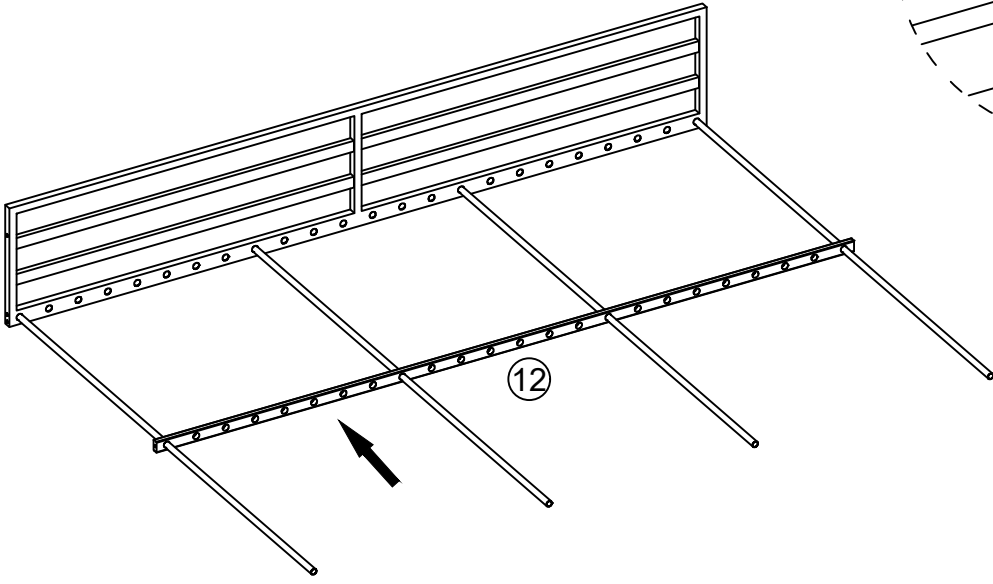
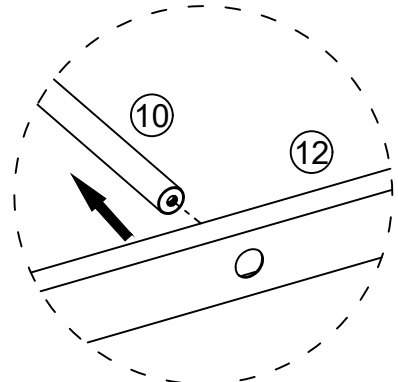

6



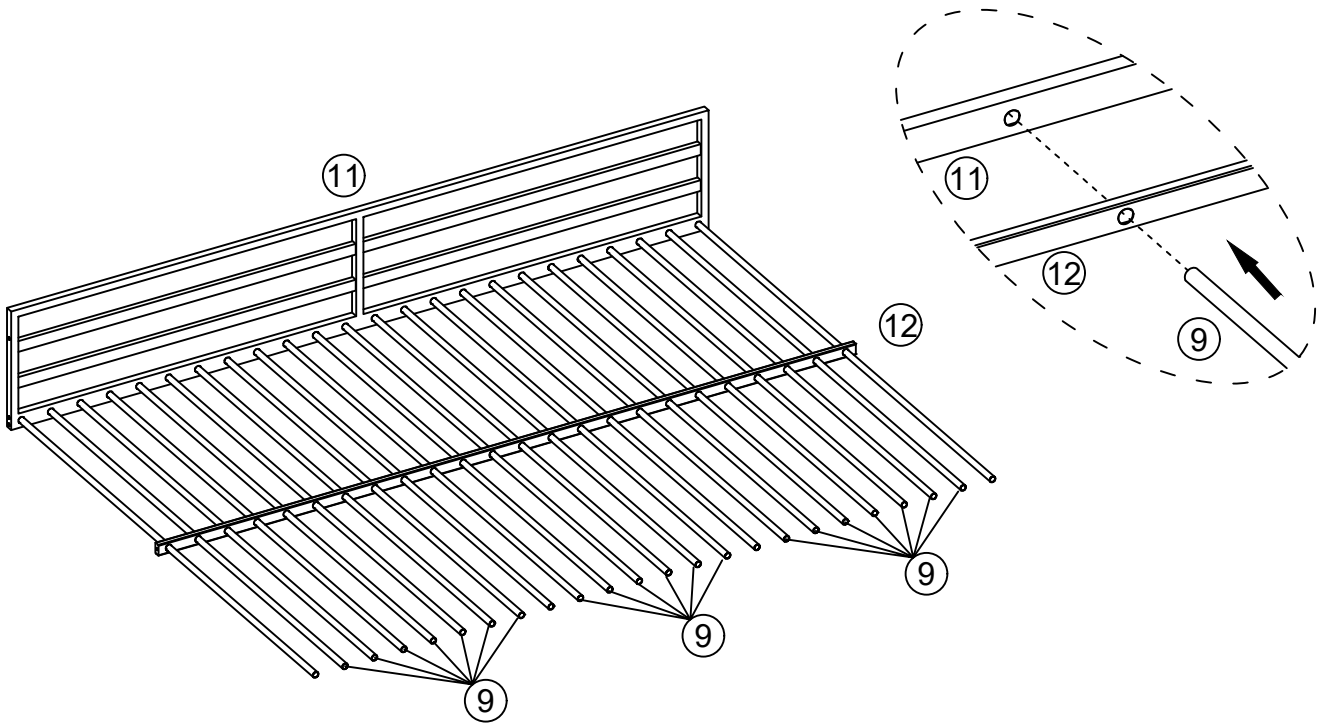

7

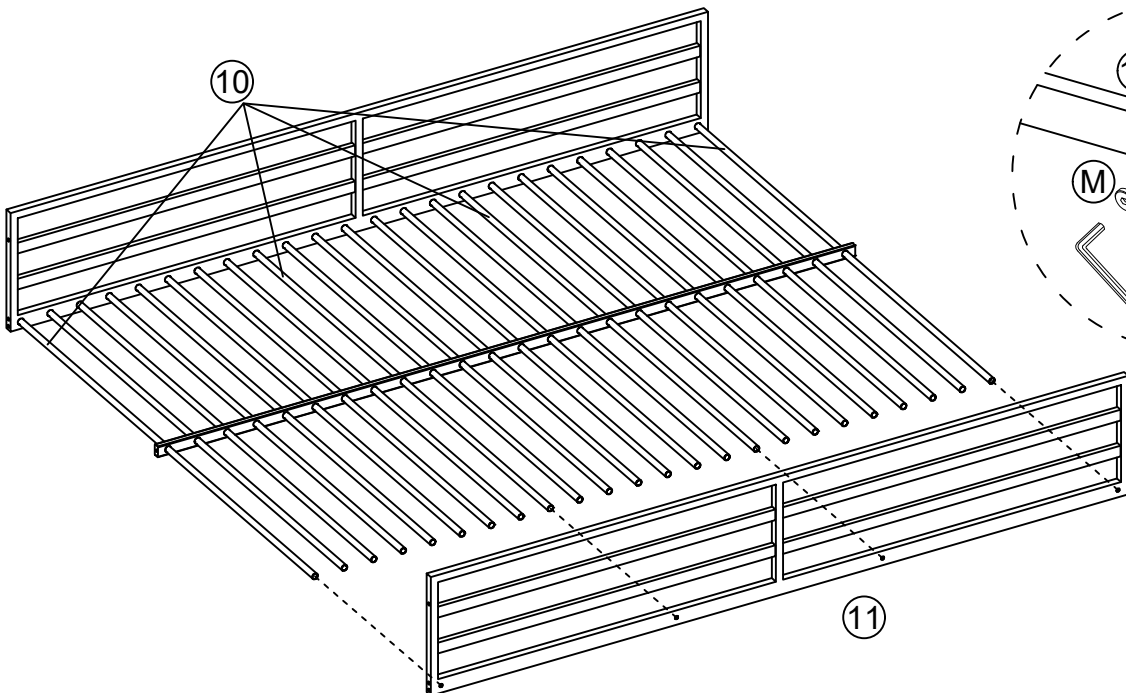

8

	
M6*15mm	M4
(M) × 4PCS	(U) × 1PC



	M6*15mm
	M6*30mm

9

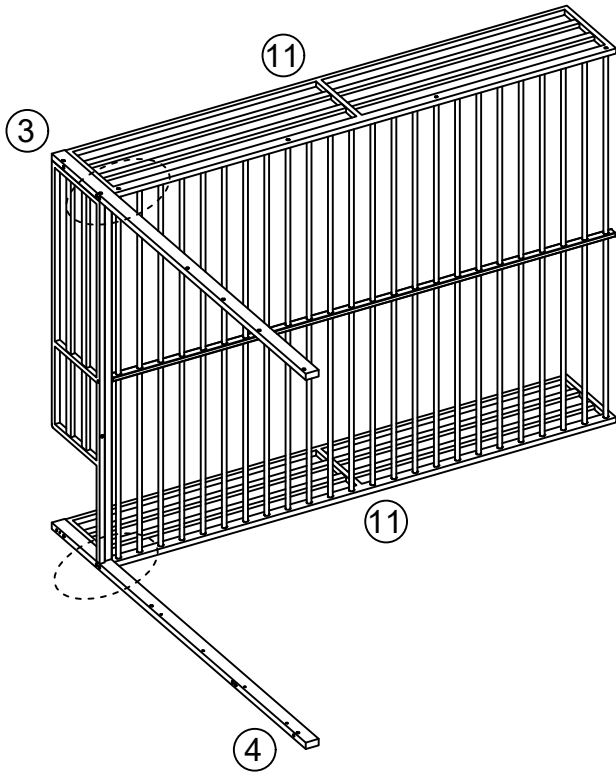

M8*70mm

(A) × 4PCS



M5

(V) × 1PC

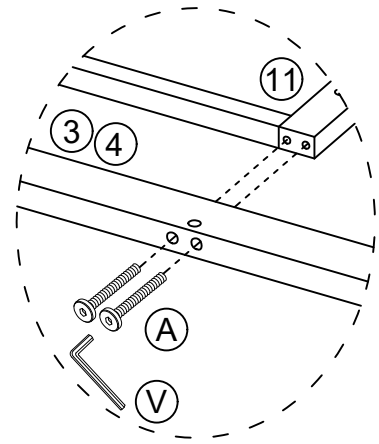

M8*70mm

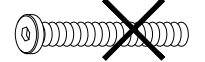

~~M8*65mm~~

10

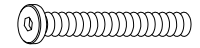
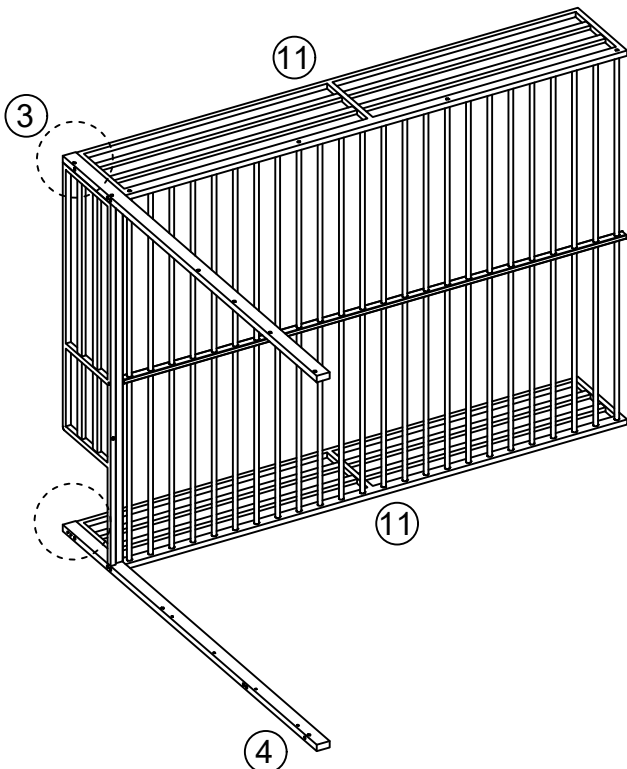

M8*65mm

(B) × 2PCS



M5

(V) × 1PC

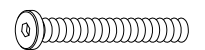
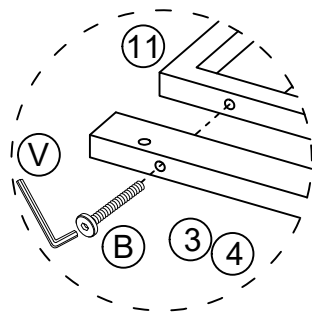

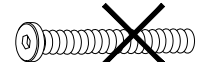

M8*65mm



~~M8*70mm~~

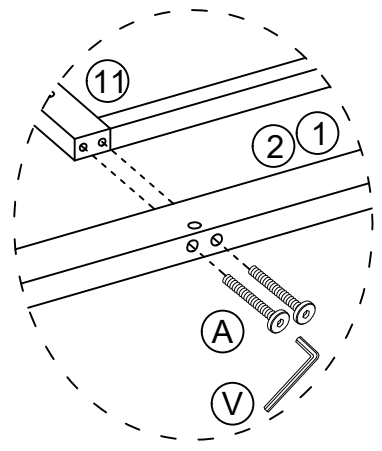
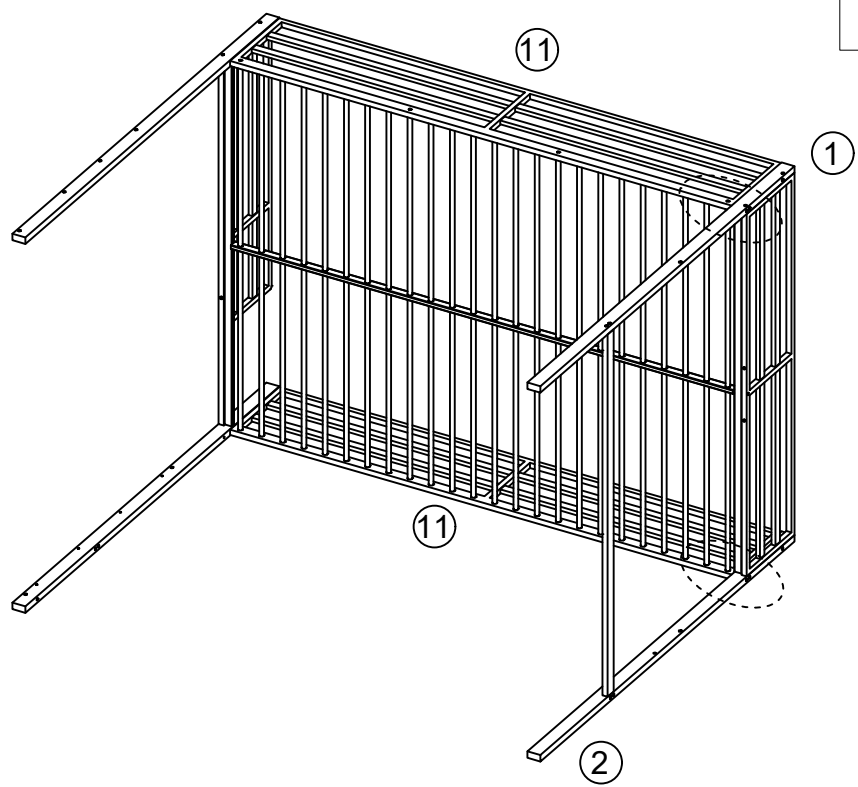

11

 M8*70mm	 M5
(A) × 4PCS	(V) × 1PC

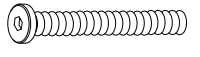
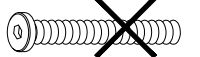

 M8*70mm
 M8*65mm

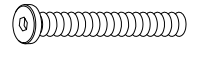
12

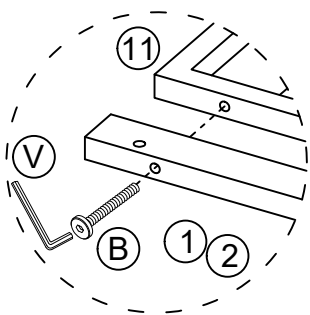
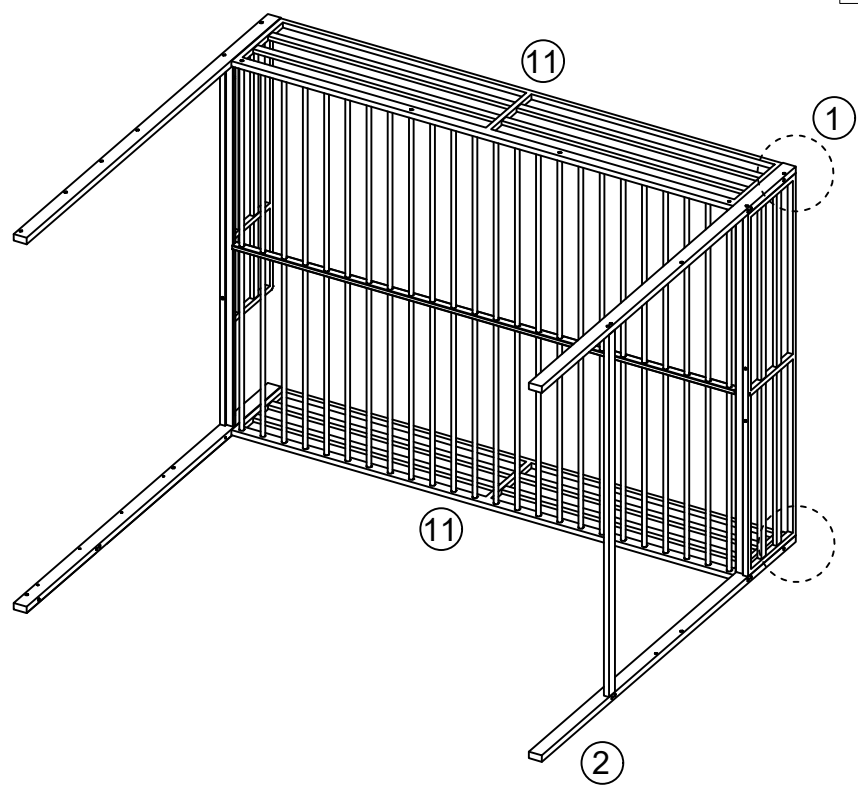

 M8*65mm	 M5
(B) × 2PCS	(V) × 1PC

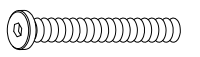
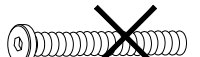

 M8*65mm
 M8*70mm

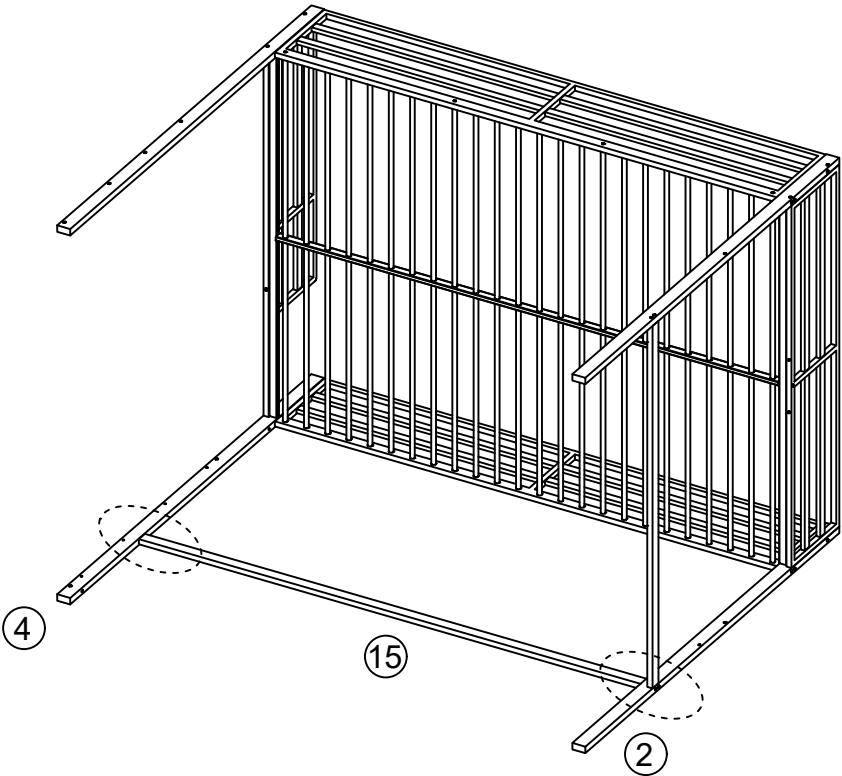
13



 M8*70mm	 M5
(A) × 4PCS	(V) × 1PC

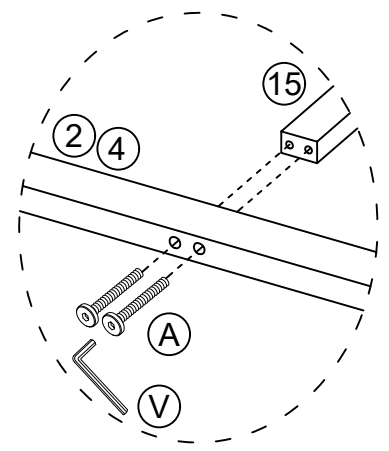

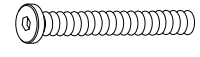
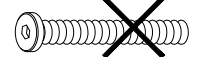
 M8*70mm
 M8*65mm

14

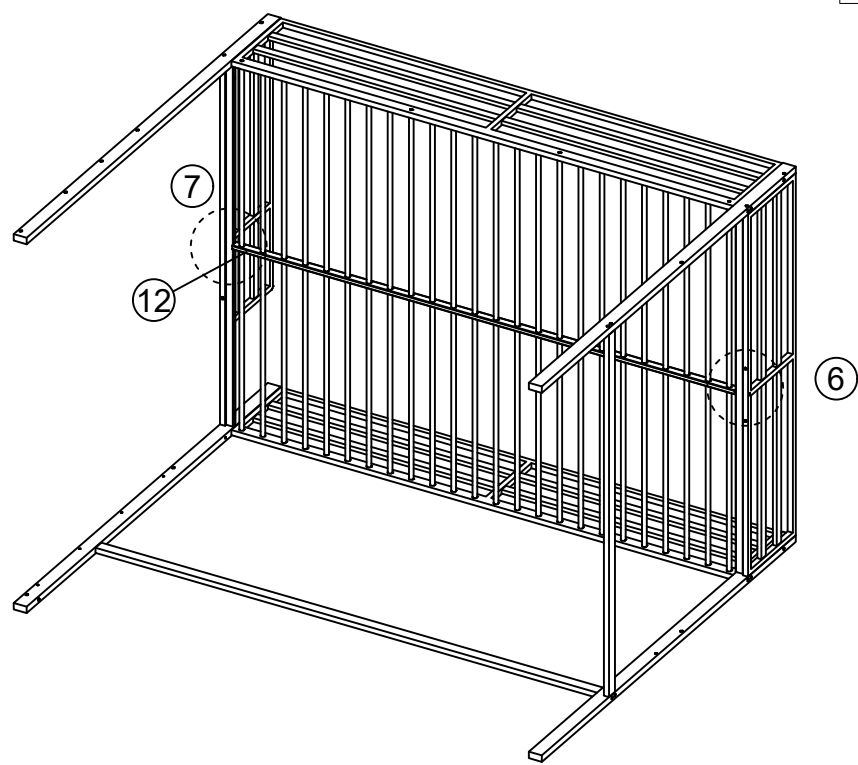

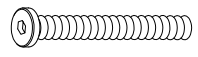
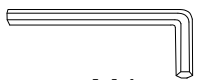
 M6*70mm	 M4
(G) × 2PCS	(U) × 1PC

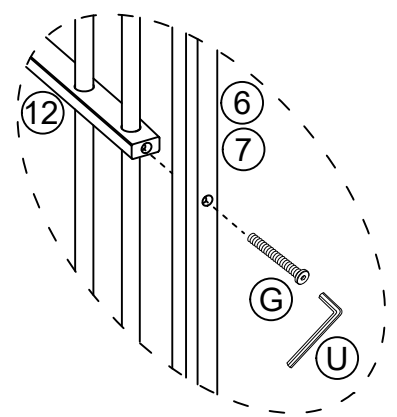

15

Turn the bed over, keeping the four bed posts perpendicular to the floor.



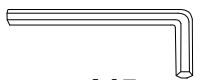

16

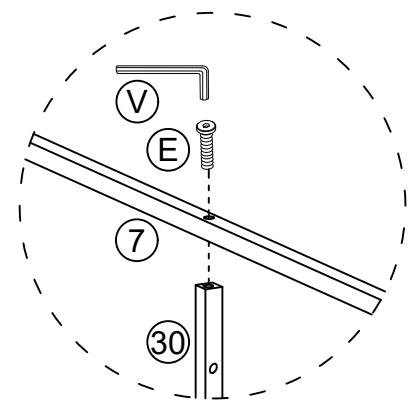
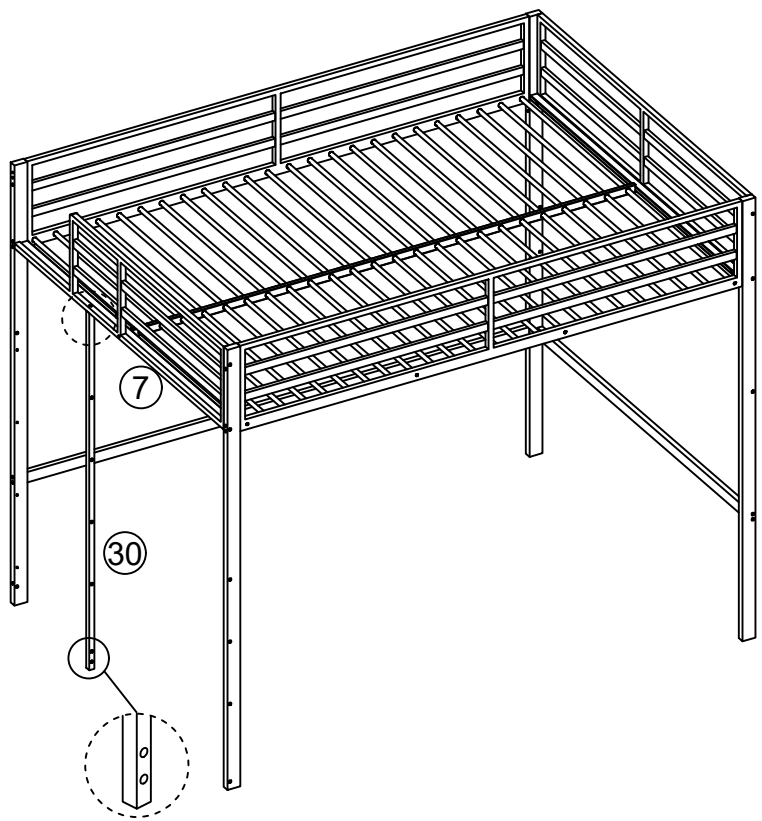
 M8×35mm	 M5
(E) × 1PC	(V) × 1PC

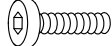
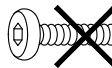



 M8*35mm
 M8*40mm

17

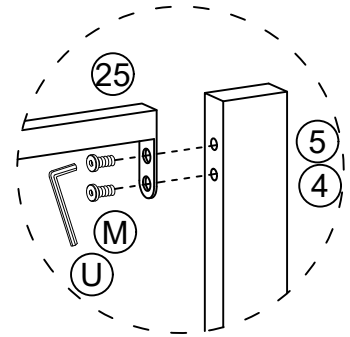
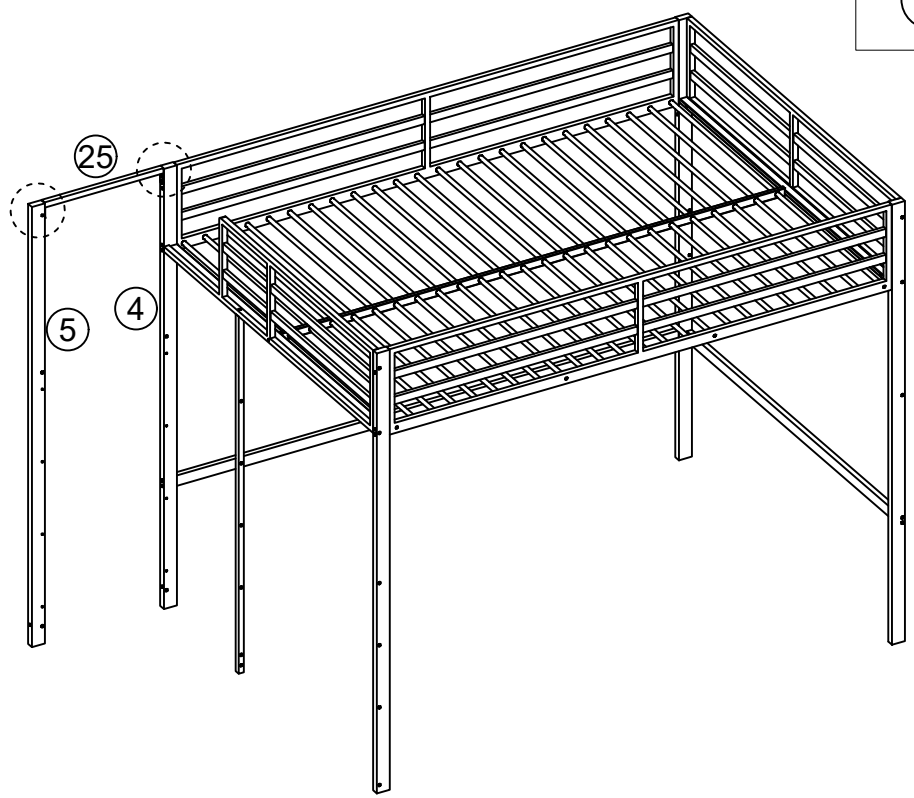
	
M6*15mm	M4
(M) × 4PCS	(U) × 1PC



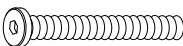
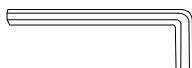

	M6*15mm
	M6*30mm

18

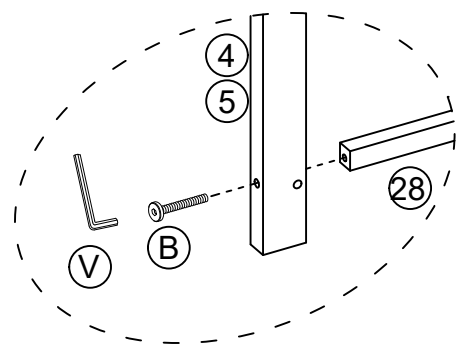
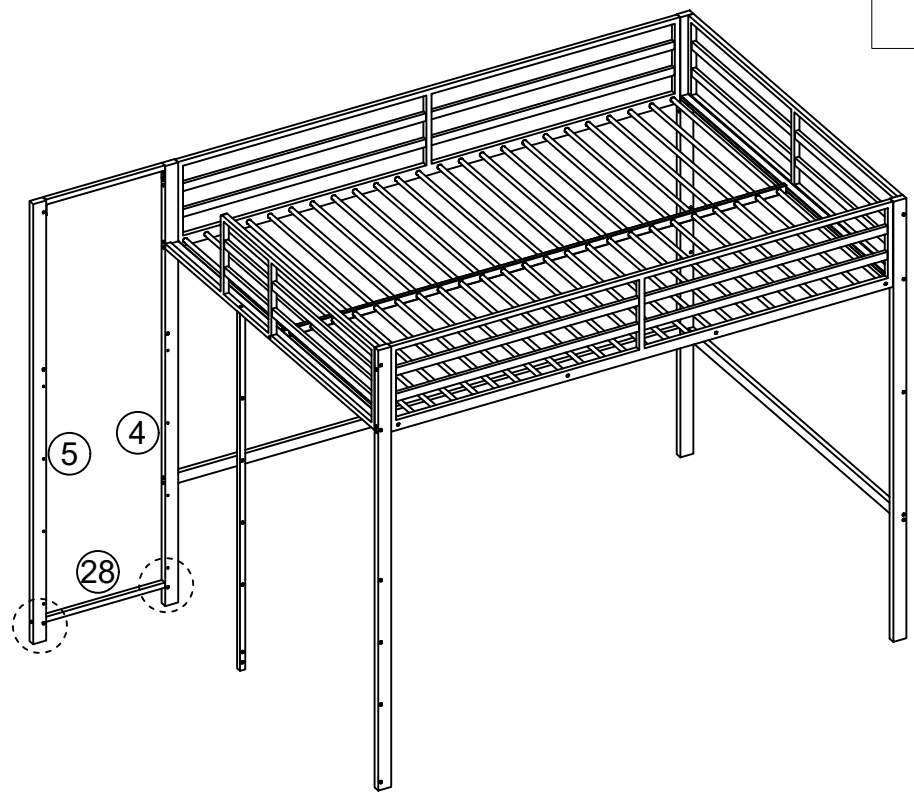

	
M8*65mm	M5
(B) × 2PCS	(V) × 1PC

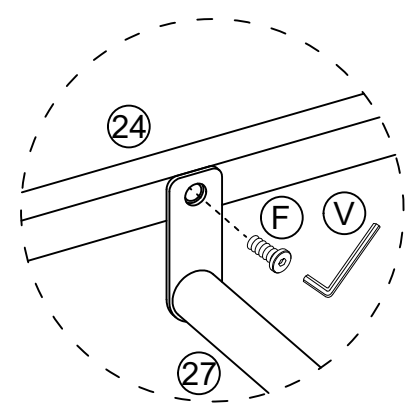
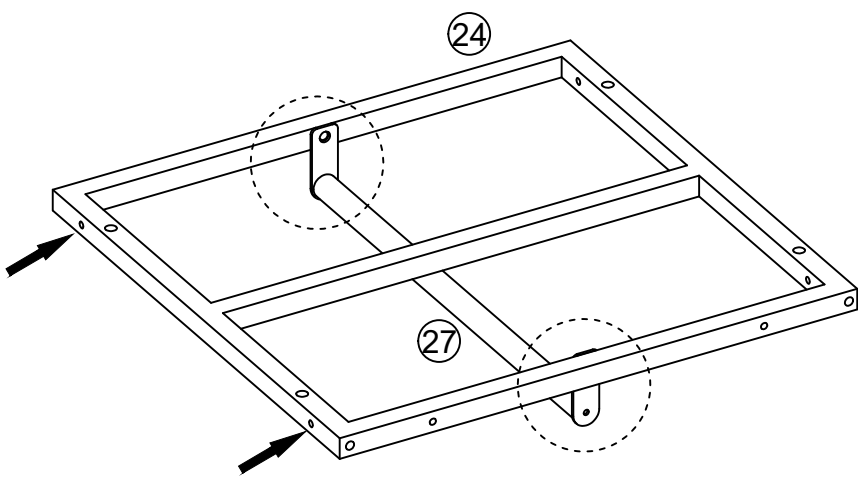

19

 M8×20mm	 M5
(F)×2PCS	(V)×1PC



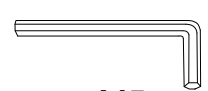

 M8*20mm
 M8*35mm

20

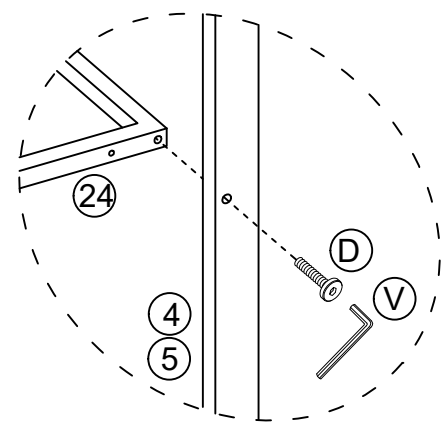
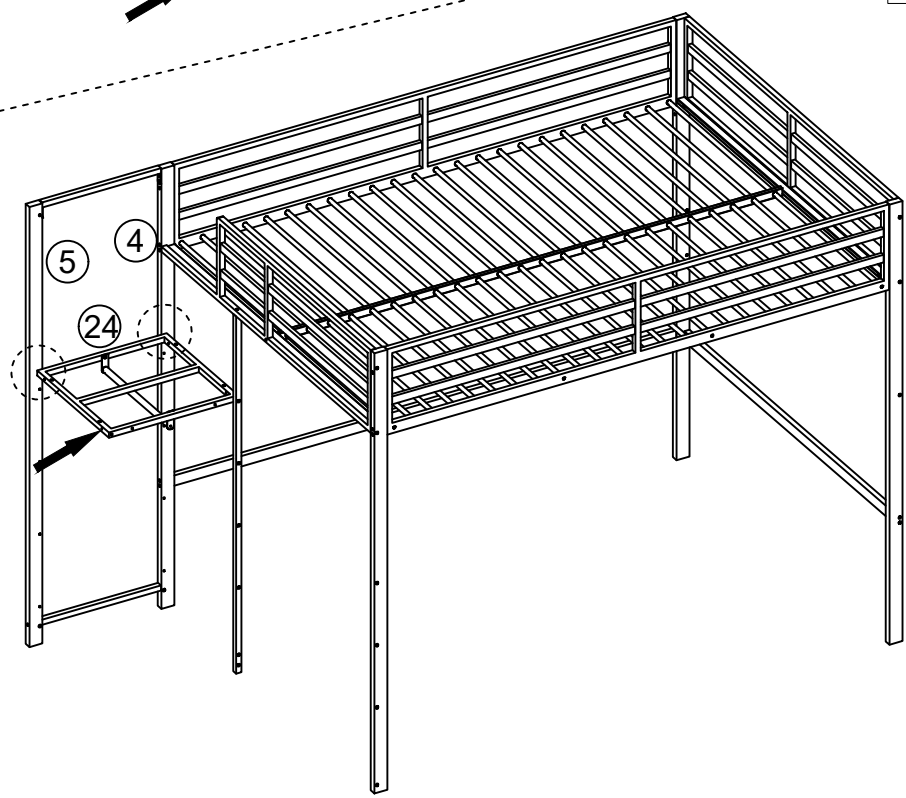
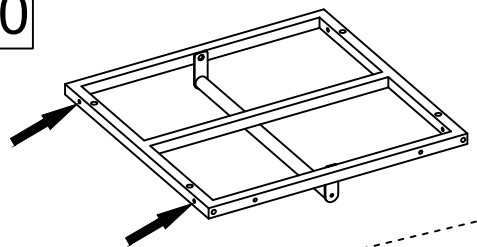
 M8×40mm	 M5
(D)×2PCS	(V)×1PC





 M8*40mm
 M8*35mm

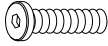
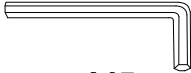

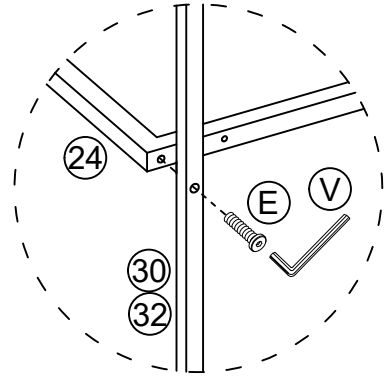
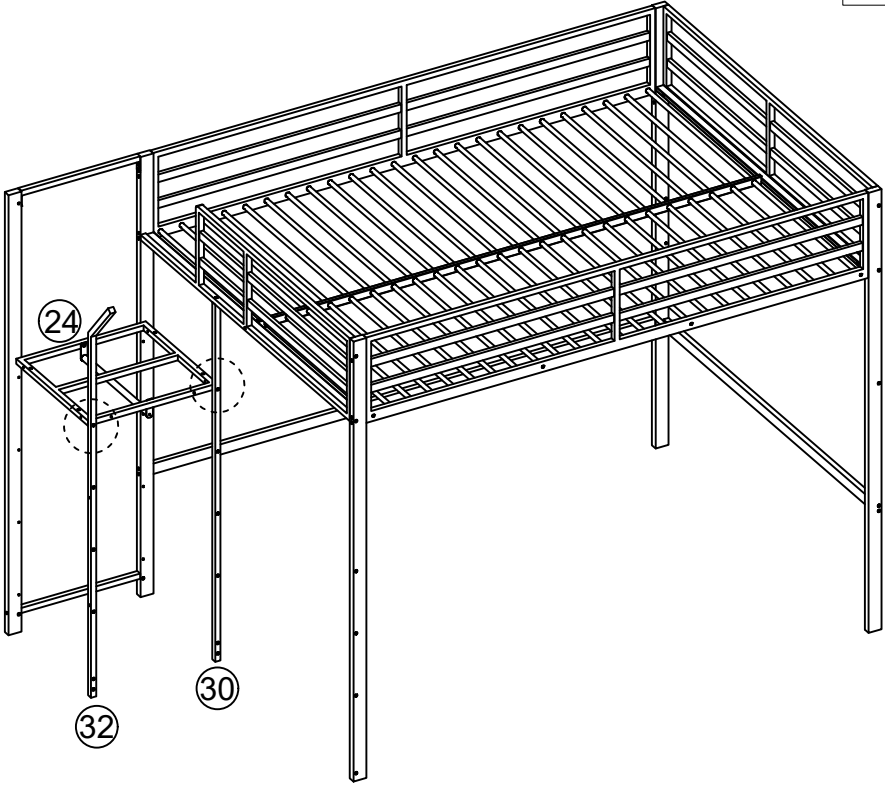
21

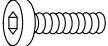
 M8×35mm	 M5
(E)×2PCS	(V)×1PC





 M8*35mm
 M8*40mm

22

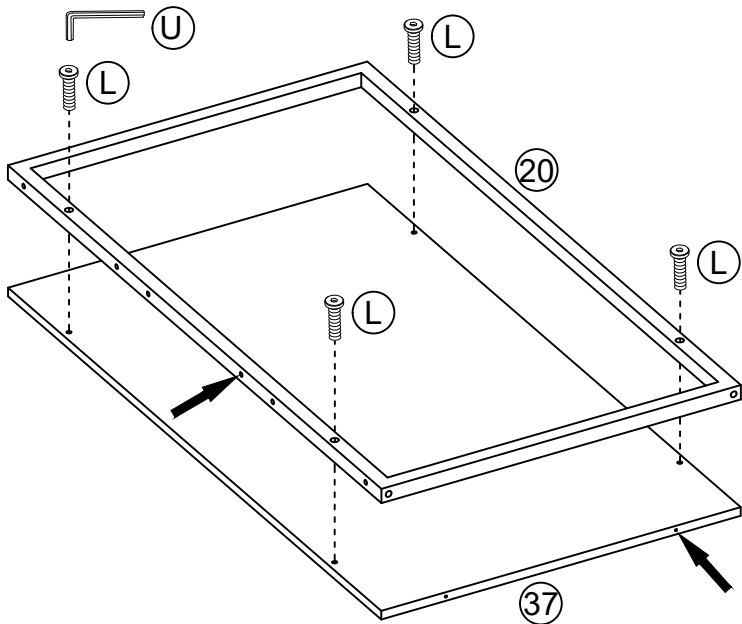
 M6×30mm	 M4
(L)×4PCS	(U)×1PC



 M6*30mm
 M6*40mm

23

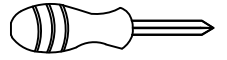

W×1PC

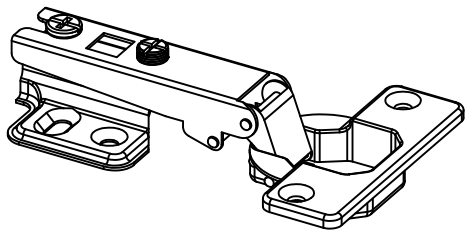
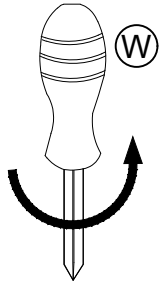

16×9

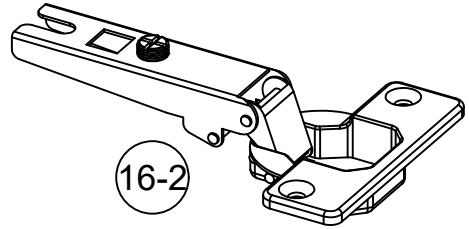

16-2

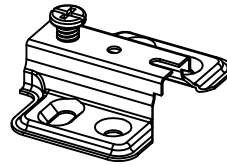

16-1

24



M3.5×14mm

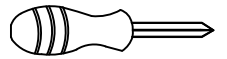

R×8PCS

W×1PC

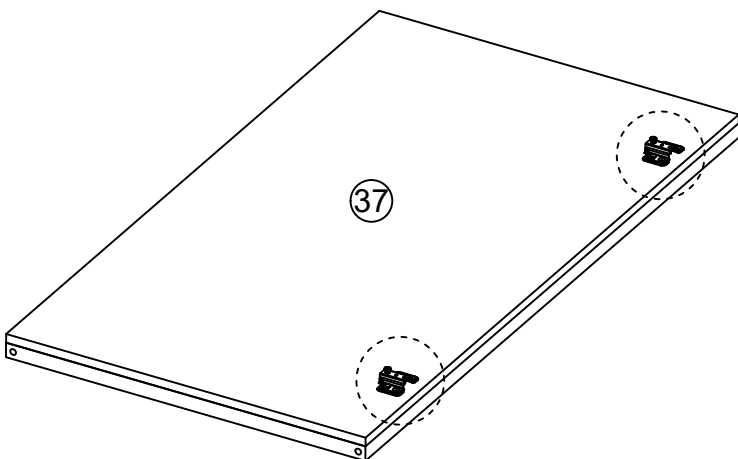

37

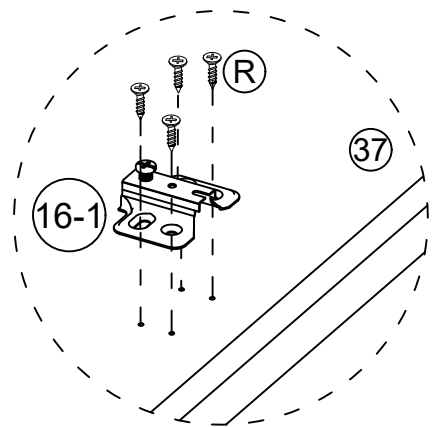



16-1

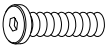

37

R

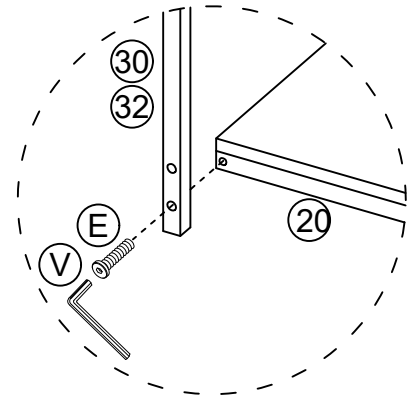
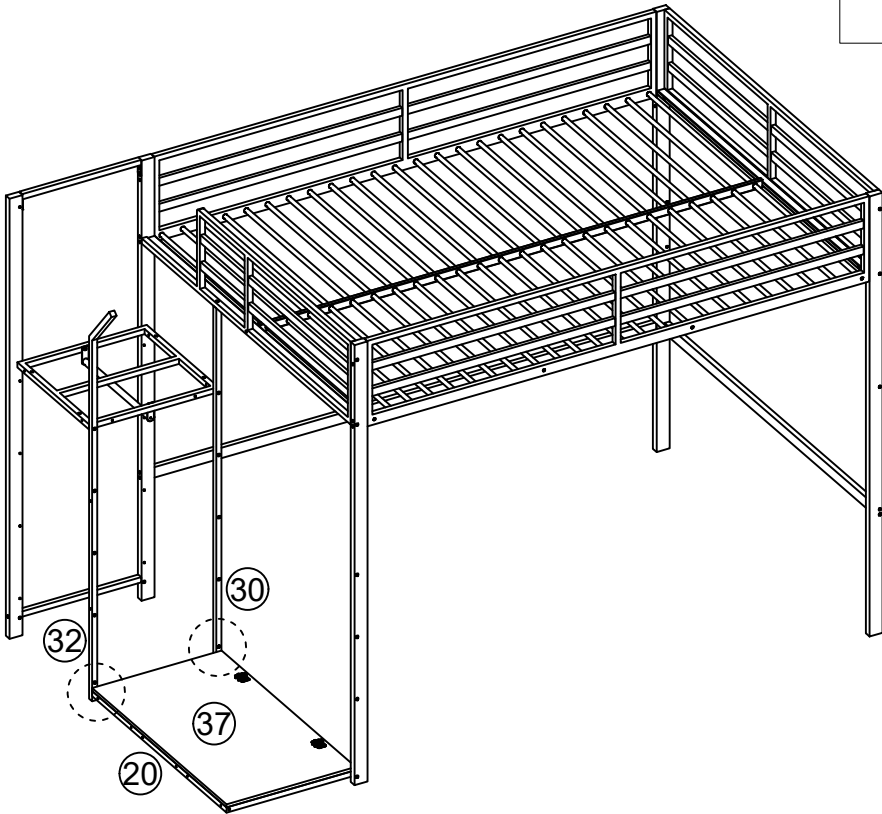

25

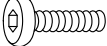
 M8×35mm	 M5
(E) × 2PCS	(V) × 1PC



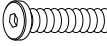

 M8*35mm
 M8*40mm

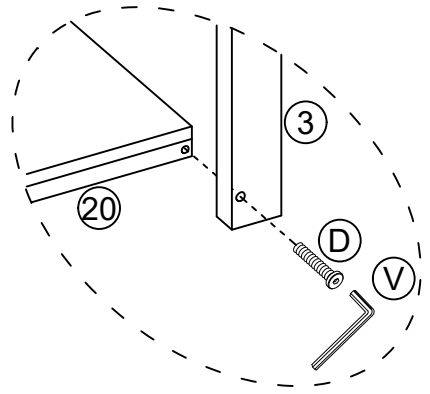
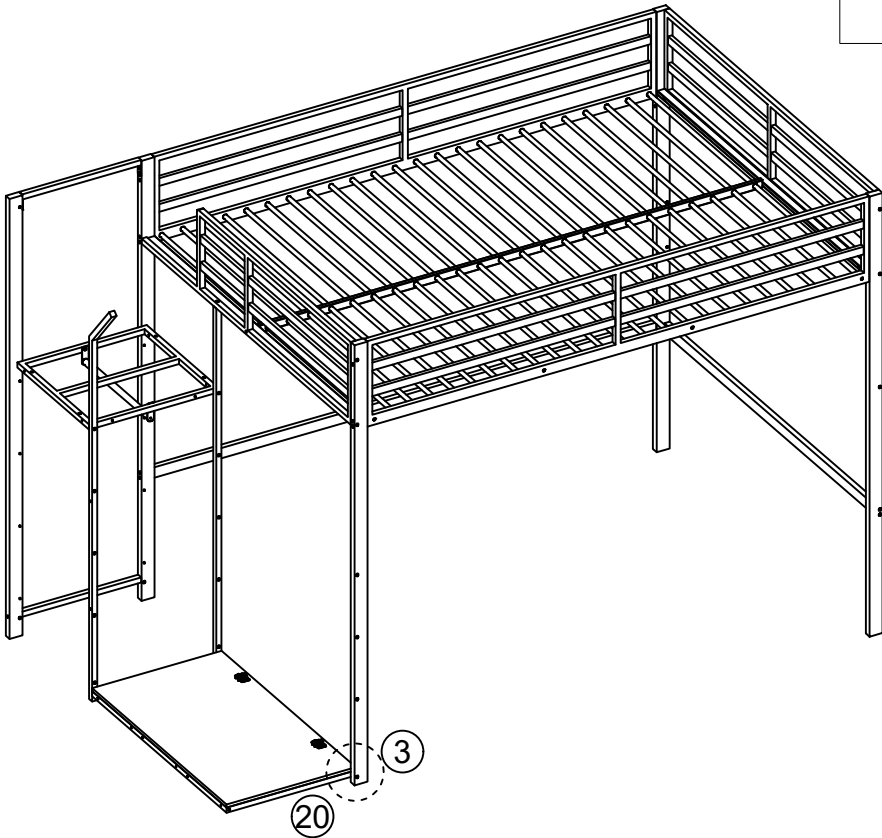

26

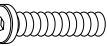
 M8×40mm	 M5
(D) × 1PC	(V) × 1PC





 M8*40mm
 M8*45mm

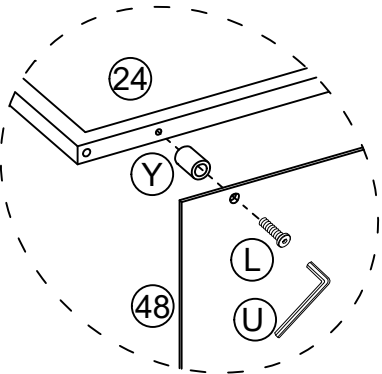
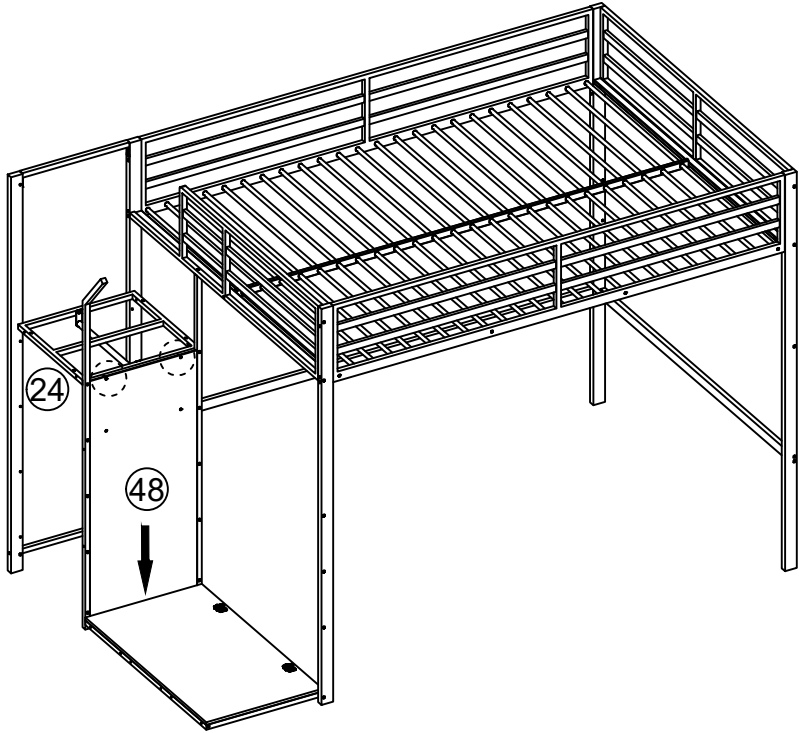

27

 M6×30mm	 M4	
(L) × 2PCS	(U) × 1PC	(Y) × 2PCS





 M6*30mm
 M6*40mm

28

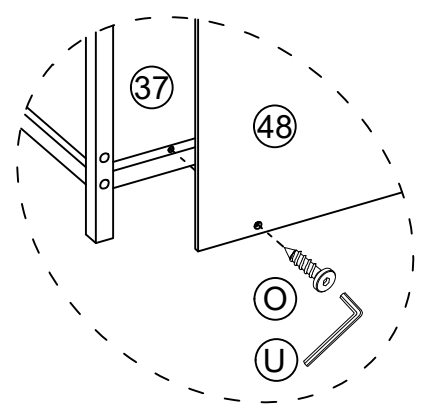
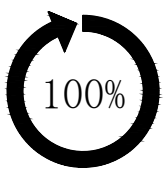
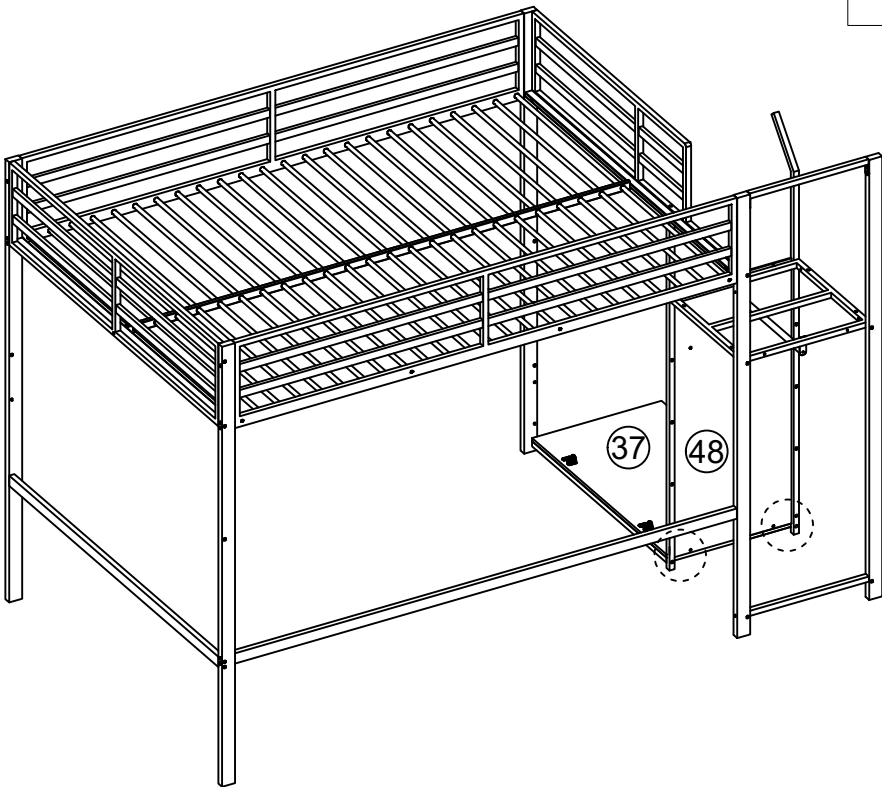

 M5×20mm	 M4
(O) × 2PCS	(U) × 1PC



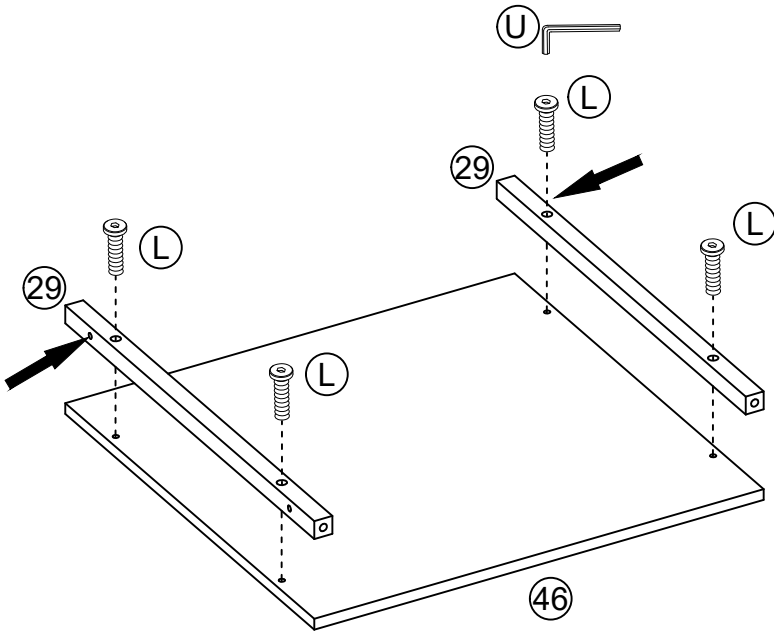

29

 M6×30mm	 M4
(L) × 4PCS	(U) × 1PC





 M6*30mm
 M6*40mm

30

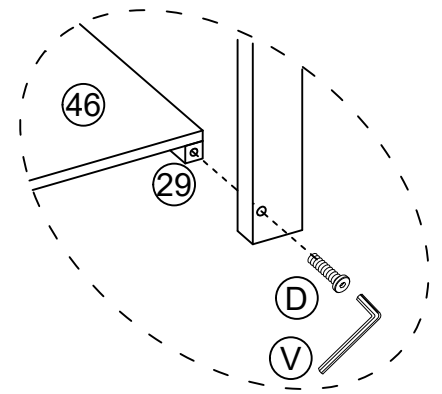
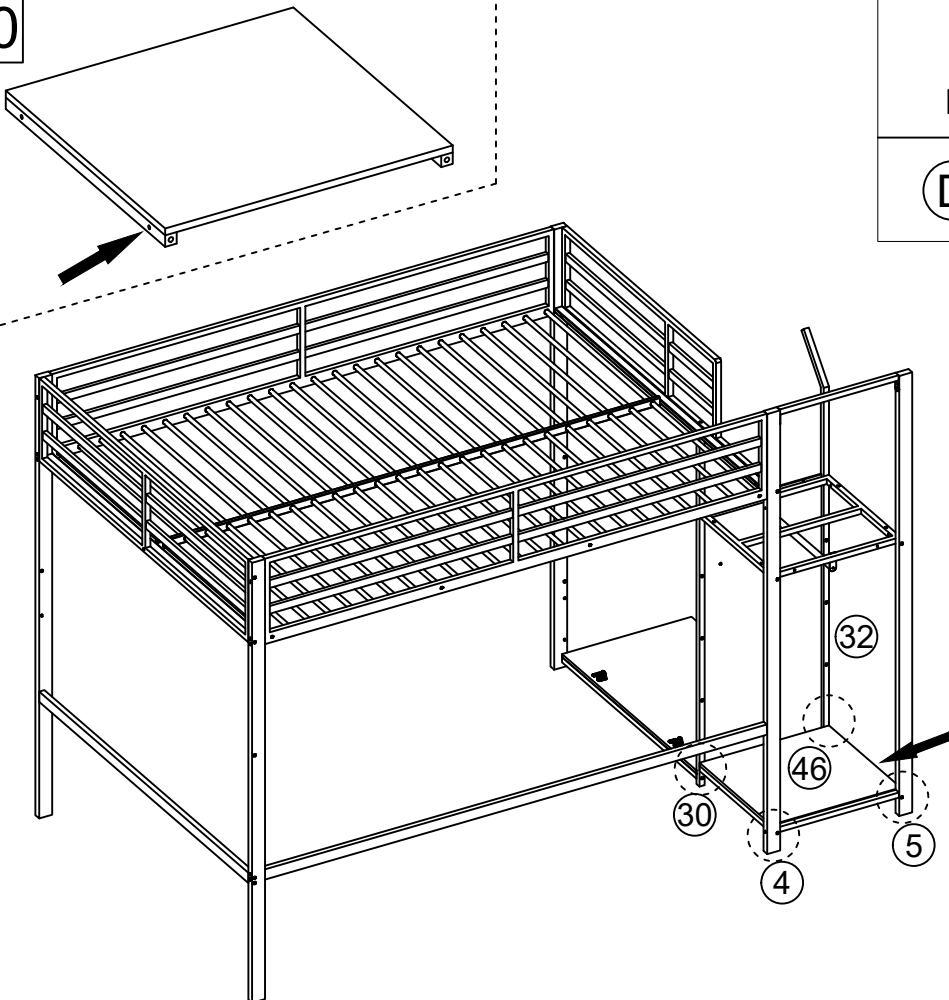

 M8×40mm	 M5
(D) × 4PCS	(V) × 1PC

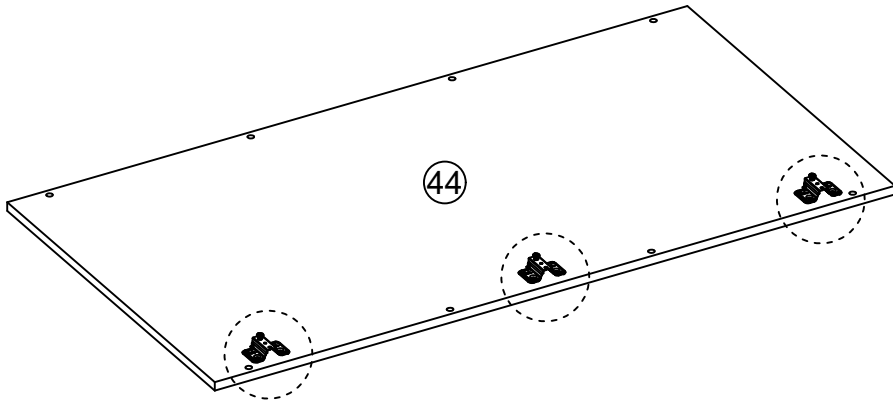

 M8*40mm
 M8*35mm

31



 M3.5×14mm	
(R)×12PCS	(W)×1PC

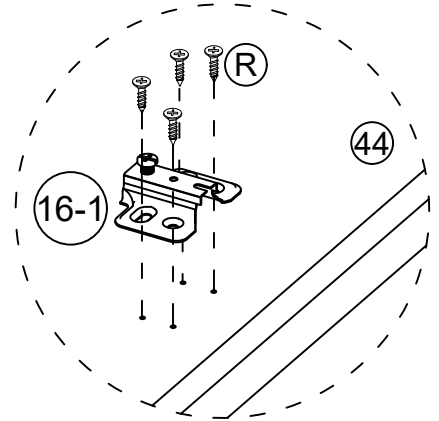

32

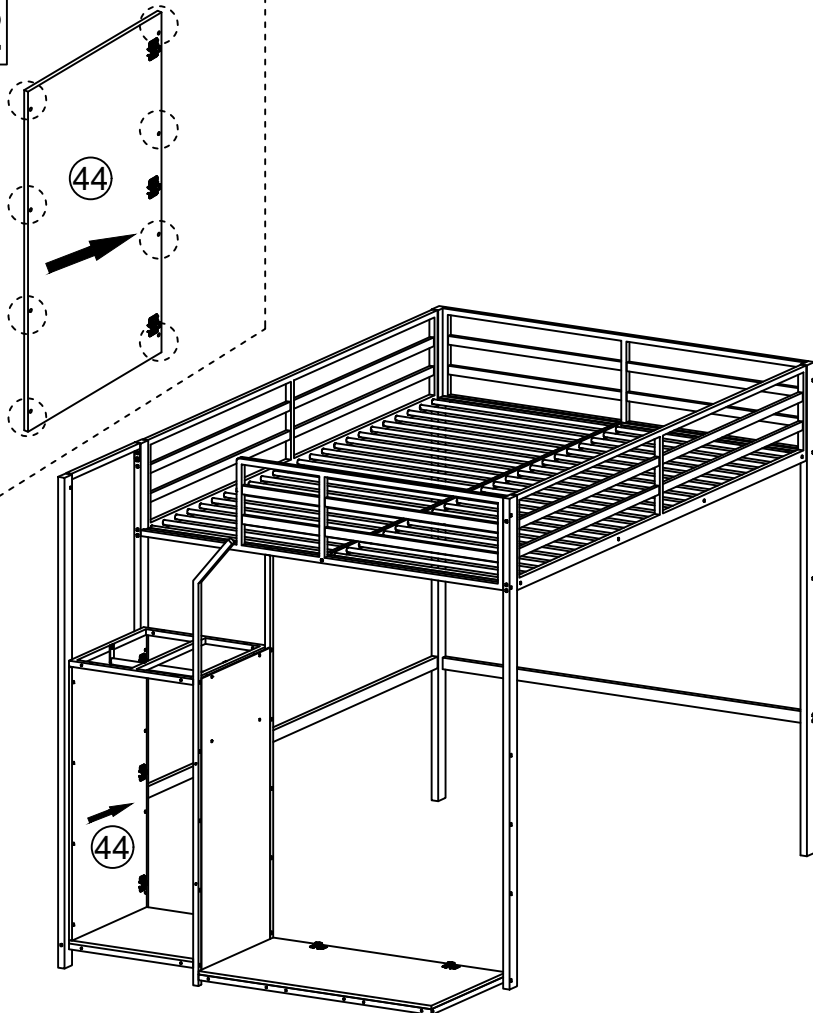

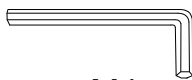

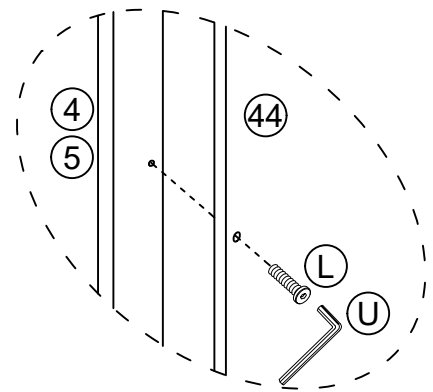
 M6×30mm	 M4
(L)×8PCS	(U)×1PC

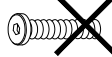

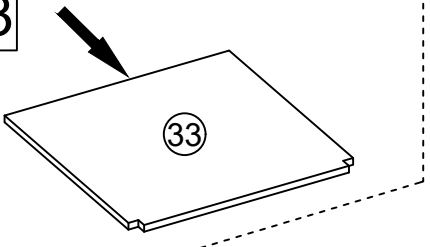

 M6*30mm
 M6*40mm

33



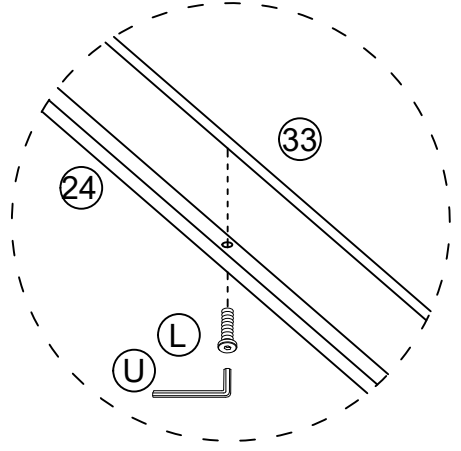
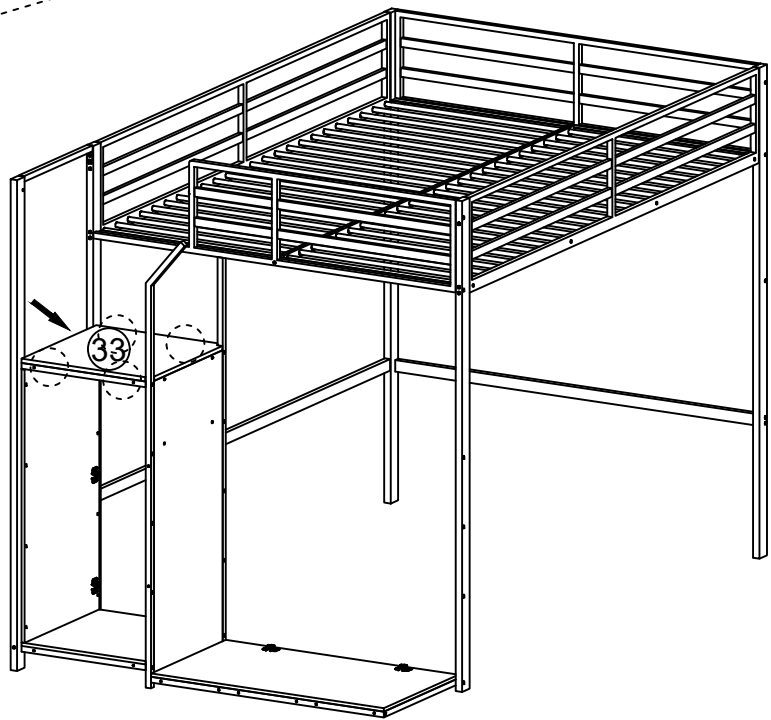

 M6×30mm	 M4
(L)×4PCS	(U)×1PC



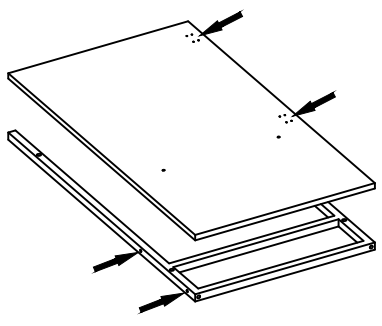

 M6*30mm
 M6*40mm

34

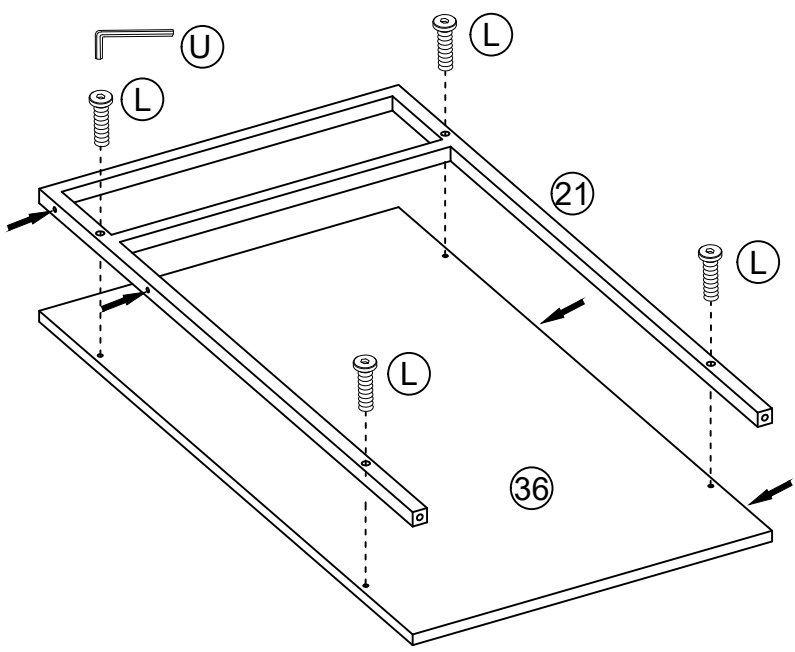

 M6×30mm	 M4
(L)×4PCS	(U)×1PC



 M6*30mm
 M6*40mm

35



M3.5×14mm

(R)×8PCS

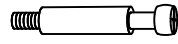

6×45mm

(S)×2PCS

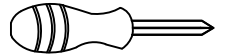

(W)×1PC

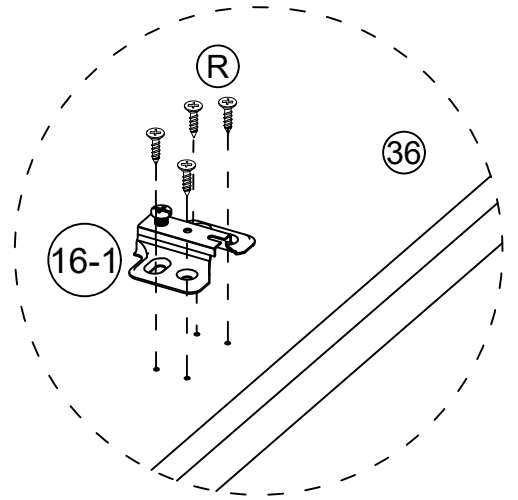
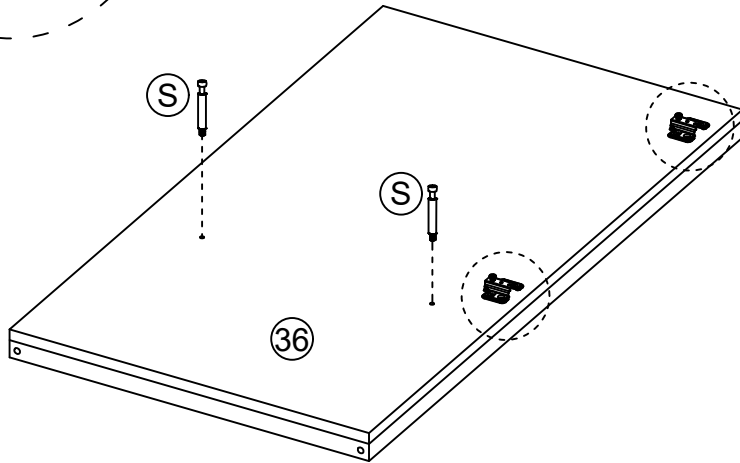
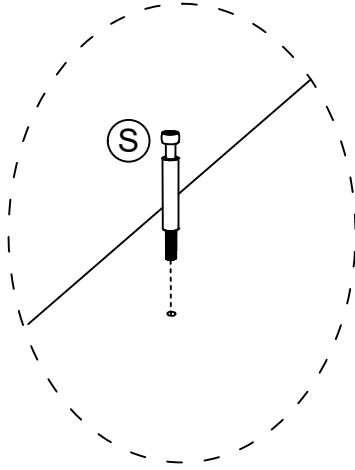

36



Ø15×12mm

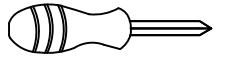

(T)×2PCS

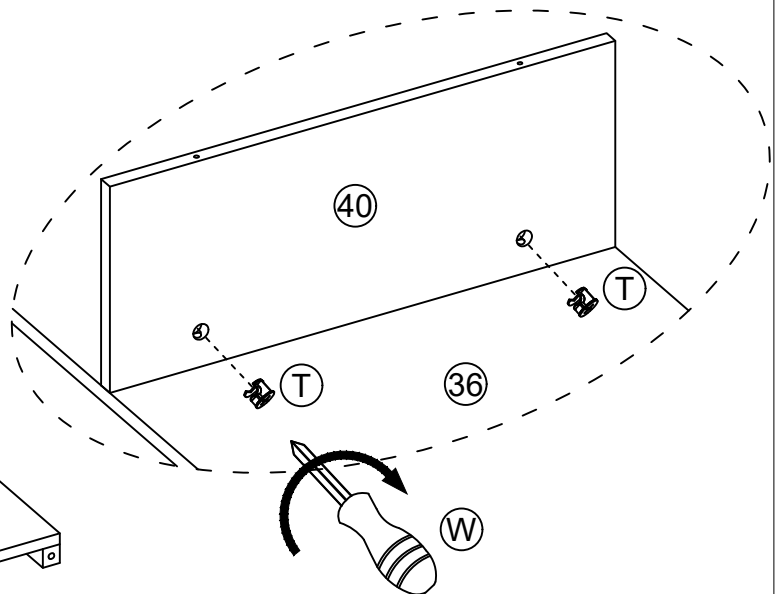
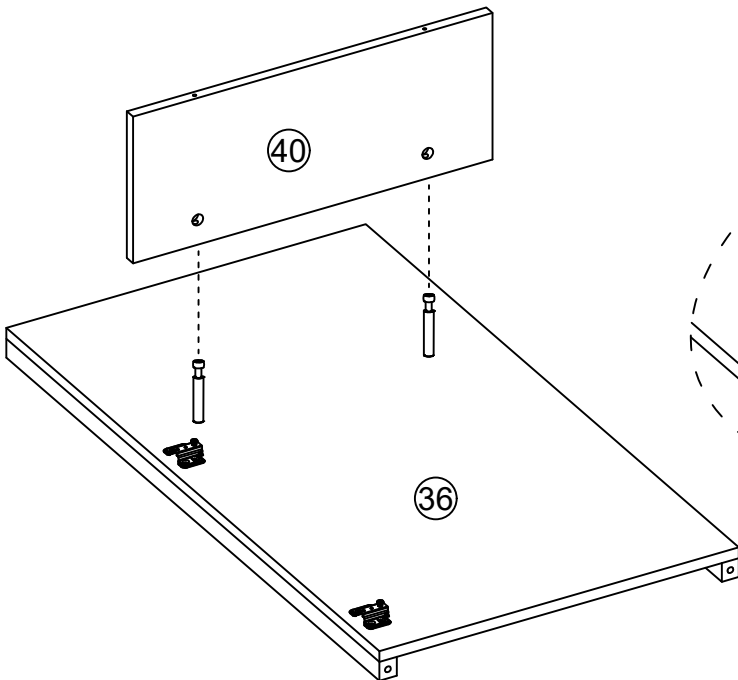

(W)×1PC



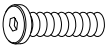

37

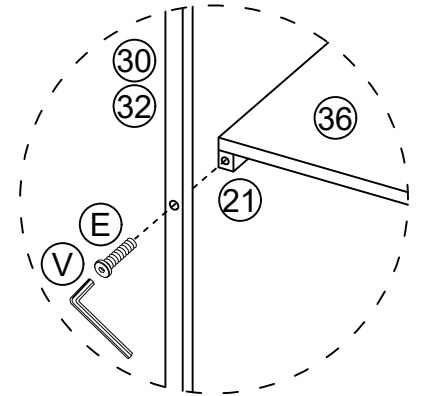
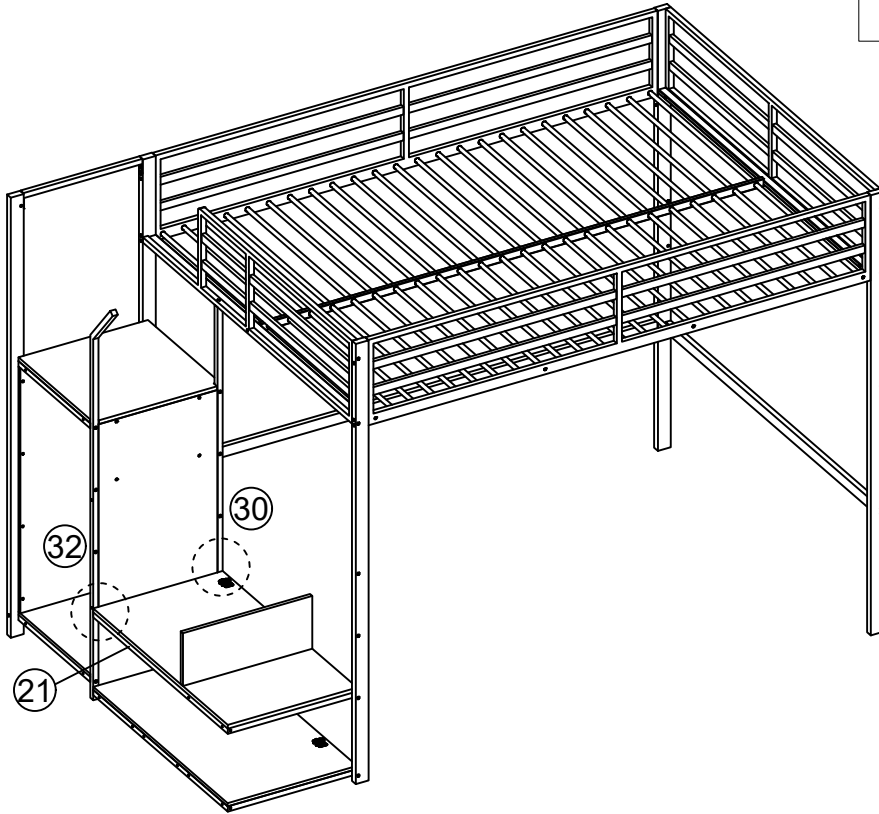
 M8×35mm	 M5
(E) × 2PCS	(V) × 1PC

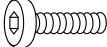
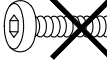

 M8*35mm
 M8*40mm

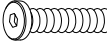

38

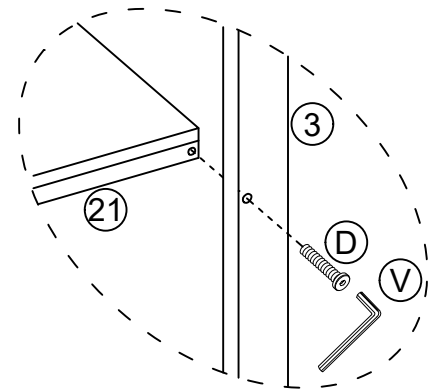
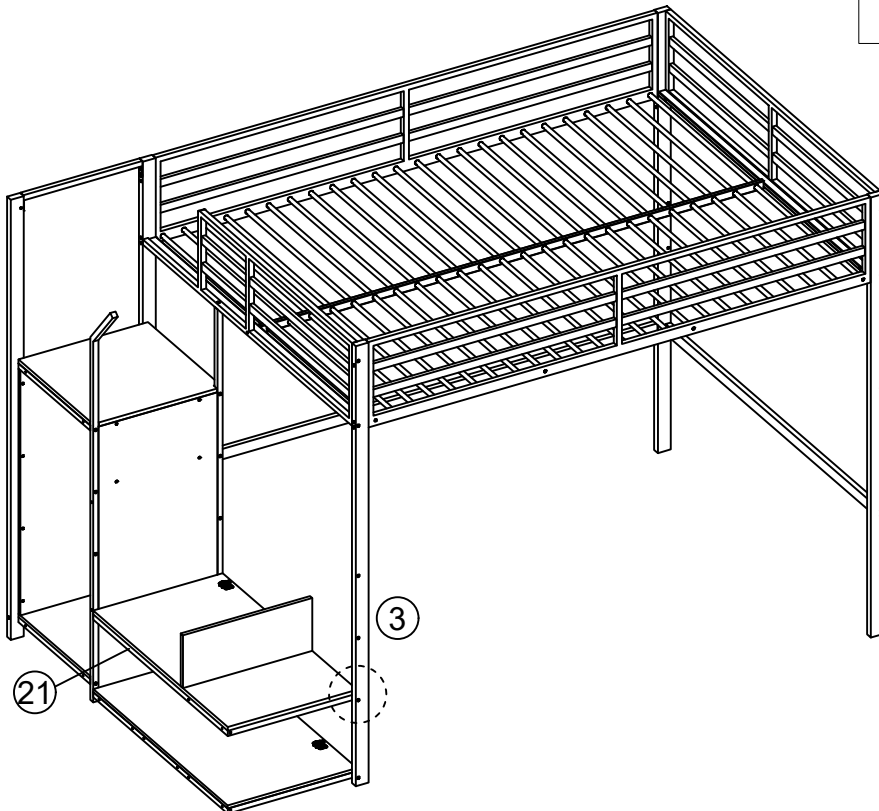
 M8×40mm	 M5
(D) × 1PC	(V) × 1PC

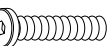
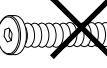

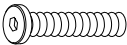

 M8*40mm
 M8*45mm

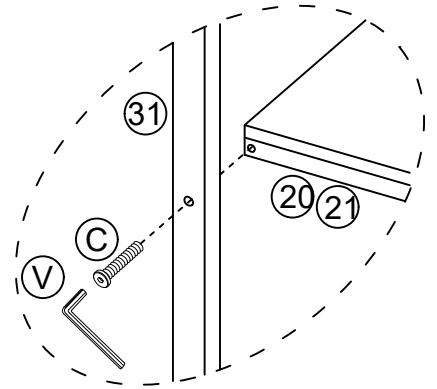
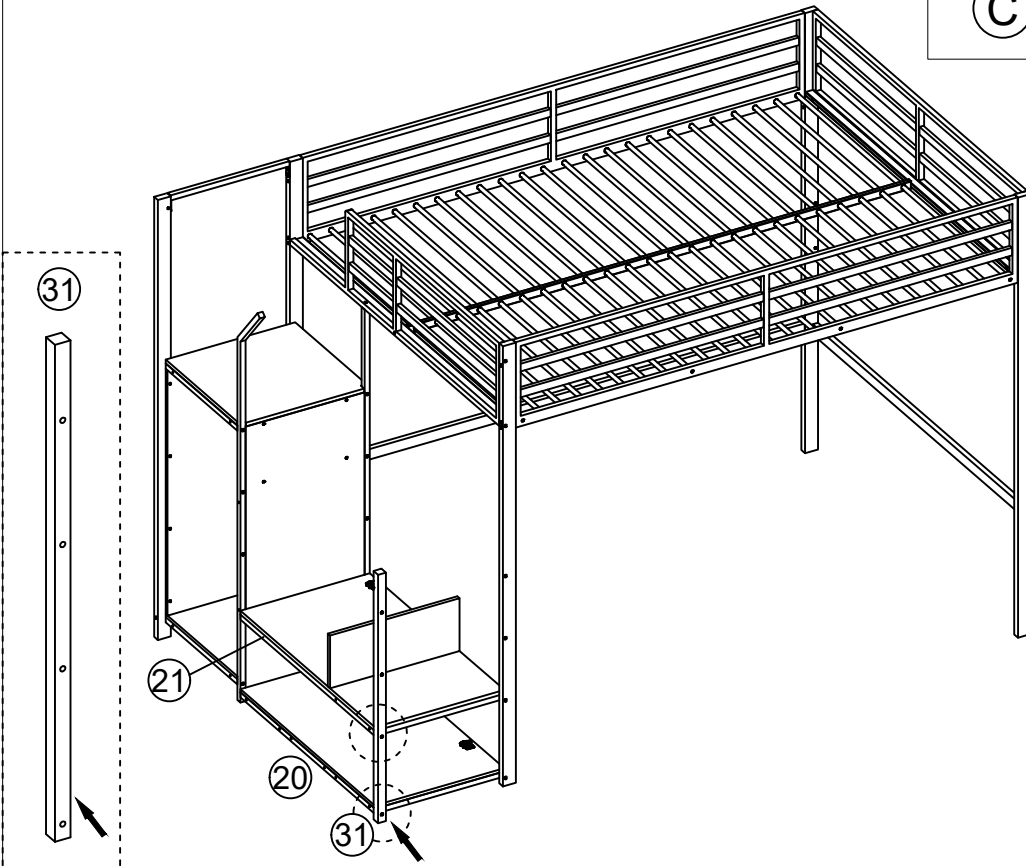

39

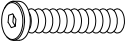
	
M8×45mm	M5
(C) × 2PCS	(V) × 1PC



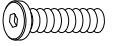

	M8*45mm
	M8*40mm

40

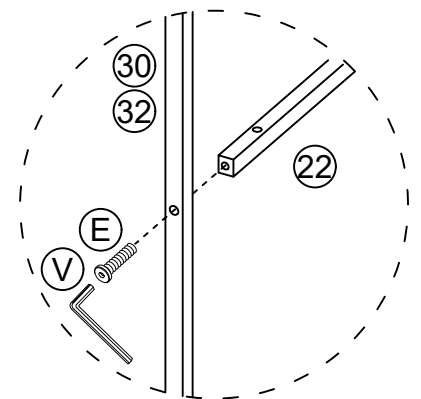
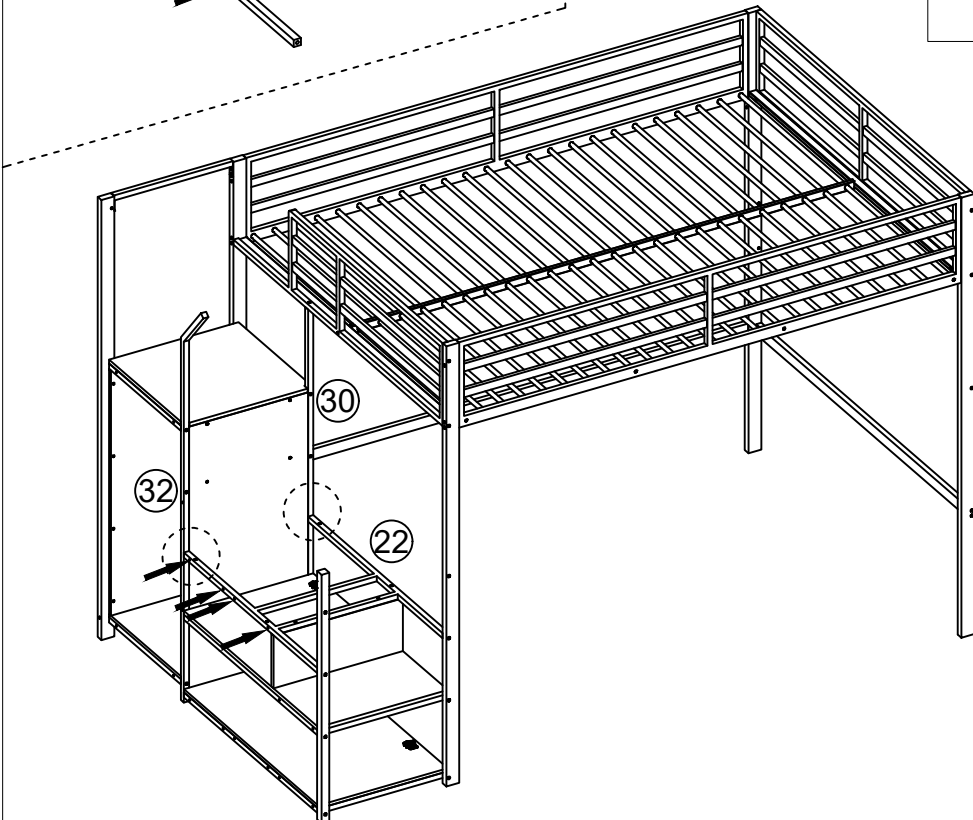
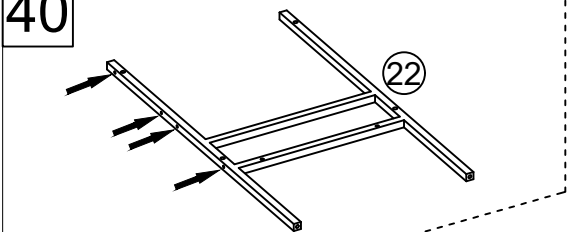

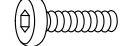
	
M8×35mm	M5
(E) × 2PCS	(V) × 1PC

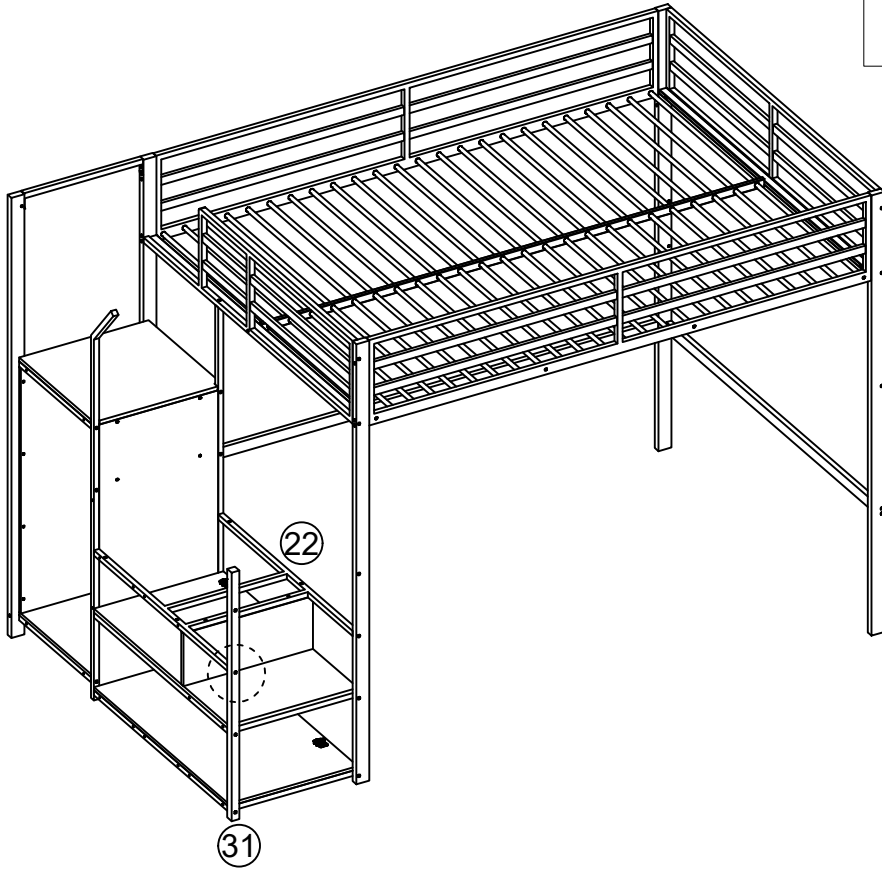

	M8*35mm
	M8*40mm

41

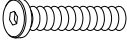

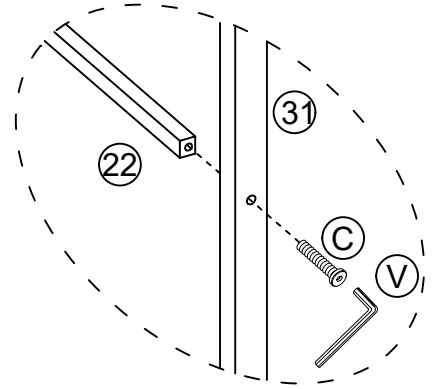

 M8×45mm	 M5
(C)×1PC	(V)×1PC

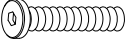
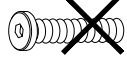

 M8*45mm
 M8*40mm

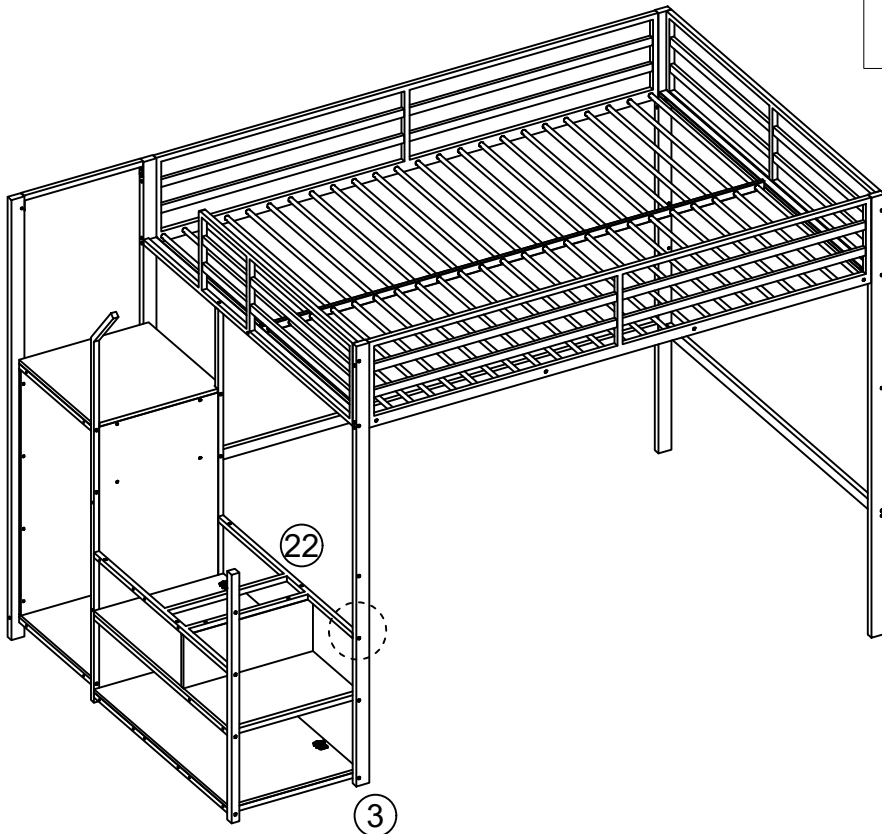
42

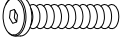

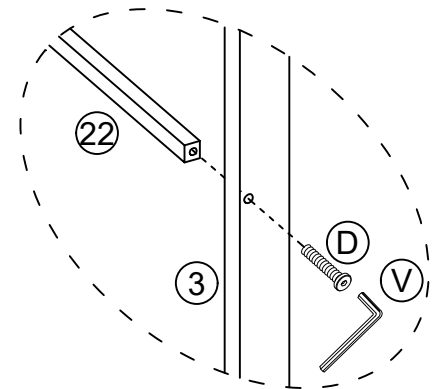

 M8×40mm	 M5
(D)×1PC	(V)×1PC

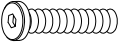
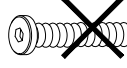

 M8*40mm
 M8*45mm

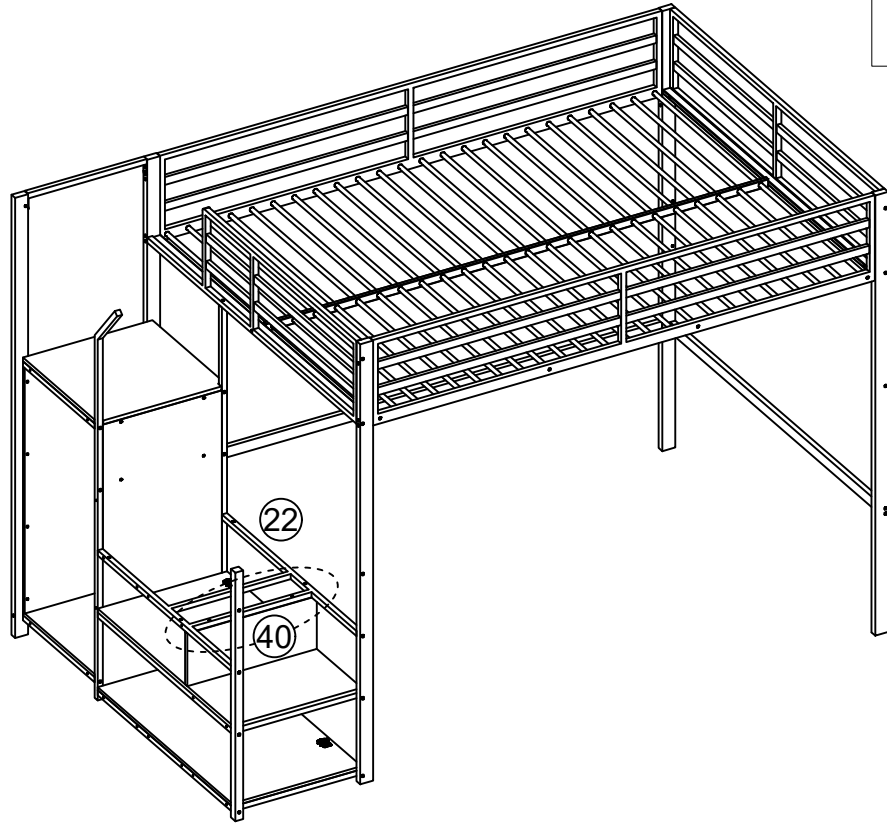

43

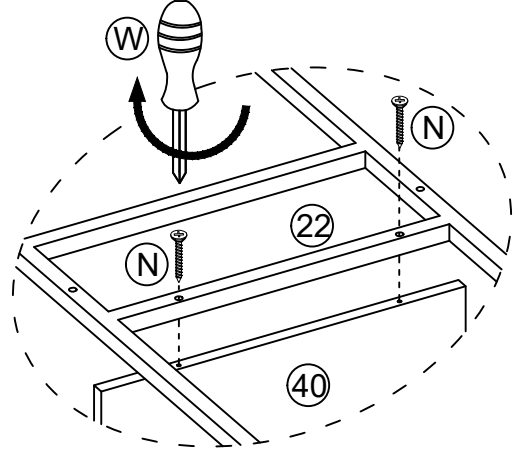

 M5×40mm	
(N)×2PCS	(W)×1PC



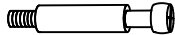

44

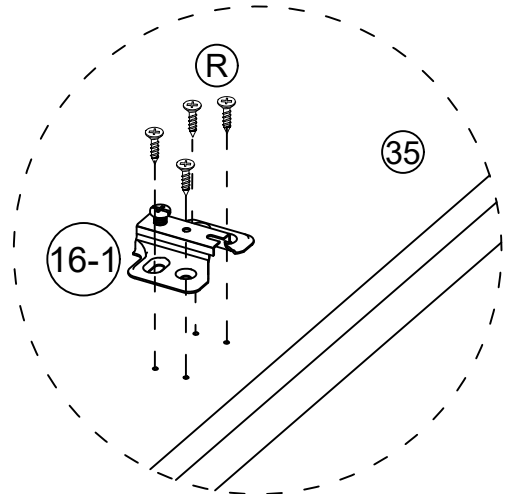
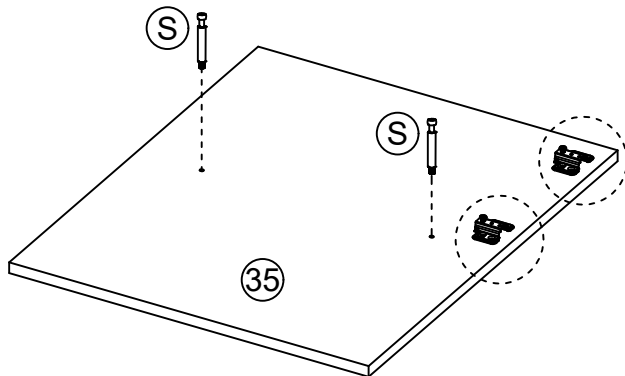
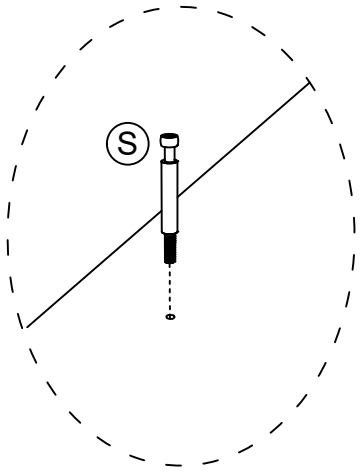
 6×45mm	 M3.5×14mm	
(S)×2PCS	(R)×8PCS	(W)×1PC

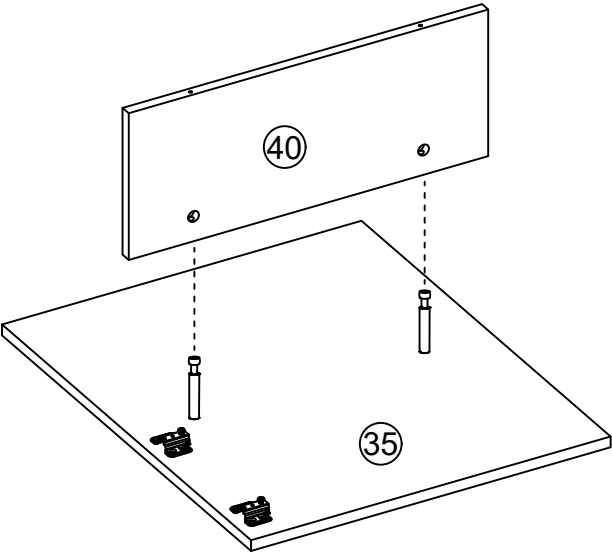

45



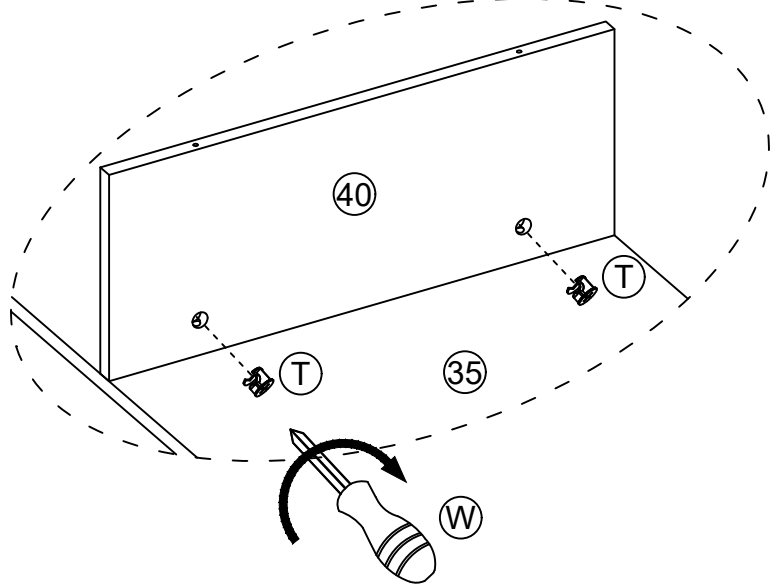

 Ø15×12mm	
(T) × 2PCS	(W) × 1PC



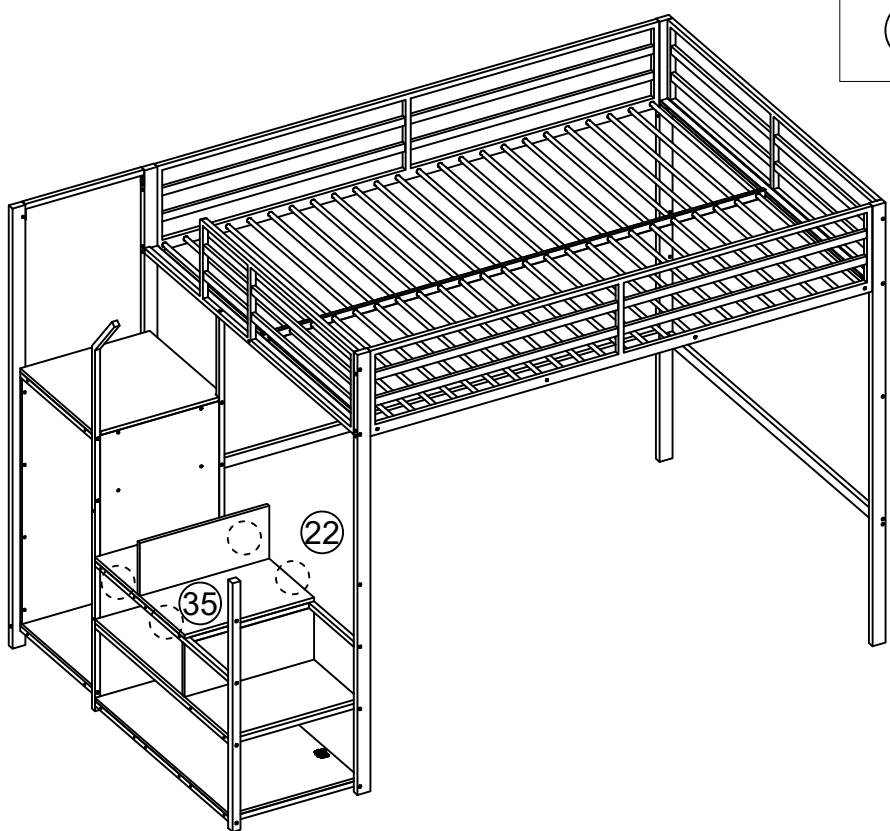

46

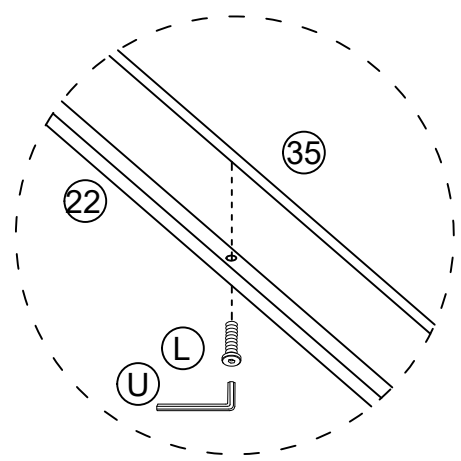

 M6×30mm	 M4
(L) × 4PCS	(U) × 1PC



 M6*30mm
 M6*40mm

47

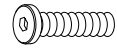
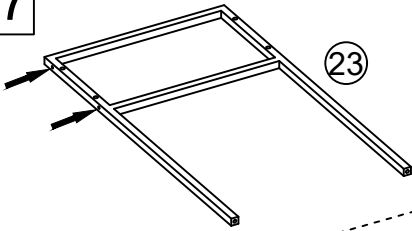

M8×35mm



M5

(E) × 2PCS

(V) × 1PC

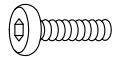
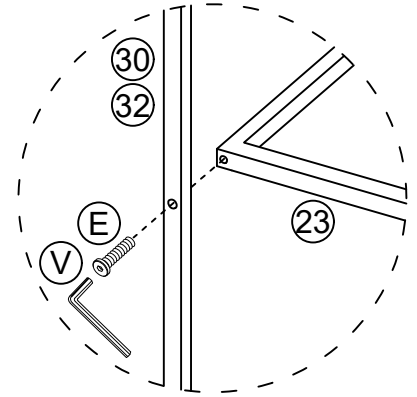
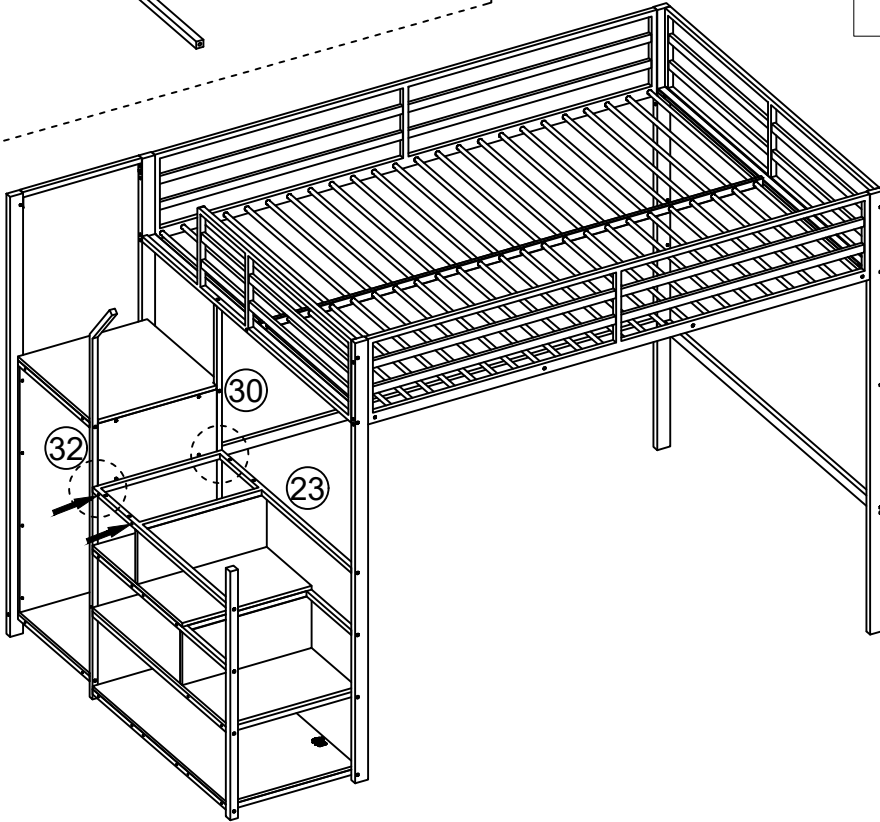

M8*35mm

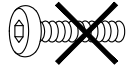

M8*40mm

48

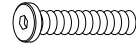

M8×45mm



M5

(C) × 1PC

(V) × 1PC

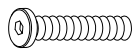
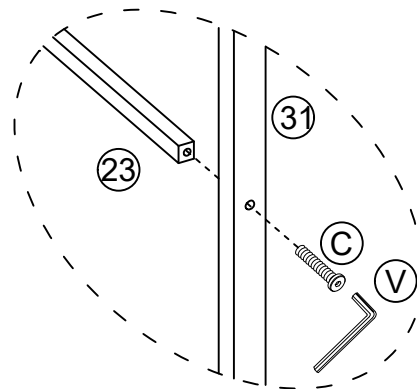
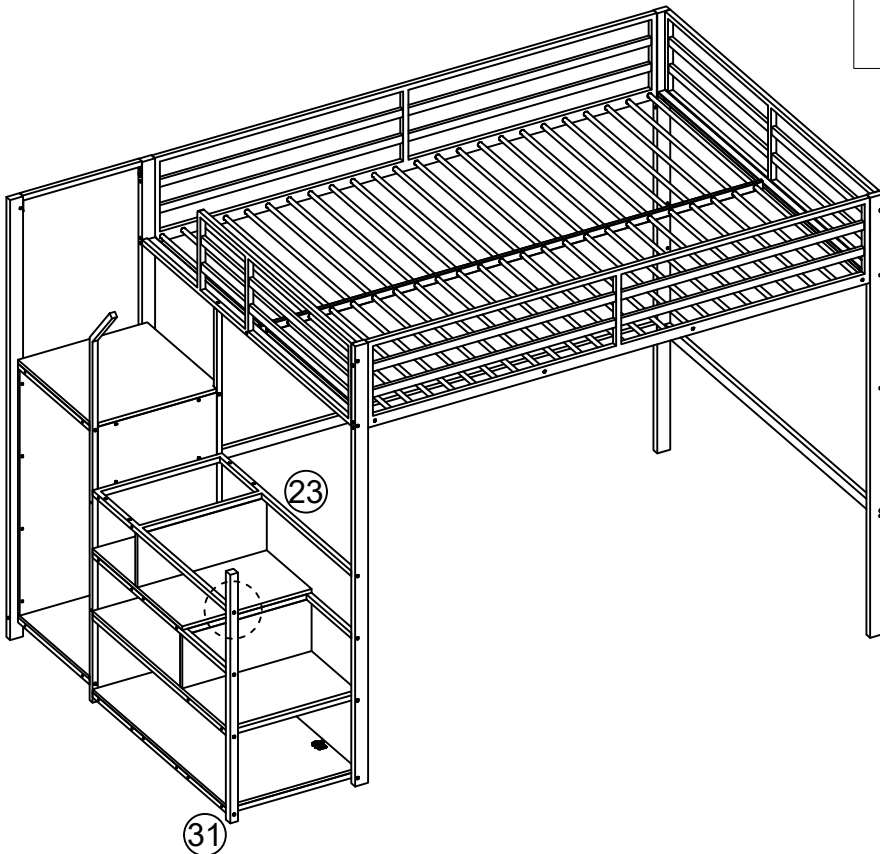

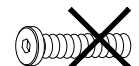

M8*45mm



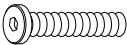

M8*40mm

49

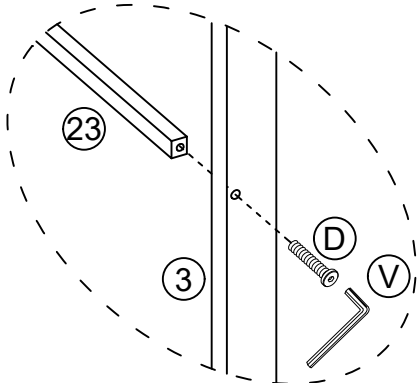
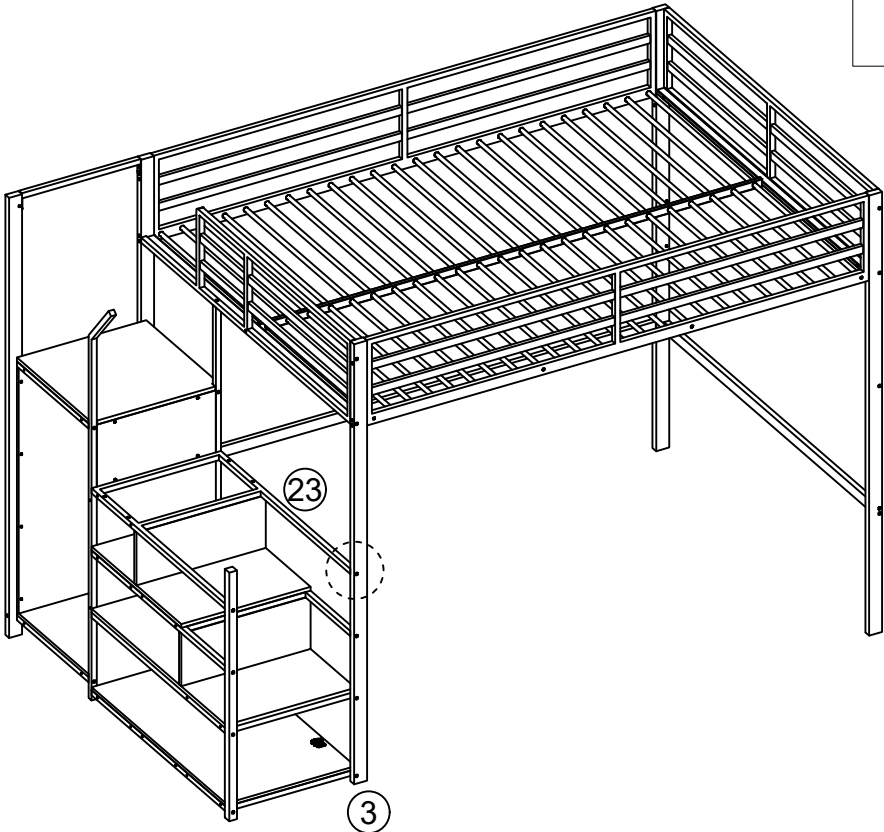
 M8×40mm	 M5
(D)×1PC	(V)×1PC

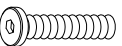

 M8*40mm
 M8*45mm

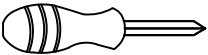

50

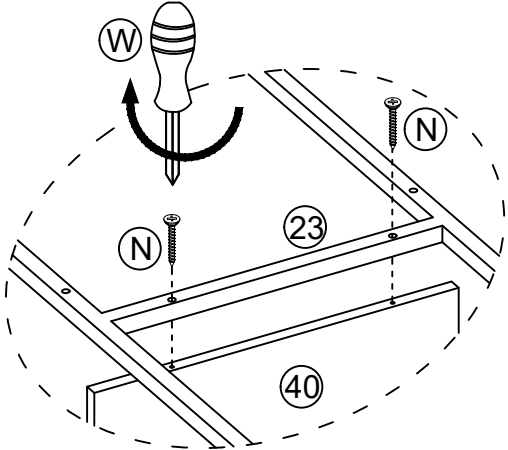
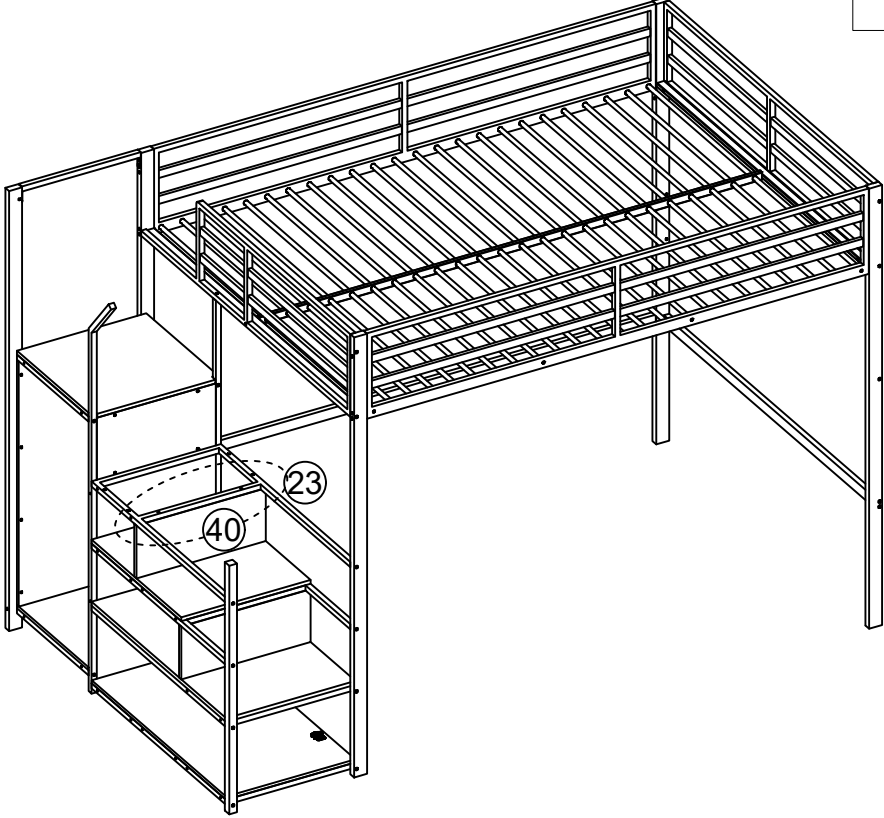
 M5×40mm	
(N)×2PCS	(W)×1PC

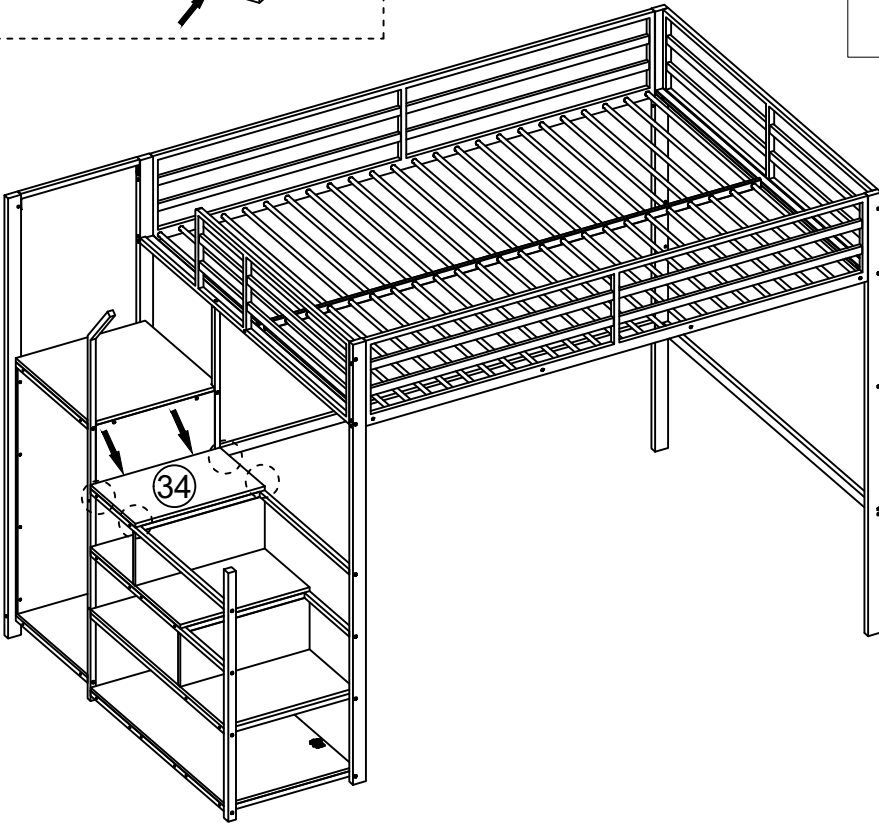
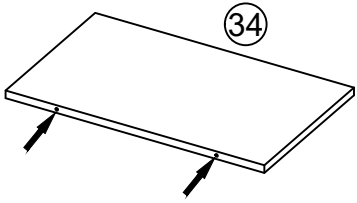

51



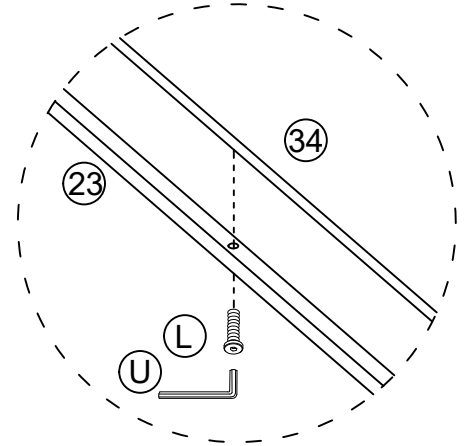

 M6×30mm	 M4
(L) × 4PCS	(U) × 1PC

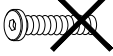

 M6*30mm
 M6*40mm

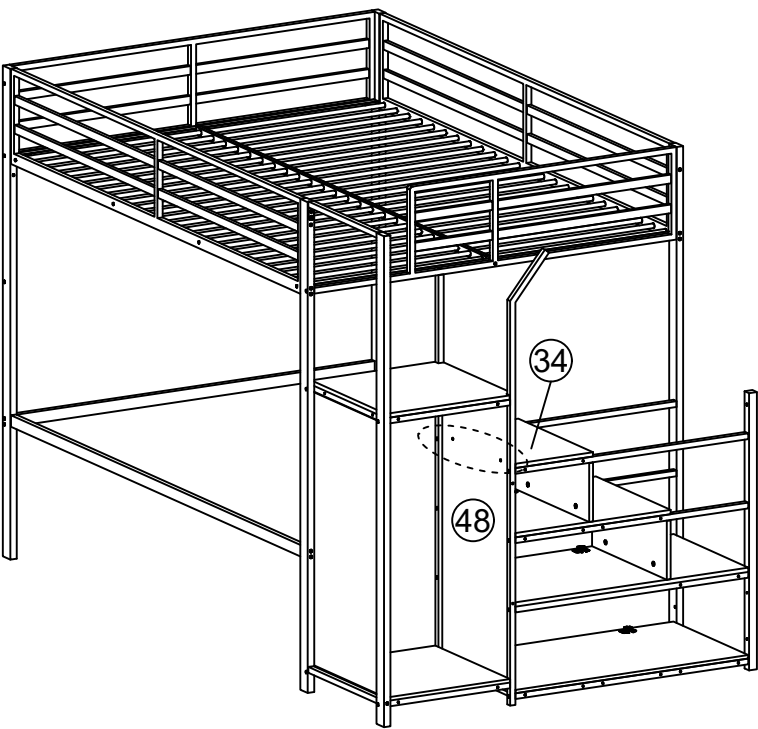
52



 M5×20mm	 M4
(O) × 2PCS	(U) × 1PC

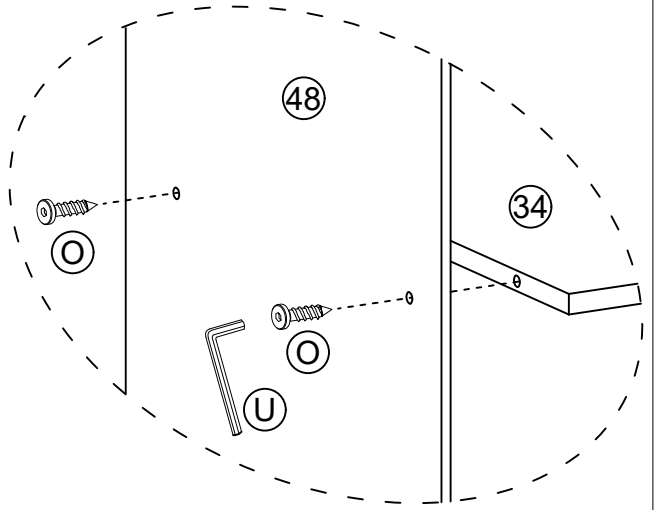

53

Pay attention to the direction, there are two small holes here

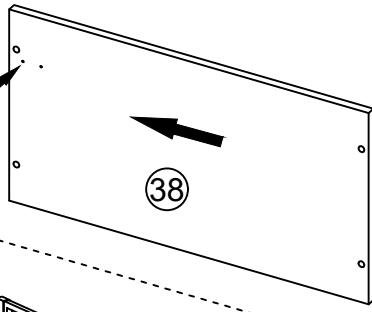

M6×30mm

(L) × 4PCS



M4

(U) × 1PC

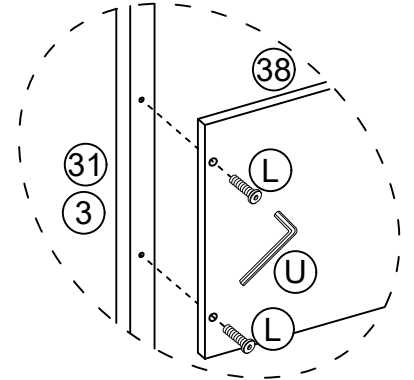
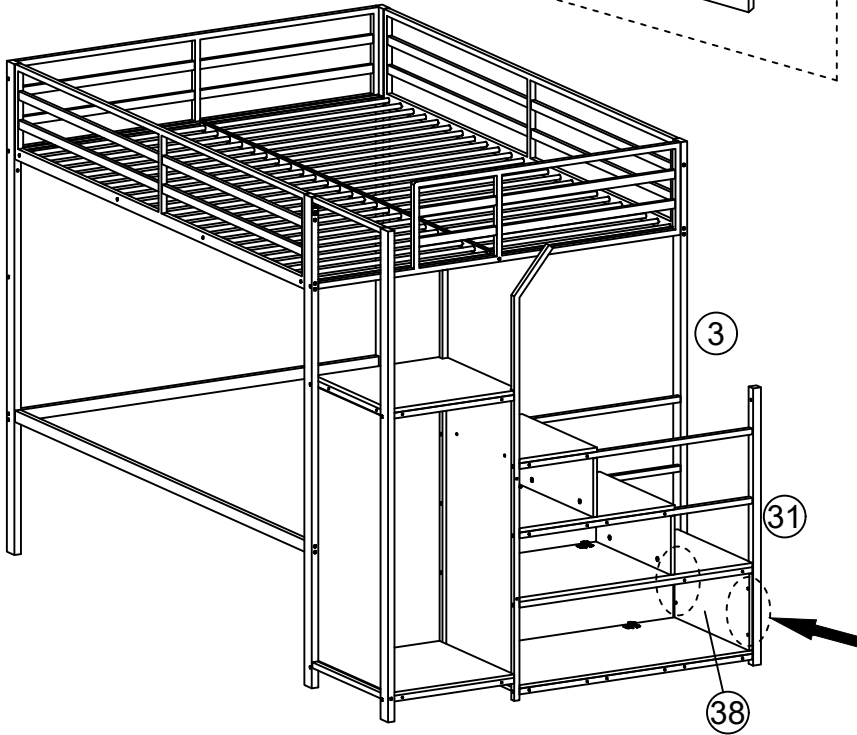

M6*30mm



M6*40mm

54

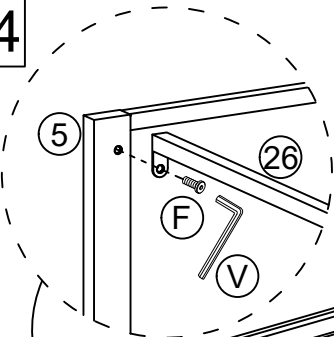

M8×20mm

(F) × 2PCS



M5

(V) × 1PC

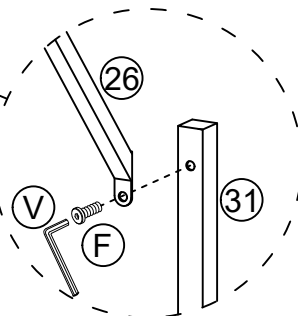
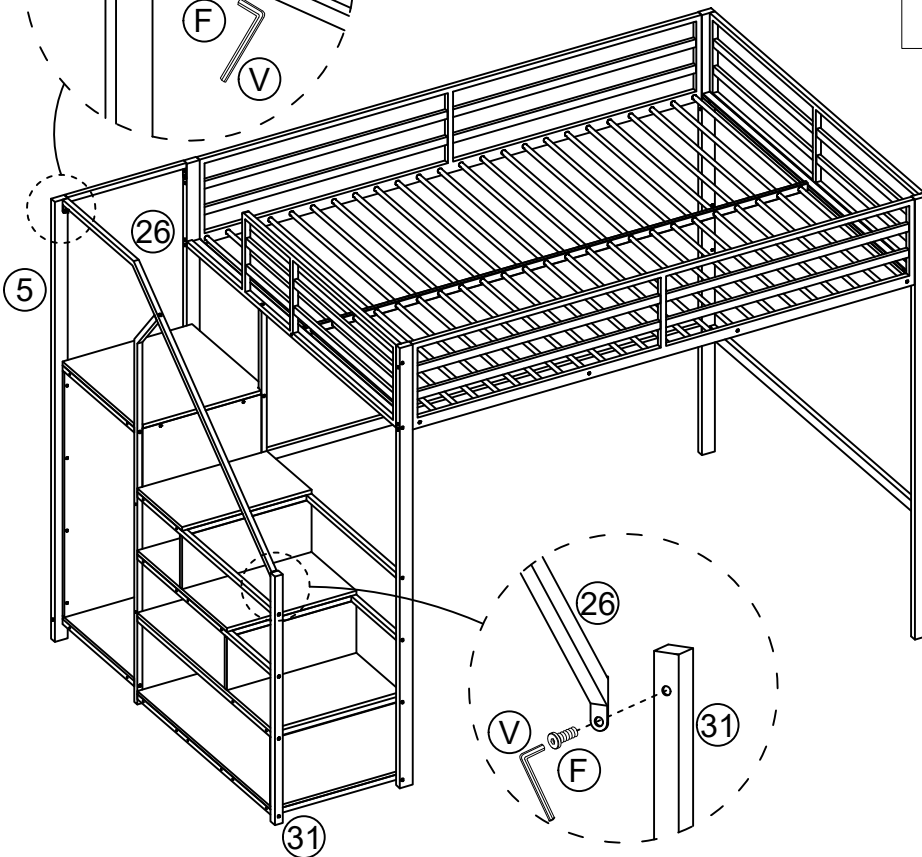



M8*20mm

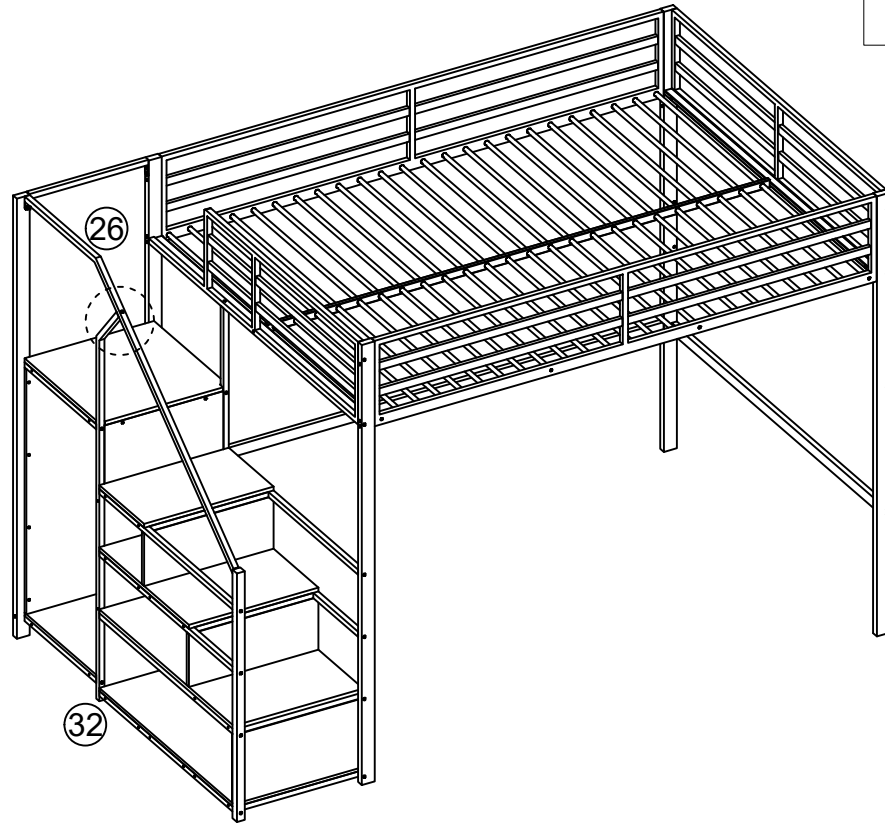

M8*35mm

55

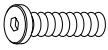

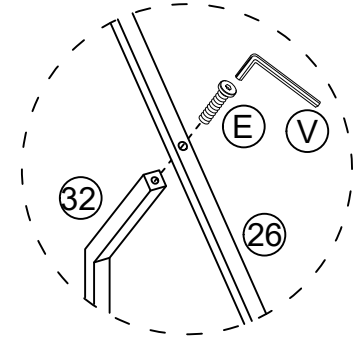

 M8×35mm	 M5
(E) × 1PC	(V) × 1PC

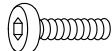
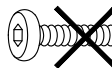

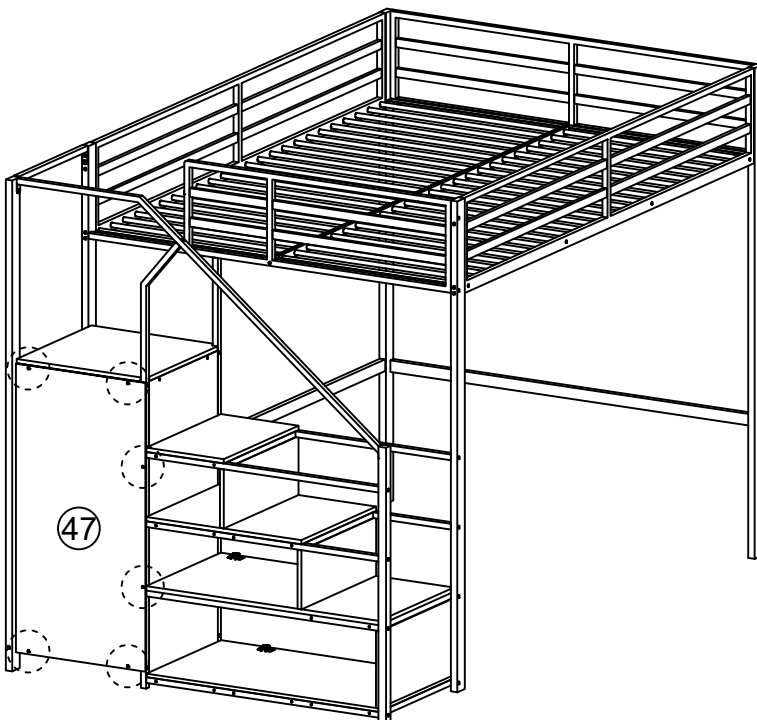

 M8*35mm
 M8*40mm

56



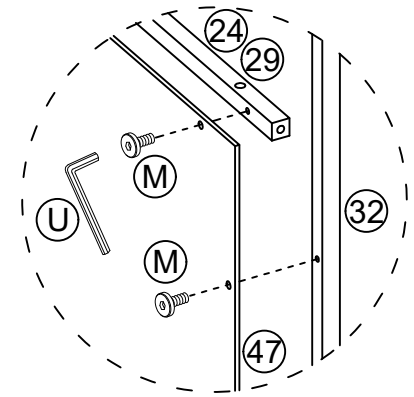

 M6*15mm	 M4
(M) × 6PCS	(U) × 1PC

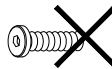



 M6*15mm
 M6*30mm

57

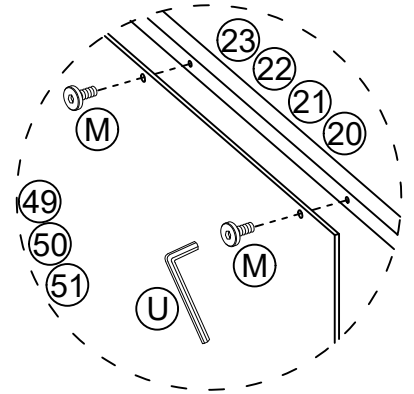
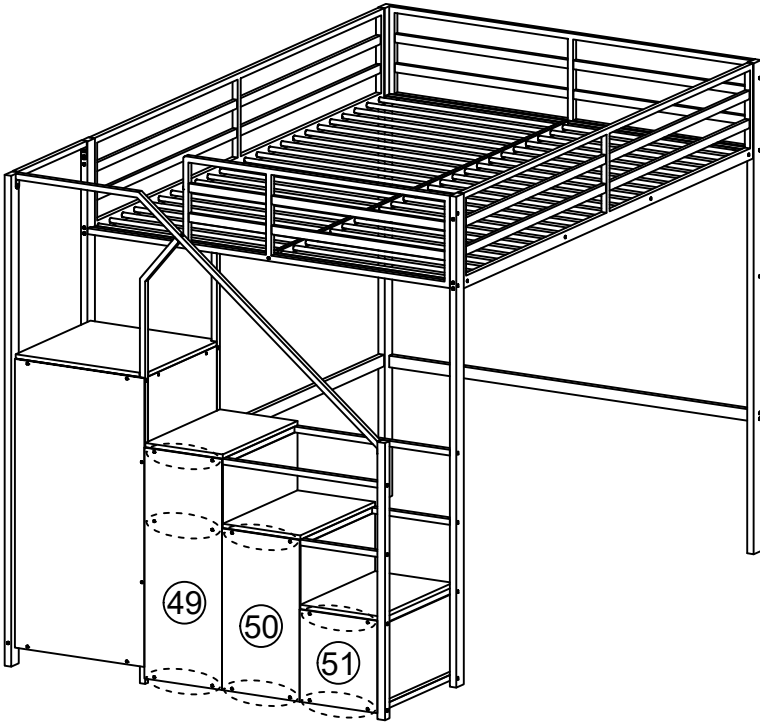
	
M6*15mm	M4
(M) × 14PCS	(U) × 1PC



	M6*15mm
	M6*30mm

58

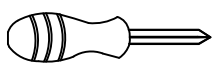
	
M3.5*14mm	
(R) × 6PCS	(W) × 1PC

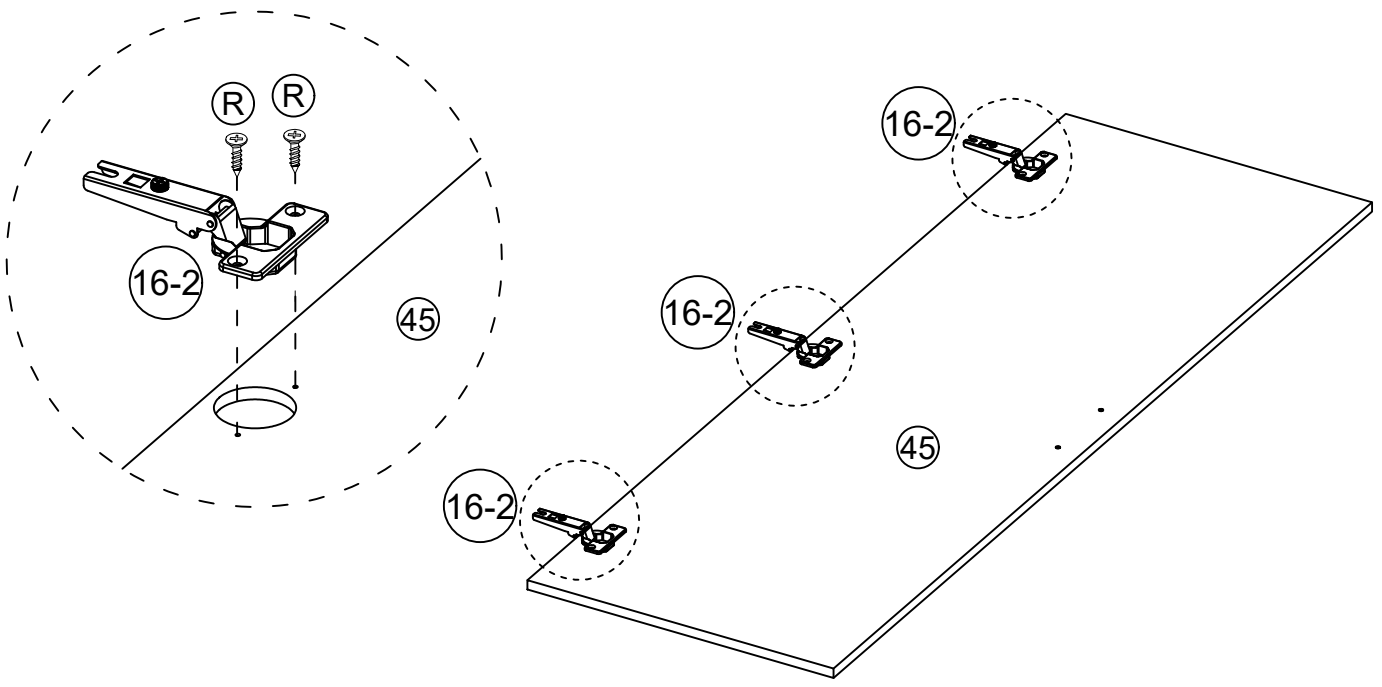

59



M4×20mm



(P)×2PCS

(W)×1PC

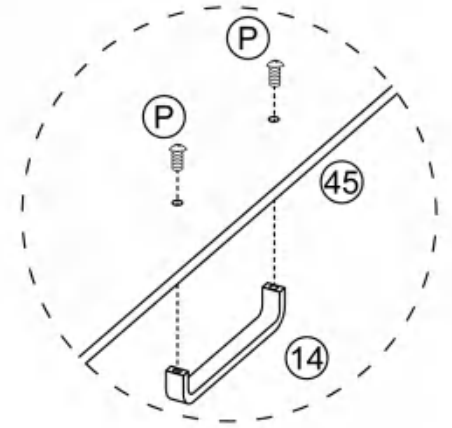
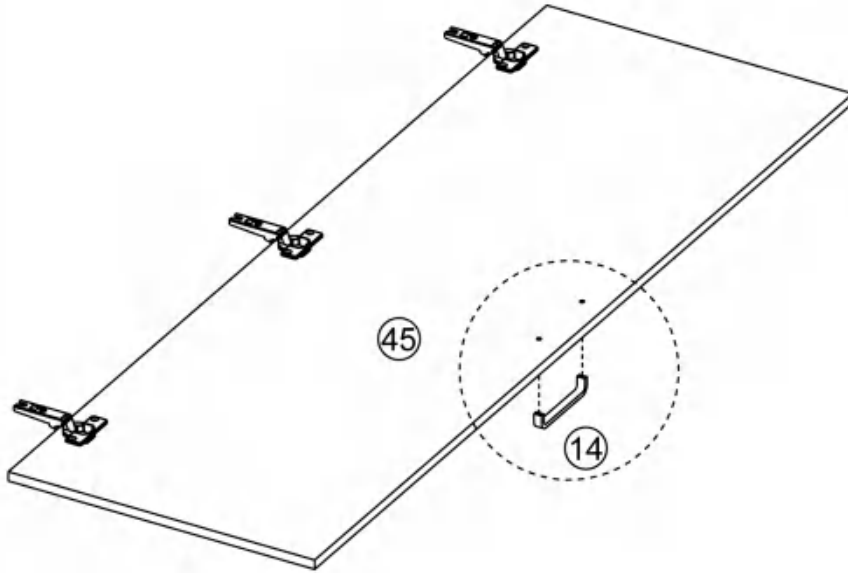

M4*20mm



M4*16mm

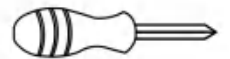

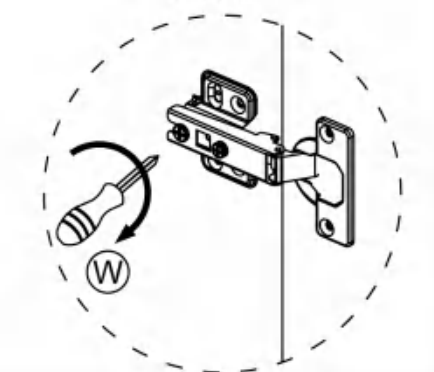
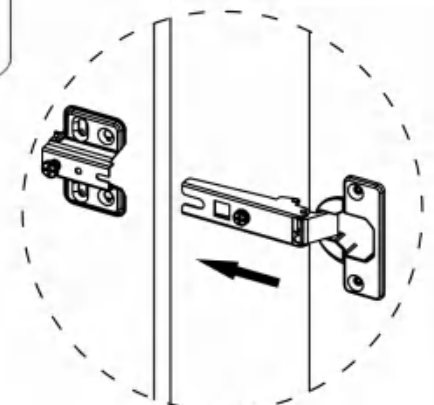
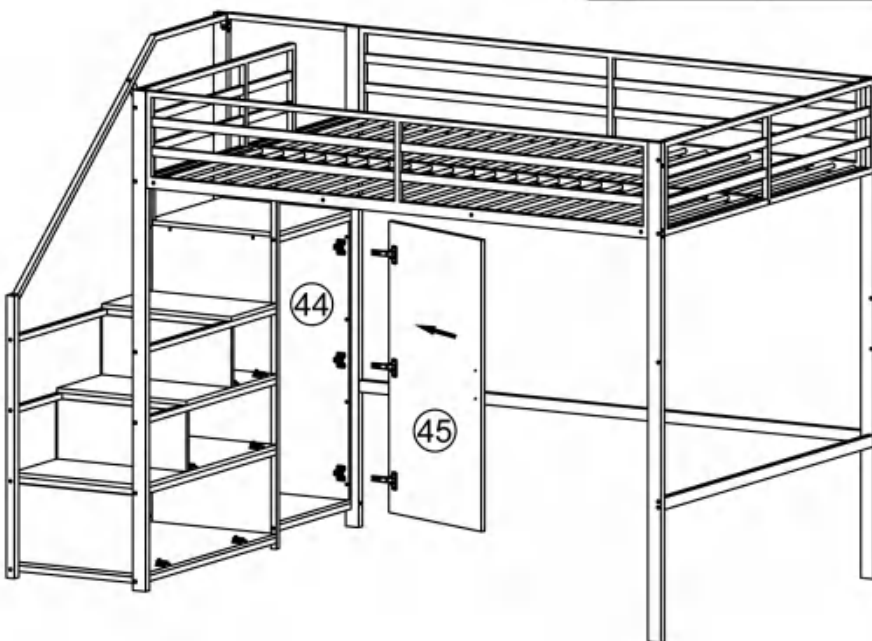
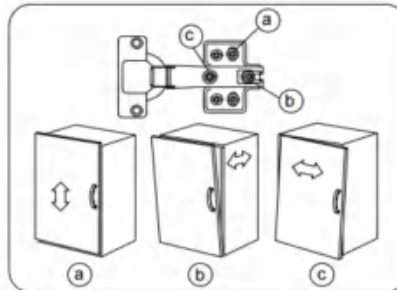

(W)×1PC

60

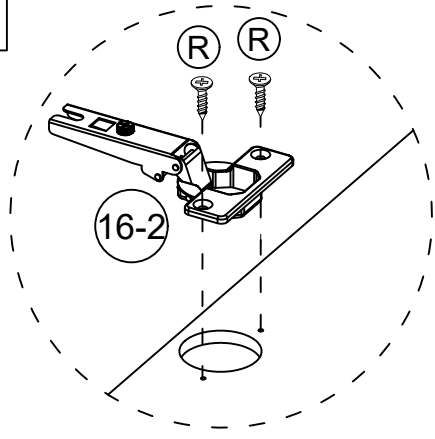

61



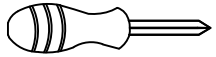

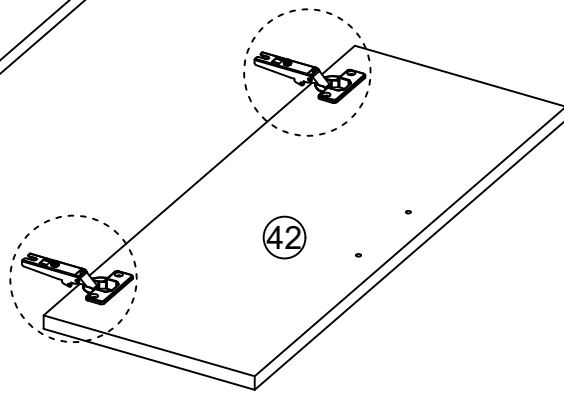
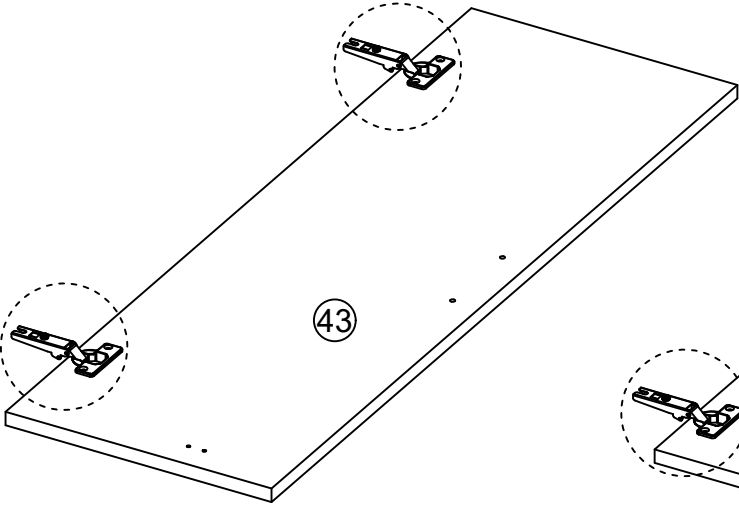
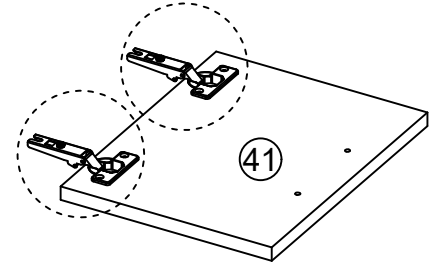
 M3.5×14mm	
(R)×12PCS	(W)×1PC



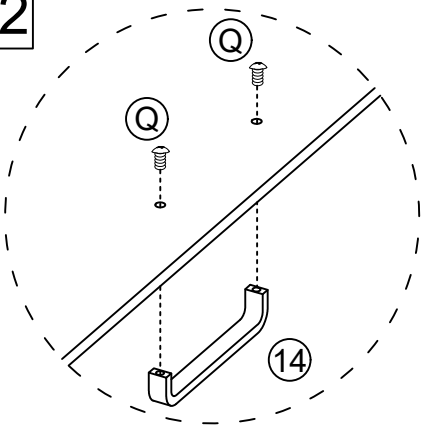

62

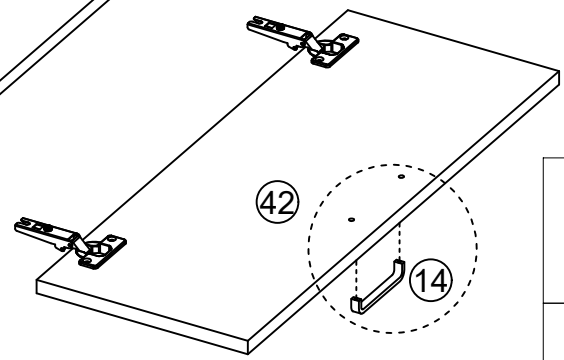
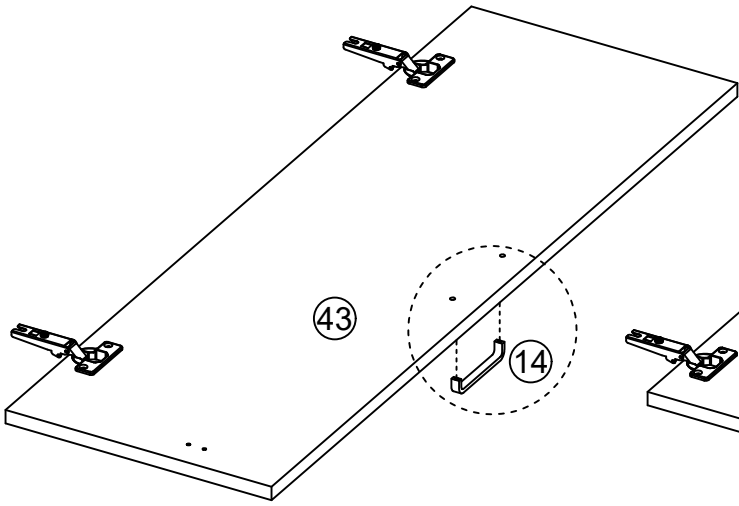
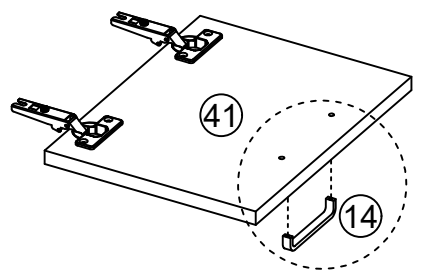

 M4×16mm	
(Q)×6PCS	(W)×1PC



 M4*16mm
 M4*20mm

63

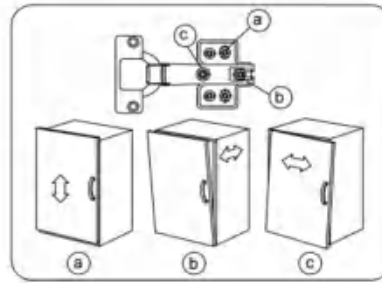

W × 1PC

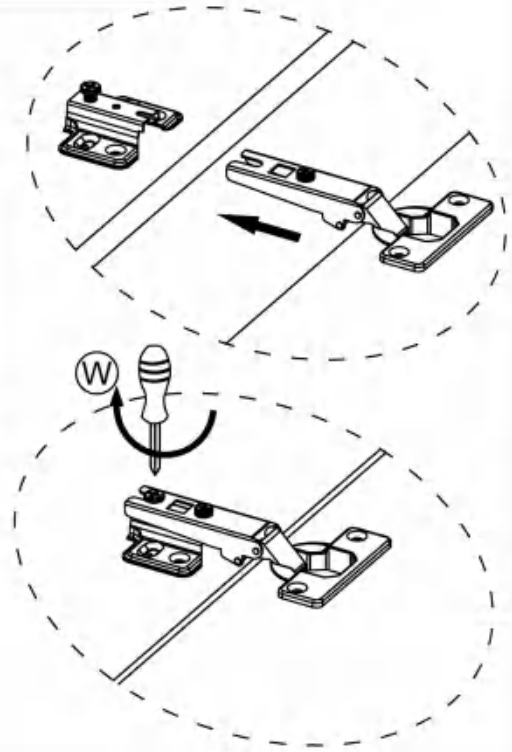
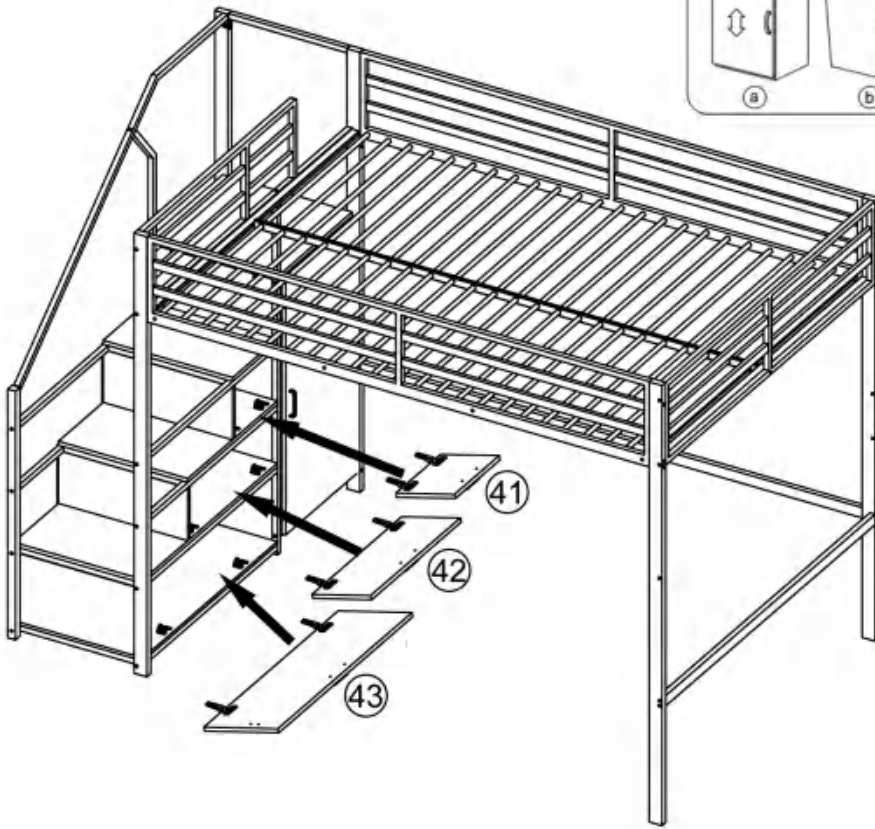

64



M6×15mm

M × 2PCS

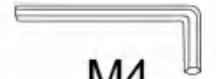

M4

U × 1PC

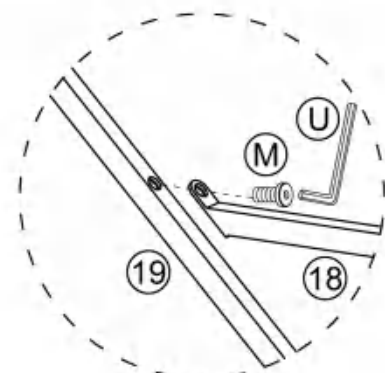
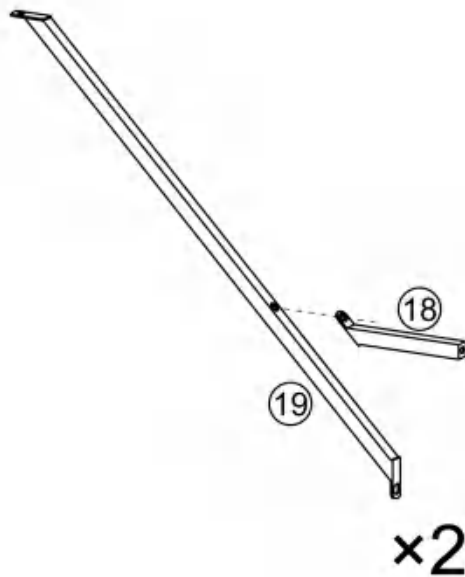

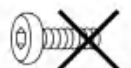

M6×15mm





M6×25mm

65

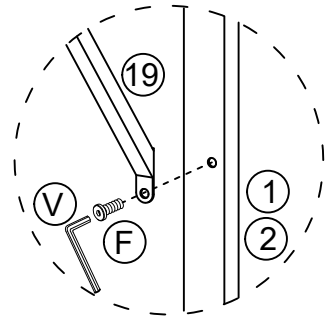
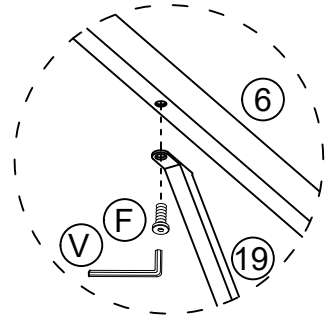
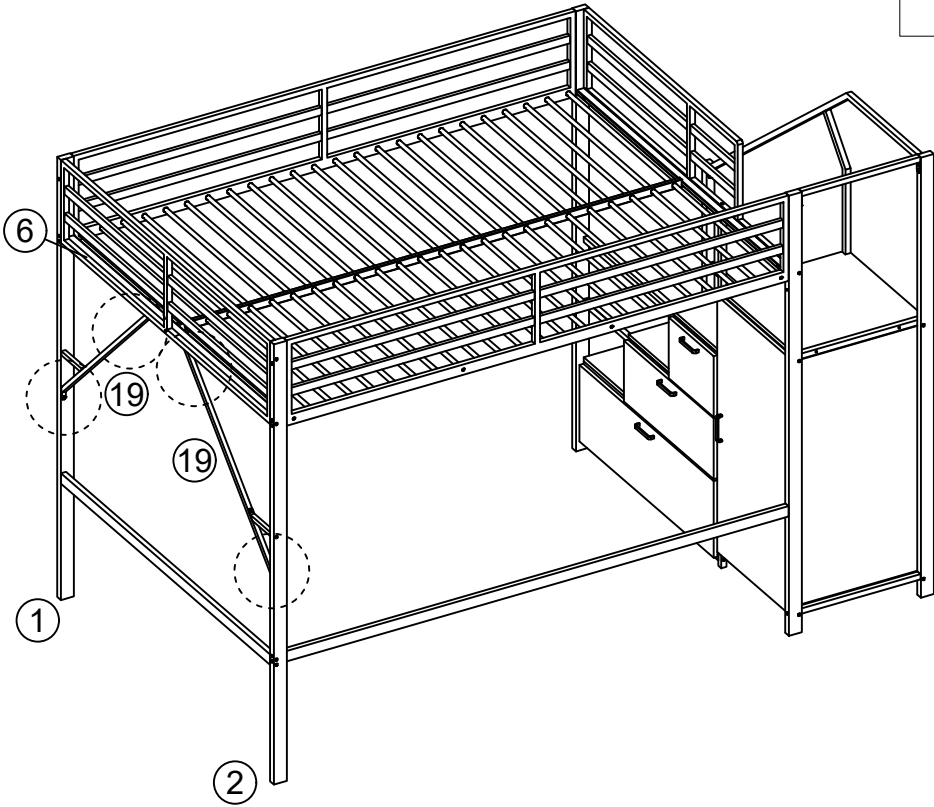
 M8×20mm	 M5
ⓕ×4PCS	Ⓥ×1PC



66

 M6×40mm	 M4
Ⓚ×2PCS	Ⓤ×1PC

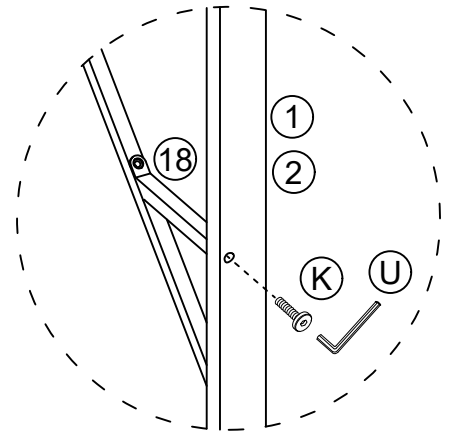
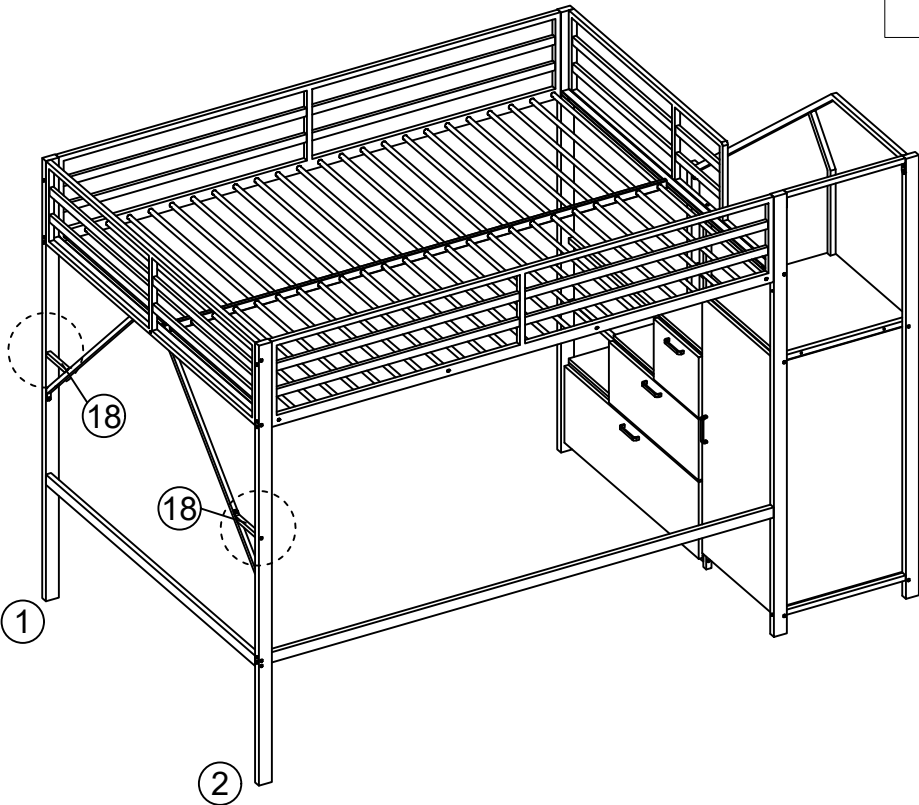

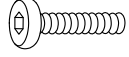
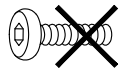
 M6×40mm
 M6×30mm

67



M4×12mm

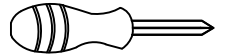

(X) × 4PCS

(W) × 1PC

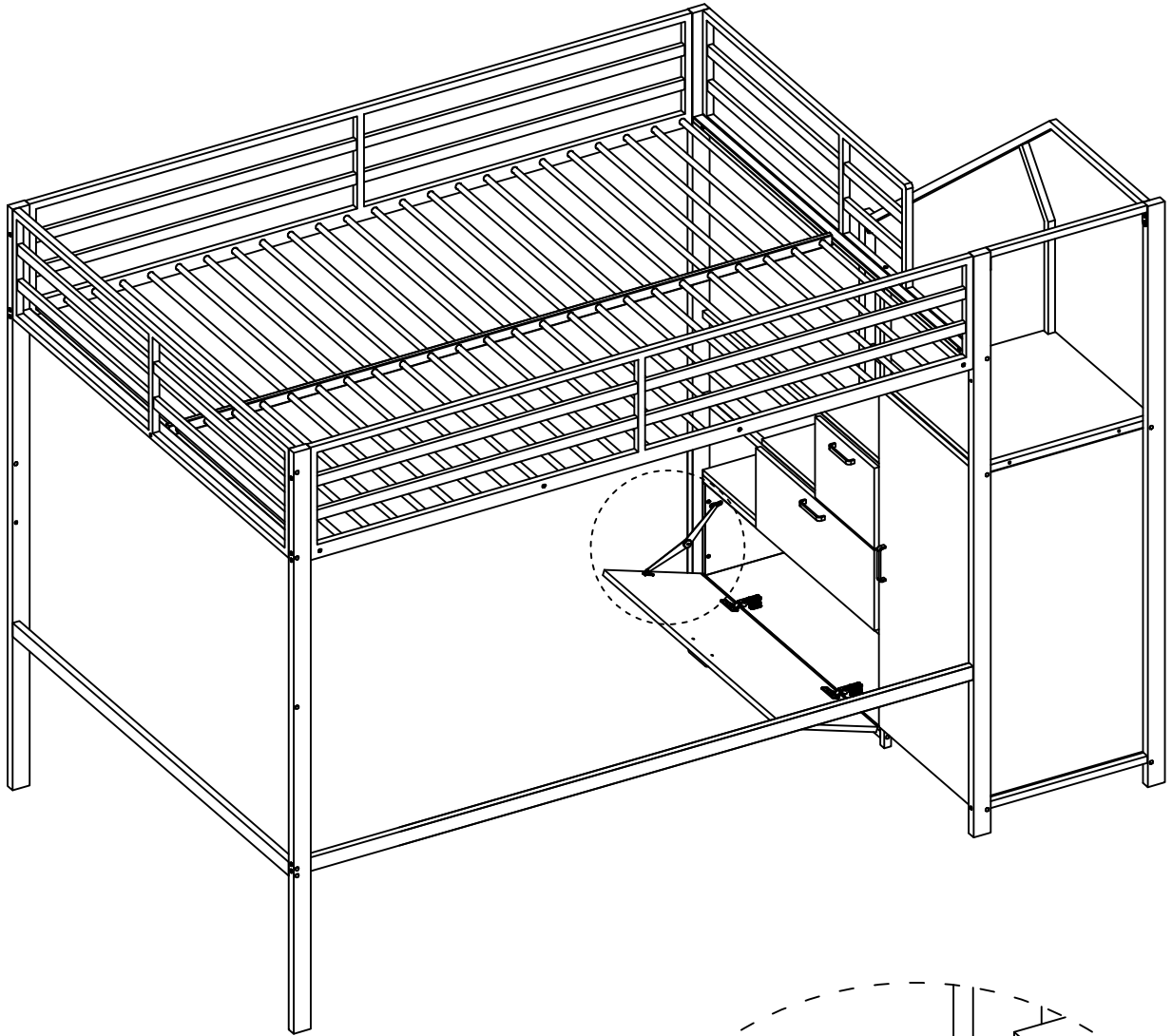

(17)

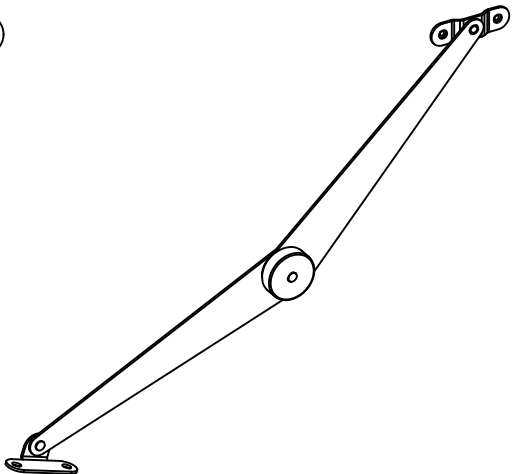

(17)

(W)

(X)

(X)





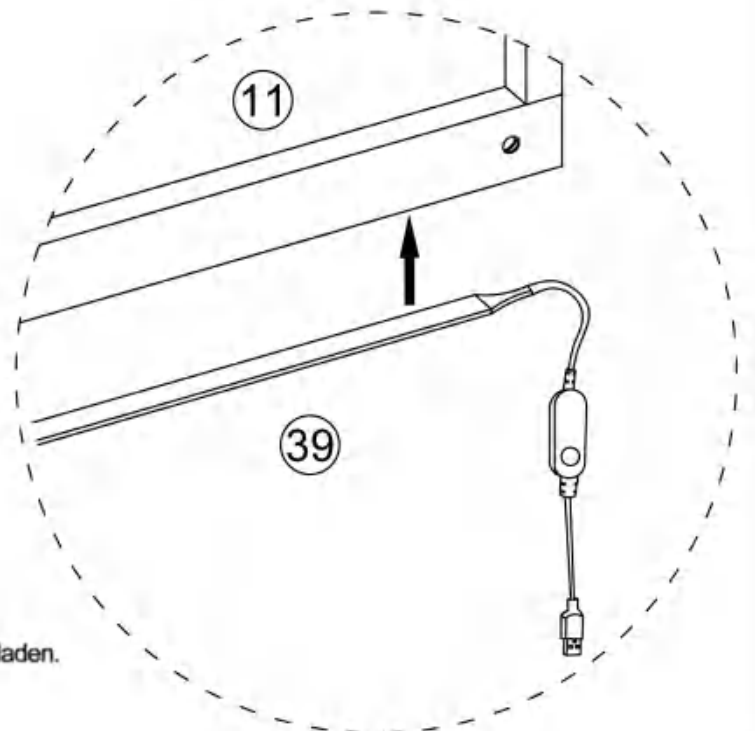
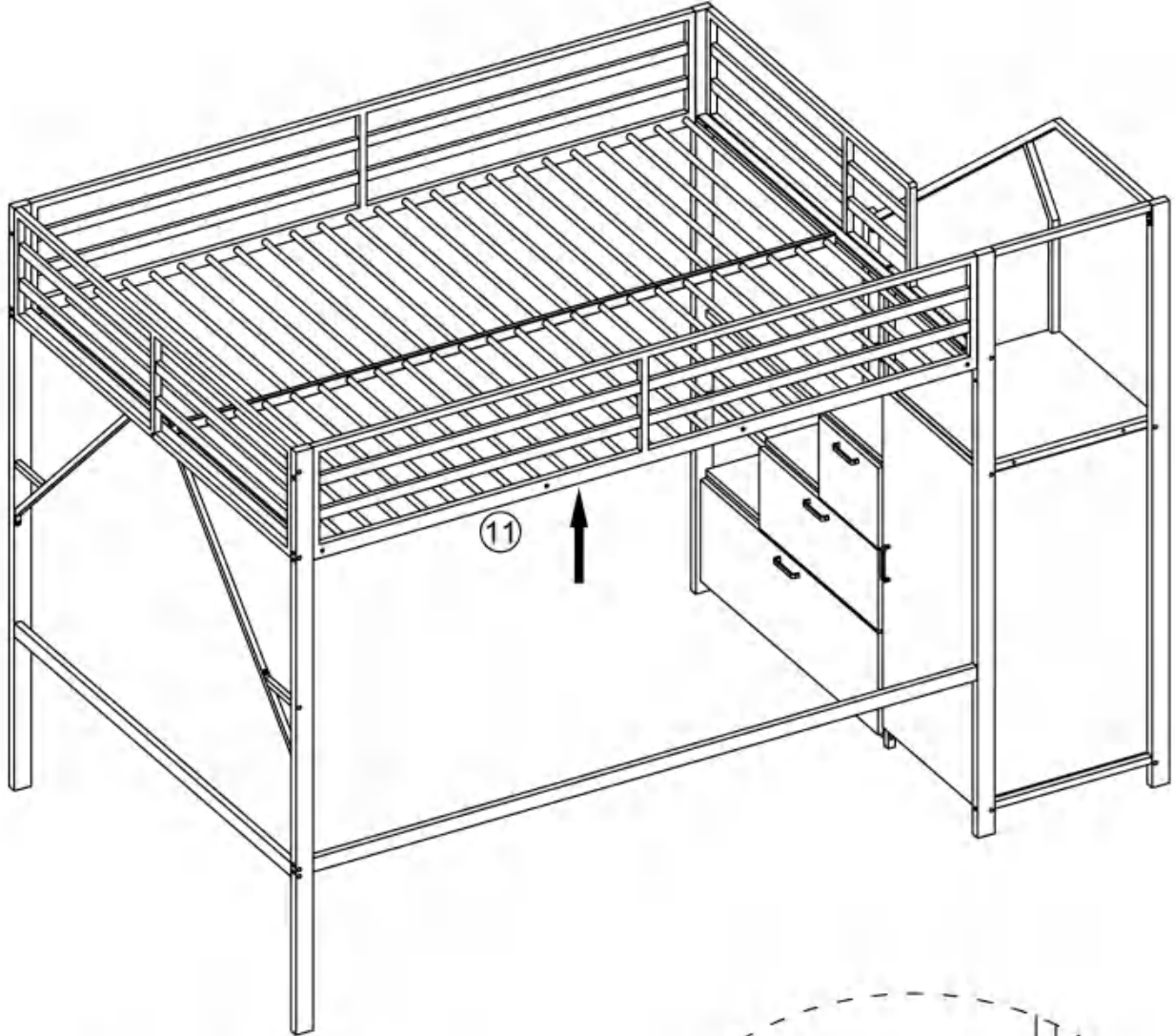
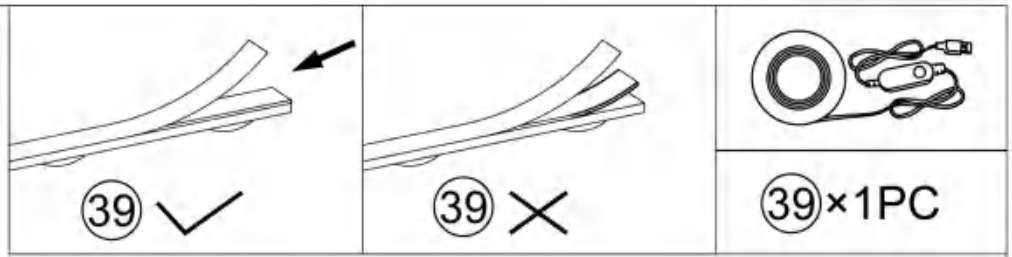



(38)

(43)

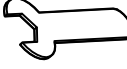
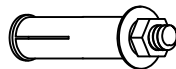
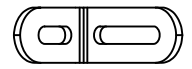

EN: Scan to download App control the Led light.
 DE: Scannen, um die App zum Steuern des LED-Lichts herunterzuladen.
 FR: Scanner pour télécharger App contrôler la lumière Led.

69

 M4	 M6×15mm			
Ⓚ×1PC	Ⓜ×2PCS	Ⓝ×1PC	Ⓛ×2PCS	Ⓜ×2PCS
		 Ⓛ5	 Ⓛ4	 Ⓛ3
			 Ⓛ2	 Ⓛ1

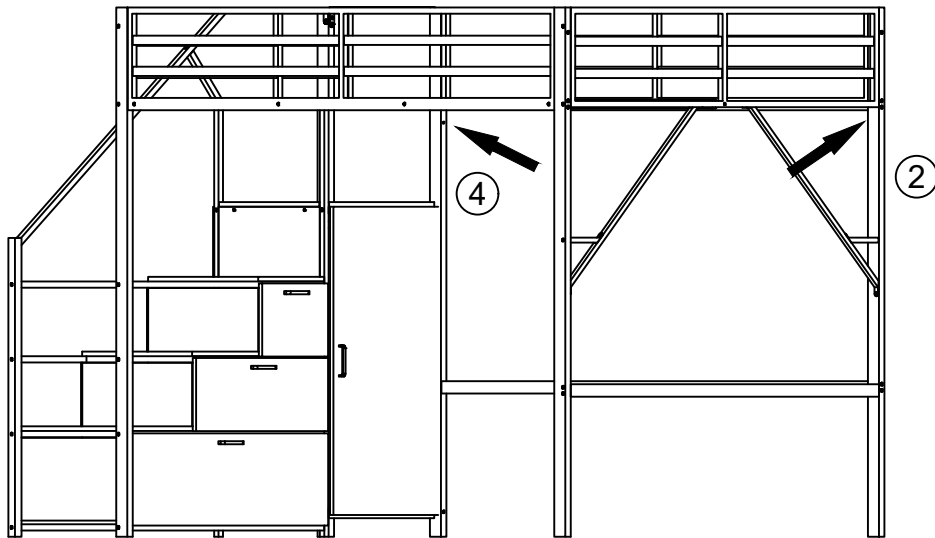
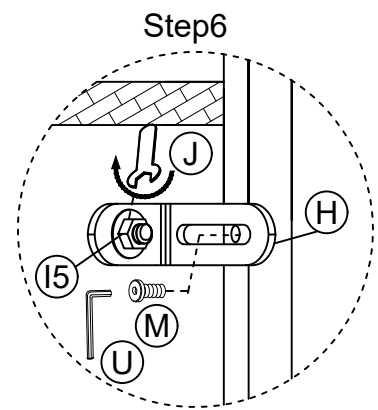
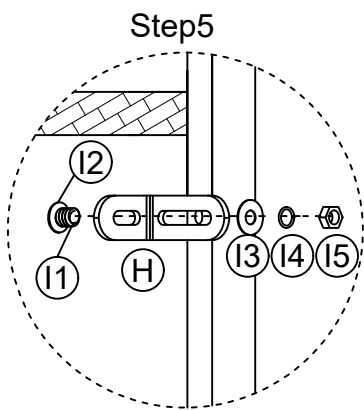
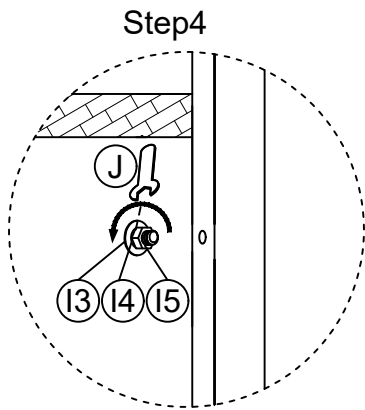
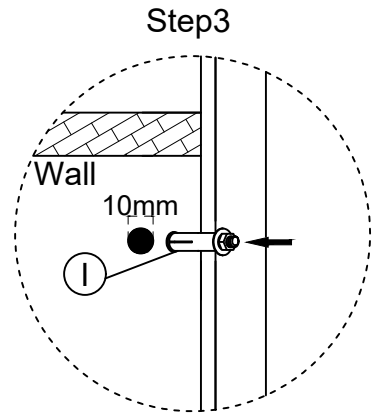
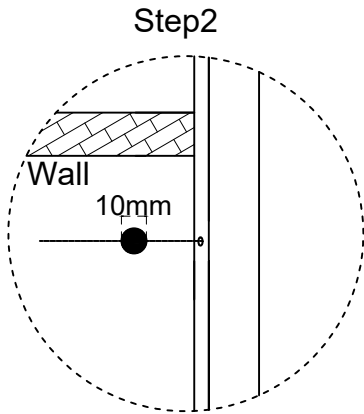
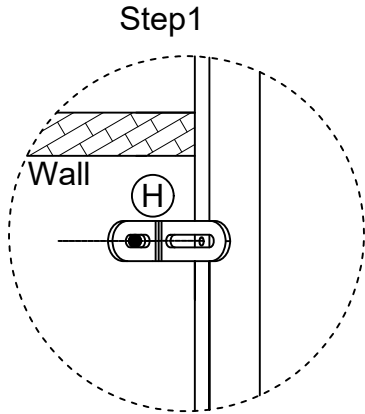

EU DECLARATION OF CONFORMITY

1. Product model/product:

HZY-5050RGB-30D-5V Lamp strip, DC5V, 2.5/meter

2. Name and address of the manufacturer:

Shenzhen Hongzhengyu Technology Co., Ltd

A, 5th Floor, Building 3, Haitian Lanyu Industrial Science and Technology Industrial Park, Shiyan Street, Bao'an District, Shenzhen, China

3. This declaration of conformity is issued under the sole responsibility of the manufacturer.

4. Object of the declaration:

HZY-5050RGB-30D-5V Lamp strip (DC5V, 2.5 LEDs/meter) – as identified by the manufacturer's logo "HZY" or "Shenzhen Hongzhengyu" on the product body or packaging.

5. The object of the declaration described above is in conformity with the relevant Union harmonisation legislation:

- EMC Directive 2014/30/EU
- RoHS Directive 2011/65/EU as amended by (EU) 2015/863 and (EU) 2017/2102

6. References to the relevant harmonised standards used:

- EN IEC 55015:2019+A1:2020
- IEC 61547:2020
- IEC 62321-1:2013, IEC 62321-3-1:2013, IEC 62321-4:2013/AMD1:2017, IEC 62321-5:2013, IEC 62321-6:2015, IEC 62321-7-1:2015, IEC 62321-7-2:2017, IEC 62321-8:2017

7. Additional information:

Use correctly according to the instruction.

8. Signed for and on behalf of:

Shenzhen Hongzhengyu Technology Co., Ltd

Place and date of issue:

Shenzhen, 31 March 2026

Name, function

Xia Xianming General Manager

Signature:



Letter of Authorisation for Use of EU DoC

Date: 31 March 2026

Subject: Authorisation to Use EU Declaration of Conformity for Model YH-358

This letter authorises any entity that lawfully possesses units of model YH-358 LED controller (5V) manufactured by Dongguan Yihong Hardware Electronics Co., Ltd (hereinafter "the Manufacturer") and bearing the Manufacturer's logo ("YH" or "Dongguan Yihong") on the product body to use the EU Declaration of Conformity (DoC) issued by the Manufacturer for that product, under the following conditions:

1. Scope of Authorisation

This authorisation applies exclusively to units that:

- Are model YH-358;
- Bear the Manufacturer's logo;
- Have not been modified without the Manufacturer's written consent.

2. Validity of Authorisation

This authorisation remains valid as long as the commercial relationship between the Manufacturer and the authorised entity continues, or until the product design or applicable legislation changes. In any case, the authorisation does not transfer to third parties unless expressly agreed in writing.

3. Restrictions

The EU DoC shall not be used for:

- Products manufactured by any third party;
- Products without the Manufacturer's logo;
- Any purpose other than demonstrating conformity of the specific units described above.

4. Liability

The Manufacturer assumes no responsibility for misuse of the EU DoC beyond the scope defined herein. Unauthorised use may result in legal action.

Signed for and on behalf of:

Dongguan Yihong Hardware Electronics Co., Ltd

Name, function:

Wenfeng Zeng, General Manager

Signature:



EU DECLARATION OF CONFORMITY

1. Product model / product:

YH-358 LED controller, 5V

2. Name and address of the manufacturer:

Dongguan Yihong Hardware Electronics Co., Ltd

Room 1106, No.2, Shangheng Road, Chang'an Town, Dongguan, China

3. This declaration of conformity is issued under the sole responsibility of the manufacturer.

4. Object of the declaration:

YH-358 LED controller (5V DC input) – as identified by the manufacturer's logo "YH" or "Dongguan Yihong" on the product body.

5. The object of the declaration described above is in conformity with the relevant Union harmonisation legislation:

- Radio Equipment Directive (RED) 2014/53/EU
- RoHS Directive 2011/65/EU & Commission Delegated Directive (EU) 2015/863

6. References to the relevant harmonised standards used:

- EN IEC 62368-1:2024+A11:2024
- ETSI EN 301 489-1 V2.2.3 (2019-11)
- ETSI EN 301 489-17 V3.3.0 (2024-07)
- ETSI EN 300 328 V2.2.2 (2019-07)
- EN IEC 62311:2020, EN 50665:2017
- IEC 62321-1:2013, IEC 62321-2:2021, IEC 62321-3-1:2013, IEC 62321-3-2:2020, IEC 62321-4:2013+AMD1:2017, IEC 62321-5:2013, IEC 62321-6:2015, IEC 62321-7-1:2015, IEC 62321-7-2:2017, IEC 62321-8:2017

7. Additional information:

Use according to the manufacturer's instruction.

8. Signed for and on behalf of:

Dongguan Yihong Hardware Electronics Co., Ltd

Place and date of issue:

Dongguan, 31 March 2026

Name, function:

Wenfeng Zeng, General Manager

Signature:

