

# N625P419182

# N625P419183

Product manual  
Gebrauchsanweisung  
Manuel du produit  
Manual del producto  
Manuale del prodotto

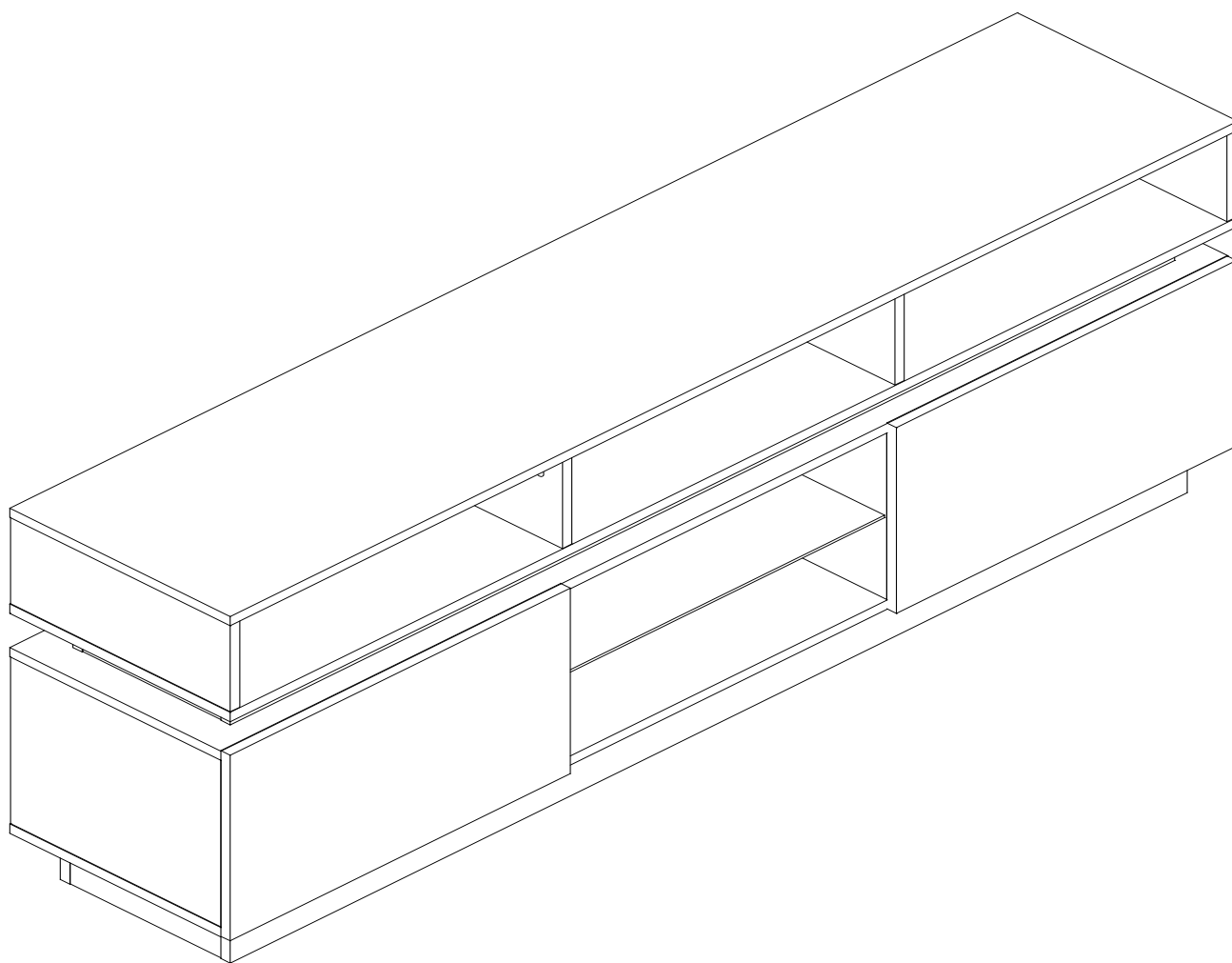

EN:Our product will be delivered to you in 2 packages.  
The delivery times of these 2 packages may differ,  
please be patient and thank you for your understanding.

FR:Notre produit vous sera livré en 2 colis.

Les délais de livraison de ces 2 colis peuvent différer,  
soyez patient et merci de votre compréhension.

DE:Unser Produkt wird Ihnen in 2 Paketen geliefert.

Die Lieferzeiten dieser 2 Paketekonnenabweichen, bitte haben  
Sie etwas Geduld und vielen Dank für Ihr Verständnis.

IT:I nostri prodotti vengono trasportati in due pacchetti.

I tempi di consegna dei due pacchetti sono diversi: abbiate  
pazienza e vi ringrazio per la vostra comprensione

ES:Nuestro producto se entrega en dos paquetes.

El tiempo de entrega de estos dos paquetes es diferente. Por  
favor, sea paciente. Gracias por su comprensión.

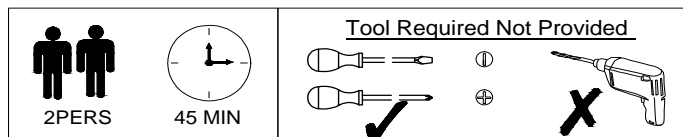

Points de collecte sur [www.quefairedemesdechets.fr](http://www.quefairedemesdechets.fr)  
Privilégiez la réparation ou le don de votre appareil !

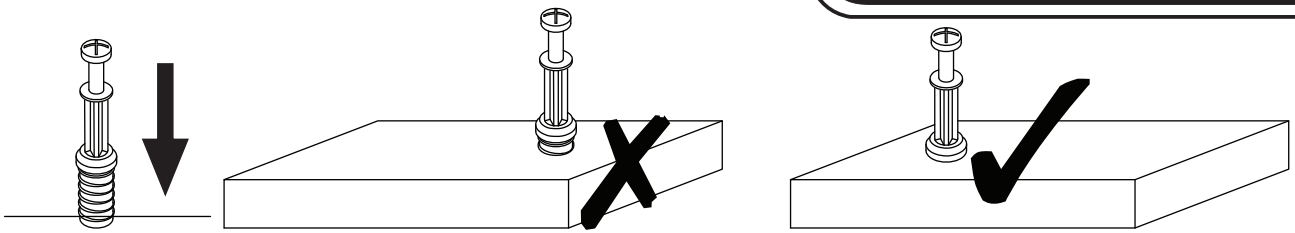

**EN\_QUICKFIT:** Tighten quickfit until shoulder is flush with panel. Do not overtighten or undertighten.

**FR\_RACCORD RAPIDE:** Faites serrer le raccord rapide jusqu'à ce que l'épaule soit parfaitement encastré dans le panneau. Il ne faut ni trop serrer ni insuffisamment serrer.

**ES\_QUICKFIT:** Apriete quickfit hasta que el hombro se descargue con el panel. NO lo sobreapriete ni lo apriete poco.

**DE\_QUICKFIT:** Ziehen Sie den Quickfit fest, bis die Schulter mit der Platte bündig ist. Bitte nicht zu fest oder zu schwach anziehen.

**IT\_MONTAGGIO RAPIDO:** Stringere il montaggio rapido fino a quando la spalla è a filo con il pannello, non stringere troppo o troppo poco.

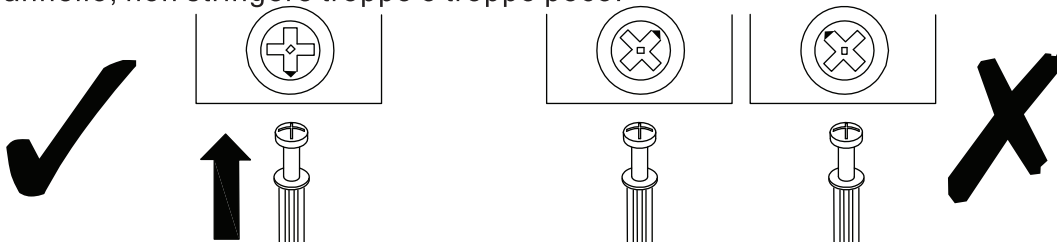

**EN\_CAM LOCK:** When fitting cam lock, ensure starting position is correct before you insert connecting quickfit.

**FR\_SERRURE BATTEUSE:** Avant d'insérer la serrure batteuse, veillez à la bonne orientation avant d'insérer le raccord rapide.

**ES\_CIERRE DE LA CÁMARA:** Cuando instale el cierre de la cámara, asegúrese de que la posición de inicio es correcta antes de que inserte el quickfit conector.

**DE\_CAM-LOCK:** Achten Sie bei der Montage des Cam-Locks auf die richtige Ausgangsposition, bevor Sie den Quickfit einsetzen.

**IT\_BLOCCAGGIO A CAMMA:** Quando si monta il bloccaggio a camma, assicurarsi che la posizione iniziale sia corretta prima di inserire il montaggio rapido di collegamento.

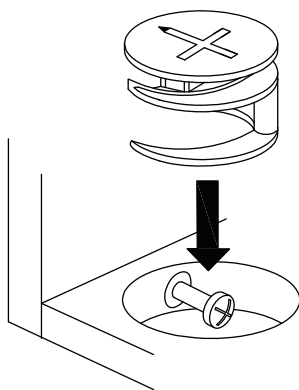

**EN\_Quickfit head** should be in the centre of the cam lock when the two panels are joined.

Cam lock should be inserted before quickfit.

**FR\_Lorsque** les deux panneaux sont assemblés, la tête du raccord rapide doit reposer au centre de la serrure batteuse.

Il faut insérer la serrure batteuse avant le raccord rapide.

**ES\_El** cabezal del quickfit debe estar en el centro del cierre de la cámara cuando se unan los dos paneles.

Se debe insertar el cierre de la cámara antes que el quickfit.

**DE\_Der** Quickfit-Kopf sollte sich in der Mitte des Cam-Locks befinden, wenn die beiden Platten zusammengefügt sind.

Der Cam-Lock sollte vor dem Quickfit eingesetzt werden.

**IT\_La** testa del montaggio rapido deve trovarsi al centro del bloccaggio a camma quando i due pannelli sono uniti.

Il Bloccaggio a Camma deve essere inserito prima del montaggio rapido.

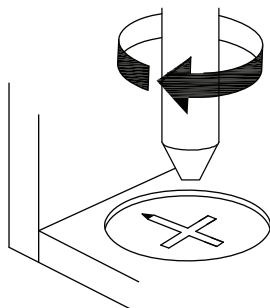

**EN\_Turn** cam lock clockwise to tighten.

**FR\_Faites** tourner la serrure batteuse dans le sens des aiguilles d'une montre pour la resserrer.

**ES\_Gire** el cierre de la cámara en sentido horario para apretarlo.

**DE\_Drehen** Sie den Cam-Lock im Uhrzeigersinn, um ihn festzuziehen.

**IT\_Ruotare** il bloccaggio a camma in senso orario per stringere.

**EN** It may be necessary to adjust the hinges so that the doors align. Use the instructions below as a guide.

**FR** Il est parfois nécessaire d'ajuster les charnières pour un meilleur alignement des portes. Servez-vous des instructions ci-dessous comme guide.

**ES** Puede que sea necesario ajustar los quicios de forma que se alineen las puertas. Use las instrucciones que aparecen debajo como guía.

**DE** Möglicherweise müssen Sie die Scharniere so einstellen, dass die Türen ausgerichtet sind. Verwenden Sie die nachstehenden Anweisungen als Leitfaden.

**IT** Potrebbe essere necessario regolare le cerniere in modo che le porte siano allineate. Per fare ciò attenersi alle istruzioni sottostanti.

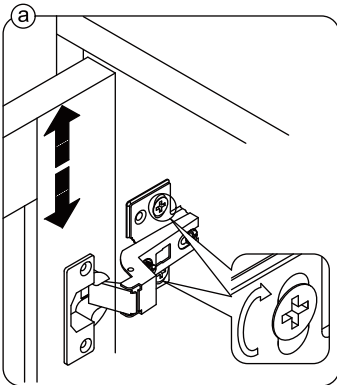

**EN** To adjust the door vertically loosen the screw as shown and move up and down as needed.

**FR** Si vous souhaitez régler la porte **verticalement**, desserrez la vis comme indiqué et déplacez la porte de haut en bas selon les besoins.

**ES** Para ajustar la puerta **verticalmente** afloje el tornillo tal y como se muestra y muévelo hacia arriba o hacia abajo según sea necesario.

**DE** Um die Tür **vertikal** auszurichten, lösen Sie die Schraube wie abgebildet und bewegen Sie sie nach Bedarf nach oben oder nach unten.

**IT** Per allineare la porta **verticalmente** allentare la vite come mostrato e spostarla in alto o in basso secondo necessità.

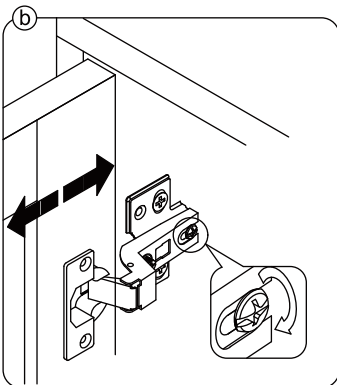

**EN** To adjust the gap from the door to the main frame turn the screw clockwise or anti-clockwise as needed.

**FR** Si vous souhaitez ajuster l'**écart** entre la porte et le cadre principal, tournez la vis dans le sens des aiguilles d'une montre ou dans le sens inverse, si nécessaire.

**ES** Para ajustar el **espacio** desde la puerta al marco principal, gire el tornillo en sentido horario o antihorario, según se necesite.

**DE** Um den **Abstand** von der Tür zum Hauptrahmen auszurichten, drehen Sie die Schraube je nach Bedarf im oder gegen den Uhrzeigersinn.

**IT** Per regolare lo **spazio** tra la porta e il telaio principale, avvitare o svitare la vite secondo necessità.

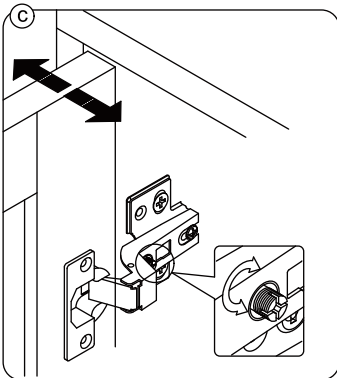

**EN** To adjust the door laterally adjust the screw as shown by turning clockwise or anti-clockwise.

**FR** Si vous souhaitez ajuster la porte **latéralement**, ajustez la vis comme indiqué en tournant dans le sens des aiguilles d'une montre ou dans le sens inverse des aiguilles d'une montre.

**ES** Para ajustar la puerta **lateralmente** ajuste el tornillo tal y como se muestra girándolo en sentido horario y antihorario.

**DE** Um die Tür **seitlich** auszurichten, stellen Sie bitte die Schraube wie abgebildet durch Drehen im oder gegen den Uhrzeigersinn ein.

**IT** Per allineare la porta **lateralmente** regolare la vite come mostrato, avvitarandola o svitarandola.

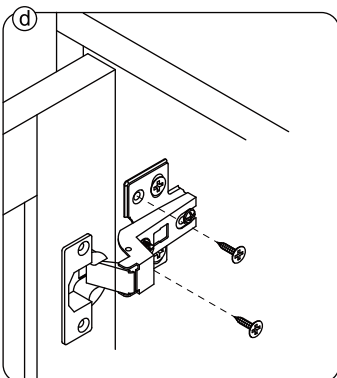

**EN** Please fix other screws

**FR** Merci de serrer les autres vis.

**ES** Fije los demás tornillos

**DE** Befestigen Sie bitte die anderen Schrauben

**IT** Fissare le altre viti

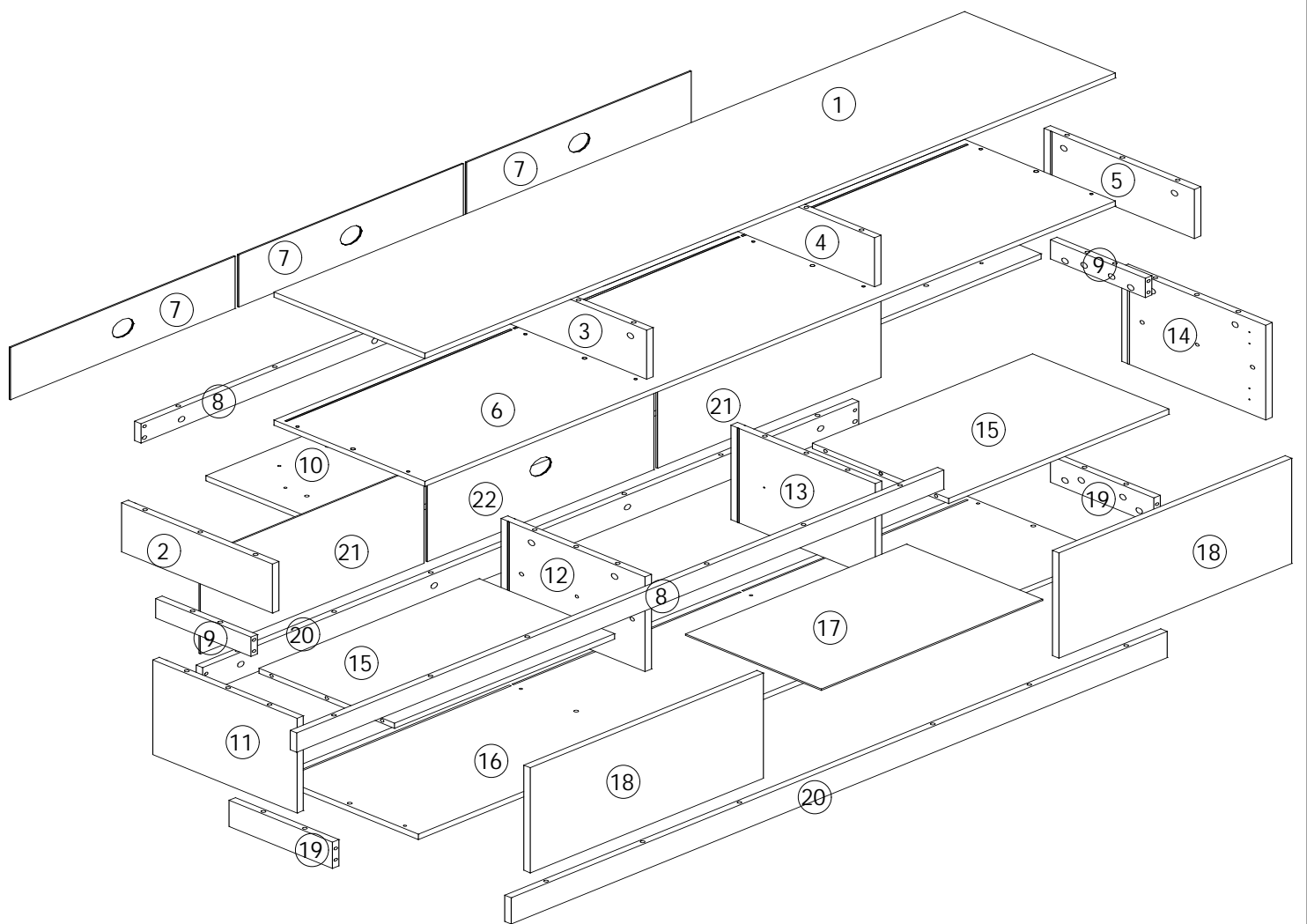

# BOX-1/2 N625P419182

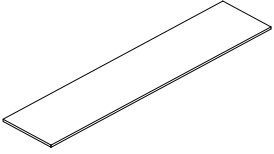
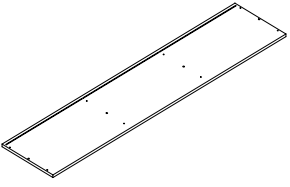
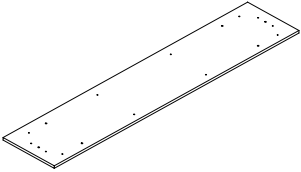
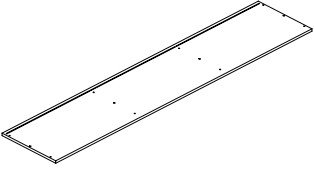
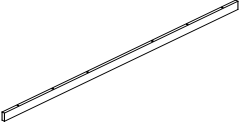
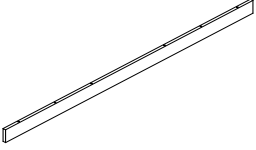
①		1		⑥		1
⑩		1		⑬		1
⑧		2		⑲		2



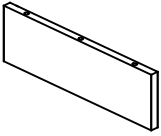
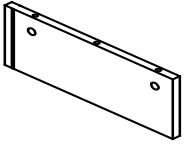
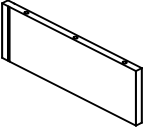
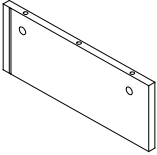
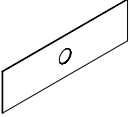
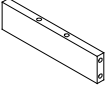
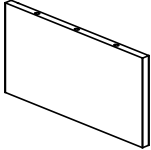
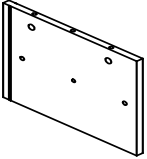
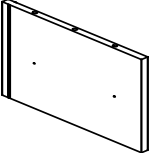
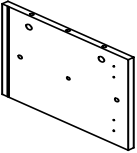



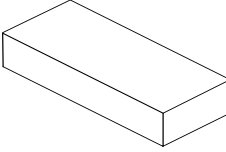







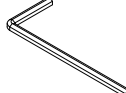

# BOX-2/2 N625P419183

②		1		③		1
④		1		⑤		1
⑦		3		⑨		2
⑪		1		⑫		1
⑬		1		⑭		1

15		2		17		1
18		2		19		2
21		2		22		1

	Hardware kit
---	--------------

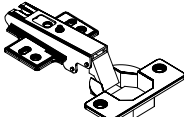
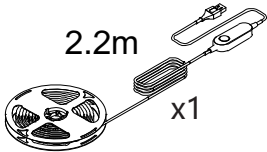
# BOX-2/2 N625P419183

<p>A</p> 	<p>B</p>  <p>φ15*12</p>	<p>C</p>  <p>8*40</p>
<p>56 PCS</p>	<p>56 PCS</p>	<p>42 PCS</p>
<p>D</p>  <p>5*40</p>	<p>E</p>  <p>15*30*2mm</p>	<p>F</p>  <p>3.5*14</p>
<p>28 PCS</p>	<p>4 PCS</p>	<p>70 PCS</p>
<p>G</p> 	<p>H</p> 	<p>I</p>  <p>M3</p>
<p>24 PCS</p>	<p>4 PCS</p>	<p>1 PC</p>
<p>J1</p>  <p>2 PCS</p> <p>J2</p>  <p>2 PCS</p> <p>J3</p>  <p>2 PCS</p> <p>J4</p>  <p>3.5*35</p> <p>2 PCS</p> <p>J5</p>  <p>6*30</p> <p>2 PCS</p> <p>3.5*14</p> <p>2 PCS</p>	<p>K</p>  <p>4 PCS</p>	<p>L</p>  <p>2.2m</p> <p>x1</p> <p>1 PC</p>
<p>M</p>  <p>9 PCS</p>	<p>N</p>  <p>84 PCS</p>	

1

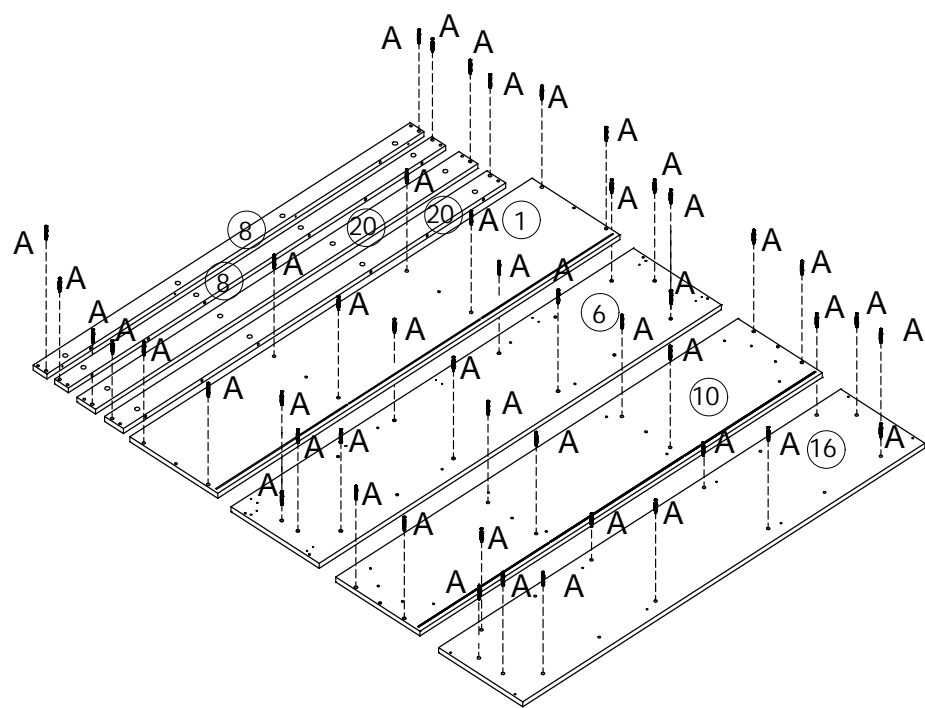
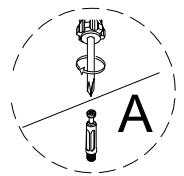

A  48 PCS

2

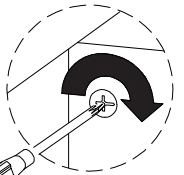
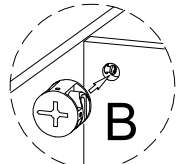
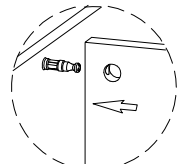
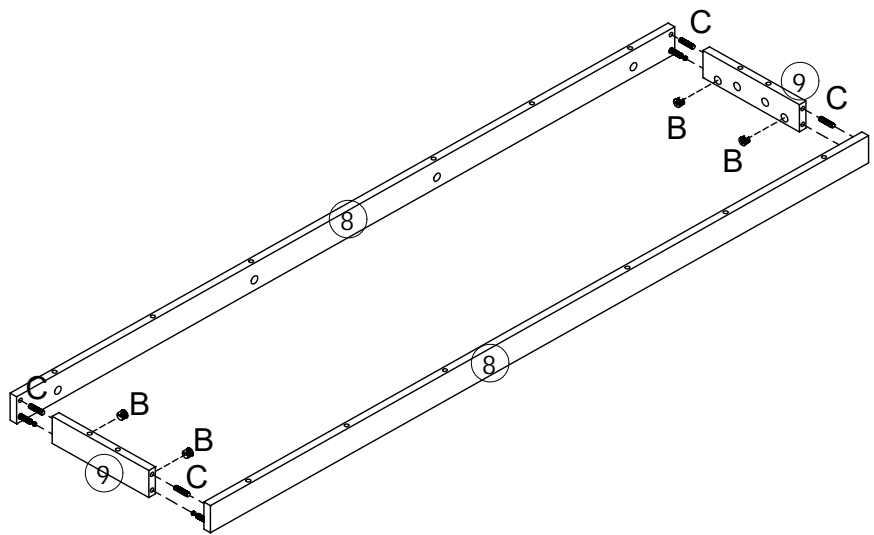



B  4 PCS

C  4 PCS

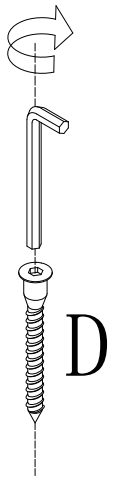
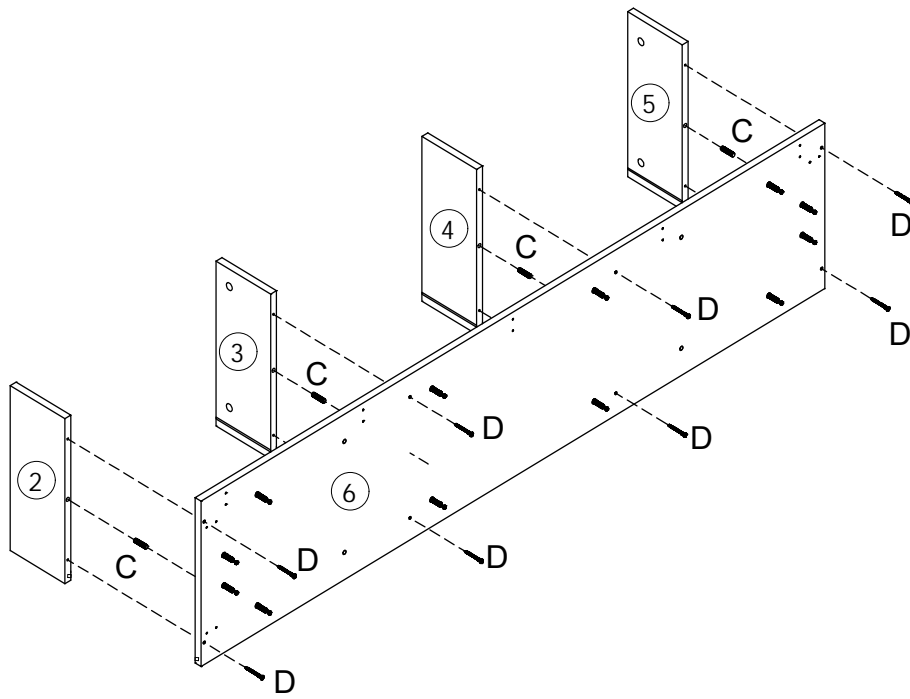

3

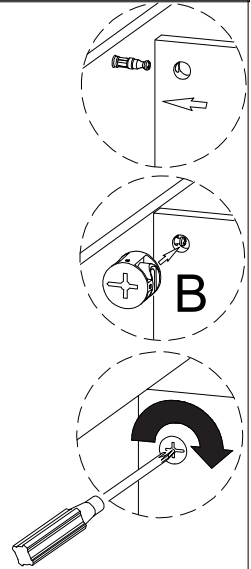
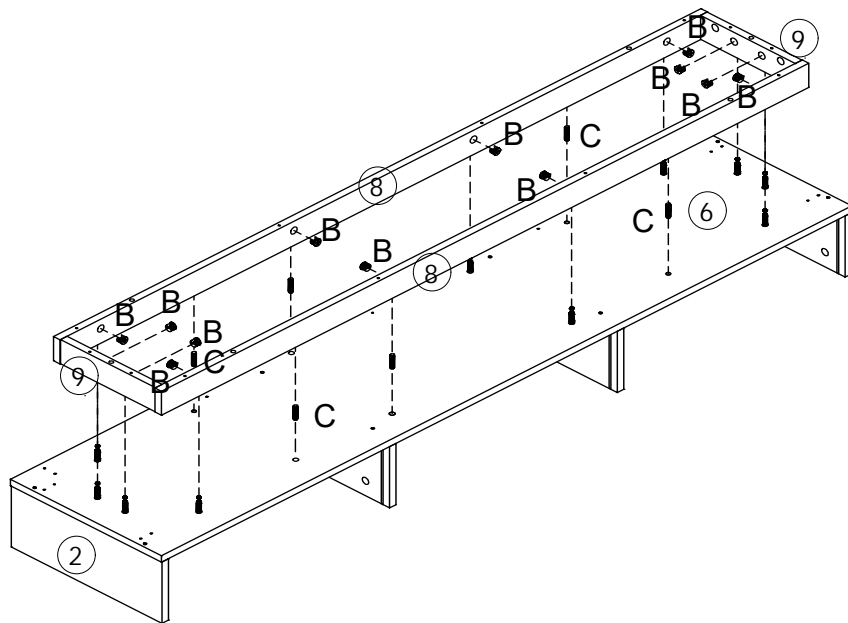

<p>C</p>  <p>4 PCS</p>	<p>D</p>  <p>8 PCS</p>
---	---

4



<p>B</p>  <p>12 PCS</p>	<p>C</p>  <p>4 PCS</p>
--	---

5

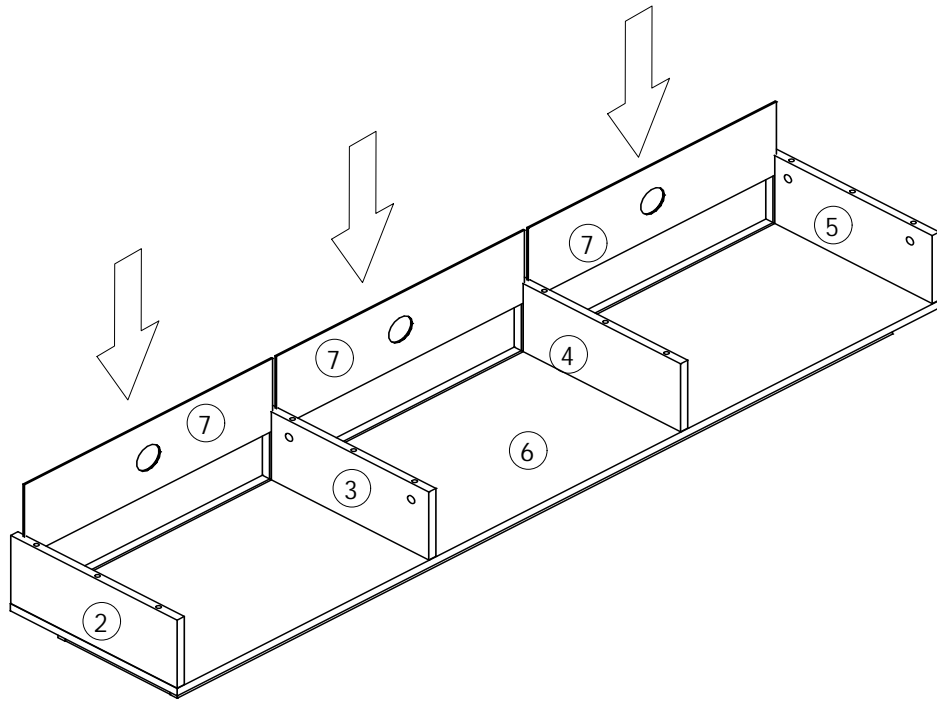

6

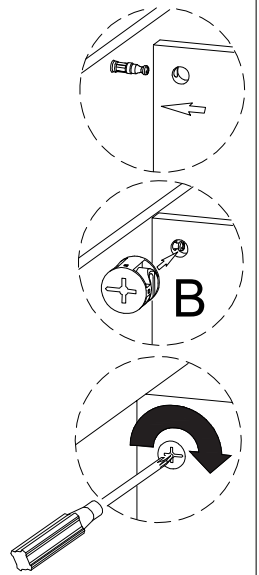
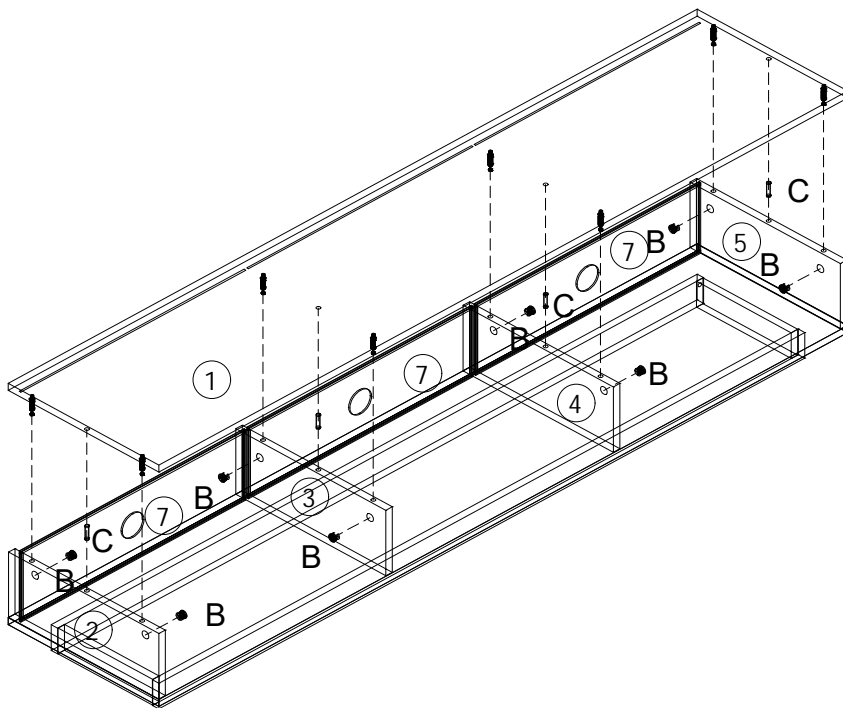

B  8 PCS

C  4 PCS



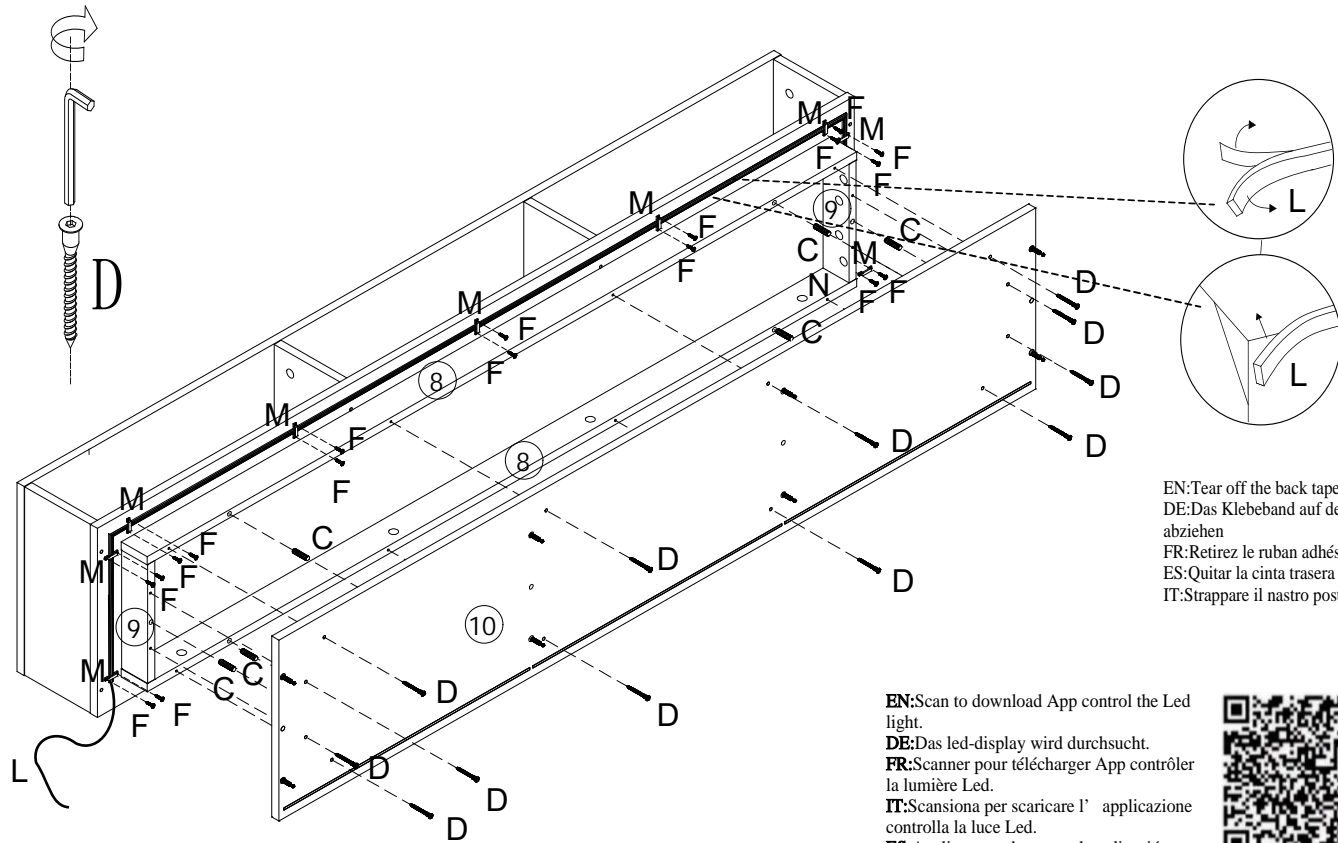

7



EN:Tear off the back tape  
 DE:Das Klebeband auf der Rückseite abziehen  
 FR:Retirez le ruban adhésif arrière  
 ES:Quitar la cinta trasera  
 IT:Strappare il nastro posteriore

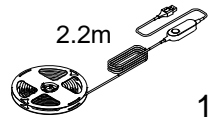

EN:Scan to download App control the Led light.  
 DE:Das led-display wird durchsucht.  
 FR:Scanner pour télécharger App contrôler la lumière Led.  
 IT:Scansiona per scaricare l' applicazione controlla la luce Led.  
 ES:Analice para descargar la aplicación control de la luz Led.

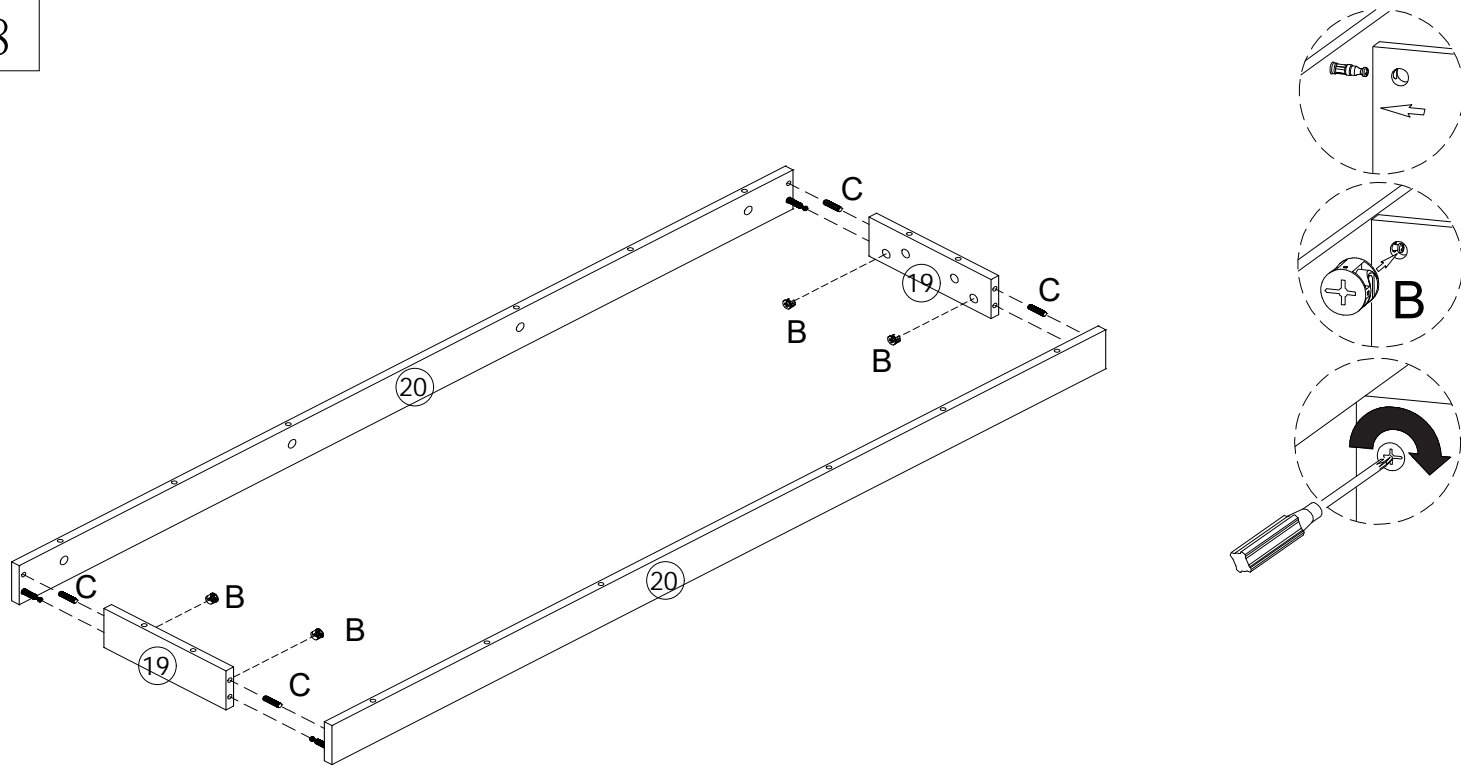

<p>C</p>  <p>6 PCS</p>	<p>D</p>  <p>12 PCS</p>	<p>F</p>  <p>18PCS</p>	<p>L</p>  <p>2.2m 1PC</p>	<p>M</p>  <p>9 PCS</p>
---	--	---	---	---

8



<p>B</p>  <p>4 PCS</p>	<p>C</p>  <p>4 PCS</p>
---	---

9

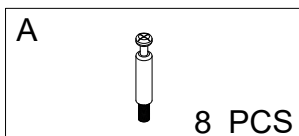
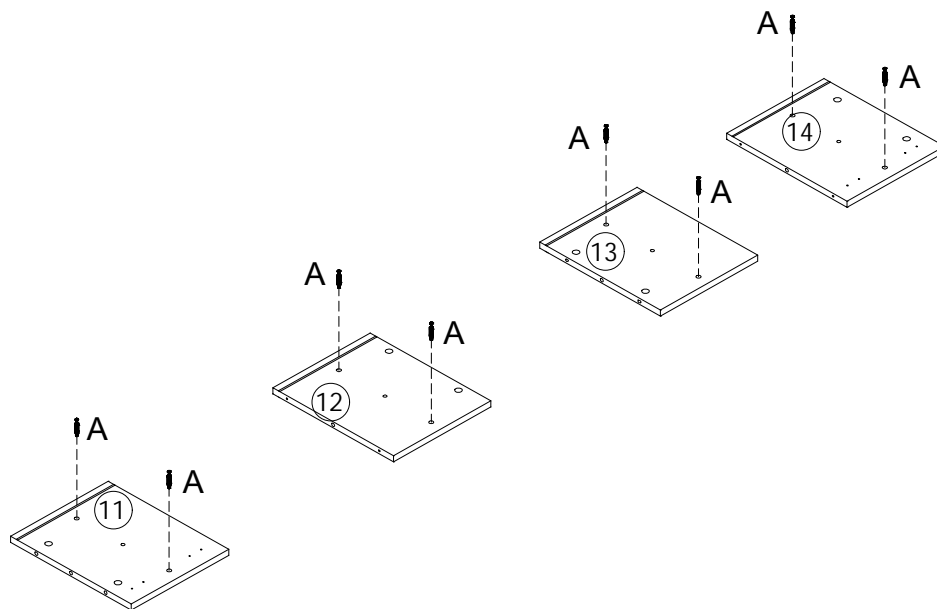
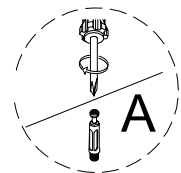

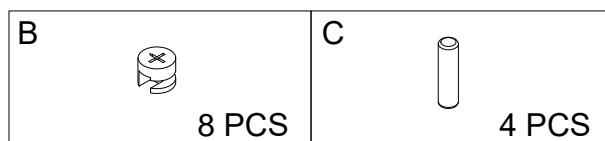
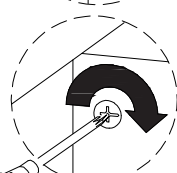
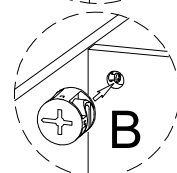
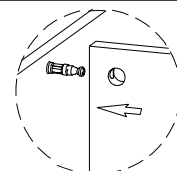
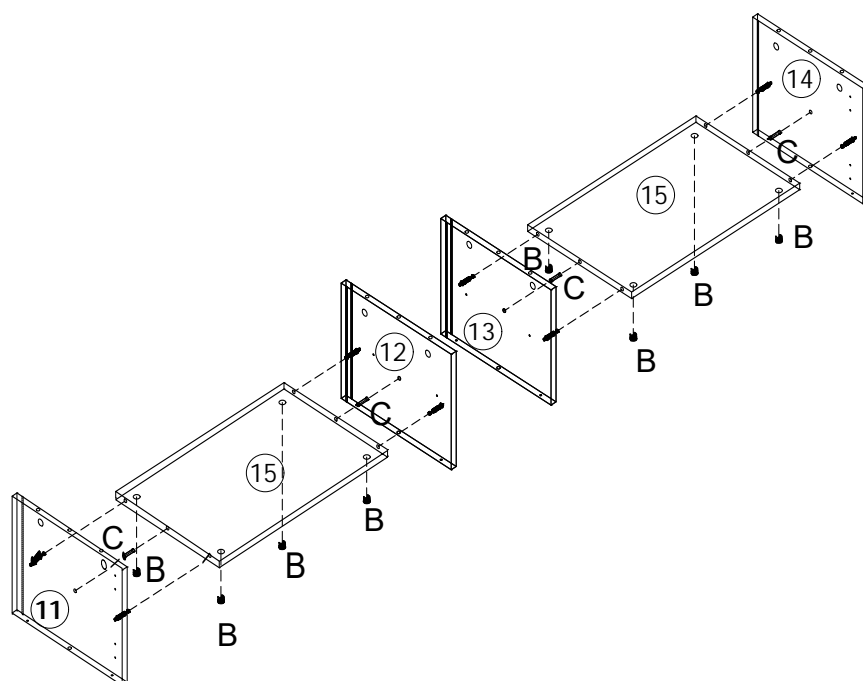

10



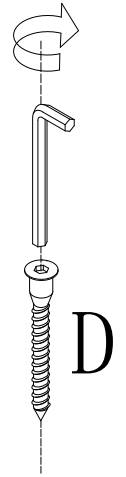
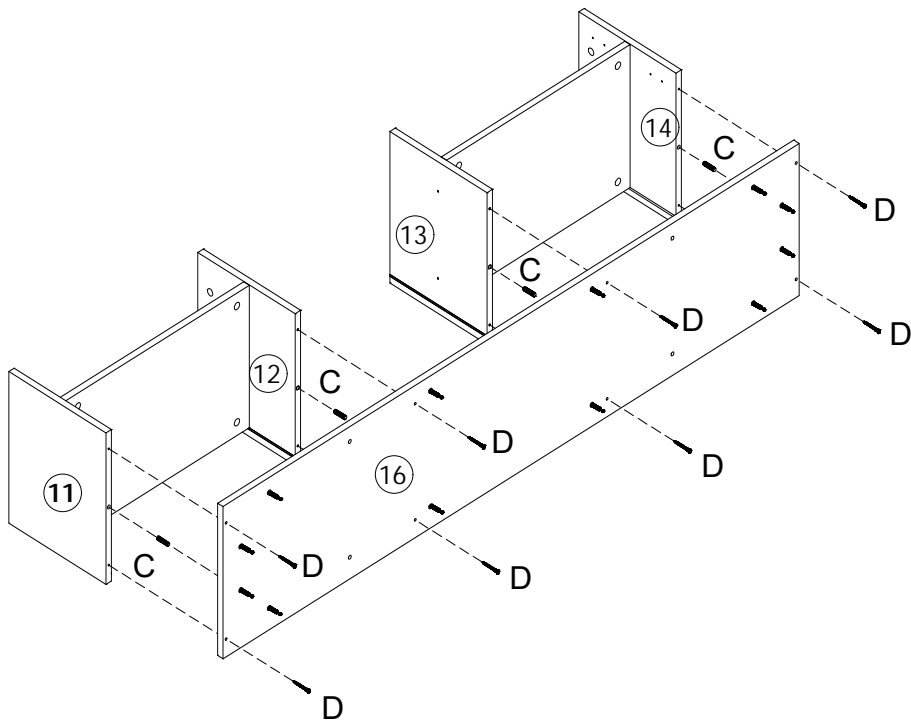

11

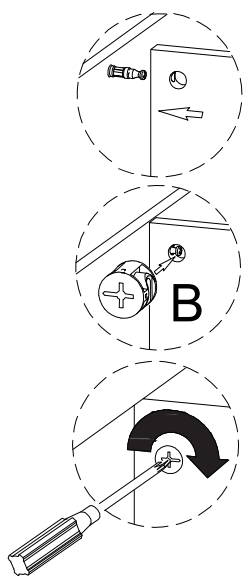
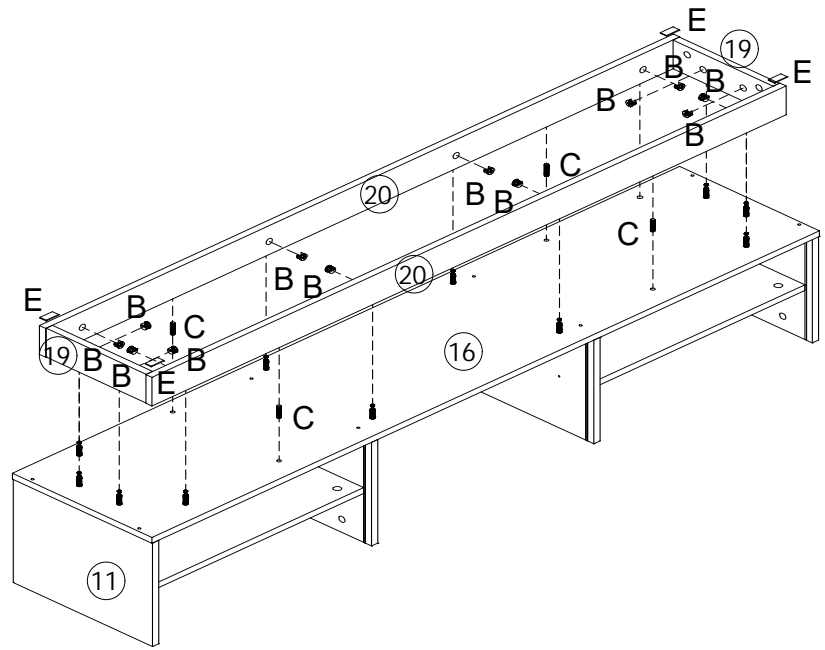

<p>C</p>  <p>4 PCS</p>	<p>D</p>  <p>8 PCS</p>
---	---

12



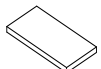

<p>B</p>  <p>12 PCS</p>	<p>C</p>  <p>4 PCS</p>	<p>E</p>  <p>4 PCS</p>
--	---	---

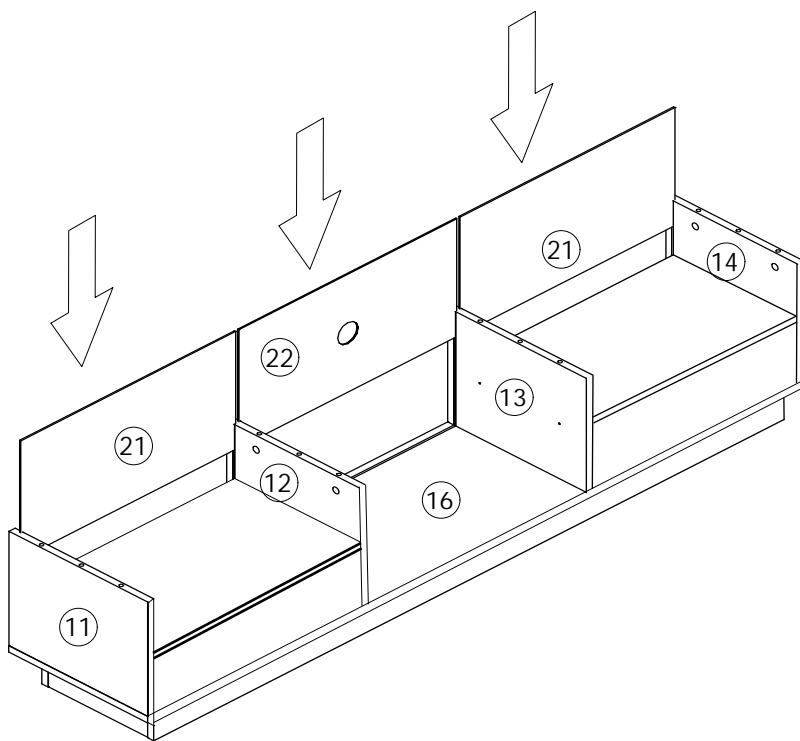
13

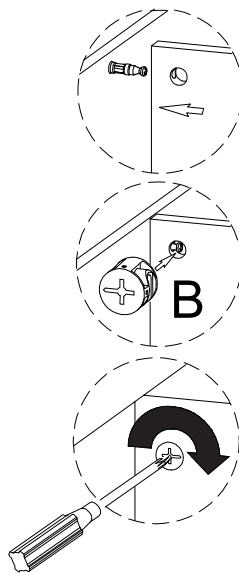
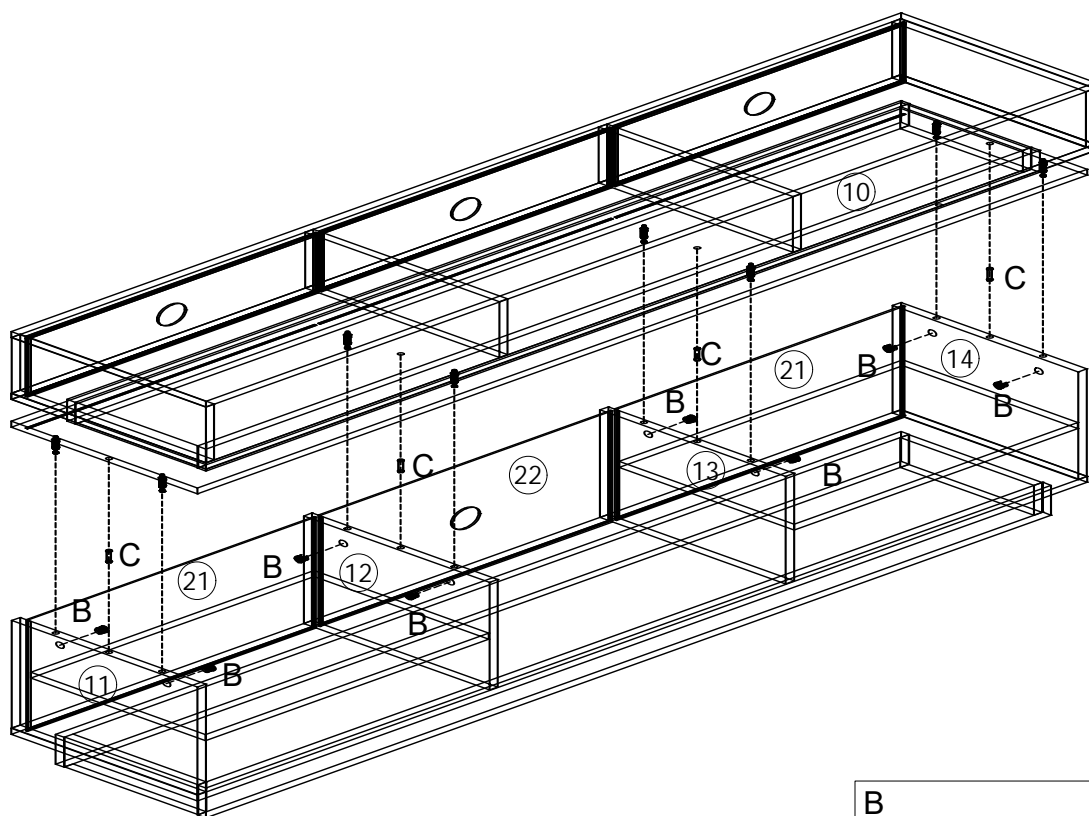

14



<p><b>B</b></p>  <p>8 PCS</p>	<p><b>C</b></p>  <p>4 PCS</p>
--	--

15

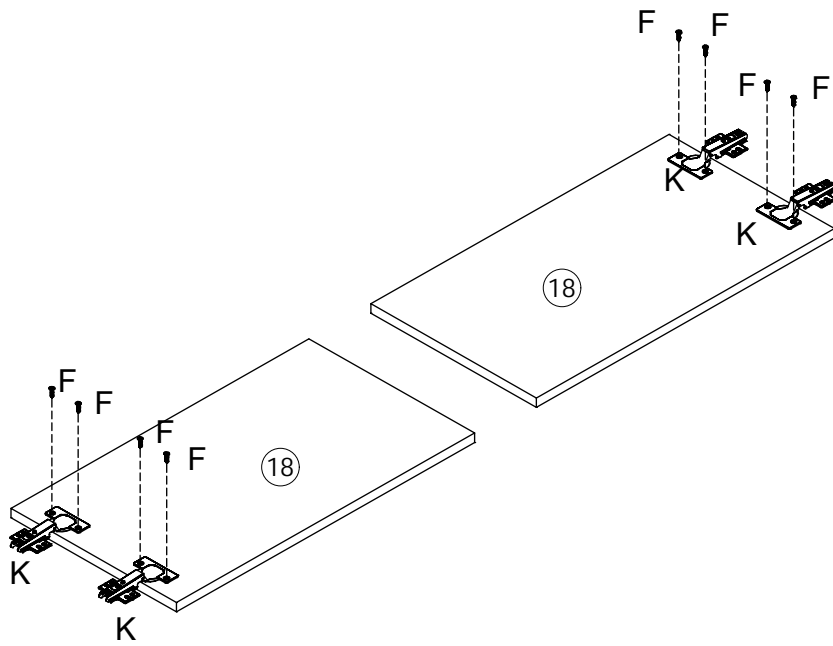

F		K	
	8 PCS		4 PCS

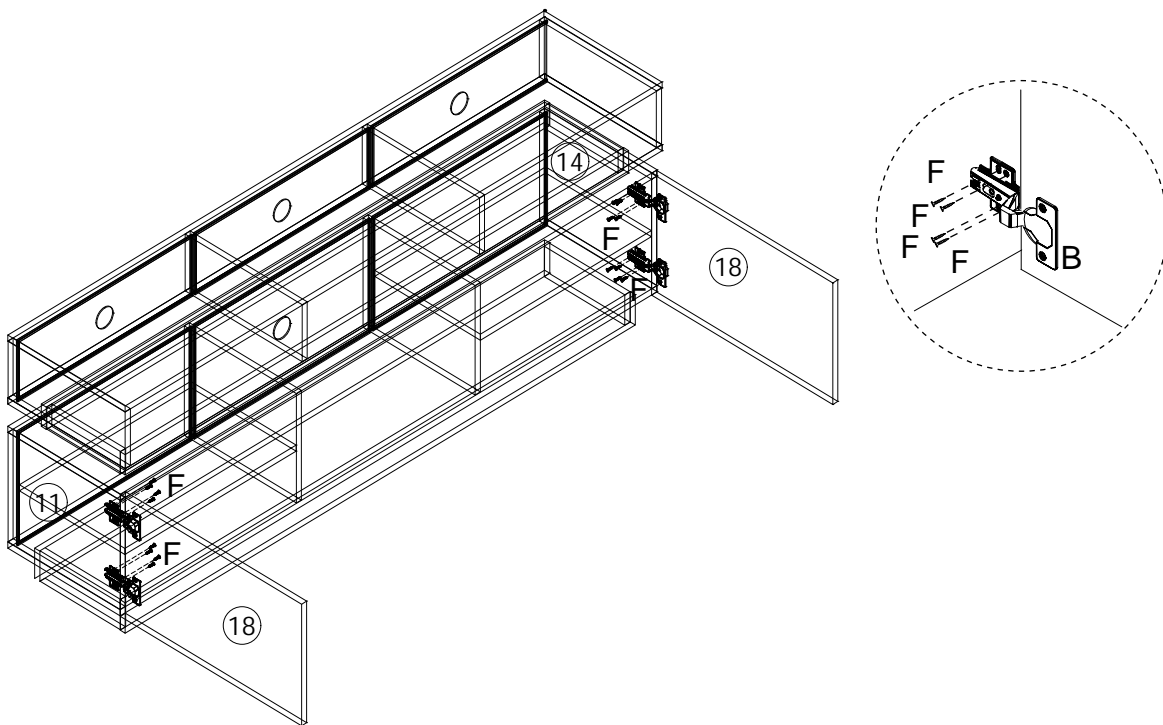

16

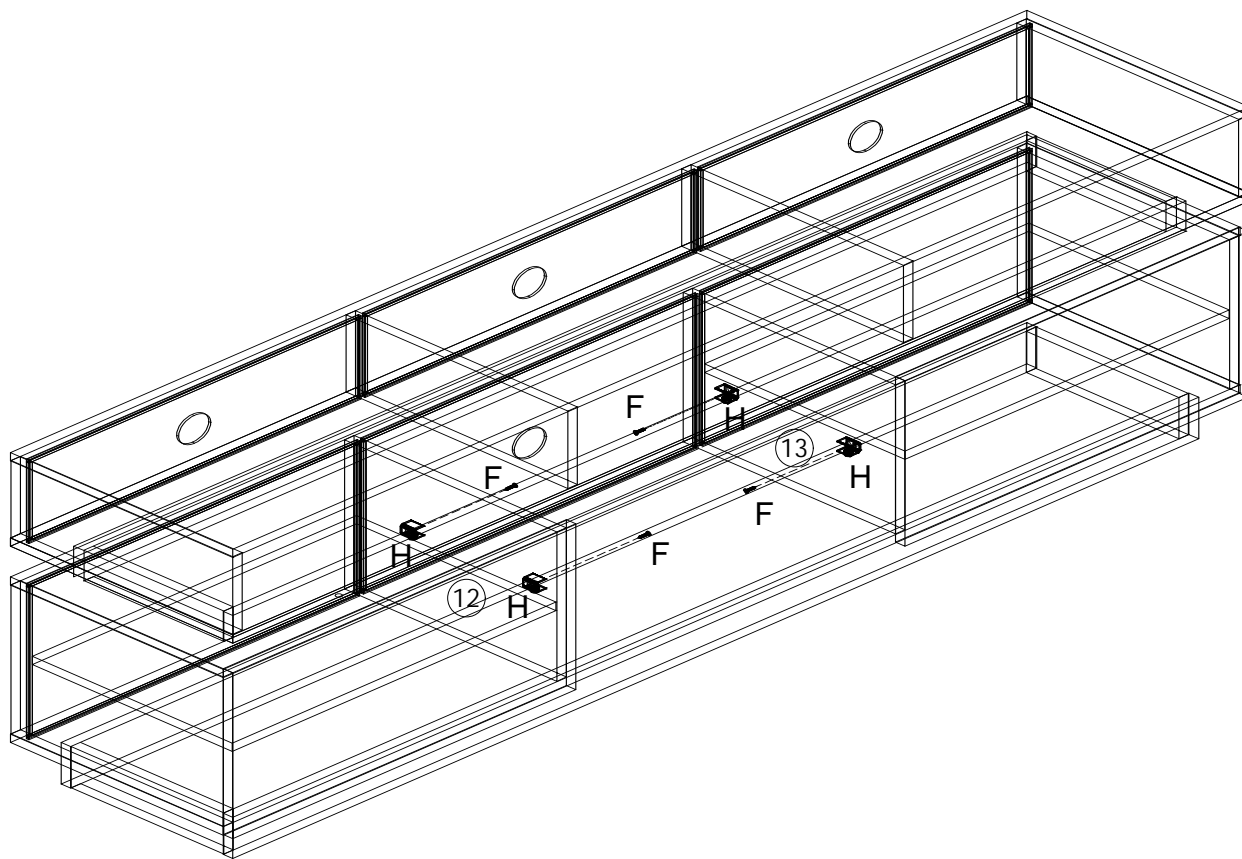

F	
	16 PCS

17



F		4 PCS	H		4 PCS
---	---	-------	---	---	-------

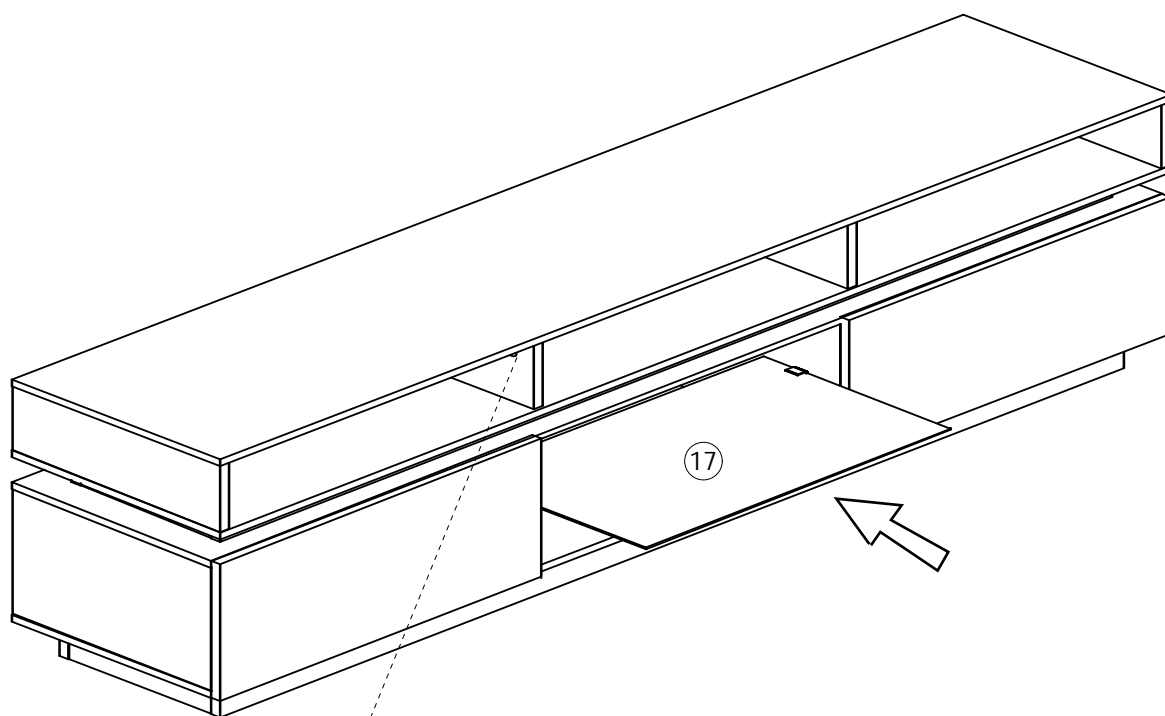

16



N		84PCS
---	---	-------

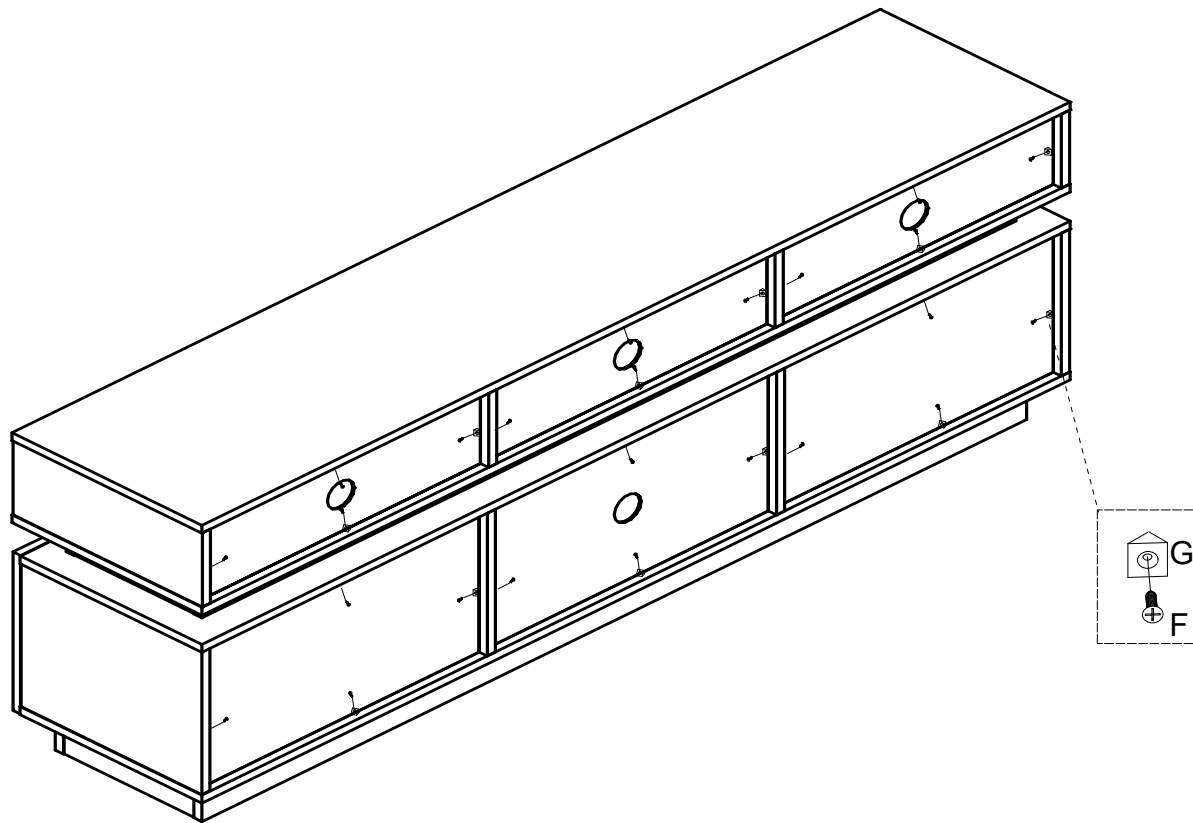



17

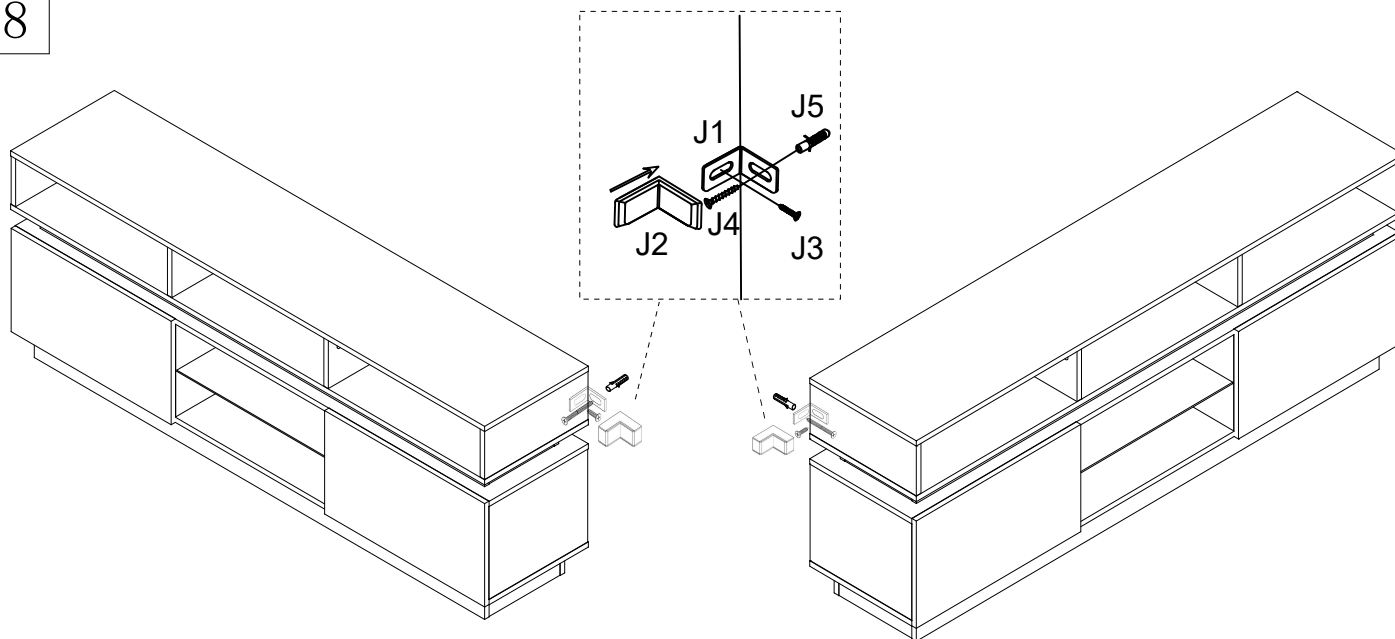

<p>F</p>  <p>24 PCS</p>	<p>G</p>  <p>24 PCS</p>
--	--

18



<p>J1</p>  <p>2 PCS</p>	<p>J2</p>  <p>2 PCS</p>	<p>J3</p>  <p>3.5*14</p> <p>2 PCS</p>	<p>J4</p>  <p>3.5*35</p> <p>2 PCS</p>	<p>J5</p>  <p>6*30</p> <p>2 PCS</p>
--	--	--	--	--



[DE]

BITTE BEACHTEN: Teilenummer 18.

ist mit einer dichten Kunststoffschutzfolie überzogen.

Wenn das Produkt nach der Demontage Kratzer aufweist, machen Sie sich bitte keine Sorgen, es handelt sich nicht um einen Produktschaden.

Bitte ziehen Sie die schützende Kunststoffolie langsam entlang der Kante von der Oberfläche ab. Nach dem Abziehen wird das Produkt glatt und sauber.

[EN]

PLEASE NOTE: Part number 18. are covered with a tight plastic protective film.

If there are scratches on the product after disassembly, please don't worry, it's not product damage.

Please slowly tear off the protective plastic film on the surface along the edge. After peeling off, the product becomes smooth and clean.

[FR]

REMARQUE : les pièces numéro 18. sont recouvertes d'

un film protecteur en plastique étanche. Si le produit présente des rayures après le démontage, ne vous inquiétez pas, il ne s'agit pas d'un dommage au produit.

Retirez lentement le film protecteur en plastique sur la surface le long du bord. Une fois décollé, le produit devient lisse et propre.

[IT]

NOTA BENE: il numero di parte 18.

è coperto da una pellicola protettiva in plastica stretta.

Se ci sono graffi sul prodotto dopo lo smontaggio, non preoccuparti, non è un danno al prodotto.

Strappare lentamente la pellicola protettiva in plastica sulla superficie lungo il bordo. Dopo averla staccata, il prodotto diventa liscio e pulito.

[ES]

NOTA: La pieza número 18.

está cubierta con una película protectora de plástico.

Si hay rayones en el producto después de desmontarlo, no se preocupe, no se trata de daños en el producto. Retire lentamente la película protectora de plástico de la superficie a lo largo del borde.

Después de despegarla, el producto quedará liso y limpio.

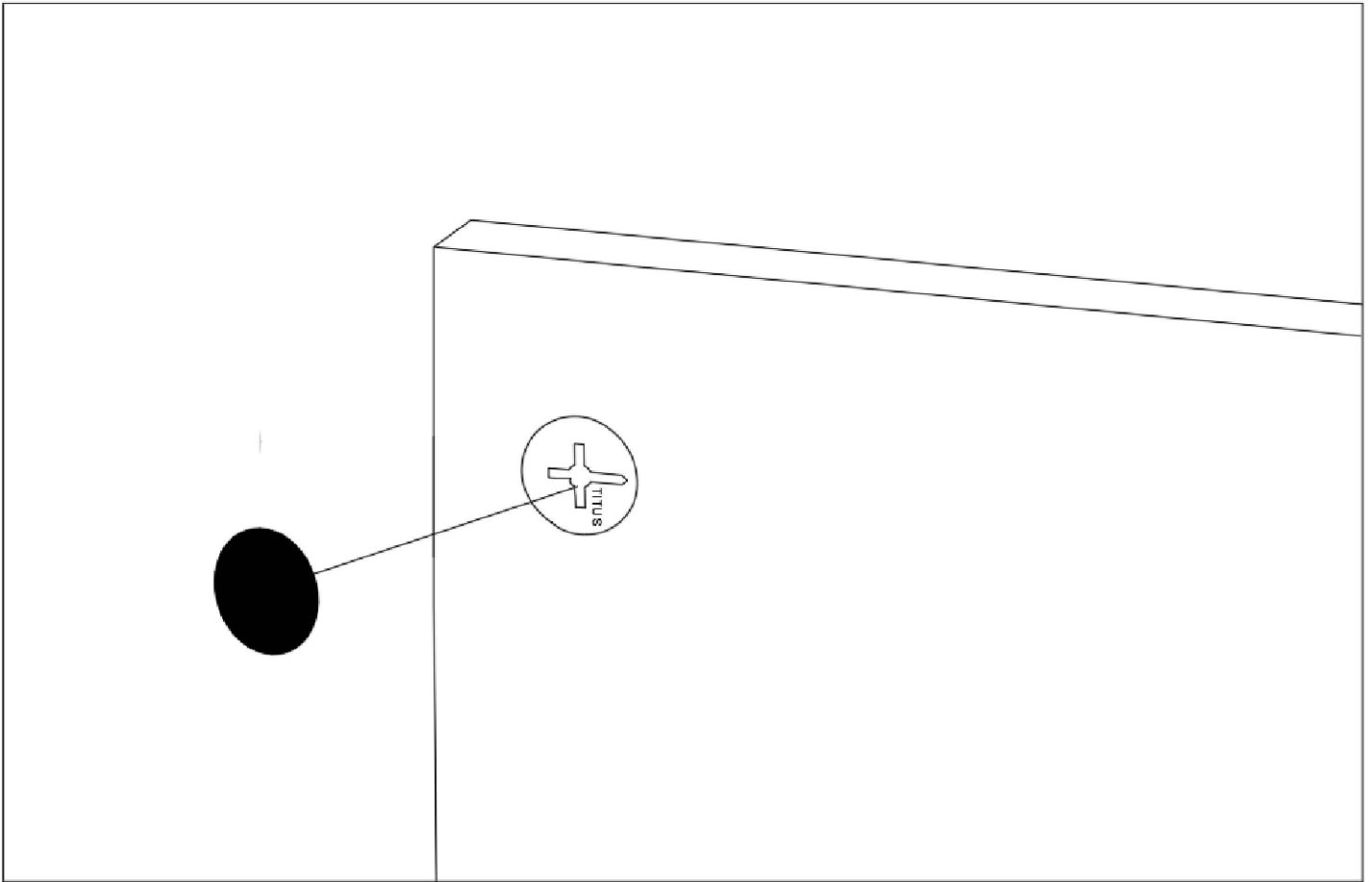

EN:In order to make the product more beautiful, please paste hardware N on the exposed holes.

DE:Um ein präzises produkt ästhetisieren zu können, fügen sie hardware N in eine entblöbte öffnung ein

FR:Afin de rendre le produit plus beau, s' il vous plaît coller le matériel N sur les trous exposés.

IT:Per rendere il prodotto più bello, incollare l' hardware N sui fori esposti.

ES:Con el fin de hacer el producto más hermoso, por favor pega hardware N en los agujeros expuestos



## APP-PROGRAMMANWENDUNG

Klicken, um  
Lampenliste  
anzuzeigen  
Farbrad  
wechseln

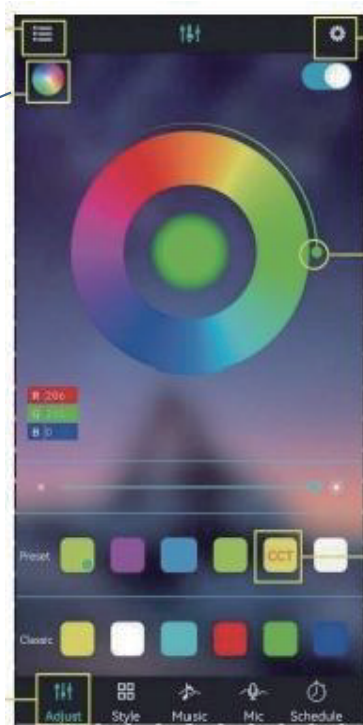

Klicken für  
Einstellungsansicht

Farbe anpassen

Farbanpassung  
per Quadrat-  
Symbol

Schnittstelle  
durch Klicken  
wechseln



HINWEIS:

Detaillierte Anleitung im  
Menü "Guide"

### PRODUKTPARAMETER

- Bluetooth: BLEVA 2
- Eingangsspannung: 4.5~26V
- Betriebstemperatur: -25~75 ° C
- Abmessungen: 43×22×11 mm
- Gewicht: 30g
- Max. Leistung: 144W (24V)

## VERBINDUNGSSCHRITTE

- ① LED-Farbstreifen & Controller verbinden, Controller einschalten
- ② QR-Code scannen zum App-Download:



- ③ App starten, Controller suchen & verbinden
- ④ Bluetooth-Drahtlossteuerung genießen

## PRODUKTMERKMALE

- Direkte Handy-Steuerung (20m Reichweite)
- Automatische Verbindung in 5 Sekunden
- Musikrhythmus-Synchronisation
- Gruppensteuerung
- Helligkeits-/Geschwindigkeitsregelung
- Unterstützt bis 10m RGB(W)-Streifen
- Automatische Sprachumschaltung (DE/EN)

## ANIMATIONSEFFEKTE

- Farbverläufe
- Einfarbige/ Zweifarbige Gradienten
- Monochrome/Bunte Blinkeffekte
- Farbspringen
- Musikresponsive Effekte

## APP PROGRAM USAGE

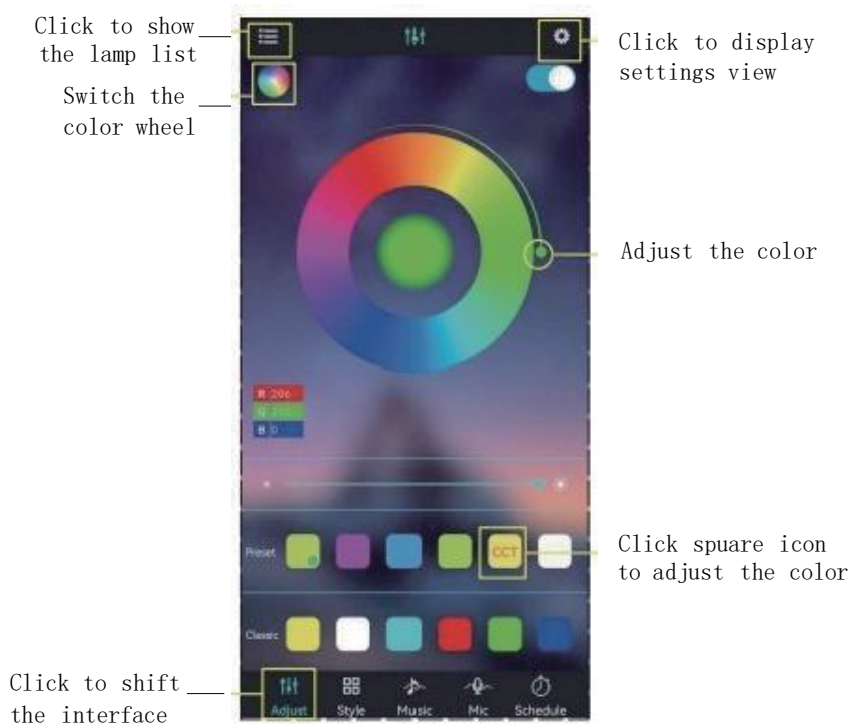

- Scan two-dimensional code download APP
- ①Connect LED color strip and controller, power on controller
  - ②Scan two-dimensional code download APP:



- ③Start APP, search and connect controller
- ④Enjoy the Bluetooth wireless control experience



Notes:  
detailed operating instructions,  
enter the menu "Guide":

Product Paramters:

- Bluetooth:BLEV4.2
- Input Voltage:4.5~26V
- Working Temp:-25~75°C
- Size:43\*22\*11mm
- Weight:30g
- Max Power:144W(24V)

LED mobile phone Bluetooth controllerProduct Features

- LED Bluetooth controller is directly via mobilephone control remote distance can reach 20m without the need to setupeasy to connect open the software within 5 seconds you can automatically connect the controller
- Flow the rhythm of the music changes
- Group control
- Brightness, speed addition and subtraction
- Maximum can be 10 meters RGB(W) strip
- The software shows that the text is based onthe language of the mobile phone set up automatic transformation of Chinese and English

ANIMATION EFFECTS:

- Colorful gradient
- All kinds of monochrome, double color gradient
- All kinds of monochrome, double color, colorfull flashing
- Colorful jump
- Follow the thymhm of the music chagnes

## APP-PROGRAMMANWENDUNG

Afficher la  
liste des lampes  
Farbrad  
Changer la  
Roue chromatique



Afficher les  
paramètres

Ajuster la couleur

Cliquez sur l'icône  
carrée pour ajuster  
la couleur.

Changer d'  
interface  
par clic



### REMARQUE :

Guide détaillé dans le menu  
"Guide"

### CARACTÉRISTIQUES

- Bluetooth : BLEVA 2
- Tension d'entrée : 4.5~26V
- Température : -25~75° C
- Dimensions : 43×22×11 mm
- Poids : 30g
- Puissance max : 144W (24V)

## ÉTAPES DE CONNEXION

- ① Connecter bande LED & contrôleur, allumer
- ② Scanner QR code pour télécharger l'app :



- ③ Lancer l'app, rechercher & connecter
- ④ Profiter du contrôle Bluetooth sans fil

## FONCTIONNALITÉS

- Contrôle direct par smartphone (20m)
- Connexion automatique en 5 secondes
- Synchronisation musicale
- Contrôle de groupe
- Réglage luminosité/vitesse
- Prise en charge bandes ≤10m RGB(W)
- Basculage automatique FR/EN

## EFFETS D'ANIMATION

- Dégradés de couleurs
- Dégradés uni/bicolores
- Clignotements mono/colorés
- Saut de couleurs
- Effets réactifs à la musique

## UTILIZZO APP



## PASSI CONNESSIONE

- ① Collega striscia LED & controller, accendi
- ② Scansiona QR code per scaricare APP:



- ③ Avvia APP, cerca & connetti controller
- ④ Goditi controllo wireless Bluetooth



## NOTA:

Guida completa nel menu "Guide"

## SPECIFICHE:

- Bluetooth: BLEVA 2
- Tensione ingresso: 4.5~26V
- Temperatura: -25~75° C
- Dimensioni: 43×22×11 mm
- Peso: 30g
- Potenza max: 144W (24V)

## CARATTERISTICHE

- Controllo diretto smartphone (20m)
- Connessione automatica in 5 secondi
- Sincronizzazione ritmo musicale
- Controllo di gruppo
- Regolazione luminosità/velocità
- Supporto strisce ≤10m RGB (W)
- Auto switch IT/EN

## EFFETTI ANIMAZIONE:

- Sfumature colore
- Gradienti mono/bicolori
- Luci lampeggianti mono/colorate
- Salto colori
- Effetti reattivi alla musica

## USO DE LA APLICACIÓN

Mostrar lista de —  
Lámparas  
Cambiar rueda de color

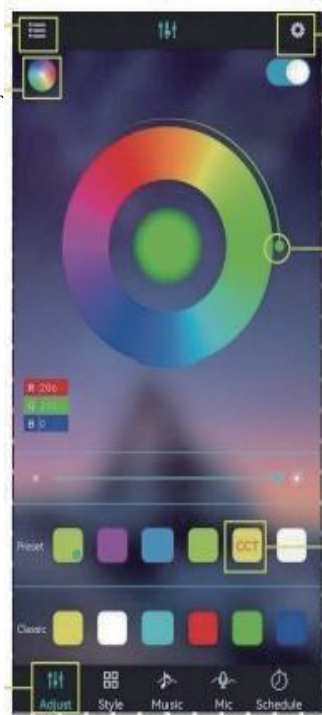

Ver ajustes

Ajustar el color

Clicar para ajustar color  
con icono cuadrado

Cambiar interfaz  
haciendo clic —



NOTA:

Guía completa en menú "Guide"

ESPECIFICACIONES:

- Bluetooth: BLEVA 2
- Voltaje entrada: 4.5~26V
- Temperatura: -25~75° C
- Tamaño: 43×22×11 mm
- Peso: 30g
- Potencia máx: 144W (24V)

## PASOS DE CONEXIÓN

- ① Conectar tira LED y controlador, encender
- ② Escanear QR para descargar APP:



- ③ Iniciar APP, buscar y conectar
- ④ Disfrutar control inalámbrico Bluetooth

## CARACTERÍSTICAS

- Control directo móvil (20m alcance)
- Conexión automática en 5 segundos
- Sincronización ritmo musical
- Control grupal
- Ajuste brillo/velocidad
- Soporte tiras ≤10m RGB(W)
- Auto cambio ES/EN

## EFFECTOS DE ANIMACIÓN:

- Degradados de color
- Transiciones mono/bicolores
- Destellos monocromáticos/color
- Salto de colores
- Efectos reactivos a música



TST Testing Technology

# Certificate Of Compliance

**Certificate No.** : TST202105Q2119-2EC  
**Applicant** : Shenzhen xu xing technology CO., LTD  
203, building a, Shangwu Power Industrial Park, Shiyan street, Bao'an District, Shenzhen City, Guangdong Province  
**Manufacturer** : Shenzhen xu xing technology CO., LTD  
203, building a, Shangwu Power Industrial Park, Shiyan street, Bao'an District, Shenzhen City, Guangdong Province  
**Product Name** : LED light band  
**Trade Mark** :   
**Main Test Model** : CLB2-2835-0  
**Additional Models** : CLB1-2835-1, CLB1-2835-2, CLB1-2835-3, CLB1-5050-R  
**Test Standard** : EN IEC 55015:2019+A11:2020  
EN 61547:2009  
EN IEC 61000-3-2:2019  
EN 61000-3-3:2013+A1:2019  
**As shown in the Test Report No.** : TST202105Q2119-2ER

The EUT described above has been tested by us with the listed standards and found in compliance with the council EMC directive 2014/30/EU. It is possible to use CE marking to demonstrate the compliance with this EMC Directive.

The certificate applies to the tested sample above mentioned only and shall not imply an assessment of the whole production. It is only valid in connection with the test report number. TST202105Q2119-2ER

Approved by: Andy Zheng

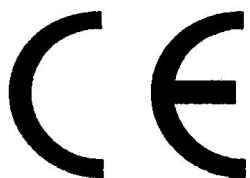

Manager

May. 12, 2021

**TST Testing Technology Co., Ltd**

2F Yinhe Building, Hetian Road, Houjie Town, Dongguan, Guangdong, China

Tel: 86-0769-85088050 Fax: 86-0769-85088450 E-mail: [tst@tst-test.com](mailto:tst@tst-test.com) <http://www.tst-test.com>



This certificate is responsible for testing sample only.  
Please refer to this corresponding test report to get testing process and data.

# CERTIFICATE

## ATTESTATION Certificate of Compliance

Technical file of the company mentioned below has been inspected and audit has been completed successfully

The RED Directive 2014/53/EU has been taken as references for these processes.

Certificate's Holder : Shenzhen xu xing technology co., LTD

Address : Floor 3, building C, Huaze hi tech Industrial Park, Shiyan street, Bao'an District, Shenzhen

Manufacturer : Shenzhen xu xing technology co., LTD

Address : Floor 3, building C, Huaze hi tech Industrial Park, Shiyan street, Bao'an District, Shenzhen

Product Name : XX LED RGB STRIP

Product Model (S) : XX5050RGB-60D, 5V-5050RGB-30D, 5V-5050RGB-60D, 12V-5050RGB-60D, 12V-5050RGB-30D, DY05RGB122, DY05RGB140, DY05RGB88

Trade Mark : N/A

Related Directive : 2014/53/EU

Article 3.1a) : EN IEC 62368-1:2024 + A11:2024  
EN 62479:2010  
EN 50663:2017

Related Standards : Article 3.1b) : ETSI EN 301 489-1 V2.2.3 (2019-11)  
ETSI EN 301 489-3 V2.3.2 (2023-01)  
EN IEC 61000-3-2:2019 + A1:2021 + A2:2024  
EN 61000-3-3:2013 + A1:2019 + A2:2021

Article 3.2) : ETSI EN 300 220-1 V3.1.1 (2017-02)  
ETSI EN 300 220-2 V3.3.1 (2025-03)

Certificate Number : HK2509024992E

Report No. : HK2509024992-1SR/-2EH/-1ER/-2ER

Registration Date : Oct. 21, 2025

*Jason Lau*  
Certification Manager



The information of the certificate can be checked through <https://www.huak.com>. The CE mark which is shown on the certificate can only be used under the conditions that the products complete with all of the relevant Directives of CE Declaration of Conformity. The Manufacturer should be responsible for the internal production control so that the products complied with the essential requirements of the above mentioned Directive(s). Certificate holder must notify all changes to the original certification laboratory of HUAKE.

Shenzhen HUAKE Testing Technology Co., Ltd.

Add:1-2/F, B2 Building, Junfeng Zhongcheng Zhizao Innovation Park, Heping Community, Fuhai Street, Bao'an District, Shenzhen, China  
Tel.:+86-0755-2302 9901 E-mail:info@huak.com Website:https://www.huak.com



This certificate is responsible for testing sample only.  
Please refer to this corresponding test report to get testing process and data.

# CERTIFICATE

## ATTESTATION Certificate of Compliance

Technical file of the company mentioned below has been inspected and audit  
has been completed successfully

The RoHS Directive 2015/863/EU amending Annex II to Directive 2011/65/EU has been taken as  
references for these processes.

Certificate's Holder : Shenzhen xu xing technology co., LTD  
Address : Floor 3, building C, Huaze hi tech Industrial Park, Shiyan street, Bao'an District,  
Shenzhen  
Manufacturer : Shenzhen xu xing technology co., LTD  
Address : Floor 3, building C, Huaze hi tech Industrial Park, Shiyan street, Bao'an District,  
Shenzhen  
Product Name: : XX LED RGB STRIP  
Model No.: : XX5050RGB-60D, 5V-5050RGB-30D, 5V-5050RGB-60D, 12V-5050RGB-60D,  
12V-5050RGB-30D, DY05RGB122, DY05RGB140, DY05RGB88  
Trade Mark : N/A  
Related Directive : Directive 2015/863/EU amending Annex II to Directive 2011/65/EU  
Directive (EU)2017/2102 amending Annex III to Directive 2011/65/EU  
IEC 62321-2:2021, IEC 62321-3-1:2013,  
Test Method : IEC 62321-5:2013, IEC 62321-4:2013+AMD1:2017, IEC 62321-7-1:2015,  
IEC 62321-7-2:2017, IEC 62321-6:2015, IEC 62321-8:2017  
Certificate Number : HK25090210619R  
Report No. : HK25090210619-1RR  
Issue date : October 20, 2025

Jason  
Certification Manager



The information of the certificate can be checked through [www.huak.com](http://www.huak.com). The CE mark  
which is shown on the certificate can only be used under the conditions that the products  
complete with all of the relevant Directives of EC Declaration of Conformity. The  
Manufacturer should be responsible for the internal production control so that the  
products complied with the essential requirements of the above mentioned Directive(s).  
Certificate holder must notify all changes to the original certification laboratory of HUAKE.

# RoHS

Shenzhen HUAKE Testing Technology Co., Ltd.

Add.:1-2/F, B2 Building, Junfeng Zhongcheng Zhizao Innovation Park, Heping Community, Fuhai Street, Bao'an District, Shenzhen, China

Tel.:+86-0755-2302 9901

E-mail:info@huak.com

Website:https://www.huak.com