

N635P416474

N635P416475

Product manual
Gebrauchsanweisung
Manuel du produit
Manual del producto
Manuale del prodotto

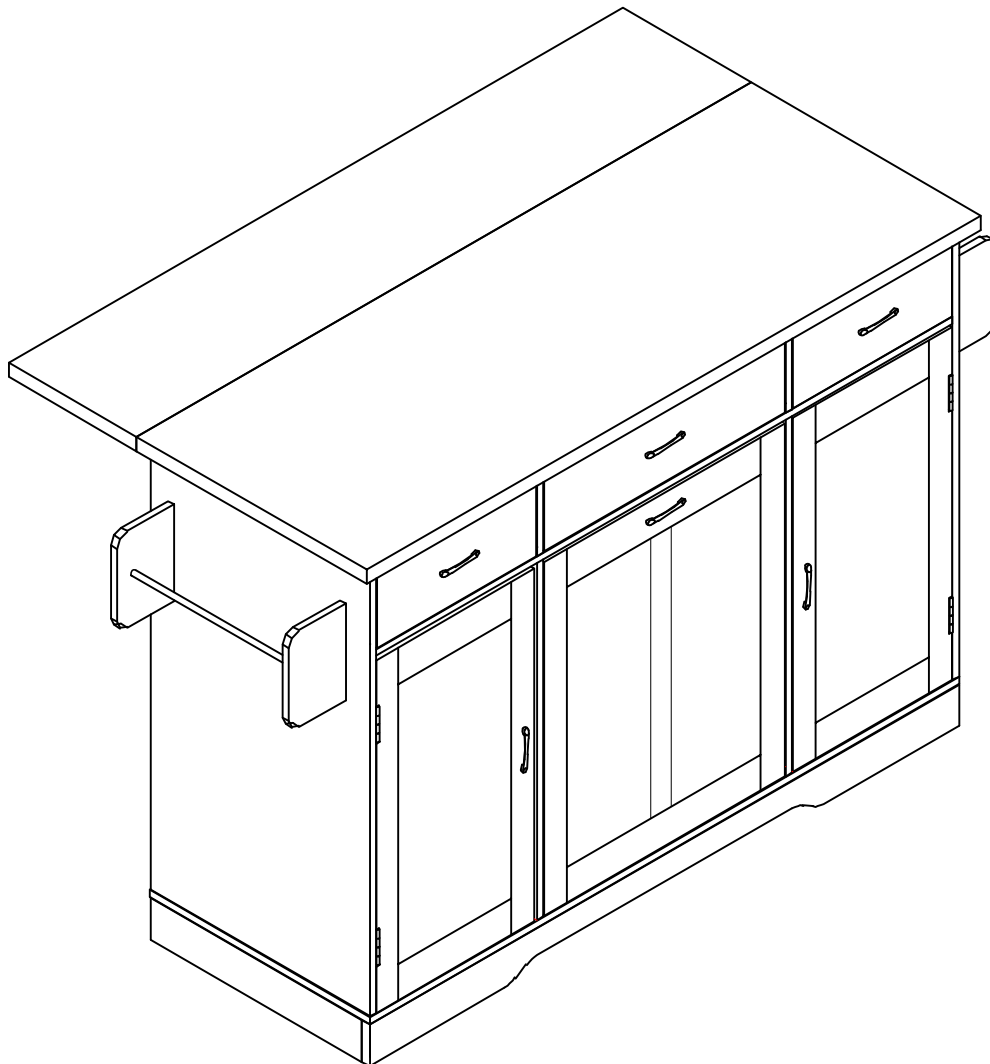

FR

Pensez à donner ou recycler.



ou



ou



<https://quefairedemesdechets.fr>



FR

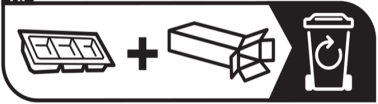

EN:Our product will be delivered to you in 2 packages. The delivery times of these 2 packages may differ, please be patient and thank you for your understanding

FR:Notre produit vous sera livré en 2 colis. Les délais de livraison de ces 2 colis peuvent différer, soyez patient et merci de votre compréhension.

DE:Unser Produkt wird Ihnen in 2 Paketen geliefert. Die Lieferzeiten dieser 2 Pakete können abweichen, bitte haben Sie etwas Geduld und vielen Dank für Ihr Verständnis

IT:I nostri prodotti vengono trasportati in due pacchetti. I tempi di consegna dei due pacchetti sono diversi: abbiate pazienza e vi ringrazio per la vostra comprensione.

ES:Nuestro producto se entrega en dos paquetes. El tiempo de entrega de estos dos paquetes es diferente. Por favor, sea paciente. Gracias por su comprensión.

Importeur	Decobus Handel GmbH
Adresse	Innungsstraße 9, 21244 Buchholz Deutschland
URL	https://www.decobusgroup.de
Hersteller	YESHENG FURNITURE CO., LTD
Adresse	Leshang Center Complex Building, Shouguang City, Weifang City, Shandong Province, China
Email/URL	www.yeshengfurniture.com
EC REP	Decobus Handel GmbH Innungsstraße 9, 21244 Buchholz Deutschland https://www.decobusgroup.de



2PERS

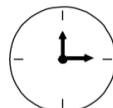

45 MIN

Tool Required Not Provided

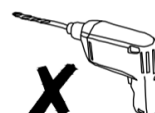
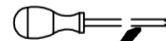
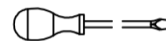

Hergestellt in China



[DE]

Warnung: Lesen Sie die Anleitung vor dem Zusammenbau bitte vollständig durch. Überprüfen Sie, ob Sie alle auf den Seiten aufgeführten Komponenten und Werkzeuge haben.

Warnung: Legen Sie alle Teile auf eine ebene Fläche. Legen Sie eine weiche Decke oder Ähnliches darunter, um sie vor Kratzern oder Flecken zu schützen. Vermeiden Sie es, Komponenten über den Boden zu ziehen oder zu schieben.

Warnung: Überprüfen Sie regelmäßig alle Beschläge und Befestigungen, um sicherzustellen, dass sie sicher sind und um Unfälle zu vermeiden. Wenn Teile fehlen, kaputt, beschädigt oder abgenutzt sind, verwenden Sie das Produkt nicht weiter, bis es mit vom Hersteller autorisierten Teilen repariert wurde.

Warnung: Lassen Sie Kinder nicht auf die Möbel klettern, da dies zum Umkippen und zu schweren Verletzungen führen kann. Bauen Sie die Möbel außerhalb der Reichweite von Kindern zusammen.

Warnung: Stellen Sie die Möbel nicht in die Nähe von Feuerquellen oder heißen Gegenständen, um Brandgefahr zu vermeiden.

Warnung: Reinigen Sie die Möbel mit einem feuchten Tuch oder Alkohol. Verwenden Sie keine Reinigungsmittel mit ätzenden Chemikalien.

[EN]

Warning: Please read instructions fully before starting assembly. Check you have all the components and tools listed on pages.

Warning: Please place all parts on a flat surface. Place a soft blanket or similar underneath to protect against scratches or stains. Avoid dragging or sliding components across the floor.

Warning: Regularly check all fittings and fastenings to ensure they are secure and to prevent accidents. If any parts are missing, broken, damaged, or worn, discontinue use of the product until repairs have been made using factory authorized parts.

Warning: Do not allow children to climb on the furniture as this may result in tipping and serious personal injury. Assemble the furniture away from the reach of children.

Warning: Do not place furniture close to fire sources or high-temperature objects to avoid the risk of fire.

Warning: Clean furniture with a damp cloth or alcohol, avoid using cleaning agents containing corrosive chemicals.

[FR]

Avertissement : Veuillez lire entièrement les instructions avant de commencer l'assemblage. Vérifiez que vous disposez de tous les composants et outils répertoriés sur les pages.

Avertissement : Veuillez placer toutes les pièces sur une surface plane. Placez une couverture douce ou similaire en dessous pour les protéger des rayures ou des taches. Évitez de faire glisser les composants sur le sol.

Avertissement : Vérifiez régulièrement tous les raccords et fixations pour vous assurer qu'ils sont bien fixés et pour éviter les accidents. Si des pièces manquent, sont cassées, endommagées ou usées, cessez d'utiliser le produit jusqu'à ce que des réparations aient été effectuées à l'aide de pièces autorisées par l'usine.

Avertissement : Ne laissez pas les enfants grimper sur les meubles car cela pourrait entraîner un basculement et des blessures graves. Assemblez les meubles hors de portée des enfants.

Avertissement : Ne placez pas les meubles à proximité de sources de feu ou d'objets à haute température pour éviter tout risque d'incendie.

Avertissement : Nettoyez les meubles avec un chiffon humide ou de l'alcool, évitez d'utiliser des produits de nettoyage contenant des produits chimiques corrosifs.



[IT]

Attenzione: leggere attentamente le istruzioni prima di iniziare il montaggio. Verificare di avere tutti i componenti e gli strumenti elencati nelle pagine.

Attenzione: posizionare tutte le parti su una superficie piana. Posizionare una coperta morbida o simile sotto per proteggere da graffi o macchie. Evitare di trascinare o far scivolare i componenti sul pavimento.

Attenzione: controllare regolarmente tutti i raccordi e i dispositivi di fissaggio per assicurarsi che siano sicuri e per prevenire incidenti. Se alcune parti sono mancanti, rotte, danneggiate o usurate, interrompere l'uso del prodotto fino a quando non siano state eseguite le riparazioni utilizzando parti autorizzate dalla fabbrica.

Attenzione: non consentire ai bambini di arrampicarsi sui mobili poiché ciò potrebbe causare ribaltamenti e gravi lesioni personali. Montare i mobili lontano dalla portata dei bambini.

Attenzione: non posizionare i mobili vicino a fonti di fuoco o oggetti ad alta temperatura per evitare il rischio di incendio.

Attenzione: pulire i mobili con un panno umido o alcol, evitare di utilizzare detergenti contenenti sostanze chimiche corrosive.

[ES]

Advertencia: Lea las instrucciones completamente antes de comenzar el montaje. Compruebe que tiene todos los componentes y herramientas que se enumeran en las páginas.

Advertencia: Coloque todas las piezas sobre una superficie plana. Coloque una manta suave o algo similar debajo para protegerlas de rayones o manchas. Evite arrastrar o deslizar los componentes por el piso.

Advertencia: Verifique regularmente todos los accesorios y fijaciones para asegurarse de que estén seguros y evitar accidentes. Si falta alguna pieza, está rota, dañada o desgastada, deje de usar el producto hasta que se hayan realizado las reparaciones con piezas autorizadas de fábrica.

Advertencia: No permita que los niños se suban a los muebles, ya que esto puede provocar que se vuelquen y lesiones personales graves. Monte los muebles fuera del alcance de los niños.

Advertencia: No coloque los muebles cerca de fuentes de fuego u objetos de alta temperatura para evitar el riesgo de incendio.

Advertencia: Limpie los muebles con un paño húmedo o alcohol, evite usar agentes de limpieza que contengan químicos corrosivos.

Importeur	Decobus Handel GmbH		
Adresse	Innungsstraße 9,21244 Buchholz Deutschland		
URL	https://www.decobusgroup.de		
Hersteller	YESHENG FURNITURE CO., LTD		
Adresse	Leshang Center Complex Building, Shouguang City, Weifang City, Shandong Province, China		
Email/URL	www.yeshengfurniture.com		
<table border="1"><tr><td>EC</td><td>REP</td></tr></table>	EC	REP	Decobus Handel GmbH Innungsstraße 9,21244 Buchholz Deutschland https://www.decobusgroup.de
EC	REP		

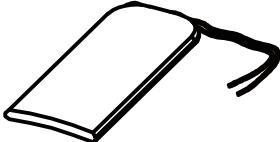
BOX 1-2 SKU:N635P416476		BOX 2-2 SKU:N635P416477	
1	1200*450*24*=1PC	3	754*430*12*=1PC
2	1200*250*24*=1PC	4	754*430*12*=1PC
7	1152*430*12*=1PC	5	601.5*405*12*=1PC
8	314*289*12*=2PCS	6	601.5*405*12*=1PC
9	1126*100*12*=1PC	11	140.5*404*12*=1PC
10	1126*100*12*=1PC	12	140.5*429*12*=1PC
13	1152*70*15*=1PC	14	413*70*15*=1PC
17	130*130*15*=1PC	15	413*70*15*=1PC
18	441.5*100*12*=2PCS	16	413*70*15*=2PCS
19	441.5*100*12*=2PCS	21	310*135*15*=2PCS
20	220*99*12*=6PCS	25	274*297*3*=2PCS
22	300*80*12*=3PCS	26	470*135*15*=1PC
23	300*80*12*=3PCS	28	434*297*3*=1PC
24	264*80*12*=2PCS	29	597.5*470*15*=1PCS
27	424*80*12*=1PC	30	338*250*12*=1PC
32	468*225*12*=1PC	31	338*250*12*=1PC
33	444*338*12*=1PC	34	608.5*377*3*=3PCS
35	807*147.5*3*=1PC	36	321*147.5*3*=1PC
		37	138.5*180*15*=3PCS
		38	163*110*12*=2PCS
		39	163*110*12*=2PCS
		40	597.5*310*15*=1PC
		41	597.5*310*15*=1PC
			

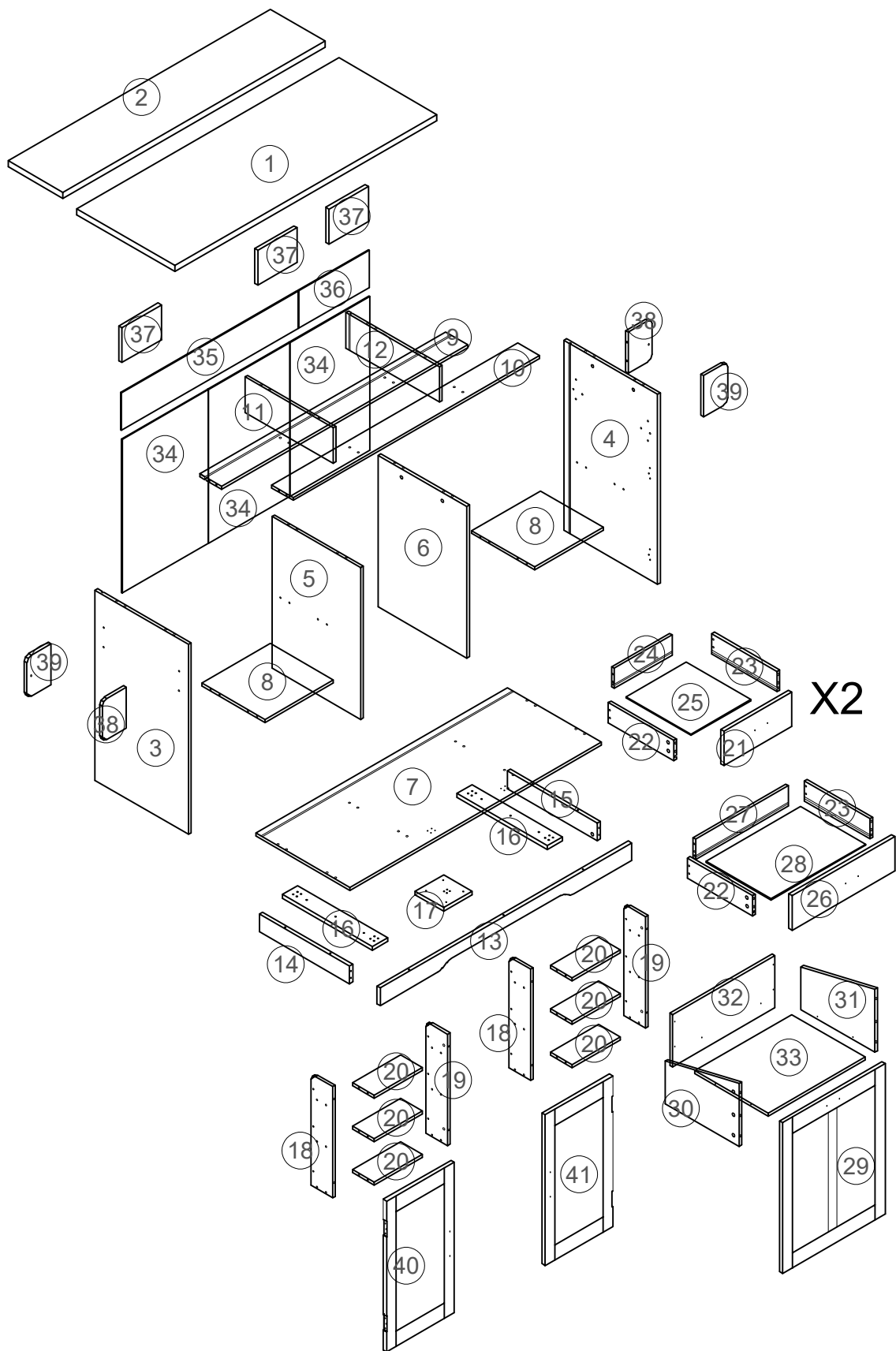

A x66
+2(spare)

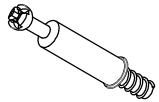

B x66
+2(spare)



C x35
M6*30
+2(spare)

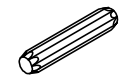

D x16
M5*40
+1(spare)



E x3
300mm

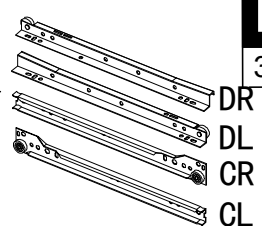

F x 2

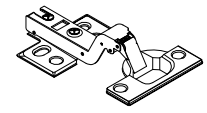

G x 6
M4*18

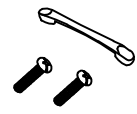

H x 2

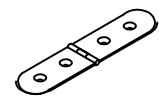

I x 4

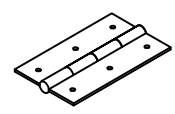

J x 8

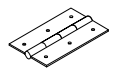

K x 3



L x 2

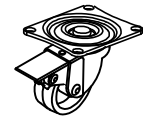

M x140
M3.5*12
+2(spare)



N x10
M3.5*25
+1(spare)

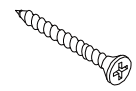

O x36
M3.5*35
+1(spare)

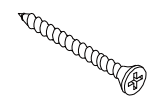

P x2
601mm



Q x10

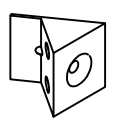

R x2
343mm

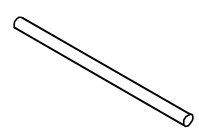

S x6
230mm

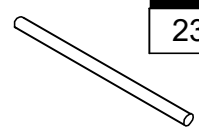

T x26

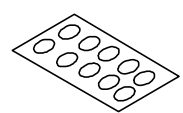

U x18
M3*14
+1(spare)



V x2

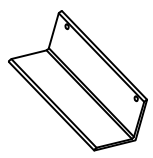

W x2

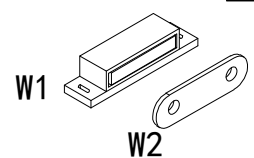

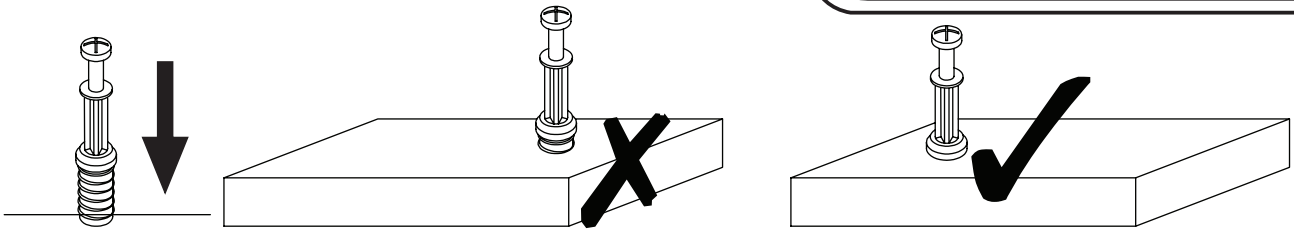

EN_QUICKFIT: Tighten quickfit until shoulder is flush with panel. Do not overtighten or undertighten.

FR_RACCORD RAPIDE: Faites serrer le raccord rapide jusqu'à ce que l'épaulement soit parfaitement encastré dans le panneau. Il ne faut ni trop serrer ni insuffisamment serrer.

ES_QUICKFIT: Apriete quickfit hasta que el hombro se descargue con el panel. NO lo sobreapriete ni lo apriete poco.

DE_QUICKFIT: Ziehen Sie den Quickfit fest, bis die Schulter mit der Platte bündig ist. Bitte nicht zu fest oder zu schwach anziehen.

IT_MONTAGGIO RAPIDO: Stringere il montaggio rapido fino a quando la spalla è a filo con il pannello, non stringere troppo o troppo poco.

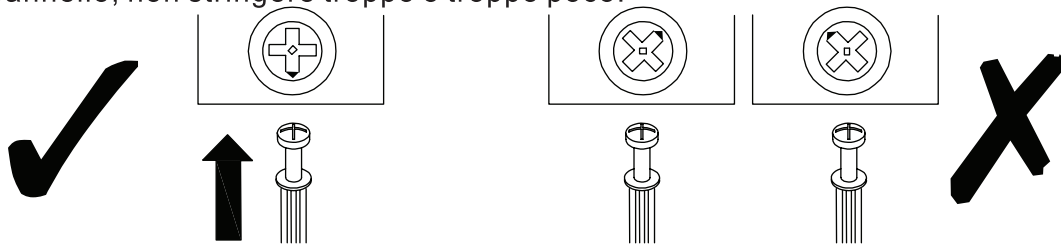

EN_CAM LOCK: When fitting cam lock, ensure starting position is correct before you insert connecting quickfit.

FR_SERRURE BATTEUSE: Avant d'insérer la serrure batteuse, veillez à la bonne orientation avant d'insérer le raccord rapide.

ES_CIERRE DE LA CÁMARA: Cuando instale el cierre de la cámara, asegúrese de que la posición de inicio es correcta antes de que inserte el quickfit conector.

DE_CAM-LOCK: Achten Sie bei der Montage des Cam-Locks auf die richtige Ausgangsposition, bevor Sie den Quickfit einsetzen.

IT_BLOCCAGGIO A CAMMA: Quando si monta il bloccaggio a camma, assicurarsi che la posizione iniziale sia corretta prima di inserire il montaggio rapido di collegamento.

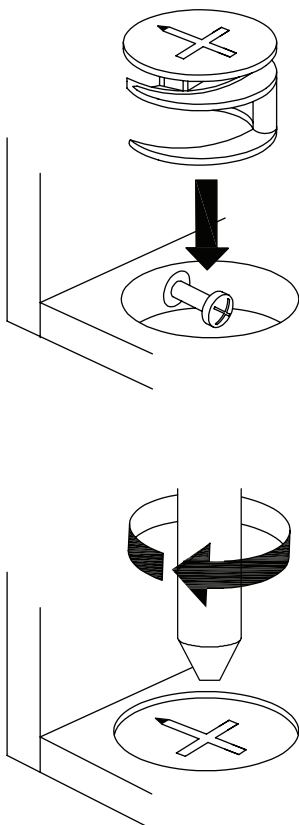

EN_Quickfit head should be in the centre of the cam lock when the two panels are joined.

Cam lock should be inserted before quickfit.

FR_Lorsque les deux panneaux sont assemblés, la tête du raccord rapide doit reposer au centre de la serrure batteuse. Il faut insérer la serrure batteuse avant le raccord rapide.

ES_El cabezal del quickfit debe estar en el centro del cierre de la cámara cuando se unan los dos paneles.

Se debe insertar el cierre de la cámara antes que el quickfit.

DE_Der Quickfit-Kopf sollte sich in der Mitte des Cam-Locks befinden, wenn die beiden Platten zusammengefügt sind. Der Cam-Lock sollte vor dem Quickfit eingesetzt werden.

IT_La testa del montaggio rapido deve trovarsi al centro del bloccaggio a camma quando i due pannelli sono uniti.

Il Bloccaggio a Camma deve essere inserito prima del montaggio rapido.

EN_Turn cam lock clockwise to tighten.

FR_Faites tourner la serrure batteuse dans le sens des aiguilles d'une montre pour la resserrer.

ES_Gire el cierre de la cámara en sentido horario para apretarlo.

DE_Drehen Sie den Cam-Lock im Uhrzeigersinn, um ihn festzuziehen.

IT_Ruotare il bloccaggio a camma in senso orario per stringere.

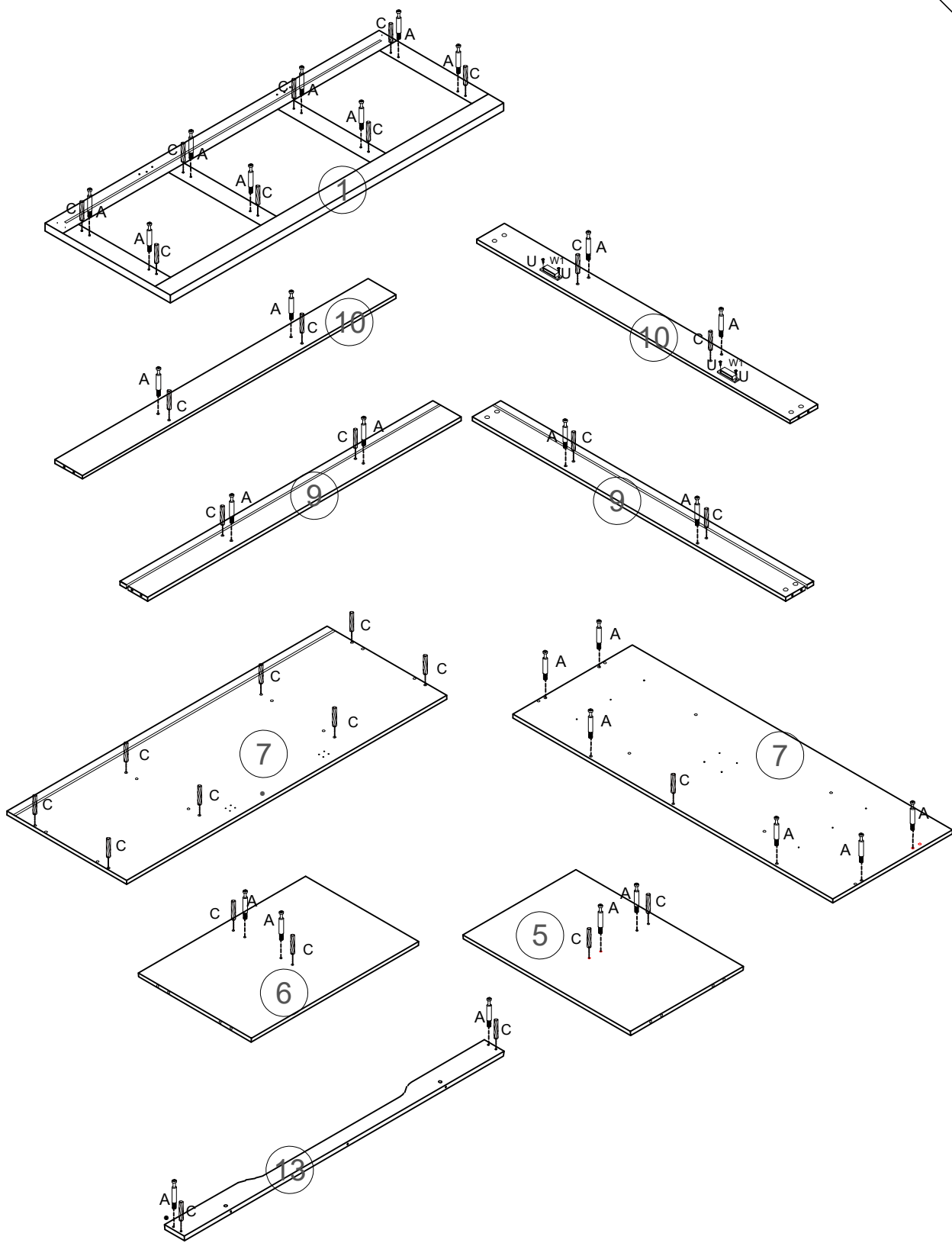

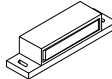
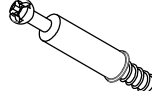
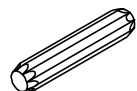
 U x4 M3*14	 W x2	 A x28	 C x31 M6*30
---	--	---	--

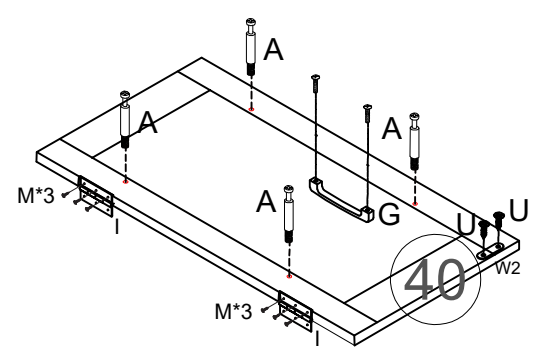
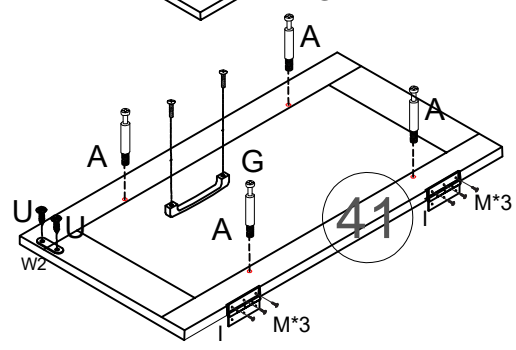
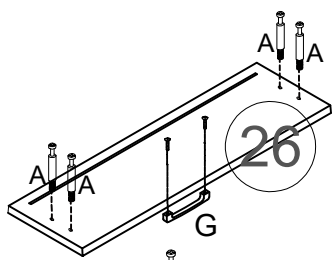
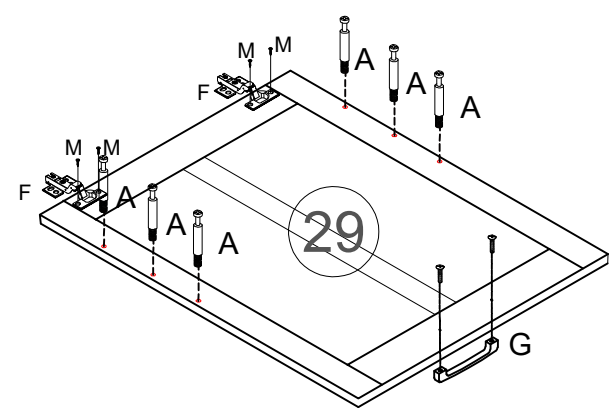
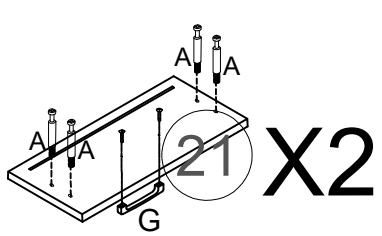
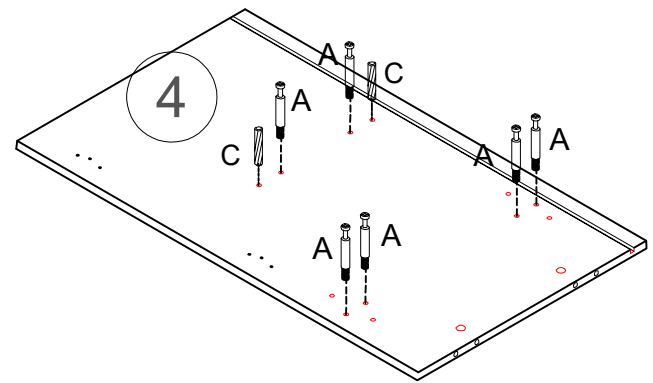
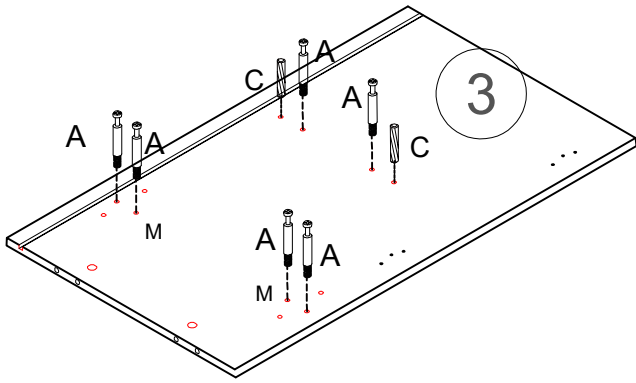

<p>W x2</p>	<p>G x6</p>	<p>F x2</p>
<p>U x4 M3*14</p>	<p>A x38</p>	<p>C x4 M6*30</p>

<p>I x4</p>	<p>M x16 M3.5*12</p>
--------------------	---------------------------------

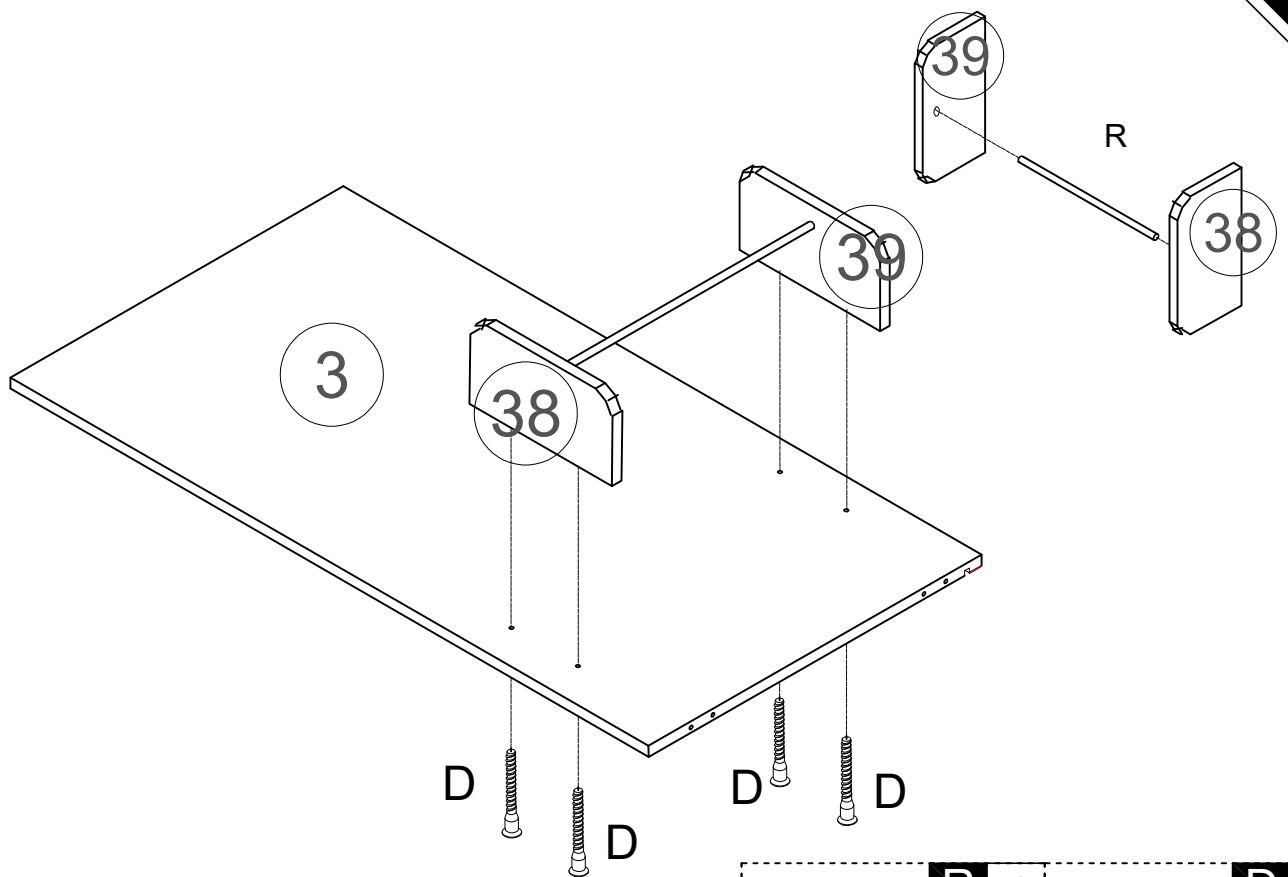

R x1 343mm	D x4 M5*40
----------------------	----------------------

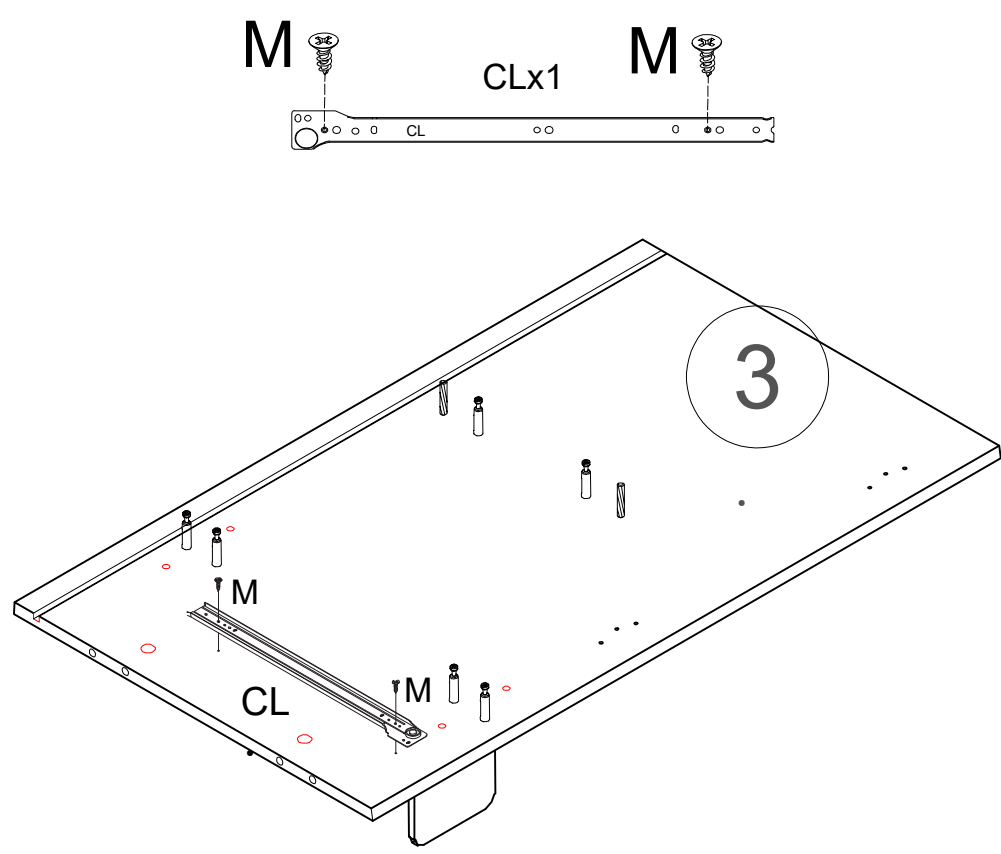

M x2 M3.5*12	E x1 300mm
------------------------	----------------------

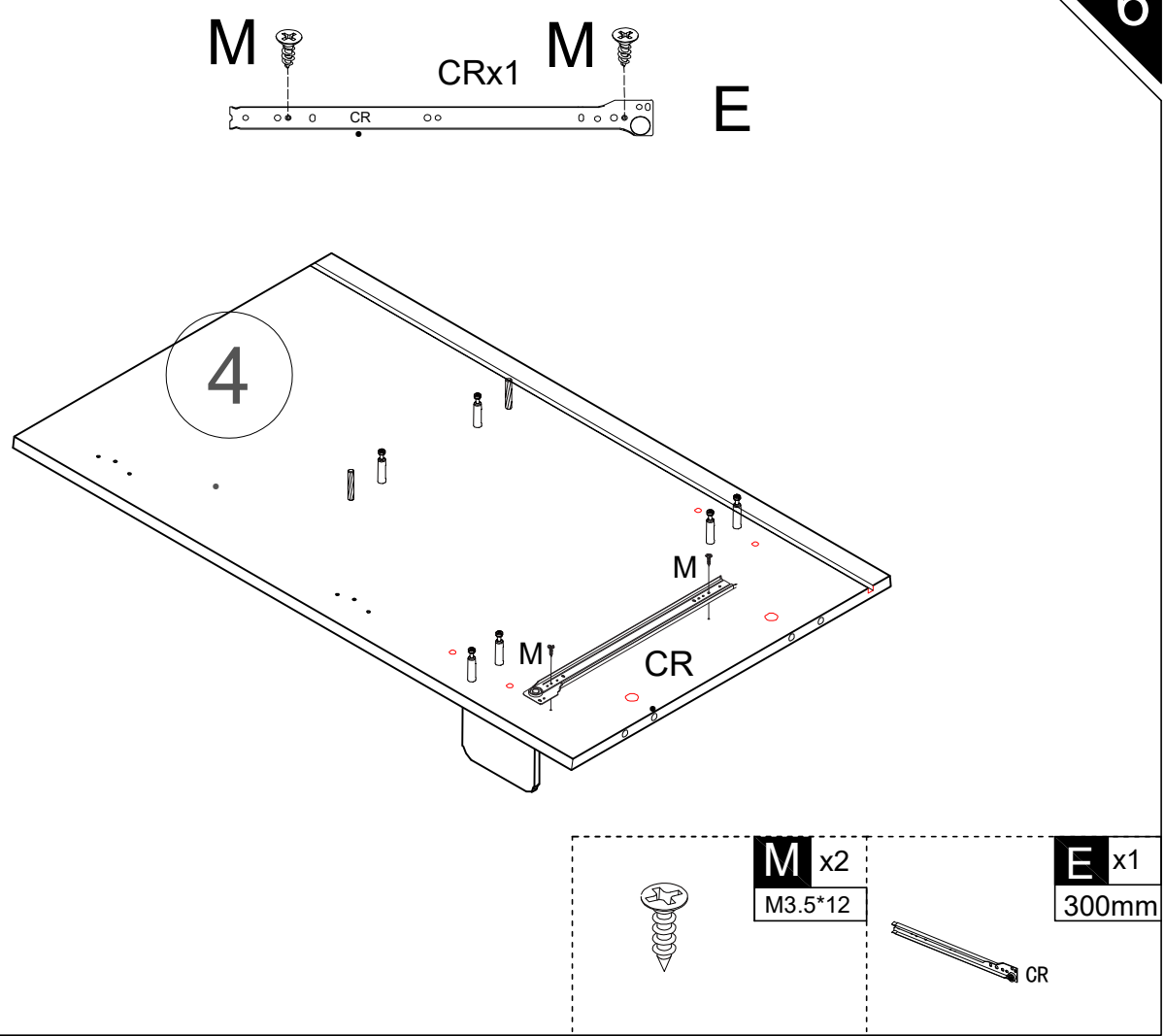
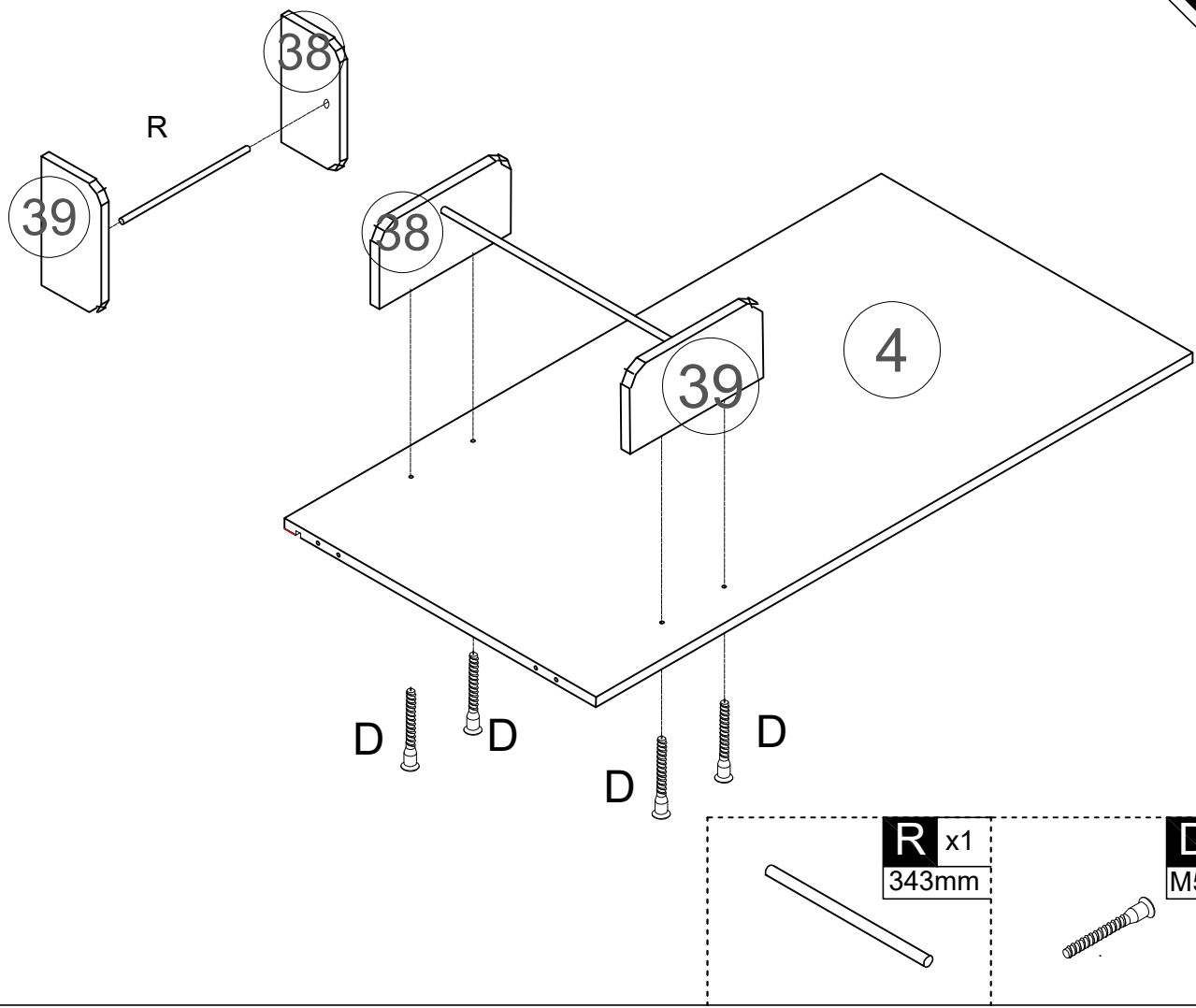

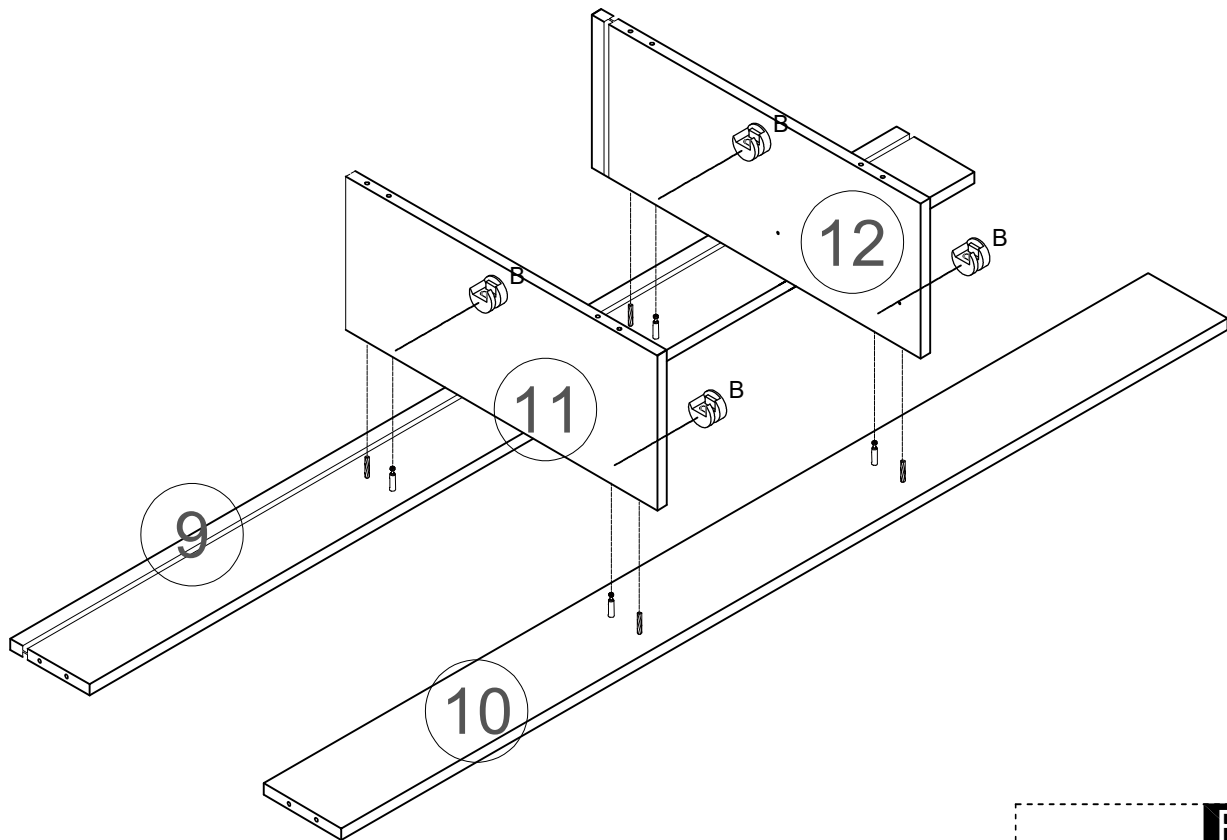

B x4

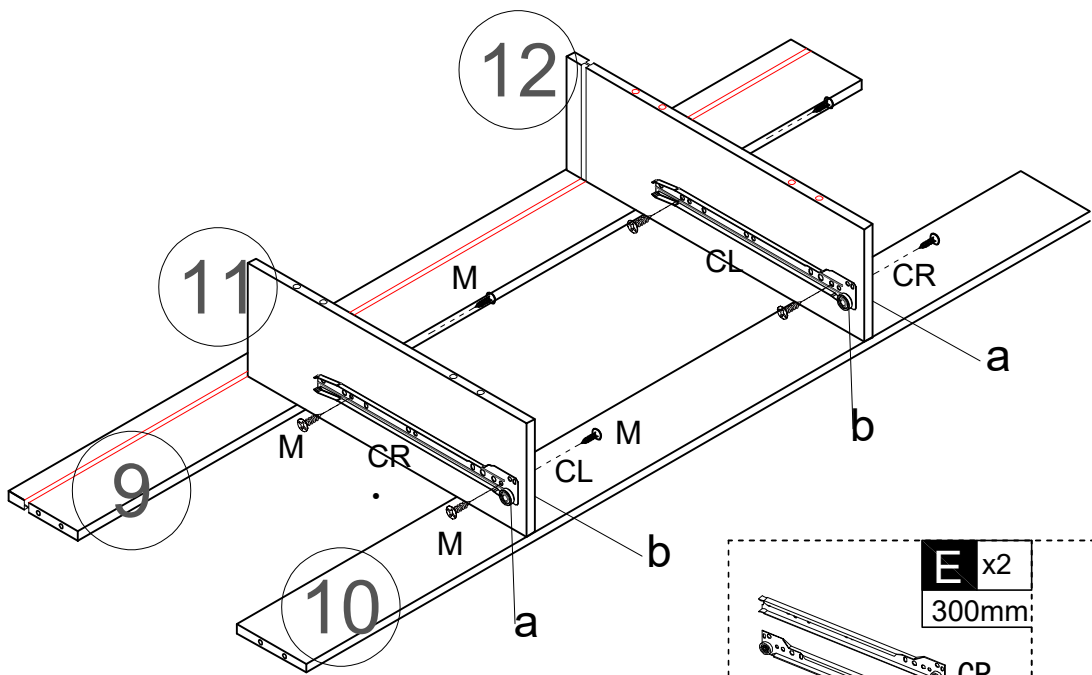
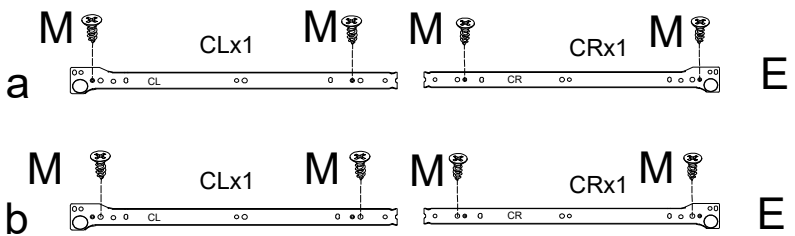

E x2
300mm

M x8
M3.5*12

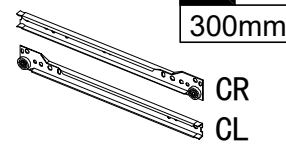

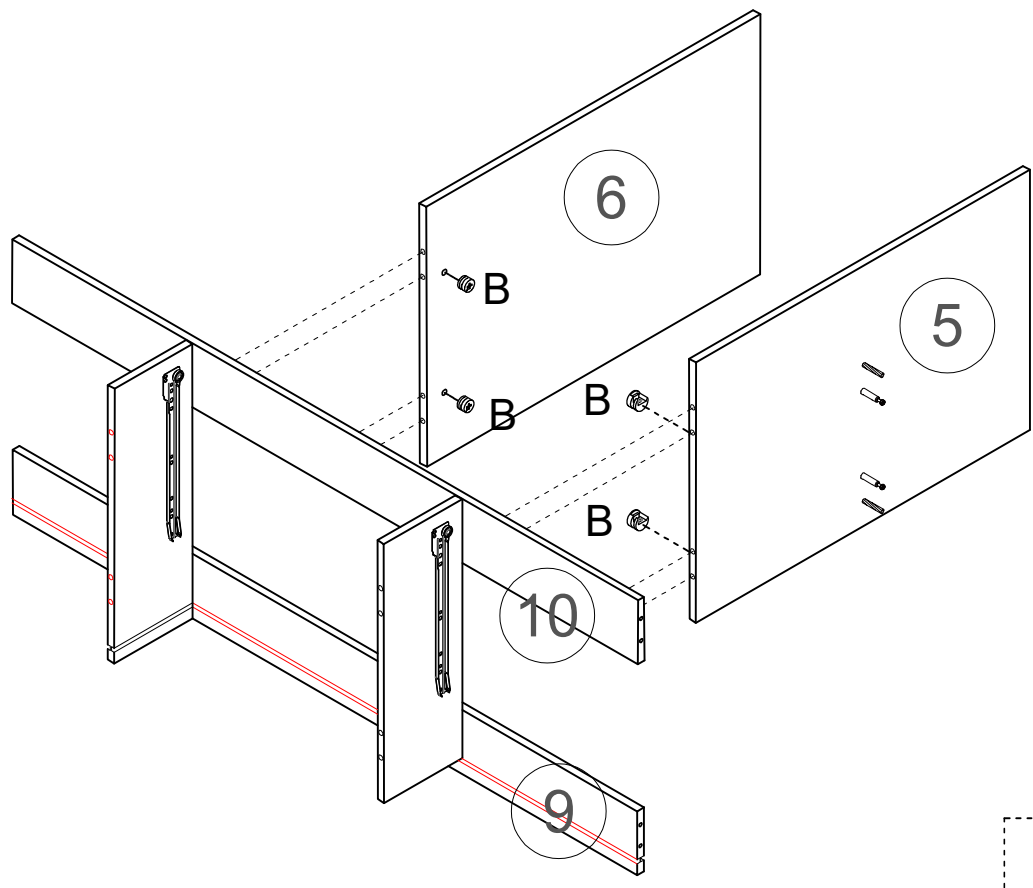

B x4

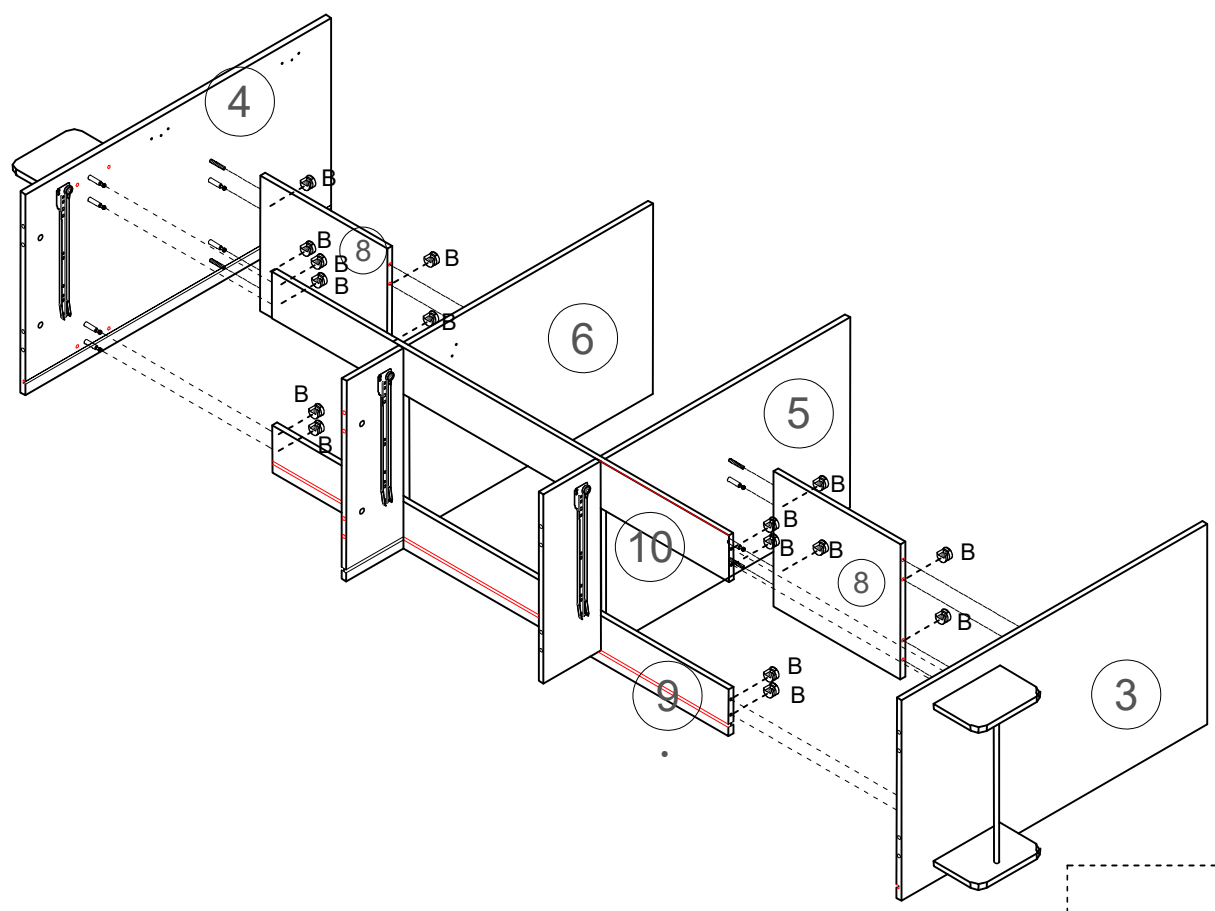

B x16



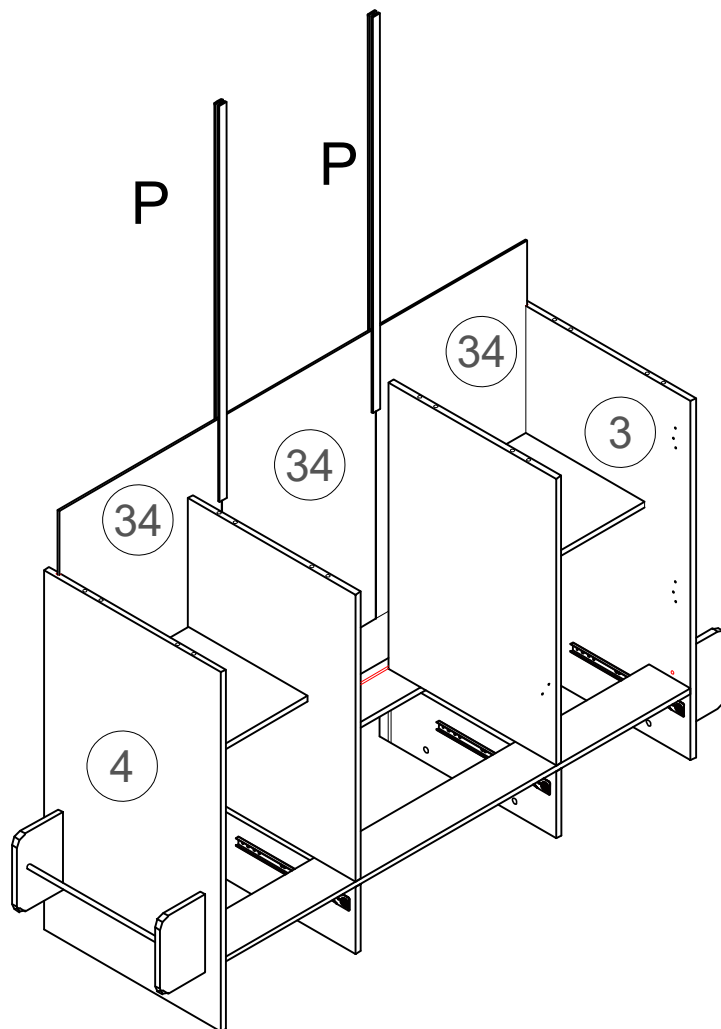

P x2
601mm

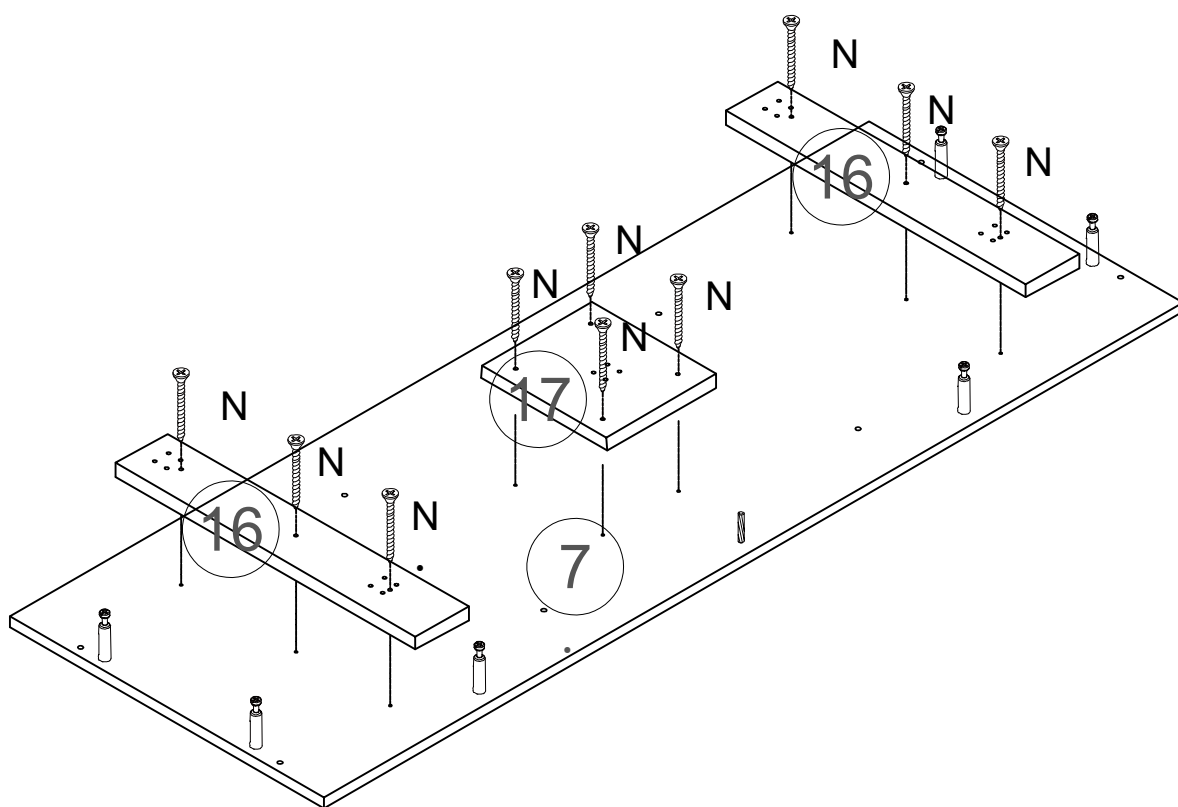

N x10
M3.5*25

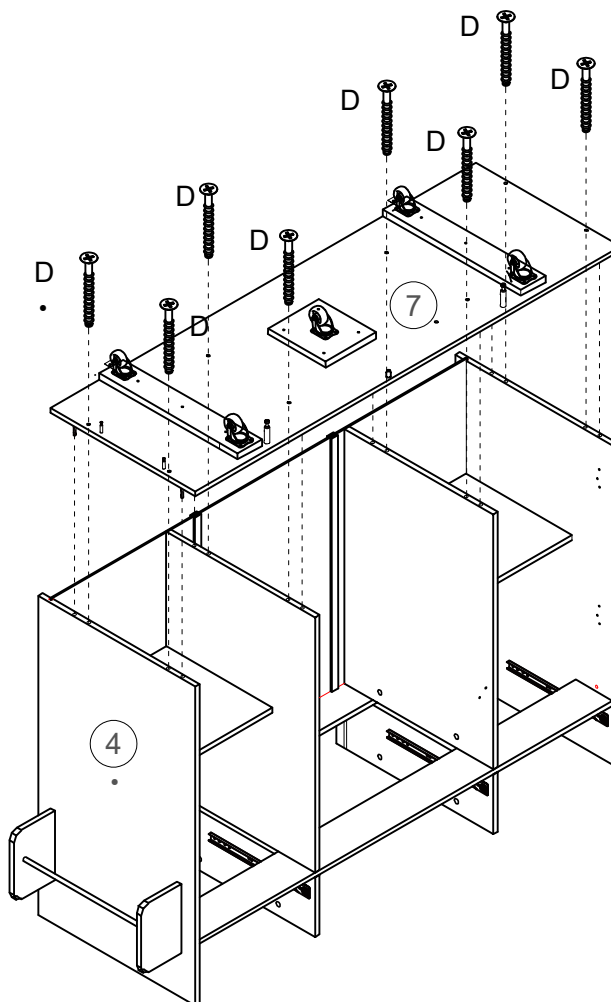
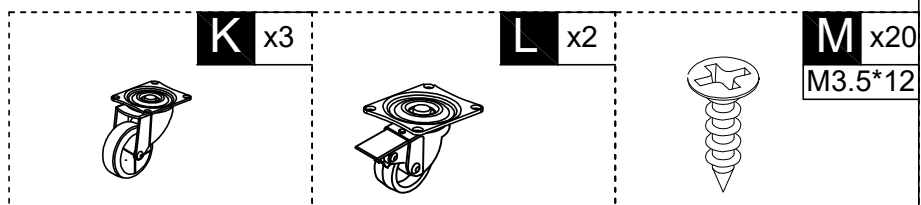
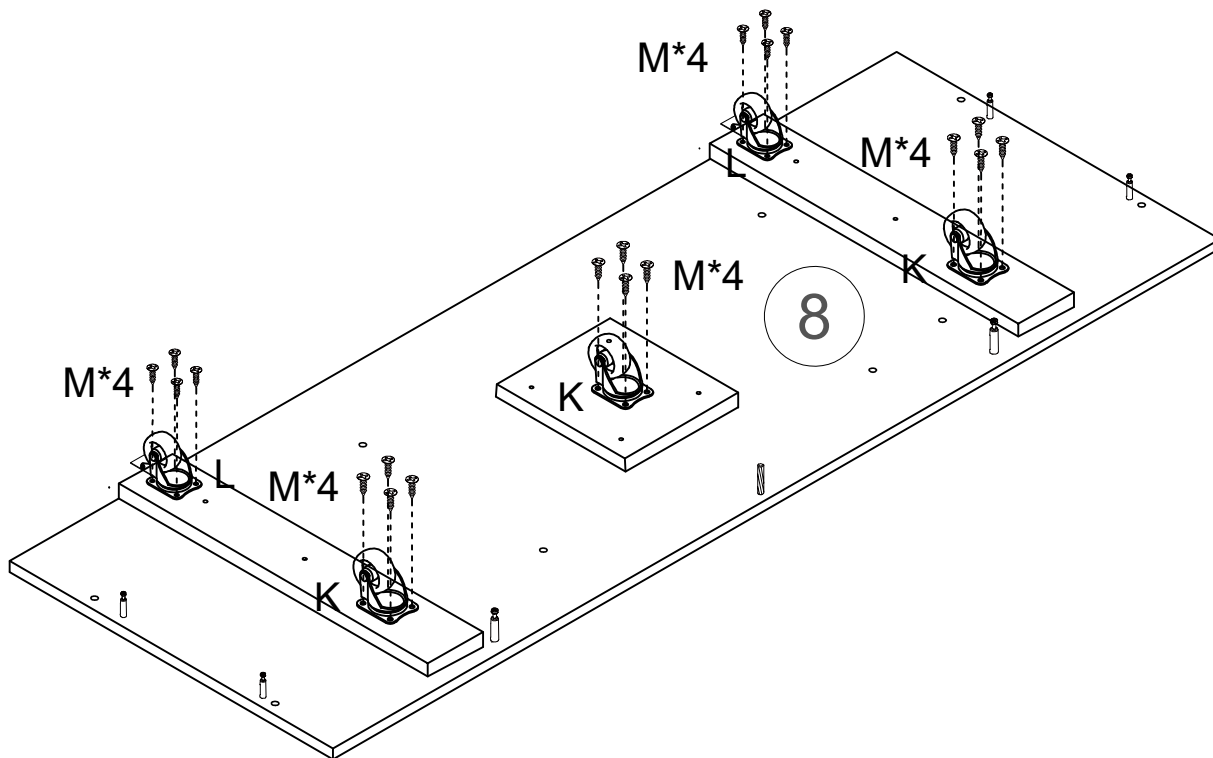

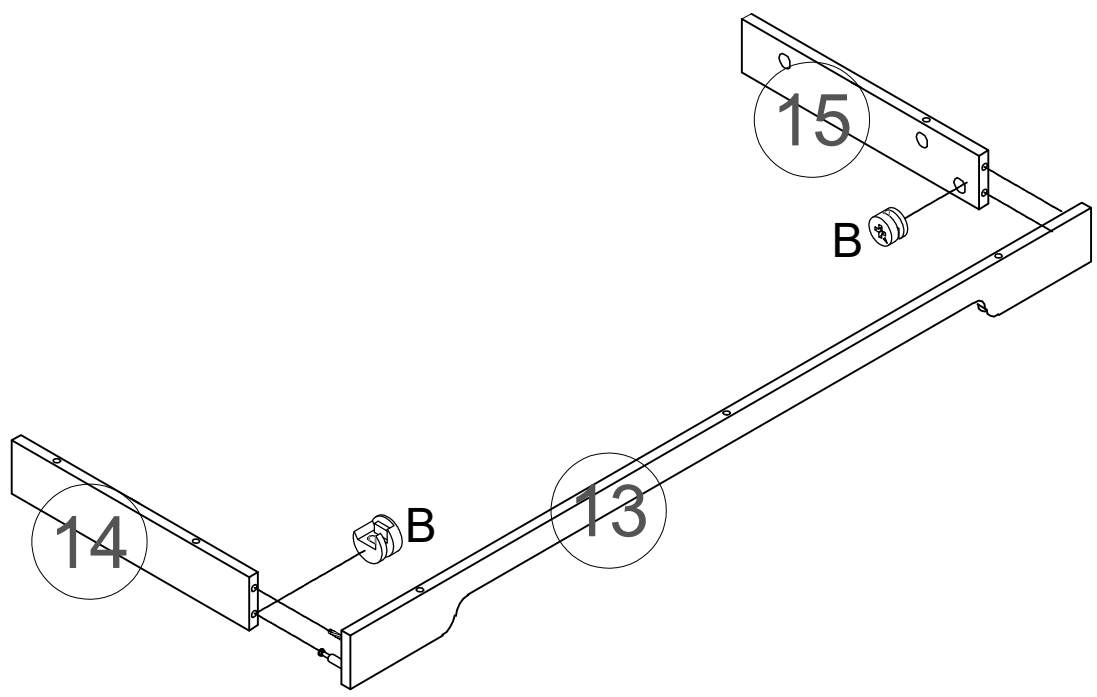

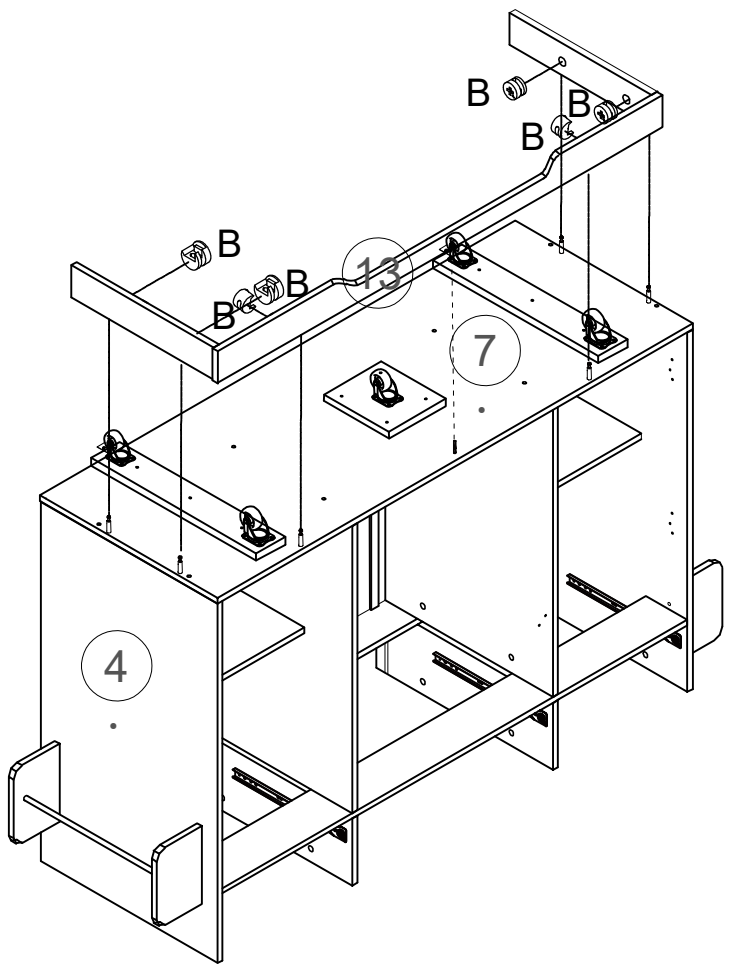

B x2



B x6

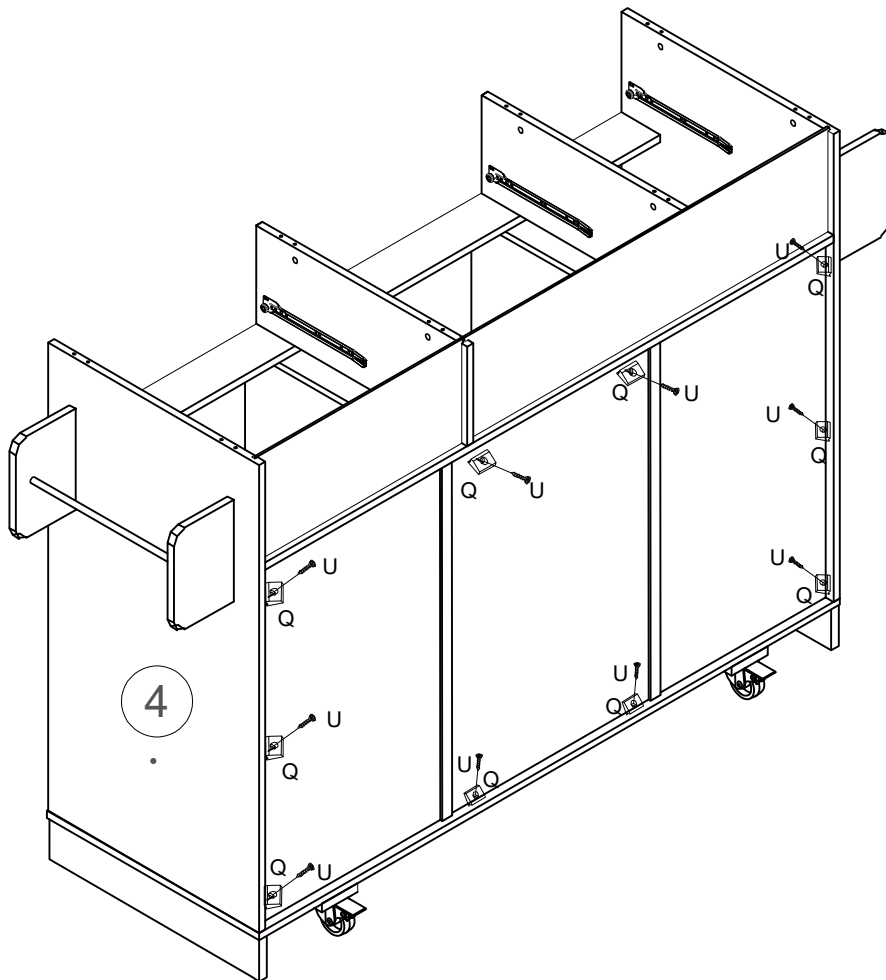
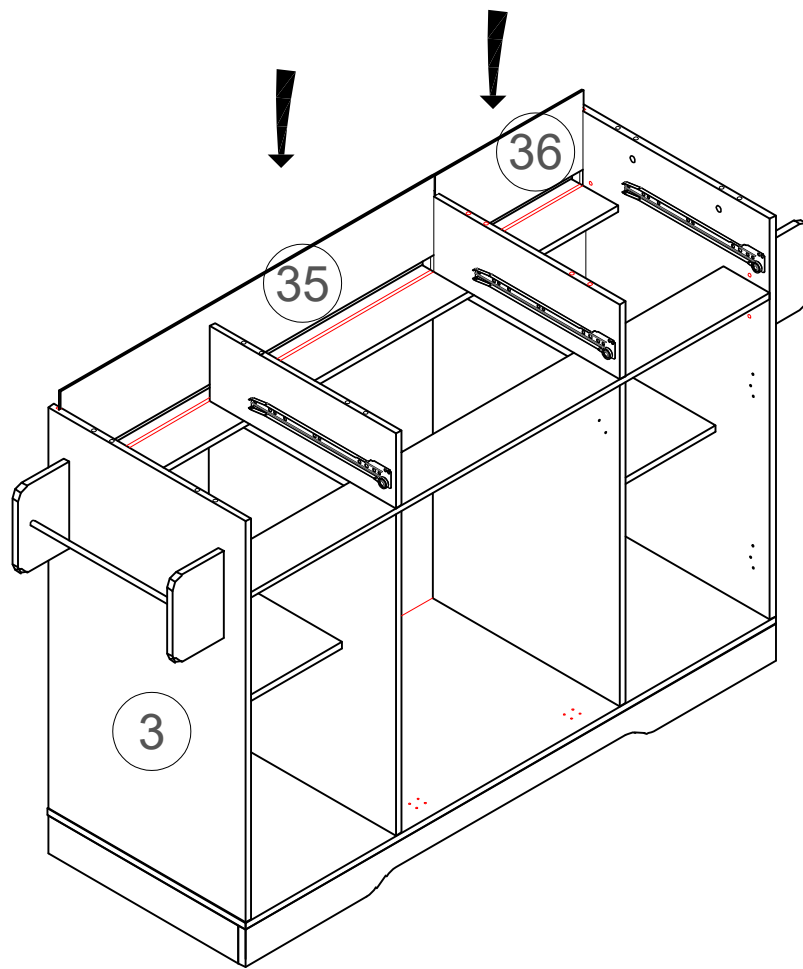



	U x10 M3*14
	Q x10

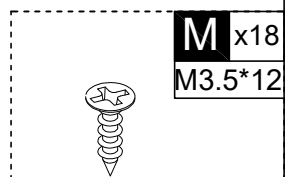
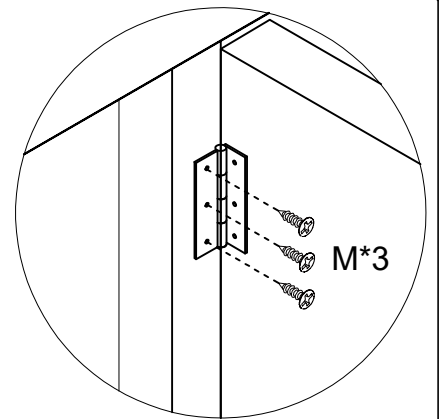
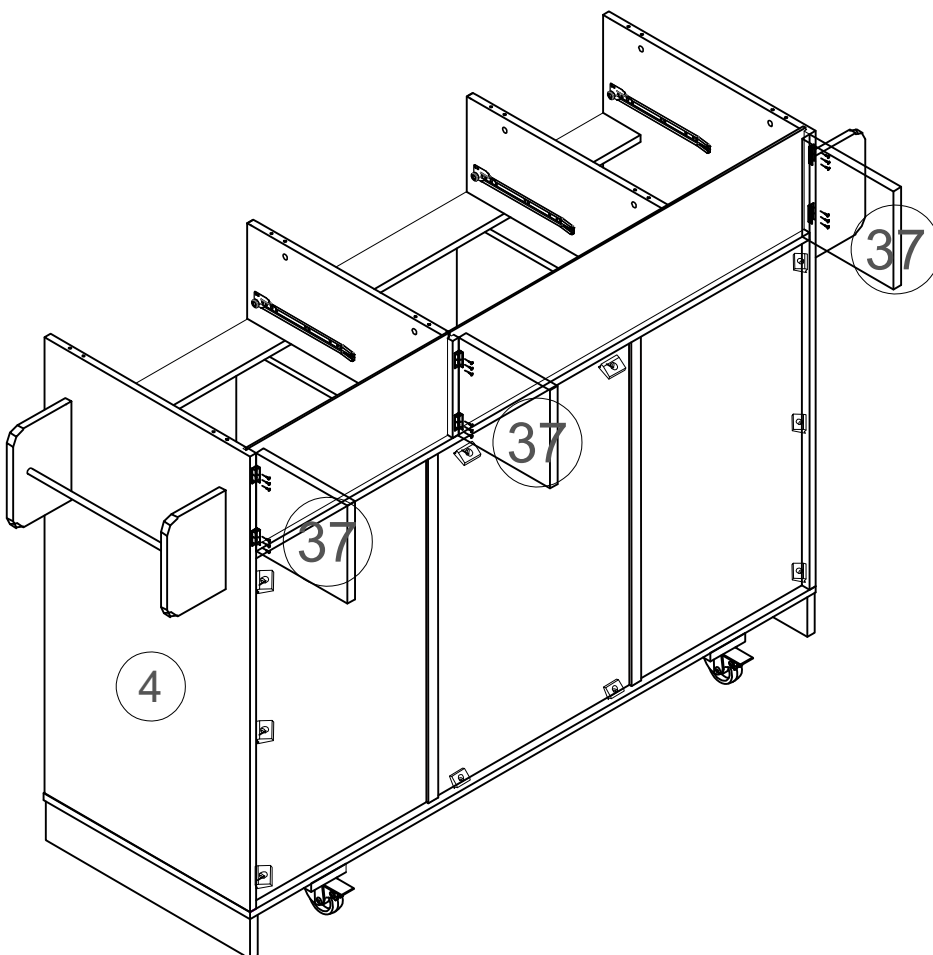
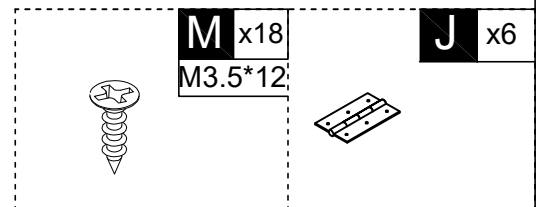
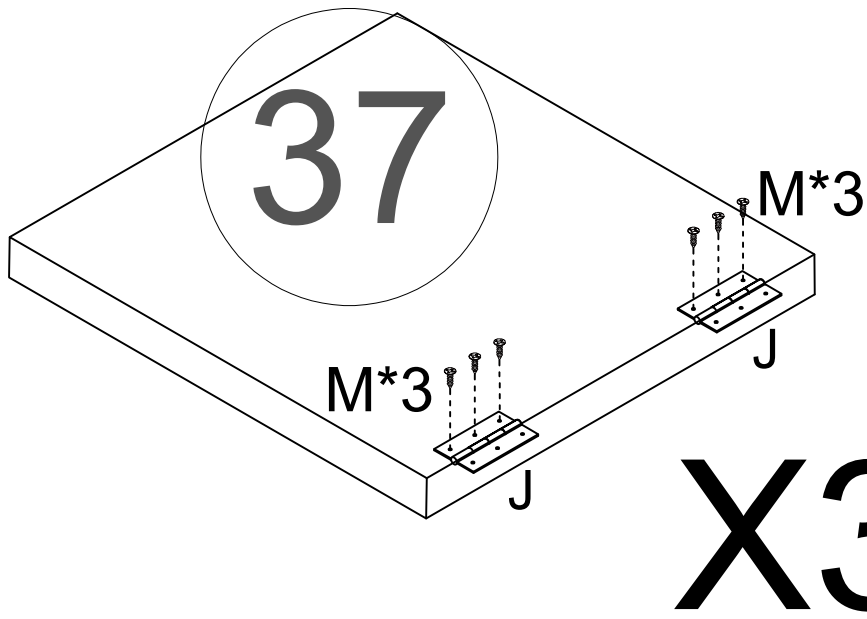

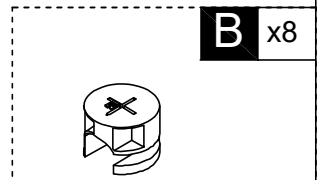
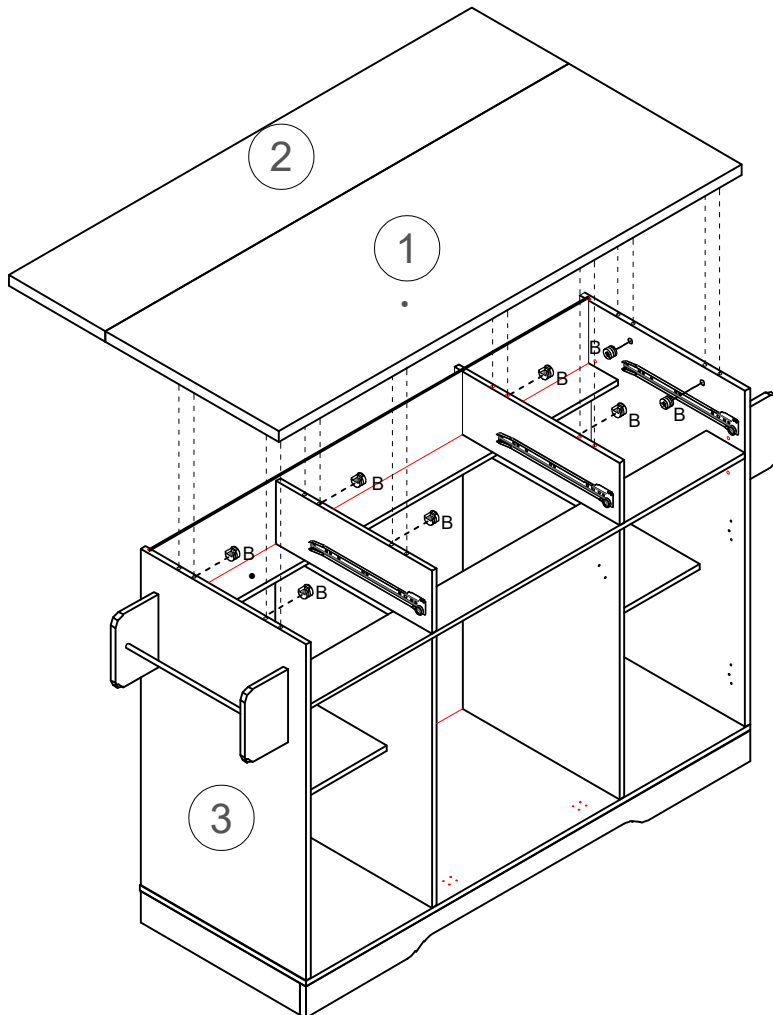
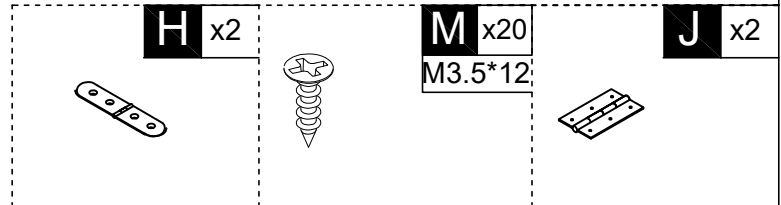
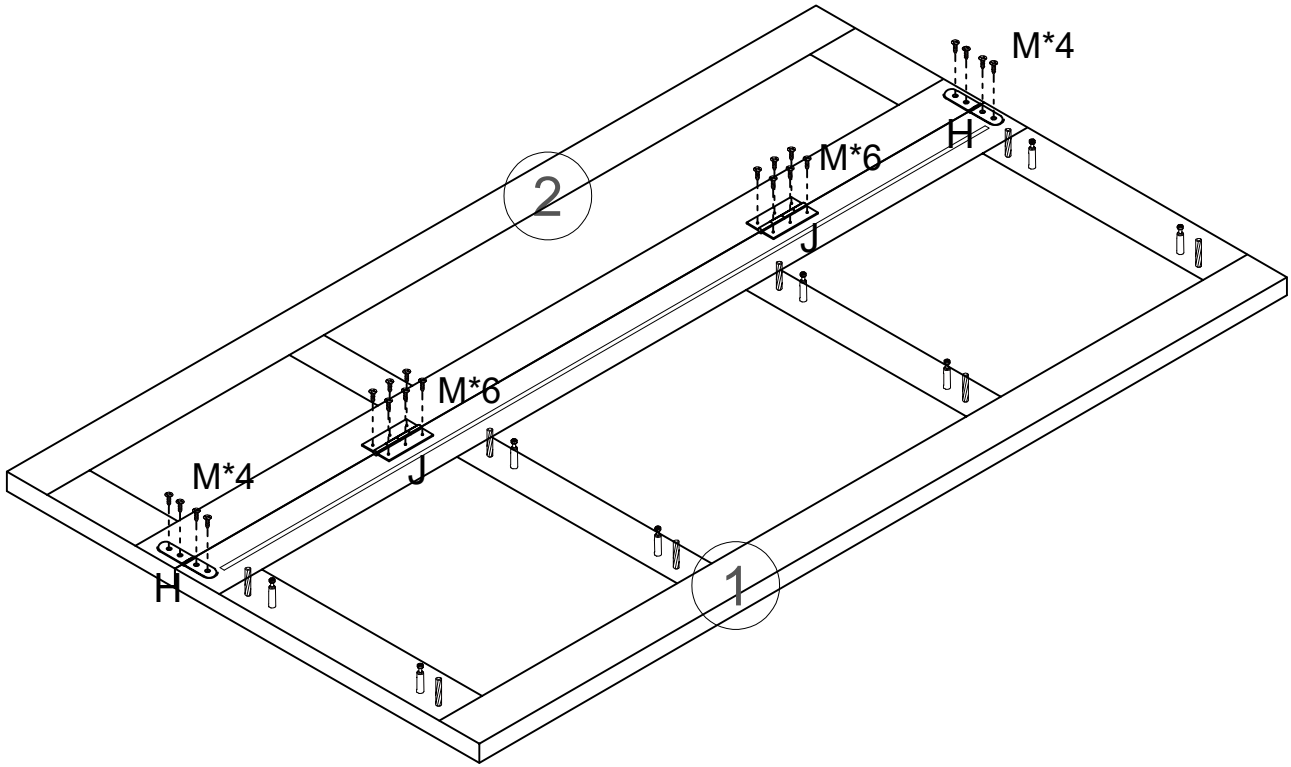

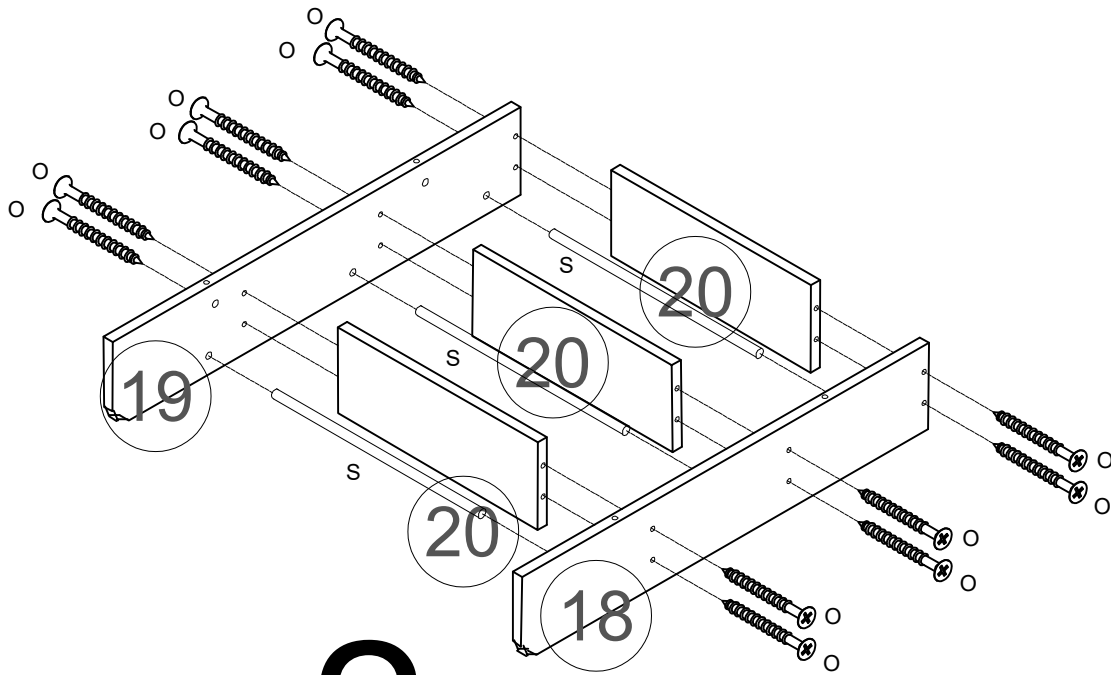

x 2

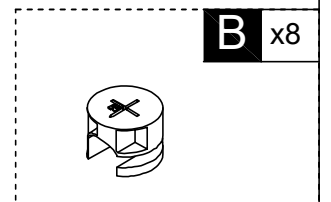
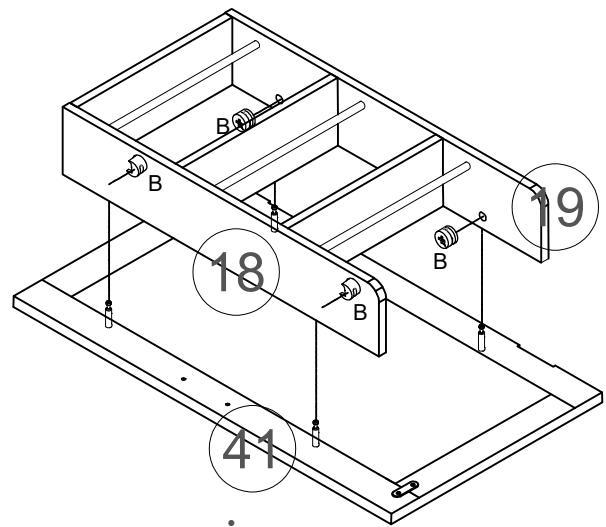
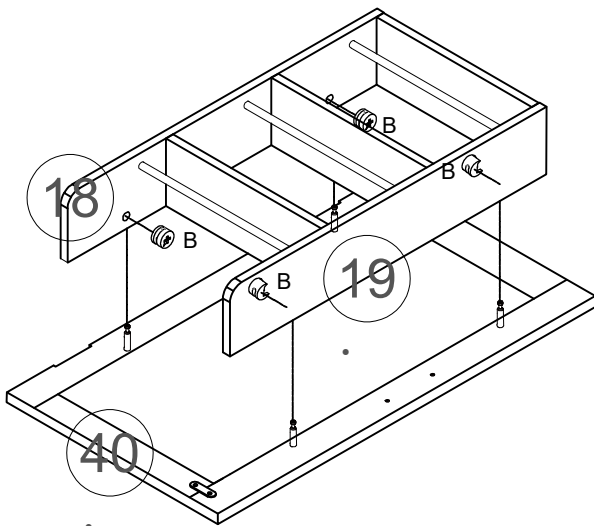
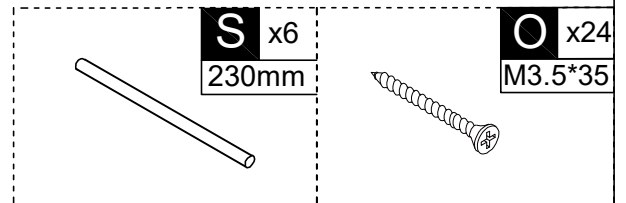

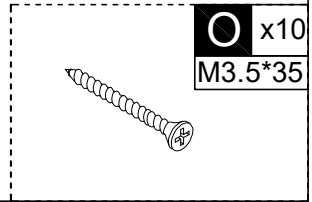
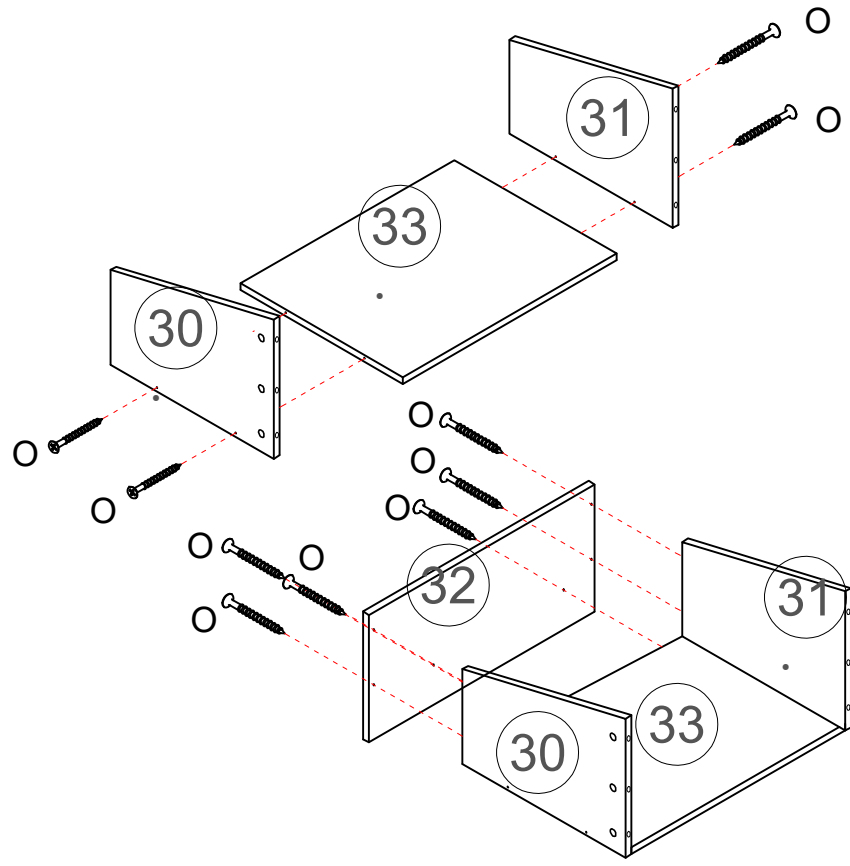
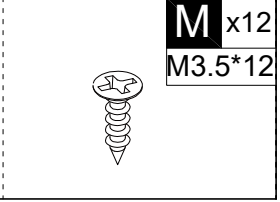
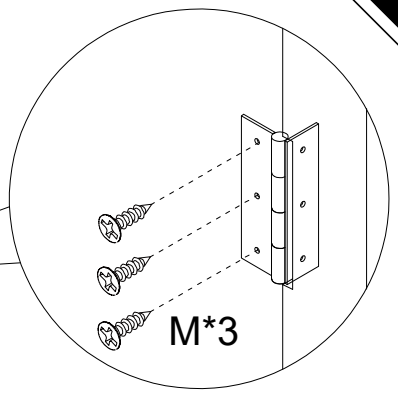
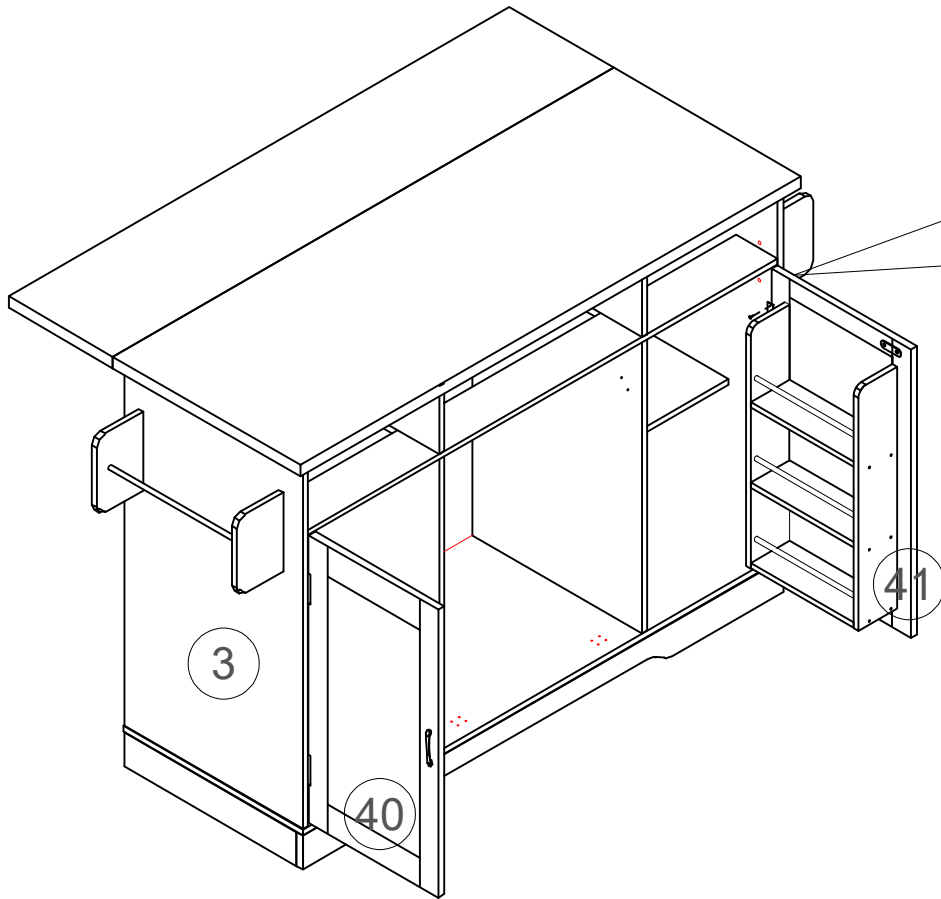

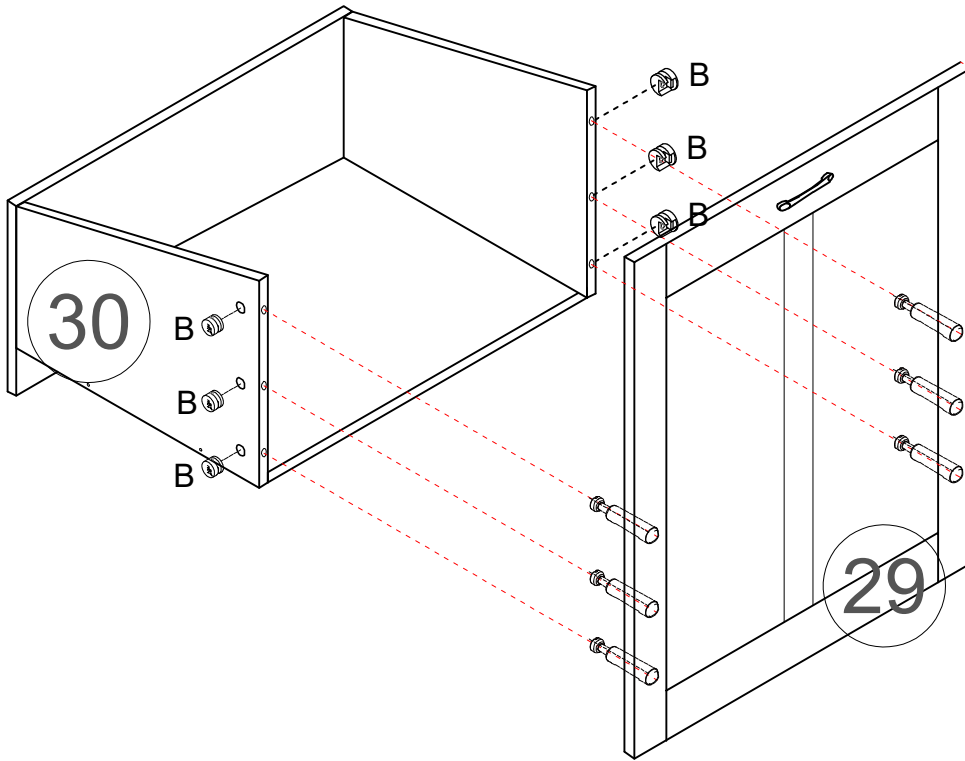

B x6

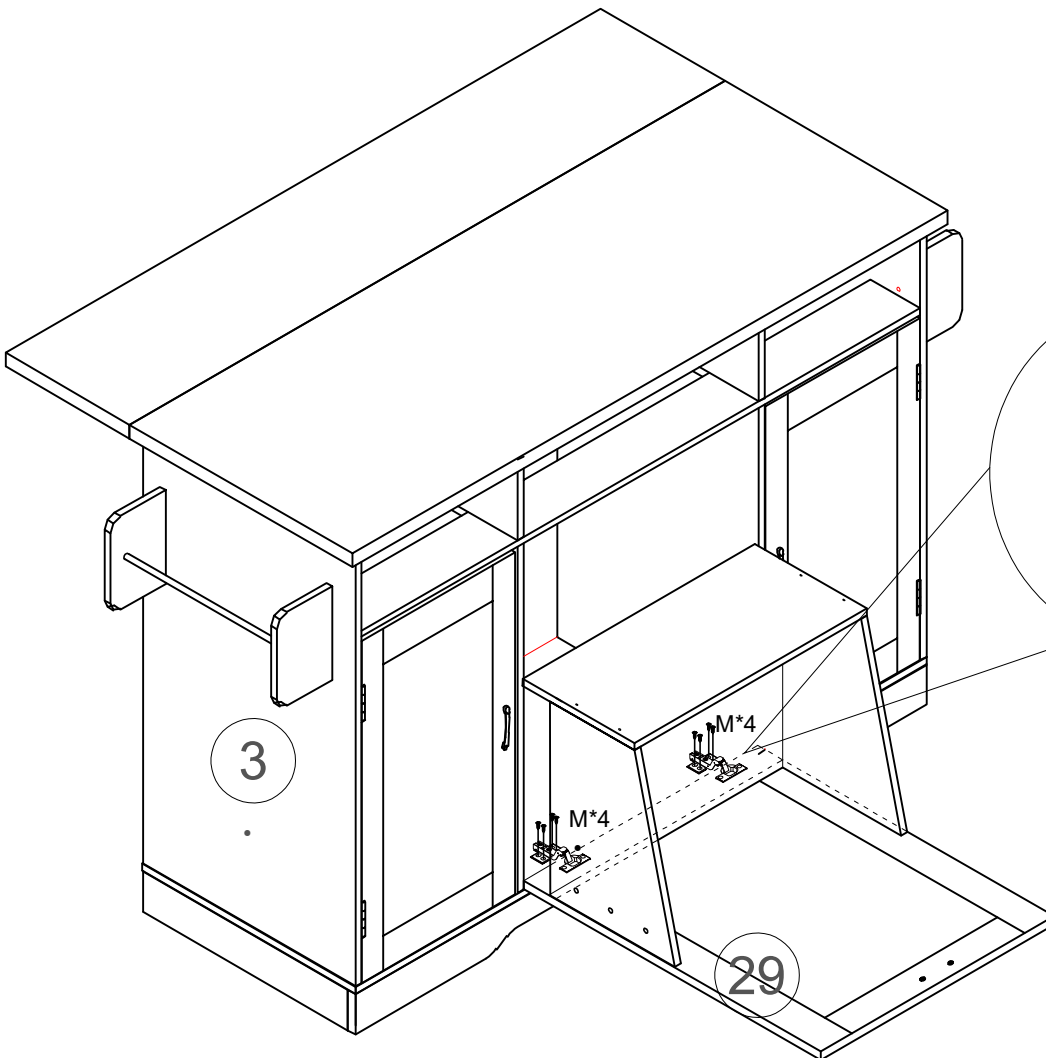

M x8
M3.5*12



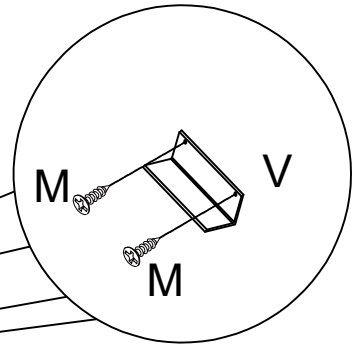
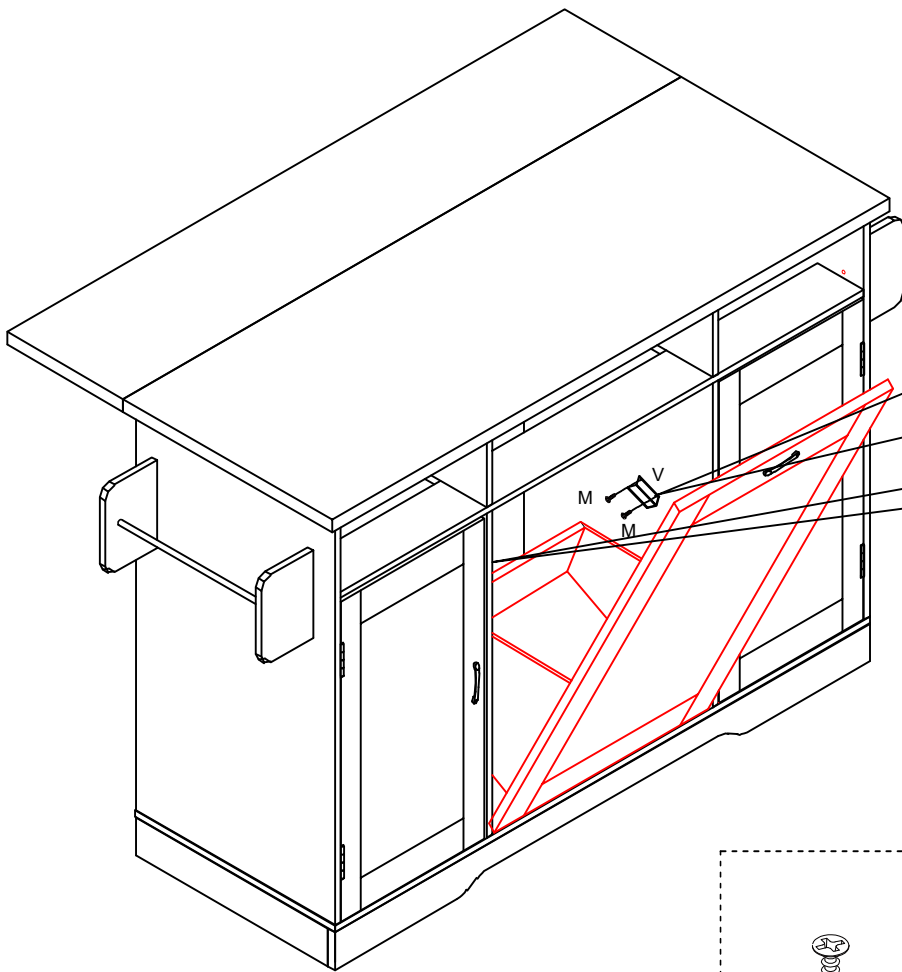

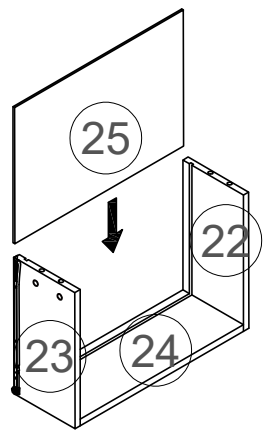
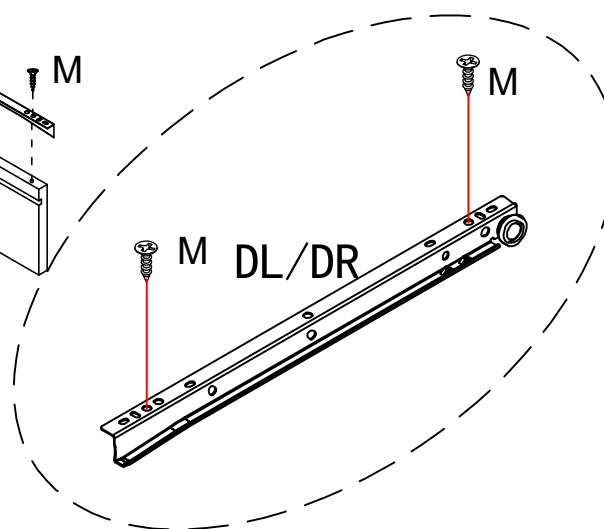
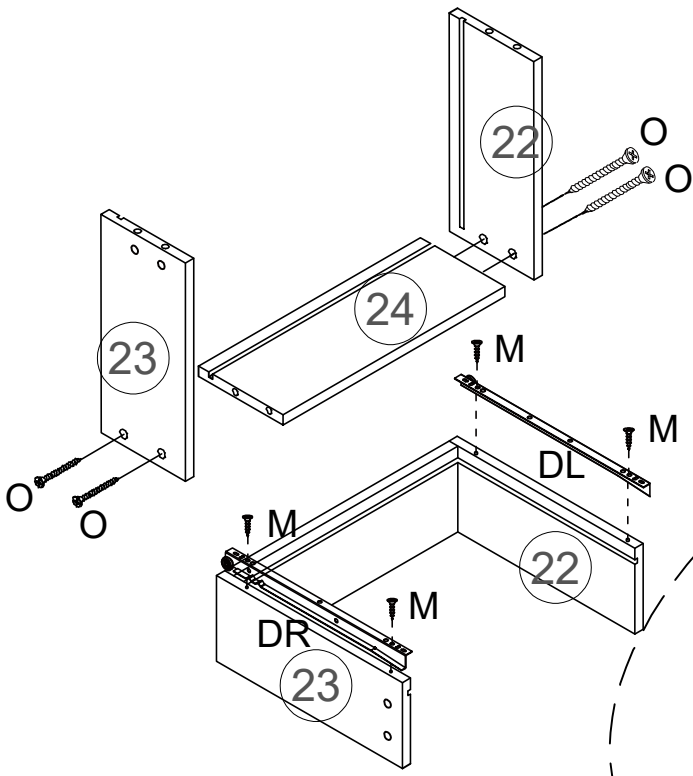

M x4 M3.5*12	V x2
------------------------	-------------

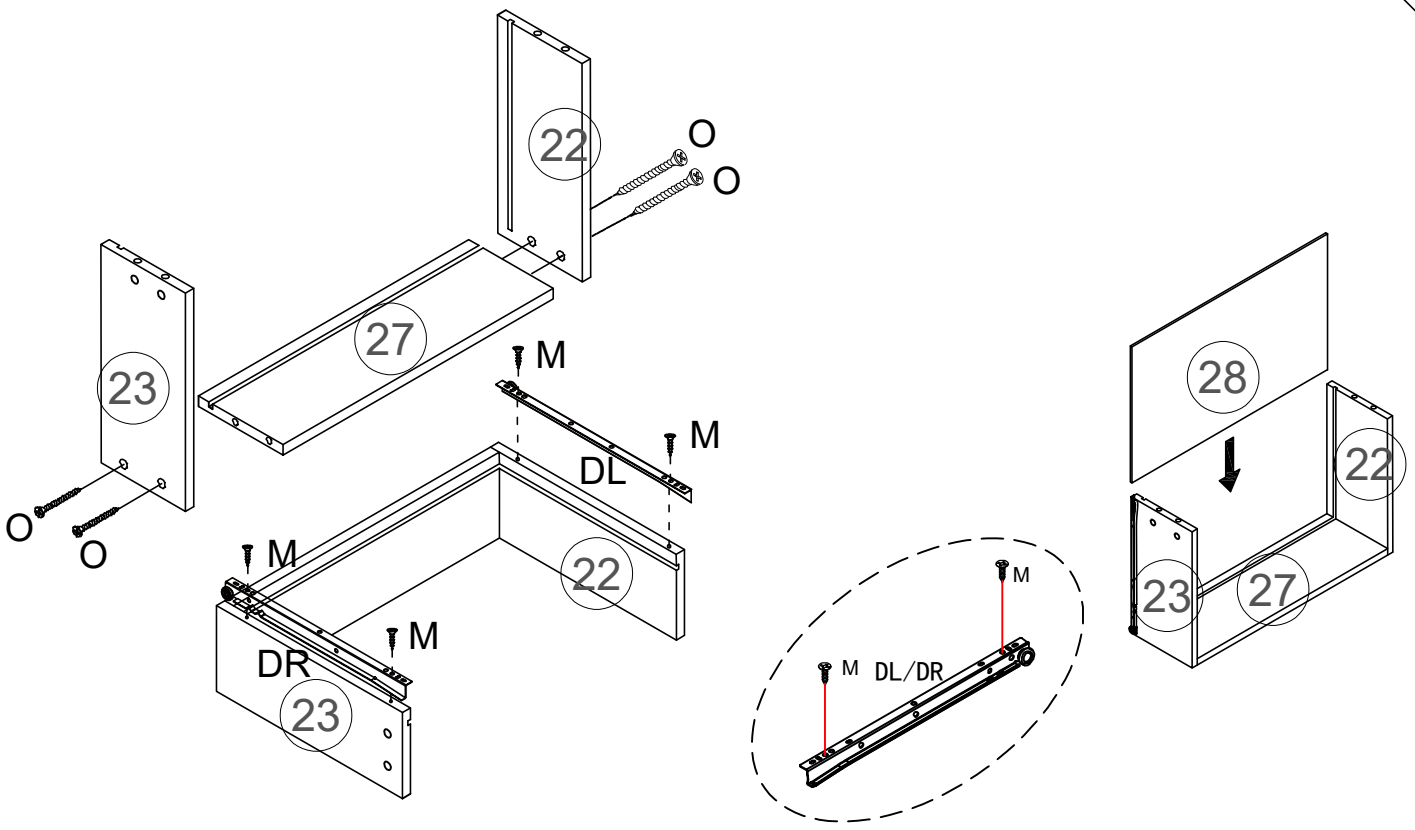

x 2

E x2 300mm	M x8 M3.5*12	O x8 M3.5*35
----------------------	------------------------	------------------------

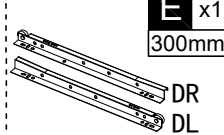

	E x1 300mm		M x4 M3.5*12		O x4 M3.5*35
	DR				
	DL				

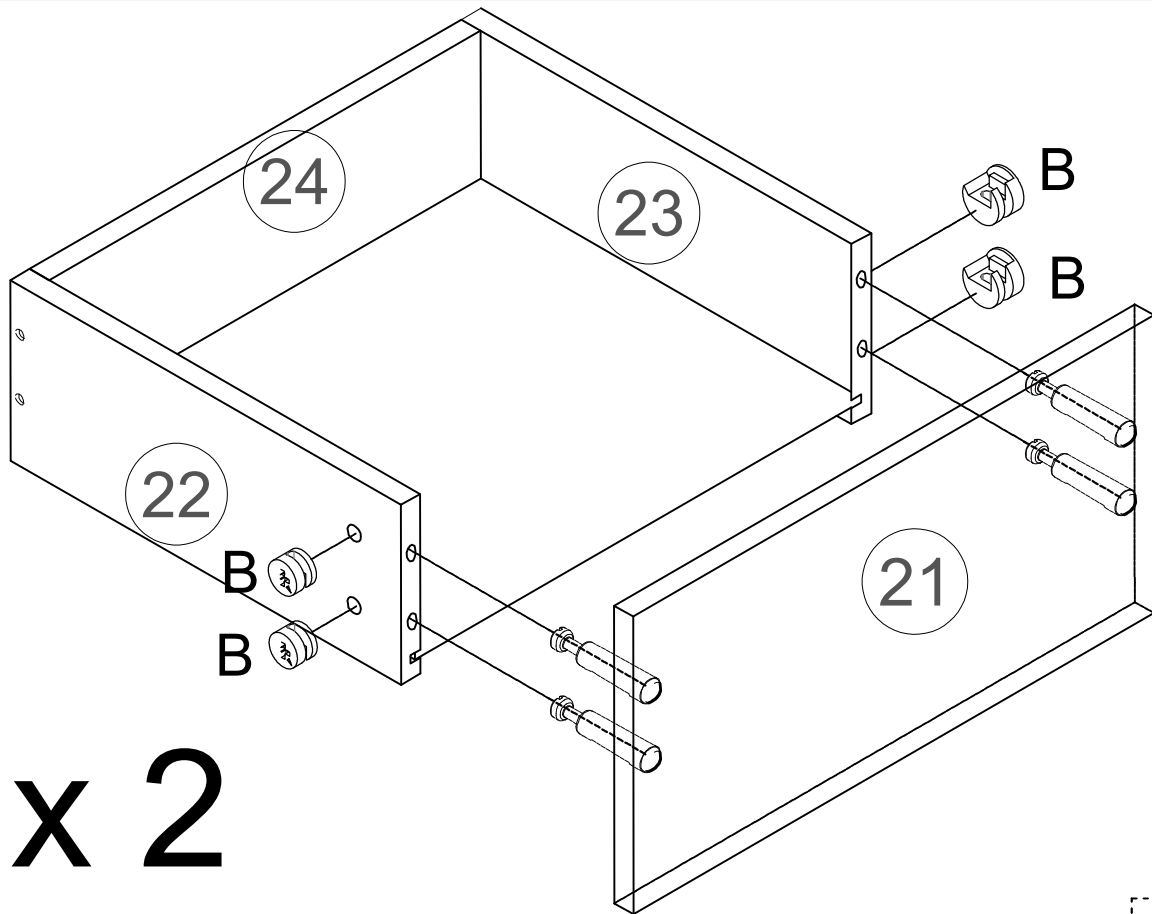

x 2

	B x8
---	-------------

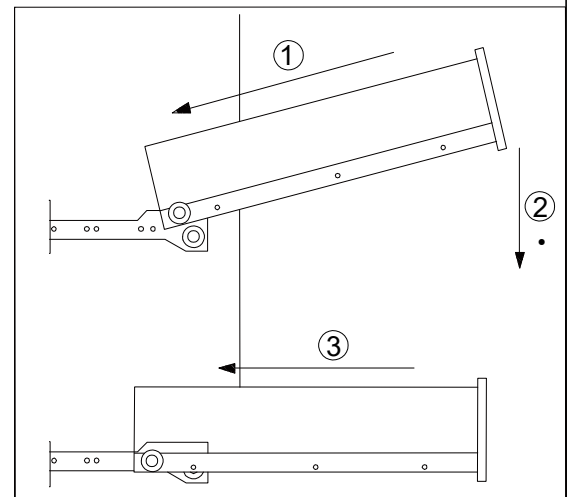
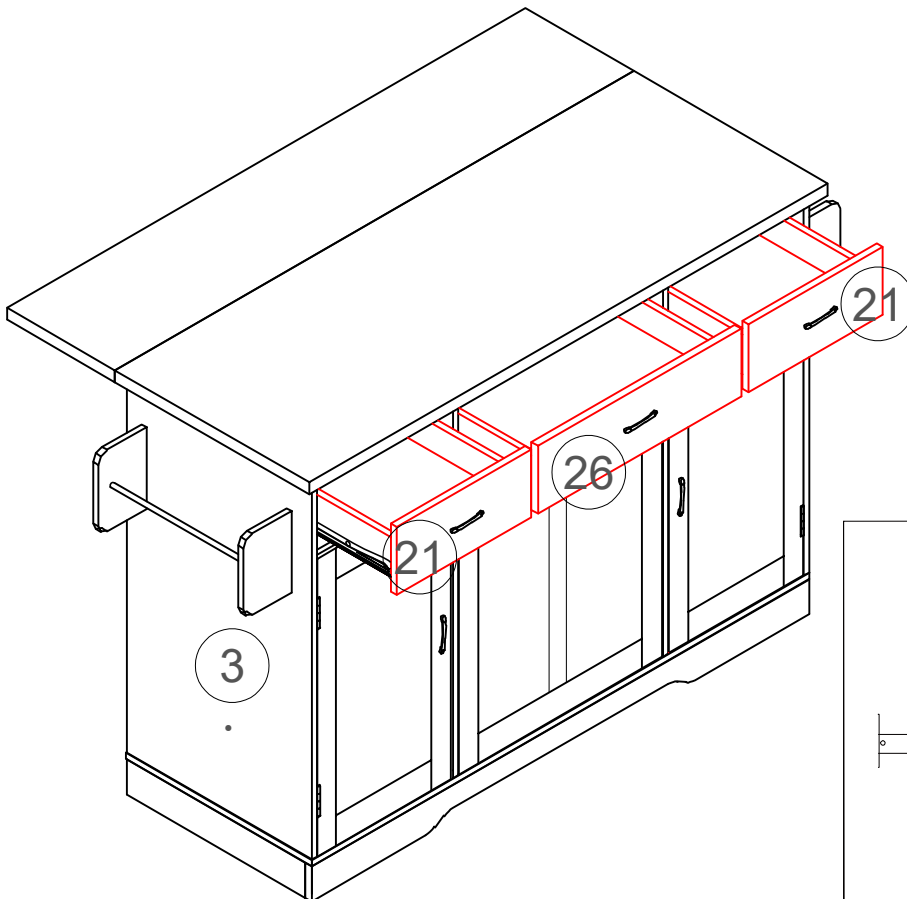
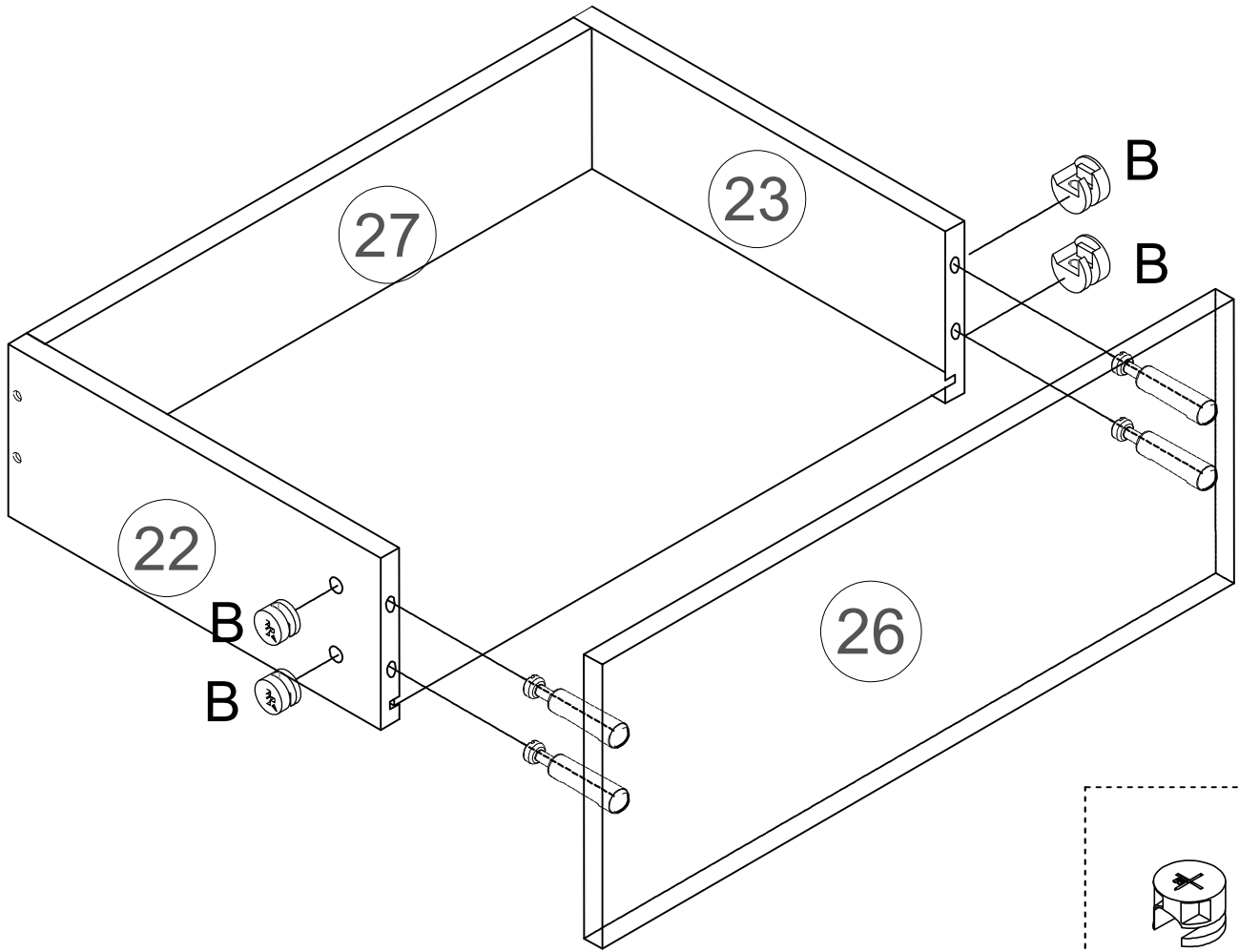

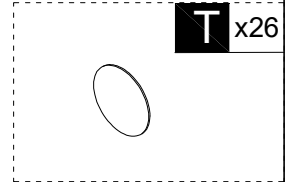
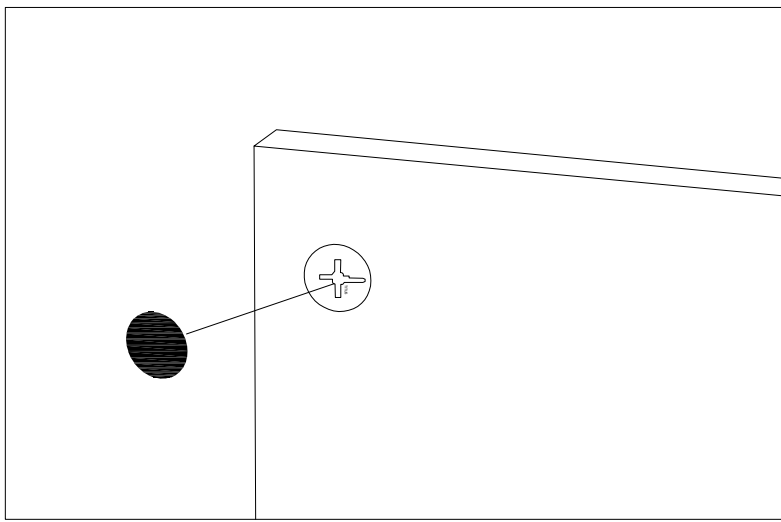

EN: After installing the product, stick the number **T** on the perforated position

FR: Une fois le produit installé, collez le numéro **T** à l'endroit où il y a des trous

DE: Nach der Installation des Produkts kleben Sie die Nummer **T** auf die perforierte Position

IT: Dopo l'installazione del prodotto, fissare il numero **T** sulla posizione perforata

ES: Después de instalar el producto, pegue el número **T** en la posición perforada

