

MONTAGEANLEITUNG/INSTRUCTIONS DE MONTAGE/ /ASSEMBLY INSTRUCTION

Artikelnummer/Item Number:

N622P306818W

N622P306819W

Dieses Set ist in 2 Boxen enthalten. Wenn Sie keine vollen 2 Boxen erhalten wenden Sie sich bitte an unseren Kundenservice.

This set comes in 2 boxes. If you do not receive a full 2 boxes, please contact our customer service

WOODEN NORDIC BED 200 x 90cm

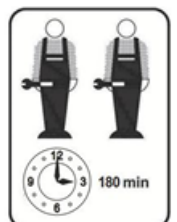
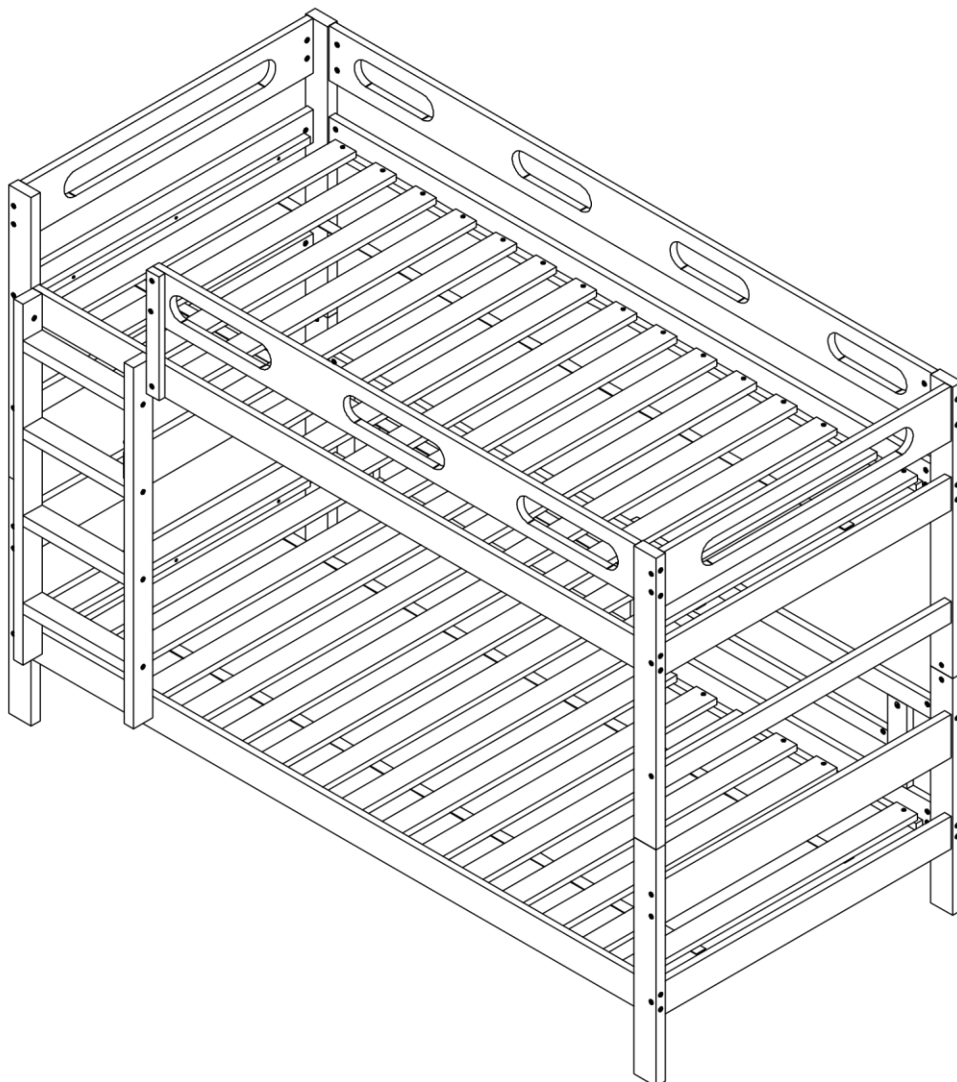

English

IMPORTANT ! KEEP FOR FUTURE REFERENCE : READ CAREFULLY

- To be assembled by an adult. Assembly must be checked by an adult before use
- WARNING ! Keep all screws, small parts and plastic bags out of the reach of children
- Properly identify all parts before assembling
- Never use your item if any of its parts are broken or missing
- Should any problems arise, please contact our After Sales Service
- Manufacturer's instructions shall be followed at all times
- Care: Clean with a soft, dry cloth. In case of larger stains, carefully rub with a slightly damp, non-abrasive sponge
- Avoid the risk of fire by not placing furniture near sources of ignition or hot items
- Do not jump on the bed

Deutsch

WICHTIG ! ZUM SPÄTEREN NACHSCHLAGEN AUFBEWAHREN: SORGFÄLTIG LESEN

- Muss von einem Erwachsenen zusammengebaut werden. Der Zusammenbau muss vor dem Gebrauch von einem Erwachsenen überprüft werden
- WARNUNG! Bewahren Sie alle Schrauben, Kleinteile und Plastikbeutel außerhalb der Reichweite von Kindern auf
- Kennzeichnen Sie vor dem Zusammenbau alle Teile richtig
- Benutzen Sie Ihren Artikel niemals, wenn Teile gebrochen sind oder fehlen
- Sollten Probleme auftreten, wenden Sie sich bitte an unseren Kundendienst
- Die Anweisungen des Herstellers sind stets zu befolgen
- Pflege: Mit einem weichen, trockenen Tuch reinigen. Bei größeren Flecken vorsichtig mit einem leicht feuchten, nicht scheuernden Schwamm abreiben. nicht scheuernden Schwamm
- Vermeiden Sie die Gefahr eines Brandes, indem Sie die Möbel nicht in der Nähe von Zündquellen oder heißen Gegenständen aufstellen
- Nicht auf das Bett springen

Français

IMPORTANT ! CONSERVER POUR RÉFÉRENCE ULTÉRIEURE : LIRE ATTENTIVEMENT

- Le montage doit être effectué par un adulte. Le montage doit être vérifié par un adulte avant Utilisation
- ATTENTION ! Tenir les vis, les petites pièces et les sachets en plastique hors de portée des enfants
- Identifiez correctement toutes les pièces avant de les assembler
- N'utilisez jamais votre article si l'une de ses pièces est cassée ou manquante
- En cas de problème, veuillez contacter notre service après-vente
- Les instructions du fabricant doivent être respectées à tout moment
- Entretien : nettoyer avec un chiffon doux et sec. En cas de taches plus importantes, frotter soigneusement avec une éponge non abrasive légèrement humide. légèrement humide et non Abrasive
- Évitez les risques d'incendie en ne plaçant pas les meubles à proximité de sources d'inflammation ou d'objets chauds
- Ne pas sauter sur le lit

Italiano

IMPORTANTE! CONSERVARE PER RIFERIMENTO FUTURO: LEGGERE ATTENTAMENTE

- Deve essere assemblato da un adulto. L'assemblaggio deve essere controllato da un adulto prima dell'uso
- **ATTENZIONE!** Tenere tutte le viti, le piccole parti e i sacchetti di plastica fuori dalla portata dei bambini
- Identificare correttamente tutte le parti prima dell'assemblaggio
- Non utilizzare mai l'articolo se alcune parti sono rotte o mancanti
- In caso di problemi, si prega di contattare il nostro Servizio Post Vendita
- Le istruzioni del produttore devono essere sempre seguite
- Cura: Pulire con un panno morbido e asciutto. In caso di macchie più estese, strofinare accuratamente con una spugna leggermente umida e nonspugna leggermente umida e non abrasiva
- Evitare il rischio di incendio, non collocando i mobili vicino a fonti di accensione o a oggetti caldi
- Non saltare sul letto

Español

¡ IMPORTANTE ! CONSERVELO PARA FUTURAS CONSULTAS: LEA ATENTAMENTE

- Debe ser montado por un adulto. El montaje debe ser comprobado por un adulto antes del uso
- ADVERTENCIA Mantenga todos los tornillos, piezas pequeñas y bolsas de plástico fuera del alcance de los niños.
- Identifique correctamente todas las piezas antes de montarlas
 - Nunca utilice su artículo si alguna de sus piezas está rota o falta
 - Si surge algún problema, póngase en contacto con nuestro Servicio Postventa
 - Las instrucciones del fabricante deben seguirse en todo momento
 - Cuidado: Limpiar con un paño suave y seco. En caso de manchas más grandes, frote cuidadosamente con una esponja no abrasiva ligeramente humedecida.
 - Evite el riesgo de incendio no colocando los muebles cerca de fuentes de ignición u objetos calientes.
 - No saltar sobre la cama.

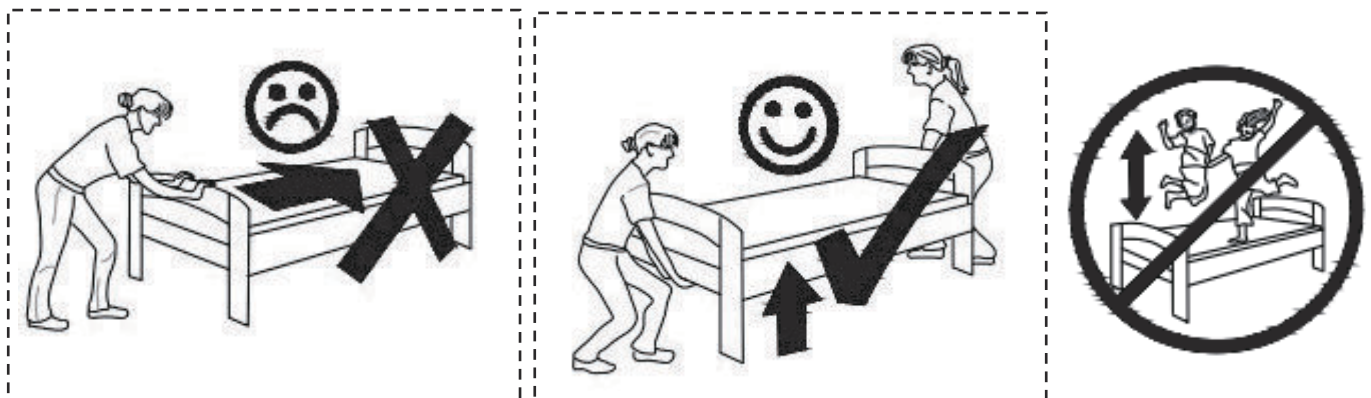

INSTRUCTIONS

IMPORTANT-READ CAREFULLY-RETAIN FOR FUTURE REFERENCE

- A) WARNING** -Children can become trapped between the bed and the wall, the adjoining pieces of furniture (e.g. cupboards) and the gap. To avoid risk of serious injury the distance between the safety barrier and the adjoining structure shall not exceed 7.5cm or shall be more than 23cm.
- B) WARNING** -Do not use the bed if any structural part is broken or missing; Replacement parts are between requested from the manufacturer or the store.
- C) WARNING** -Do not climb or wiggle on any non-designated structures.
- D) WARNING** -Product must be attached to wall or building structure. Always follow the manufacturer's instructions.
- E) WARNING** -The upper bed is not suitable for children under six years due to the risk of injury from falls.
- F) WARNING** -Bunk beds / high beds can present a serious risk of injury from strangulation if not used correctly. Never attach or hang items to any part of the bunk bed / high bed that are not designed to be used with the bed, for example, but not limited to ropes, strings, cords, hooks, belts and bags
- G) The recommended size of the mattress to be used with the bed is **200X90cm**, maximum thickness mattress: **14cm**.**
- H) It is necessary to ventilate the room in order to maintain a low level moisture and prevent mold growth in the bed and its periphery.**
- I) Joining devices should always be tightened properly and regularly verified. Tighten if necessary.**
- J) Meets European standard requirements NC safety **EN 747-1:2024**.**

ANLEITUNGEN

WICHTIG - SORGFÄLTIG LESEN - FÜR SPÄTERE VERWENDUNG AUFBEWAHREN

- A) WARNUNG** - Kinder können zwischen dem Bett und der Wand, den angrenzenden Möbelstücken (z.B. Schränken) und dem Icke eingeklemmt werden. Um das Risiko schwerer Verletzungen zu vermeiden, darf der Abstand zwischen der Sicherheitsbarriere und der angrenzenden Struktur 7.5 cm nicht überschreiten oder mehr als 23 cm betragen.
- B) WARNUNG** - Verwenden Sie das Bett nicht, wenn ein strukturelles Teil beschädigt oder fehlt; Ersatzteile sind beim Hersteller oder im Geschäft anzufordern.
- C) WARNUNG** - Klettern oder Wackeln auf nicht dafür vorgesehenen Strukturen ist untersagt.
- D) WARNUNG** -Das Produkt muss an der Wand oder der Gebäudestruktur befestigt werden. Befolgen Sie immer die Anweisungen des Herstellers.
- E) WARNUNG** - Das obere Bett ist nicht für Kinder unter sechs Jahren geeignet, da Verletzungsgefahr durch Stürze besteht.
- F) WARNUNG** - Etagenbetten / Hochbetten können ein ernsthaftes Verletzungsrisiko durch Erstickung darstellen, wenn sie nicht richtig verwendet werden. Befestigen oder hängen Sie niemals Gegenstände an irgendeinen Teil des Etagenbettes / Hochbettes, die nicht dafür vorgesehen sind, zum Beispiel, aber nicht beschränkt auf Seile, Schnüre, Kordeln, Haken, Gürtel und Taschen.
- G) Die empfohlene Größe der Matratze, die mit dem Bett verwendet werden soll, beträgt **200X90cm**, maximale Matratzenstärke: **14cm**.**
- H) Es ist notwendig, den Raum zu belüften, um ein niedriges Feuchtigkeitsniveau aufrechtzuerhalten und Schimmelbildung im Bett und dessen Umgebung zu verhindern.**
- I) Verbindungselemente sollten immer ordnungsgemäß angezogen und regelmäßig überprüft werden. Bei Bedarf anziehen.**
- J) Entspricht den europäischen Normanforderungen NC-Sicherheit **EN 747-1:2024**.**



DE: Vor dem Einbau die Schrauben in die Löcher stecken und festziehen, aber nicht bis 100%, 70% bis 80% anziehen reicht aus. Schließlich, nachdem alle Schrauben installiert sind, ziehen Sie alle Schrauben auf 100%.

Wenn Sie auf diese Probleme stoßen, wie z. B. Fehlausrichtung der Löcher oder Unfähigkeit, bestimmte Teile zu installieren, überprüfen Sie bitte, ob die Schrauben korrekt verwendet werden und passen Sie die Dichtigkeit der Schrauben an.

UK: Before installation, insert the screws into the holes and tighten them, but do not tighten them to 100%, 70% to 80% is sufficient. Finally, after all screws are installed, tighten all screws to 100%.

If you encounter these issues, such as if the holes cannot be aligned or some parts cannot be installed, please check if the screws are used correctly and adjust the tightness of the screws.

FR: Insérer la vis dans le trou avant la fin de l'assemblage, serrer la vis, mais ne pas serrer à 100%, 70% ~ 80% est correct. Enfin, une fois que toutes les vis sont bien serrées, toutes les vis sont serrées à 100%.

Si vous rencontrez ces problèmes, par exemple si les trous ne sont pas alignés ou si certaines pièces ne peuvent pas être montées, vérifiez que les vis sont utilisées correctement et ajustez leur serrage.

Wichtiger Hinweis: Bestätigen Sie bitte alle
Komponenten und Schrauben vor der Montage.
Bitte wenden Sie sich an uns, falls
einige Teile oder Schrauben im Paket
fehlend sind.



WARNUNG!
LASSEN SIE
KINDER NICHT
AN DEN
GITTERN HINHÄNGEN!

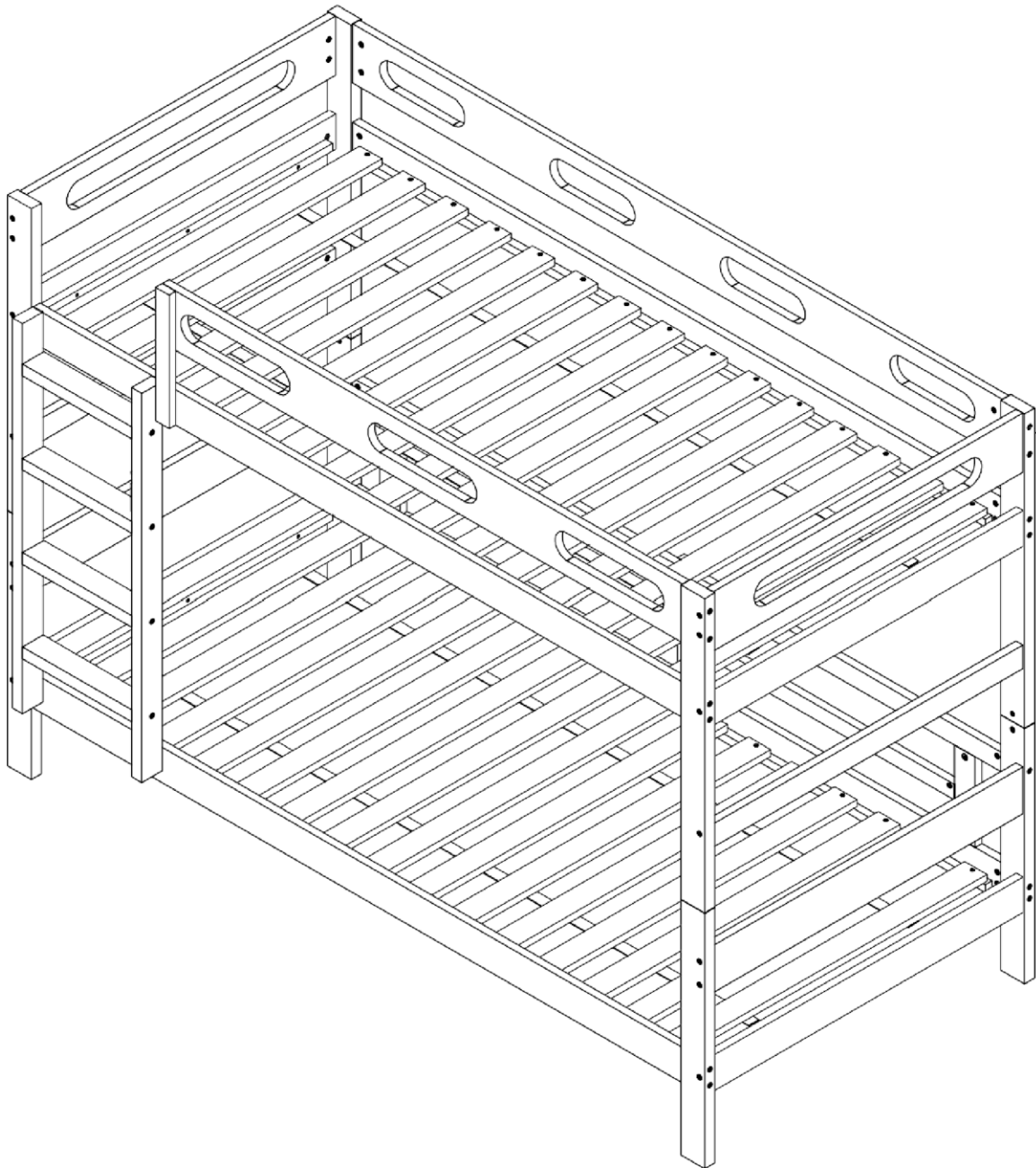

STÜCKLISTE

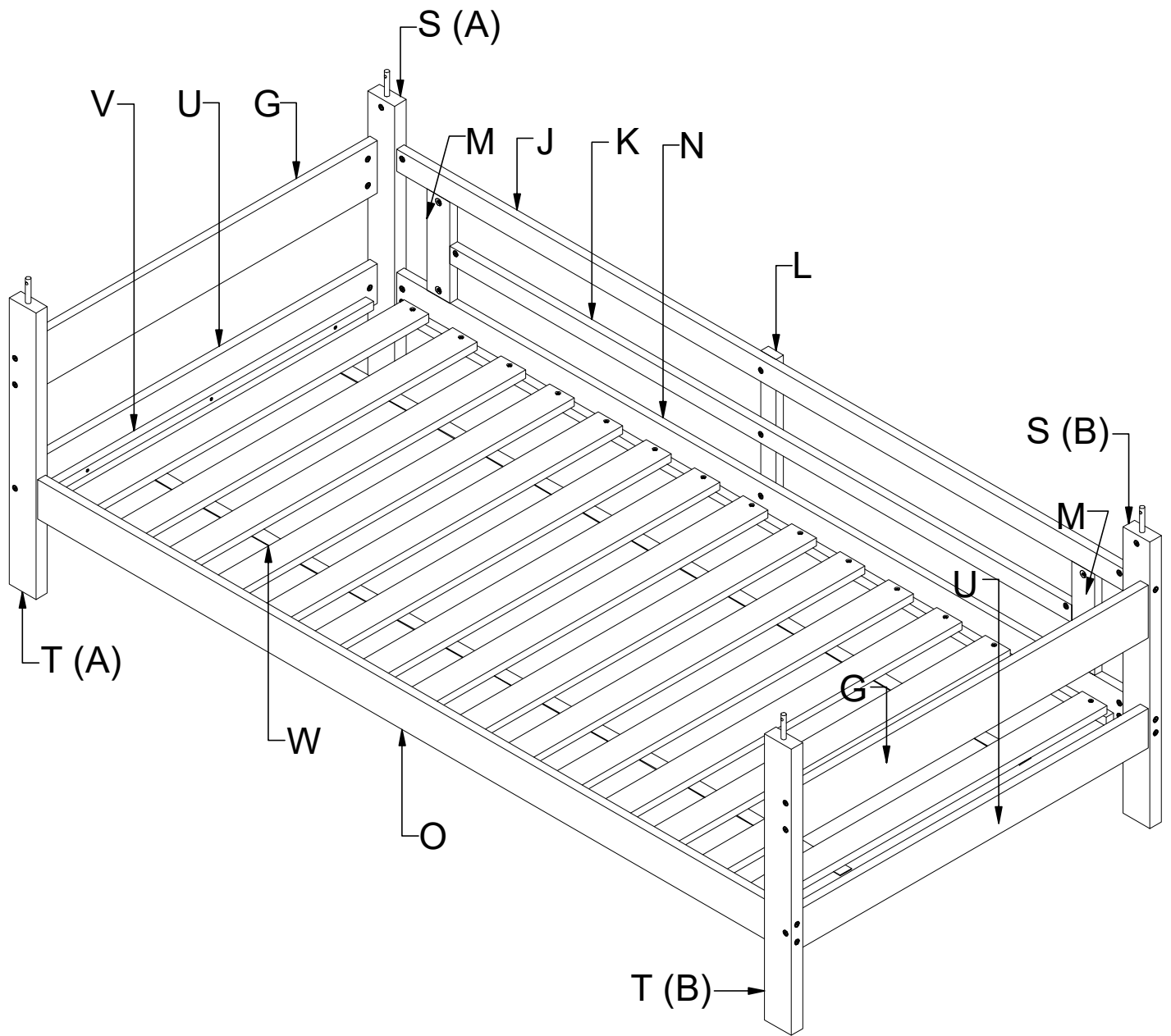

STÜCKLISTE

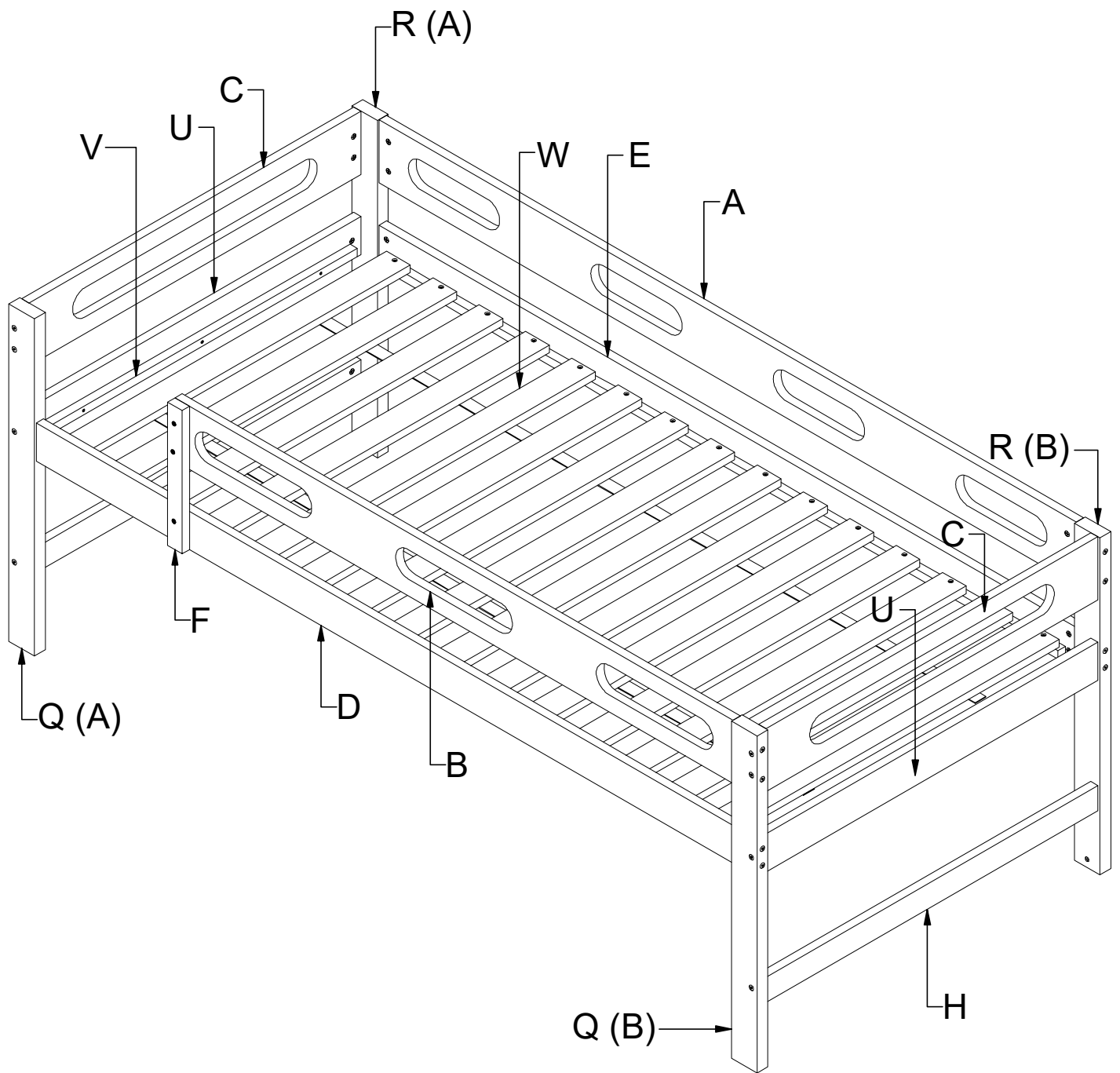





ASSEMBLY INSTRUCTION

INSTRUCTIONS DE MONTAGE

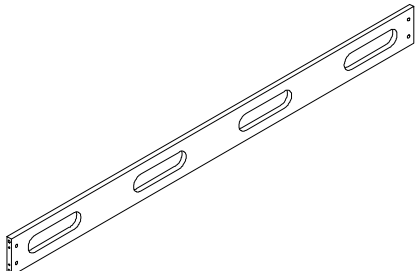
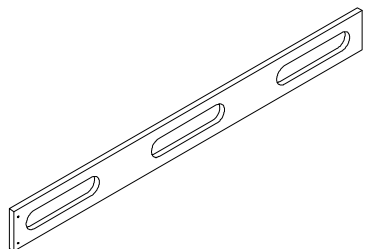
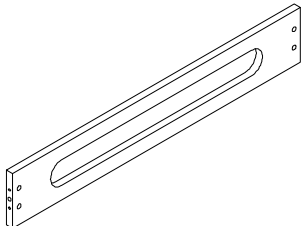
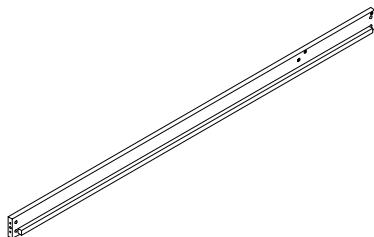
ASSEMBLERBEFEHL

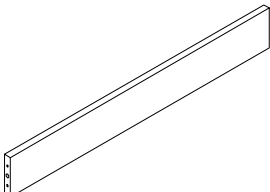
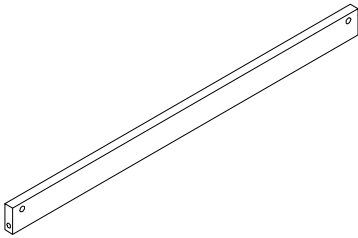
N622P306818W



<p>A</p>  <p>TOP GUARD RAIL BACK - 1 PC OBERSTE SCHUTZGITTER RÜCKSEITE - 1 STK BARRE DE SÉCURITÉ SUPÉRIEURE ARRIÈRE - 1 PCS</p>	<p>B</p>  <p>TOP GUARD RAIL FRONT - 1 PC OBERSTE SICHERUNGSLAISTE VORN - 1 STK GARDES DE RAIL AVANT - 1 PCS</p>	<p>C</p>  <p>TOP GUARD RAIL SIDE - 2 PCS OBERSTE SCHUTZLEITRAILSEITE - 2 STK GARDE-CORPS SUPÉRIEUR CÔTÉ - 2 PCS</p>
<p>D</p>  <p>TOP SIDE RAIL - 1 PC OBERSEITE BAHN - 1 STK RAIL DE CÔTÉ SUPÉRIEUR - 1 PCS</p>	<p>F</p>  <p>TOP VERTICAL RAIL - 1 PC OBERE VERTIKALE SCHIENE - 1 STK BARRE VERTICALE SUPÉRIEURE - 1 PCS</p>	<p>G</p>  <p>BOTTOM SIDE PANEL - 2 PCS UNTERE SEITENBLLENDE - 2 STK PANEL LATÉRAL INFÉRIEUR - 2 STK</p>
<p>H</p>  <p>TOP SIDE PANEL - 2 PCS OBERE SEITENWAND - 2 STK PANNEAU LATÉRAL SUPÉRIEUR - 2 PCS</p>	<p>I</p>  <p>LADDER SIDE (L/R) - 2 PCS LEITER SEITE LINKS/RECHTS - 2 STK CÔTÉ DE L'ÉCHELLE GAUCHE/DROIT - 2 PCS</p>	

ASSEMBLY INSTRUCTION

INSTRUCTIONS DE MONTAGE

ASSEMBLERBEFEHL

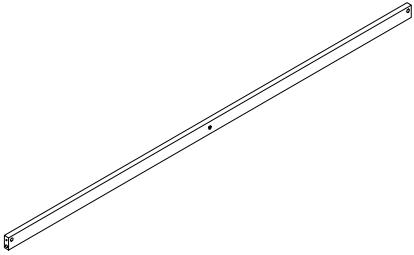
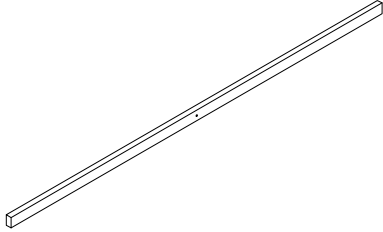
N622P306818W

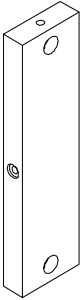
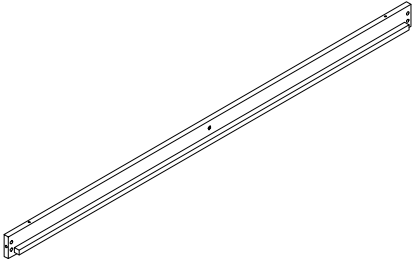
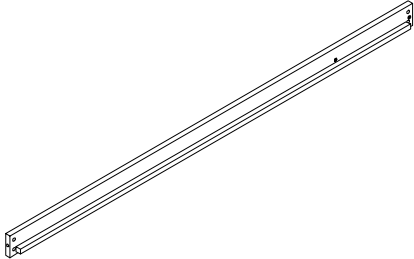
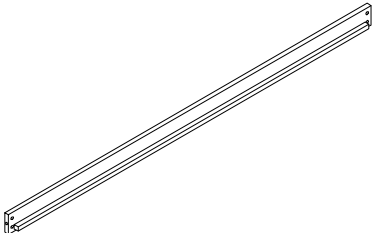
<p>J</p>  <p>BOTTOM BACK GUARD RAIL (A) - 1 PC UNTERE SICHERUNGSSTANGE RÜCKENLEISTE (A) - 1 STK RAIL ARRIÈRE DU GARDE-BAS (A) - 1 PCS</p>	<p>K</p>  <p>BOTTOM BACK GUARD RAIL (B) - 1 PC UNTERE SICHERUNGSSTANGE RÜCKENLEISTE (B) - 1 STK RAIL ARRIÈRE DU GARDE-BAS (B) - 1 PCS</p>	<p>L</p>  <p>BACK VERTICAL RAIL (A) - 1 PC HINTERE VERTIKALSTANGE (A) - 1 STK BARRE VERTICALE ARRIÈRE (A) - 1 PCS</p>
<p>M</p>  <p>BACK VERTICAL RAIL (B) - 2 PCS HINTERE VERTIKALSTANGE (B) - 2 STK BARRE VERTICALE ARRIÈRE (B) - 2 PCS</p>	<p>N</p>  <p>BOTTOM SIDE RAIL (A) - 1 PC UNTERE SEITE SCHALE (A) - 1 STK RAIL DE CÔTÉ INFÉRIEUR (A) - 1 PCS</p>	<p>O</p>  <p>BOTTOM SIDE RAIL (B) - 1 PC UNTERE SEITE SCHALE (B) - 1 STK RAIL DE CÔTÉ INFÉRIEUR (B) - 1 PCS</p>
<p>E</p>  <p>TOP SIDE RAIL - 1 PC OBERSEITE BAHN - 1 STK RAIL DE CÔTÉ SUPÉRIEUR - 1 PCS</p>		

ASSEMBLY INSTRUCTION

INSTRUCTIONS DE MONTAGE

ASSEMBLERBEFEHL

N622P306819W

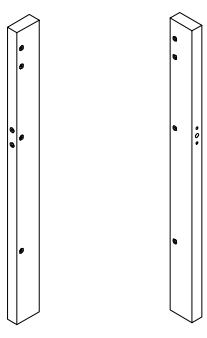
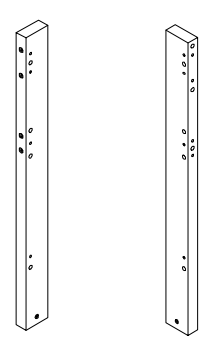
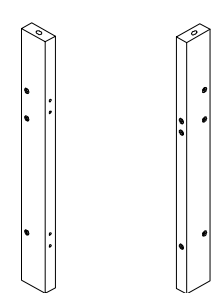
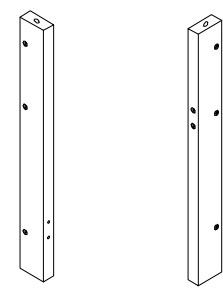
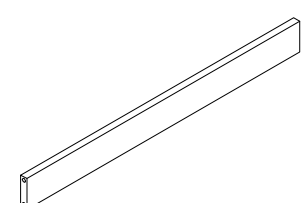
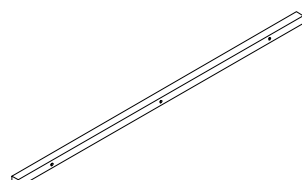
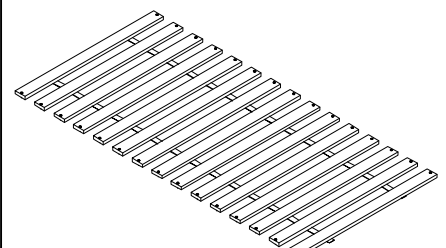
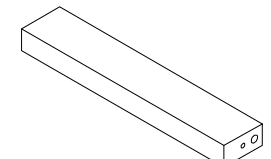





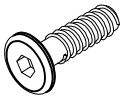
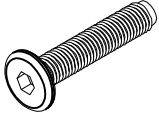

<p>Q</p>  <p style="text-align: center;">A B</p> <p style="text-align: center;">TOP POST - 2 PCS OBEN PAAL - 2 STK HAUT POTEAU - 2 PCS</p>	<p>R</p>  <p style="text-align: center;">A B</p> <p style="text-align: center;">TOP POST - 2 PCS OBEN PAAL - 2 STK HAUT POTEAU - 2 PCS</p>	<p>S</p>  <p style="text-align: center;">A B</p> <p style="text-align: center;">BOTTOM POST - 2 PCS UNTEN PAAL - 2 STK FOND POTEAU - 2 PCS</p>
<p>T</p>  <p style="text-align: center;">A B</p> <p style="text-align: center;">BOTTOM POST - 2 PCS UNTEN PAAL - 2 STK FOND POTEAU - 2 PCS</p>	<p>U</p>  <p style="text-align: center;">FRONT&BACK PANEL - 4 PCS VORDER- UND RÜCKPANELL - 4 STK PANEL AVANT ET ARRIÈRE - 4 PCS</p>	<p>V</p>  <p style="text-align: center;">PANEL SLAT SUPPORT - 4 PCS PANELGLEITSUPPORT - 4 STK SUPPORT DE GLISSIÈRE DE PANNEAU - 4 PCS</p>
<p>W</p>  <p style="text-align: center;">SLAT - 2SET LATTEN - 2SET LAMES - 2JEU</p>	<p>P</p>  <p style="text-align: center;">LADDER STEP - 4 PCS LADDERTREDEN - 4 STK MARCHEPIED - 4 PCS</p>	

ASSEMBLY INSTRUCTION

INSTRUCTIONS DE MONTAGE

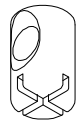
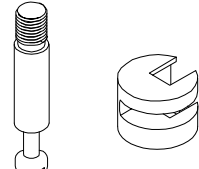
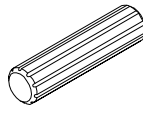

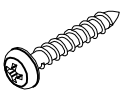
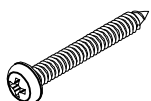

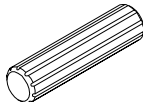
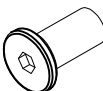
ASSEMBLERBEFEHL

N622P306819W

<p>1</p>  <p>JCBC M6 x 20 MM - 8 PCS JCBC M6 x 20 MM - 8 STK JCBC M6 x 20 MM - 8 PCS</p>	<p>2</p>  <p>JCBC M6 x 30 MM - 6 PCS JCBC M6 x 30 MM - 6 STK JCBC M6 x 30 MM - 6 PCS</p>	<p>3</p>  <p>JCBC M6 x 50 MM - 4 PCS JCBC M6 x 50 MM - 4 STK JCBC M6 x 50 MM - 4 PCS</p>
<p>4</p>  <p>JCBC M6 x 60 MM - 36 PCS JCBC M6 x 60 MM - 36 STK JCBC M6 x 60 MM - 36 PCS</p>	<p>5</p>  <p>JCBC M6 x 100 MM - 26 PCS JCBC M6 x 100 MM - 26 STK JCBC M6 x 100 MM - 26 PCS</p>	<p>6</p>  <p>BARREL NUT M6 x 15 MM - 66 PCS RINGMOER M6 X 15 MM - 66 STK ÉCROU À BARILLET M6 X 15 MM - 66 PCS</p>
<p>7</p>  <p>7A 7B</p> <p>MINIFIX 12M x 15MM - 4 PCS MINIFIX 12M x 15MM - 4 STK MINIFIX 12M x 15MM - 4 PCS</p>	<p>8</p>  <p>DOWEL M10 x 40 MM - 46 PCS PEN M10 X 40 MM - 46 STK GOUJON M10 X 40 MM - 46 PCS</p>	<p>9</p>  <p>METAL PIN - 4 PCS METALLPIN - 4 STK ÉPINGLES EN MÉTAL - 4 PCS</p>
<p>10</p>  <p>PANHEAD SCREW M4 x 25 MM - 60 PCS SCHROEF MET PANKOP M4 X 25 MM - 60 STK VIS À TÊTE CYLINDRIQUE M4 X 25 MM - 60 PCS</p>	<p>11</p>  <p>PANHEAD SCREW M4 x 32 MM - 12 PCS SCHROEF MET PANKOP M4 X 32 MM - 12 STK VIS À TÊTE CYLINDRIQUE M4 X 32 MM - 12 PCS</p>	<p>12</p>  <p>ALLEN KEY M4 - 1PC INBUSSLEUTEL M4 - 1STK CLÉ ALLEN M4 - 1PC</p>
<p>13</p>  <p>DOWEL M8 x 30 MM - 12 PCS PEN M8 X 30 MM - 12 STK GOUJON M8 X 30 MM - 12 PCS</p>	<p>14</p>  <p>JCN NUT 6M x 18 MM - 6 PCS JCN MUTTER 6M x 18 MM - 6 STK ÉCROU G-JCN 6M x 18 MM - 6 PCS</p>	

ASSEMBLY INSTRUCTION
INSTRUCTIONS DE MONTAGE
ASSEMBLERBEFEHL

STEP 1
ÉTAPE 1
SCHRITT 1

4		JCBC M6 x 60 MM JCBC M6 x 60 MM JCBC M6 x 60 MM	16
6		BARREL NUT M6 x 15 MM ÉCROU DE BARILLET M6 x 15 MM LAUFMUTTER M6 x 15 MM	16
8		DOWEL M10 x 40 MM CHEVILLE EN BOIS M10 x 40 MM HOLZ-DÜBEL M10 x 40 MM	12
11		PANHEAD SCREW M4 x 32 MM VIS PANHEAD M4 x 32 MM LINSENKOPF-SCHRAUBE M4 x 32 MM	6
13		DOWEL M8 x 30 MM CHEVILLE EN BOIS M8 x 30 MM HOLZ-DÜBEL M8 x 30 MM	4

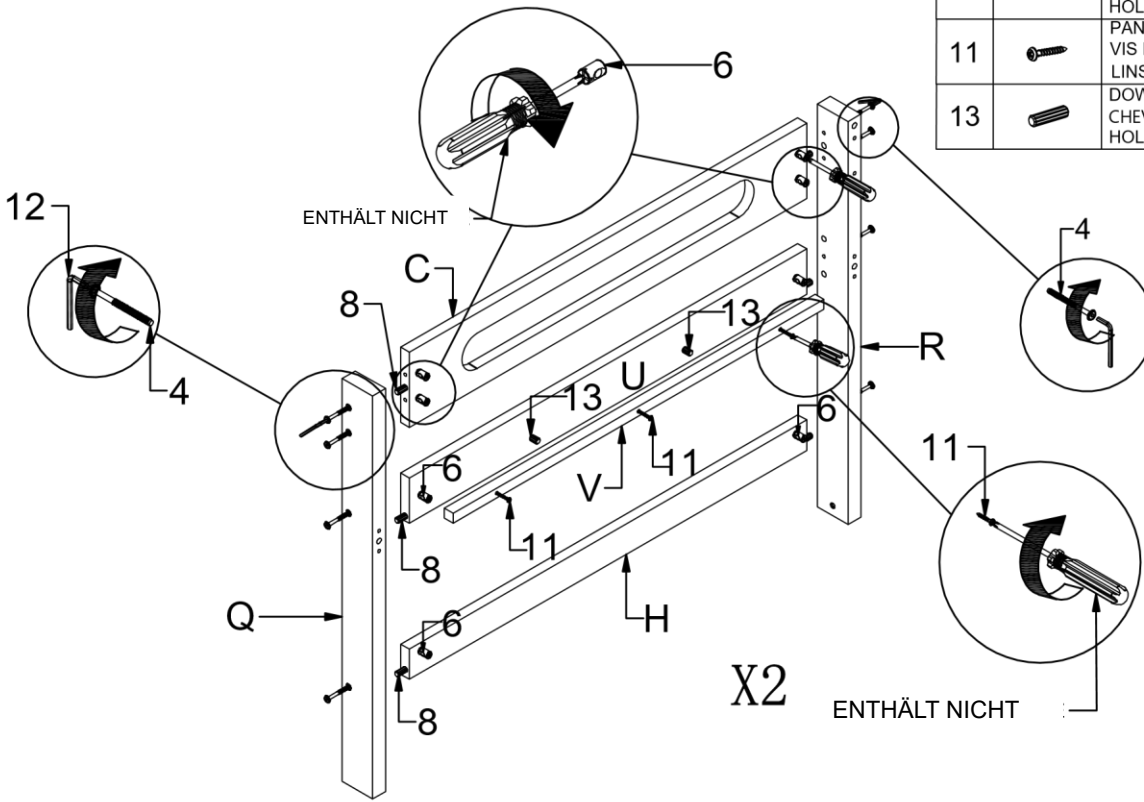



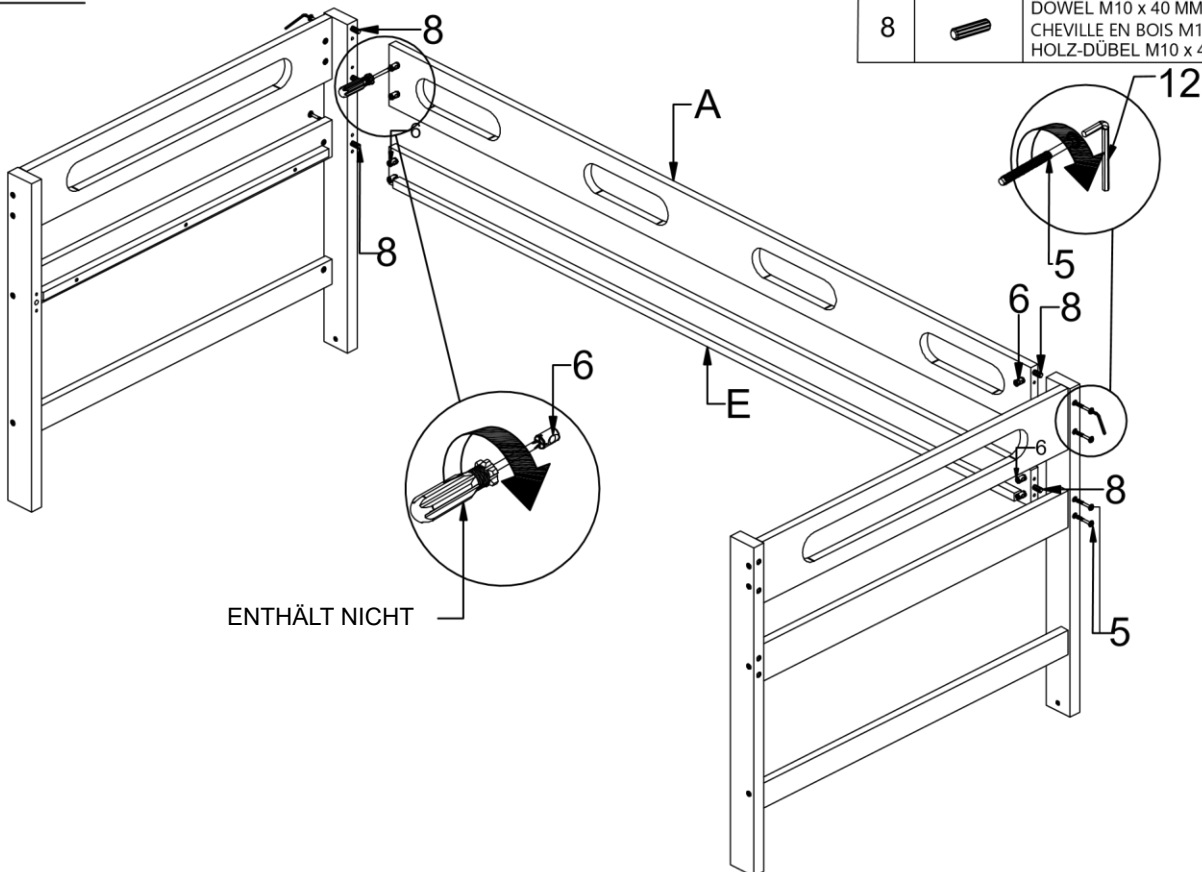

STEP 2
ÉTAPE 2
SCHRITT 2

5		JCBC M6 x 100 MM JCBC M6 x 100 MM JCBC M6 x 100 MM	8
6		BARREL NUT M6 x 15 MM ÉCROU DE BARILLET M6 x 15 MM LAUFMUTTER M6 x 15 MM	8
8		DOWEL M10 x 40 MM CHEVILLE EN BOIS M10 x 40 MM HOLZ-DÜBEL M10 x 40 MM	6



ASSEMBLY INSTRUCTION
INSTRUCTIONS DE MONTAGE
ASSEMBLERBEFEHL

STEP 3
ÉTAPE 3
SCHRITT 3

2		JCBC M6 x 30 MM JCBC M6 x 30 MM JCBC M6 x 30 MM	3
6		BARREL NUT M6 x 15 MM ÉCROU DE BARILLET M6 x 15 MM LAUFMUTTER M6 x 15 MM	6
14		JCN NUT 6M x 18 MM ECOUT JCN 6M x 18 MM JCN MUTTER 6M x 18 MM	3
8		DOWEL M10 x 40 MM CHEVILLE EN BOIS M10 x 40 MM HOLZ-DÜBEL M10 x 40 MM	4

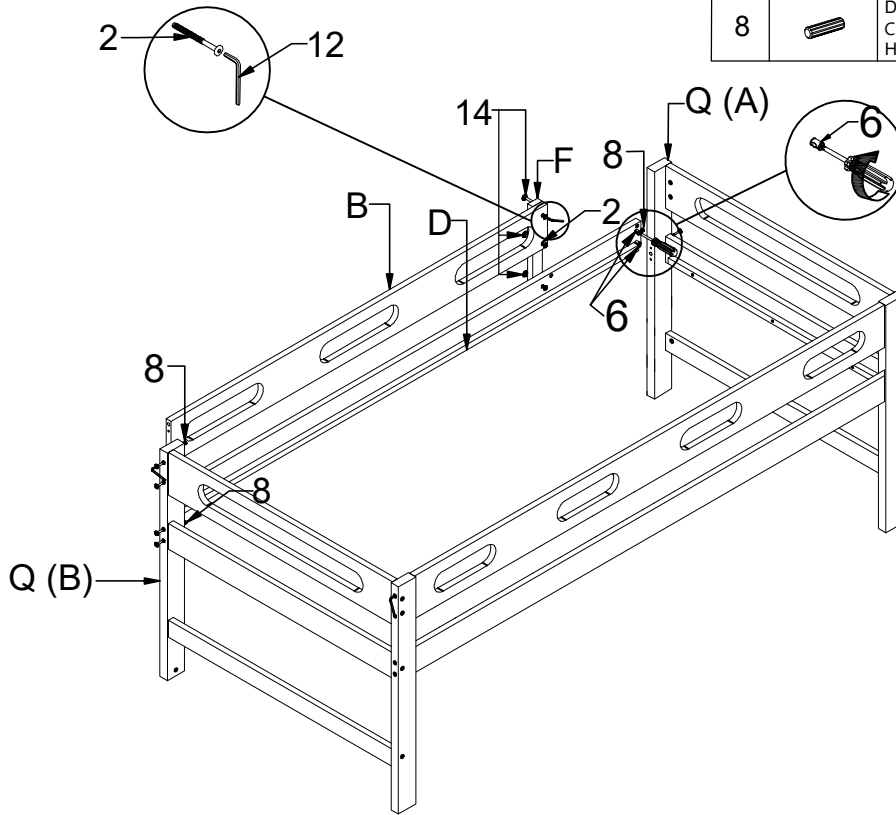



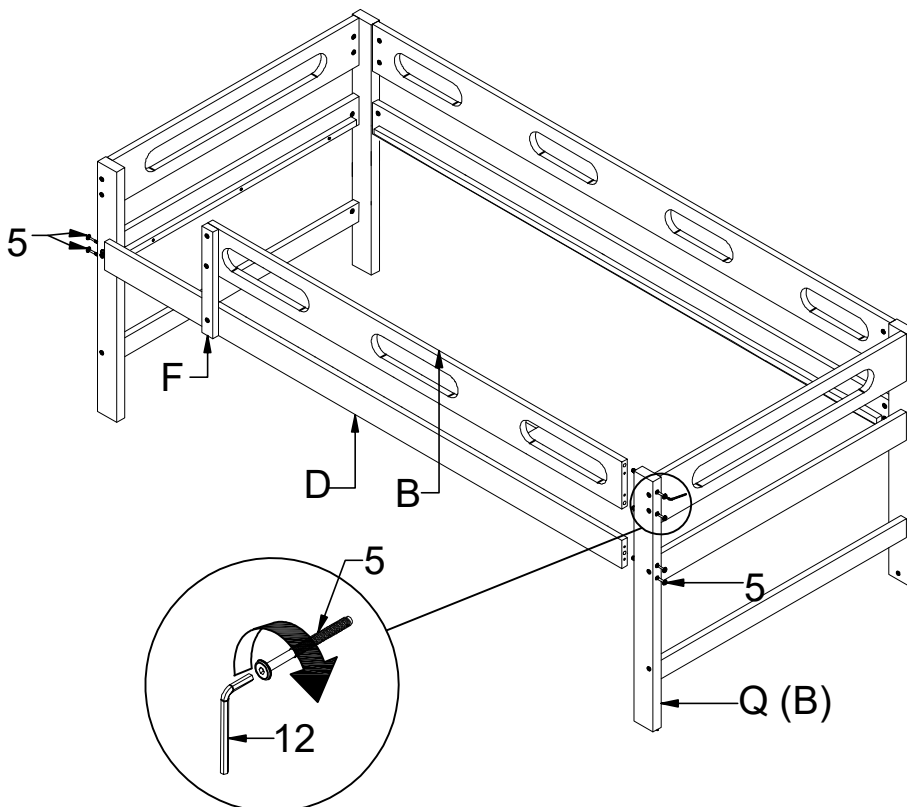

STEP 4
ÉTAPE 4
SCHRITT 4

5		JCBC M6 x 100 MM JCBC M6 x 100 MM JCBC M6 x 100 MM	6
---	---	--	---







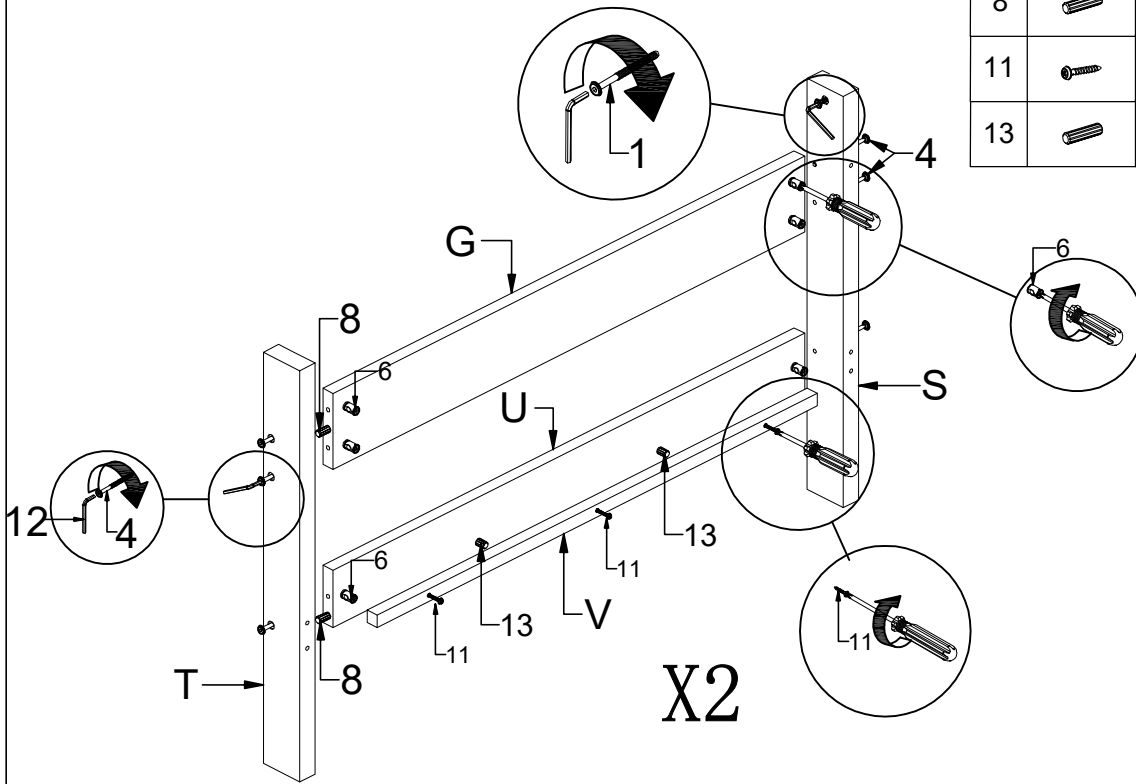

ASSEMBLY INSTRUCTION
INSTRUCTIONS DE MONTAGE
ASSEMBLERBEFEHL

STEP 5
ÉTAPE 5
SCHRITT 5

4		JCBC M6 x 60 MM JCBC M6 x 60 MM JCBC M6 x 60 MM	12
6		BARREL NUT M6 x 15 MM ÉCROU DE BARILLET M6 x 15 MM LAUFMUTTER M6 x 15 MM	12
8		DOWEL M10 x 40 MM CHEVILLE EN BOIS M10 x 40 MM HOLZ-DÜBEL M10 x 40 MM	8
11		PANHEAD SCREW M4 x 32 MM VIS PANHEAD M4 x 32 MM LINSENKOPF-SCHRAUBE M4 x 32 MM	6
13		DOWEL M8 x 30 MM CHEVILLE EN BOIS M8 x 30 MM HOLZ-DÜBEL M8 x 30 MM	4



STEP 6
ÉTAPE 6
SCHRITT 6

2		JCBC M6 x 30 MM JCBC M6 x 30 MM JCBC M6 x 30 MM	3
5		JCBC M6 x 100 MM JCBC M6 x 100 MM JCBC M6 x 100 MM	2
6		BARREL NUT M6 x 15 MM ÉCROU DE BARILLET M6 x 15 MM LAUFMUTTER M6 x 15 MM	8
7		MINI FIX 12MM x 15MM MINI FIX 12MM x 15MM MINI FIX 12MM x 15MM	4
8		DOWEL M10 x 40 MM CHEVILLE EN BOIS M10 x 40 MM HOLZ-DÜBEL M10 x 40 MM	6
13		DOWEL M8 x 30 MM CHEVILLE EN BOIS M8 x 30 MM HOLZ-DÜBEL M8 x 30 MM	4
14		JCN NUT 6M x 18 MM ECOUT JCN 6M x 18 MM JCN MUTTER 6M x 18 MM	3

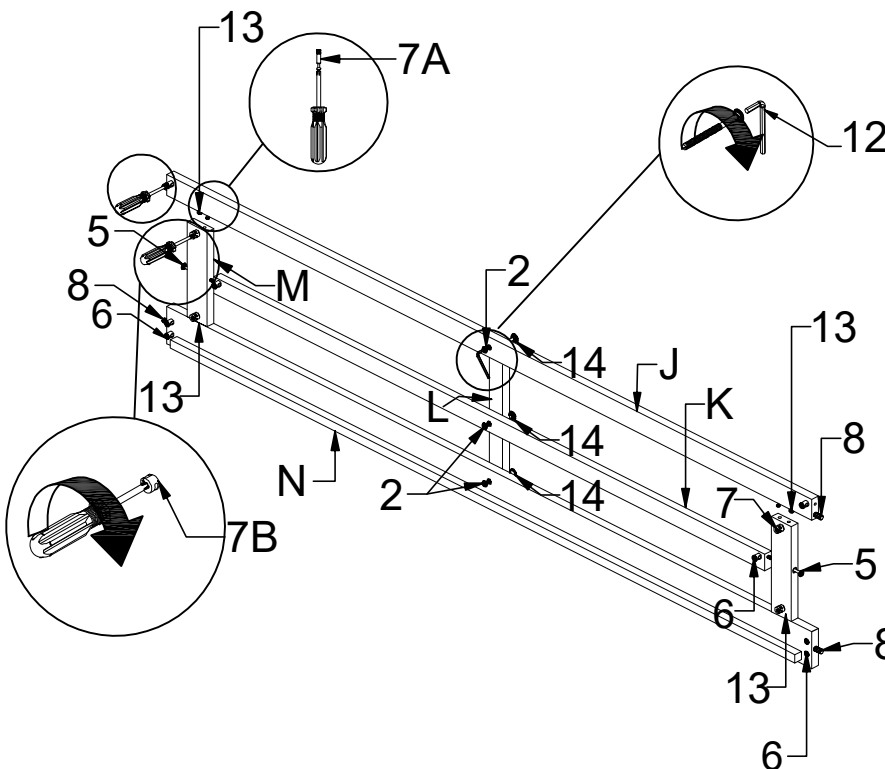

ASSEMBLY INSTRUCTION
INSTRUCTIONS DE MONTAGE
ASSEMBLERBEFEHL

STEP 7
ÉTAPE 7
SCHRITT 7

5		JCBC M6 x 100 MM JCBC M6 x 100 MM JCBC M6 x 100 MM	10
8		DOWEL M10 x 40 MM CHEVILLE EN BOIS M10 x 40 MM HOLZ-DÜBEL M10 x 40 MM	2
6		BARREL NUT M6 x 15 MM ÉCROU DE BARILLET M6 x 15 MM LAUFMUTTER M6 x 15 MM	4
9		METAL PIN GOUPILLE EN MÉTAL METALL-STIFT	4

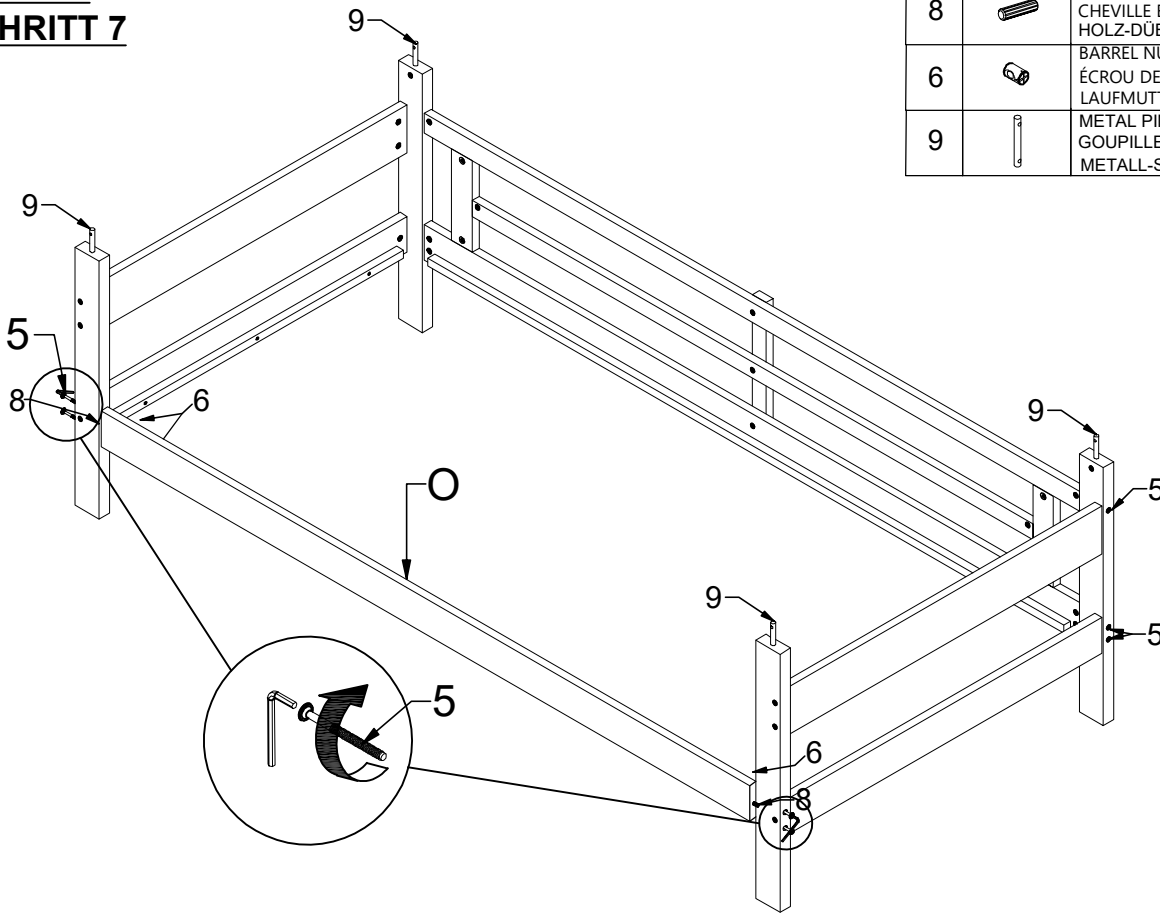

STEP 8
ÉTAPE 8
SCHRITT 8

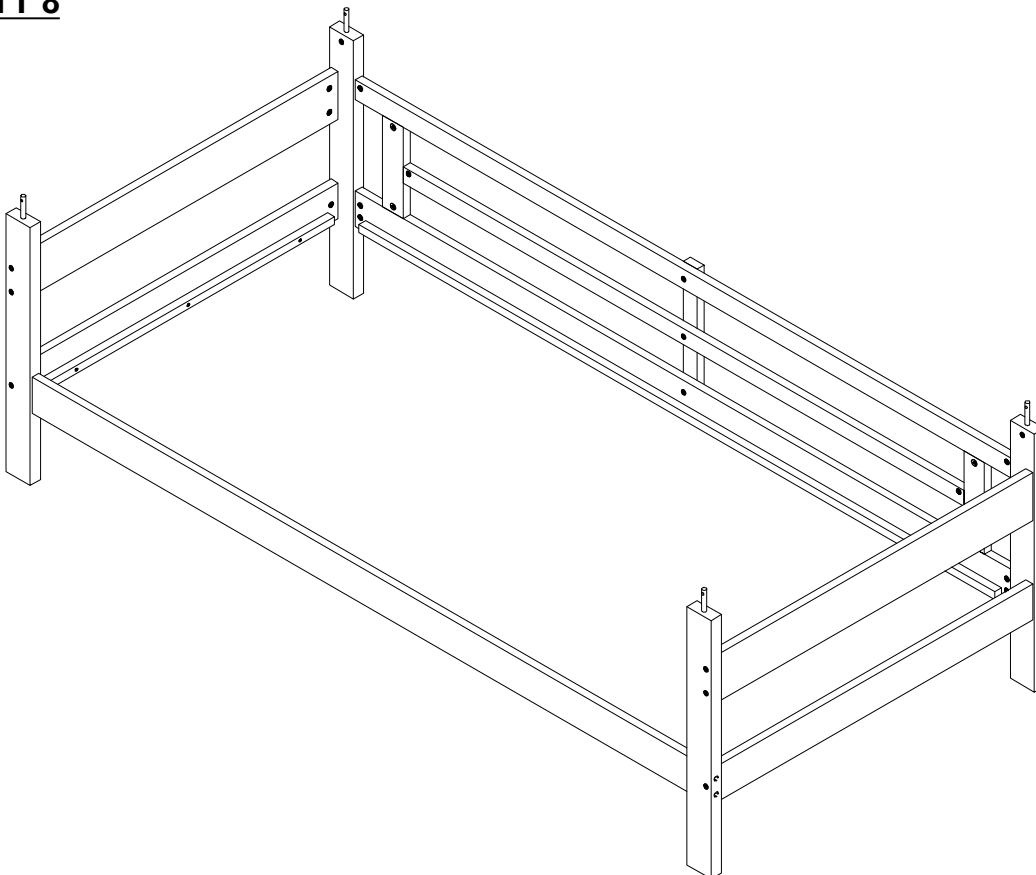



ASSEMBLY INSTRUCTION
INSTRUCTIONS DE MONTAGE
ASSEMBLERBEFEHL

STEP 9
ÉTAPE 9
SCHRITT 9

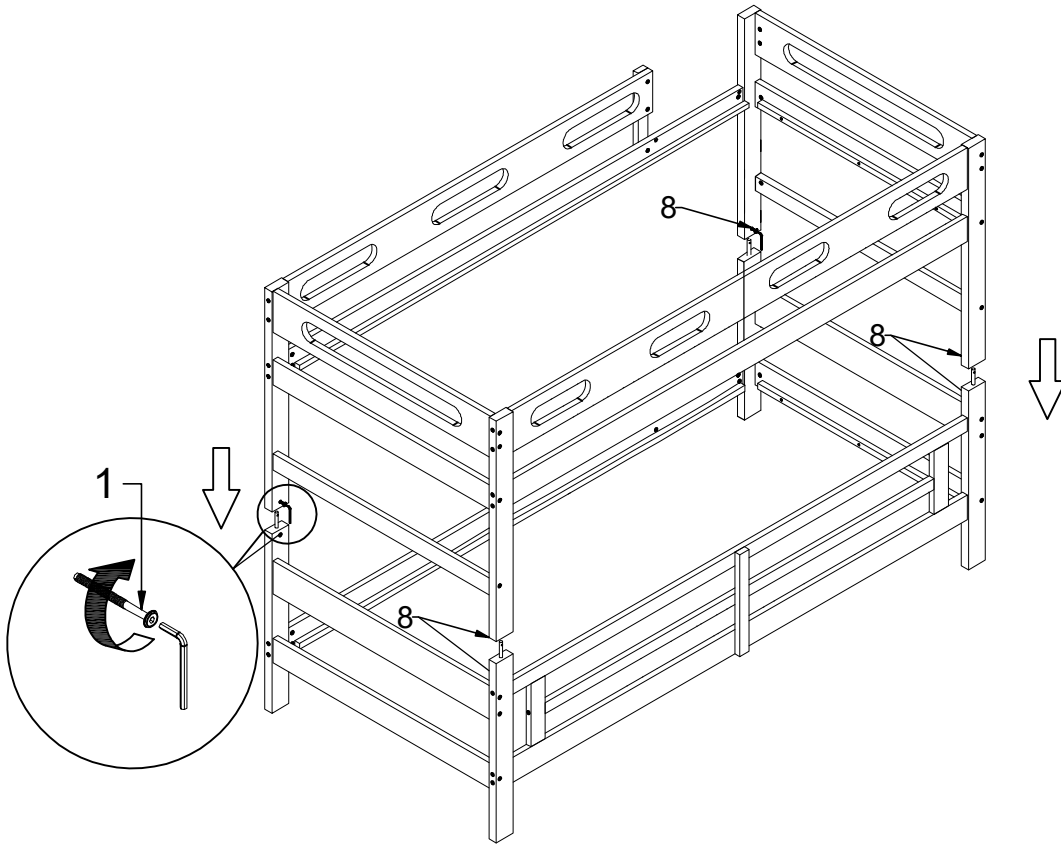
1		JCBC M6 x 20 MM JCBC M6 x 20 MM JCBC M6 x 20 MM	8
---	---	---	---



STEP 10
ÉTAPE 10
SCHRITT 10

6		BARREL NUT M6 x 15 MM ÉCROU DE BARILLET M6 x 15 MM LAUFMUTTER M6 x 15 MM	8
8		DOWEL M10 x 40 MM CHEVILLE EN BOIS M10 x 40 MM HOLZ-DÜBEL M10 x 40 MM	8
4		JCBC M6 x 60 MM JCBC M6 x 60 MM JCBC M6 x 60 MM	8

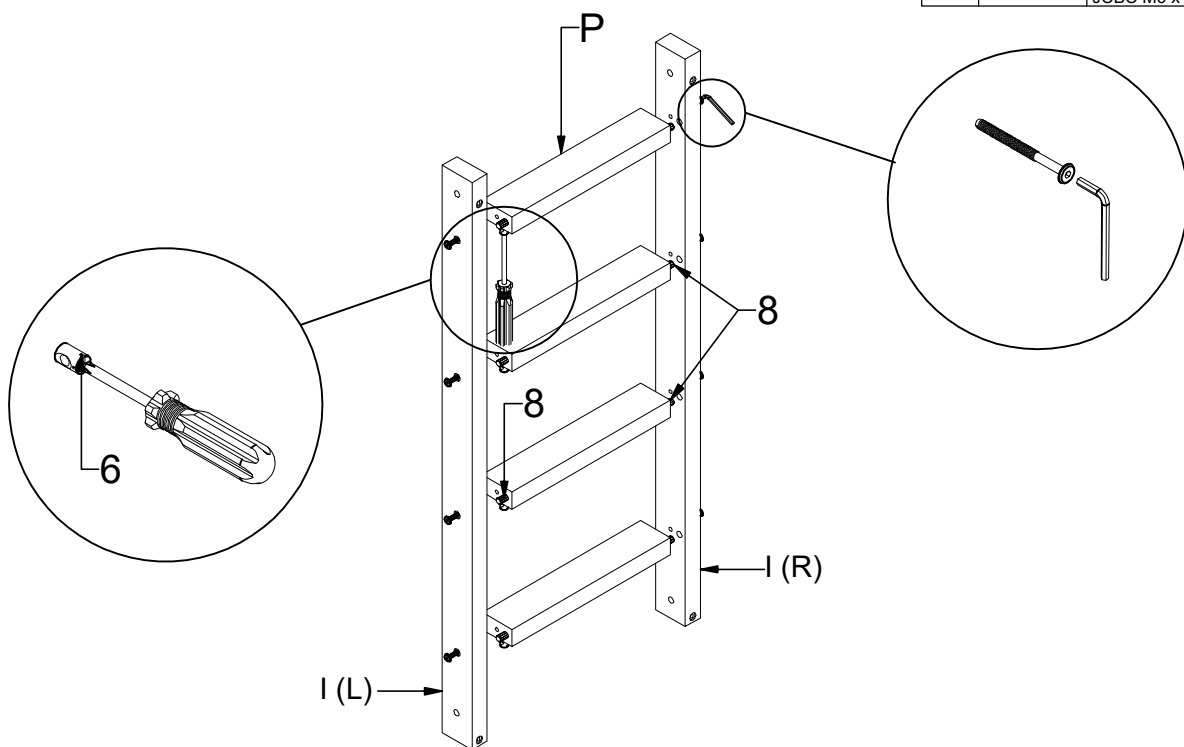

ASSEMBLY INSTRUCTION
INSTRUCTIONS DE MONTAGE
ASSEMBLERBEFEHL

STEP 11
ÉTAPE 11
SCHRITT 11

3		JCBC M6 x 50 MM JCBC M6 x 50 MM JCBC M6 x 50 MM	4
6		BARREL NUT M6 x 15 MM ÉCROU DE BARILLET M6 x 15 MM LAUFMUTTER M6 x 15 MM	4

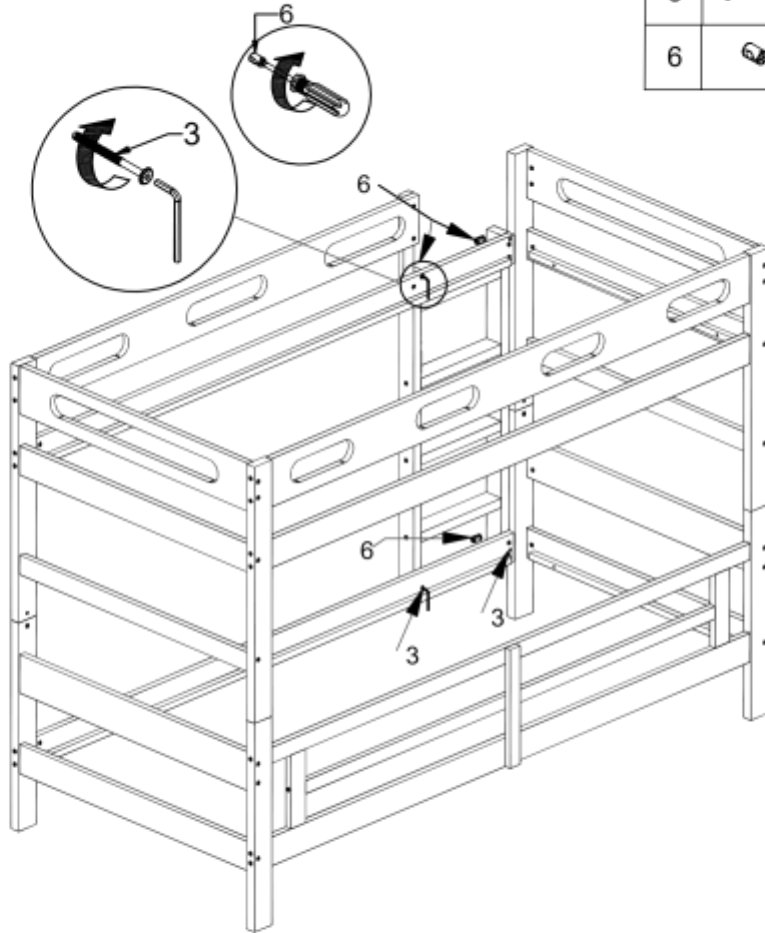

STEP 12
ÉTAPE 12
SCHRITT 12

10		PANHEAD SCREW M4 x 25 MM VIS PANHEAD M4 x 25 MM LINSKOPF-SCHRAUBE M4 x 25 MM	60
----	---	--	----

ENTHÄLT NICHT :

