

INSTALLATIONSANWEISUNG

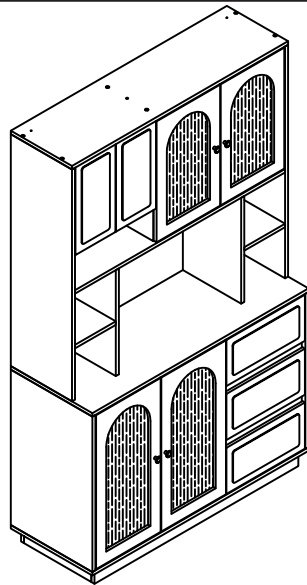

N621P469749

N621P469750

N621P469751



Our product will be delivered to you in 2 packages. The delivery times of these 2 packages may differ, please be patient and thank you for your understanding.

Unser Produkt wird Ihnen in 2 Paketen geliefert. Die Lieferzeiten dieser 2 Pakete können abweichen, bitte haben Sie etwas Geduld und vielen Dank für Ihr Verständnis.

Notre produit vous sera livré en 2 colis. Les délais de livraison de ces 2 colis peuvent différer, soyez patient et merci de votre compréhension.

EN Customer Service

Please read the instructions fully before assembly. These instructions include important information which could ensure correct assembly. We have been working on providing high quality products for

you. However, in the rare instance that your product is defective, missing parts or there are some issues, please don't hesitate to contact our customer service to submit parts requirements, assembly

suggestion, or warranty claims, and we will give the best solution as soon as possible. In order to solve the problem as quickly as possible, please provide the part number, quantity, and clearer picture of the defective part.

Installation Tips

1. Tighten all screws to 50% before fastening them.
2. Place the item on a flat surface to adjust it and ensure it remains stable.
3. Gradually tighten all screws with a tool.
4. If screws become loose during assembly, please loosen all other screws by 50% and continue the assembly process.
5. If the item is not stable, please loosen all screws, align on a flat surface, and tighten all screws again.
6. If one or more screws are misaligned during assembly, there is a possibility that the others are not aligned with the holes. Additionally, all holes are designed to be relatively larger to provide more room for adjusting the screws.

DE Kundenservice

Bitte lesen Sie die Anweisungen vollständig, bevor Sie mit der Montage beginnen. Diese Anweisungen enthalten wichtige Informationen, die eine korrekte Montage gewährleisten können. Wir arbeiten daran, qualitativ hochwertige Produkte für Sie bereitzustellen. Sollte Ihr Produkt jedoch im seltenen Fall defekt sein, Teile fehlen oder es Probleme gibt, zögern Sie bitte nicht, sich mit unserem Kundenservice in Verbindung zu setzen, um Teileanforderungen, Montagevorschläge oder Garantieansprüche zu übermitteln. Wir werden so schnell wie möglich die beste Lösung bieten. Um das Problem so schnell wie möglich zu lösen, geben Sie bitte die Teilenummer, Menge und ein klareres Bild des defekten Teils an.

Installationshinweise

1. Ziehen Sie alle Schrauben zu 50 % fest, bevor Sie sie befestigen.
2. Stellen Sie den Artikel auf eine ebene Fläche, um ihn einzustellen und sicherzustellen, dass er stabil bleibt.
3. Ziehen Sie alle Schrauben allmählich mit einem Werkzeug fest.
4. Wenn Schrauben während der Montage locker werden, lockern Sie bitte alle anderen Schrauben um 50 % und setzen Sie den Montageprozess fort
5. Wenn der Artikel nicht stabil ist, lockern Sie bitte alle Schrauben, richten Sie ihn auf einer ebenen Fläche aus und ziehen Sie alle Schrauben erneut fest.
6. Wenn bei der Montage eine oder mehrere Schrauben nicht ausgerichtet sind, besteht die Möglichkeit, dass die anderen nicht mit den Löchern ausgerichtet sind. Außerdem sind alle Löcher so konzipiert, dass sie relativ größer sind, um mehr Platz für die Einstellung der Schrauben zu bieten.

FR Service Client

Veillez lire attentivement les instructions avant l'assemblage. Ces instructions contiennent des informations importantes qui peuvent garantir un montage correct. Nous travaillons à fournir des produits de haute qualité pour vous. Cependant, dans le cas rare où votre produit est défectueux, des pièces sont manquantes ou s'il y a des problèmes, n'hésitez pas à contacter notre service client pour soumettre des demandes de pièces, des suggestions d'assemblage ou des réclamations de garantie, et nous vous fournirons la meilleure solution dès que possible. Afin de résoudre le problème le plus rapidement possible, veuillez fournir le numéro de pièce, la quantité et une photo plus claire de la pièce défectueuse.

Conseils d'Installation

1. Serrez toutes les vis à 50 % avant de les fixer.
2. lacez l'article sur une surface plane pour l'ajuster et assurez-vous qu'il reste stable.
3. Serrez progressivement toutes les vis avec un outil.
4. Si les vis se desserrent pendant l'assemblage, veuillez desserrer toutes les autres vis de 50 % et continuer le processus d'assemblage.
5. Si l'article n'est pas stable, veuillez desserrer toutes les vis, aligner sur une surface plane et resserrer toutes les vis à nouveau.
6. Si une ou plusieurs vis sont mal alignées pendant l'assemblage, il est possible que les autres ne soient pas alignées avec les trous. De plus, tous les trous sont conçus pour être relativement plus grands afin de fournir plus d'espace pour ajuster les vis.

ES Servicio al cliente

Lea las instrucciones por completo antes de ensamblar. Estas instrucciones incluyen información importante que puede garantizar un ensamblaje correcto. Hemos estado trabajando para brindarle productos de alta calidad. Sin embargo, en el caso poco frecuente de que su producto esté defectuoso, le falten piezas o haya algún problema, no dude en comunicarse con nuestro servicio al cliente para enviarnos sus requisitos de piezas, sugerencias de ensamblaje o reclamos de garantía, y le brindaremos la mejor solución lo antes posible. Para resolver el problema lo más rápido posible, proporcione el número de pieza, la cantidad y una imagen más clara de la pieza defectuosa.

Consejos de instalación

1. Apriete todos los tornillos al 50 % antes de apretarlos.
2. Coloque el artículo sobre una superficie plana para ajustarlo y asegurarse de que permanezca estable.
3. Apriete gradualmente todos los tornillos con una herramienta.
4. Si los tornillos se aflojan durante el ensamblaje, afloje todos los demás tornillos al 50 % y continúe con el proceso de ensamblaje.
5. Si el artículo no está estable, afloje todos los tornillos, alinéelo sobre una superficie plana y vuelva a apretarlos.
6. Si uno o más tornillos están desalineados durante el montaje, existe la posibilidad de que los demás no estén alineados con los orificios. Además, todos los orificios están diseñados para ser relativamente más grandes para proporcionar más espacio para ajustar los tornillos.

IT Servizio clienti

Si prega di leggere attentamente le istruzioni prima del montaggio. Queste istruzioni includono informazioni importanti che potrebbero garantire un montaggio corretto. Abbiamo lavorato per fornire prodotti di alta qualità per voi. Tuttavia, nel raro caso in cui il vostro prodotto sia difettoso, manchino parti o ci siano dei problemi, non esitate a contattare il nostro servizio clienti per inviare requisiti per le parti, suggerimenti per il montaggio o reclami in garanzia e vi daremo la migliore soluzione il prima possibile. Per risolvere il problema il più rapidamente possibile, vi preghiamo di fornire il numero di parte, la quantità e un'immagine più chiara della parte difettosa.

Suggerimenti per l'installazione

1. Serrare tutte le viti al 50% prima di fissarle.
2. Posizionare l'articolo su una superficie piana per regolarlo e assicurarsi che rimanga stabile.
3. Serrare gradualmente tutte le viti con uno strumento.
4. Se le viti si allentano durante il montaggio, allentare tutte le altre viti del 50% e continuare il processo di montaggio.
5. Se l'articolo non è stabile, allentare tutte le viti, allinearle su una superficie piana e stringere nuovamente tutte le viti.
6. Se una o più viti sono disallineate durante il montaggio, è possibile che le altre non siano allineate con i fori. Inoltre, tutti i fori sono progettati per essere relativamente più grandi per fornire più spazio per la regolazione delle viti.

NL Klantenservice

Lees de instructies volledig door voordat u ze monteert. Deze instructies bevatten belangrijke informatie die een correcte montage kan garanderen. We hebben eraan gewerkt om u producten van hoge kwaliteit te leveren. Mocht uw product echter in het zeldzame geval defect zijn, ontbreken er onderdelen of zijn er problemen, aarzel dan niet om contact op te nemen met onze klantenservice om onderdelenvereisten, montagesuggesties of garantieclaims in te dienen, en wij zullen u zo snel mogelijk de beste oplossing bieden. Om het probleem zo snel mogelijk op te lossen, dient u het onderdeelnummer, de hoeveelheid en een duidelijkere foto van het defecte onderdeel te verstrekken.

Installatietips

1. Draai alle schroeven tot 50% vast voordat u ze vastdraait.
2. Plaats het artikel op een vlak oppervlak om het af te stellen en ervoor te zorgen dat het stabiel blijft.
3. Draai alle schroeven geleidelijk vast met een gereedschap.
4. Als de schroeven losraken tijdens de montage, draai dan alle andere schroeven tot 50% los en ga door met het montageproces.
5. Als het item niet stabiel is, draai dan alle schroeven los, lijn ze uit op een vlak oppervlak en draai alle schroeven weer vast.
6. Als een of meer schroeven tijdens de montage niet goed uitgelijnd zijn, is er een kans dat de andere niet uitgelijnd zijn met de gaten. Bovendien zijn alle gaten relatief groter ontworpen om meer ruimte te bieden voor het aanpassen van de schroeven

SV Kundtjänst

Läs hela instruktionerna innan montering. Dessa instruktioner innehåller viktig information som kan säkerställa korrekt montering. Vi har arbetat med att tillhandahålla högkvalitativa produkter för du. Men i det sällsynta fall att din produkt är defekt, saknar delar eller det finns några problem, tveka inte att kontakta vår kundtjänst för att skicka in delarkrav, montering förslag eller garantianspråk, så ger vi den bästa lösningen så snart som möjligt. För att lösa problemet så snabbt som möjligt, vänligen ange artikelnummer, kvantitet och en tydligare bild av den defekta delen.

Installationstips

1. Dra åt alla skruvar till 50 % innan du fäster dem.
2. Placera föremålet på en plan yta för att justera det och se till att det förblir stabilt.
3. Dra åt alla skruvar gradvis med ett verktyg.
4. Om skruvar lossnar under monteringen, vänligen lossa alla andra skruvar med 50 % och fortsätt monteringsprocessen.
5. Om föremålet inte är stabilt, vänligen lossa alla skruvar, rikta in dem på en plan yta och dra åt alla skruvar igen.
6. Om en eller flera skruvar är felinriktade under monteringen, finns det en möjlighet att de andra inte är i linje med hålen. Dessutom är alla hål utformade för att vara relativt större för att ge mer utrymme för att justera skruvarna.

PL Obsługa klienta

Przed montażem należy dokładnie przeczytać instrukcję. Instrukcja zawiera ważne informacje, które mogą zapewnić prawidłowy montaż. Dokładamy wszelkich starań, aby zapewnić Tobie produkty wysokiej jakości. Jednak w rzadkich przypadkach, gdy produkt jest wadliwy, brakuje w nim części lub występują jakieś problemy, prosimy o kontakt z naszym działem obsługi klienta w celu zgłoszenia wymagań dotyczących części, sugestii dotyczących montażu lub roszczeń gwarancyjnych, a my przedstawimy najlepsze rozwiązanie tak szybko, jak to możliwe. Aby rozwiązać problem tak szybko, jak to możliwe, prosimy o podanie numeru części, ilości i wyraźniejsze zdjęcie wadliwej części.

Wskazówki dotyczące instalacji

1. Przed przykręceniem dokręć wszystkie śruby o 50%.
2. Umieść przedmiot na płaskiej powierzchni, aby go wyregulować i upewnić się, że pozostaje stabilny.
3. Stopniowo dokręcaj wszystkie śruby za pomocą narzędzia.
4. Jeśli śruby poluzują się podczas montażu, poluzuj wszystkie pozostałe śruby o 50% i kontynuuj proces montażu.
5. Jeśli przedmiot nie jest stabilny, poluzuj wszystkie śruby, ustaw na płaskiej powierzchni i ponownie dokręć wszystkie śruby.
6. Jeśli jedna lub więcej śrub jest źle ustawionych podczas montażu, istnieje możliwość, że pozostałe nie są ustawione w jednej linii z otworami. Ponadto wszystkie otwory są zaprojektowane tak, aby były stosunkowo większe, aby zapewnić więcej miejsca na regulację śrub.



[DE]

Warnung: Lesen Sie die Anleitung vor dem Zusammenbau bitte vollständig durch. Überprüfen Sie, ob Sie alle auf den Seiten aufgeführten Komponenten und Werkzeuge haben.

Warnung: Legen Sie alle Teile auf eine ebene Fläche. Legen Sie eine weiche Decke oder Ähnliches darunter, um sie vor Kratzern oder Flecken zu schützen. Vermeiden Sie es, Komponenten über den Boden zu ziehen oder zu schieben.

Warnung: Überprüfen Sie regelmäßig alle Beschläge und Befestigungen, um sicherzustellen, dass sie sicher sind und um Unfälle zu vermeiden. Wenn Teile fehlen, kaputt, beschädigt oder abgenutzt sind, verwenden Sie das Produkt nicht weiter, bis es mit vom Hersteller autorisierten Teilen repariert wurde.

Warnung: Lassen Sie Kinder nicht auf die Möbel klettern, da dies zum Umkippen und zu schweren Verletzungen führen kann. Bauen Sie die Möbel außerhalb der Reichweite von Kindern zusammen.

Warnung: Stellen Sie die Möbel nicht in die Nähe von Feuerquellen oder heißen Gegenständen, um Brandgefahr zu vermeiden.

Warnung: Reinigen Sie die Möbel mit einem feuchten Tuch oder Alkohol. Verwenden Sie keine Reinigungsmittel mit ätzenden Chemikalien.

Warnung: Dieses Produkt ist mit einer Kippschutzvorrichtung ausgestattet. Bitte installieren Sie diese Vorrichtung unbedingt, um unnötige Verletzungen durch Umkippen zu vermeiden.



[EN]

Warning: Please read instructions fully before starting assembly. Check you have all the components and tools listed on pages.

Warning: Please place all parts on a flat surface. Place a soft blanket or similar underneath to protect against scratches or stains. Avoid dragging or sliding components across the floor.

Warning: Regularly check all fittings and fastenings to ensure they are secure and to prevent accidents. If any parts are missing, broken, damaged, or worn, discontinue use of the product until repairs have been made using factory authorized parts.

Warning: Do not allow children to climb on the furniture as this may result in tipping and serious personal injury. Assemble the furniture away from the reach of children.

Warning: Do not place furniture close to fire sources or high-temperature objects to avoid the risk of fire.

Warning: Clean furniture with a damp cloth or alcohol, avoid using cleaning agents containing corrosive chemicals.

Warning: This product is equipped with an anti-tilt device. Please be sure to install this device to prevent unnecessary injuries caused by tipping.

[FR]

Avertissement : Veuillez lire entièrement les instructions avant de commencer l'assemblage. Vérifiez que vous disposez de tous les composants et outils répertoriés sur les pages.

Avertissement : Veuillez placer toutes les pièces sur une surface plane. Placez une couverture douce ou similaire en dessous pour les protéger des rayures ou des taches. Évitez de faire glisser les composants sur le sol.

Avertissement : Vérifiez régulièrement tous les raccords et fixations pour vous assurer qu'ils sont bien fixés et pour éviter les accidents. Si des pièces manquent, sont cassées, endommagées ou usées, cessez d'utiliser le produit jusqu'à ce que des réparations aient été effectuées à l'aide de pièces autorisées par l'usine.

Avertissement : Ne laissez pas les enfants grimper sur les meubles car cela pourrait entraîner un basculement et des blessures graves. Assemblez les meubles hors de portée des enfants.

Avertissement : Ne placez pas les meubles à proximité de sources de feu ou d'objets à haute température pour éviter tout risque d'incendie.

Avertissement : Nettoyez les meubles avec un chiffon humide ou de l'alcool, évitez d'utiliser des produits de nettoyage contenant des produits chimiques corrosifs.

Avertissement : Ce produit est équipé d'un dispositif anti-basculement. Assurez-vous d'installer ce dispositif pour éviter les blessures inutiles causées par un basculement.

[IT]

Attenzione: leggere attentamente le istruzioni prima di iniziare il montaggio. Verificare di avere tutti i componenti e gli strumenti elencati nelle pagine.

Attenzione: posizionare tutte le parti su una superficie piana. Posizionare una coperta morbida o simile sotto per proteggere da graffi o macchie. Evitare di trascinare o far scivolare i componenti sul pavimento.

Attenzione: controllare regolarmente tutti i raccordi e i dispositivi di fissaggio per assicurarsi che siano sicuri e per prevenire incidenti. Se alcune parti sono mancanti, rotte, danneggiate o usurate, interrompere l'uso del prodotto fino a quando non siano state eseguite le riparazioni utilizzando parti autorizzate dalla fabbrica.

Attenzione: non consentire ai bambini di arrampicarsi sui mobili poiché ciò potrebbe causare ribaltamenti e gravi lesioni personali. Montare i mobili lontano dalla portata dei bambini.

Attenzione: non posizionare i mobili vicino a fonti di fuoco o oggetti ad alta temperatura per evitare il rischio di incendio.



Attenzione: pulire i mobili con un panno umido o alcol, evitare di utilizzare detergenti contenenti sostanze chimiche corrosive.

Attenzione: questo prodotto è dotato di un dispositivo antiribaltamento. Assicurarsi di installare questo dispositivo per prevenire lesioni inutili causate dal ribaltamento.

[ES]

Advertencia: Lea las instrucciones completamente antes de comenzar el montaje. Compruebe que tiene todos los componentes y herramientas que se enumeran en las páginas.

Advertencia: Coloque todas las piezas sobre una superficie plana. Coloque una manta suave o algo similar debajo para protegerlas de rayones o manchas. Evite arrastrar o deslizar los componentes por el piso.

Advertencia: Verifique regularmente todos los accesorios y fijaciones para asegurarse de que estén seguros y evitar accidentes. Si falta alguna pieza, está rota, dañada o desgastada, deje de usar el producto hasta que se hayan realizado las reparaciones con piezas autorizadas de fábrica.

Advertencia: No permita que los niños se suban a los muebles, ya que esto puede provocar que se vuelquen y lesiones personales graves. Monte los muebles fuera del alcance de los niños.

Advertencia: No coloque los muebles cerca de fuentes de fuego u objetos de alta temperatura para evitar el riesgo de incendio.

Advertencia: Limpie los muebles con un paño húmedo o alcohol, evite usar agentes de limpieza que contengan químicos corrosivos.

Advertencia: Este producto está equipado con un dispositivo antivuelco. Asegúrese de instalar este dispositivo para evitar lesiones innecesarias causadas por vuelcos.

Importeur	Decobus Handel GmbH		
Adresse	Innungsstraße 9, 21244 Buchholz, Deutschland		
URL	https://www.decobusgroup.de		
Hersteller	CAOXIAN MU SITE CRAFTS CO., LTD		
Adresse	NORTH OF THE MIDDLE OF YALUJIANG ROAD, QINGHE SUBDISTRICT OFFICE, CAO COUNTY, HEZE CITY, SHANDONG PROVINCE, CHINA		
Email /URL	MST5@CXMSTGY.COM		
Partienummer	N621P469749; N621P469750; N621P469751		
Hergestellt in	HERGESTELLT IN CHINA		
<table border="1"><tr><td>EC</td><td>REP</td></tr></table>	EC	REP	Decobus Handel GmbH Innungsstraße 9, 21244 Buchholz, Deutschland https://www.decobusgroup.de
EC	REP		

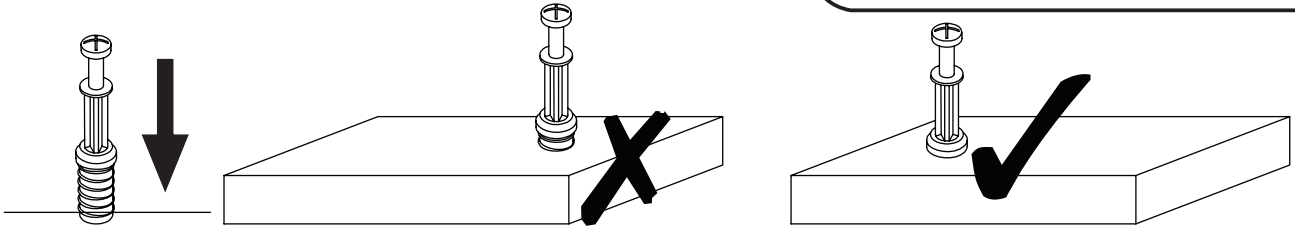

EN_QUICKFIT: Tighten quickfit until shoulder is flush with panel. Do not overtighten or undertighten.

FR_RACCORD RAPIDE: Faites serrer le raccord rapide jusqu'à ce que l'épaulement soit parfaitement encastré dans le panneau. Il ne faut ni trop serrer ni insuffisamment serrer.

ES_QUICKFIT: Apriete quickfit hasta que el hombro se descargue con el panel. NO lo sobreapriete ni lo apriete poco.

DE_QUICKFIT: Ziehen Sie den Quickfit fest, bis die Schulter mit der Platte bündig ist. Bitte nicht zu fest oder zu schwach anziehen.

IT_MONTAGGIO RAPIDO: Stringere il montaggio rapido fino a quando la spalla è a filo con il pannello, non stringere troppo o troppo poco.

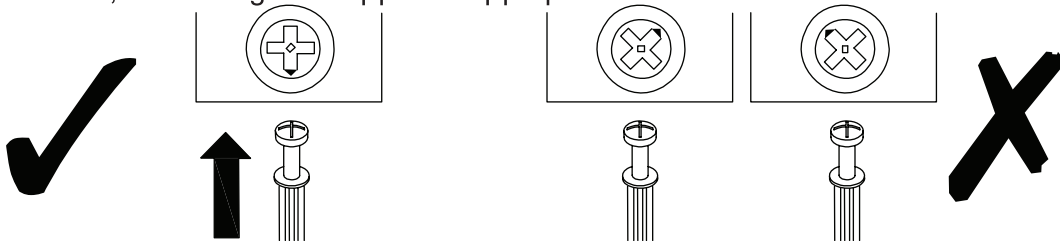

EN_CAM LOCK: When fitting cam lock, ensure starting position is correct before you insert connecting quickfit.

FR_SERRURE BATTEUSE: Avant d'insérer la serrure batteuse, veillez à la bonne orientation avant d'insérer le raccord rapide.

ES_CIERRE DE LA CÁMARA: Cuando instale el cierre de la cámara, asegúrese de que la posición de inicio es correcta antes de que inserte el quickfit conector.

DE_CAM-LOCK: Achten Sie bei der Montage des Cam-Locks auf die richtige Ausgangsposition, bevor Sie den Quickfit einsetzen.

IT_BLOCCAGGIO A CAMMA: Quando si monta il bloccaggio a camma, assicurarsi che la posizione iniziale sia corretta prima di inserire il montaggio rapido di collegamento.

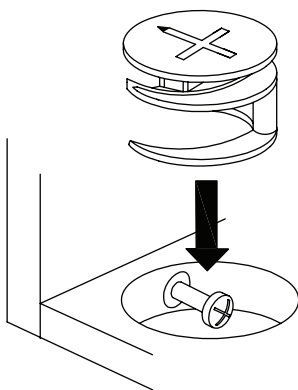

EN_Quickfit head should be in the centre of the cam lock when the two panels are joined.

Cam lock should be inserted before quickfit.

FR_Lorsque les deux panneaux sont assemblés, la tête du raccord rapide doit reposer au centre de la serrure batteuse. Il faut insérer la serrure batteuse avant le raccord rapide.

ES_El cabezal del quickfit debe estar en el centro del cierre de la cámara cuando se unan los dos paneles.

Se debe insertar el cierre de la cámara antes que el quickfit.

DE_Der Quickfit-Kopf sollte sich in der Mitte des Cam-Locks befinden, wenn die beiden Platten zusammengefügt sind.

Der Cam-Lock sollte vor dem Quickfit eingesetzt werden.

IT_La testa del montaggio rapido deve trovarsi al centro del bloccaggio a camma quando i due pannelli sono uniti.

Il Bloccaggio a Camma deve essere inserito prima del montaggio rapido.

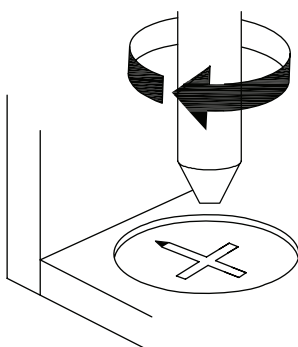

EN_Turn cam lock clockwise to tighten.

FR_Faites tourner la serrure batteuse dans le sens des aiguilles d'une montre pour la resserrer.

ES_Gire el cierre de la cámara en sentido horario para apretarlo.

DE_Drehen Sie den Cam-Lock im Uhrzeigersinn, um ihn festzuziehen.





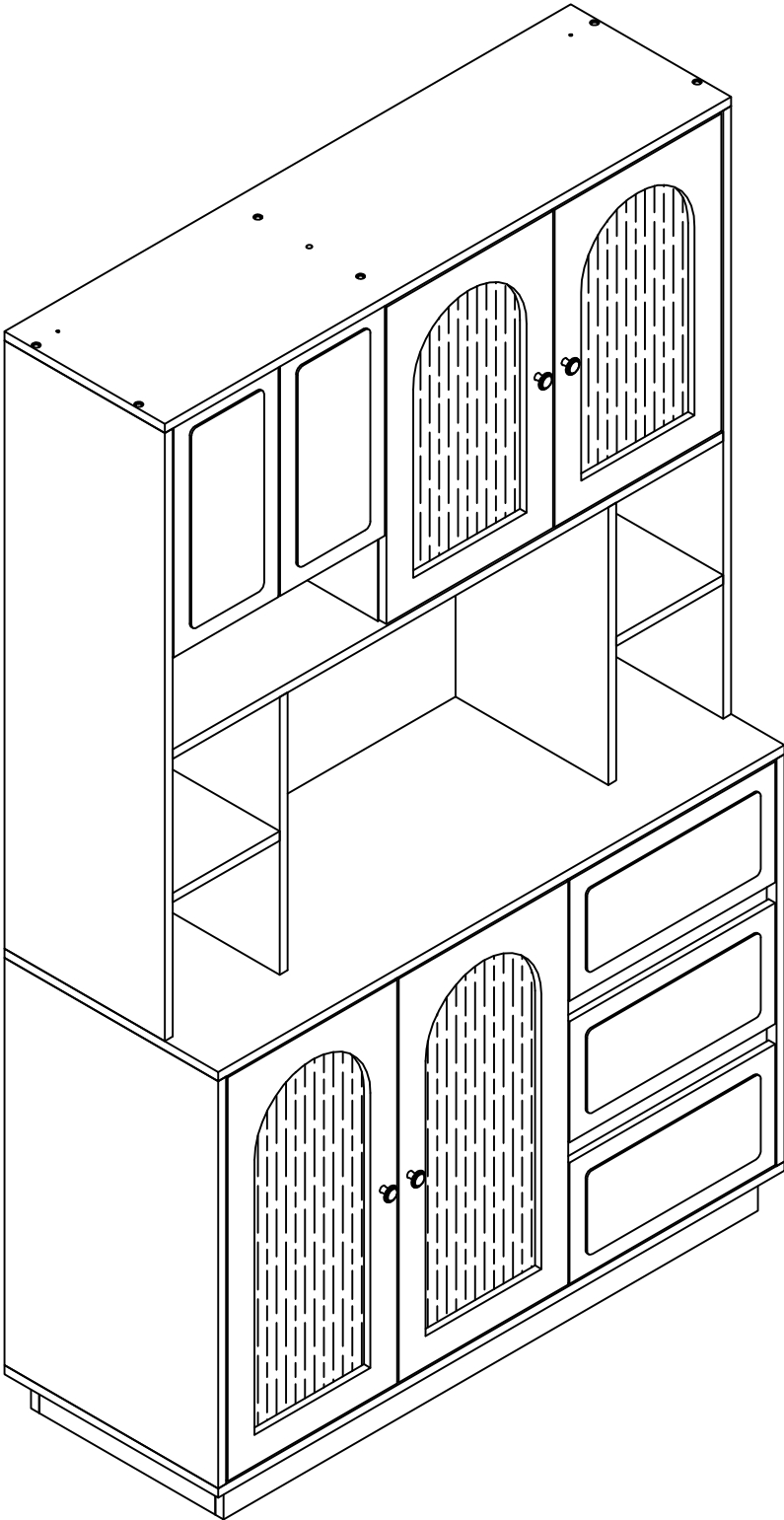

IT_Ruotare il bloccaggio a camma in senso orario per stringere.

N621P469749 N621P469750 N621P469751

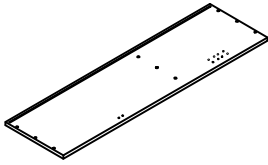
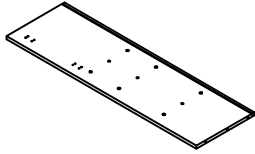
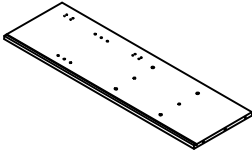
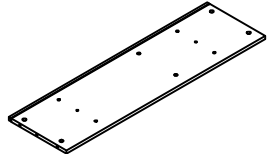

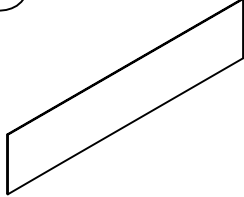

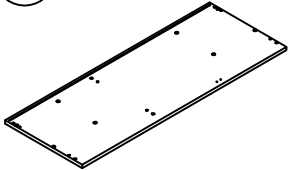
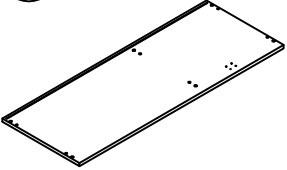
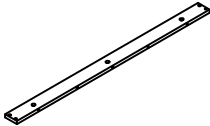
Parts List

N621P469749

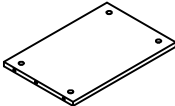
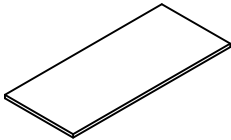
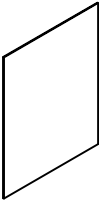
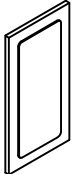
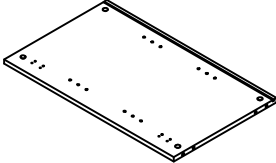
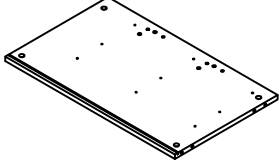
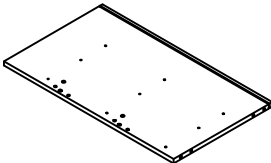
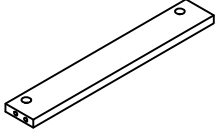
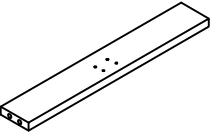
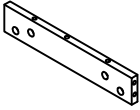

<p>① x1</p> 	<p>② x1</p> 	<p>③ x1</p> 	<p>⑧ x1</p> 
<p>⑭ x1</p> 	<p>⑮ x2</p> 	<p>⑯ x1</p> 	<p>⑳ x1</p> 
<p>⑳ x1</p> 	<p>㉓ x2</p> 	<p>㉗ x1</p> 	

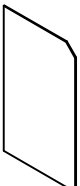
N621P469750

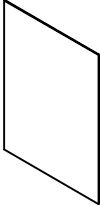
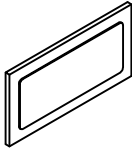
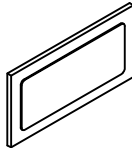
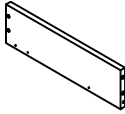
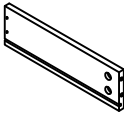

<p>⑦ x1</p> 	<p>⑨ x1</p> 	<p>⑪ x1</p> 	<p>⑰ x2</p> 
<p>㉑ x1</p> 	<p>㉒ x1</p> 	<p>㉓ x1</p> 	<p>㉔ x2</p> 
<p>㉕ x2</p> 	<p>㉘ x2</p> 	<p>㉚ x1</p> 	<p>㉛ x1</p> 

Parts List

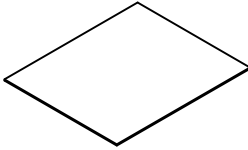
N621P469750



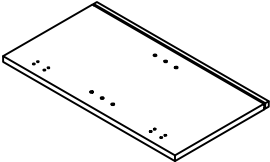
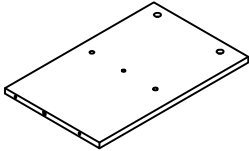
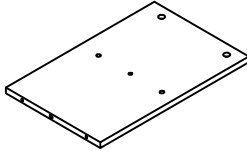
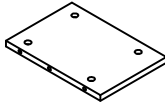

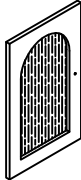
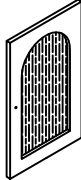
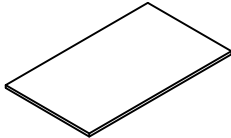
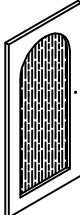
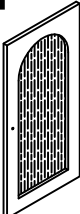

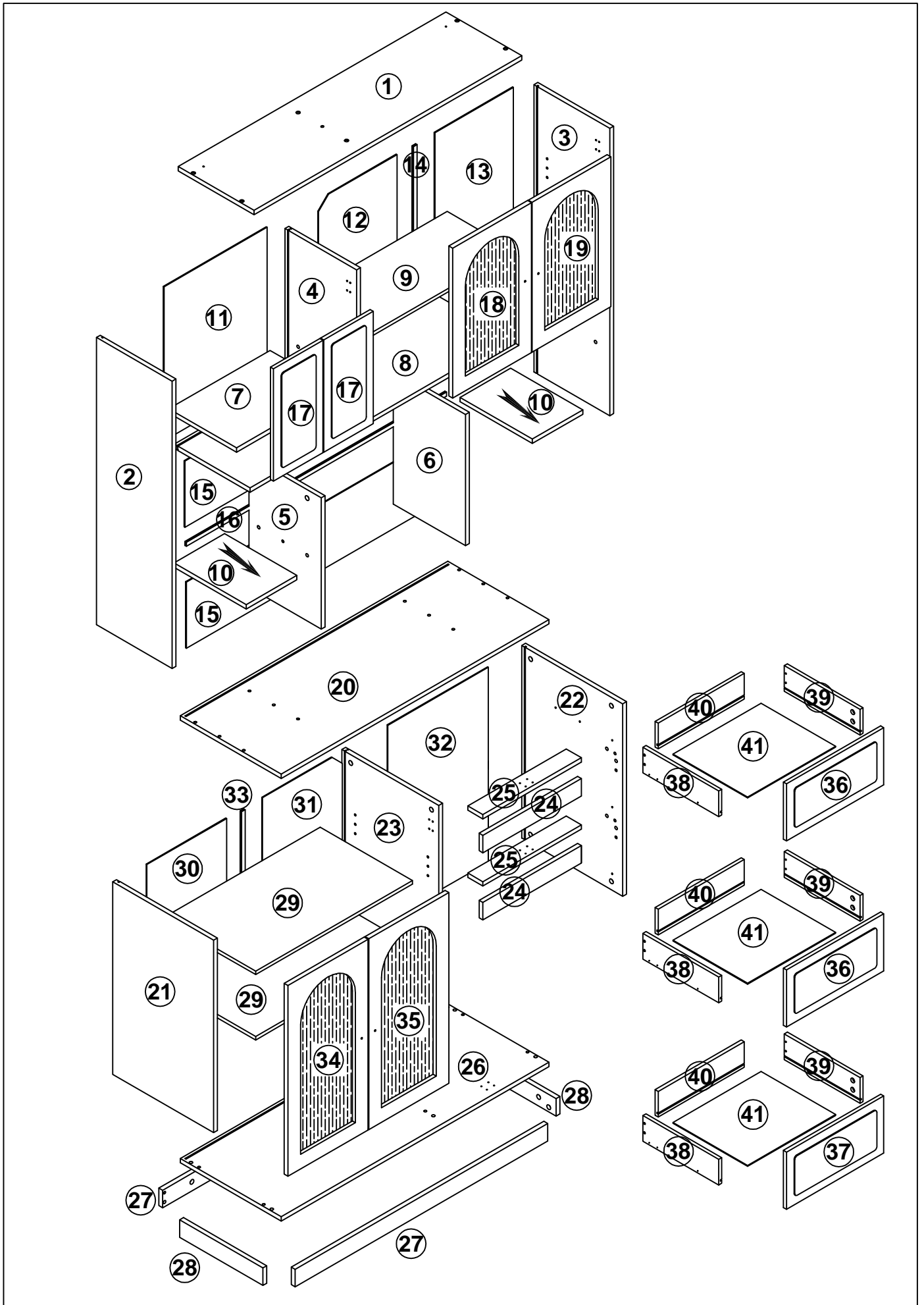



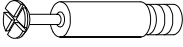

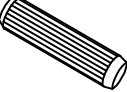





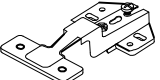
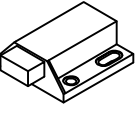

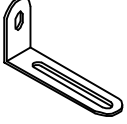
32 x1 	36 x2 	37 x1 	38 x3 
39 x3 	40 x3 	41 x3 	

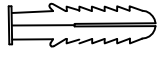
N621P469751

4 x1 	5 x1 	6 x1 	10 x2 
12 x1 	13 x1 	18 x1 	19 x1 
29 x2 	34 x1 	35 x1 	

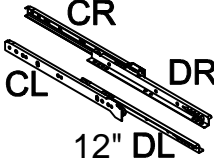

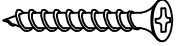
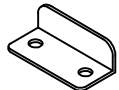
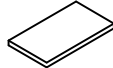
N621P469751

(A) 66+1 pcs  $\varnothing 15 \times 9 \text{mm}$	(B) 66+1 pcs  $\varnothing 6 \times 35 \text{mm}$	(C) 48+1 pcs  $\varnothing 8 \times 30 \text{mm}$	(D) 16+1 pcs  $\varnothing 7 \times 50 \text{mm}$	(E) 1 pc  M4
(F) 4 pcs  $\varnothing 28 \text{mm}$	(G) 4+1 pcs  M4*20mm	(H) 12+1 pcs  $\varnothing 6 \times 17 \text{mm}$	(I) 4 pcs  $\varnothing 26 \text{mm}$	(J) 8 pcs  $\varnothing 26 \text{mm}$
(K) 5 pcs 	(L) 5 pcs 	(M) 2 pcs 	(N) 2 pcs  $\varnothing 4 \times 40 \text{mm}$	(O) 2 pcs  $\varnothing 8 \times 35 \text{mm}$
(P) 1 pc 	(Q) 6 pcs 	(R) 26+1 pcs 	(S) 66 pcs  $\varnothing 20 \text{mm}$	(T) 3 pcs CR  CL DR 12" DL
(U) 169+2 pcs  $\varnothing 3 \times 12 \text{mm}$	(V) 12+1 pcs  $\varnothing 4 \times 25 \text{mm}$	(W) 2 pcs 	(X) 6+1 pcs  $30 \times 15 \times 3 \text{mm}$	(Y) 2 pcs  $\varnothing 4 \times 15 \text{mm}$

DE

Vor dem Einbau die Schrauben in die Löcher stecken und festziehen, aber nicht bis 100%, 70% bis 80% anziehen reicht aus. Schließlich, nachdem alle Schrauben installiert sind, ziehen Sie alle Schrauben auf 100%. Wenn Sie auf diese Probleme stoßen, wie z. B. Fehlausrichtung der Löcher oder Unfähigkeit, bestimmte Teile zu installieren, überprüfen Sie bitte, ob die Schrauben korrekt verwendet werden und passen Sie die Dichtigkeit der Schrauben an.

UK

Before installation, insert the screws into the holes and tighten them, but do not tighten them to 100%, 70% to 80% is sufficient. Finally, after all screws are installed, tighten all screws to 100%. If you encounter these issues, such as if the holes cannot be aligned or some parts cannot be installed, please check if the screws are used correctly and adjust the tightness of the screws.

FR

Insérer la vis dans le trou avant la fin de l'assemblage, serrer la vis, mais ne pas serrer à 100%, 70% ~ 80% est correct. Enfin, une fois que toutes les vis sont bien serrées, toutes les vis sont serrées à 100%. Si vous rencontrez ces problèmes, par exemple si les trous ne sont pas alignés ou si certaines pièces ne peuvent pas être montées, vérifiez que les vis sont utilisées correctement et ajustez leur serrage.

1.

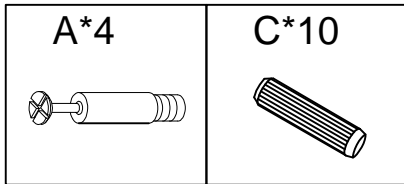
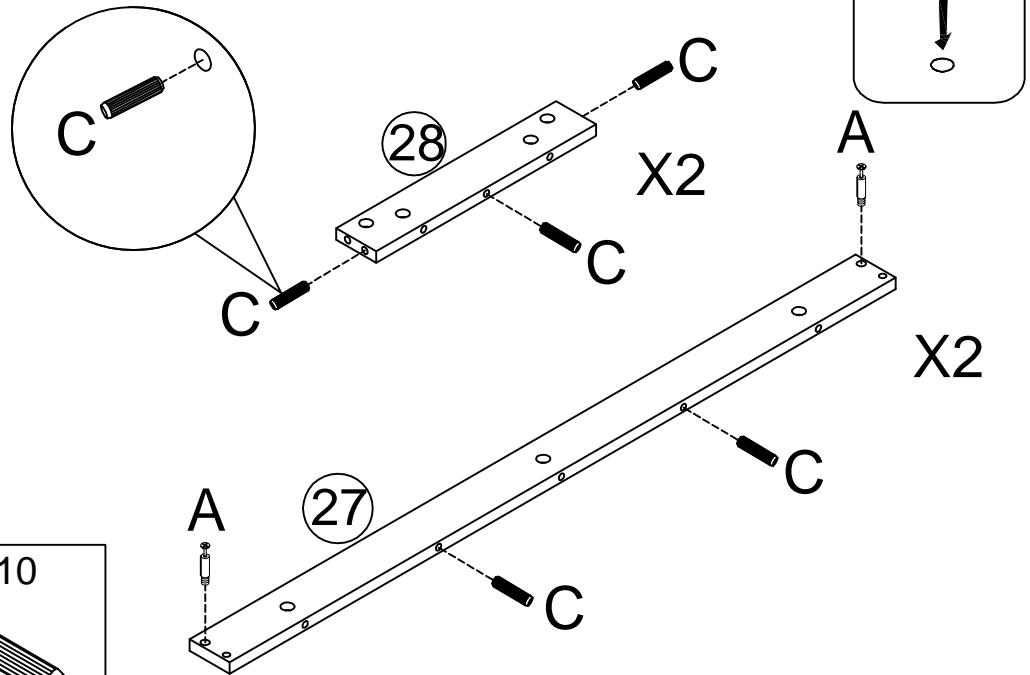

2.

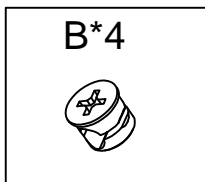
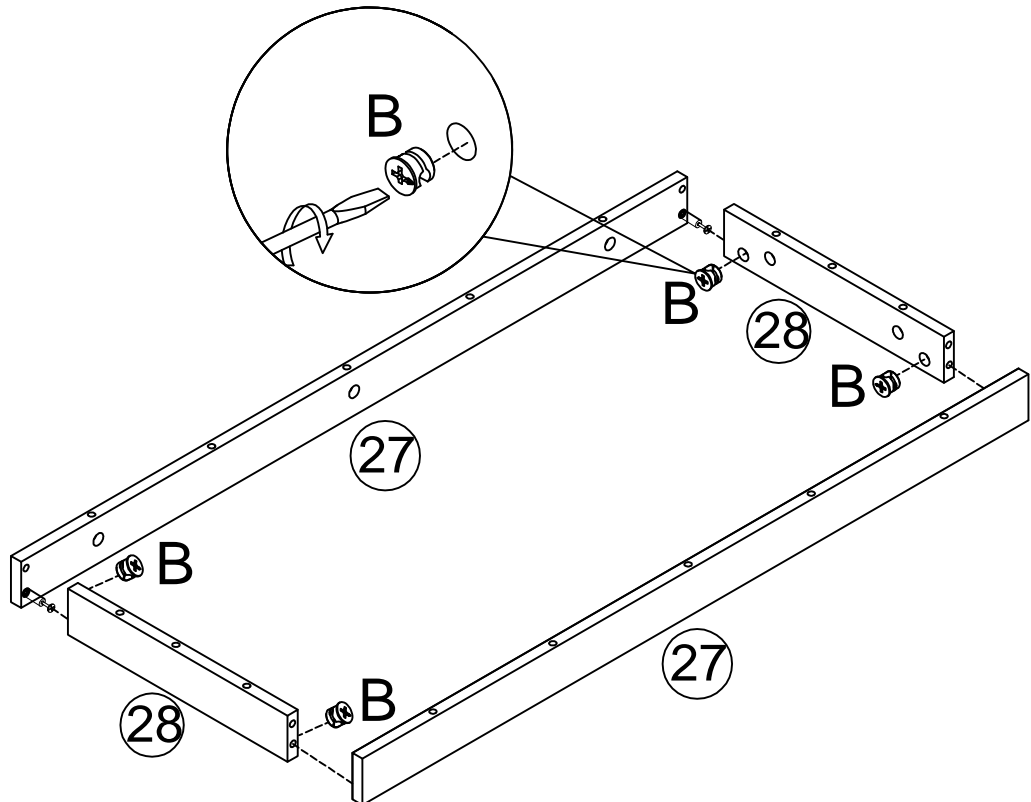

3.

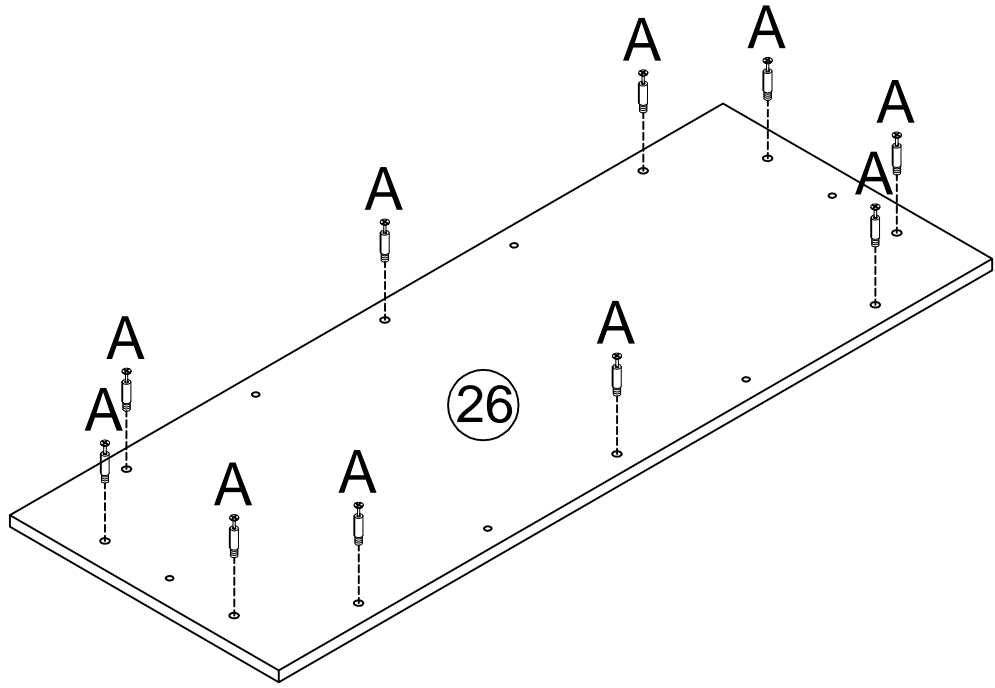
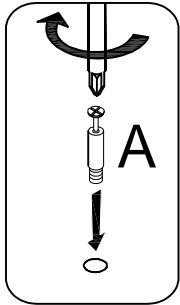

A*10

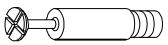

4.

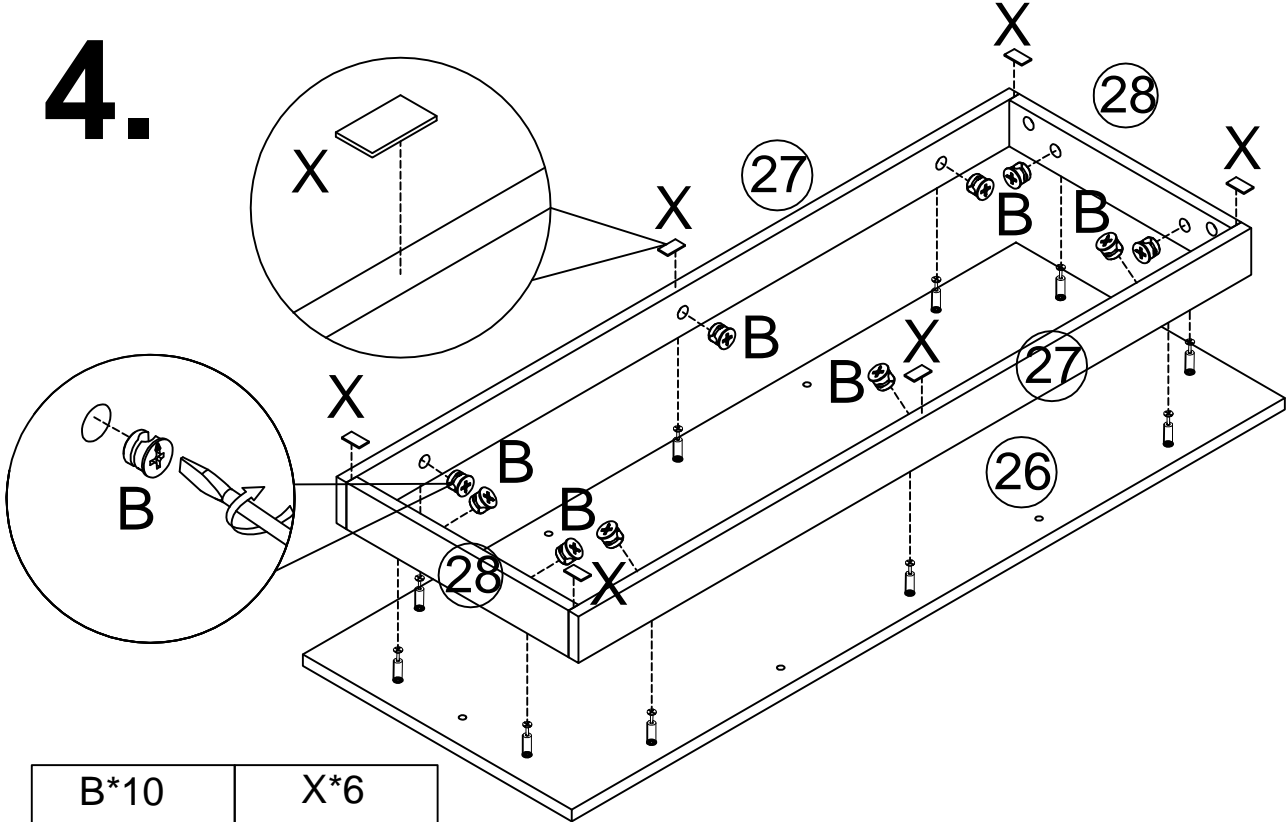

B*10



X*6

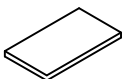

5.

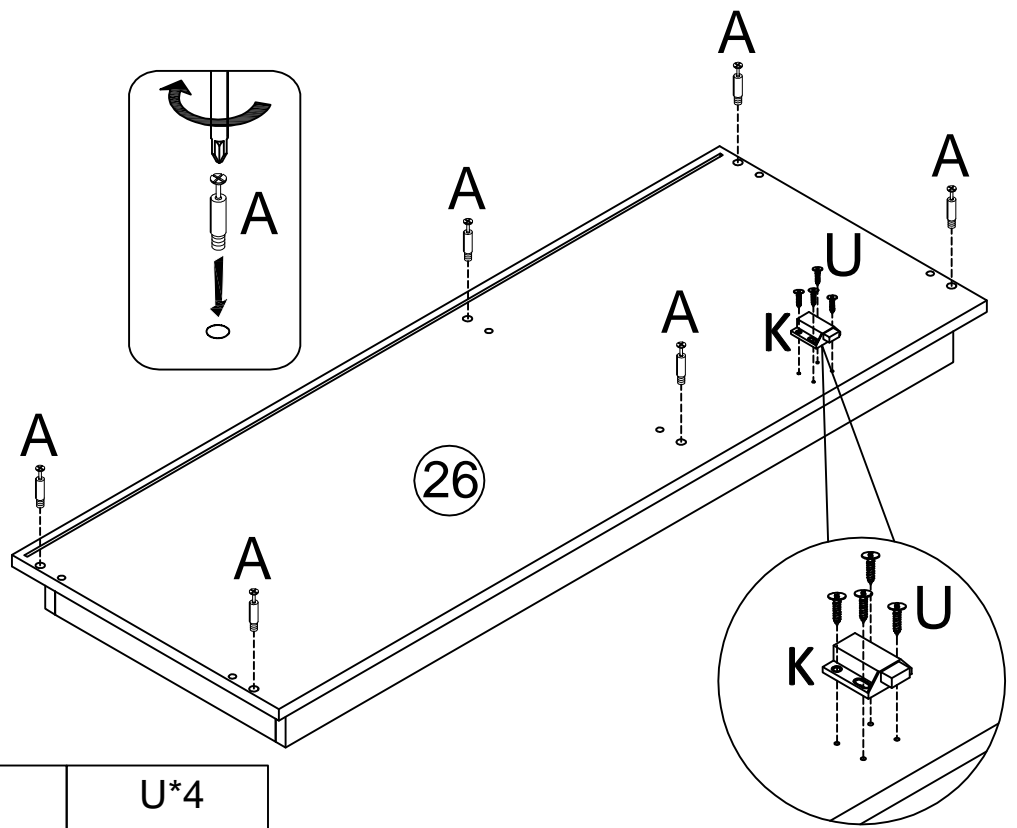

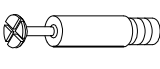
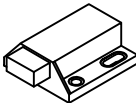
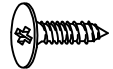
A*6	K*1	U*4
		

6.

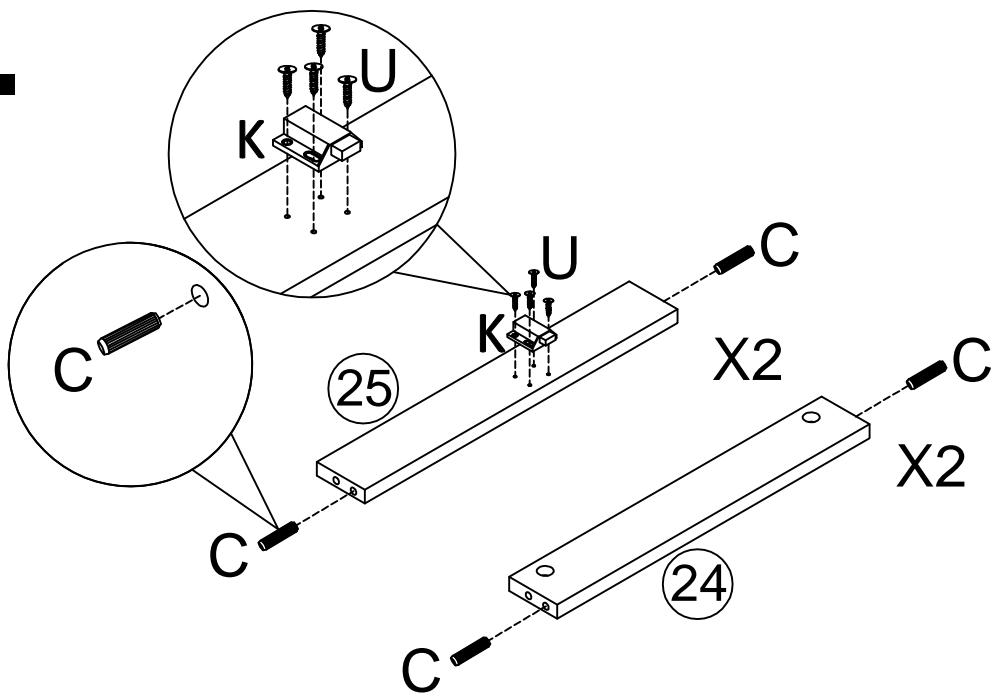

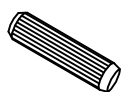
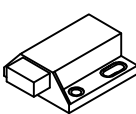
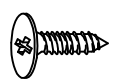
C*8	K*2	U*8
		

7.

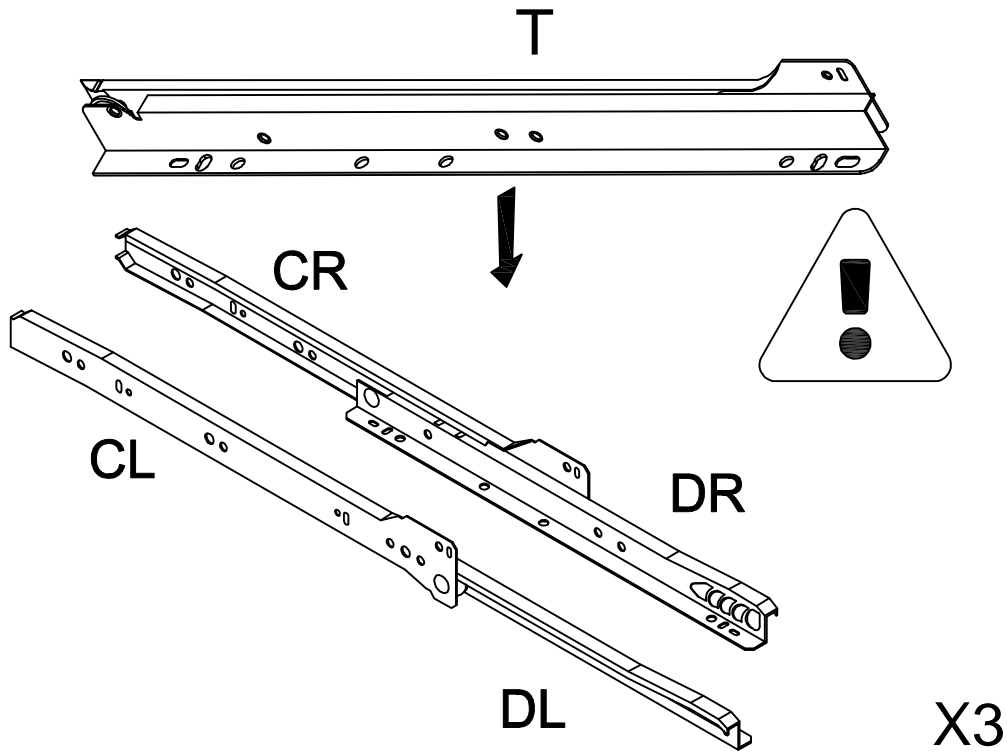

8.

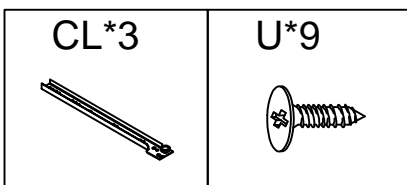
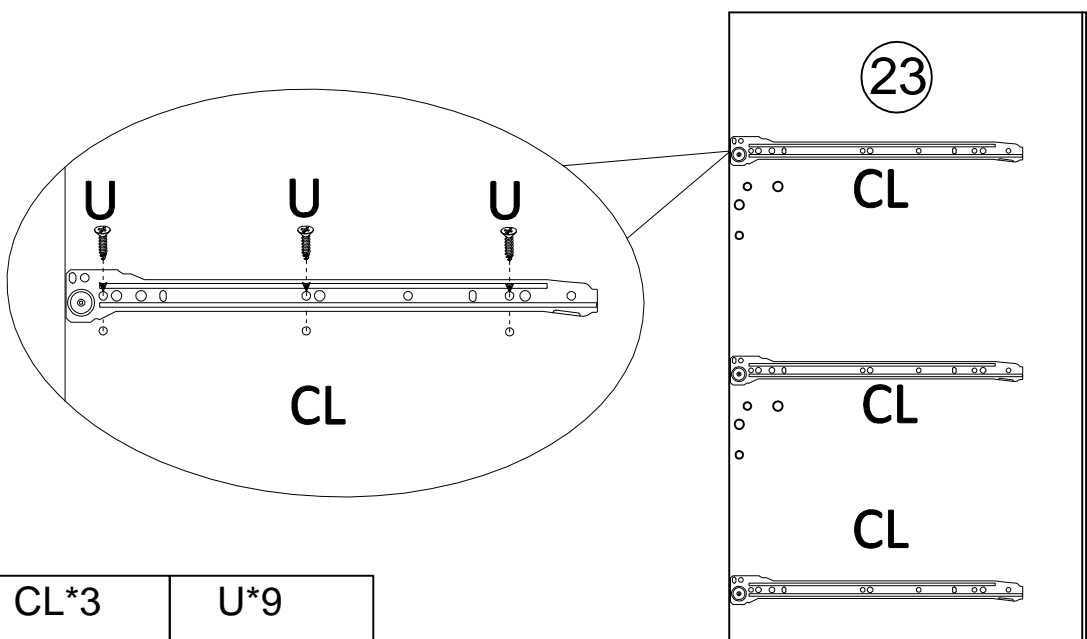

9.

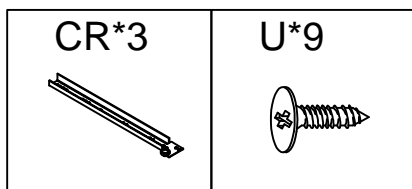
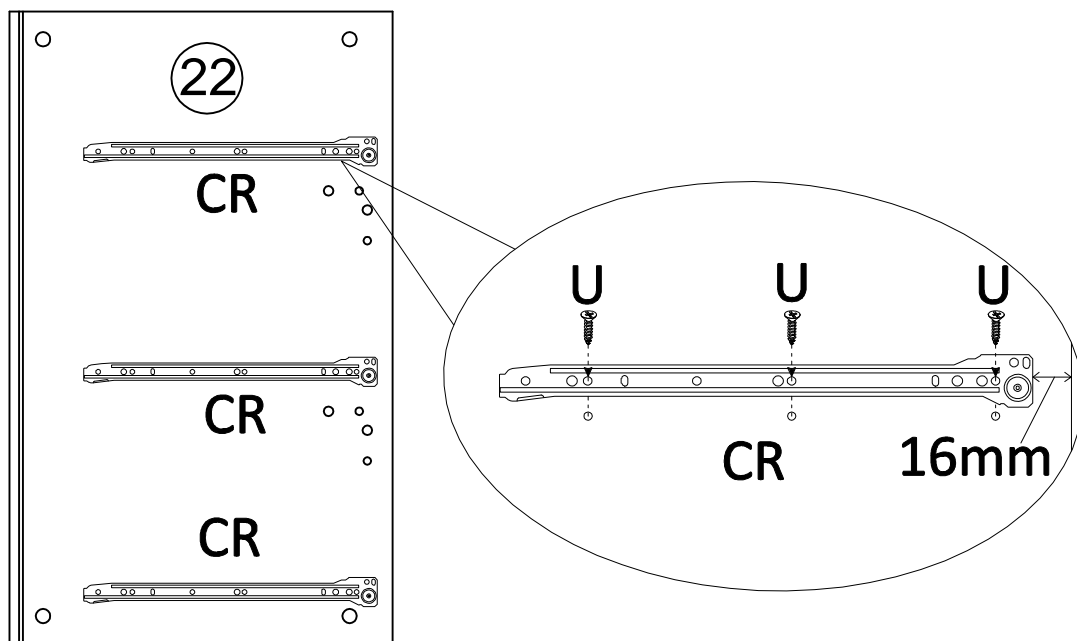

10.

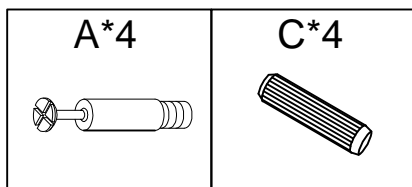
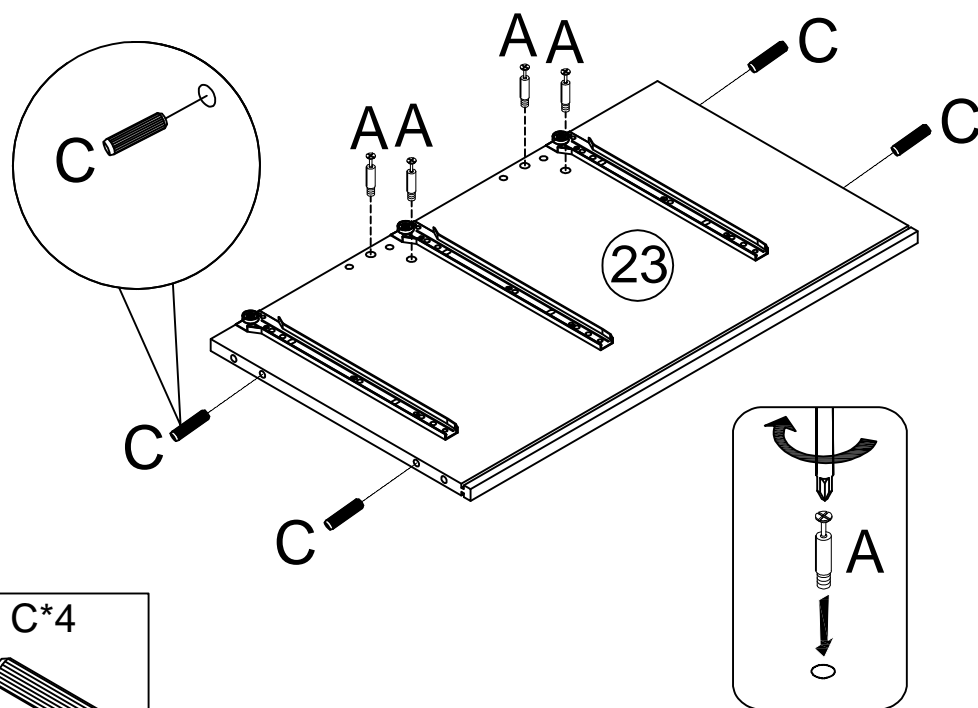

11.

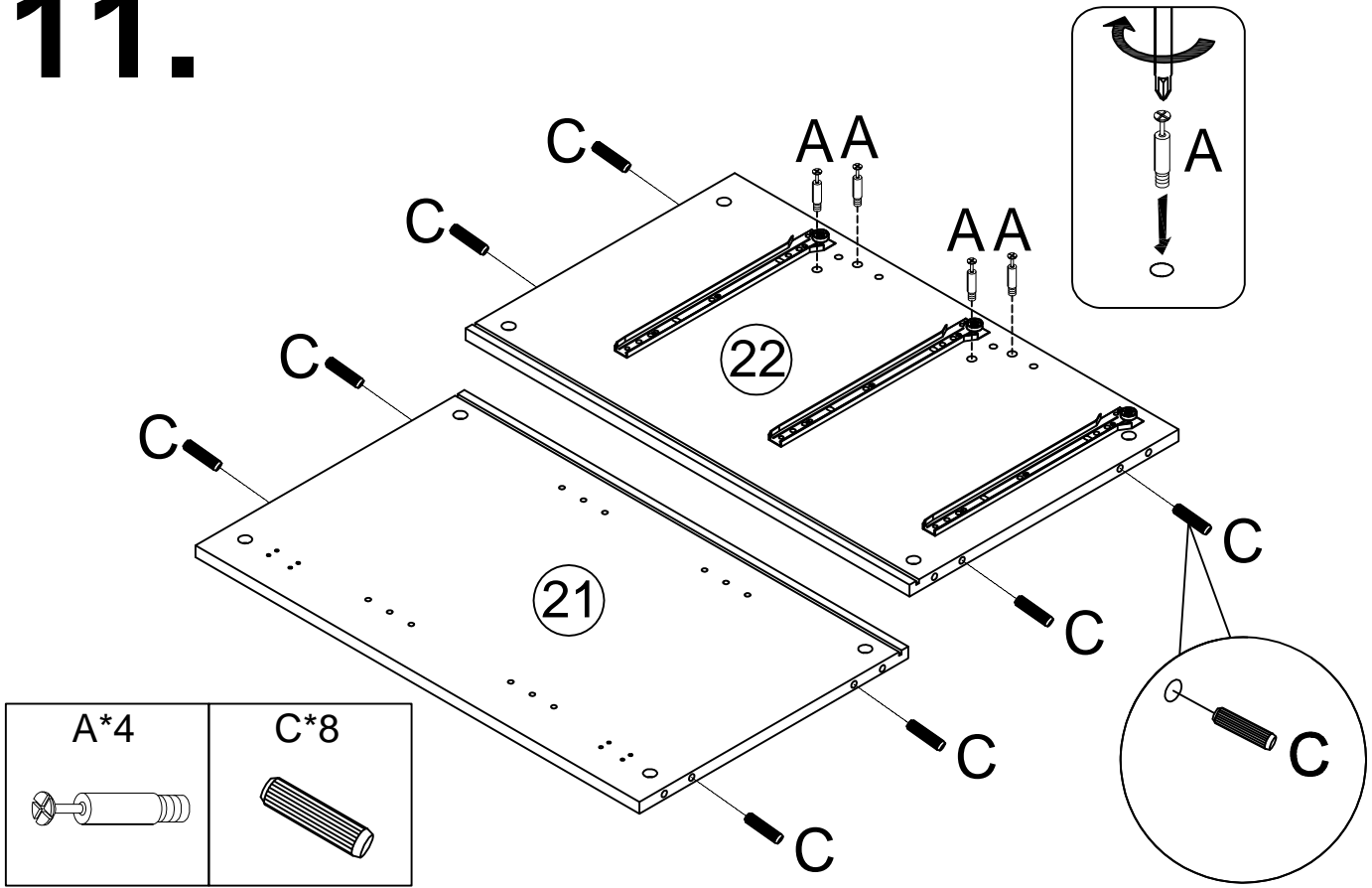

12.

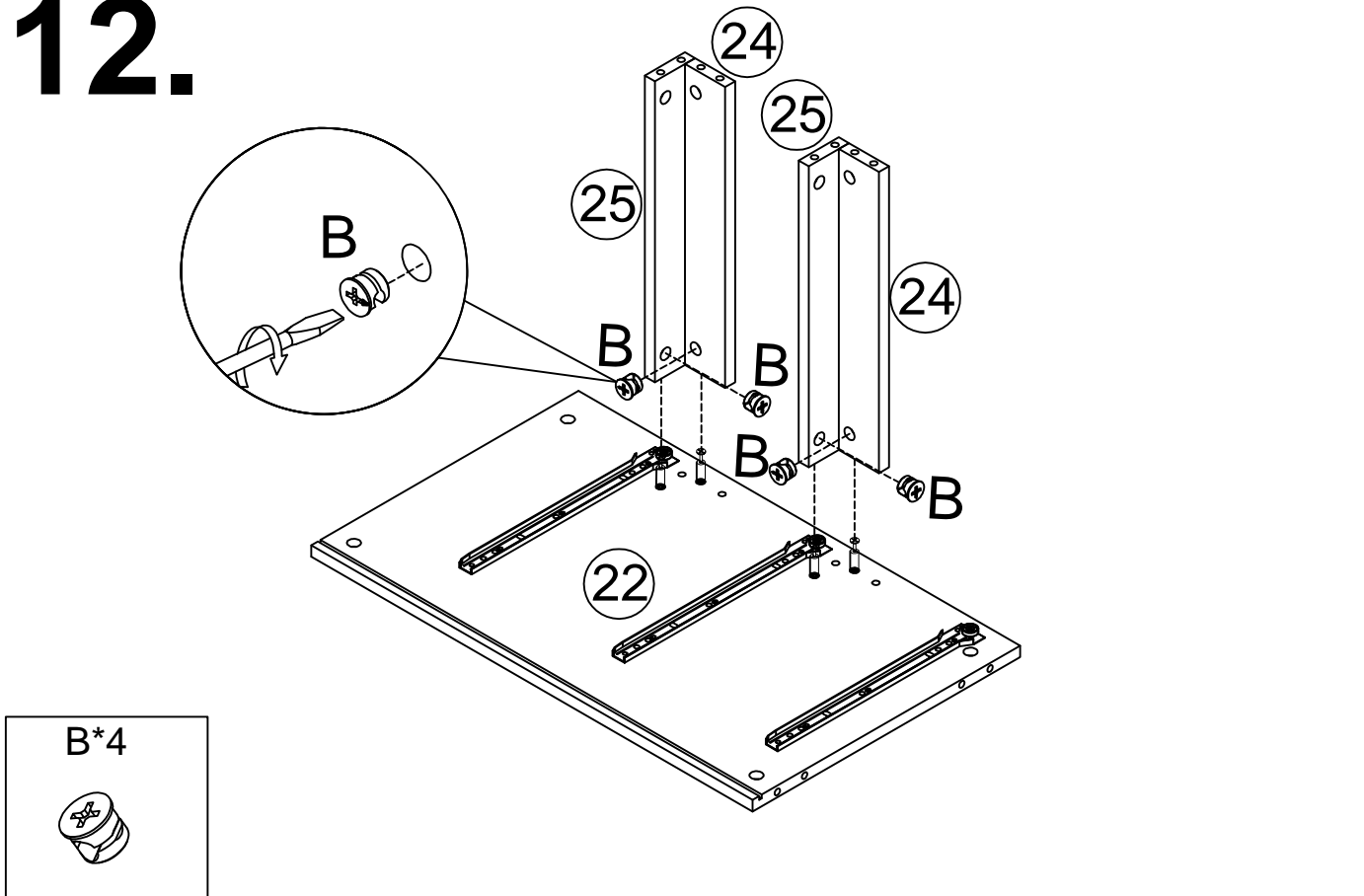

13.

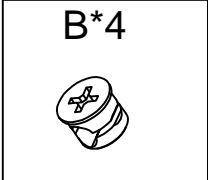
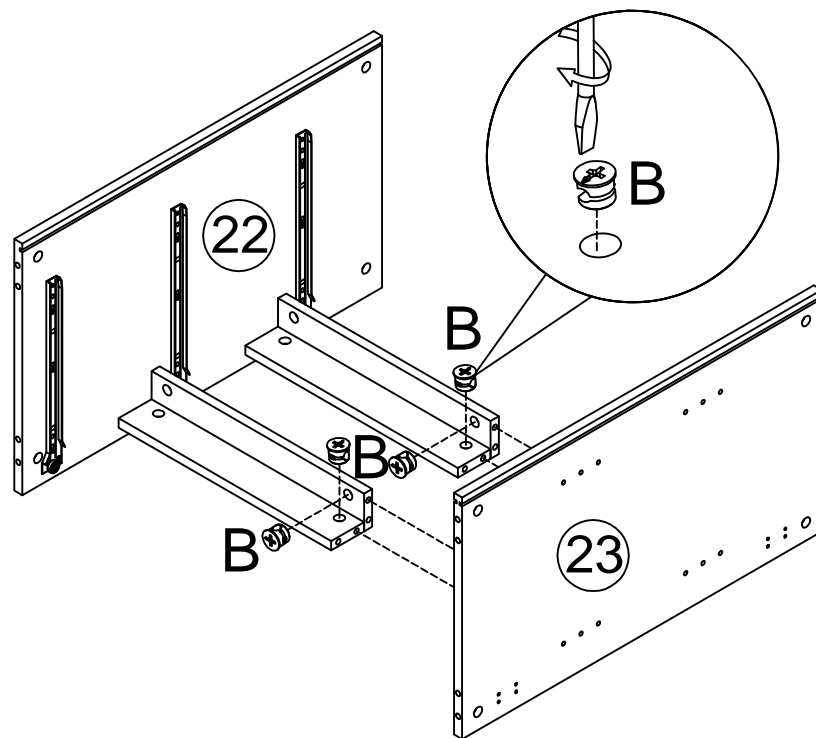

14.

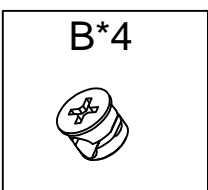
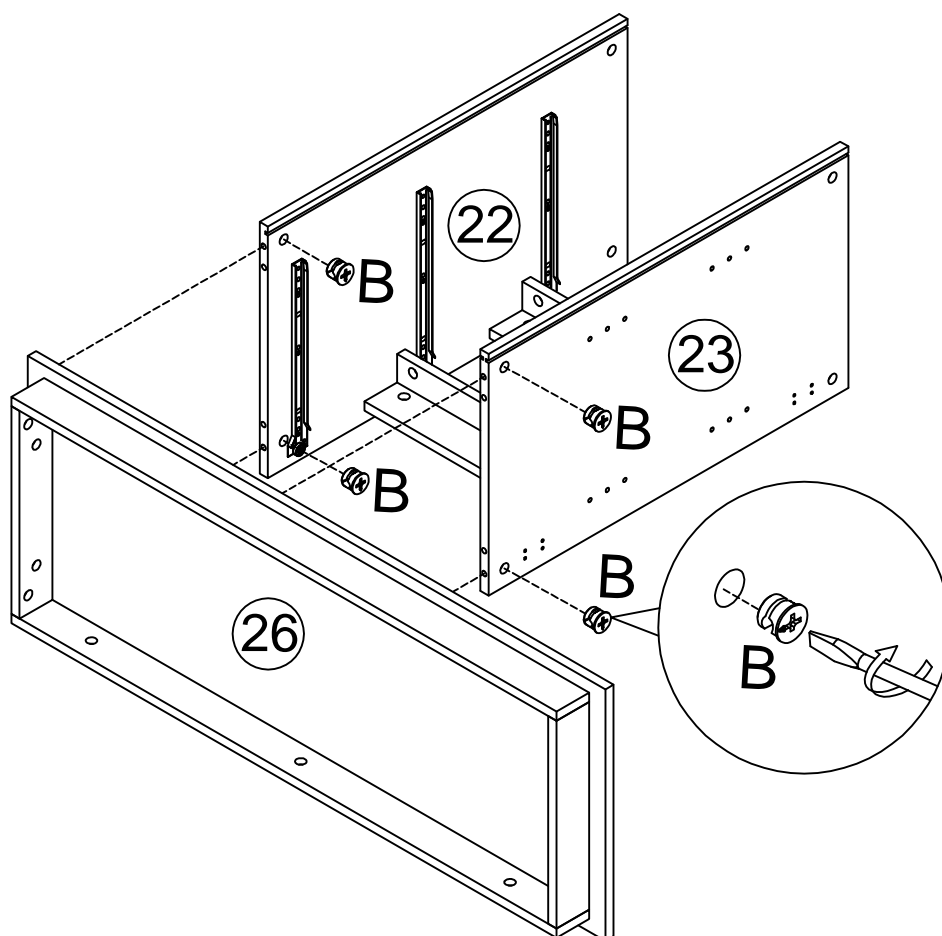

15.

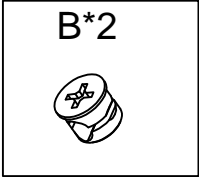
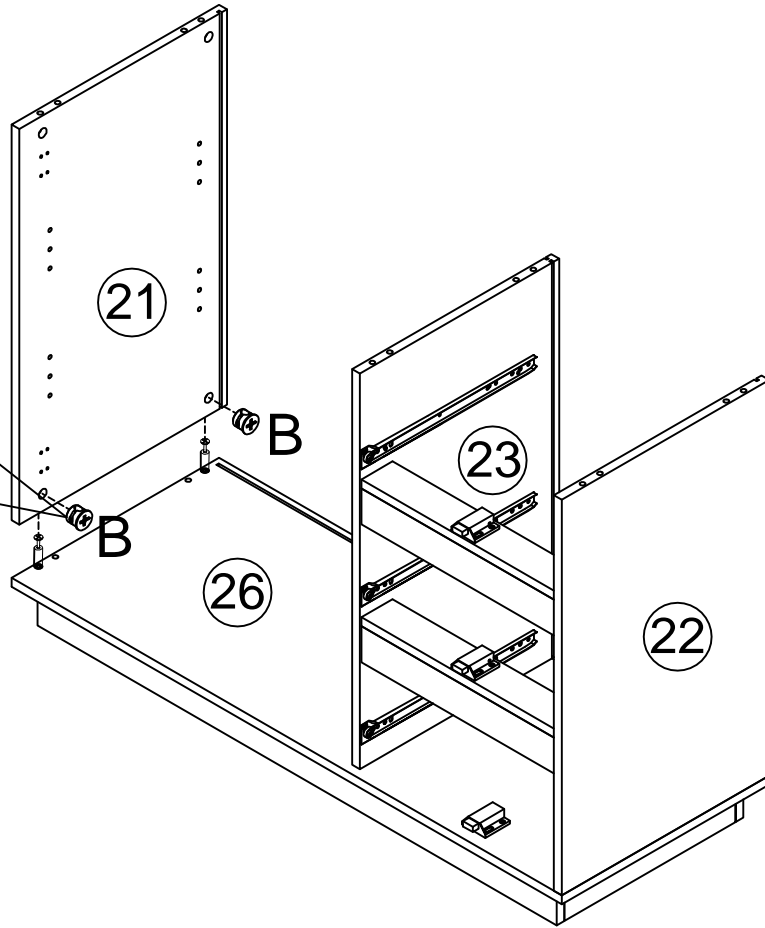
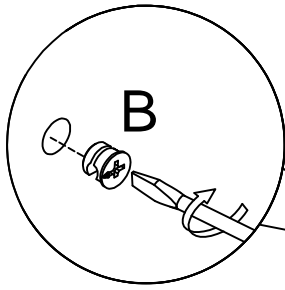

16.

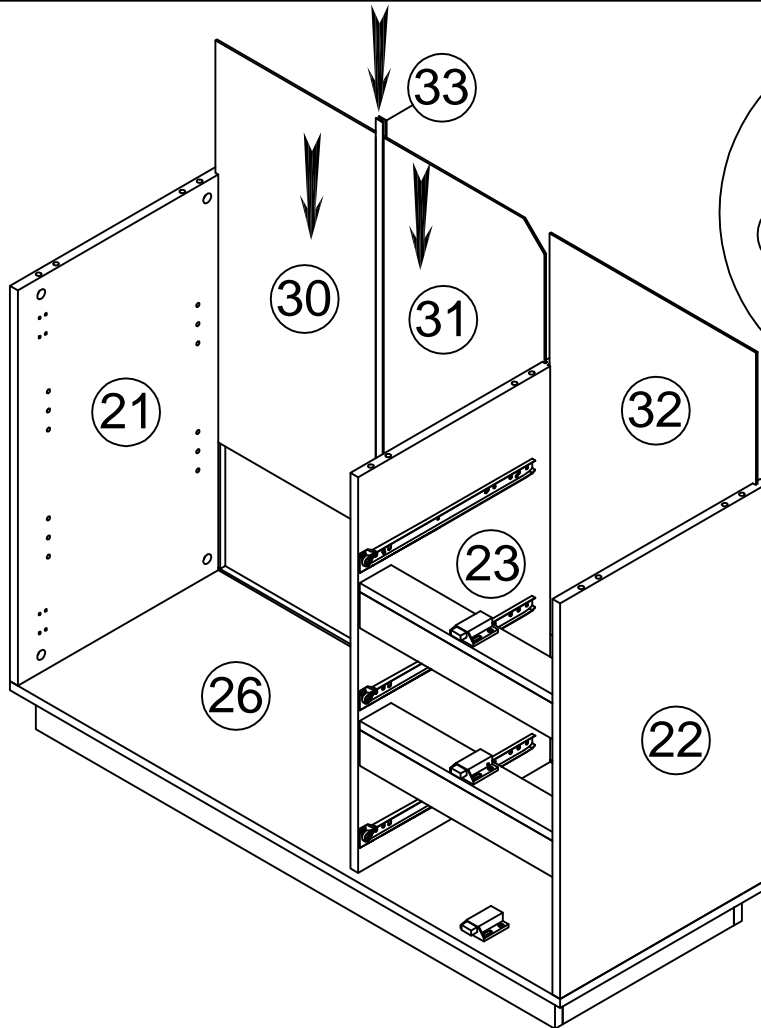
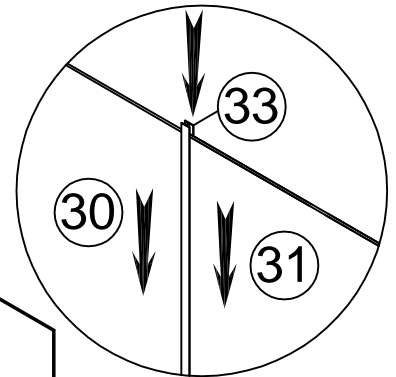

17.

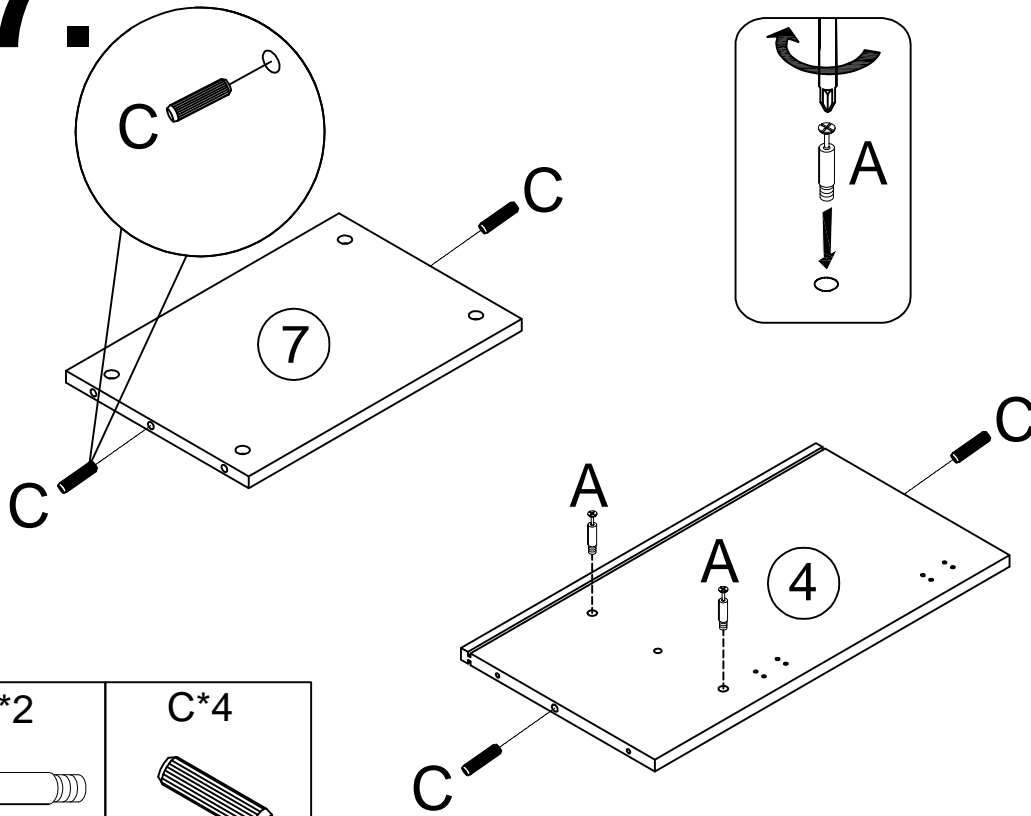

18.

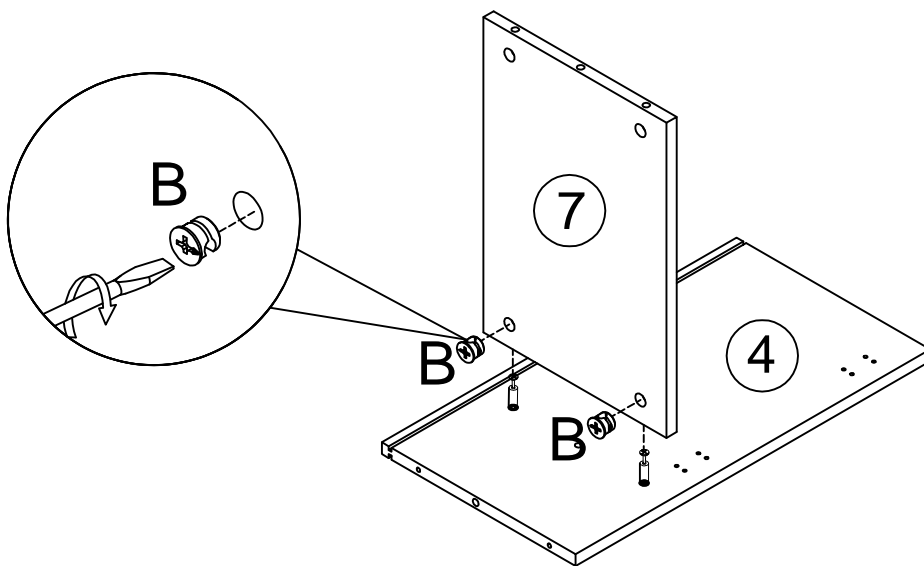

19.

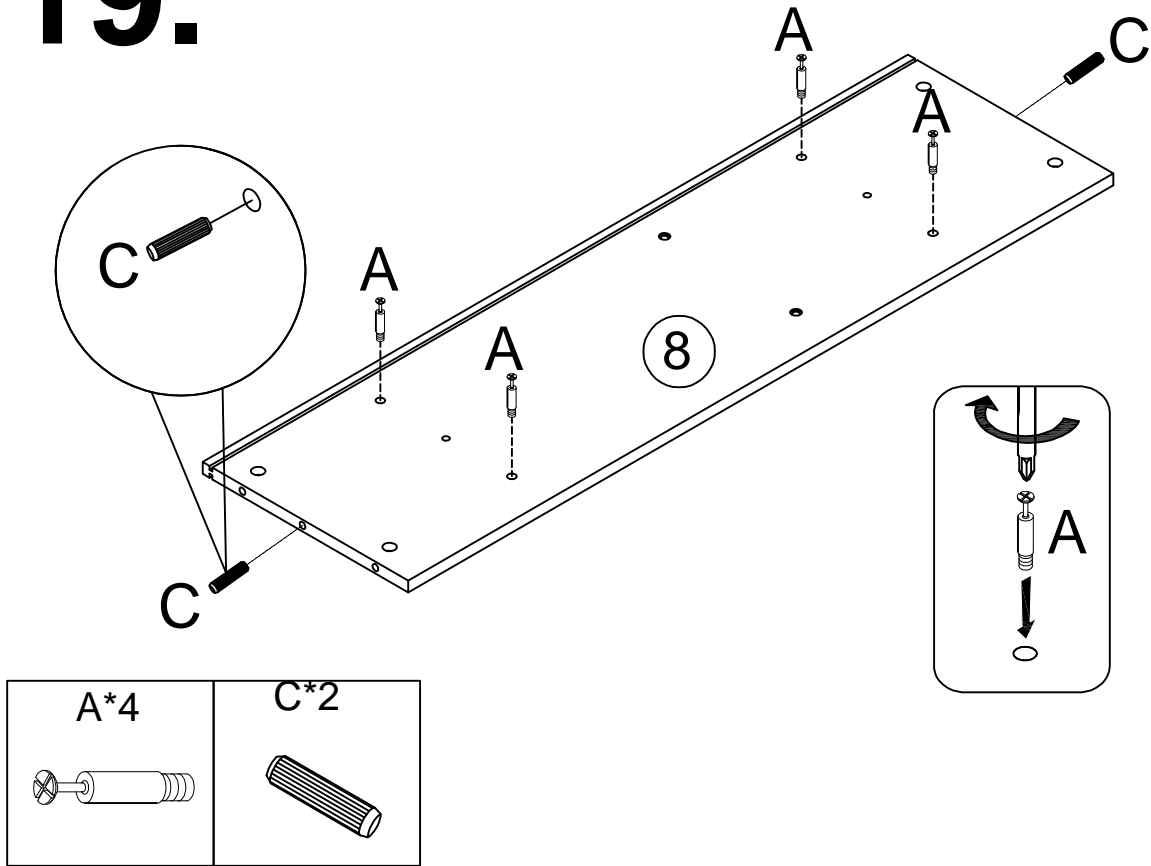

20.

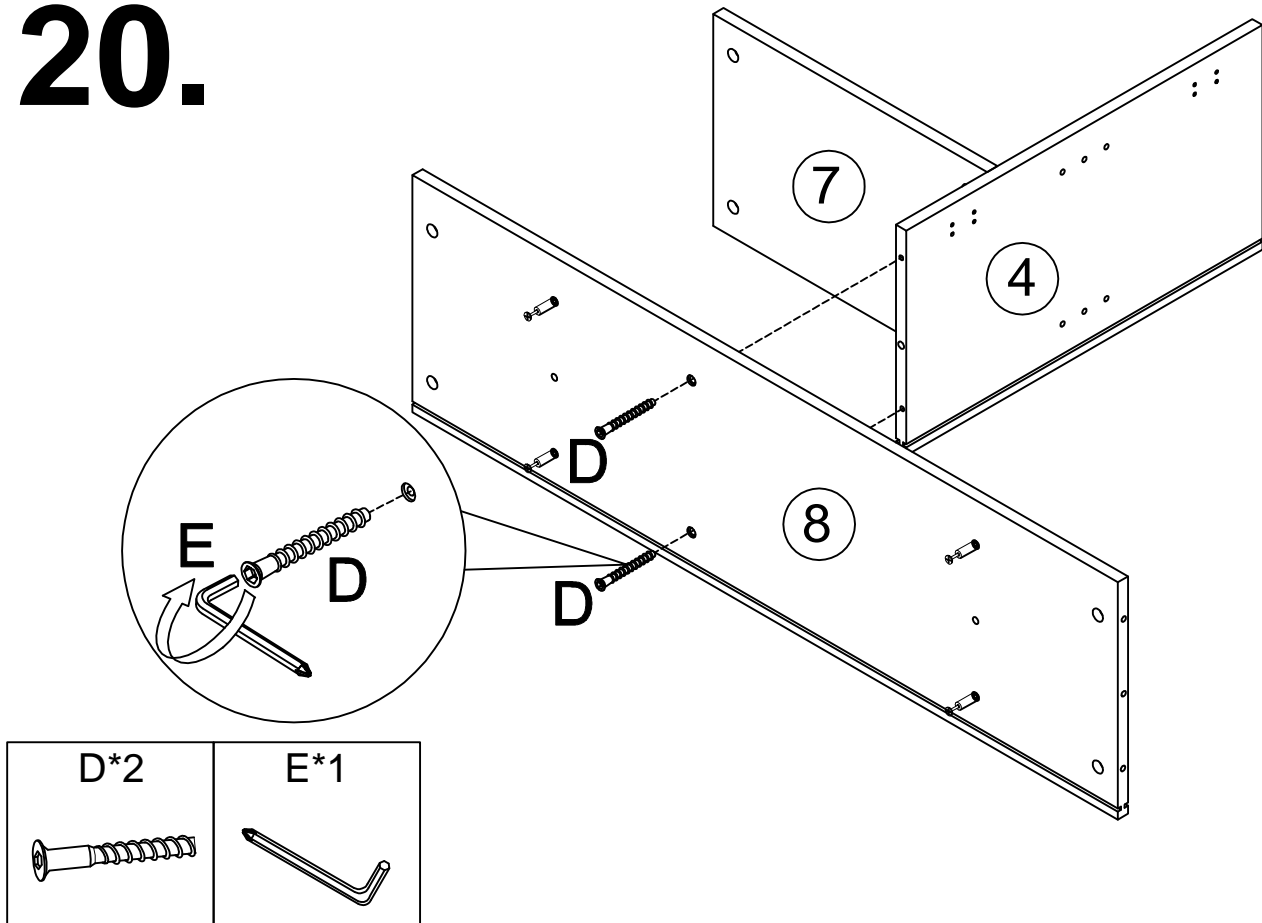

21.

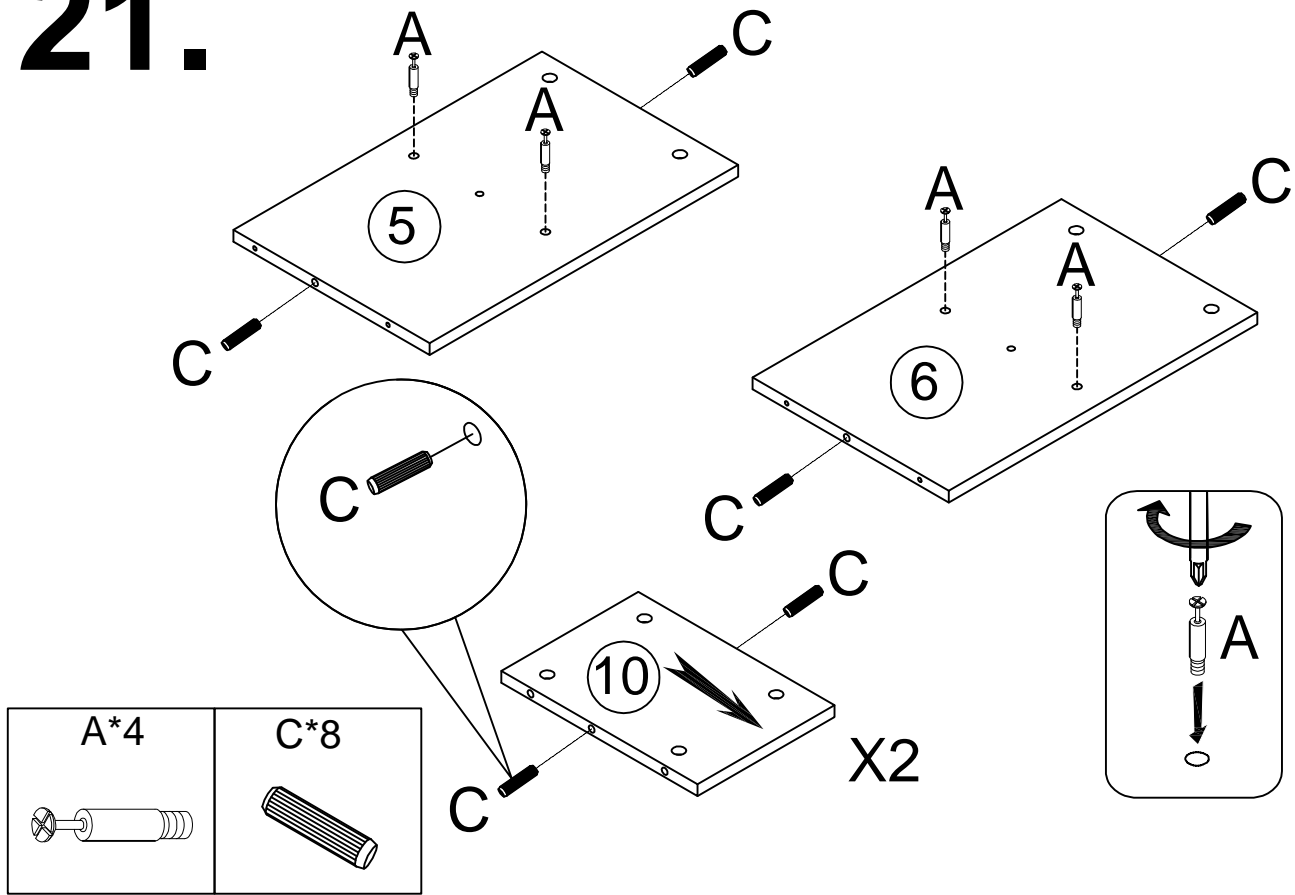

22.

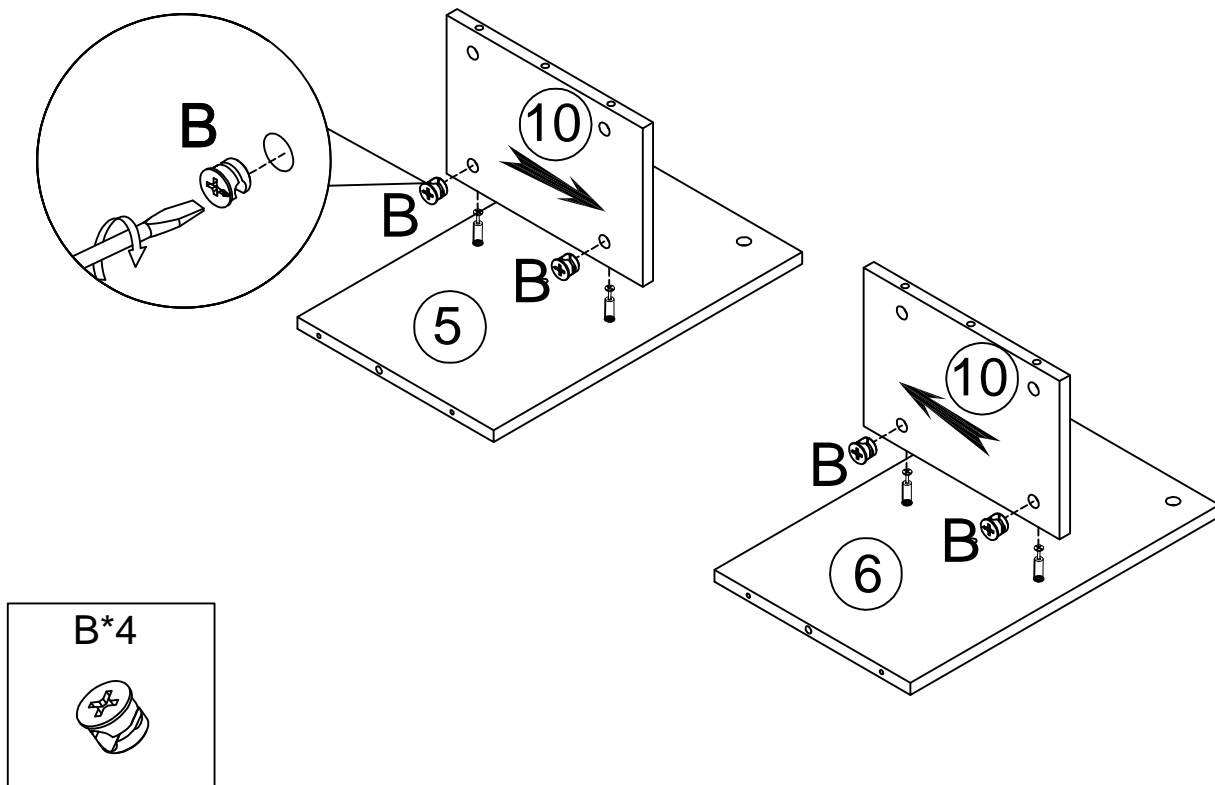

23.

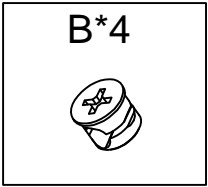
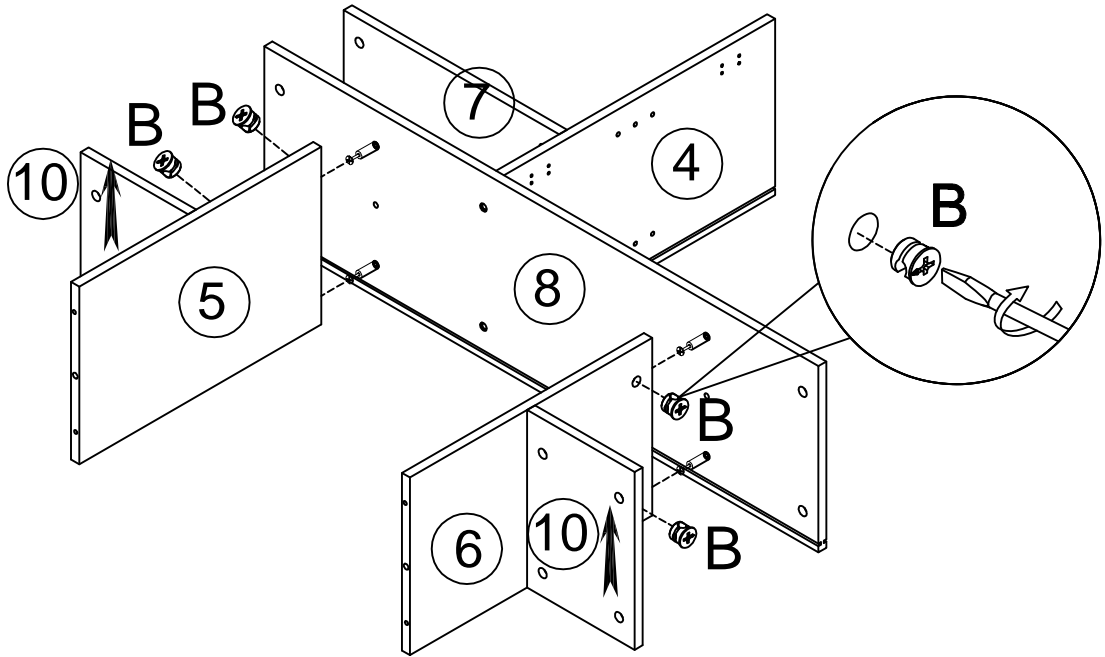

24.

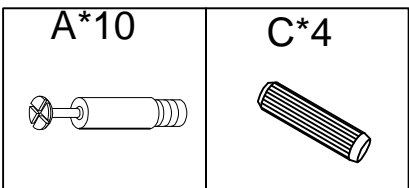
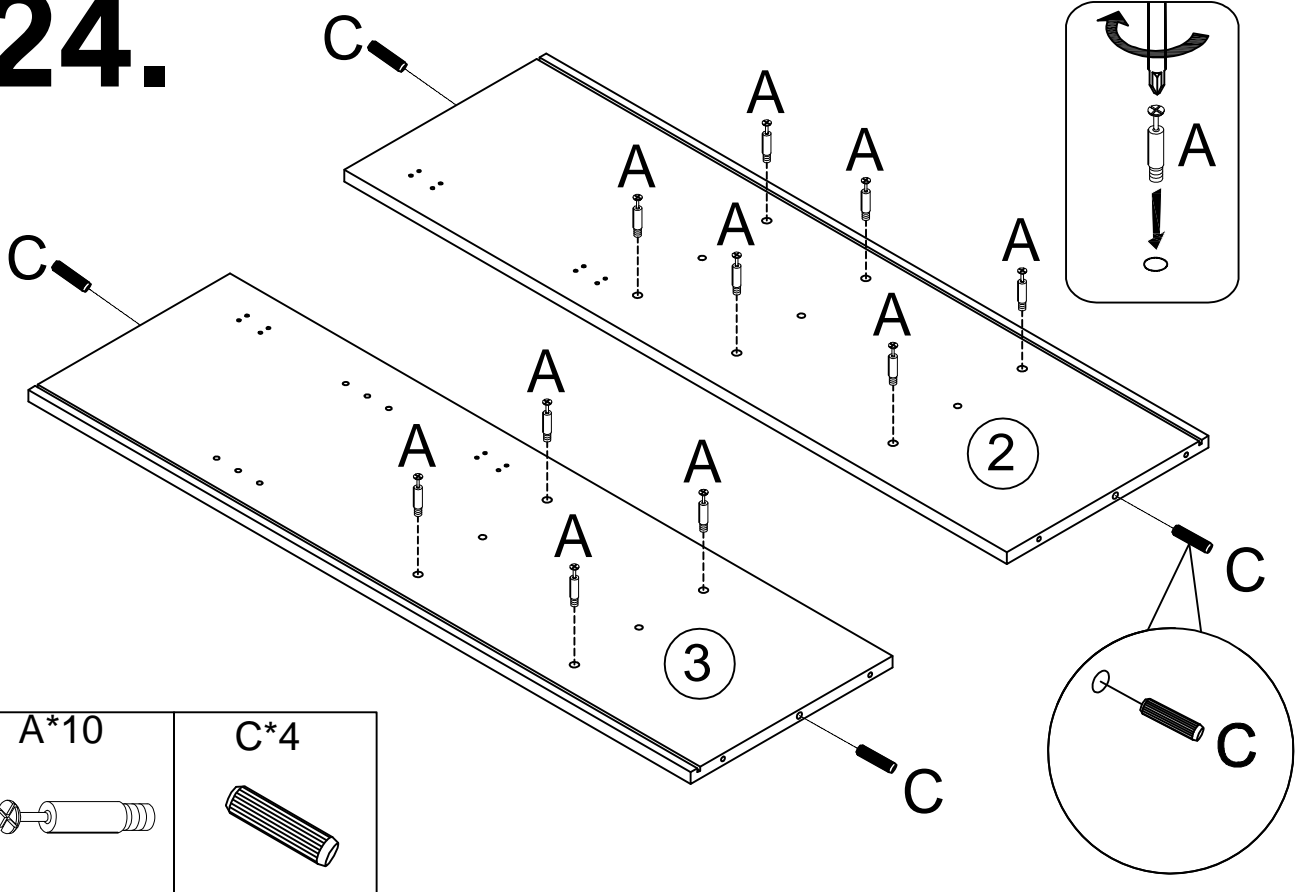

25.

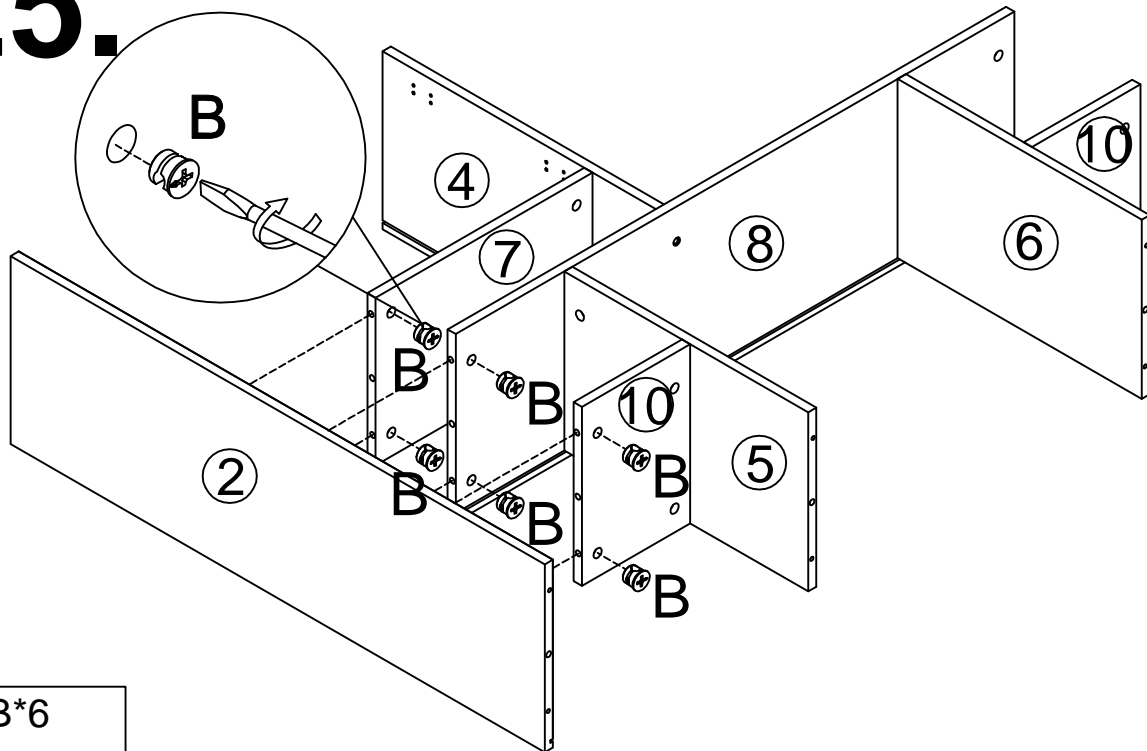

B*6



26.

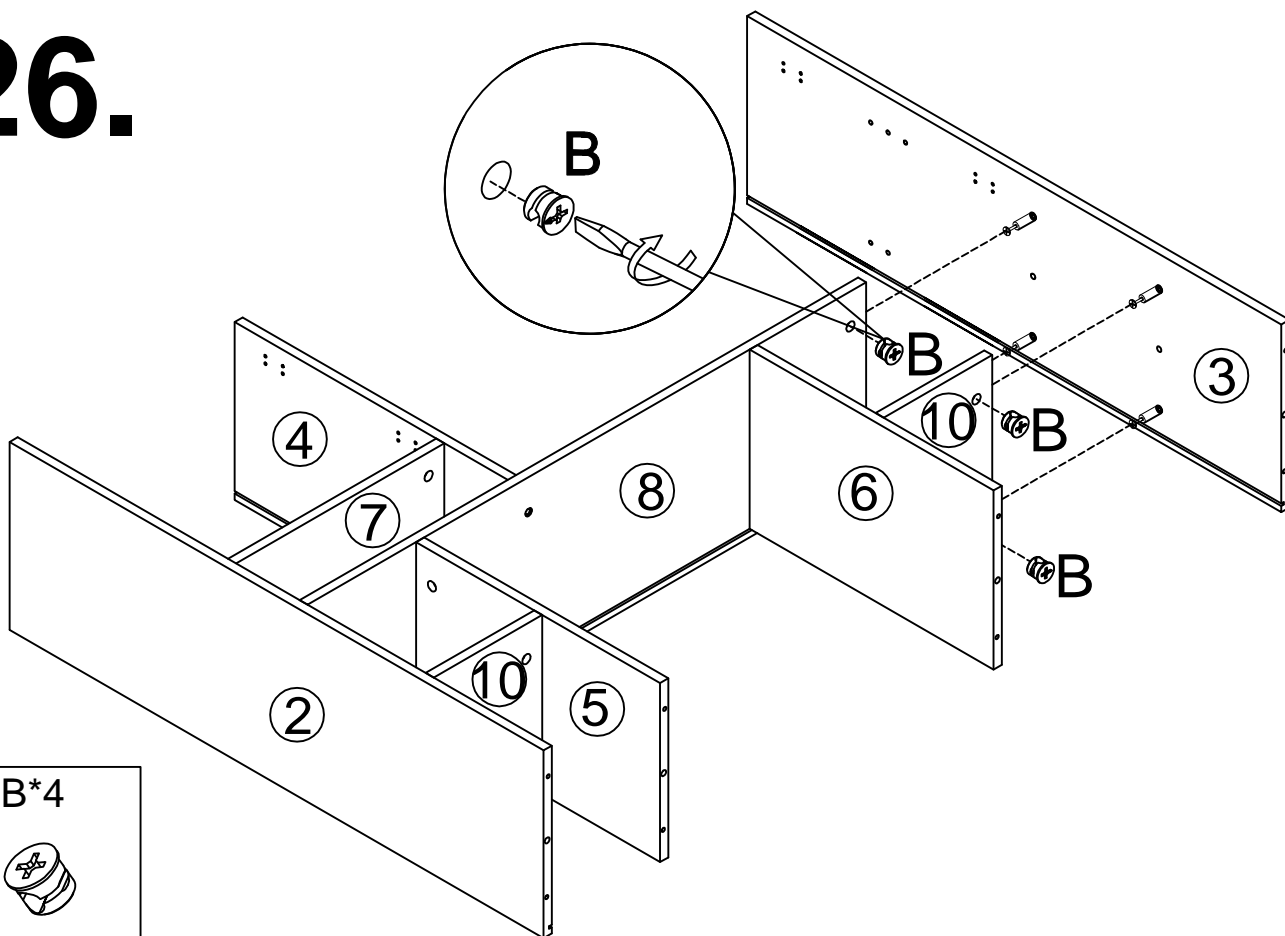

B*4



27.

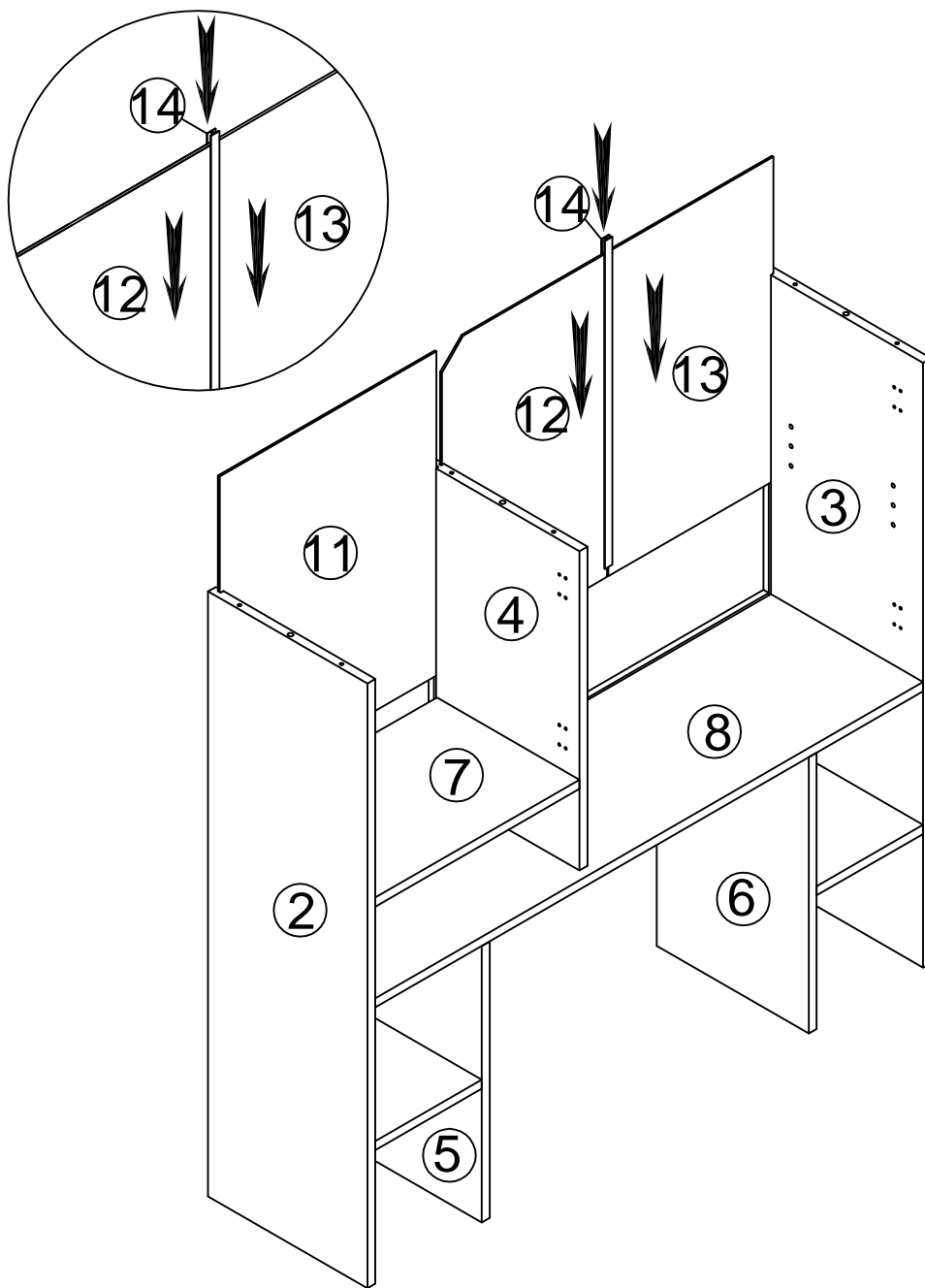

28.

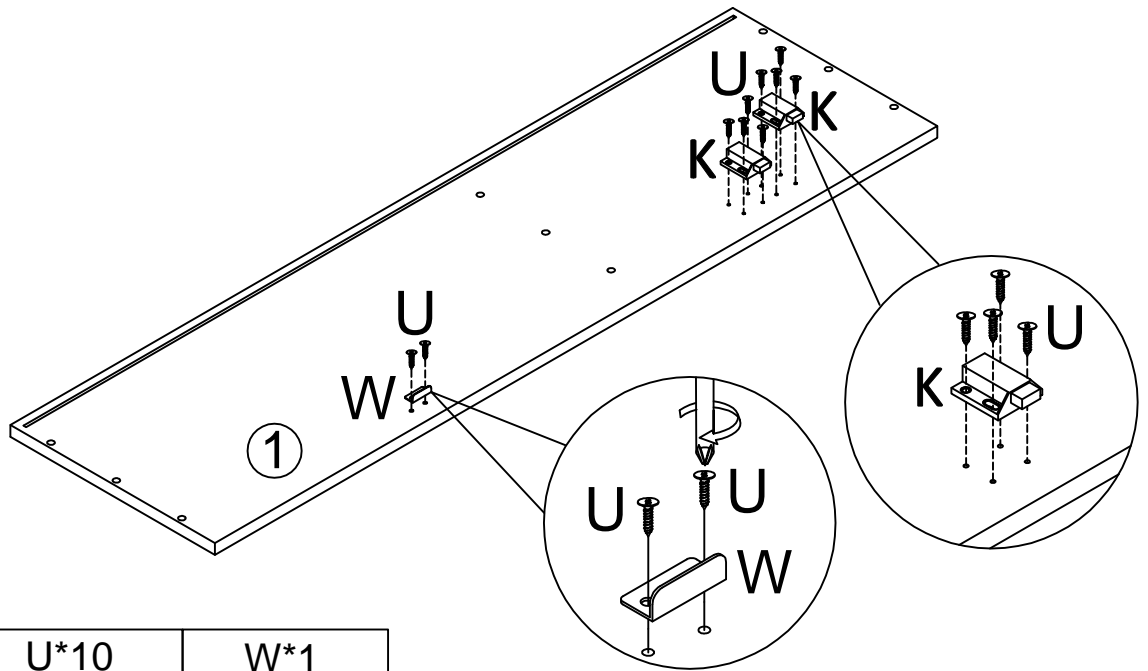

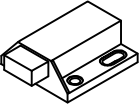
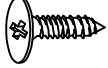
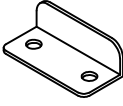
K*2	U*10	W*1
		

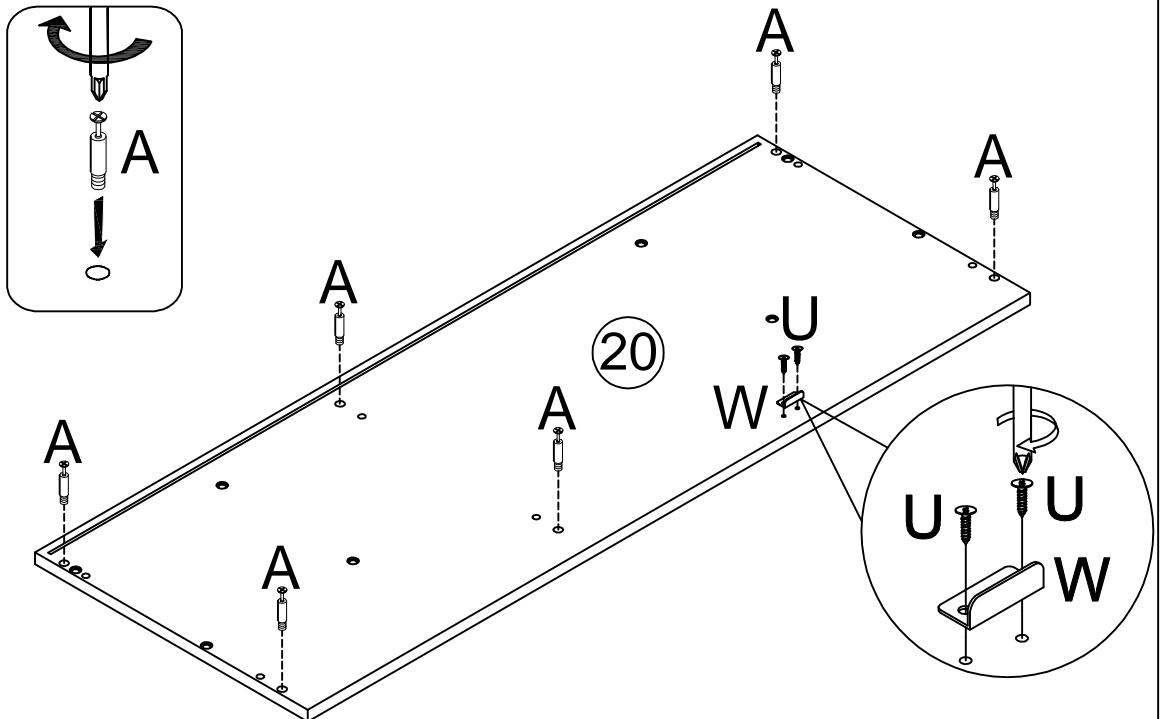

29.

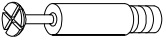
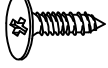
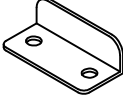

A*6	U*2	W*1
		

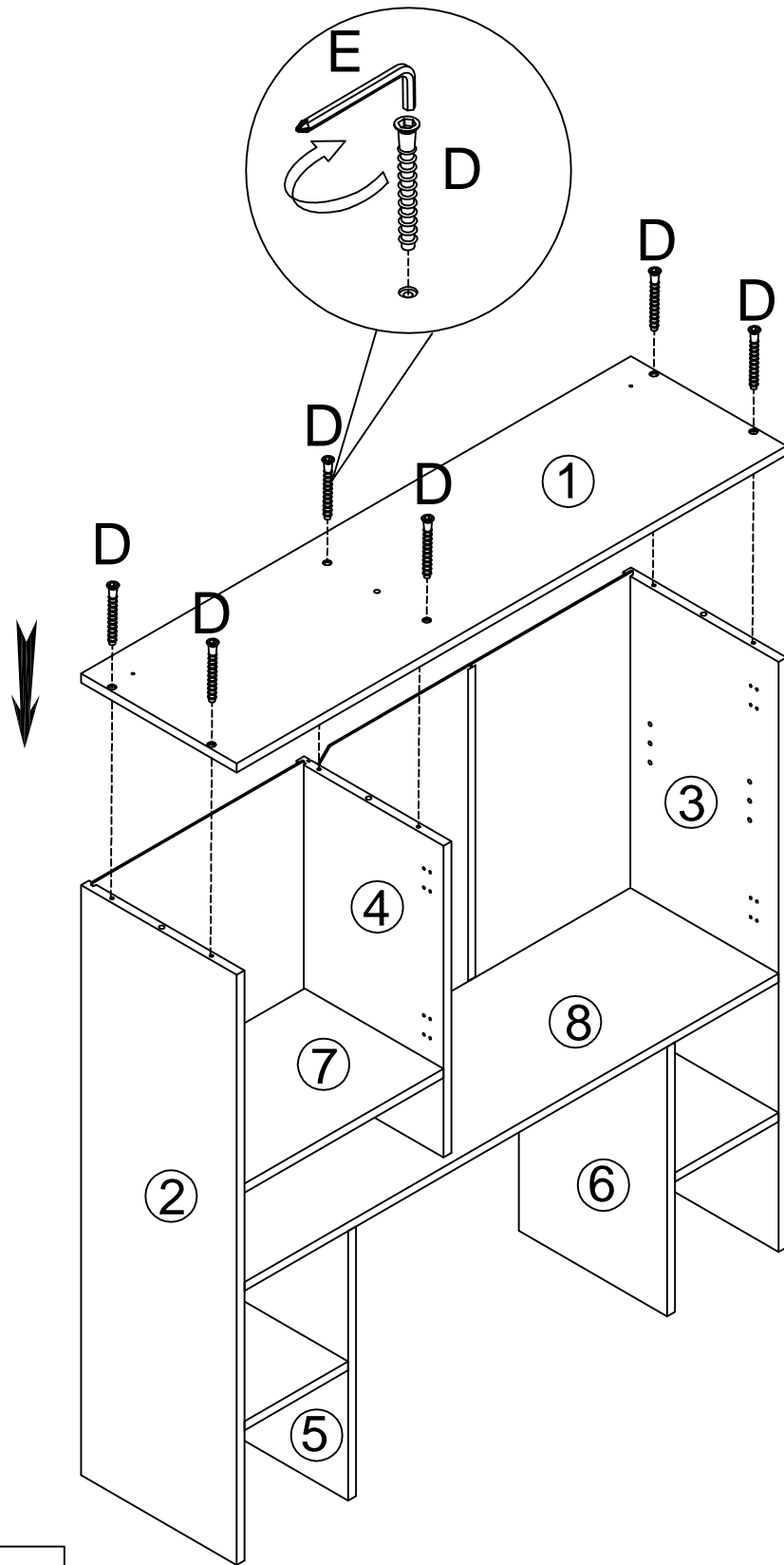
30.



D*6	E*1
	

31.

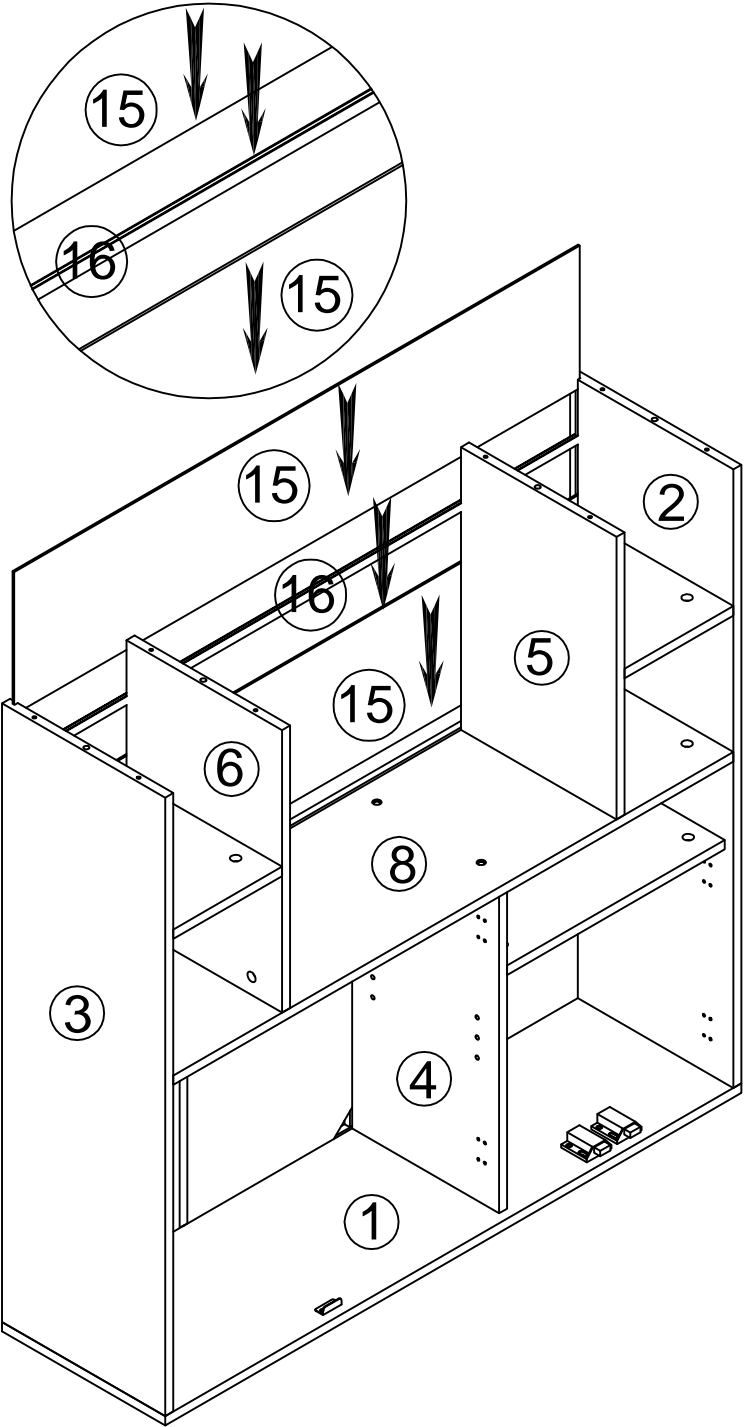

32.

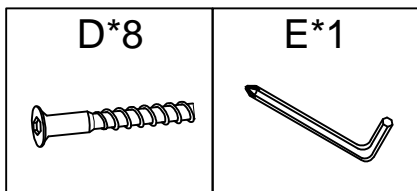
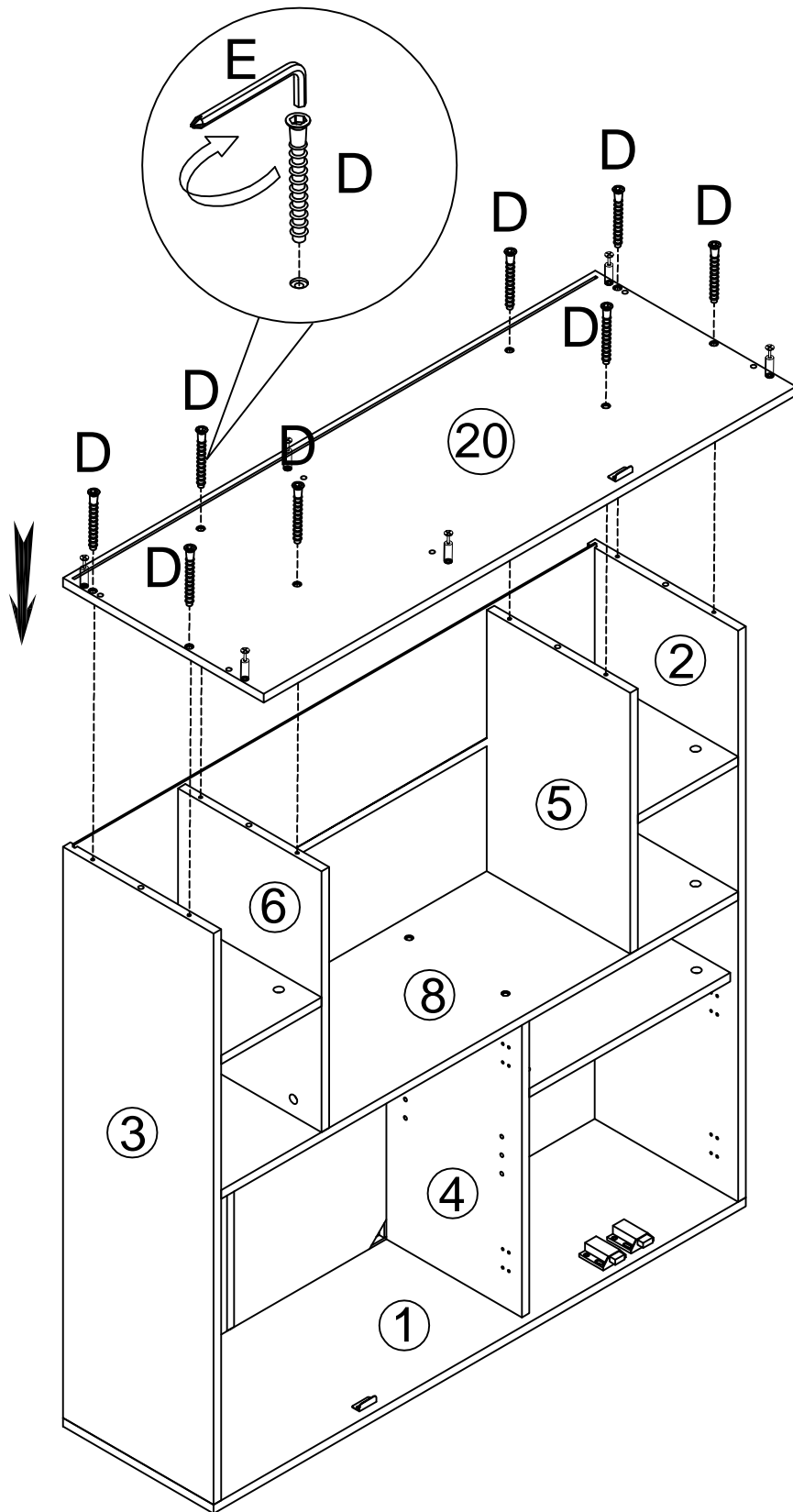

33.

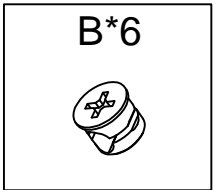
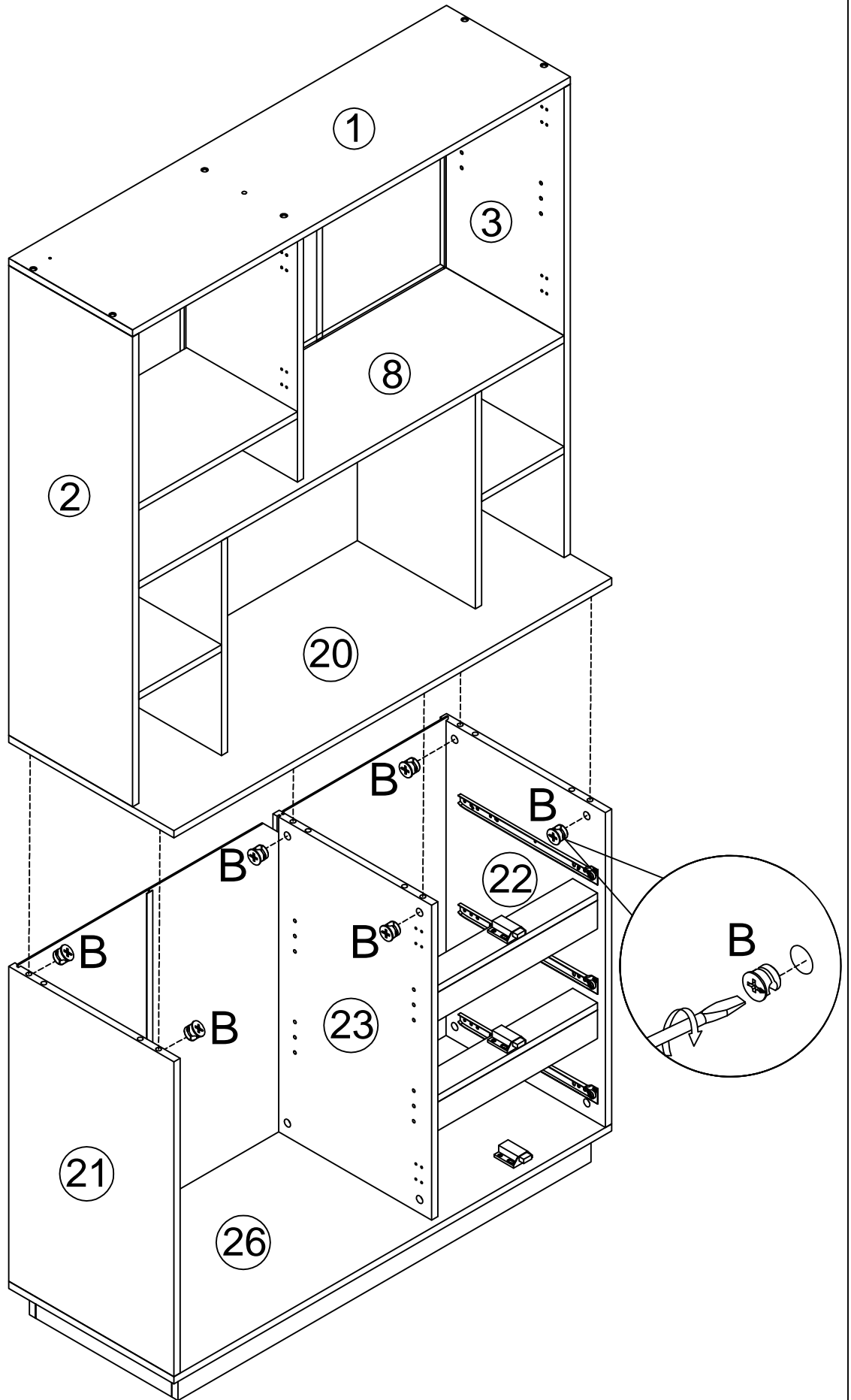

34.

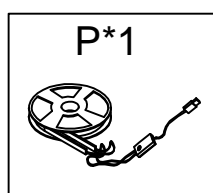
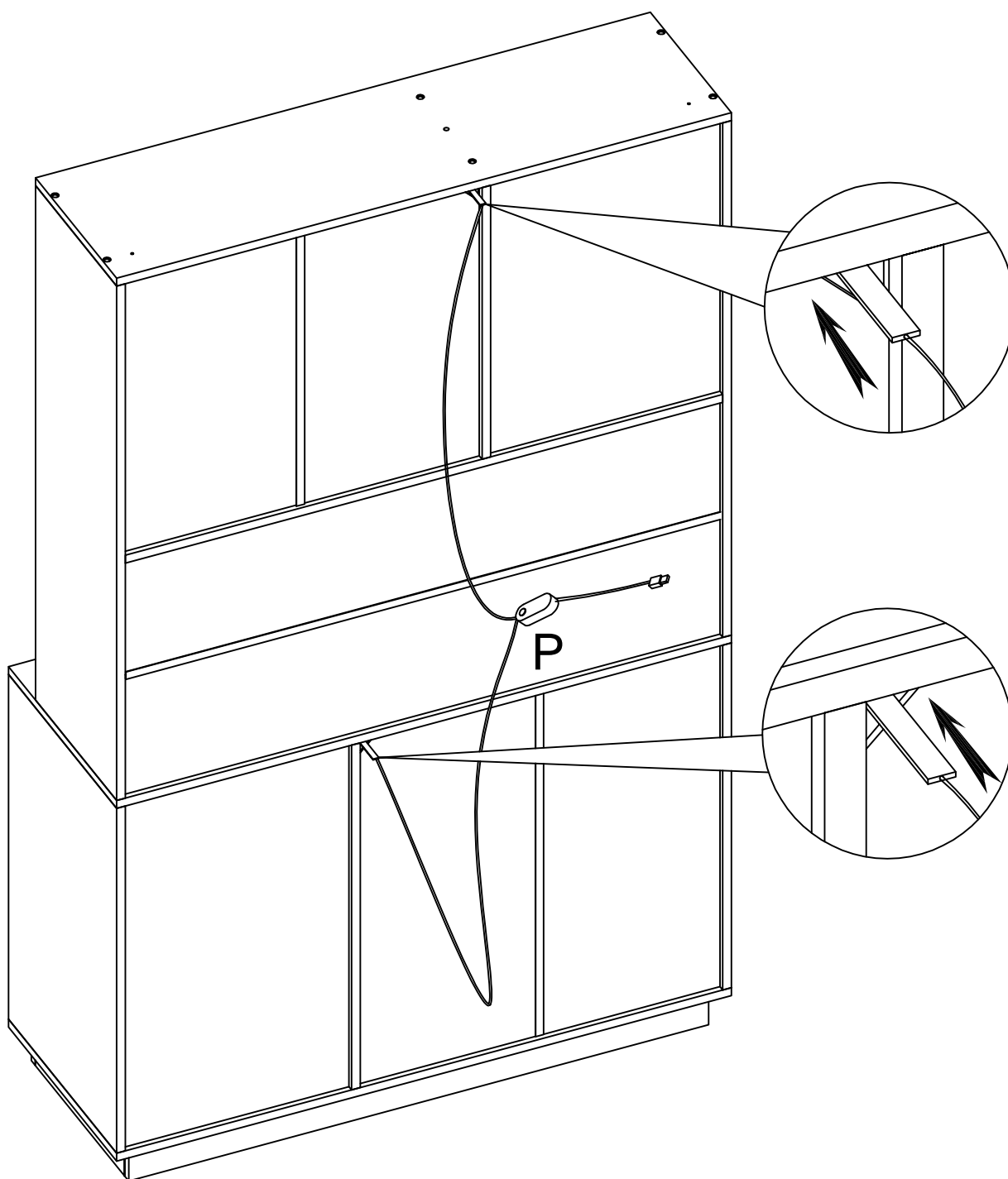

35.

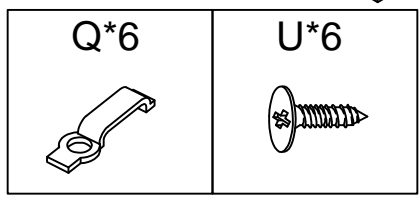
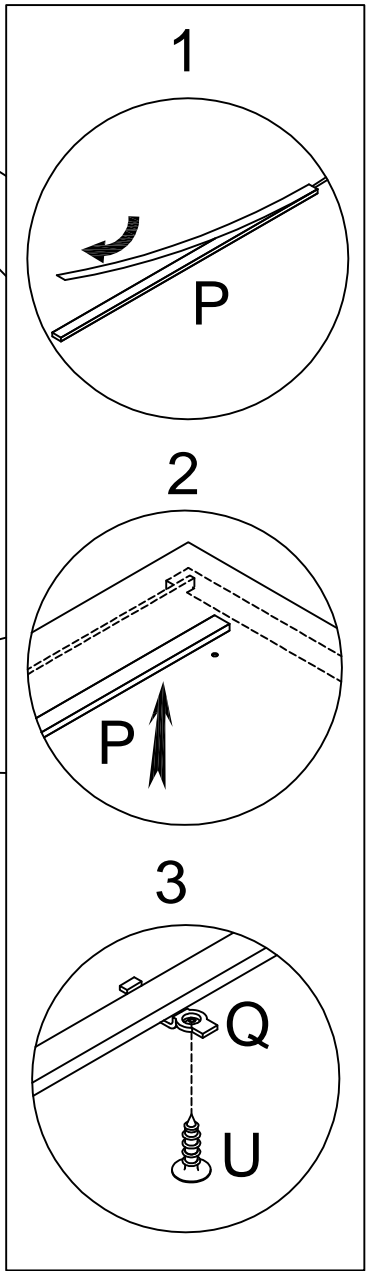
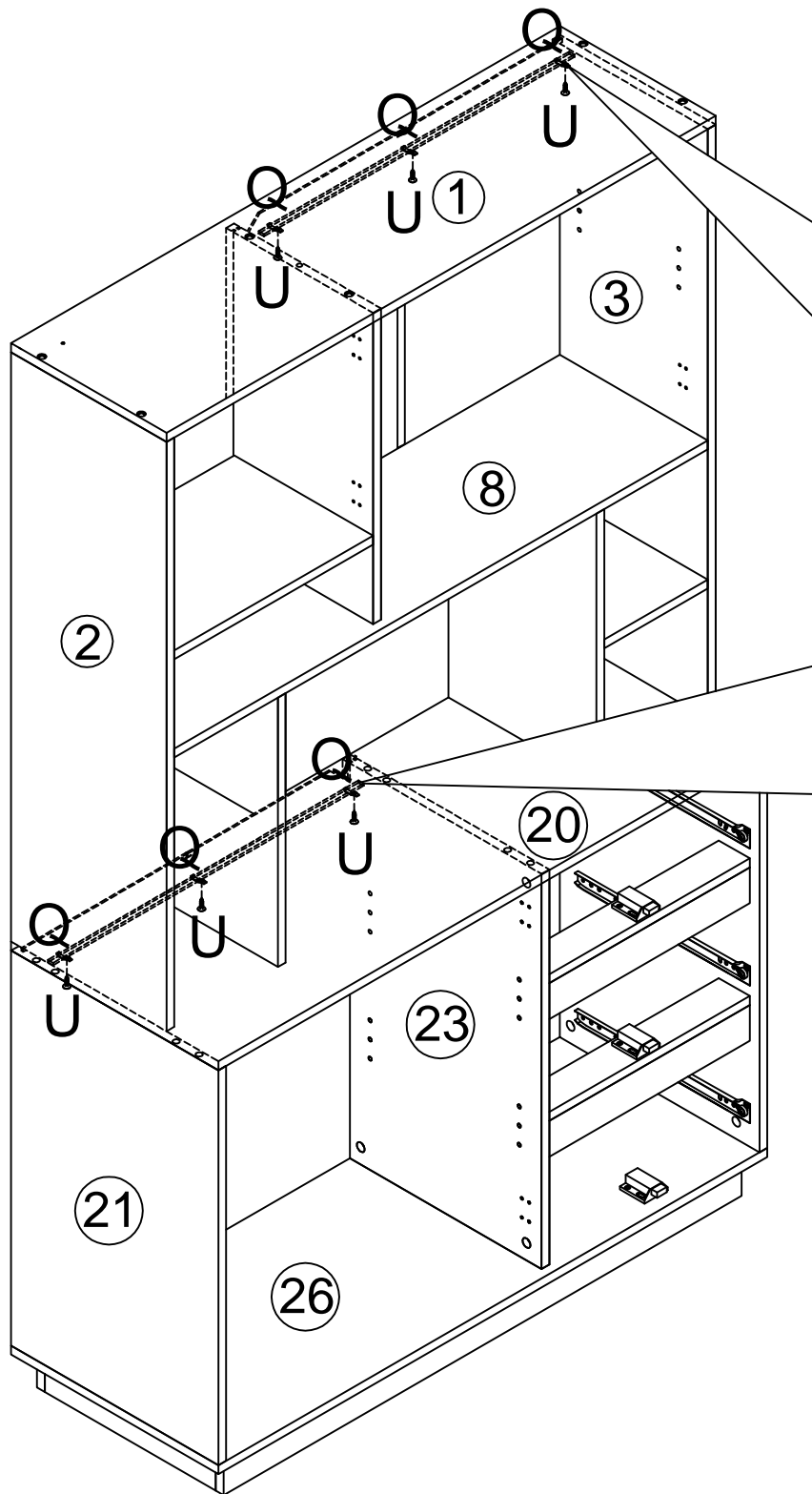

36.

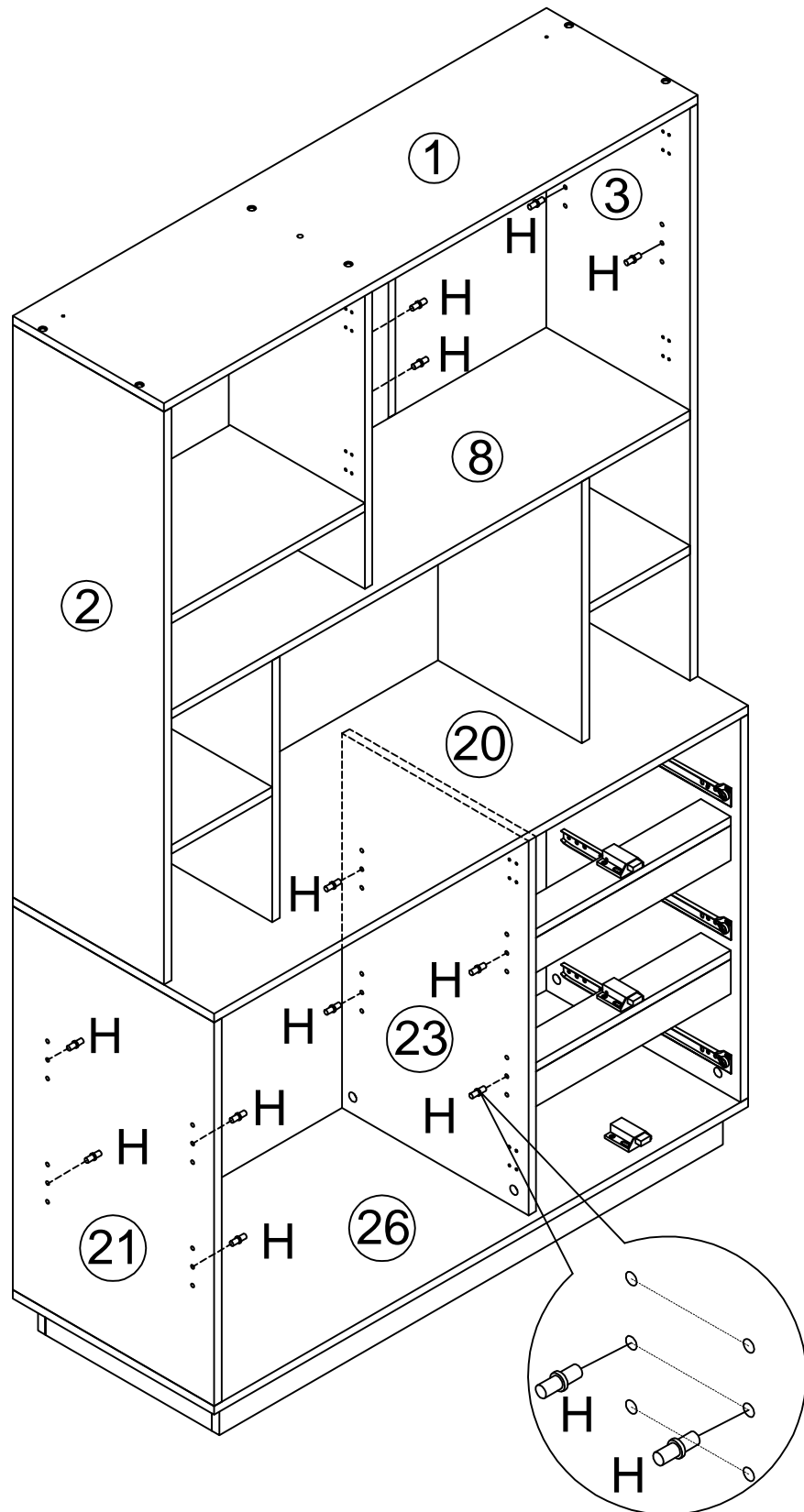

37.

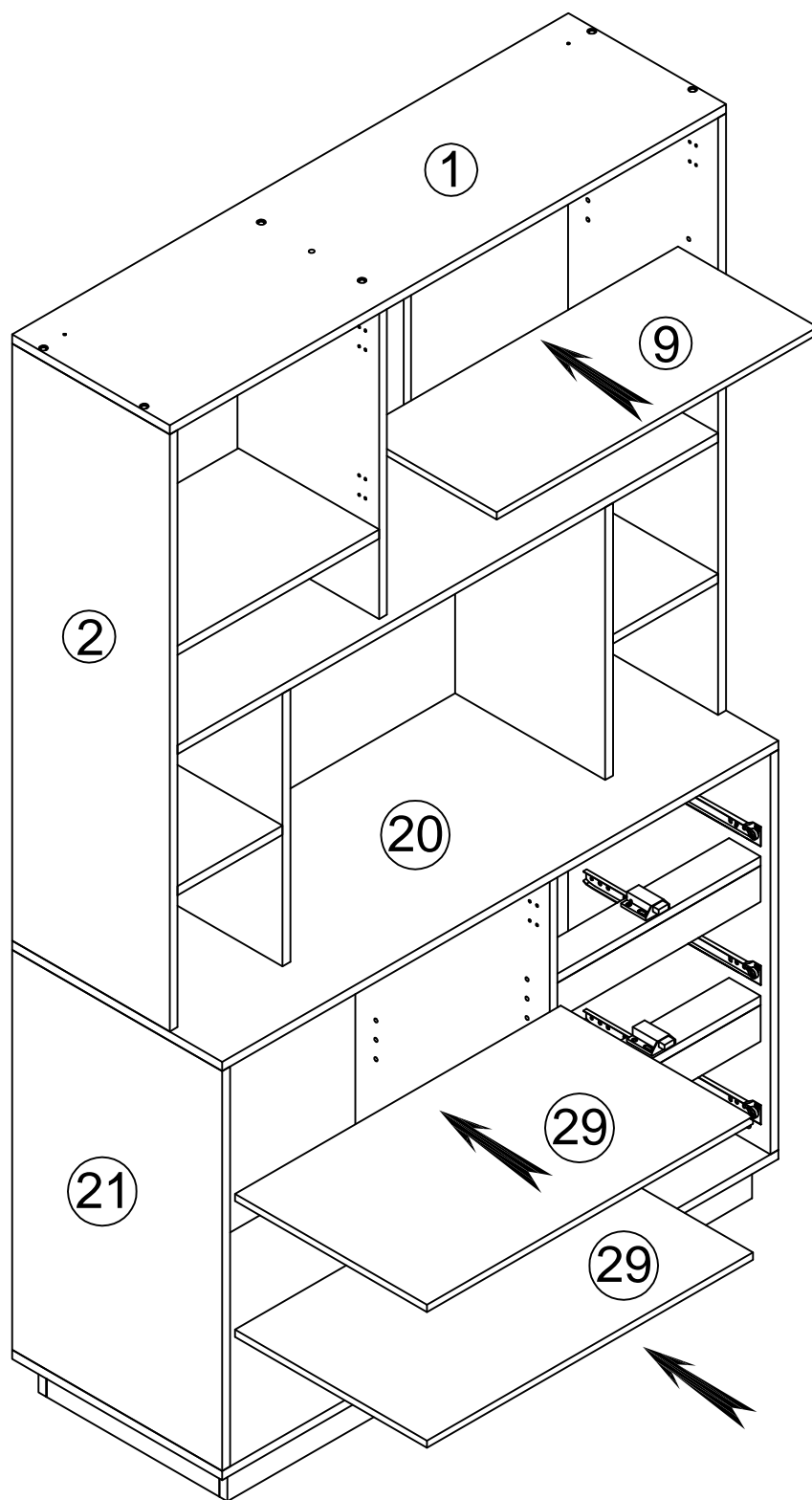

38.

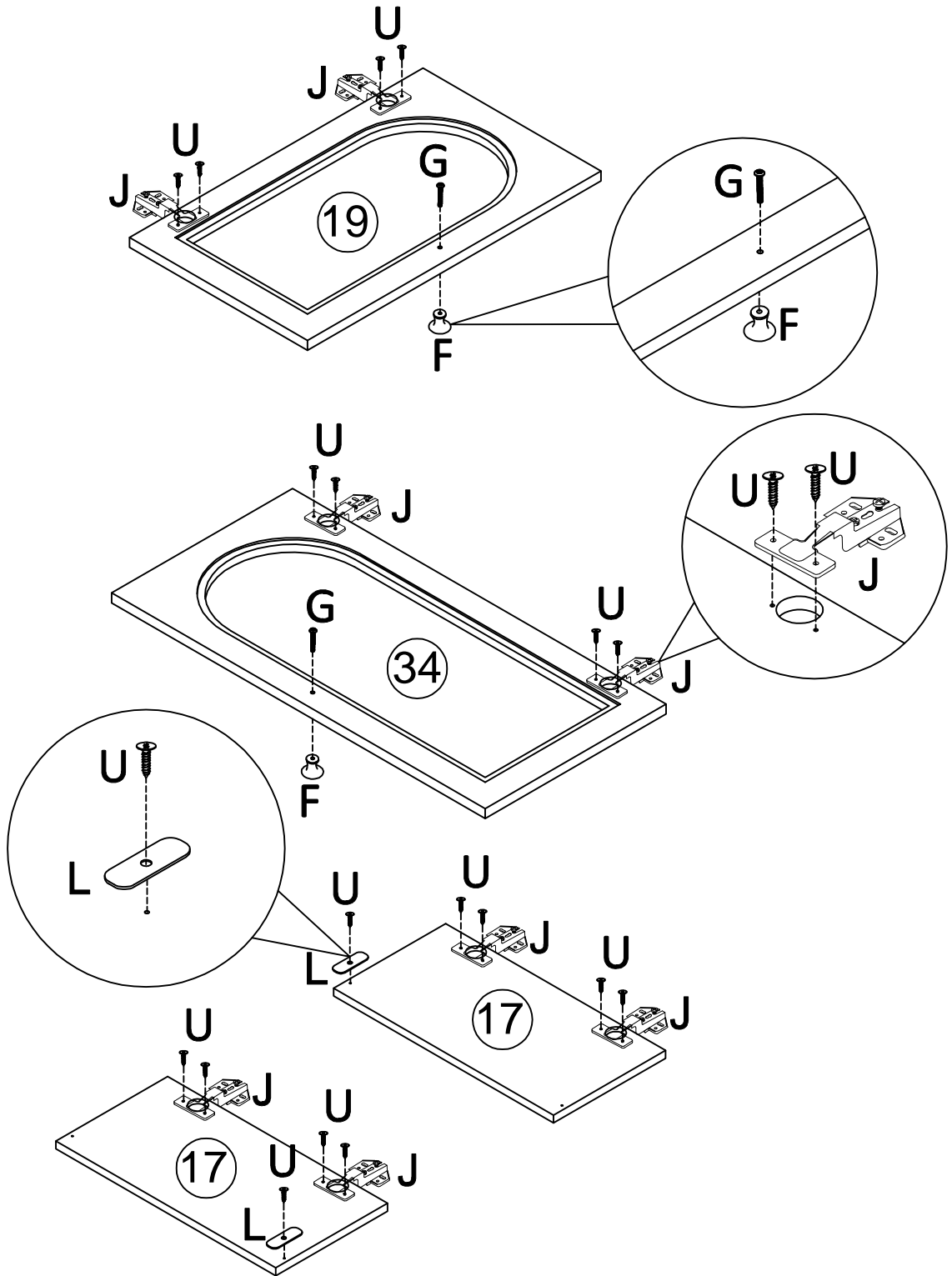

F*2	G*2	J*8	L*2	U*18

39.

Note: It is forbidden to install the fixing hole screws first, otherwise it will lead to installation failure!

Remarque : Il est interdit d'installer d'abord les vis du trou de fixation, sinon cela entraînera un échec de l'installation !

Hinweis: Es ist verboten, zuerst die Befestigungslochschauben zu montieren, da dies sonst zu einem Installationsfehler führt!

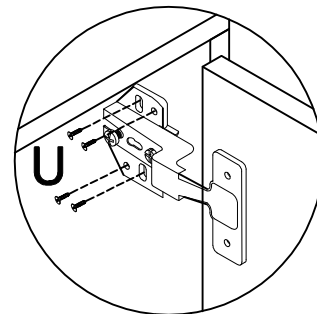
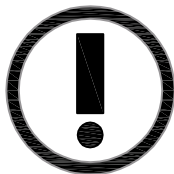
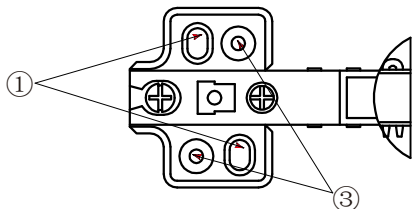

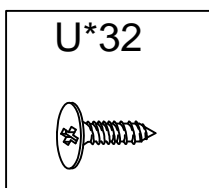
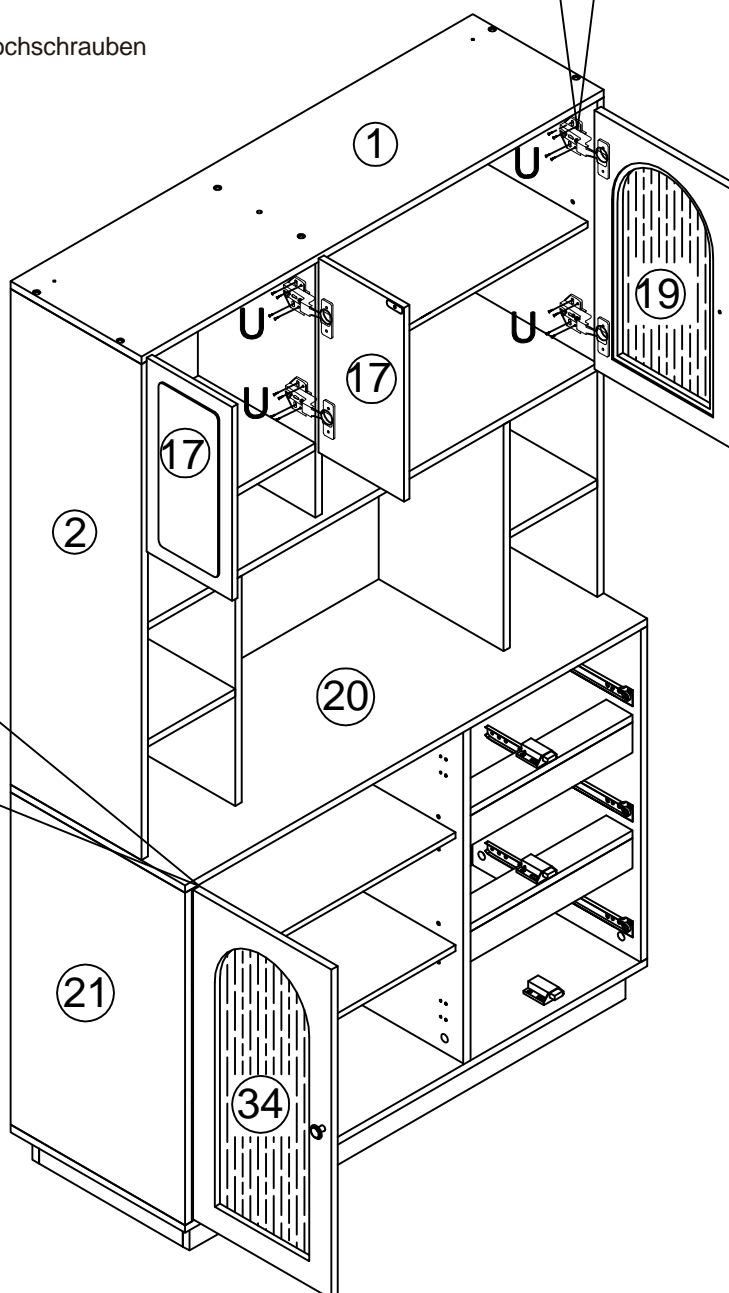
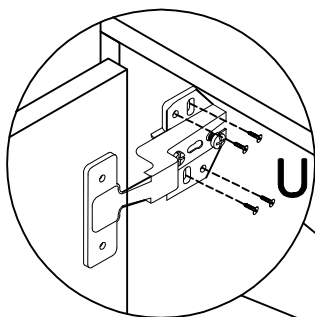

- ① Installez d'abord les vis du trou de réglage
 - ② Mettez la porte dans la bonne position
 - ③ Montieren Sie abschließend die Befestigungslochschauben
- ① Install the adjustment hole screws first
 - ② Get the door in the right position
 - ③ Finally, install the fixing hole screws
- ① Montieren Sie zuerst die Einstellochschauben
 - ② Bringen Sie die Tür in die richtige Position
 - ③ Enfin, installez les vis du trou de fixation

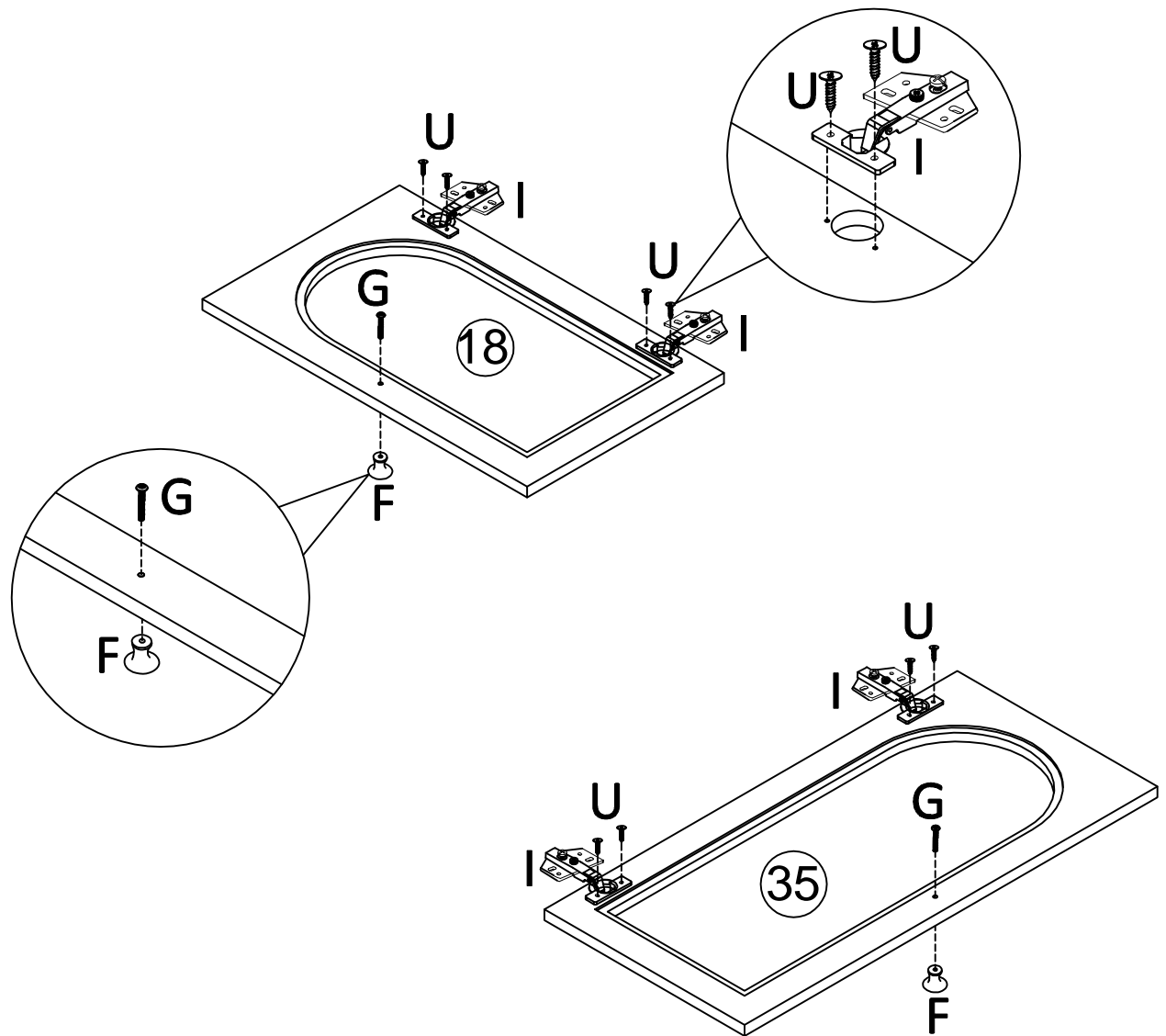

40.

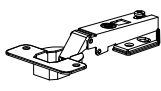
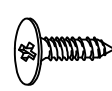

F*2	G*2	I*4	U*8
			

41.

Note: It is forbidden to install the fixing hole screws first, otherwise it will lead to installation failure!

Remarque : Il est interdit d'installer d'abord les vis du trou de fixation, sinon cela entraînera un échec de l'installation !

Hinweis: Es ist verboten, zuerst die Befestigungslochschauben zu montieren, da dies sonst zu einem Installationsfehler führt!

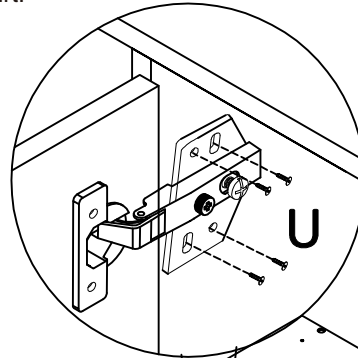
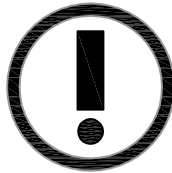
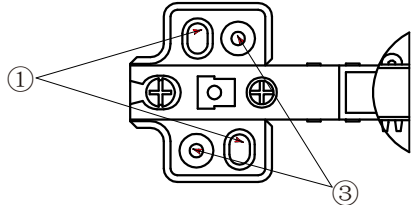

- ① Installez d'abord les vis du trou de réglage
- ② Mettez la porte dans la bonne position
- ③ Montieren Sie abschließend die Befestigungslochschauben
- ① Install the adjustment hole screws first
- ② Get the door in the right position
- ③ Finally, install the fixing hole screws
- ① Montieren Sie zuerst die Einstellochschauben
- ② Bringen Sie die Tür in die richtige Position
- ③ Enfin, installez les vis du trou de fixation

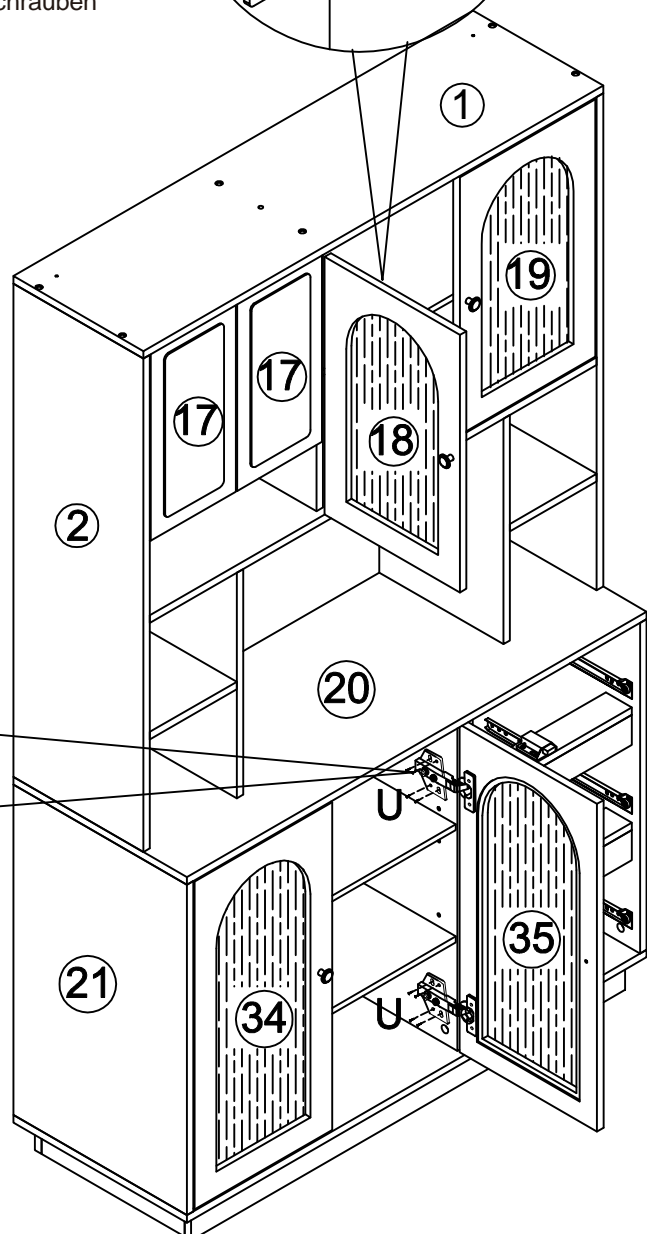
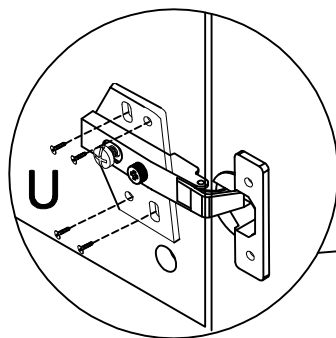

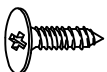

U*16

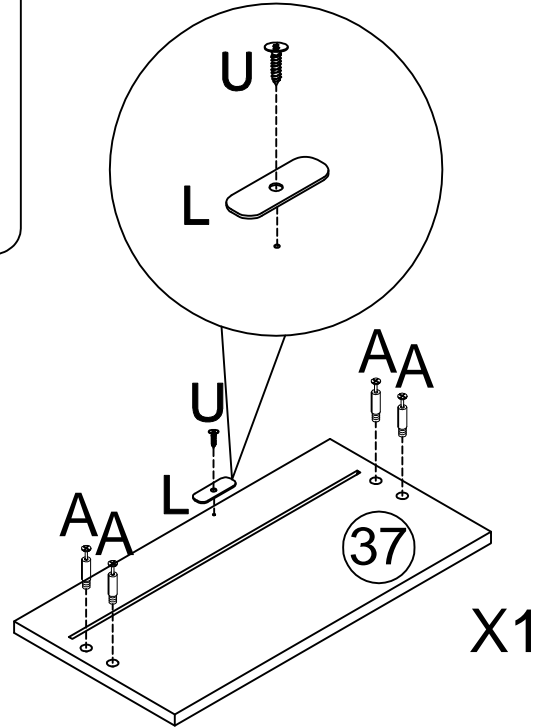
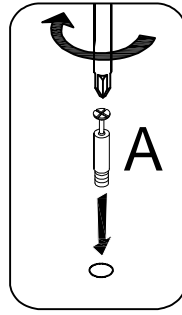
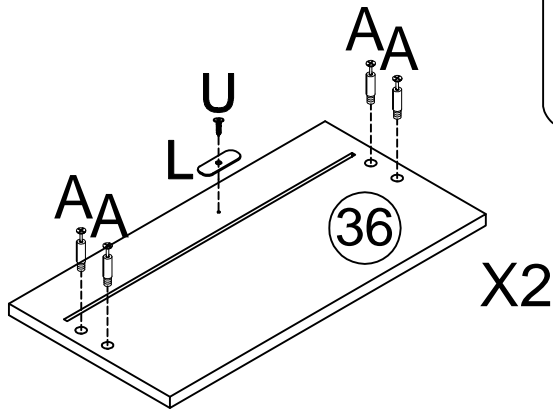

42.

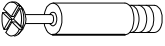

A*12	L*3	U*3
		

43.

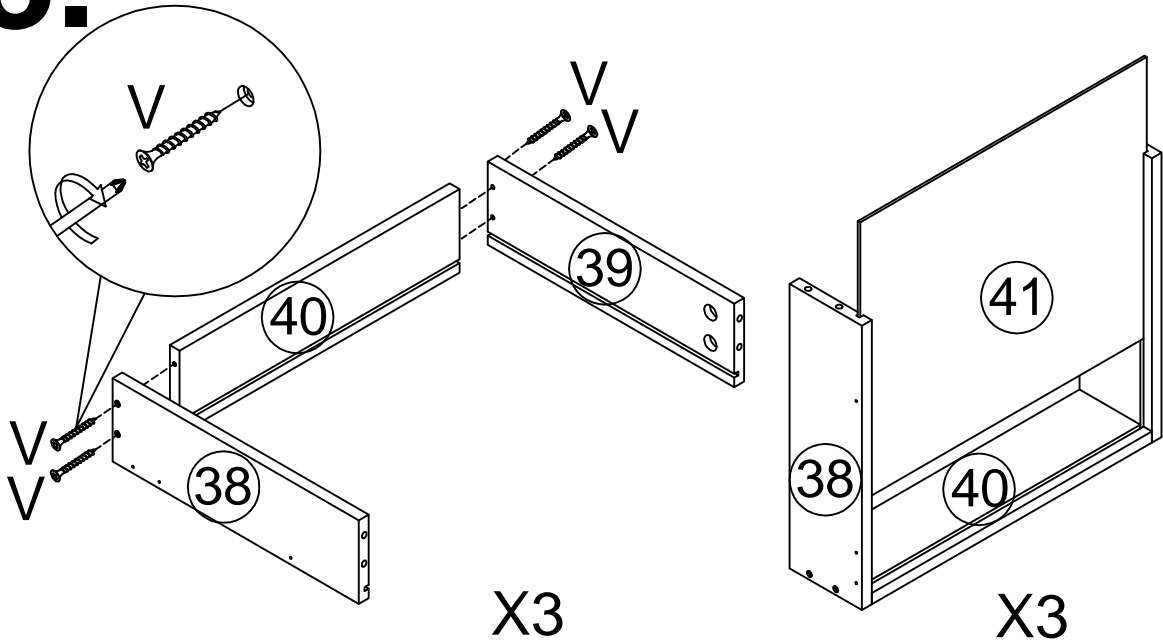

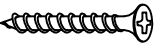
V*12

44.

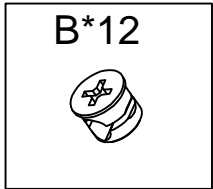
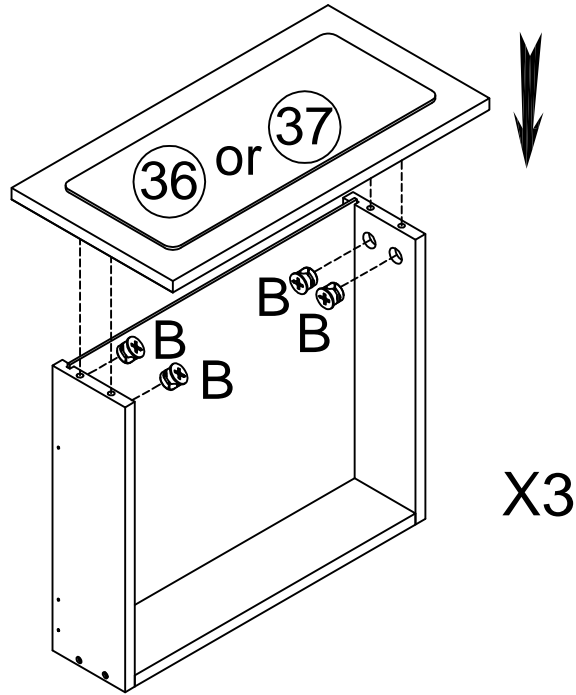

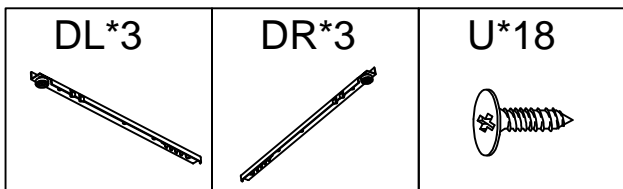
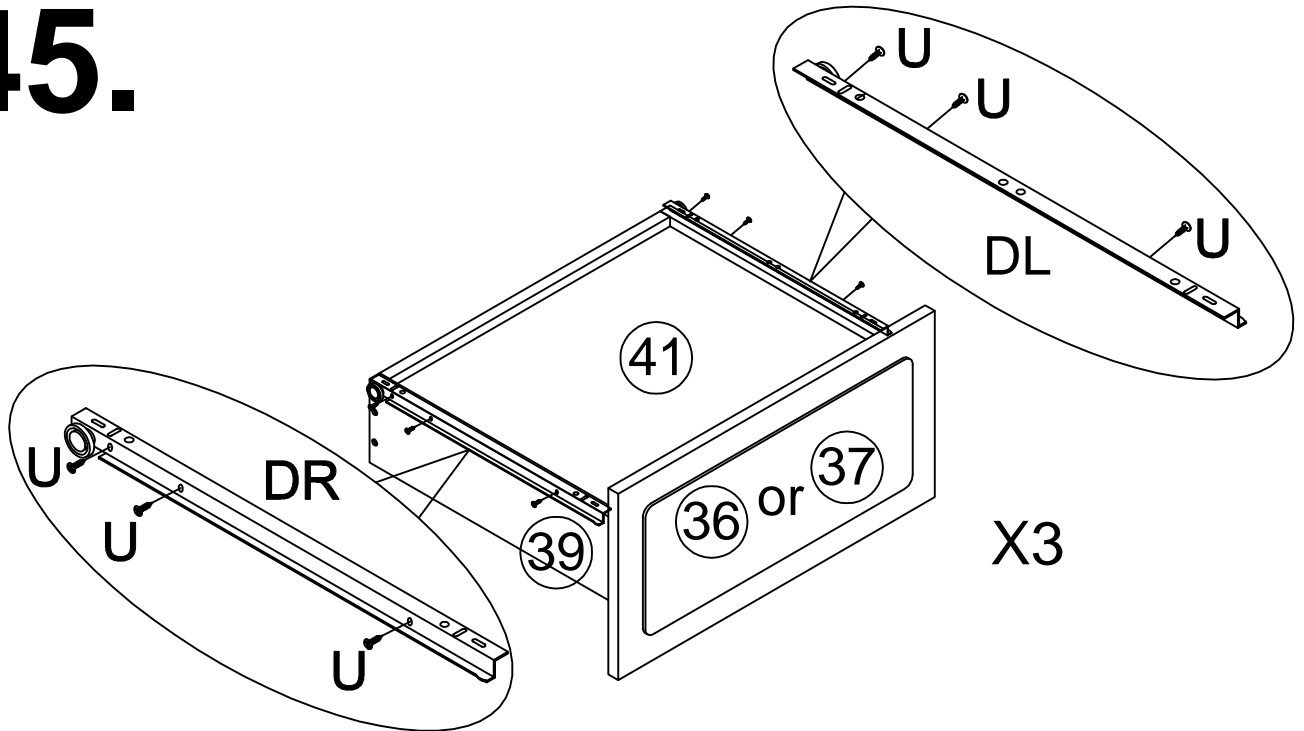

45.

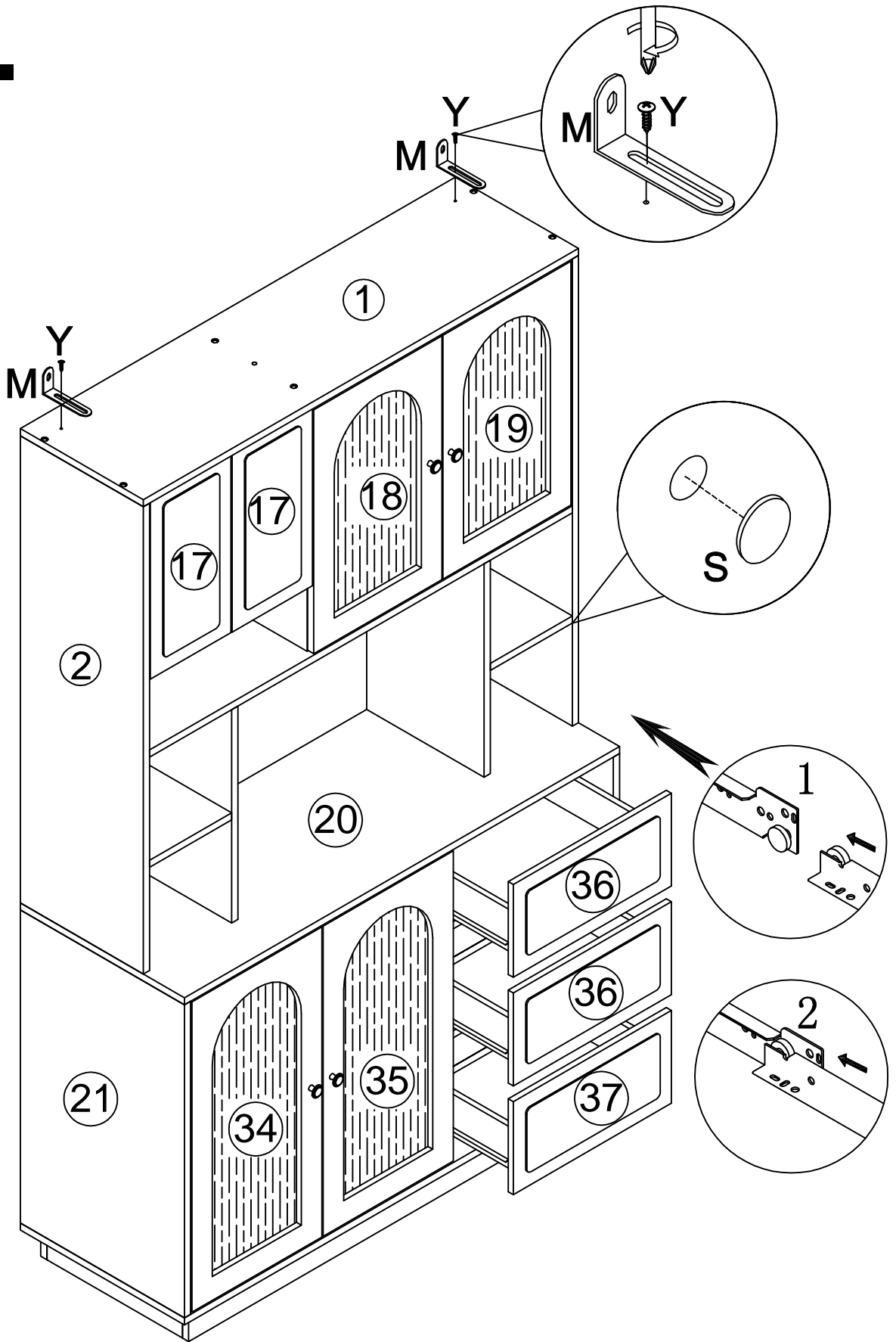

46.

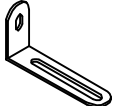

M*2	S*66	Y*2
		

47.

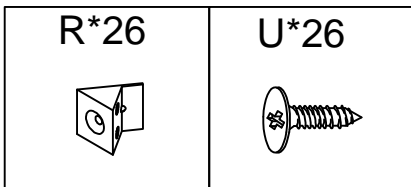
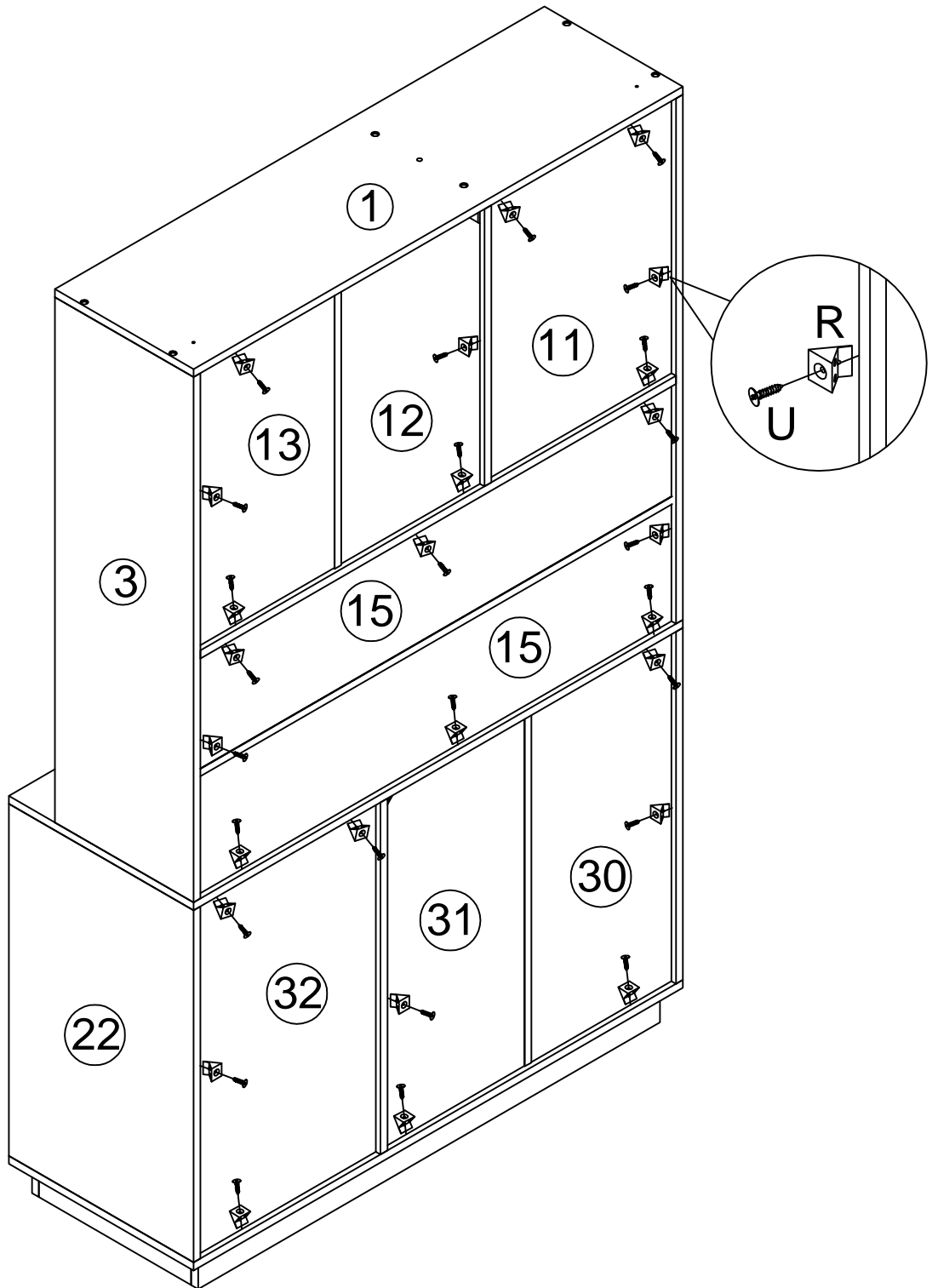

48.

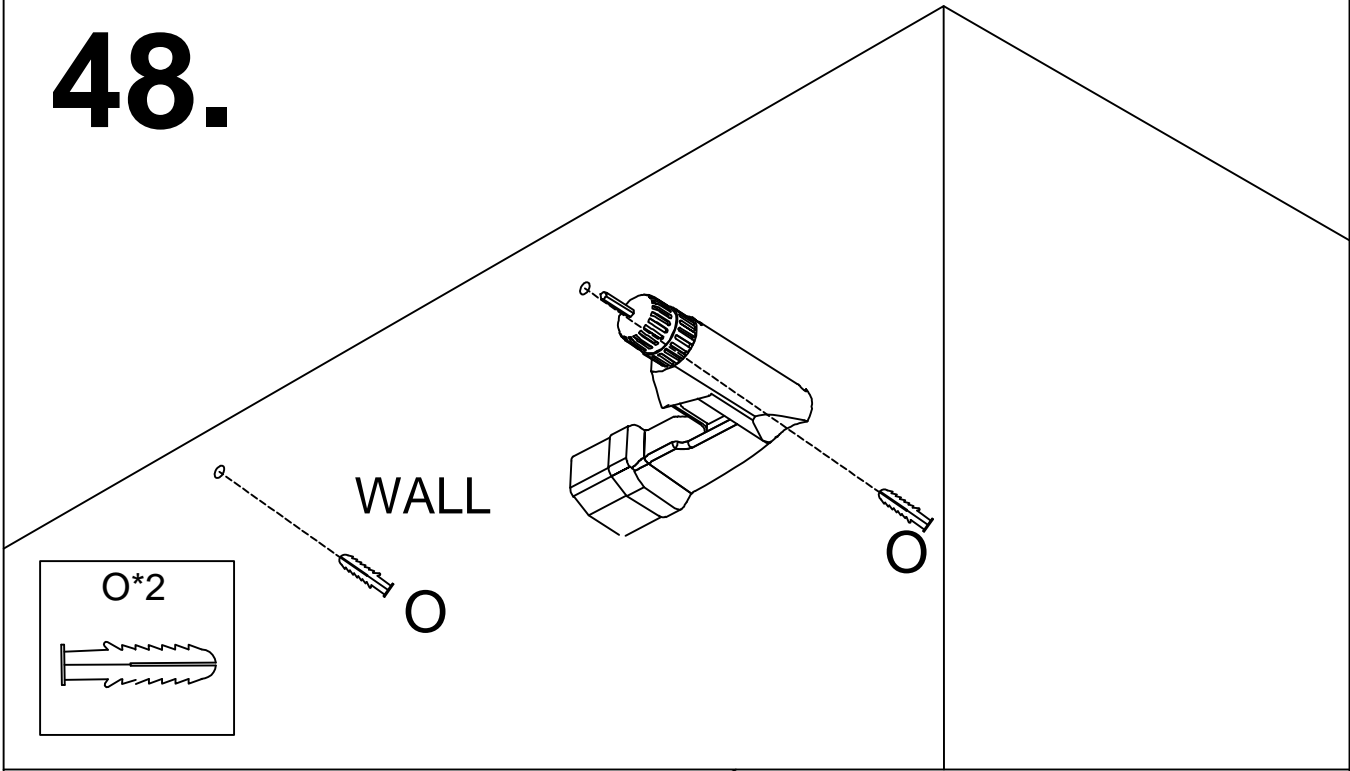

49.

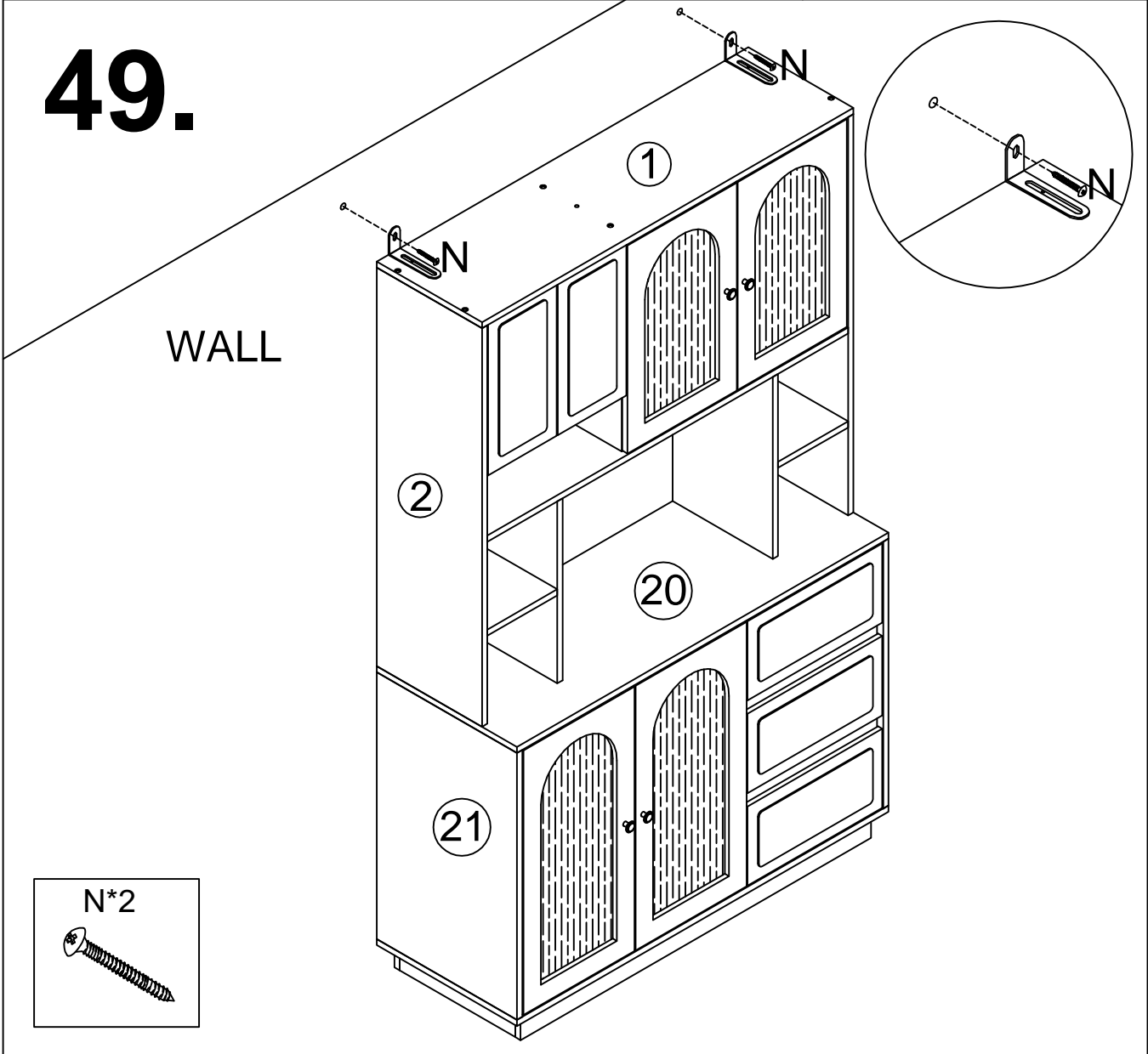

50.

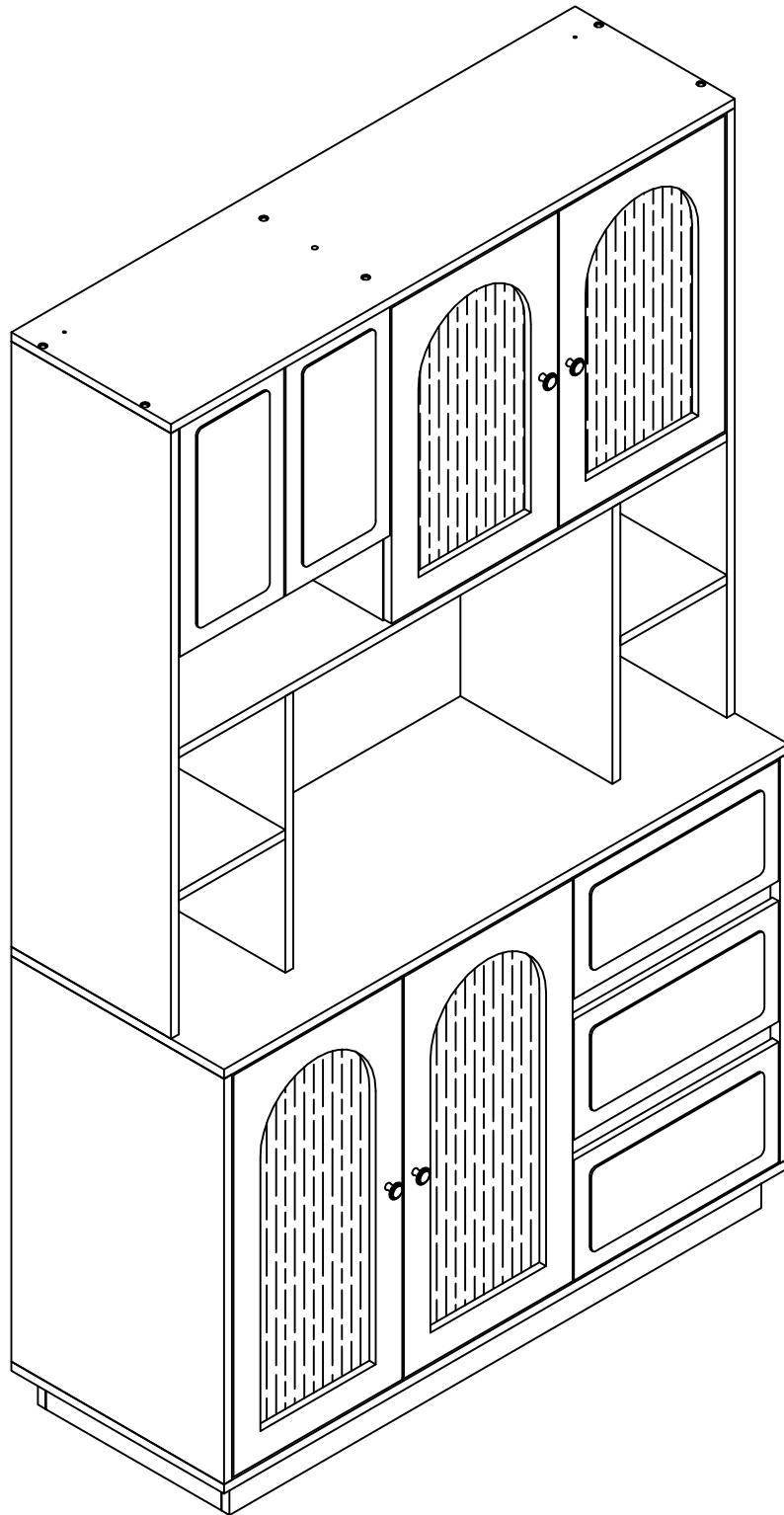

CERTIFICATE OF COMPLIANCE

No.: AiTSZ-250710061C-C01

Product: 5050 RGB LED Strip Lights with Bluetooth App Controller
Trade Mark: N/A
Model: LED 5050 RGB
Applicant: Shenzhen Pinchengxin Technology Co., Ltd
Address: 3rd floor, 8 building Yuanling industrial zon, No. 39 Yuanlingcun road,Shiyan street, Bao'an district, Shenzhen
Manufacture: Shenzhen Pinchengxin Technology Co., Ltd
Address: 3rd floor, 8 building Yuanling industrial zon, No. 39 Yuanlingcun road,Shiyan street, Bao'an district, Shenzhen

The test sample of product has passed the test according to requirements of the following standards:

Standard(s):	Test report(s) No.:
EN 55032:2015+A11:2020 EN 55035:2017+A11:2020	AiTSZ-250710061CE1

Based on the voluntary assessment of the product sample and technical file, we confirm that the above-mentioned product meets the essential requirements of the Electromagnetic Compatibility (EMC) Directive 2014/30/EU.

The CE mark as show below can be used, under the responsibility of the manufacturer or the importer, after completion of an EC declaration of conformity and follow the CE mark usage rules.



Approved by/Date:

Allen Wang

Allen.Wang

Jul. 23, 2025



The statement is based on a single evaluation of one sample of above mentioned products. It does not imply an assessment of the whole production and does not permit the use of the test lab's logo.

Guangdong Asia Hongke Test Technology Limited

B1/F, Building 11, Junfeng Industrial Park, Chongqing Road, Heping Community, Fuhai Street, Bao'an District, Shenzhen, Guangdong, China

www.aitek.org.cn

E-mail:info@aitek.org.cn



CERTIFICATE OF COMPLIANCE

No.: AiTSZ-250710061C-C01

Product: 5050 RGB LED Strip Lights with Bluetooth App Controller
Trade Mark: N/A
Model: LED 5050 RGB
Applicant: Shenzhen Pinchengxin Technology Co., Ltd
Address: 3rd floor, 8 building Yuanling industrial zon, No. 39 Yuanlingcun road,Shiyan street, Bao'an district, Shenzhen
Manufacture: Shenzhen Pinchengxin Technology Co., Ltd
Address: 3rd floor, 8 building Yuanling industrial zon, No. 39 Yuanlingcun road,Shiyan street, Bao'an district, Shenzhen

The test sample of product has passed the test according to requirements of the following standards:

	Standard(s):	Test report(s) No.:
Article 3.1a)	EN IEC 62368-1:2020+A11:2020	AiTSZ-250710061S
	EN 62479: 2010 EN 50663: 2017	AiTSZ-250710061CW3
Article 3.1b)	ETSI EN 301 489-1 V2.2.3 (2019-11) ETSI EN 301 489-17 V3.2.4 (2020-09)	AiTSZ-250710061CW1
Article 3.2)	ETSI EN 300 328 V2.2.2 (2019-07)	AiTSZ-250710061CW2

Based on the voluntary assessment of the product sample and technical file, we confirm that the above-mentioned product meets the essential requirements of the Radio Equipment Directive (RED) 2014/53/EU.

The CE mark as show below can be used, under the responsibility of the manufacturer or the importer, after completion of an EC declaration of conformity and follow the CE mark usage rules.



Approved by/Date:

Sean She

July 23, 2025

Sean She



The statement is based on a single evaluation of one sample of above mentioned products. It does not imply an assessment of the whole production and does not permit the use of the test lab's logo.

Guangdong Asia Hongke Test Technology Limited

B1/F, Building 11, Junfeng Industrial Park, Chongqing Road, Heping Community, Fuhai Street, Bao'an District, Shenzhen, Guangdong, China

www.aitek.org.cn

E-mail: info@aitek.org.cn



Certificate of Compliance

Certificate No.: AITSZ-250710061RC09

The EUT described above has been consolidated by us and found in compliance with the council RoHS 2.0 Directive(EU)2015/863and(EU)2017/2102 amending Annex I to Directive2011/65/EU.

Applicant : Shenzhen Pinchengxin Technology Co., Ltd
Address : 3rd floor, 8 building Yuanling industrial zon, No. 39 Yuanlingcun road, Shiyang street, Bao'an district, Shenzhen
Manufacturer : Shenzhen Pinchengxin Technology Co., Ltd
Address : 3rd floor, 8 building Yuanling industrial zon, No. 39 Yuanlingcun road, Shiyang street, Bao'an district, Shenzhen
Product : 5050 RGB LED Strip Lights with Bluetooth App Controller
Model No. : LED 5050 RGB
Trade mark : N/A
Test Report No. : AITSZ-250710061R

Test Standards

IEC 62321-3-1: 2013
IEC 62321-4:2013+AMD1:2017 CSV
IEC 62321-5:2013
IEC 62321-6:2015
IEC 62321-7-1:2015
IEC 62321-7-2:2017
IEC 62321-8:2017

RoHS

Lizhen

Lizhen

Date: Jul.18, 2025



The statement is based on a single evaluation of one sample of above mentioned products. It does not imply an assessment of the whole production and does not permit the use of the test lab logo.



Guangdong Asia Hongke Test Technology Co.,Ltd.

B1/F, Building 11, Junfeng Industrial Park, Chongqing Road, Heping Community, Fuhai Street, Bao'an District, Shenzhen, Guangdong, China

Tel:+86. 0755-23096763

<https://www.aitek.org.cn>

E-mail:info@aitek.org.cn