

Installation sanleitung Installation Instruction Instruction d'installation

SKU:N623P387774/N623P387775

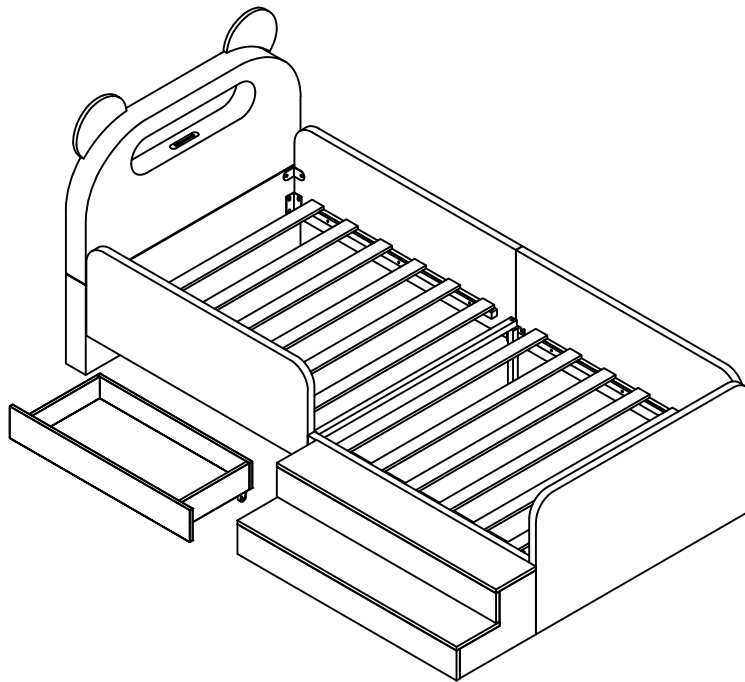

DE:Unser Produkt wird Ihnen in 2 Paketen geliefert. Die Lieferzeiten dieser 2 Pakete können abweichen, bitte haben Sie etwas Geduld und vielen Dank für Ihr Verständnis.

UK:Our product will be delivered to you in 2 packages. The delivery times of these 2 packages may differ, please be patient and thank you for your understanding.

FR:Notre produit vous sera livré en 2 colis. Les délais de livraison de ces 2 colis peuvent différer, soyez patient et merci pour votre compréhension.



English

IMPORTANT FOR GAS LIFT BEDS&MAINTAINCE

- Please place the mattress on top of the bed frame.
- Please do not pull on the strap handles.
- Please press heavily to release the compressed gas.
- Periodically check all screw & fixings to ensure they are secure.
- When moving your product, carefully lift into place.
- Wipe clean with a slightly damp cloth- please do not use abrasive chemicals or bleach.
- Do NOT allow children to operate the lift mechanism.
- Do NOT allow children near the lift base when operating the mechanism.
- Do NOT stand inside the bed or the internal storage base.
- Do NOT overload the internal storage base.
- DO NOT jump on the product or any of its parts.

Deutsch

WICHTIG FÜR GASLIFT-BETTEN&WARTUNG

- Bitte legen Sie die Matratze oben auf den Bettrahmen.
- Bitte ziehen Sie nicht an den Gurtgriffen.
- Bitte drücken Sie kräftig, um das komprimierte Gas freizusetzen.
- Überprüfen Sie regelmäßig alle Schrauben und Befestigungen, um sicherzustellen, dass sie sicher sind.
- Wenn Sie Ihr Produkt bewegen, heben Sie es vorsichtig an seinen Platz.
- Mit einem leicht feuchten Tuch abwischen - bitte keine scheuernden Chemikalien oder Bleichmittel verwenden.
- Erlauben Sie Kindern NICHT, den Hebemechanismus zu bedienen.
- Lassen Sie Kinder NICHT in die Nähe des Liftsockels, wenn Sie den Mechanismus bedienen.
- Stellen Sie sich NICHT in das Bett oder in die Innenablage.
- Überlasten Sie den internen Liftsockel NICHT.
- Springen Sie NICHT auf das Produkt oder eines seiner Teile.

Français

IMPORTANT POUR LES LITS À RELEVAGE DE GAZ&MAINTENANCE

- Veuillez placer le matelas sur le dessus du cadre de lit.
- Ne tirez pas sur les poignées de la sangle.
- Appuyez fortement pour libérer le gaz comprimé.
- Vérifiez régulièrement que toutes les vis et fixations sont bien en place.
- Lorsque vous déplacez votre produit, soulevez-le avec précaution pour le mettre en place.
- Nettoyez avec un chiffon légèrement humide - n'utilisez pas de produits chimiques abrasifs ou d'eau de Javel.
- Ne laissez pas les enfants utiliser le mécanisme de levage.
- Ne laissez pas les enfants s'approcher de la base de levage lorsqu'ils actionnent le mécanisme.
- Ne vous tenez PAS à l'intérieur du lit ou de la base de stockage interne.
- Ne surchargez pas la base de stockage interne.
- Ne pas sauter sur le produit ou l'une de ses parties.

Italiano

IMPORTANTE! CONSERVARE PER RIFERIMENTO FUTURO: LEGGERE ATTENTAMENTE

- Deve essere assemblato da un adulto. L'assemblaggio deve essere controllato da un adulto prima dell'uso
- **ATTENZIONE!** Tenere tutte le viti, le piccole parti e i sacchetti di plastica fuori dalla portata dei bambini
- Identificare correttamente tutte le parti prima dell'assemblaggio
- Non utilizzare mai l'articolo se alcune parti sono rotte o mancanti
- In caso di problemi, si prega di contattare il nostro Servizio Post Vendita
- Le istruzioni del produttore devono essere sempre seguite
- Cura: Pulire con un panno morbido e asciutto. In caso di macchie più estese, strofinare accuratamente con una spugna leggermente umida e nonspugna leggermente umida e non abrasiva
- Evitare il rischio di incendio, non collocando i mobili vicino a fonti di accensione o a oggetti caldi
- Non saltare sul letto

Español

¡ IMPORTANTE ! CONSERVELO PARA FUTURAS CONSULTAS: LEA ATENTAMENTE

- Debe ser montado por un adulto. El montaje debe ser comprobado por un adulto antes del uso
- ADVERTENCIA Mantenga todos los tornillos, piezas pequeñas y bolsas de plástico fuera del alcance de los niños.
- Identifique correctamente todas las piezas antes de montarlas
 - Nunca utilice su artículo si alguna de sus piezas está rota o falta
 - Si surge algún problema, póngase en contacto con nuestro Servicio Postventa
 - Las instrucciones del fabricante deben seguirse en todo momento
 - Cuidado: Limpiar con un paño suave y seco. En caso de manchas más grandes, frote cuidadosamente con una esponja no abrasiva ligeramente humedecida.
 - Evite el riesgo de incendio no colocando los muebles cerca de fuentes de ignición u objetos calientes.
 - No saltar sobre la cama.

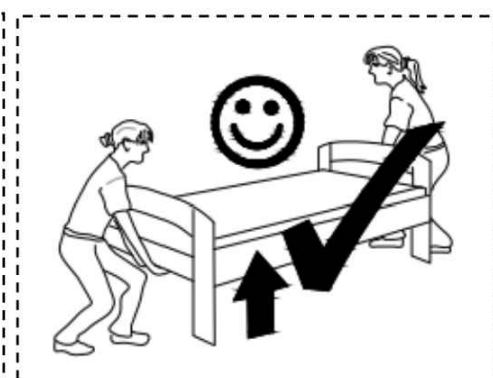



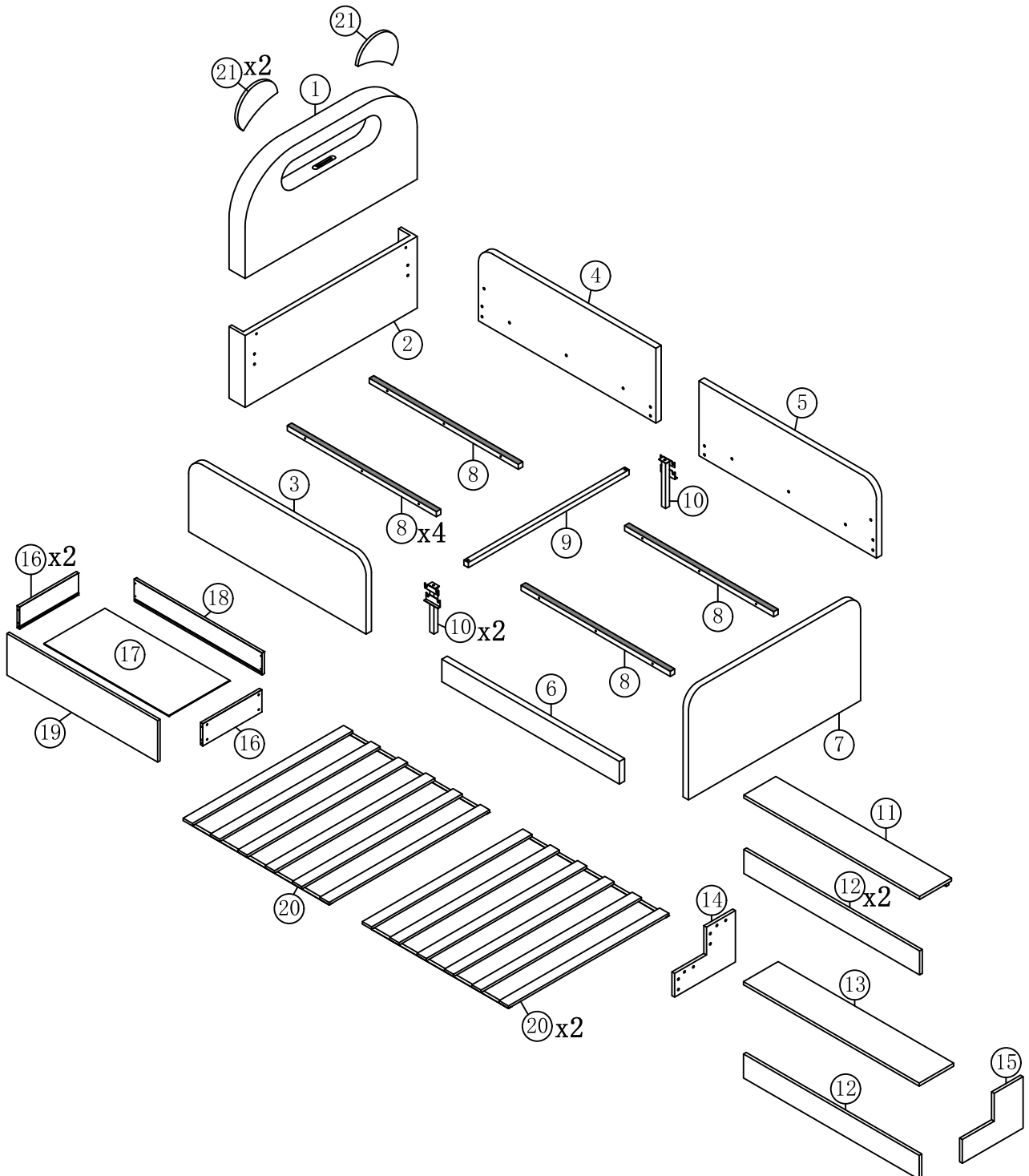

Detail View

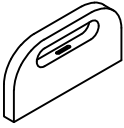
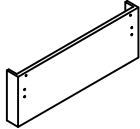
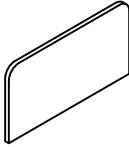
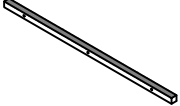
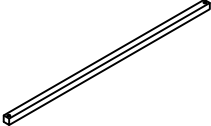

Part List

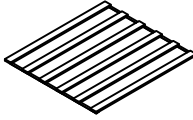
N623P387775





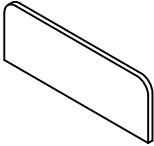
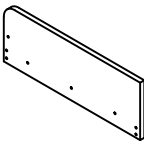
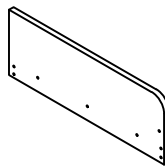
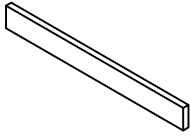
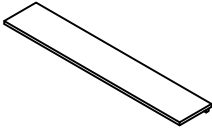
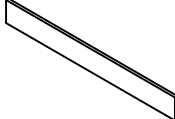
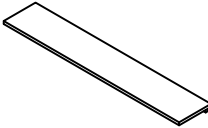
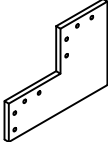
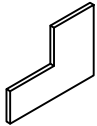
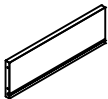
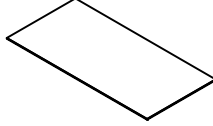
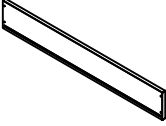
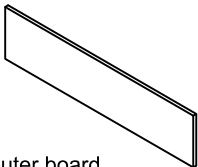





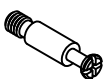

<p>① x1</p>  <p>Head board</p>	<p>② x1</p>  <p>Base board</p>	<p>⑦ x1</p>  <p>Foot board</p>	<p>⑧ x4</p>  <p>Side bar</p>
<p>⑨ x1</p>  <p>Cross bar</p>	<p>⑩ x2</p>  <p>Side rails Support legs</p>	<p>⑳ x2</p>  <p>Slats</p>	<p>㉑ x2</p>  <p>Headboard ears</p>

N623P387774

<p>③ x1</p>  <p>Side rail</p>	<p>④ x1</p>  <p>Side rail</p>	<p>⑤ x1</p>  <p>Side rail</p>	<p>⑥ x1</p>  <p>Side rail</p>
<p>⑪ x1</p>  <p>Step board</p>	<p>⑫ x2</p>  <p>Step board</p>	<p>⑬ x1</p>  <p>Step board</p>	<p>⑭ x1</p>  <p>Step board</p>
<p>⑮ x1</p>  <p>Step board</p>	<p>⑯ x2</p>  <p>Drawer board</p>	<p>⑰ x1</p>  <p>Drawer bottom panel</p>	<p>⑱ x1</p>  <p>Drawer board</p>
<p>⑲ x1</p>  <p>Drawer outer board</p>			

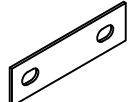
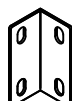
Hardware list

N623P387775

<p>Ax1</p>  <p>Allen Key</p>	<p>Bx4</p>  <p>M8x12mm</p> <p>Bolts</p>	<p>Cx88</p>  <p>M8x16mm</p> <p>Bolts</p>
<p>Dx14</p>  <p>M8x40mm</p> <p>Bolts</p>	<p>Ex8</p>  <p>M3x20mm</p> <p>Nail</p>	<p>Fx8</p>  <p>Drawer fittings</p>
<p>Gx8</p>  <p>Drawer fittings</p>	<p>Hx2</p>  <p>Single-hole iron sheet</p>	<p>Ix3</p>  <p>Four hole iron</p>
<p>Jx2</p>  <p>Four hole iron</p>	<p>Kx1</p>  <p>Two hole iron</p>	<p>Lx12</p>  <p>"7" Connector</p>
<p>Mx6</p>  <p>Little "7" Connector</p>	<p>Nx4</p>  <p>Wheel</p>	<p>Ox1</p>  <p>USB power adapter</p>

DE:Bitte beachten Sie, dass die Formen der Schrauben B und C ähnlich sind. Bitte installieren Sie entsprechend der Anleitung und unterscheiden Sie sie!

UK>Please note that the shapes of screws B and C are similar. Please install according to the instructions and distinguish them!

FR:Notez que les vis B et C ont des formes similaires. Veuillez les installer en suivant les instructions pour les séparer!

DE: Vor dem Einbau die Schrauben in die Löcher stecken und festziehen, aber nicht bis 100%, 70% bis 80% anziehen reicht aus. Schließlich, nachdem alle Schrauben installiert sind, ziehen Sie alle Schrauben auf 100%.

Wenn Sie auf diese Probleme stoßen, wie z. B. Fehlausrichtung der Löcher oder Unfähigkeit, bestimmte Teile zu installieren, überprüfen Sie bitte, ob die Schrauben korrekt verwendet werden und passen Sie die Dichtigkeit der Schrauben an.

UK: Before installation, insert the screws into the holes and tighten them, but do not tighten them to 100%, 70% to 80% is sufficient. Finally, after all screws are installed, tighten all screws to 100%.

If you encounter these issues, such as if the holes cannot be aligned or some parts cannot be installed, please check if the screws are used correctly and adjust the tightness of the screws.

FR: Insérer la vis dans le trou avant la fin de l'assemblage, serrer la vis, mais ne pas serrer à 100%, 70% ~ 80% est correct. Enfin, une fois que toutes les vis sont bien serrées, toutes les vis sont serrées à 100%.

Si vous rencontrez ces problèmes, par exemple si les trous ne sont pas alignés ou si certaines pièces ne peuvent pas être montées, vérifiez que les vis sont utilisées correctement et Ajustez leur serrage.

Attention: Do not tighten the screws before completing the entire installation. If you have any difficulty with the installation process, please feel free to contact us.

Achtung: Ziehen Sie die Schrauben erst fest, wenn die gesamte Installation abgeschlossen ist. Wenn Sie beim Installationsvorgang Schwierigkeiten haben, können Sie sich gerne an uns wenden.

Attention : Ne serrez pas les vis avant d'avoir terminé l'installation. Si vous rencontrez des difficultés lors du processus d'installation, n'hésitez pas à nous contacter.





Step1:

Fix the Base board (2) to the Head board (1) with Bolts C, Four hole iron I and J by using Allen key A.

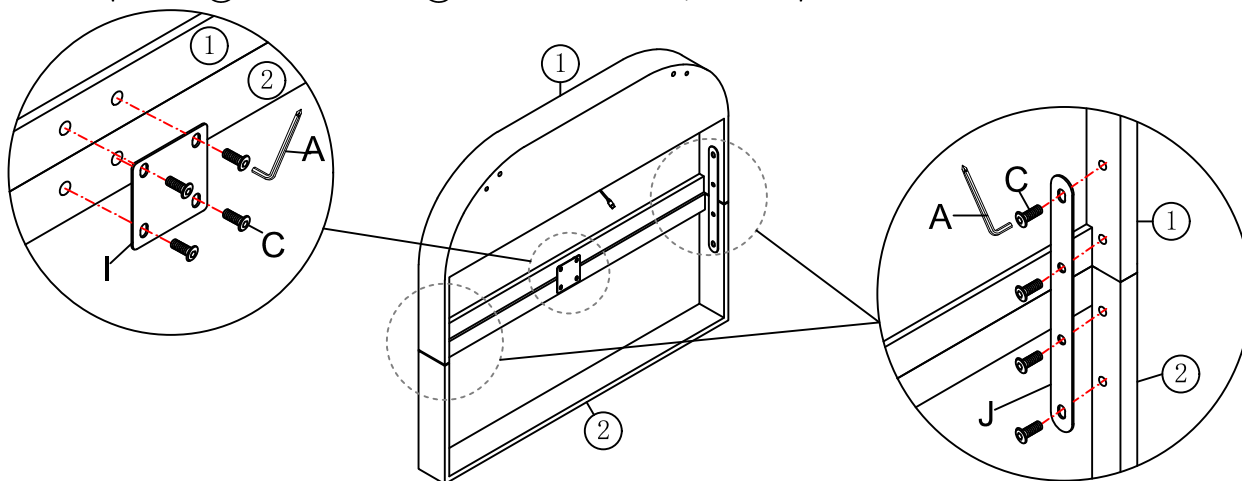
Befestigen Sie die Bodenplatte (2) mit den Schrauben C, dem Vierloch-Eisen I und J mithilfe des Innensechskantschlüssels A an der Kopfleiste (1).

Fixez la plinthe (2) à la tête de lit (1) avec les boulons C, le fer à quatre trous I et J à l'aide de la clé Allen A.



<p>A Allen Key</p> 	<p>C Bolts x 12 M8x16mm</p> 	<p>J Four hole iron x 2</p> 	<p>I Four hole iron x 1</p> 
--	---	---	---



Step2:

Fix the Headboard ears (21) to the Head board (1) with Bolts C and Four hole iron I by using Allen Key A.

Befestigen Sie die Kopfleistenohren (21) mit den Schrauben C und dem Vierloch-Eisen I mithilfe des Innensechskantschlüssels A an der Kopfleiste (1).

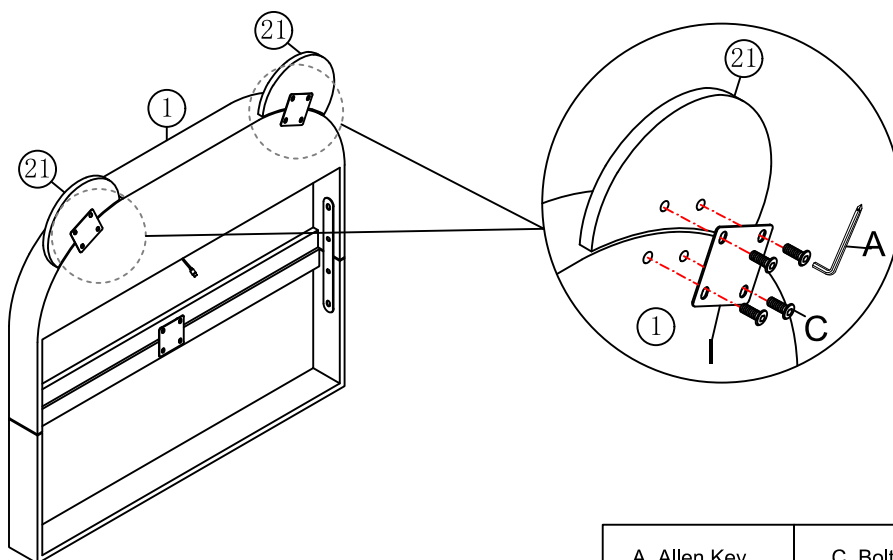
Fixez les oreilles de tête de lit (21) avec les boulons C et la feuille de fer à quatre trous I à l'aide de la clé Allen A à la tête de lit (1).



<p>A Allen Key</p> 	<p>C Bolts x 8 M8x16mm</p> 	<p>I Four hole iron x 2</p> 
---	--	---

Step 3

Fix the Side rail ④ to the Side rail ⑤ with Bolts C , Two hole iron K and Side rails Support legs ⑩ by using Allen Key A.
 Fix the Side rail ③ to the Side rail ⑥ with Bolts C and Side rails Support legs ⑩ by using Allen Key A. Fix Single-hole iron sheet H to Side rail ③ with Bolts C by using Allen Key A.
 Befestigen Sie die Seitenschiene ④ mit den Schrauben C, dem Zweiloch-Eisen K und den Stützfüßen für Seitenschiene ⑩ mithilfe des Innensechskantschlüssels A an der Seitenschiene ⑤. Befestigen Sie die Seitenschiene ③ mit den Schrauben C und den Stützfüßen für Seitenschiene ⑩ mithilfe des Innensechskantschlüssels A an der Seitenschiene ⑥. Befestigen Sie das Einloch-Eisenblech H mit den Schrauben C mithilfe des Innensechskantschlüssels A an der Seitenschiene ③.
 Fixez la traverse latérale ④ avec les boulons C, le fer à deux trous K et les pieds de support pour traverses latérales ⑩ à l'aide de la clé Allen A à la traverse latérale ⑤. Fixez la traverse latérale ③ avec les boulons C et les pieds de support pour traverses latérales ⑩ à l'aide de la clé Allen A à la traverse latérale ⑥. Fixez la feuille de fer à un trou H avec les boulons C à l'aide de la clé Allen A à la traverse latérale ③.

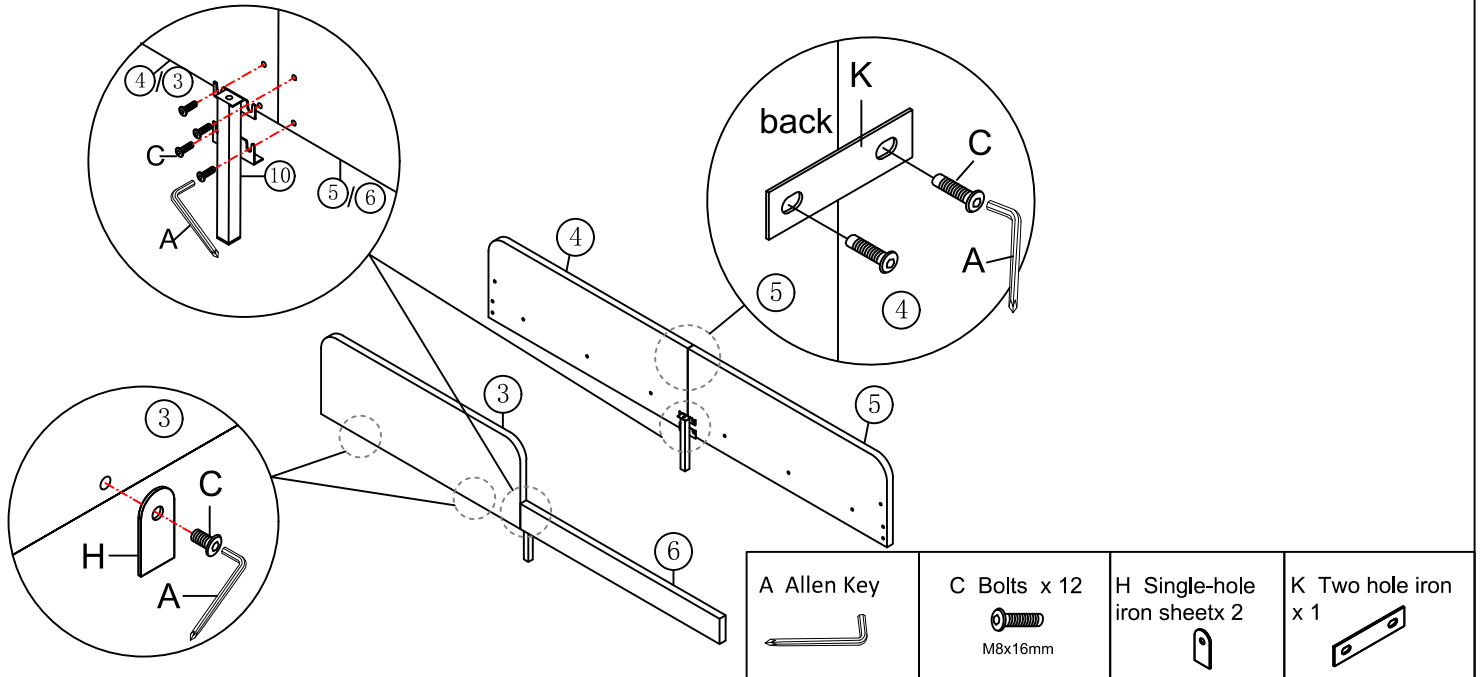

Step 4

Fix the Side rail ③ and ④ to Base board ② with "7" Connector L and Little "7" Connector M, Bolts B and C by using Allen Key A.
 Befestigen Sie die Seitenschiene ③ und ④ mit dem 7-Connector L, dem kleinen 7-Connector M sowie den Schrauben B und C mithilfe des Innensechskantschlüssels A an der Bodenplatte ②.
 Fixez la traverse latérale ③ et ④ avec le connecteur 7 L, le petit connecteur 7 M ainsi que les boulons B et C à l'aide de la clé Allen A à la plinthe ②.

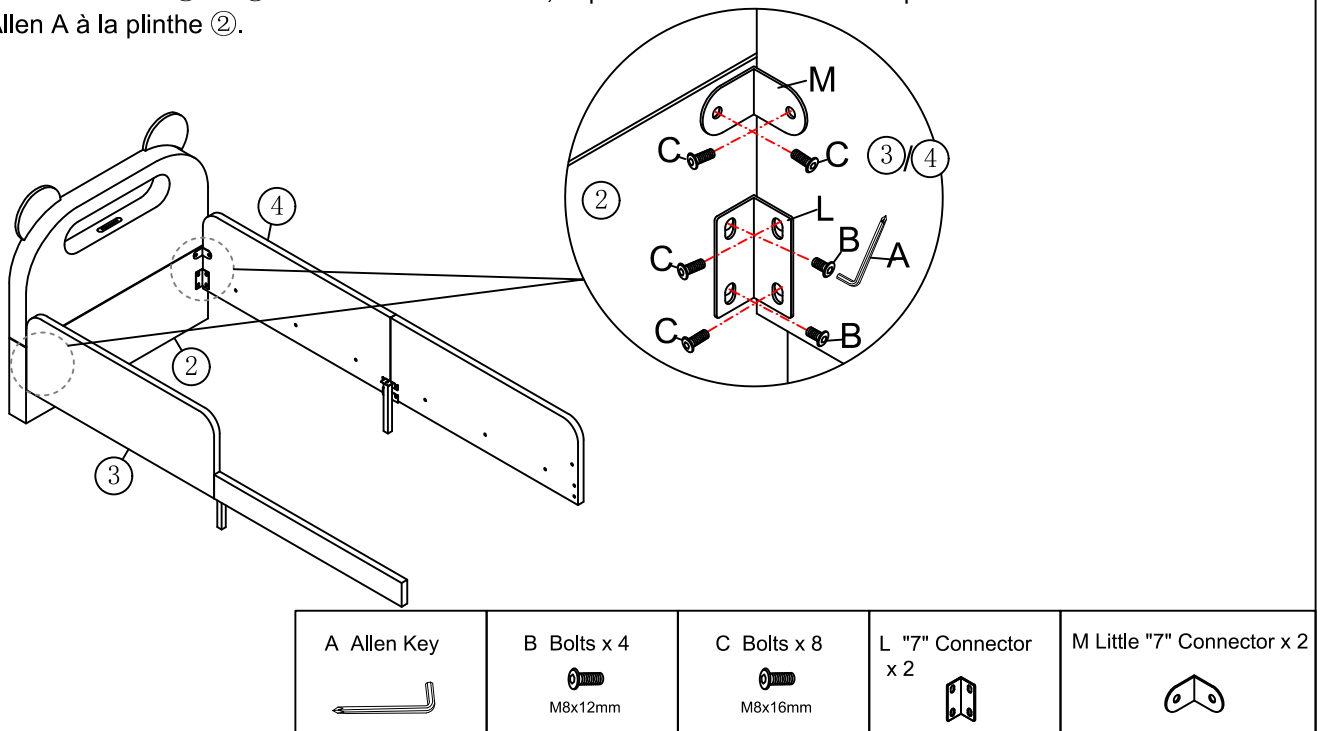





Step 5:

Fix the Foot board (7) to Side rail (5) and (6) with "7" Connector L and Little "7" Connector M and Bolts C by using Allen Key A.

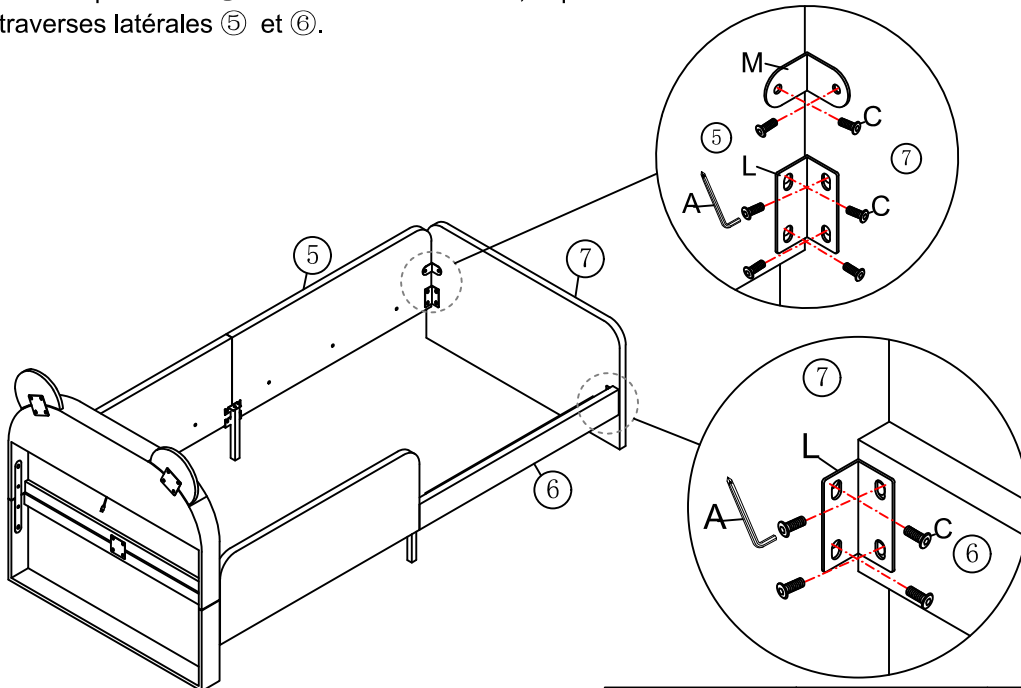
Befestigen Sie die Fußleiste (7) mit dem 7-Connector L, dem kleinen 7-Connector M und den Schrauben C mithilfe des Innensechskantschlüssels A an den Seitenschienen (5) und (6).

Fixez la pied de lit (7) avec le connecteur 7 L, le petit connecteur 7 M et les boulons C à l'aide de la clé Allen A aux traverses latérales (5) et (6).



A Allen Key 	C Bolts x 10 M8x16mm 	L "7" Connector x 2 	M Little "7" Connector x 1 
--	---	---	---



Step 6:

Fix the Side bar (8) to the Side rail (3), (4), (5) and (6) with Bolts D by using Allen key A.

Befestigen Sie die Seitenleiste (8) mit den Schrauben D mithilfe des Innensechskantschlüssels A an den Seitenschienen (3), (4), (5) und (6).

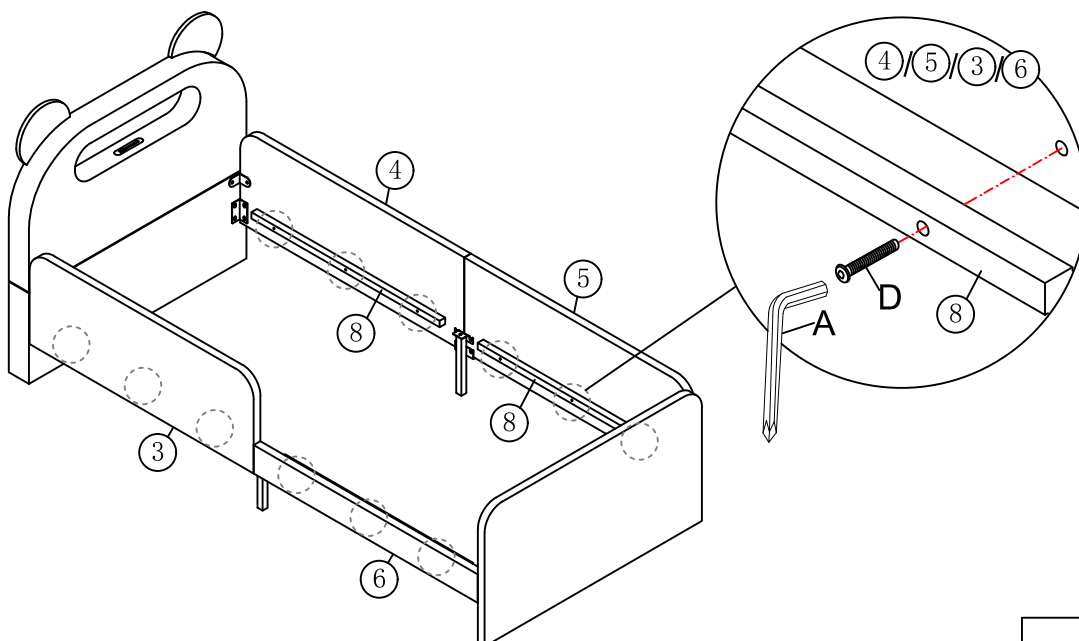
Fixez la barre latérale (8) avec les boulons D à l'aide de la clé Allen A aux traverses latérales (3), (4), (5) et (6).



A Allen Key 	D Bolts x 12 M8x40mm 
--	--

Step 7:

Fix the Cross bar ⑨ to the Side rails support legs ⑩ with Bolts D by using Allen key A.
Befestigen Sie die Querstange ⑨ mit den Schrauben D mithilfe des Innensechskantschlüssels A an den Stützfüßen für Seitenschienen ⑩.
Fixez la barre transversale ⑨ avec les boulons D à l'aide de la clé Allen A aux pieds de support pour traverses latérales ⑩.

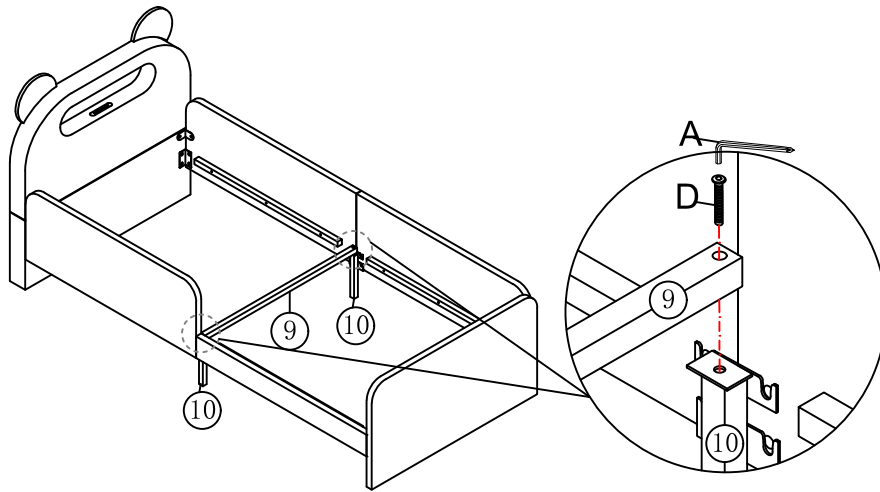

A Allen Key



D Bolts x 2



Step 8:

Put the Slats ⑳ on the Side bar ⑧.
Legen Sie die Latten ⑳ auf die Seitenleiste ⑧.
Posez les lattes ⑳ sur la barre latérale ⑧.

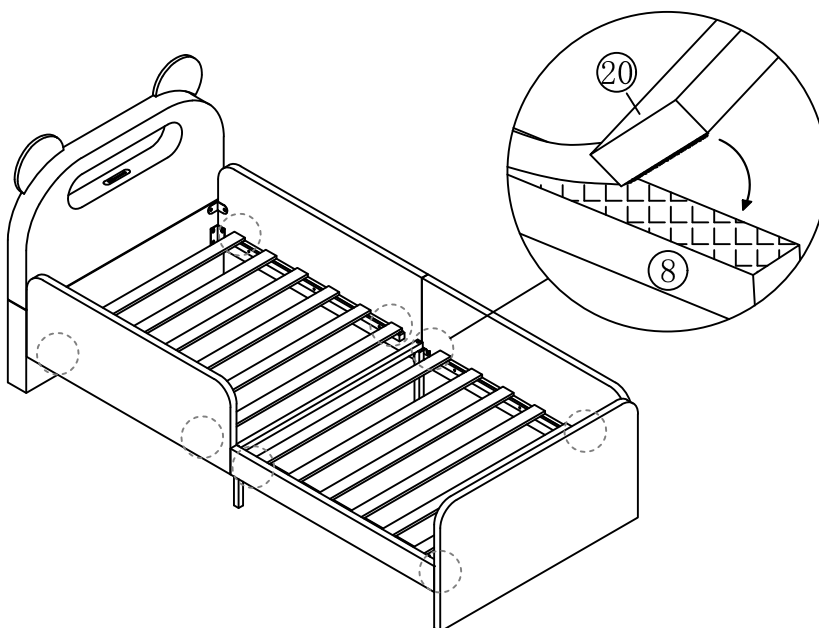

Step 9:

Fix the "7" Connector L to Step board ⑪,⑫,⑬ with Bolts C by using Allen Key A.

Befestigen Sie den 7-Connector L mit den Schrauben C mithilfe des Innensechskantschlüssels A an den Trittplatten ⑪, ⑫, ⑬.

Fixez le connecteur 7 L avec les boulons C à l'aide de la clé Allen A aux plaques de marche ⑪, ⑫, ⑬.

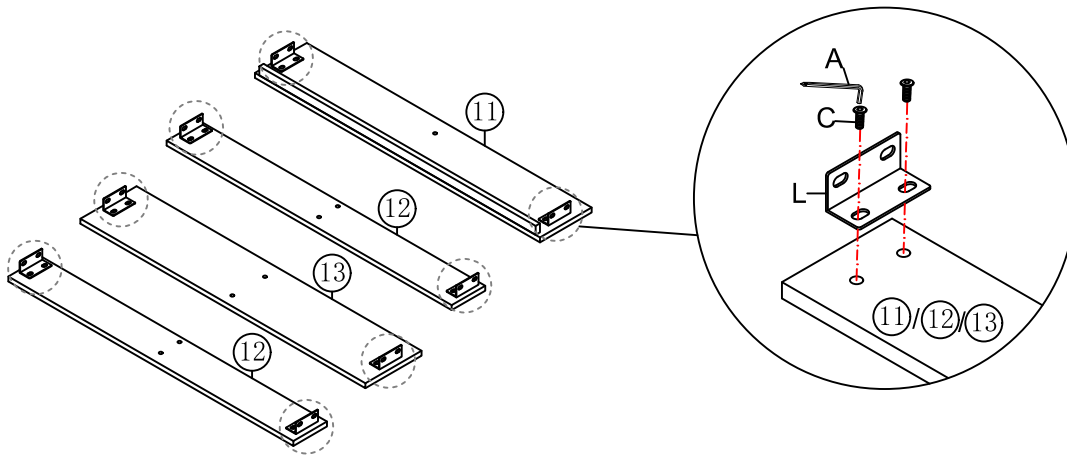

A Allen Key



C Bolts x 16



L "7" Connector
x 8



Step 10:

Fix the Step board ⑭ and ⑮ to the "7" Connector L with Bolts C by using Allen key A .

Befestigen Sie die Trittplatten ⑭ und ⑮ mit den Schrauben C mithilfe des Innensechskantschlüssels A am 7-Connector L.

Fixez les plaques de marche ⑭ et ⑮ avec les boulons C à l'aide de la clé Allen A au connecteur 7 L.

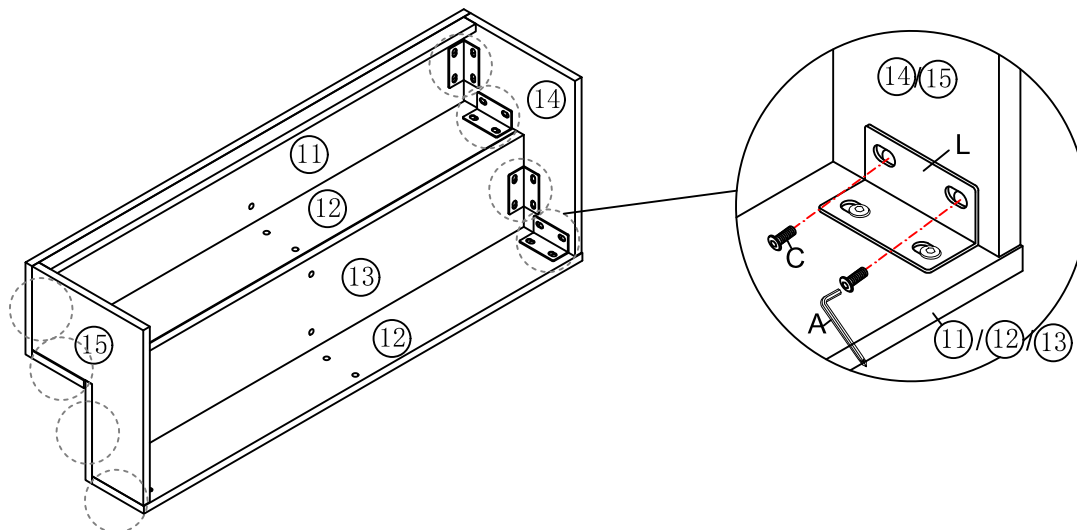

A Allen Key



C Bolts x 16



Step 11:

Fix the Step board ⑪, ⑫, ⑬ together with the Little "7" Connector M and Bolts C by using Allen Key A.

Befestigen Sie die Trittplatten ⑪, ⑫, ⑬ mit dem kleinen 7-Connector M und den Schrauben C mithilfe des Innensechskantschlüssels A gegenseitig.

Fixez les plaques de marche ⑪, ⑫, ⑬ entre elles avec le petit connecteur 7 M et les boulons C à l'aide de la clé Allen A.

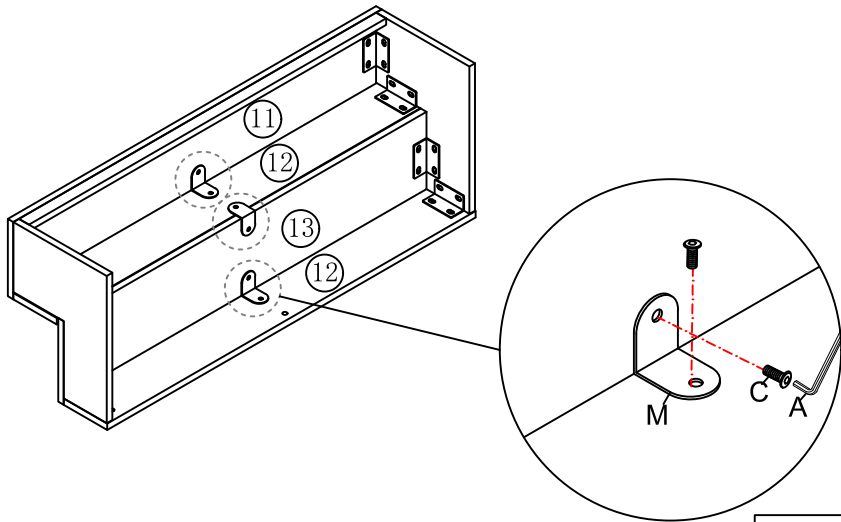

A Allen Key



C Bolts x 6



M "7" Connector
x 3



Step 12:

Place the steps next to the bed.

Stellen Sie die Trittplatten neben das Bett.

Posez les plaques de marche à côté du lit.

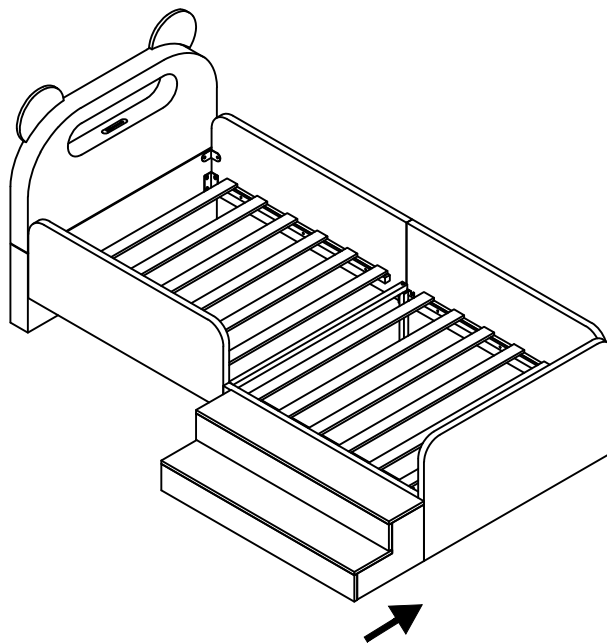

Step 13:





Fix the Drawer fittings F to the Drawer out board (19) and Drawer board (18). Connect Drawer board (16) to (18) and (19) with Drawer Fittings G by using Allen key A. Fix Wheel N to the bottom of the drawers with Nails E by using Allen Key A.

Befestigen Sie die Schubladenscharniere F an der Schubladenaußenplatte (19) und der Schubladenplatte (18).

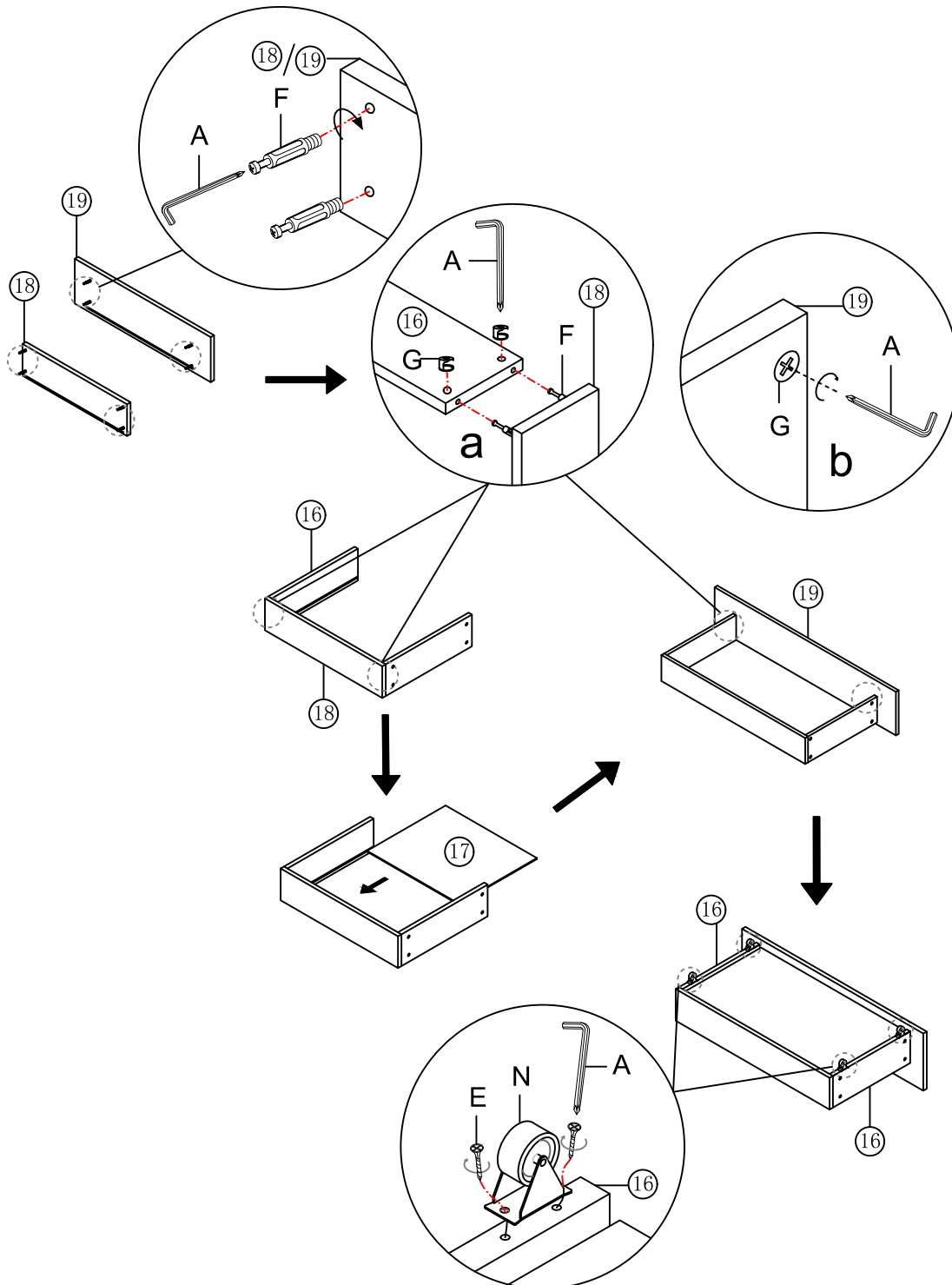
Verbinden Sie die Schubladenplatte (16) mit (18) und (19) mithilfe der Schubladenscharniere G und des Innensechskantschlüssels A. Befestigen Sie die Räder N mit den Nägeln E mithilfe des Innensechskantschlüssels A an der Unterseite der Schubladen.

Fixez les ferrures de tiroir F sur la plaque extérieure de tiroir (19) et la plaque de tiroir (18). Reliez la plaque de tiroir (16) à (18) et (19) à l'aide des ferrures de tiroir G et de la clé Allen A. Fixez les roulettes N avec les clous E à l'aide de la clé Allen A à la partie inférieure des tiroirs.



<p>A Allen Key</p> 	<p>F Drawer fittings x 8</p> 	<p>G Drawer fittings x 8</p> 	<p>E Nails x 8 M3x20mm</p> 	<p>N Wheel x 4</p> 
--	--	--	--	--

Step 14:

Plug the USB power adapter O into the USB port.

Stecken Sie den USB-Netzadapter O in den USB-Anschluss.

Branchez l'adaptateur d'alimentation USB O dans la prise USB.

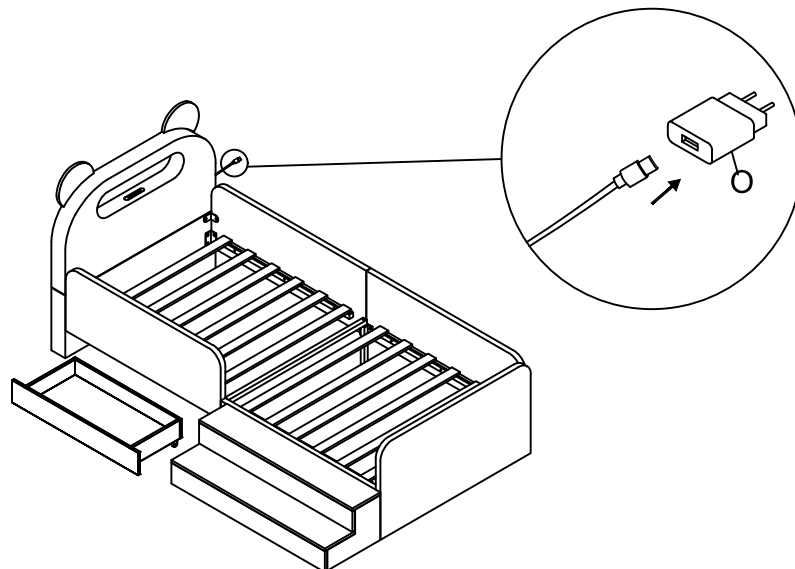

O USB power adapter x 1



Step 15:

Every thing is finished now, please enjoy your bed.

Jetzt ist alles vorbei, bitte genießen Sie Ihr Bett.

Maintenant que c'est fini, s'il vous plaît, profitez de votre lit.

