

N657P420826 N657P420827



Product manual

Gebrauchsanweisung

Manuel du produit

Manual del producto

Manuale del prodotto

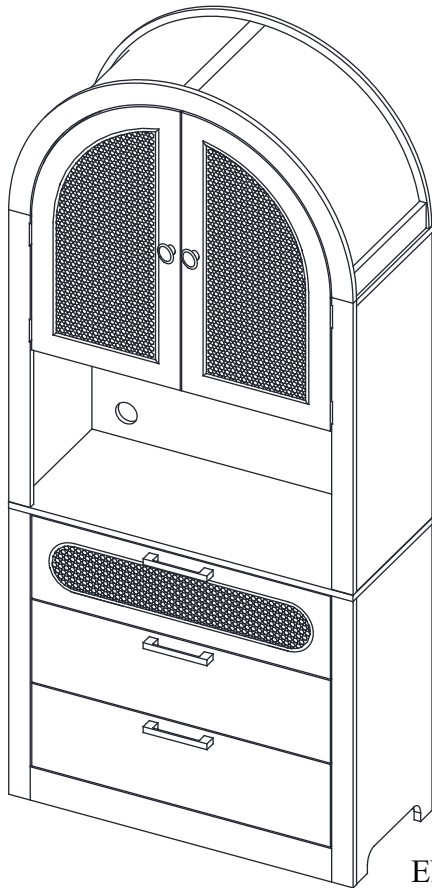

EN:Our product will be delivered to you in 2 packages.
The delivery times of these 2 packages may differ, please be patient and thank you for your understanding

FR:Notre produit vous sera livré en 2 colis. Les délais de livraison de ces 2 colis peuvent différer, soyez patient et merci de votre compréhension.

DE:Unser Produkt wird Ihnen in 2 Paketen geliefert. Die Lieferzeiten dieser 2 Pakete können abweichen, bitte haben Sie etwas Geduld und vielen Dank für Ihr Verständnis

IT:I nostri prodotti vengono trasportati in due pacchetti. I tempi di consegna dei due pacchetti sono diversi: abbiate pazienza e vi ringrazio per la vostra comprensione.

ES:Nuestro producto se entrega en dos paquetes. El tiempo de entrega de estos dos paquetes es diferente. Por favor, sea paciente. Gracias por su comprensión.



FR
Cet appareil,
ses cordons,
et batterie
se recyclent

À DÉPOSER
EN MAGASIN

OU

À DÉPOSER
EN DÉCHÈTERIE

Points de collecte sur www.quefairedemesdechets.fr
Privilégiez la réparation ou le don de votre appareil !



2PERS



90 MIN

Tool Required Not Provided

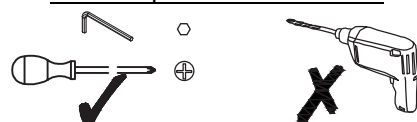



[DE]

Warnung: Lesen Sie die Anleitung vor dem Zusammenbau bitte vollständig durch. Überprüfen Sie, ob Sie alle auf den Seiten aufgeführten Komponenten und Werkzeuge haben.

Warnung: Legen Sie alle Teile auf eine ebene Fläche. Legen Sie eine weiche Decke oder Ähnliches darunter, um sie vor Kratzern oder Flecken zu schützen. Vermeiden Sie es, Komponenten über den Boden zu ziehen oder zu schieben.

Warnung: Überprüfen Sie regelmäßig alle Beschläge und Befestigungen, um sicherzustellen, dass sie sicher sind und um Unfälle zu vermeiden. Wenn Teile fehlen, kaputt, beschädigt oder abgenutzt sind, verwenden Sie das Produkt nicht weiter, bis es mit vom Hersteller autorisierten Teilen repariert wurde.

Warnung: Lassen Sie Kinder nicht auf die Möbel klettern, da dies zum Umkippen und zu schweren Verletzungen führen kann. Bauen Sie die Möbel außerhalb der Reichweite von Kindern zusammen.

Warnung: Stellen Sie die Möbel nicht in die Nähe von Feuerquellen oder heißen Gegenständen, um Brandgefahr zu vermeiden.

Warnung: Reinigen Sie die Möbel mit einem feuchten Tuch oder Alkohol. Verwenden Sie keine Reinigungsmittel mit ätzenden Chemikalien.

Warnung: Dieses Produkt ist mit einer Kippschutzvorrichtung ausgestattet. Bitte installieren Sie diese Vorrichtung unbedingt, um unnötige Verletzungen durch Umkippen zu vermeiden.

[EN]

Warning: Please read instructions fully before starting assembly. Check you have all the components and tools listed on pages.

Warning: Please place all parts on a flat surface. Place a soft blanket or similar underneath to protect against scratches or stains. Avoid dragging or sliding components across the floor.

Warning: Regularly check all fittings and fastenings to ensure they are secure and to prevent accidents. If any parts are missing, broken, damaged, or worn, discontinue use of the product until repairs have been made using factory authorized parts.

Warning: Do not allow children to climb on the furniture as this may result in tipping and serious personal injury. Assemble the furniture away from the reach of children.

Warning: Do not place furniture close to fire sources or high-temperature objects to avoid the risk of fire

Warning: Clean furniture with a damp cloth or alcohol, avoid using cleaning agents containing corrosive chemicals.

Warning: This product is equipped with an anti-tilt device. Please be sure to install this device to prevent unnecessary injuries caused by tipping.

[FR]

Avertissement : Veuillez lire entièrement les instructions avant de commencer l'assemblage. Vérifiez que vous disposez de tous les composants et outils répertoriés sur les pages.

Avertissement : Veuillez placer toutes les pièces sur une surface plane. Placez une couverture douce ou similaire en dessous pour les protéger des rayures ou des taches. Évitez de faire glisser les composants sur le sol.

Avertissement : Vérifiez régulièrement tous les raccords et fixations pour vous assurer qu'ils sont bien fixés et pour éviter les accidents. Si des pièces manquent, sont cassées, endommagées ou usées, cessez d'utiliser le produit jusqu'à ce que des réparations aient été effectuées à l'aide de pièces autorisées par l'usine.

Avertissement : Ne laissez pas les enfants grimper sur les meubles car cela pourrait entraîner un basculement et des blessures graves. Assemblez les meubles hors de portée des enfants.

Avertissement : Ne placez pas les meubles à proximité de sources de feu ou d'objets à haute température pour éviter tout risque d'incendie.

Avertissement : Nettoyez les meubles avec un chiffon humide ou de l'alcool, évitez d'utiliser des produits de nettoyage contenant des produits chimiques corrosifs.

Avertissement : Ce produit est équipé d'un dispositif anti-basculement. Assurez-vous d'installer ce dispositif pour éviter les blessures inutiles causées par un basculement.

[IT]

Attenzione: leggere attentamente le istruzioni prima di iniziare il montaggio. Verificare di avere tutti i componenti e gli strumenti elencati nelle pagine.

Attenzione: posizionare tutte le parti su una superficie piana. Posizionare una coperta morbida o simile sotto per proteggere da graffi o macchie. Evitare di trascinare o far scivolare i componenti sul pavimento.

Attenzione: controllare regolarmente tutti i raccordi e i dispositivi di fissaggio per assicurarsi che siano sicuri e per prevenire incidenti. Se alcune parti sono mancanti, rotte, danneggiate o usurate, interrompere l'uso del prodotto fino a quando non siano state eseguite le riparazioni utilizzando parti autorizzate dalla fabbrica.

Attenzione: non consentire ai bambini di arrampicarsi sui mobili poiché ciò potrebbe causare ribaltamenti e gravi lesioni personali. Montare i mobili lontano dalla portata dei bambini.

Attenzione: non posizionare i mobili vicino a fonti di fuoco o oggetti ad alta temperatura per evitare il rischio di incendio

Attenzione: pulire i mobili con un panno umido o alcol, evitare di utilizzare detergenti contenenti sostanze chimiche corrosive.

Attenzione: questo prodotto è dotato di un dispositivo antiribaltamento. Assicurarsi di installare questo dispositivo per prevenire lesioni inutili causate dal ribaltamento.

[ES]

Advertencia: Lea las instrucciones completamente antes de comenzar el montaje. Compruebe que tiene todos los componentes y herramientas que se enumeran en las páginas.

Advertencia: Coloque todas las piezas sobre una superficie plana. Coloque una manta suave o algo similar debajo para protegerlas de rayones o manchas. Evite arrastrar o deslizar los componentes por el piso.

Advertencia: Verifique regularmente todos los accesorios y fijaciones para asegurarse de que estén seguros y evitar accidentes. Si falta alguna pieza, está rota, dañada o desgastada, deje de usar el producto hasta que se hayan realizado las reparaciones con piezas autorizadas de fábrica.

Advertencia: No permita que los niños se suban a los muebles, ya que esto puede provocar que se vuelquen y lesiones personales graves. Monte los muebles fuera del alcance de los niños.

Advertencia: No coloque los muebles cerca de fuentes de fuego u objetos de alta temperatura para evitar el riesgo de incendio.

Advertencia: Limpie los muebles con un paño húmedo o alcohol, evite usar agentes de limpieza que contengan químicos corrosivos.









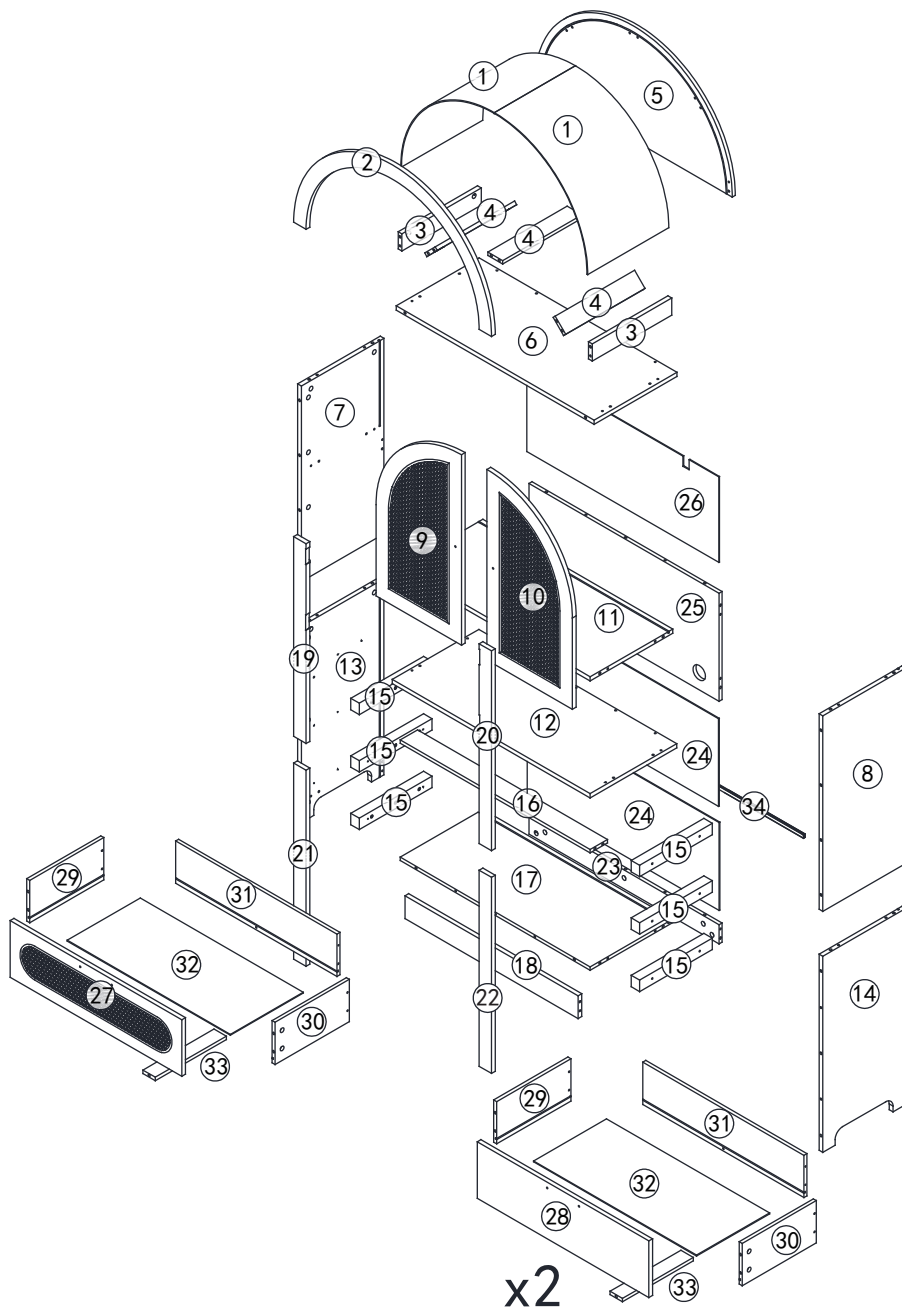

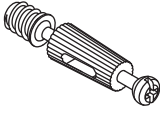
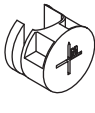
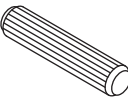
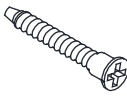

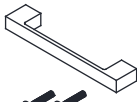

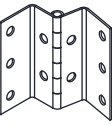
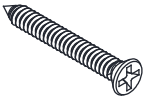



Advertencia: Este producto está equipado con un dispositivo antivuelco. Asegúrese de instalar este dispositivo para evitar lesiones innecesarias causadas por vuelcos.



DE
Warnung: Die maximale Belastbarkeit dieses Möbels beträgt: 45 kg, bitte nicht überlasten!
EN
Warning: The maximum load-bearing capacity of this furniture is: 45 kg, please do not overload!
FR
Avertissement : La capacité de charge maximale de ce meuble est de :45 kg, merci de ne pas surcharger !
IT
Attenzione: la capacità di carico massima di questo mobile è: 45 kg, non sovraccaricare!
ES
Advertencia: La capacidad máxima de carga de este mueble es: 45 kg, ¡no lo sobrecargue!

Importeur	Decobus Handel GmbH
Adresse	Innungsstraße 9, 21244 Buchholz, Deutschland
URL	https://www.decobusgroup.de
Hersteller	JIANGSU CHAONENG NEW MATERIALS TECHNOLOGY Co.,LTD.
Adresse	Guannan County Economic Development Zone, Lianyungang City (south of Provincial Highway 235)
Email/URL	lixinrui@jschaonengcl.com.cn
Hergestellt in	CHINA
	Decobus Handel GmbH Innungsstraße 9, 21244 Buchholz, Deutschland https://www.decobusgroup.de

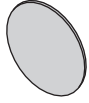
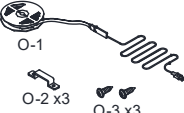

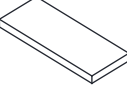
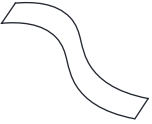
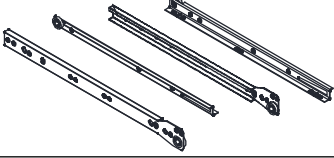
						
$\Phi 6 \times 35$	$\Phi 15 \times 9.5$	$\Phi 6 \times 30$	$\Phi 5 \times 40$	$\Phi 3.5 \times 12 \text{mm}$		
Ax82	Bx82	Cx52	Dx29	Ex64	Fx3	Gx2
		 J1  J2 $\phi 3 \times 14 \text{mm}$	 K-1  K-2 $\phi 3.5 \times 12 \text{mm}$  K-3  K-4 $\phi 4 \times 40 \text{mm}$	 L-1  L-2  L-3  L-4		
Hx4	Ix18	Jx16	Kx2	Lx1	Mx2	Nx82
 O-1  O-2 x3  O-3 x3						
Ox1	Px4	Qx1	CL+CR+DL+DRx3			

USING CAM LOCK AND QUICKFIT

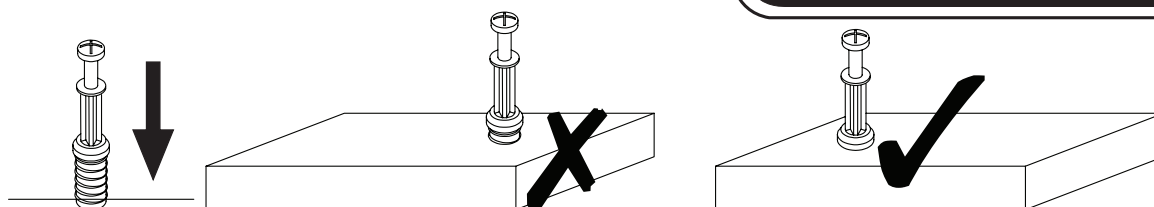

EN_QUICKFIT: Tighten quickfit until shoulder is flush with panel. Do not overtighten or undertighten.

FR_RACCORD RAPIDE: Faites serrer le raccord rapide jusqu'à ce que l'épaulement soit parfaitement encastré dans le panneau. Il ne faut ni trop serrer ni insuffisamment serrer.

ES_QUICKFIT: Apriete quickfit hasta que el hombro se descargue con el panel. NO lo sobreapriete ni lo apriete poco.

DE_QUICKFIT: Ziehen Sie den Quickfit fest, bis die Schulter mit der Platte bündig ist. Bitte nicht zu fest oder zu schwach anziehen.

IT_MONTAGGIO RAPIDO: Stringere il montaggio rapido fino a quando la spalla è a filo con il pannello, non stringere troppo o troppo poco.

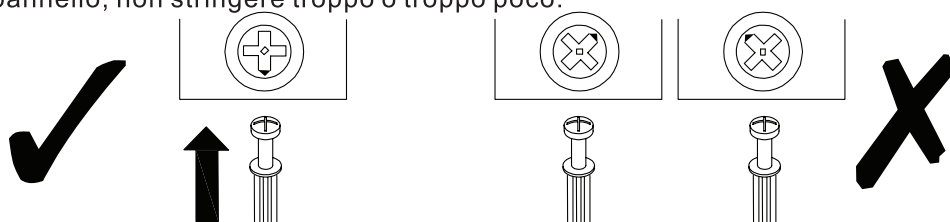

EN_CAM LOCK: When fitting cam lock, ensure starting position is correct before you insert connecting quickfit.

FR_SERRURE BATTEUSE: Avant d'insérer la serrure batteuse, veillez à la bonne orientation avant d'insérer le raccord rapide.

ES_CIERRE DE LA CÁMARA: Cuando instale el cierre de la cámara, asegúrese de que la posición de inicio es correcta antes de que inserte el quickfit conector.

DE_CAM-LOCK: Achten Sie bei der Montage des Cam-Locks auf die richtige Ausgangsposition, bevor Sie den Quickfit einsetzen.

IT_BLOCCAGGIO A CAMMA: Quando si monta il bloccaggio a camma, assicurarsi che la posizione iniziale sia corretta prima di inserire il montaggio rapido di collegamento.

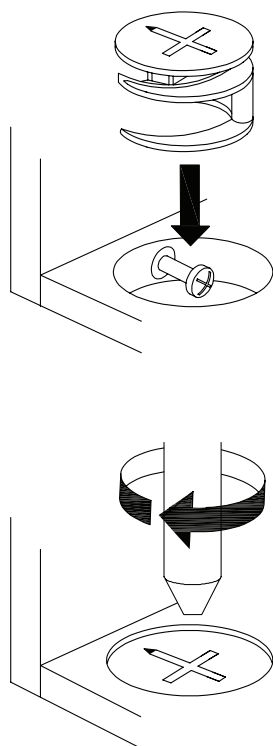

EN_Quickfit head should be in the centre of the cam lock when the two panels are joined.

Cam lock should be inserted before quickfit.

FR_Lorsque les deux panneaux sont assemblés, la tête du raccord rapide doit reposer au centre de la serrure batteuse. Il faut insérer la serrure batteuse avant le raccord rapide.

ES_El cabezal del quickfit debe estar en el centro del cierre de la cámara cuando se unan los dos paneles.

Se debe insertar el cierre de la cámara antes que el quickfit.

DE_Der Quickfit-Kopf sollte sich in der Mitte des Cam-Locks befinden, wenn die beiden Platten zusammengefügt sind.

Der Cam-Lock sollte vor dem Quickfit eingesetzt werden.

IT_La testa del montaggio rapido deve trovarsi al centro del bloccaggio a camma quando i due pannelli sono uniti.

Il Bloccaggio a Camma deve essere inserito prima del montaggio rapido.

EN_Turn cam lock clockwise to tighten.

FR_Faites tourner la serrure batteuse dans le sens des aiguilles d'une montre pour la resserrer.

ES_Gire el cierre de la cámara en sentido horario para apretarlo.

DE_Drehen Sie den Cam-Lock im Uhrzeigersinn, um ihn festzuziehen.

IT_Ruotare il bloccaggio a camma in senso orario per stringere.

EN It may be necessary to adjust the hinges so that the doors align. Use the instructions below as a guide.

FR Il est parfois nécessaire d'ajuster les charnières pour un meilleur alignement des portes. Servez-vous des instructions ci-dessous comme guide.

ES Puede que sea necesario ajustar los quicios de forma que se alineen las puertas. Use las instrucciones que aparecen debajo como guía.

DE Möglicherweise müssen Sie die Scharniere so einstellen, dass die Türen ausgerichtet sind. Verwenden Sie die nachstehenden Anweisungen als Leitfaden.

IT Potrebbe essere necessario regolare le cerniere in modo che le porte siano allineate. Per fare ciò attenersi alle istruzioni sottostanti.

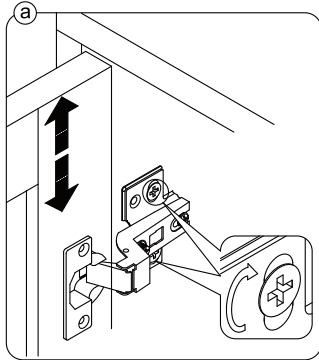

EN To adjust the door vertically loosen the screw as shown and move up and down as needed.

FR Si vous souhaitez régler la porte **verticalement**, desserrez la vis comme indiqué et déplacez la porte de haut en bas selon les besoins.

ES Para ajustar la puerta **verticalmente** afloje el tornillo tal y como se muestra y muévelo hacia arriba o hacia abajo según sea necesario.

DE Um die Tür **vertikal** auszurichten, lösen Sie die Schraube wie abgebildet und bewegen Sie sie nach Bedarf nach oben oder nach unten.

IT Per allineare la porta **verticalmente** allentare la vite come mostrato e spostarla in alto o in basso secondo necessità.

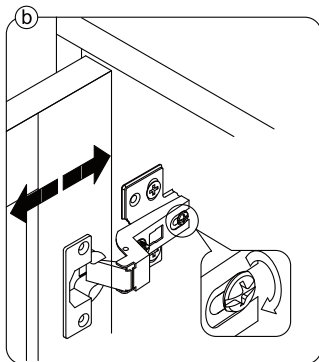

EN To adjust the gap from the door to the main frame turn the screw clockwise or anti-clockwise as needed.

FR Si vous souhaitez ajuster l'**écart** entre la porte et le cadre principal, tournez la vis dans le sens des aiguilles d'une montre ou dans le sens inverse, si nécessaire.

ES Para ajustar el **espacio** desde la puerta al marco principal, gire el tornillo en sentido horario o antihorario, según se necesite.

DE Um den **Abstand** von der Tür zum Hauptrahmen auszurichten, drehen Sie die Schraube je nach Bedarf im oder gegen den Uhrzeigersinn.

IT Per regolare lo **spazio** tra la porta e il telaio principale, avvitare o svitare la vite secondo necessità.

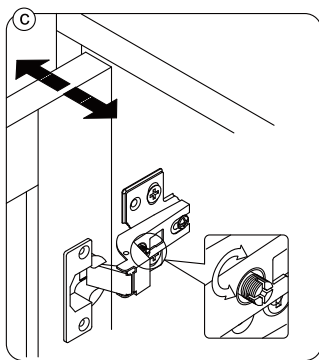

EN To adjust the door laterally adjust the screw as shown by turning clockwise or anti-clockwise.

FR Si vous souhaitez ajuster la porte **latéralement**, ajustez la vis comme indiqué en tournant dans le sens des aiguilles d'une montre ou dans le sens inverse des aiguilles d'une montre.

ES Para ajustar la puerta **lateralmente** ajuste el tornillo tal y como se muestra girándolo en sentido horario y antihorario.

DE Um die Tür **seitlich** auszurichten, stellen Sie bitte die Schraube wie abgebildet durch Drehen im oder gegen den Uhrzeigersinn ein.

IT Per allineare la porta **lateralmente** regolare la vite come mostrato, avvitandola o svitandola.

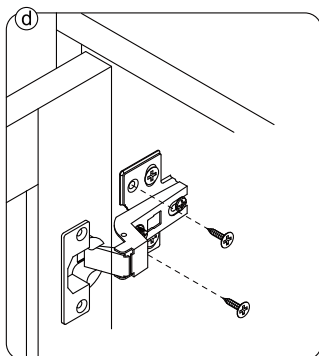

EN Please fix other screws

FR Merci de serrer les autres vis.

ES Fije los demás tornillos

DE Befestigen Sie bitte die anderen Schrauben

IT Fissare le altre viti

BOX 1-2	SKU: N657P420826	③③ 287*50*12mm=3pcs
①	588*329*2.5mm=2pcs	③④ 765mm=1pc
②	800*50*15mm=1pc	
③	321*60*15mm=2pcs	BOX 2-2
④	321*60*12mm=3pcs	SKU: N657P420827
⑤	798*399*12mm=1pc	⑦ 684*334*15mm=1pc
⑥	800*335*15mm=1pc	⑧ 684*334*15mm=1pc
⑨	665.5*345.5*15mm=1pc	⑪ 768*334*15mm=1pc
⑩	665.5*345.5*15mm=1pc	⑬ 686*334*15mm=1pc
⑫	800*335*15mm=1pc	⑭ 686*334*15mm=1pc
⑬	768*70*12mm=1pc	⑮ 294*40*34mm=6pcs
⑭	768*334*12mm=1pc	⑰ 694*198*15mm=1pc
⑮	700*80*15mm=1pc	⑱ 694*198*15mm=2pcs
⑯	699*50*15mm=1pc	⑳ 300*148*12mm=3pcs
⑰	699*50*15mm=1pc	㉑ 300*148*12mm=3pcs
⑱	686*50*15mm=1pc	㉒ 652*148*12mm=3pcs
⑲	686*50*15mm=1pc	 <p>Hardware Kit</p>
㉑	768*67*12mm=1pc	
㉒	776*307*3mm=2pcs	
㉓	768*378*12mm=1pc	
㉔	776*299*3mm=1pc	
㉕	659*295*3mm=3pcs	

1.

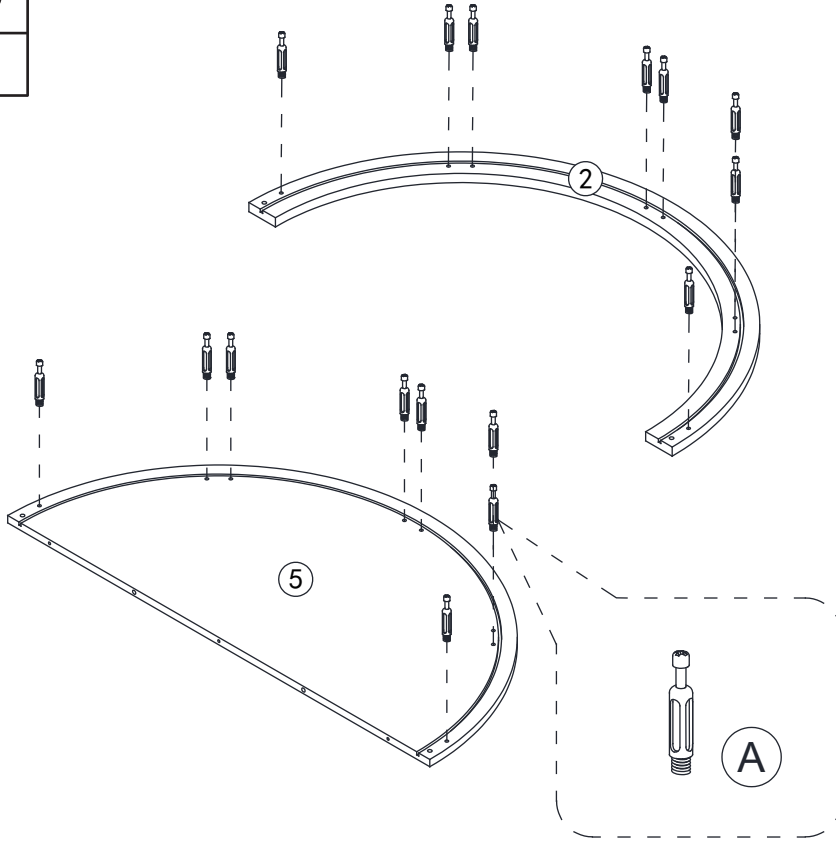
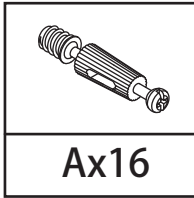

2.

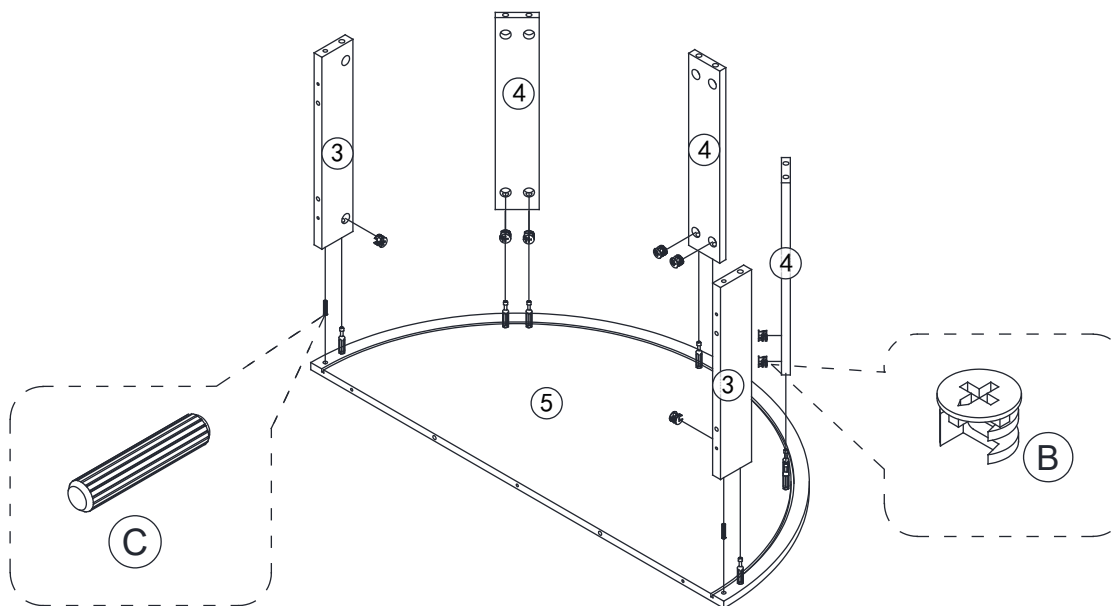
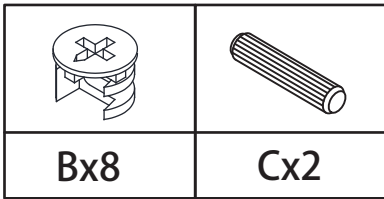

3.

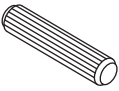
	
Bx8	Cx2

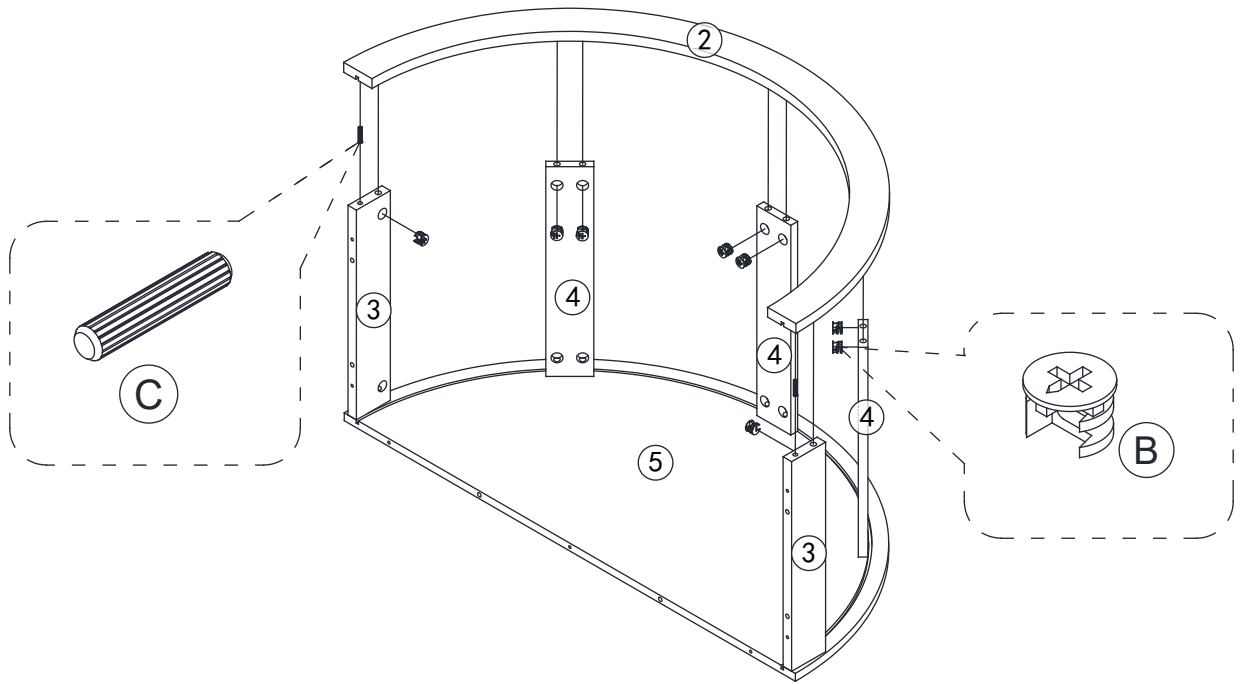



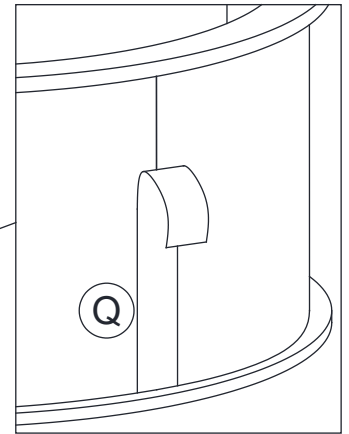
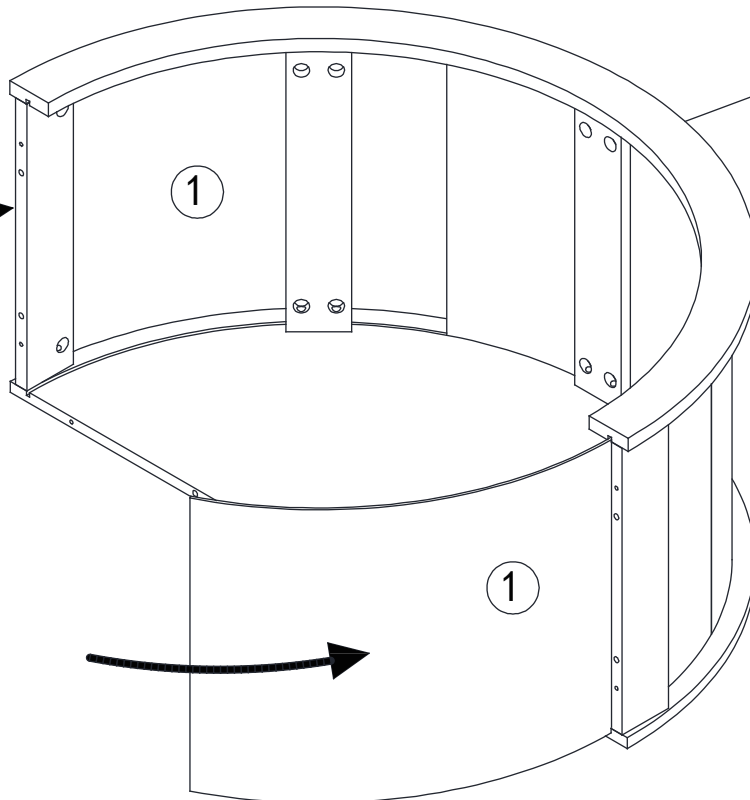

4.



Qx1

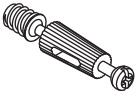

After installation, use tape (Q) to seal the seams

5.

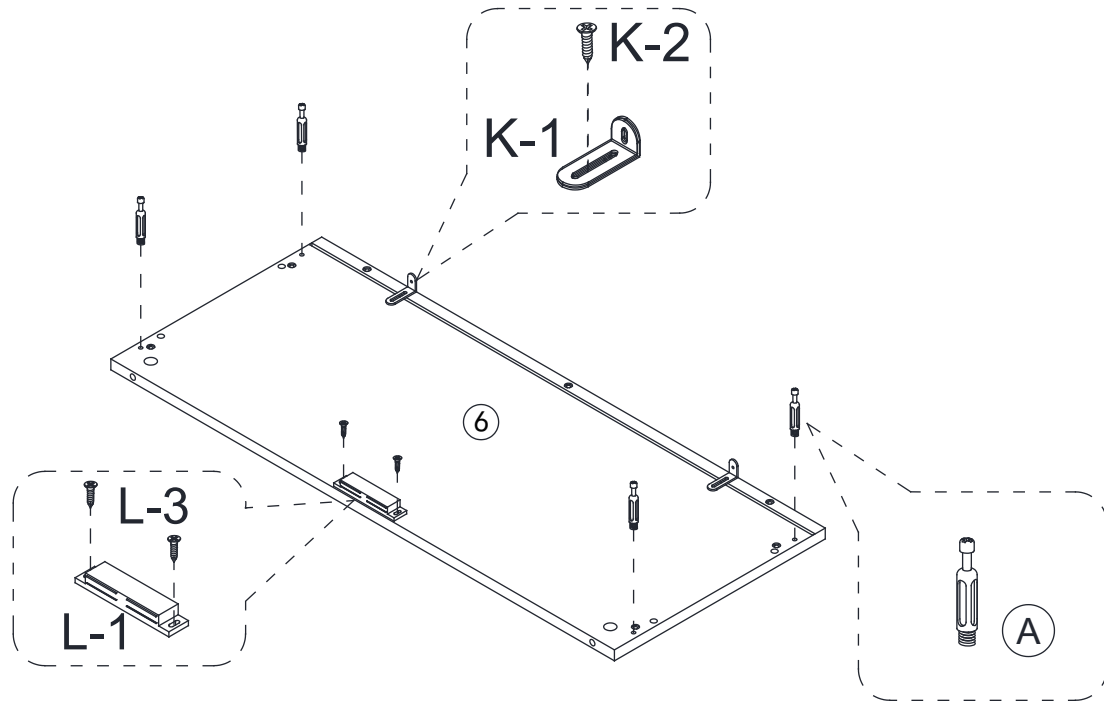
	 K-1	 K-2	 L-1	 L-3
Ax4	Kx2		Lx1	

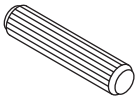
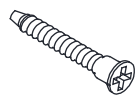

6.

	
Cx6	Dx7

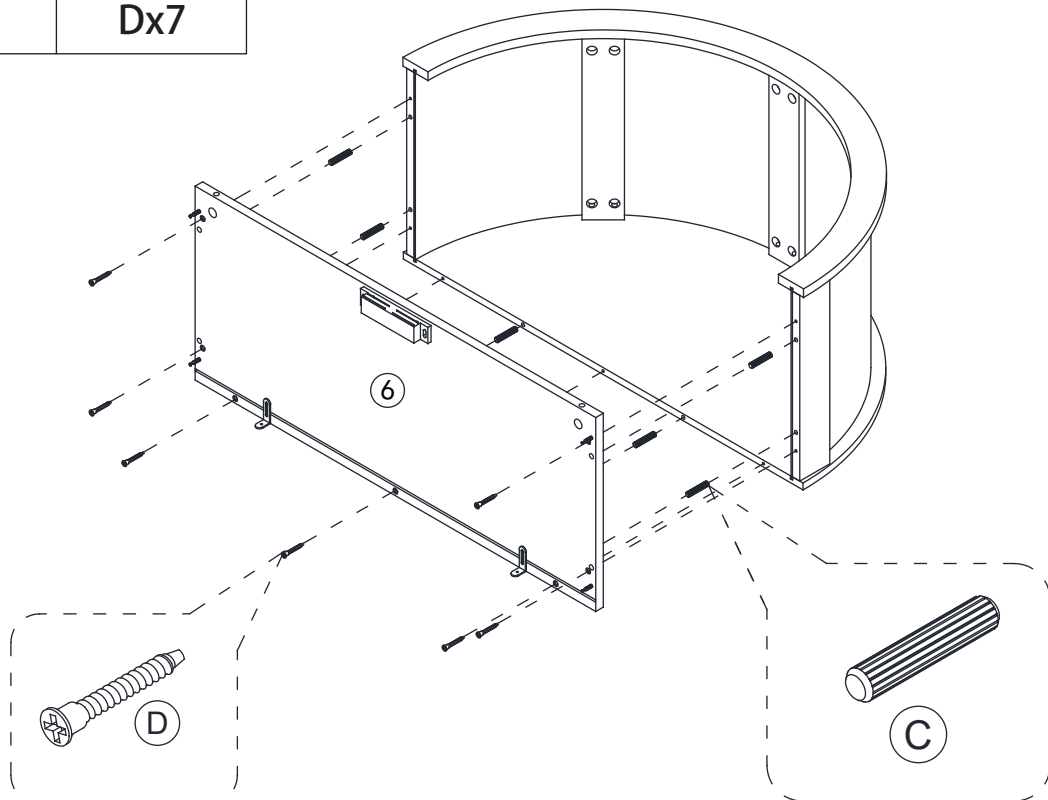

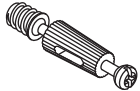
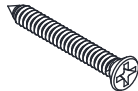

7.

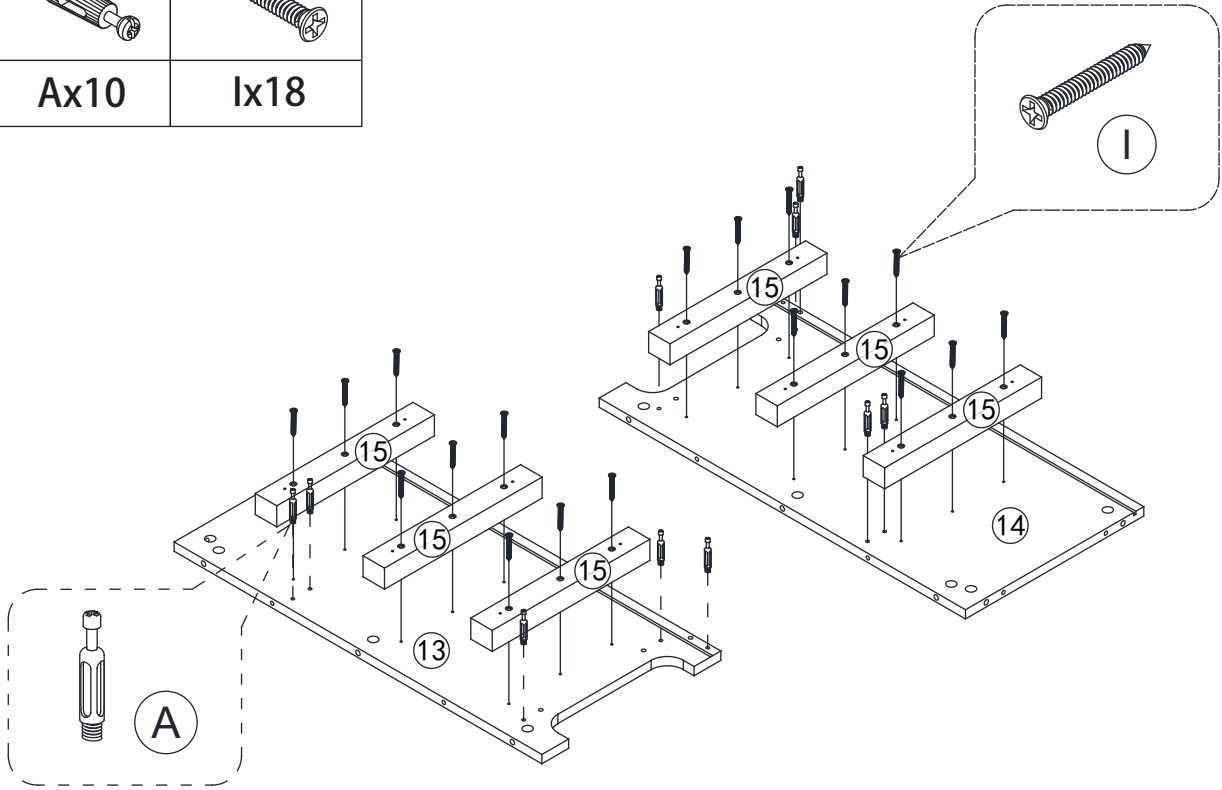
	
Ax10	Ix18

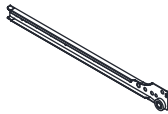

8.

		
Ex12	CLx3	CRx3

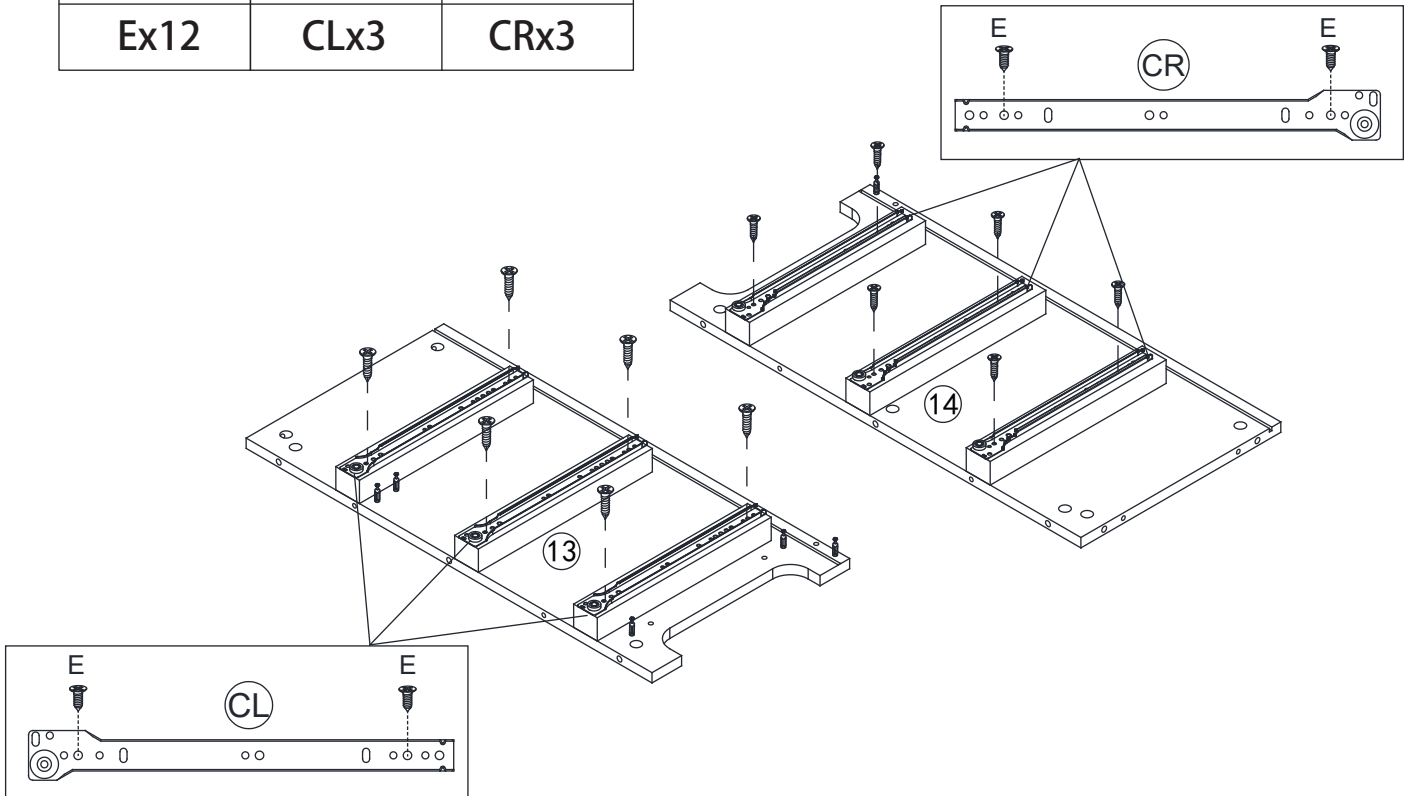

9.

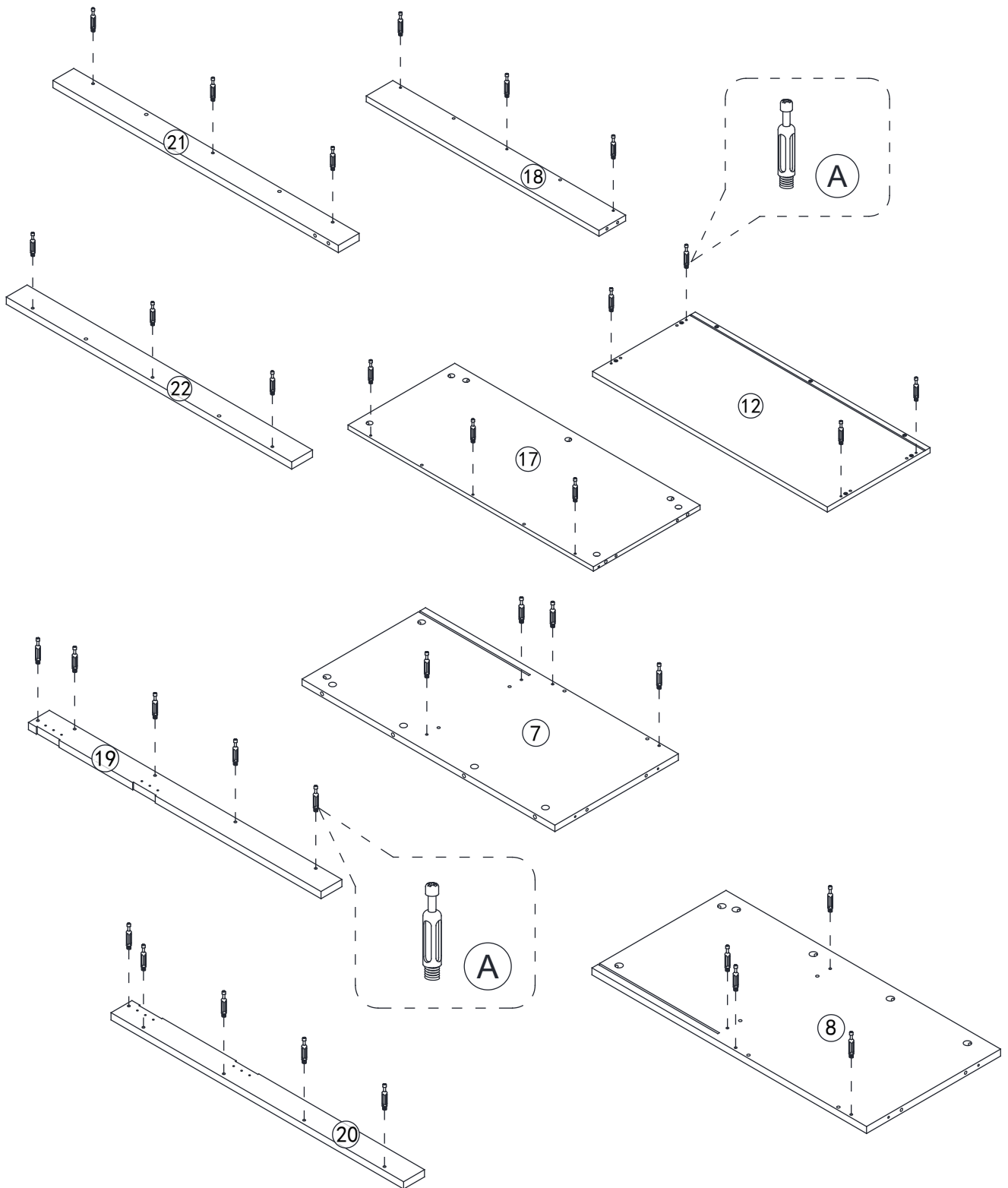
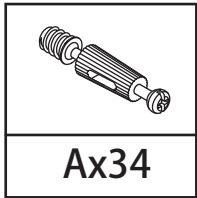

10.

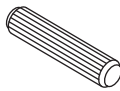
	
Bx3	Cx2

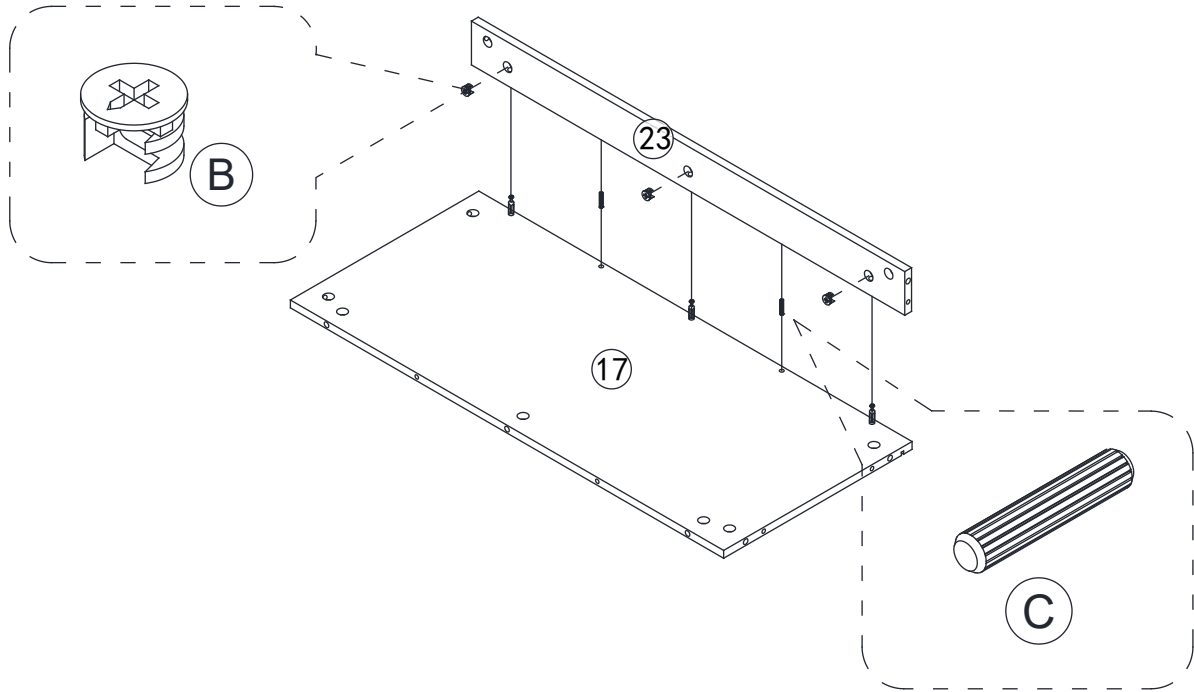

11.

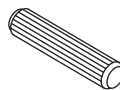
	
Bx10	Cx6

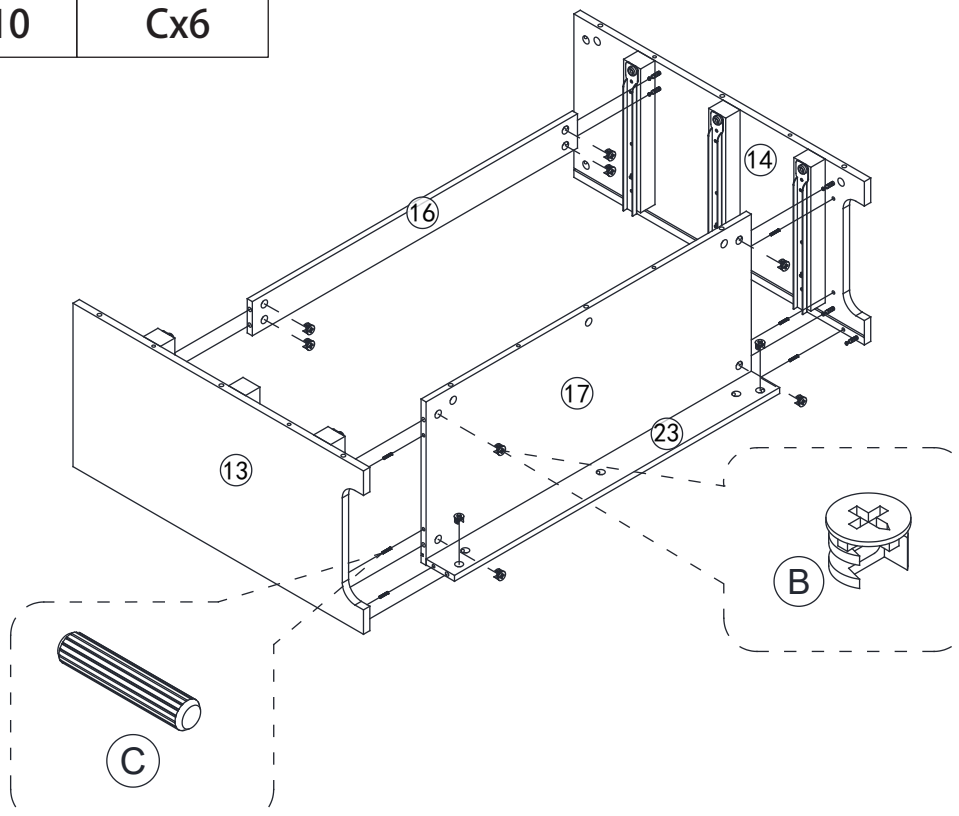

12.

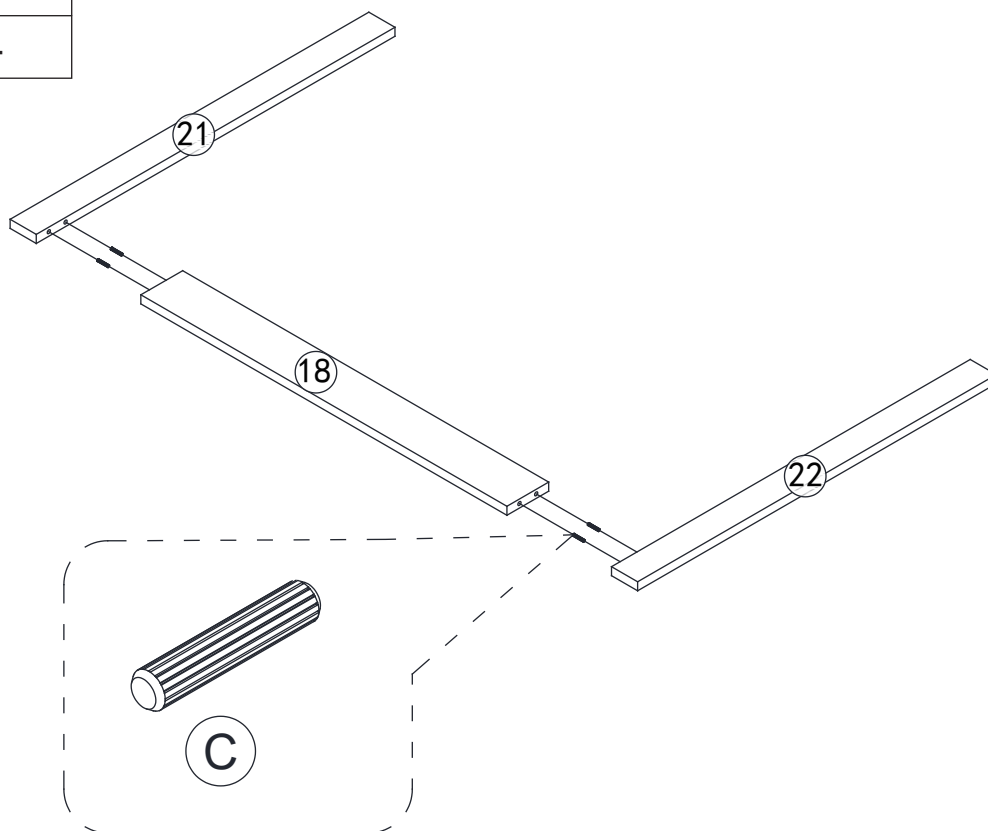
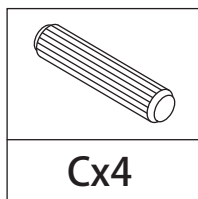

13.

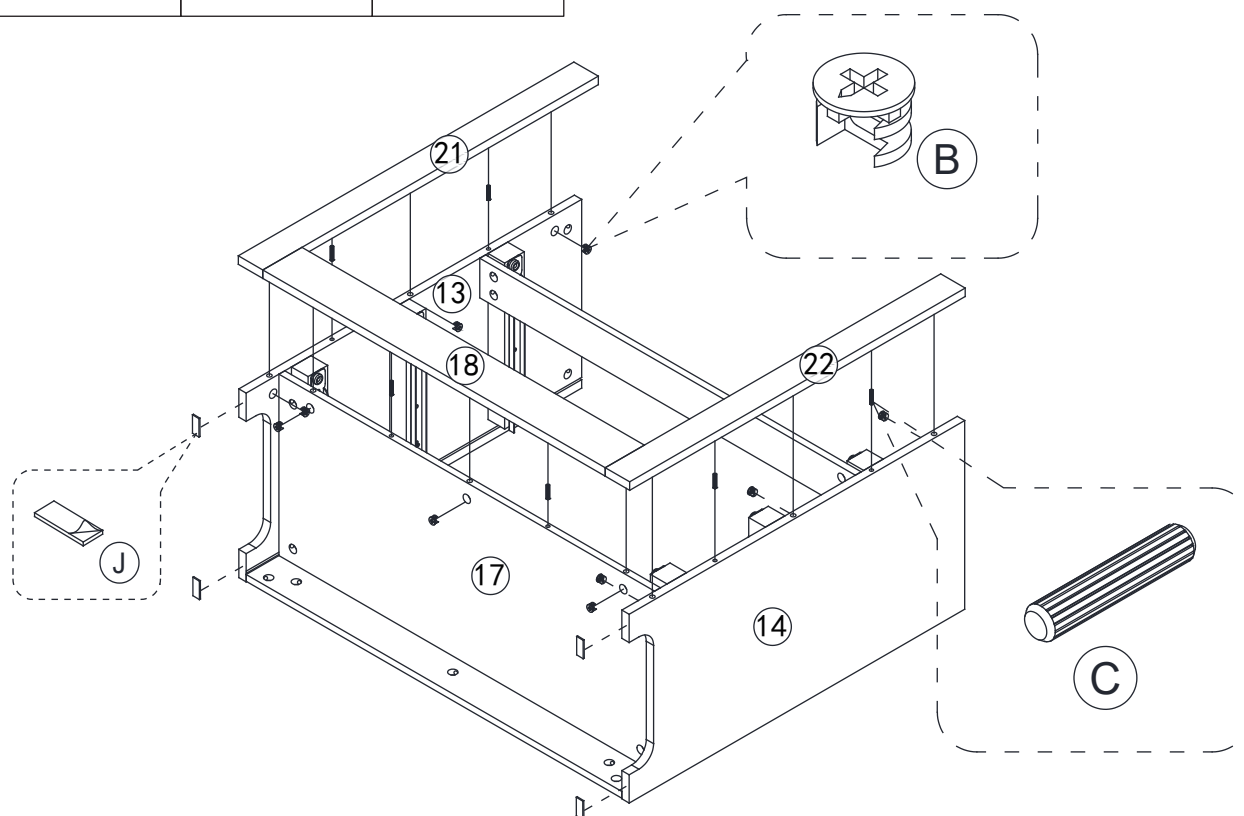
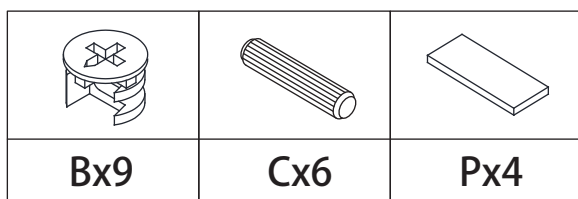

14.

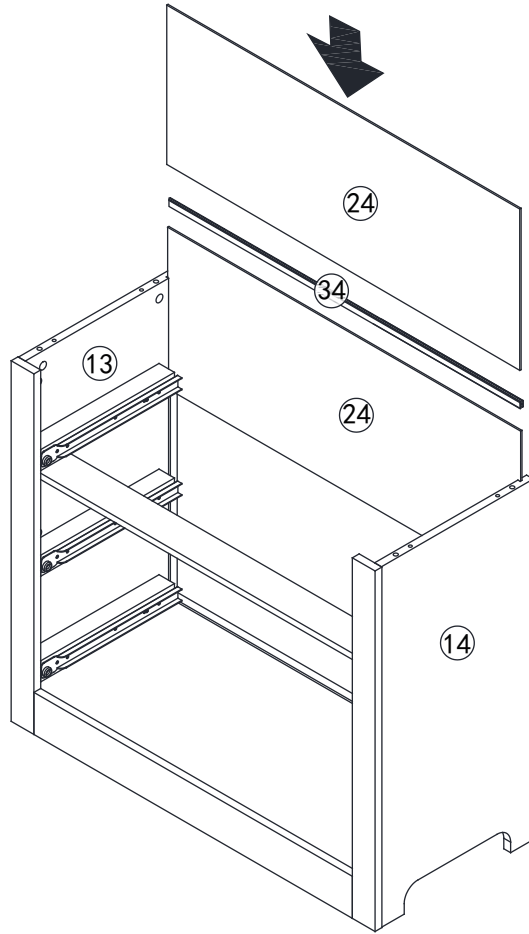

15.

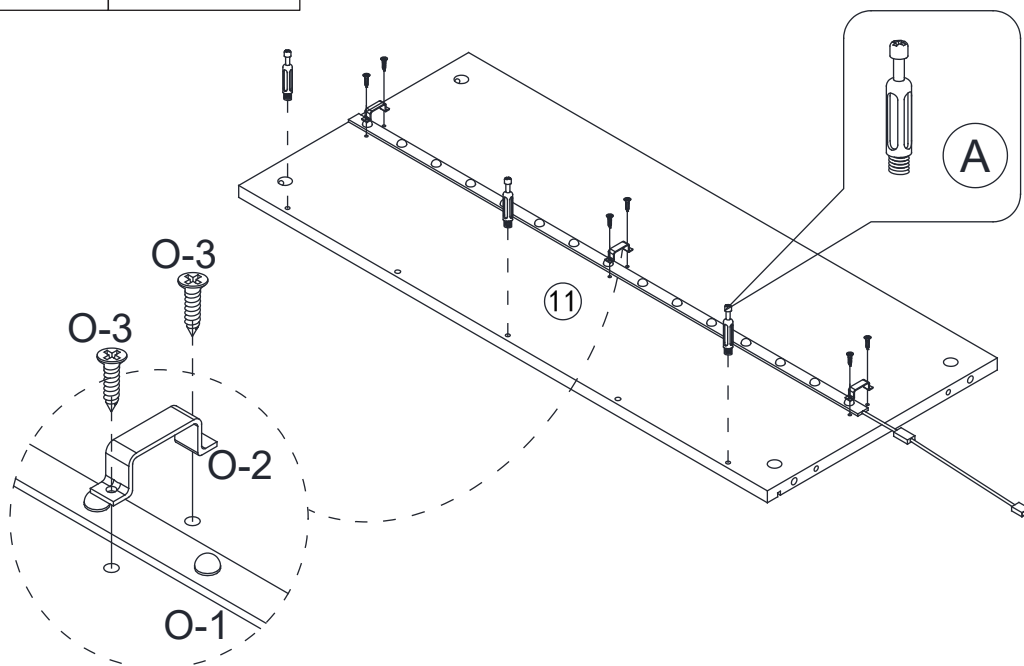
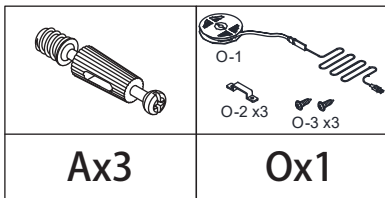

16.

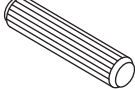
	
Bx3	Cx2

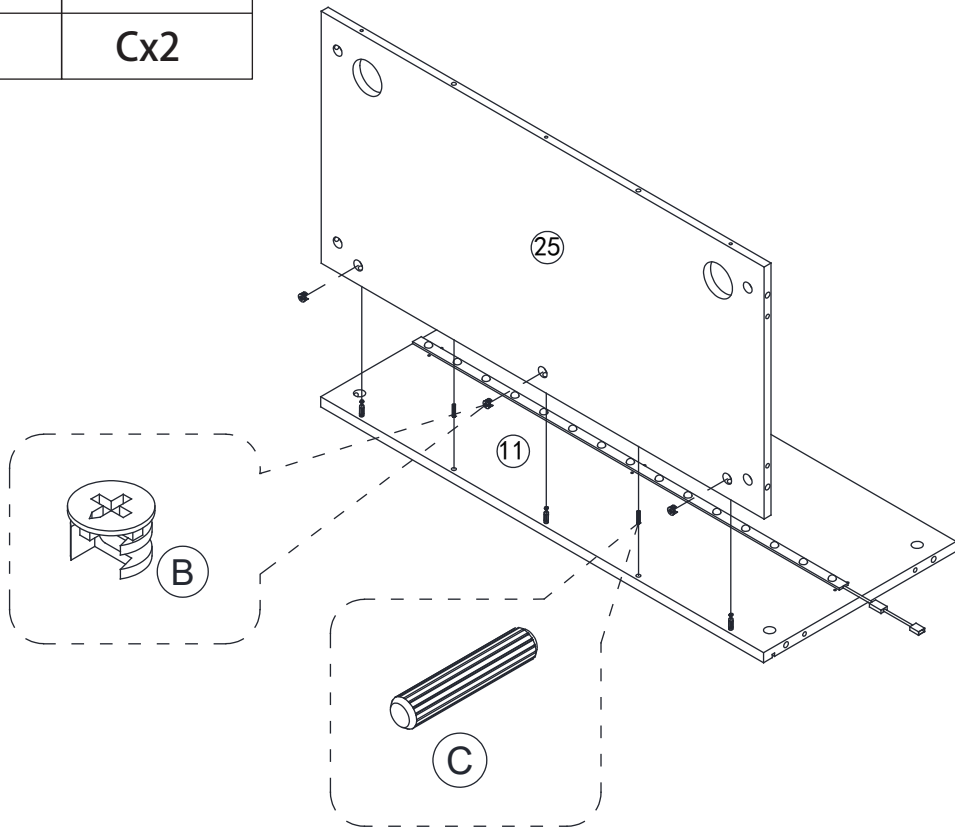

17.

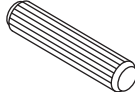
	
Bx8	Cx8

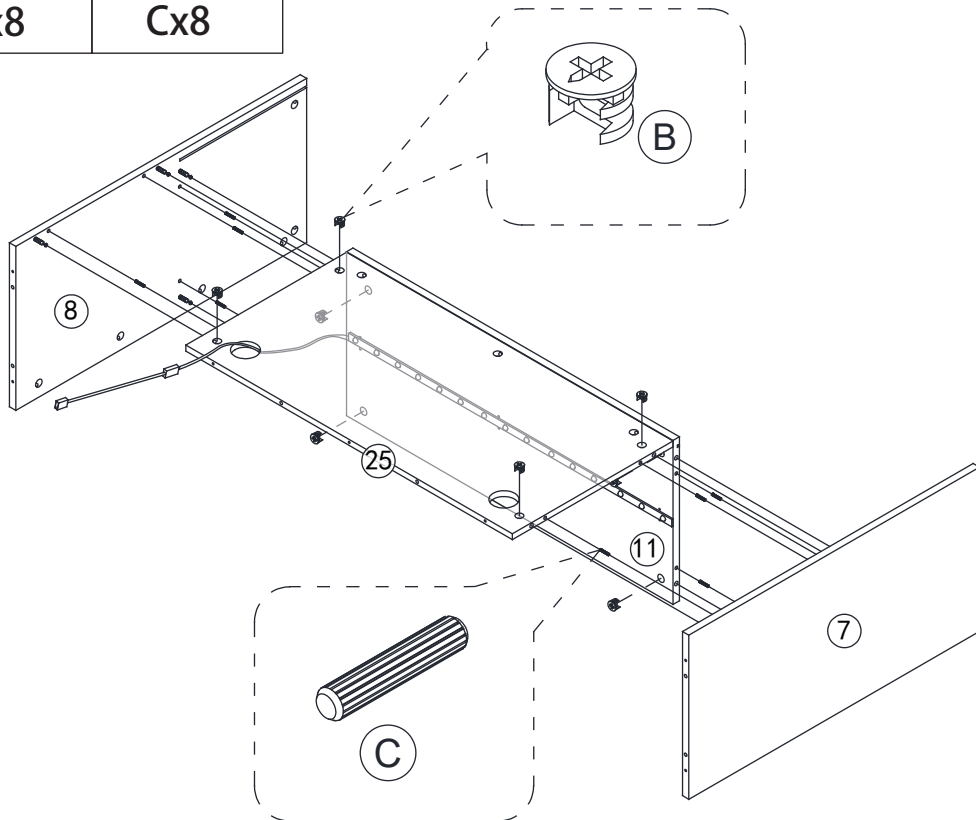

18.

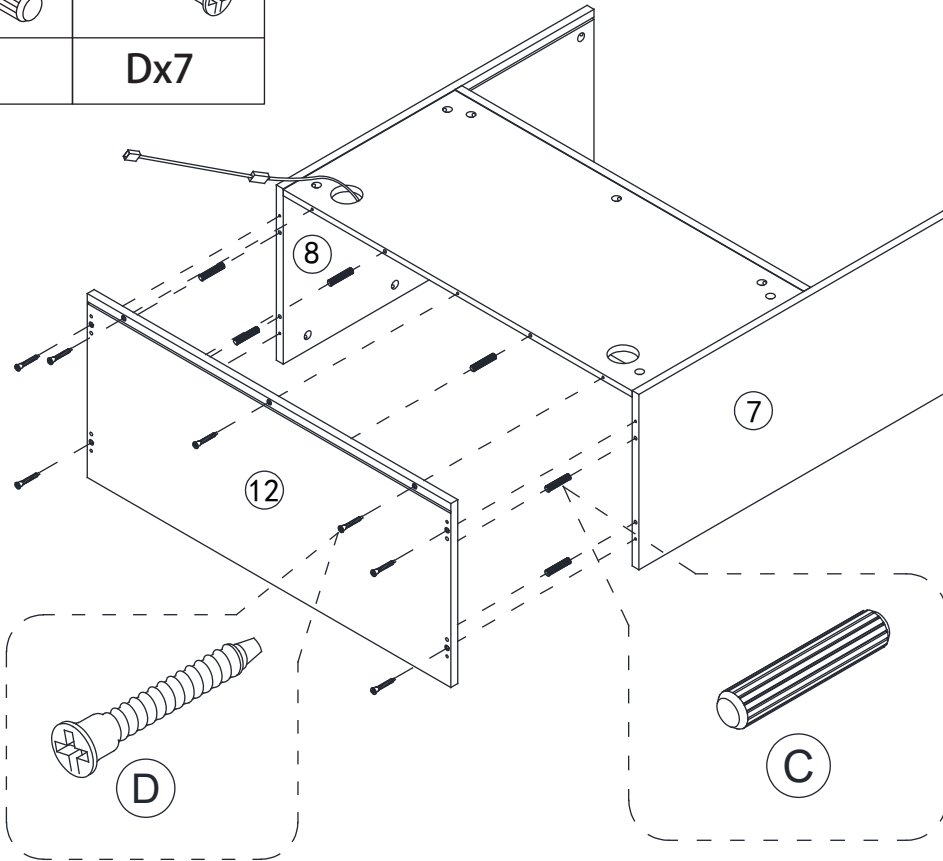
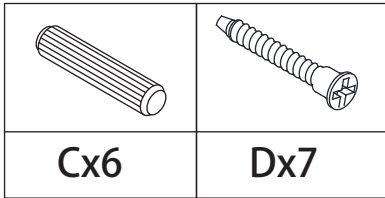

19.

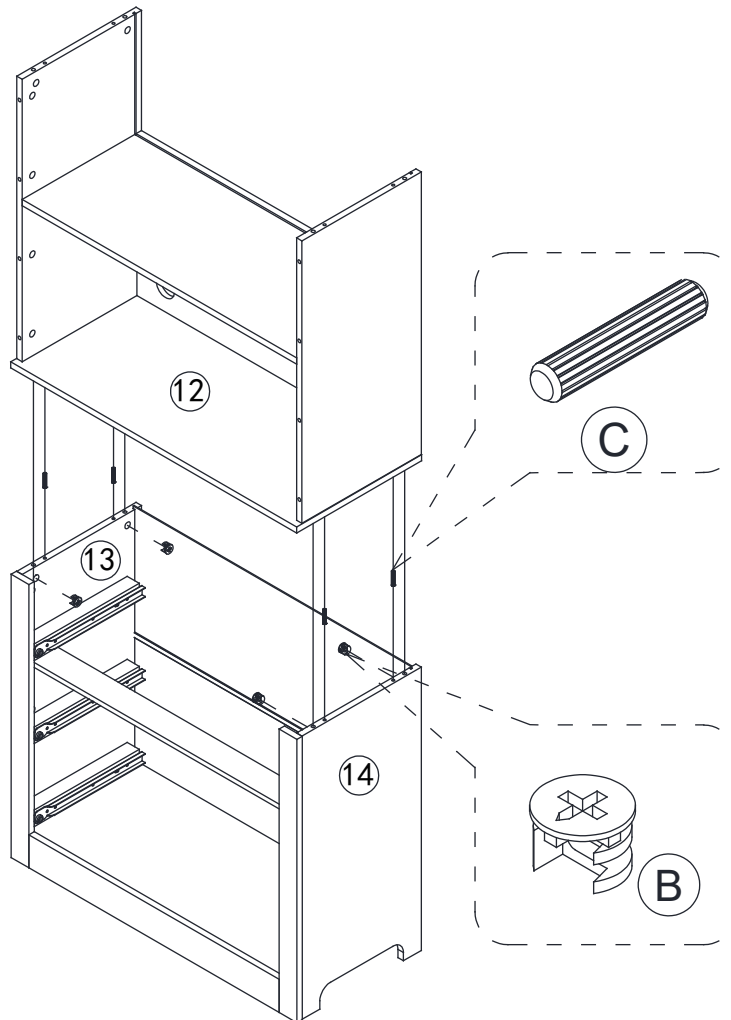
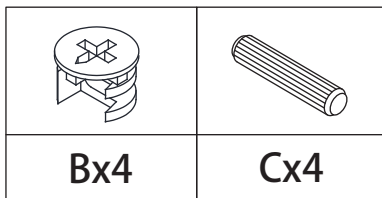

20.

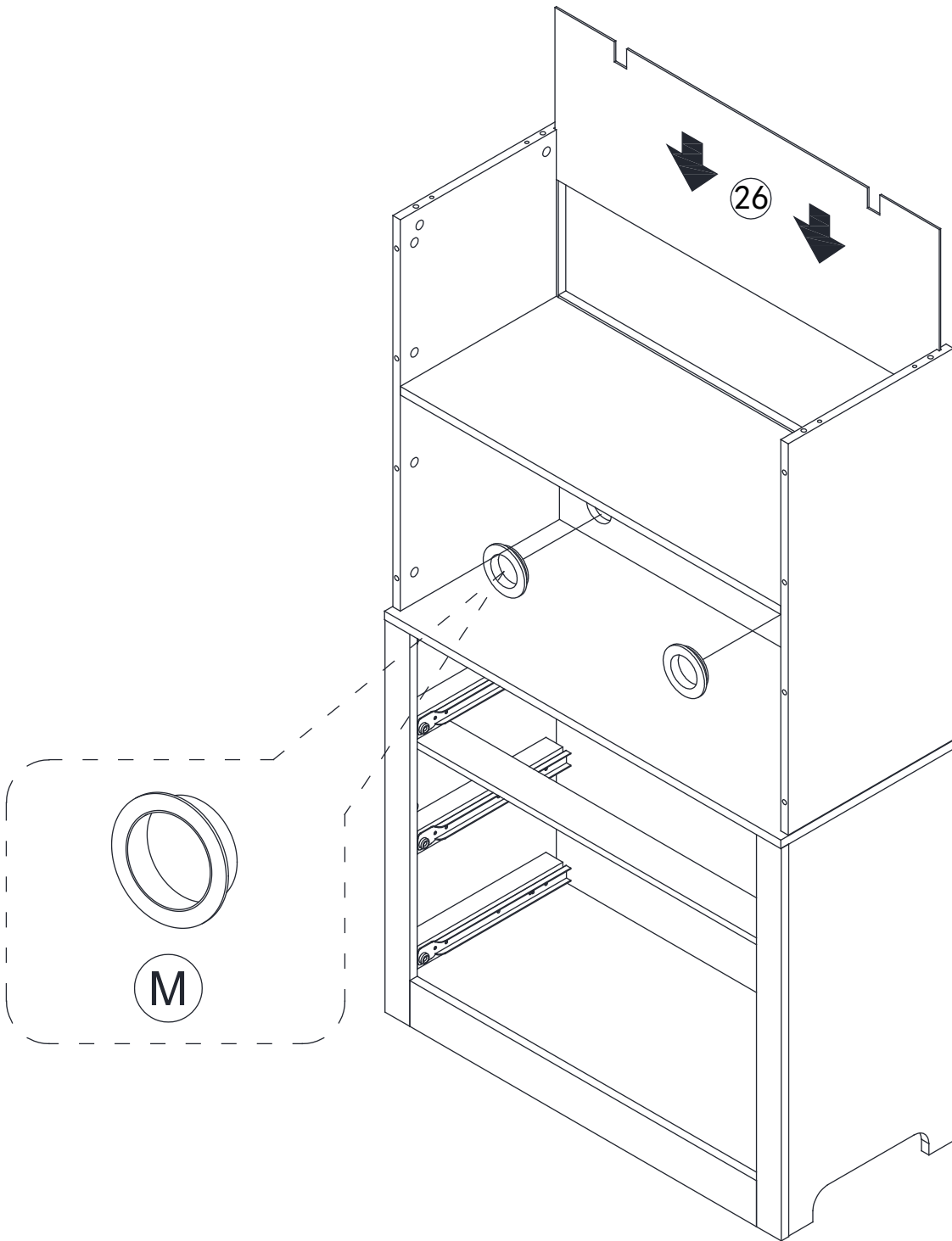
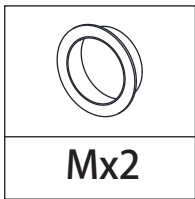

21.

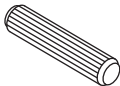

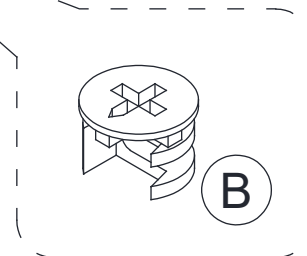
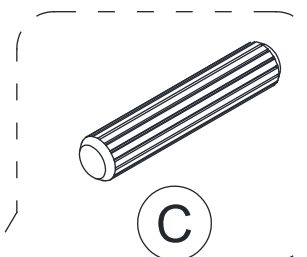
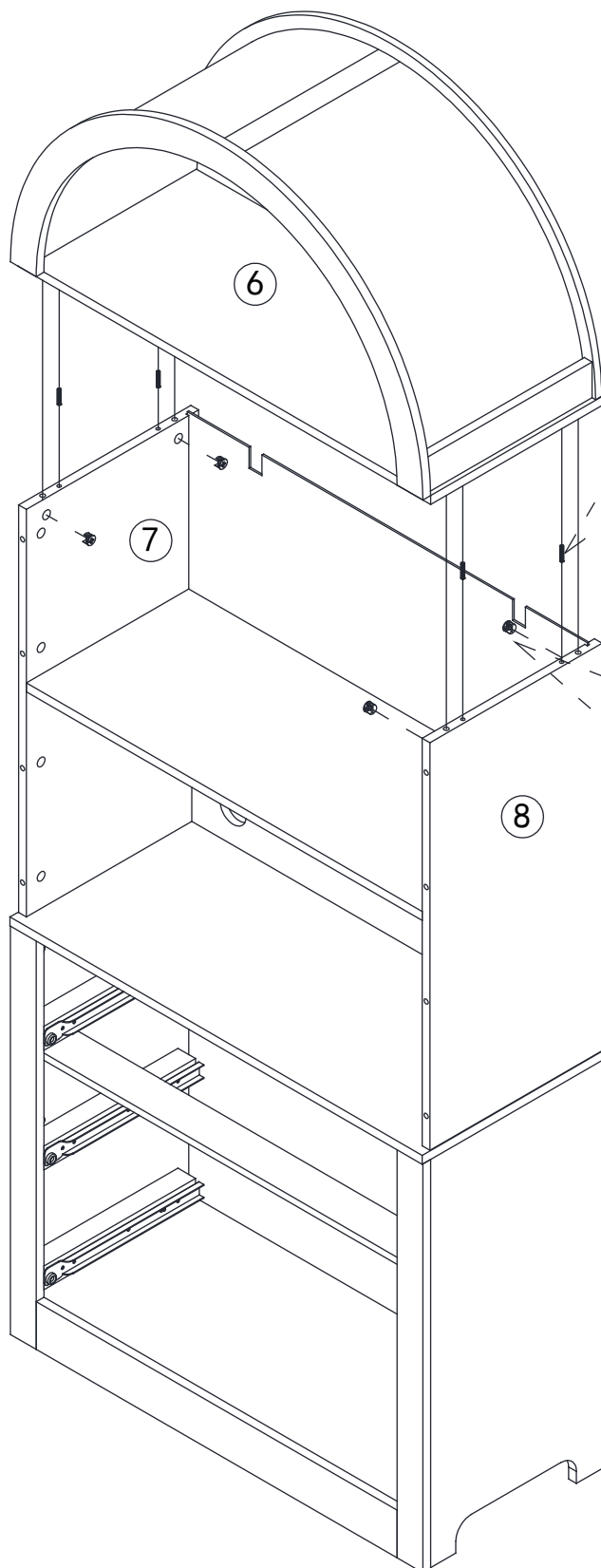
	
Bx4	Cx4

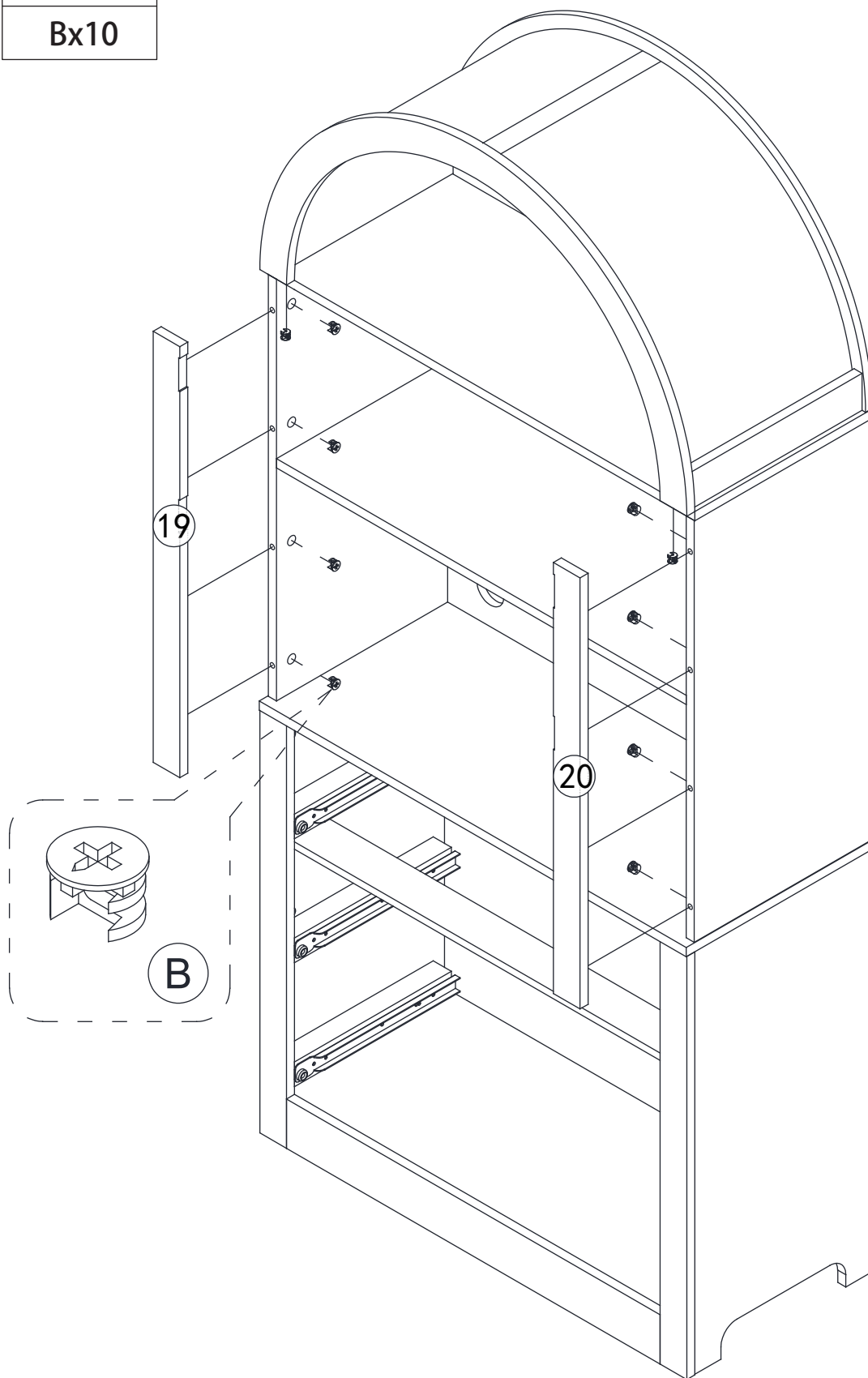
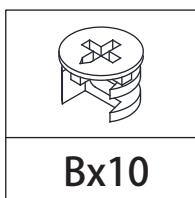

22.



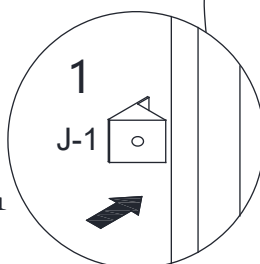
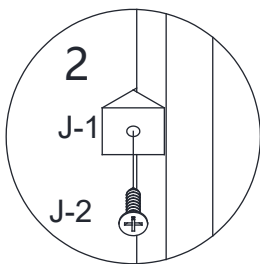
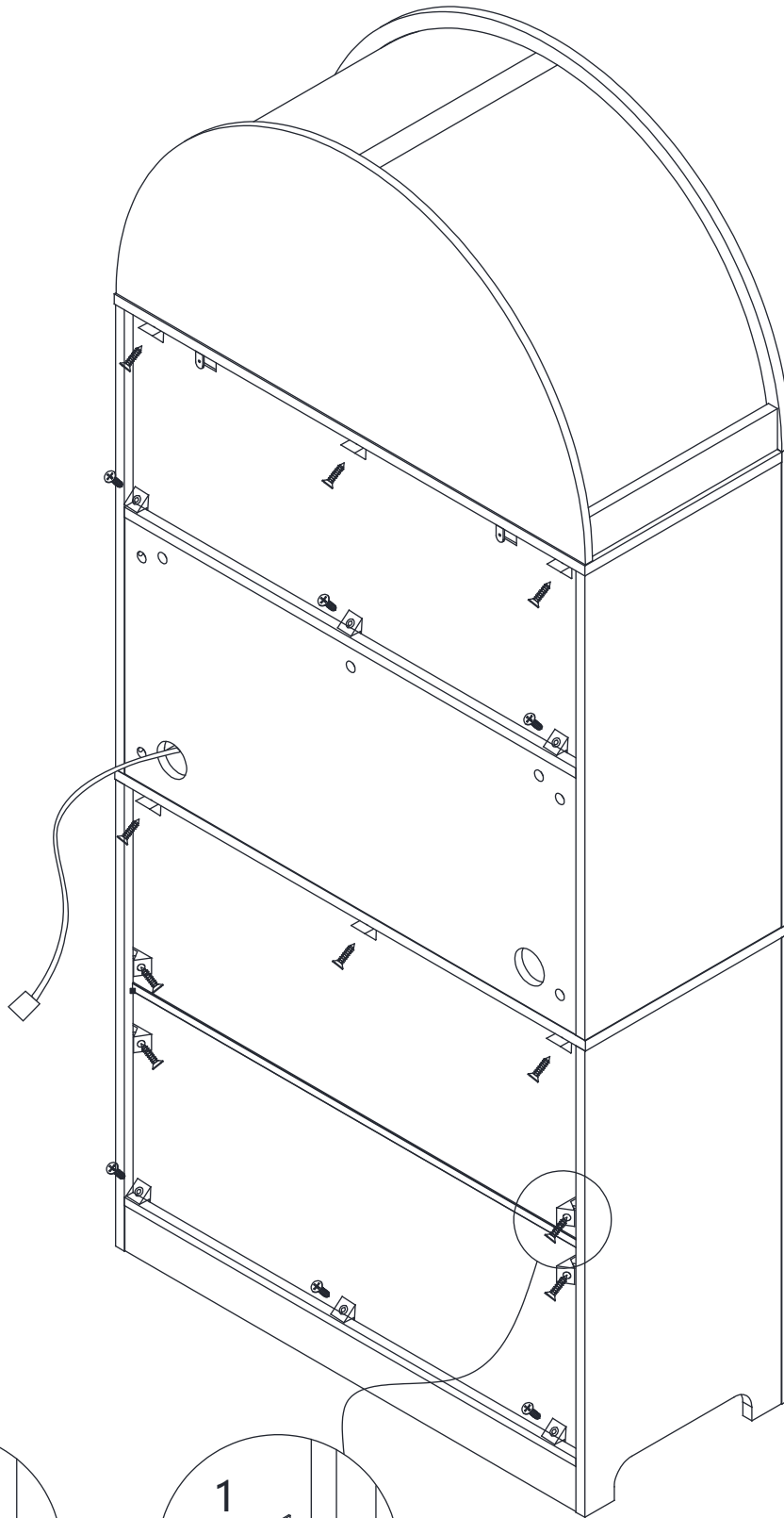

23.

 J1	 J2
Jx16	

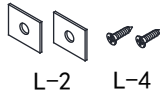

24.

			
Ex20	Gx2	Hx4	Lx2

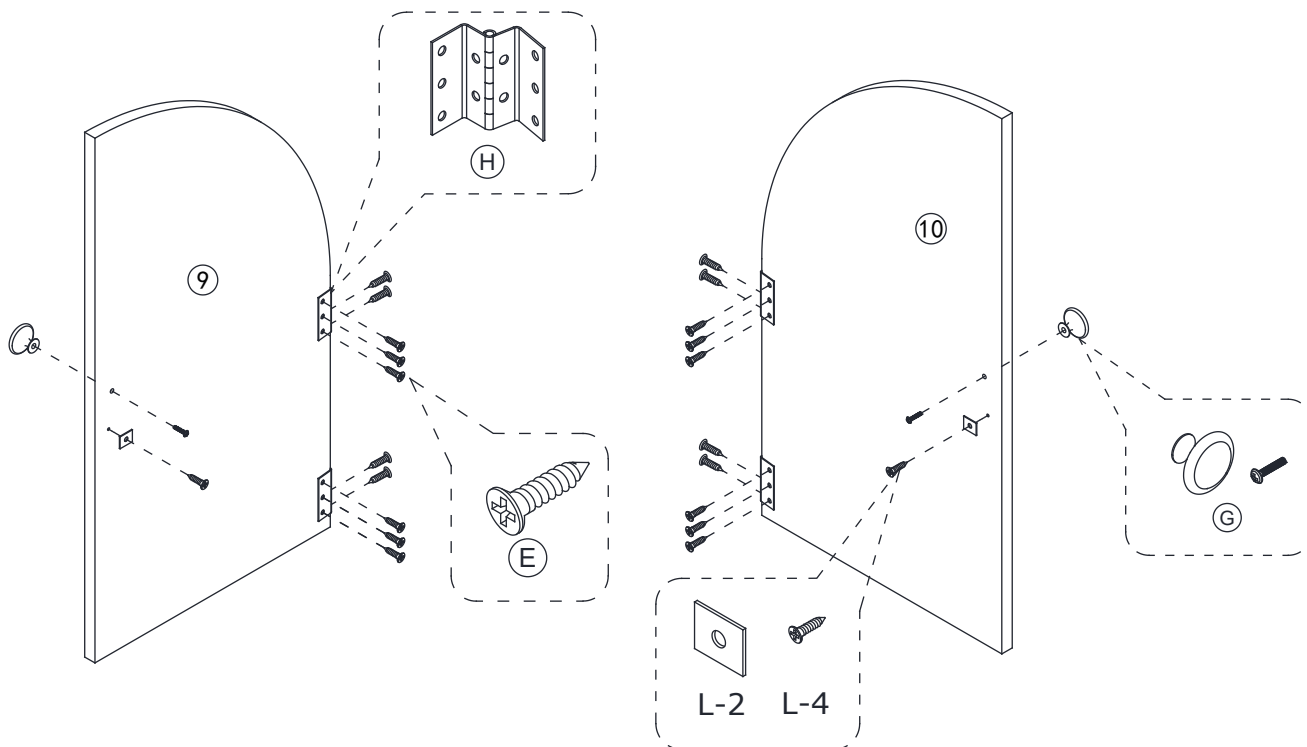

25.

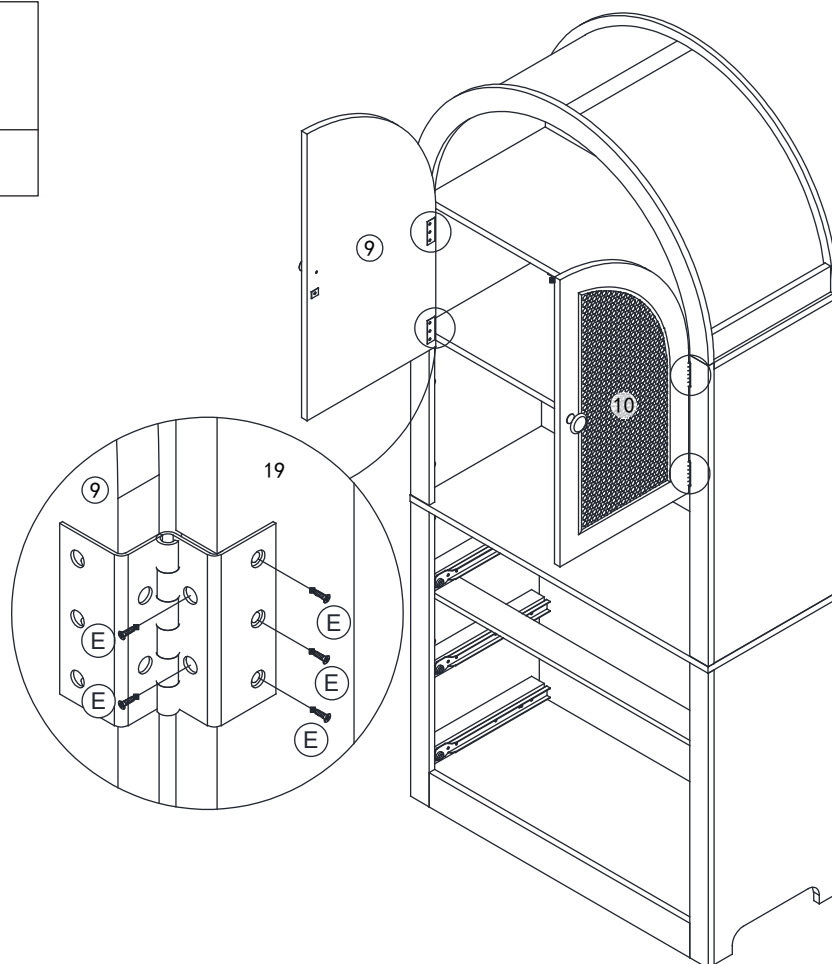

Ex20

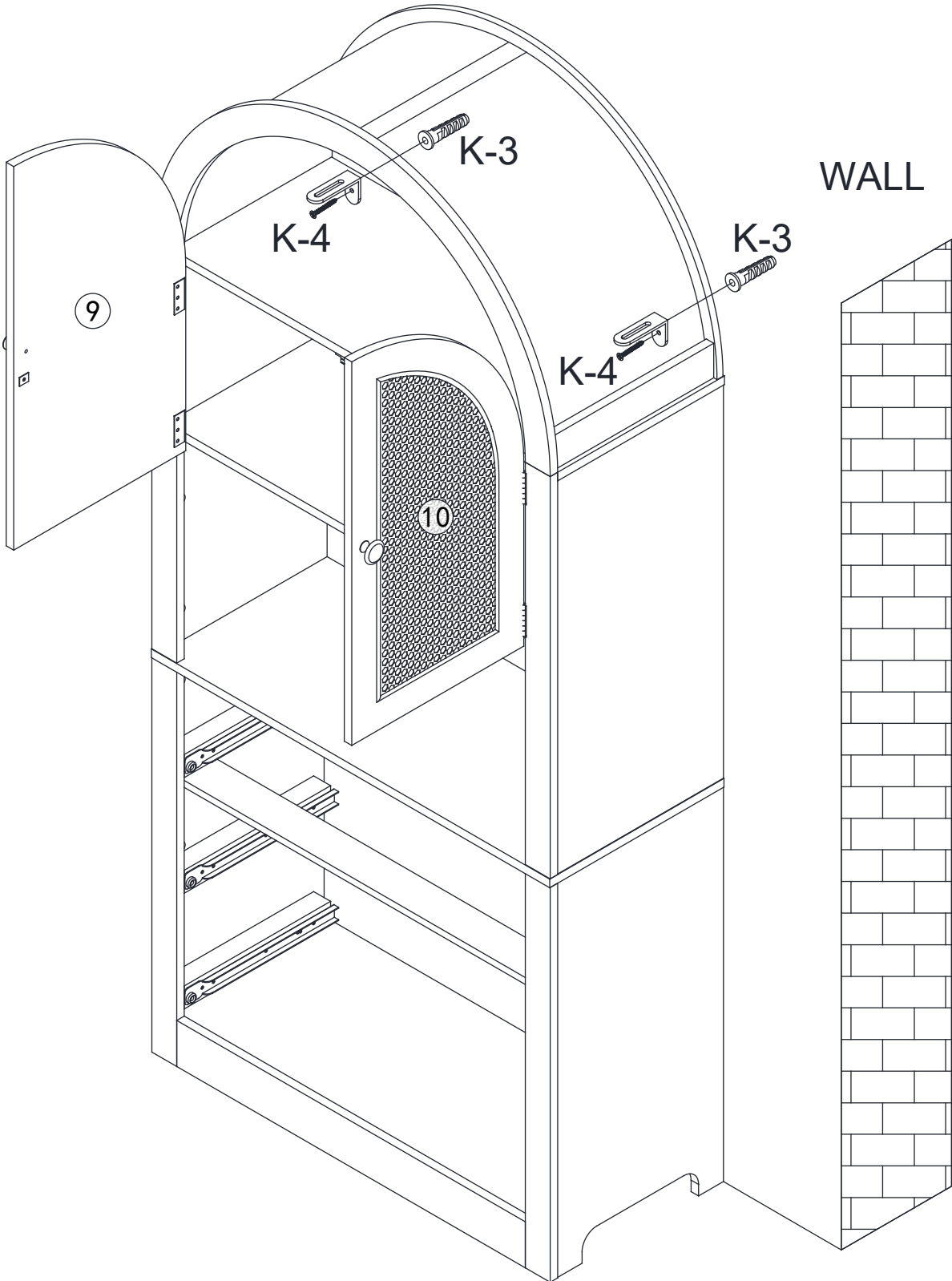
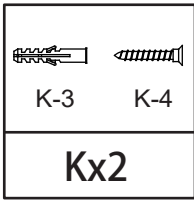

26.

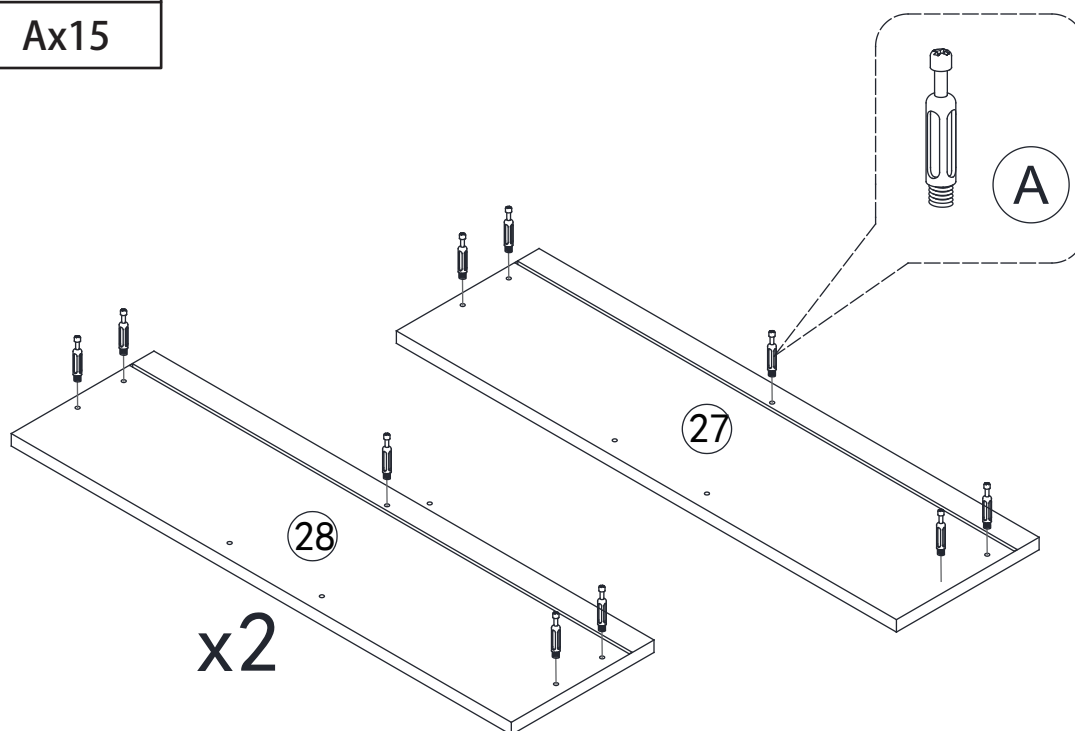
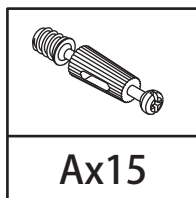

27.



28.

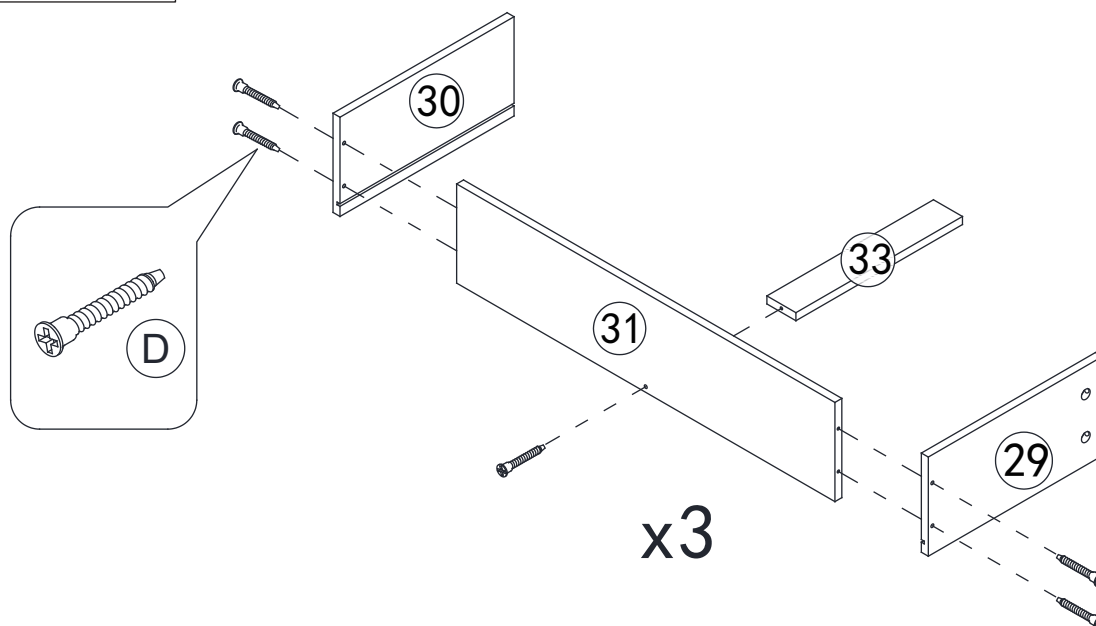
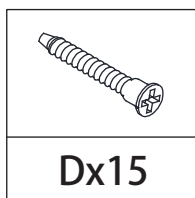

29.

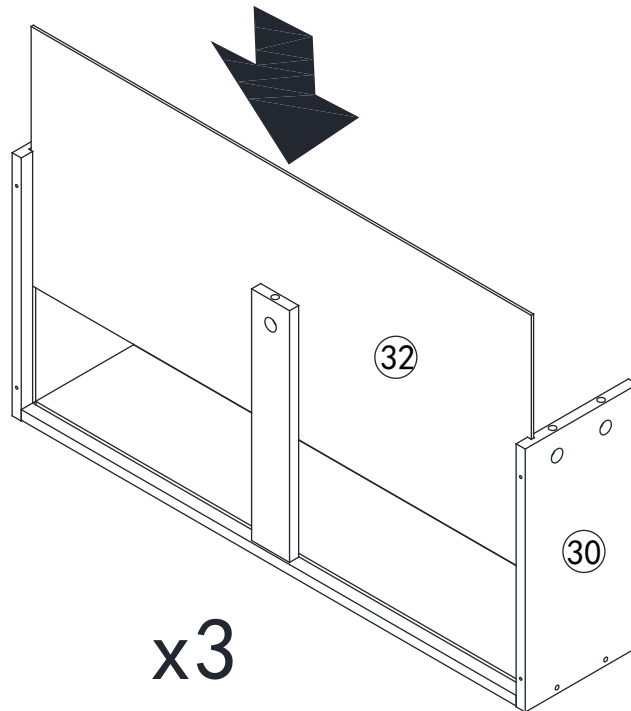

30.

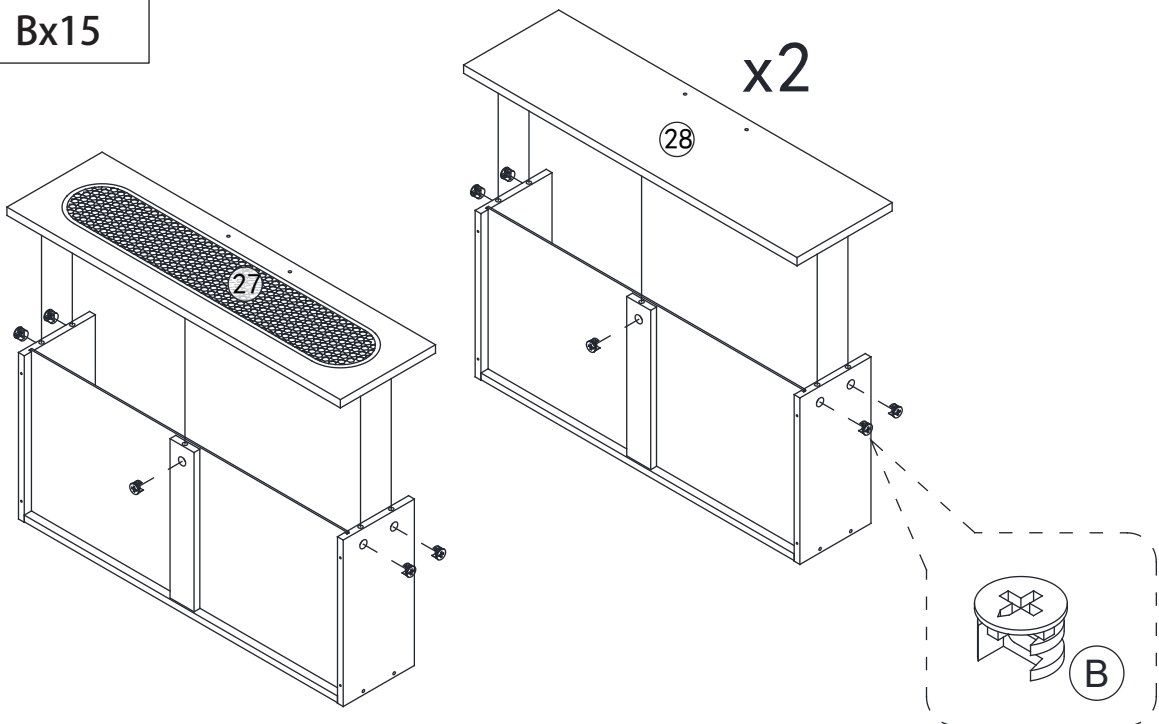
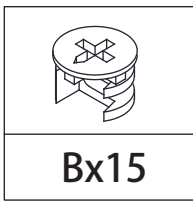

31.

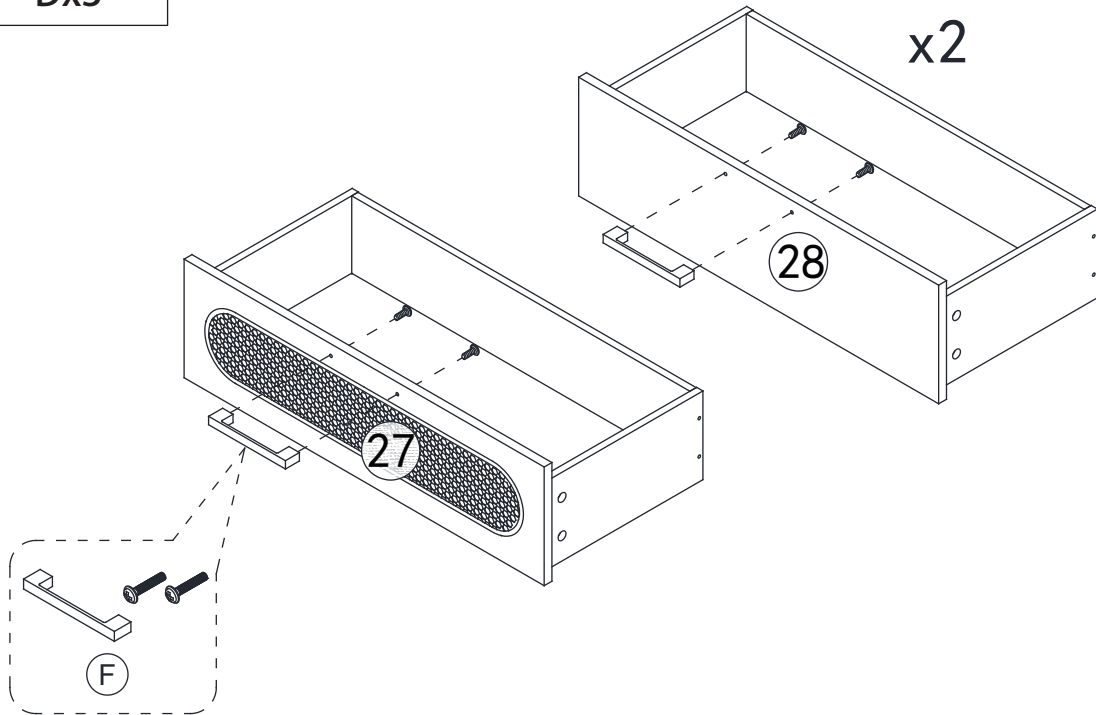
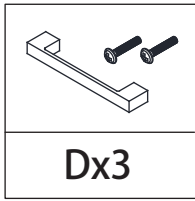

32.

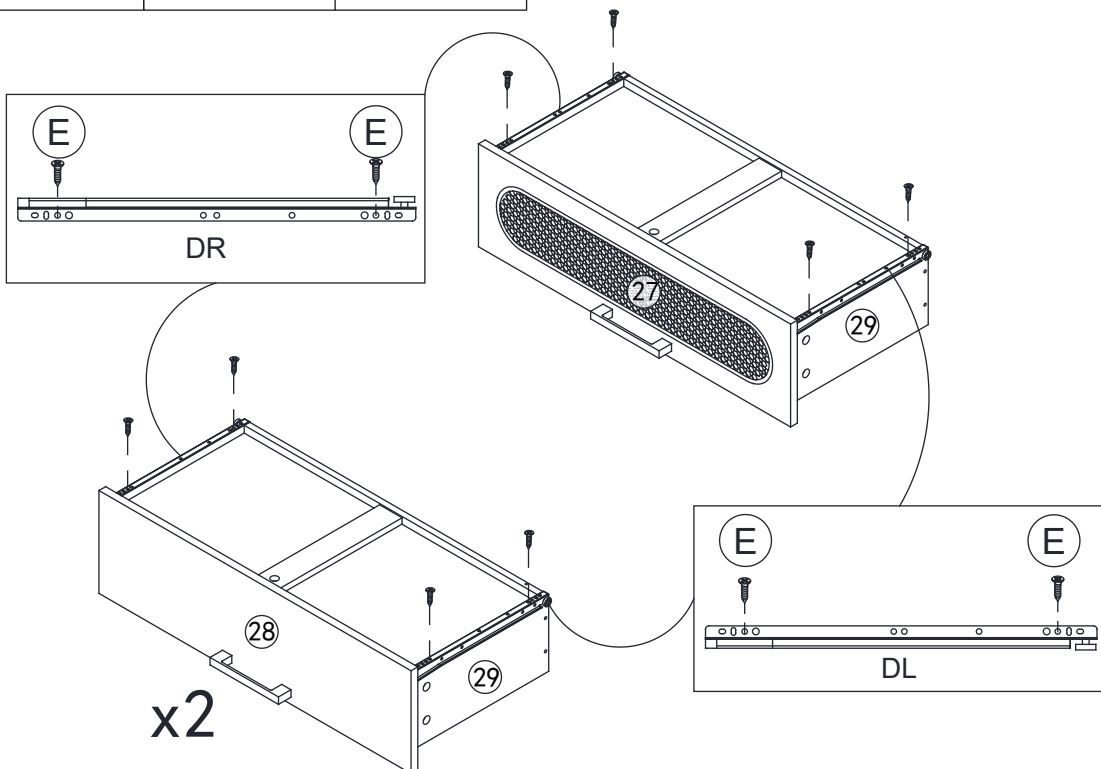
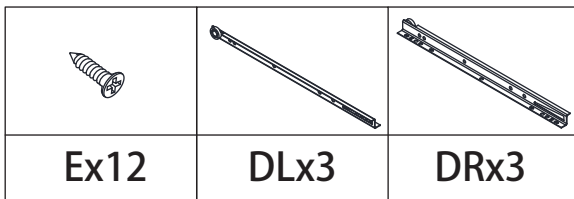

33.

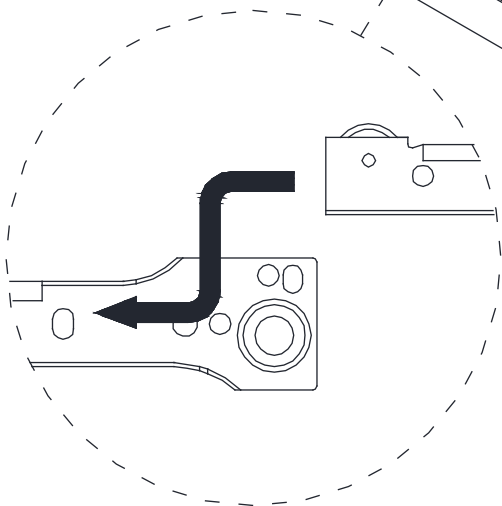
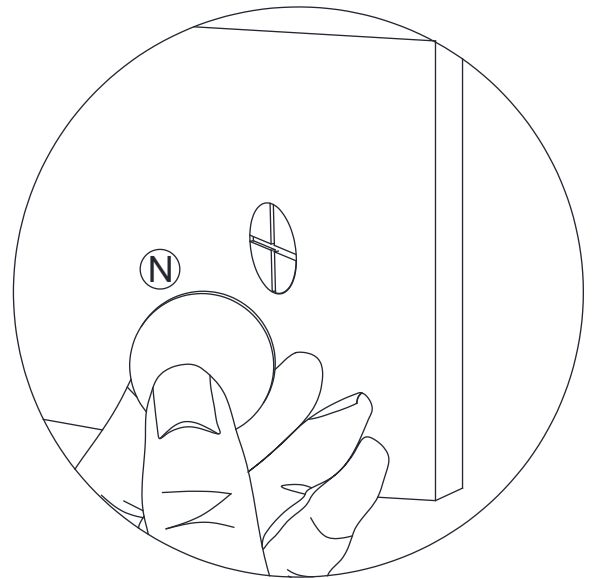
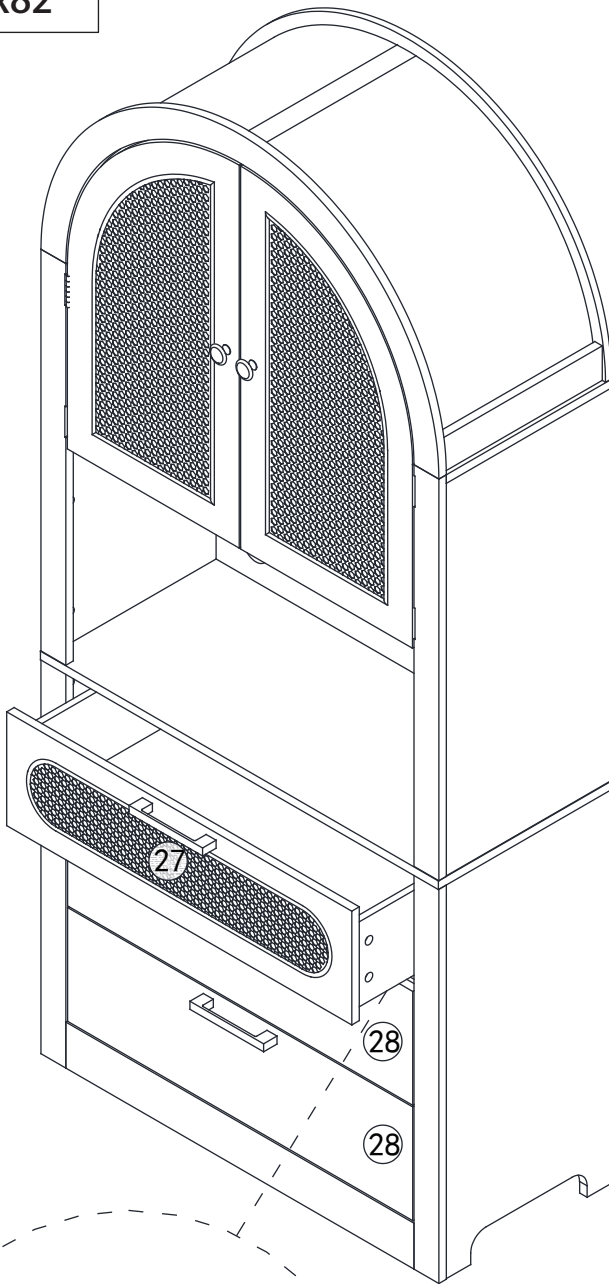
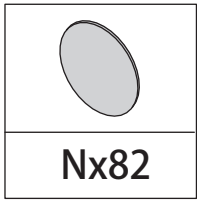

APP mode

This APP program requires that the minimum systems of your phones is Android 4.3 or iOS 8.0. No limit for mobile phone configuration.

You can download APP by scanning QR codes on IOS or Android systems. Use Apps with scanning function such as browser to scan the QR code.



Please open the strips lights control APP on your phone by which you can connect one or more LED strip through Bluetooth and able to set and control multiple LED strip.

Functions are listed as follows:

1. Adjust the brightness and color temperature of 60 kinds of colors for both colorful LED strip and monochrome LED strip;
2. Playing any music on your phone or in the Apps with music function would make the colors and brightness of the light change automatically according with the music rhythm, which is absolutely beautiful.
3. The multiple color change modes makes the color change automatically and would keep changing even the phone is disconnected with the strips lights.
4. Long distance control without direction restriction and multiple controls is allowed.
5. Once been connected, your phone would connect to the light strips automatically after you turn on your bluetooth.



Click to go to Group Management

Click to select device

Click to select the most recently connected device

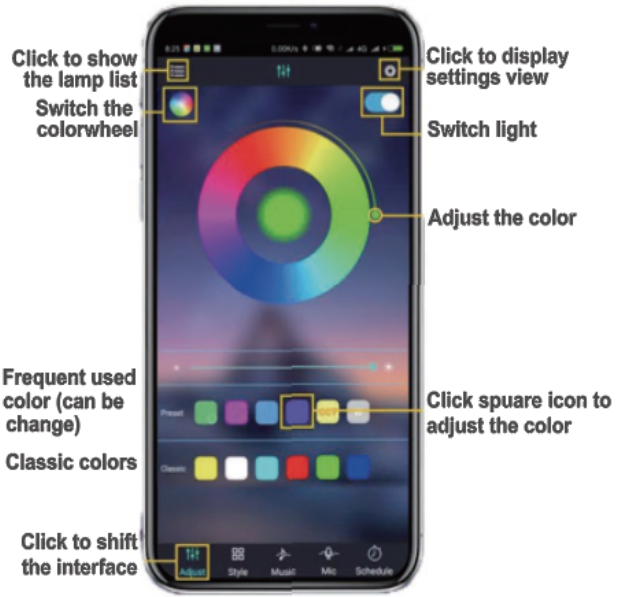

Click to show the lamp list

Switch the colorwheel

Click to display settings view

Switch light

Adjust the color

Frequent used color (can be change)

Classic colors

Click square icon to adjust the color

Click to shift the interface



Show the modified color

Adjust the RGB values separately

RGB value

Save the new values

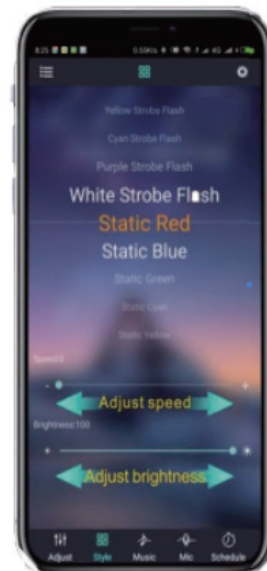

Scroll the selection mode



Color change according to the surrounding voices change

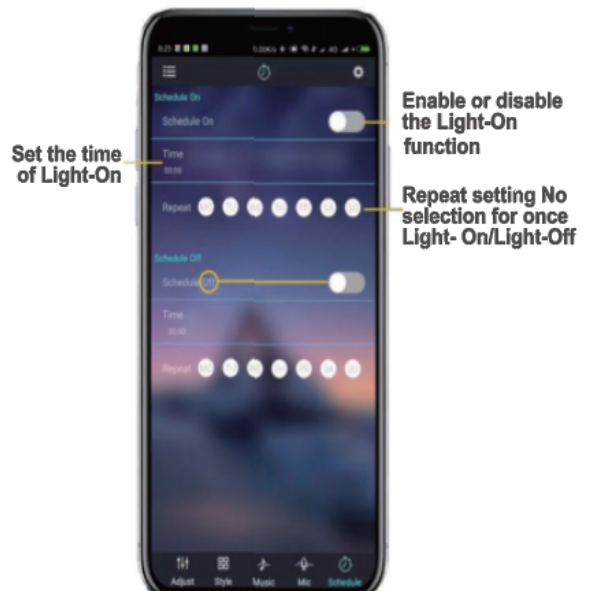
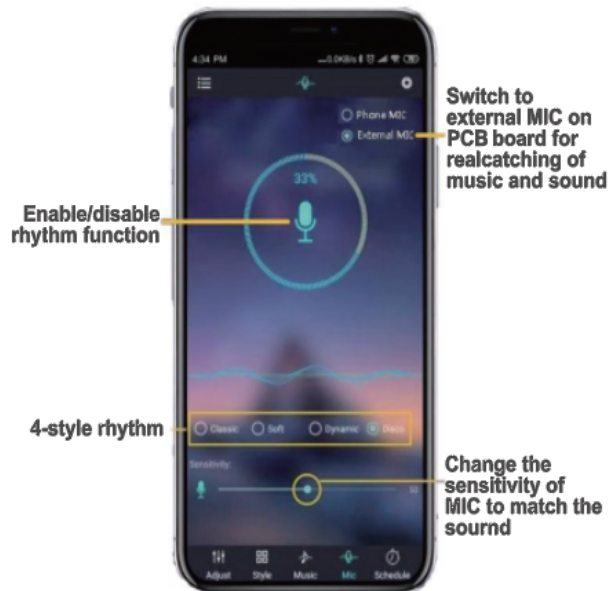
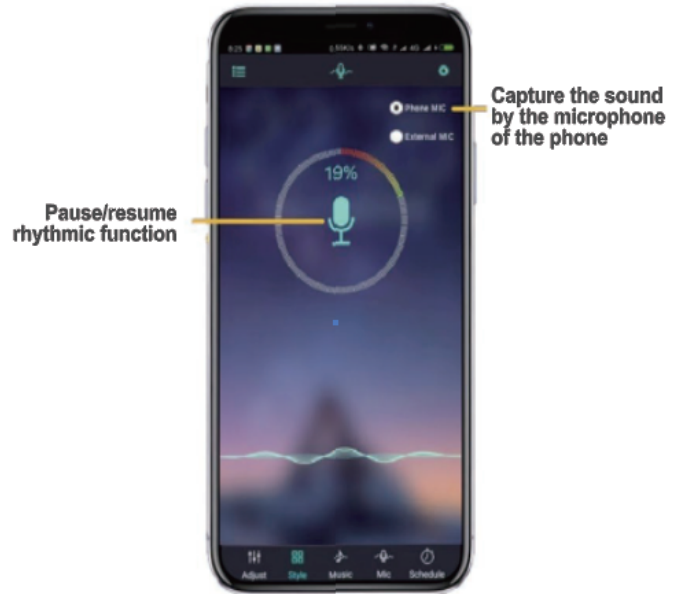
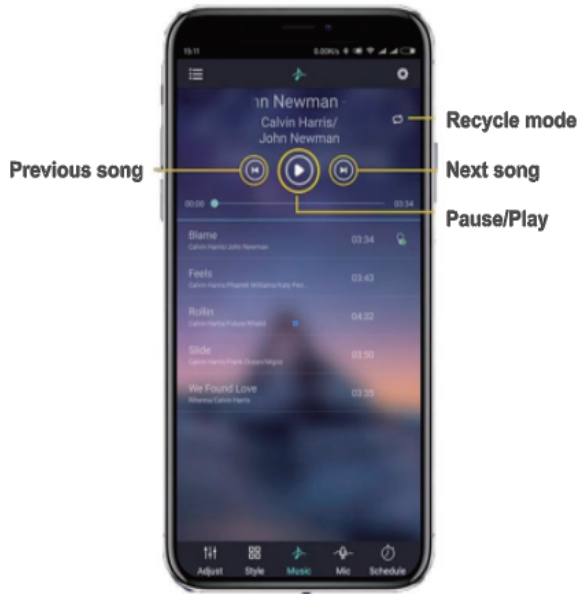

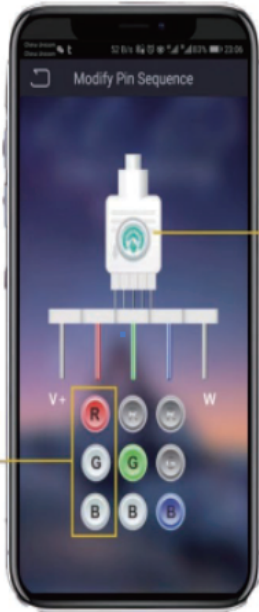

Click to save the new assignment

Change the real color- of this line



Common Troubleshooting

The controller was connected the power, but not light up

1.Check the input power supply: please use the power adapter that we equipped or other adapters with the same specification as ours . The input voltage must meet the voltage requirment of the strips lights.

When the input voltage is lower than requirement, the strips lights will not be turn on, while higher voltage may damage the circuit.

The output power of the adapter (KW value) must equals to, or higher than the power of the LED strips lights.

2.Check whether the connector is connected correctly with the strips lights. Make sure each interface is connected correctly

3.Check whether the remote control is open.

If the LED strips light able to light up, but the remote control does not work or can't control LED light.

1.Check whether the insulation sheet is removed from the remote control

2.Make sure the battery on the remote control is installed correctly

3.Ensure that the remote is working.

4.Try to replace the battery.

Attentions:

1.Light strip must be used under DC5V.

2.The light strips are IP65 waterproof and are suitable for indoor and outdoor. But the controller and power supply are not waterproof. So we all recommend hiding them away from water during use.

3.Make sure the surface you are going to paste strip is clean and dry.

Shenzhen ZKT Technology Co., Ltd.
 1/F, No. 101, Building B, No. 6, Tangwei Community Industrial Avenue,
 Fuhai Street, Bao'an District, Shenzhen, China



Certificate of Compliance

Certificate Number: ZKT-250306L3768C

Certificate's Holder : Xingning Lo Chen Photoelectric Co. , Ltd.
Zertifikatsinhaber : 602,6f, Zhenhua cultural and sports centre, the new China National Highway 205 of E San Tsuen, No. 2 Xingtian Road, Xingning

Manufacturer : Xingning Lo Chen Photoelectric Co. , Ltd.
Hersteller : 602,6f, Zhenhua cultural and sports centre, the new China National Highway 205 of E San Tsuen, No. 2 Xingtian Road, Xingning

Trade Mark : /
Warenzeichen

Product : Led Strip Light
Produkt

Model(s) : LC-5050,
Modell : LC-2835, LC-3528, LC-3014, LC-5730, LC-5630, LC-7020, LC-3535

Test Standard : EN IEC 62031:2020+A11:2021
Prüfnorm

This Attestation of Compliance is issued on a voluntary basis for electrical equipment below the voltage limits of Low Voltage Directive 2014/35/EU. The essential requirements are fulfilled accordingly based on the technical specifications applicable at the time of issuance. See also notes overleaf. It is only valid in connection with the test report number: ZKT-250306L3768S.



This Certificate of Conformity is based on single evaluation of the submitted sample(s) of the above mentioned product. It does not imply an assessment of the whole product and relevant Directives to be observed.

Shenzhen ZKT Technology Co., Ltd.
 1/F, No. 101, Building B, No. 6, Tangwei Community Industrial Avenue,
 Fuhai Street, Bao'an District, Shenzhen, China



Certificate of Compliance

Certificate Number: ZKT-250306L3766C

Certificate's Holder : Xingning Lo Chen Photoelectric Co. , Ltd.
 602,6f, Zhenhua cultural and sports centre, the new China National Highway 205 of E San Tsuen, No. 2 Xingtian Road, Xingning

Manufacturer : Xingning Lo Chen Photoelectric Co. , Ltd.
 602,6f, Zhenhua cultural and sports centre, the new China National Highway 205 of E San Tsuen, No. 2 Xingtian Road, Xingning

Trade Mark : /

Product : Led Strip Light

Model(s) : LC-5050,
 LC-2835, LC-3528, LC-3014, LC-5730, LC-5630, LC-7020, LC-3535

Test Standard : EN IEC 55015:2019+A11:2020
 EN IEC 61000-3-2:2019 + A1:2021 + A2:2024
 EN 61000-3-3:2013 + A1:2019 + A2:2021
 EN IEC 61547:2023

This Attestation of Compliance is issued on a voluntary basis for electrical equipment below the voltage limits of EMC Directive 2014/30/EU. The essential requirements are fulfilled accordingly based on the technical specifications applicable at the time of issuance. See also notes overleaf. It is only valid in connection with the test report number: ZKT-250306L3766E.



This Certificate of Conformity is based on single evaluation of the submitted sample(s) of the above mentioned product. It does not imply an assessment of the whole product and relevant . Directives to be observed.

Shenzhen ZKT Technology Co., Ltd.
 1/F, No. 101, Building B, No. 6, Tangwei Community Industrial Avenue,
 Fuhai Street, Bao'an District, Shenzhen, China



Certificate of Compliance

Certificate Number: ZKT-250306L3769C

Certificate's Holder : Xingning Lo Chen Photoelectric Co. , Ltd.
Address : 602,6f, Zhenhua cultural and sports centre, the new China National Highway 205 of E San Tsuen, No. 2 Xingtian Road, Xingning
Manufacturer : Xingning Lo Chen Photoelectric Co. , Ltd.
Address : 602,6f, Zhenhua cultural and sports centre, the new China National Highway 205 of E San Tsuen, No. 2 Xingtian Road, Xingning
Product : Led Strip Light
Trade Mark : /
Model(s) : LC-5050,
 LC-2835, LC-3528, LC-3014, LC-5730, LC-5630, LC-7020,
 LC-3535
Test Method : IEC 62321-5:2013 & IEC 62321-4:2013+A1:2017 &
 IEC 62321-7-2:2017 & IEC 62321-6:2015 & IEC 62321-8:2017
 & IEC 62321-3-1:2013 & IEC 62321-7-1:2015

The following products have been tested by us and found in conformity with the (RoHS) Directive 2011/65/EU Annex II amending Annex (EU)2015/863 and amending Annex (EU)2017/2102. It is possible to use CE Marking to demonstrate the conformity with this Directive. It is only valid in connection with the test report number: ZKT-250306L3769R. After preparation of the necessary technical documentation according the requirement of EN IEC 63000:2018 as well as the verification of conformity the CE marking as shown below can be affixed on the equipment.



This Certificate of Conformity is based on single evaluation of the submitted sample(s) of the above mentioned product. It does not imply an assessment of the whole product and relevant Directives to be observed.



Certificate of Conformity

Certificate Number : QQT202407105EC
Applicant : Shenzhen ShiKeShu Photoelectric Co., Ltd
Address : 1808, Building 11, Tiedong Logistics District, No. 3, Ping'an Avenue, Pinghu Community, Pinghu Street, Longgang District, Shenzhen
Manufacturer : Shenzhen ShiKeShu Photoelectric Co., Ltd
Address : 1808, Building 11, Tiedong Logistics District, No. 3, Ping'an Avenue, Pinghu Community, Pinghu Street, Longgang District, Shenzhen
Brand Name : N/A
Product : 24 Key LED Controller
Model : SKS-DS-03, SKS-DS-04, SKS-DS-05, SKS-BT-10, SKS-JZ-01, SKS-JZ-02, SKS-JZ-14, SKS-JZ-15, SKS-JZ-13, SKS-JZ-17, SKS-JZ-16, SKS-JZ-29, SKS-JZ-09, SKS-JZ-22, SKS-JZ-27, SKS-JZ-25, SKS-JZ-37, SKS-JZ-38, SKS-JZ-39, SKS-PJ-06, SKS-PJ-07

Essential requirement		Applied Standards	Report Number
Art.3.1(a)	Safety	EN IEC 62368-1:2020+A11:2020	QQT202407105-01SR
Art.3.1(a)	Health	EN IEC 62479:2010, EN 50663:2017	QQT202407105-02ER
Art.3.1(b)	EMC	ETSI EN 301 489-1 V2.2.3 (2019-11) ETSI EN 301 489-3 V2.3.2 (2023-01) EN 55032:2015+A11:2020+A1:2020 EN 55035:2017+A11:2020	QQT202407105-03ER
Art.3.2	Radio	ETSI EN 300 220-1 V3.1.1 (2017-02) ETSI EN 300 220-2 V3.2.1 (2018-06)	QQT202407105-04ER

The EUT described above has been tested by us with the listed standards and found in compliance with the council Radio Equipment Directive (RED) 2014/53/EU. It is possible to use CE marking to demonstrate the compliance with this RE Directive.

The certificate applies to the tested sample above mentioned only and shall not imply an assessment of the whole production. It is only valid in connection with the test report number as above listed.



Shenzhen Qiqing Technology Co., Ltd.

Room.802, Zhongcheng Sci-tech Building, No.543, Jinbi Road, Biling Street,
Pingshan District, Shenzhen, Guangdong, China

WEB: www.qq-lab.com

Email: Serviec@qq-lab.com

Tel: 0755-28266974