

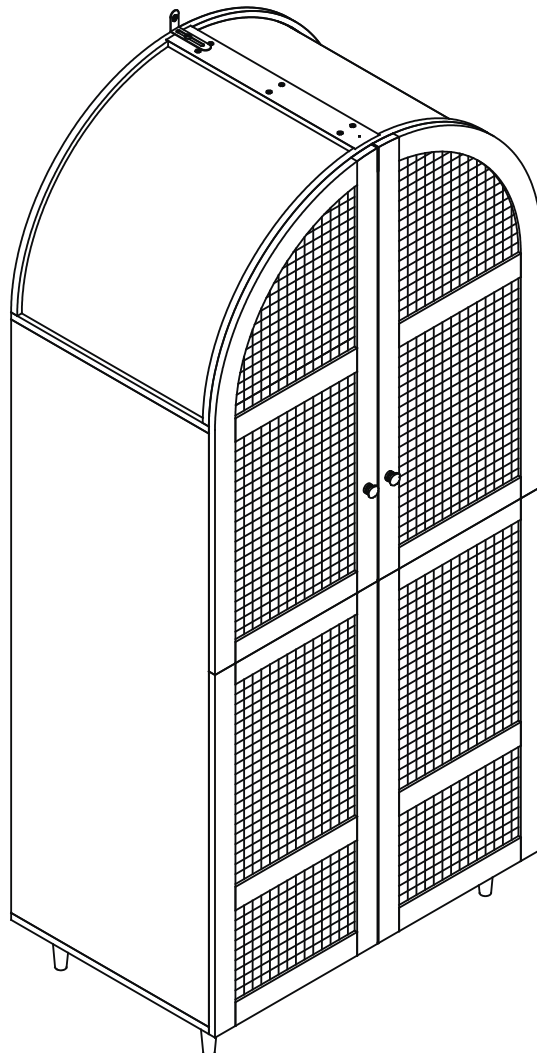

# N621P315842D& N621P315843D

Product manual  
Gebrauchsanweisung  
Manuel du produit  
Manual del producto  
Manuale del prodotto

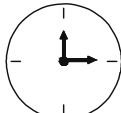
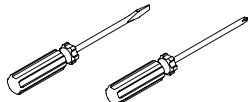

Sets werden oft in mehreren Kartons verschickt und können im Abstand von ein oder zwei Tagen beiliegen eintreffen.  
Sets are often shipped in multiple boxes and may arrive within a day or two of each other.  
Les ensembles sont souvent expédiés dans plusieurs boîtes et peuvent arriver à un jour ou deux d'intervalle.

 2PERS	 60 MIN	<b>Tool Required</b> 
--	---	---



[DE]

**Warnung:** Lesen Sie die Anleitung vor dem Zusammenbau bitte vollständig durch. Überprüfen Sie, ob Sie alle auf den Seiten aufgeführten Komponenten und Werkzeuge haben.

**Warnung:** Legen Sie alle Teile auf eine ebene Fläche. Legen Sie eine weiche Decke oder Ähnliches darunter, um sie vor Kratzern oder Flecken zu schützen. Vermeiden Sie es, Komponenten über den Boden zu ziehen oder zu schieben.

**Warnung:** Überprüfen Sie regelmäßig alle Beschläge und Befestigungen, um sicherzustellen, dass sie sicher sind und um Unfälle zu vermeiden. Wenn Teile fehlen, kaputt, beschädigt oder abgenutzt sind, verwenden Sie das Produkt nicht weiter, bis es mit vom Hersteller autorisierten Teilen repariert wurde.

**Warnung:** Lassen Sie Kinder nicht auf die Möbel klettern, da dies zum Umkippen und zu schweren Verletzungen führen kann. Bauen Sie die Möbel außerhalb der Reichweite von Kindern zusammen.

**Warnung:** Stellen Sie die Möbel nicht in die Nähe von Feuerquellen oder heißen Gegenständen, um Brandgefahr zu vermeiden.

**Warnung:** Reinigen Sie die Möbel mit einem feuchten Tuch oder Alkohol. Verwenden Sie keine Reinigungsmittel mit ätzenden Chemikalien.

**Warnung:** Dieses Produkt ist mit einer Kippschutzvorrichtung ausgestattet. Bitte installieren Sie diese Vorrichtung unbedingt, um unnötige Verletzungen durch Umkippen zu vermeiden.

[EN]

**Warning:** Please read instructions fully before starting assembly. Check you have all the components and tools listed on pages.

**Warning:** Please place all parts on a flat surface. Place a soft blanket or similar underneath to protect against scratches or stains. Avoid dragging or sliding components across the floor.

**Warning:** Regularly check all fittings and fastenings to ensure they are secure and to prevent accidents. If any parts are missing, broken, damaged, or worn, discontinue use of the product until repairs have been made using factory authorized parts.

**Warning:** Do not allow children to climb on the furniture as this may result in tipping and serious personal injury. Assemble the furniture away from the reach of children.

**Warning:** Do not place furniture close to fire sources or high-temperature objects to avoid the risk of fire.

**Warning:** Clean furniture with a damp cloth or alcohol, avoid using cleaning agents containing corrosive chemicals.

**Warning:** This product is equipped with an anti-tilt device. Please be sure to install this device to prevent unnecessary injuries caused by tipping.

[FR]

**Avertissement :** Veuillez lire entièrement les instructions avant de commencer l'assemblage. Vérifiez que vous disposez de tous les composants et outils répertoriés sur les pages.

**Avertissement :** Veuillez placer toutes les pièces sur une surface plane. Placez une couverture douce ou similaire en dessous pour les protéger des rayures ou des taches. Évitez de faire glisser les composants sur le sol.

**Avertissement :** Vérifiez régulièrement tous les raccords et fixations pour vous assurer qu'ils sont bien fixés et pour éviter les accidents. Si des pièces manquent, sont cassées, endommagées ou usées, cessez d'utiliser le produit jusqu'à ce que des réparations aient été effectuées à l'aide de pièces autorisées par l'usine.

**Avertissement :** Ne laissez pas les enfants grimper sur les meubles car cela pourrait entraîner un basculement et des blessures graves. Assemblez les meubles hors de portée des enfants.

**Avertissement :** Ne placez pas les meubles à proximité de sources de feu ou d'objets à haute température pour éviter tout risque d'incendie.



**Avertissement** : Nettoyez les meubles avec un chiffon humide ou de l'alcool, évitez d'utiliser des produits de nettoyage contenant des produits chimiques corrosifs.

**Avertissement** : Ce produit est équipé d'un dispositif anti-basculement. Assurez-vous d'installer ce dispositif pour éviter les blessures inutiles causées par un basculement.

[IT]

**Attenzione**: leggere attentamente le istruzioni prima di iniziare il montaggio. Verificare di avere tutti i componenti e gli strumenti elencati nelle pagine.

**Attenzione**: posizionare tutte le parti su una superficie piana. Posizionare una coperta morbida o simile sotto per proteggere da graffi o macchie. Evitare di trascinare o far scivolare i componenti sul pavimento.

**Attenzione**: controllare regolarmente tutti i raccordi e i dispositivi di fissaggio per assicurarsi che siano sicuri e per prevenire incidenti. Se alcune parti sono mancanti, rotte, danneggiate o usurate, interrompere l'uso del prodotto fino a quando non siano state eseguite le riparazioni utilizzando parti autorizzate dalla fabbrica.

**Attenzione**: non consentire ai bambini di arrampicarsi sui mobili poiché ciò potrebbe causare ribaltamenti e gravi lesioni personali. Montare i mobili lontano dalla portata dei bambini.

**Attenzione**: non posizionare i mobili vicino a fonti di fuoco o oggetti ad alta temperatura per evitare il rischio di incendio.

**Attenzione**: pulire i mobili con un panno umido o alcol, evitare di utilizzare detergenti contenenti sostanze chimiche corrosive.

**Attenzione**: questo prodotto è dotato di un dispositivo antiribaltamento. Assicurarsi di installare questo dispositivo per prevenire lesioni inutili causate dal ribaltamento.

[ES]

**Advertencia**: Lea las instrucciones completamente antes de comenzar el montaje. Compruebe que tiene todos los componentes y herramientas que se enumeran en las páginas.

**Advertencia**: Coloque todas las piezas sobre una superficie plana. Coloque una manta suave o algo similar debajo para protegerlas de rayones o manchas. Evite arrastrar o deslizar los componentes por el piso.

**Advertencia**: Verifique regularmente todos los accesorios y fijaciones para asegurarse de que estén seguros y evitar accidentes. Si falta alguna pieza, está rota, dañada o desgastada, deje de usar el producto hasta que se hayan realizado las reparaciones con piezas autorizadas de fábrica.

**Advertencia**: No permita que los niños se suban a los muebles, ya que esto puede provocar que se vuelquen y lesiones personales graves. Monte los muebles fuera del alcance de los niños.

**Advertencia**: No coloque los muebles cerca de fuentes de fuego u objetos de alta temperatura para evitar el riesgo de incendio.



**Advertencia**: Limpie los muebles con un paño húmedo o alcohol, evite usar agentes de limpieza que contengan químicos corrosivos.

**Advertencia**: Este producto está equipado con un dispositivo antivuelco. Asegúrese de instalar este dispositivo para evitar lesiones innecesarias causadas por vuelcos.

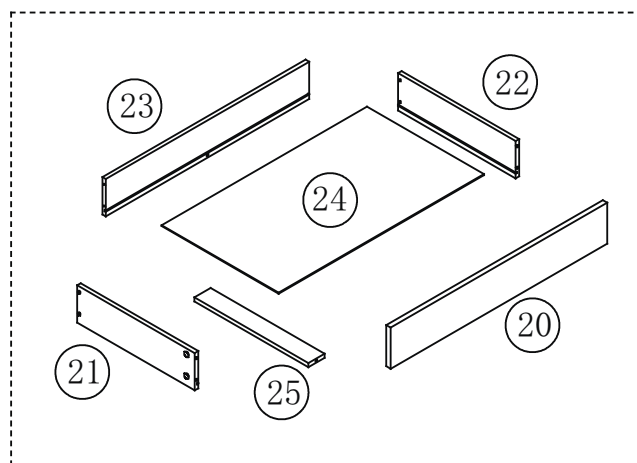
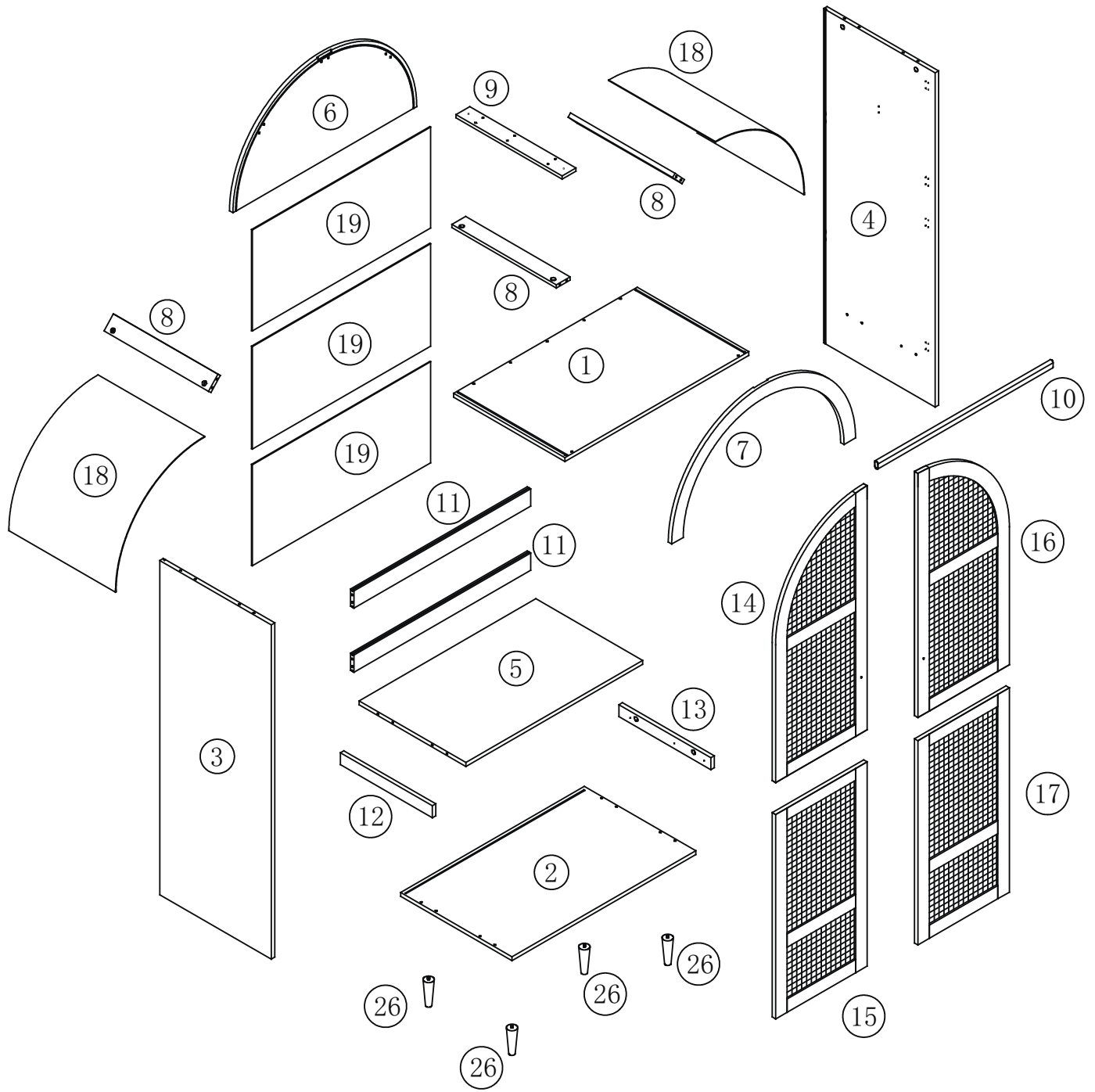
<b>Importeur</b>	Decobus Handel GmbH
<b>Adresse</b>	Innungsstraße 9, 21244 Buchholz, Deutschland
<b>URL</b>	<a href="https://www.decobusgroup.de">https://www.decobusgroup.de</a>
<b>Hersteller</b>	Fuzhou Homeasy Co.,Ltd
<b>Adresse</b>	Unit 1102, NO.1 Building,Chai Tai Plaza,NO.18 Wuyi Zhong Road,Fuzhou,China
<b>Email/URL</b>	pony@homeasyLtd.cn
<b>Partienummer</b>	N621P315842D N621P315843D
<b>Hergestellt in</b>	China
<b>EC REP</b>	Decobus Handel GmbH Innungsstraße 9, 21244 Buchholz, Deutschland <a href="https://www.decobusgroup.de">https://www.decobusgroup.de</a>

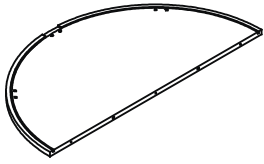
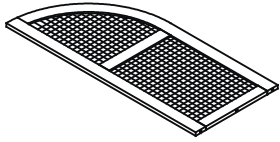
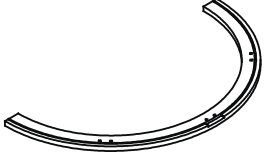
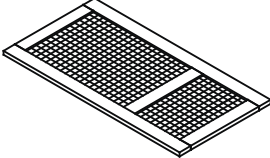
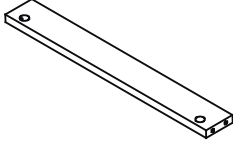
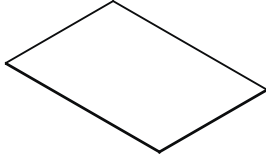
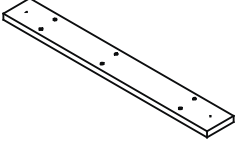
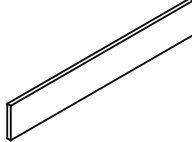
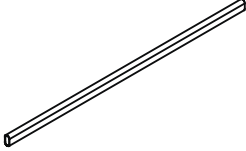
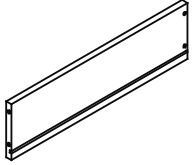
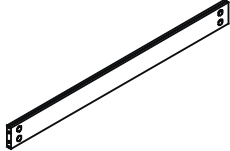
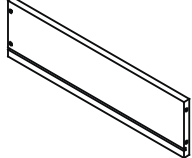
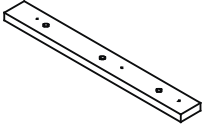
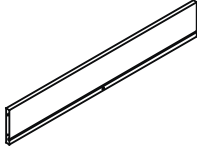
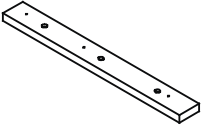
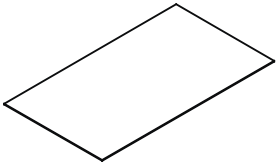
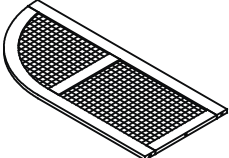
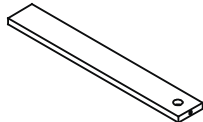
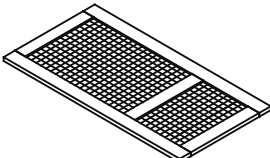

# N621P315842D

NO.	PARTS	QTY		NO.	PARTS	QTY
⑥		1		①⑥		2
⑦		1		①⑦		1
⑧		3		①⑨		3
⑨		1		②①		1
⑩		1		②②		1
⑪		2		②③		1
⑫		1		②④		1
⑬		1		②⑤		1
⑭		1		②⑥		1
⑮		1		②⑦		4

# N621P315843D

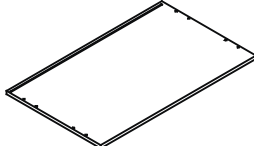
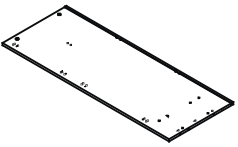
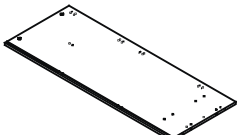
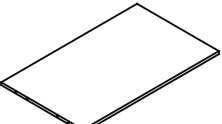
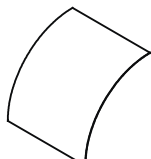
NO.	PARTS	QTY
①		1
②		1
③		1
④		1
⑤		1
⑱		2

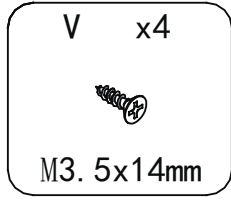
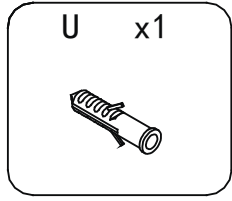
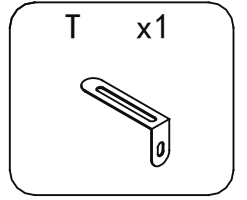
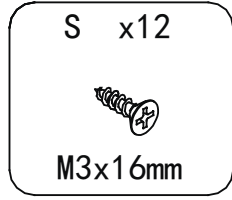
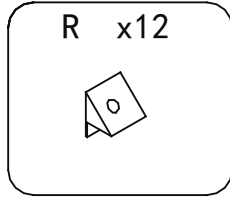
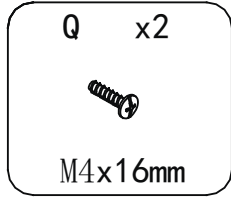
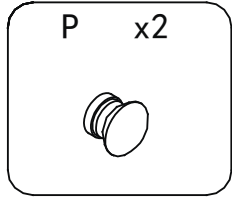
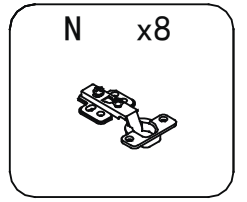
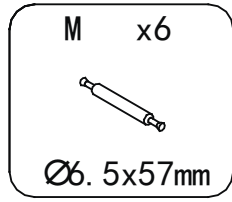
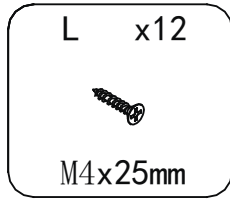
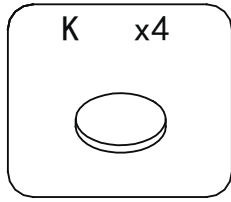
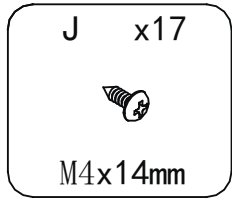
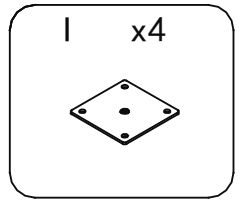
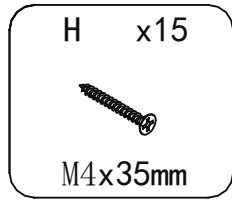
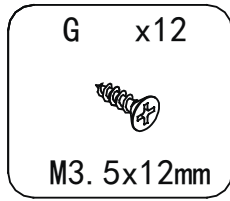
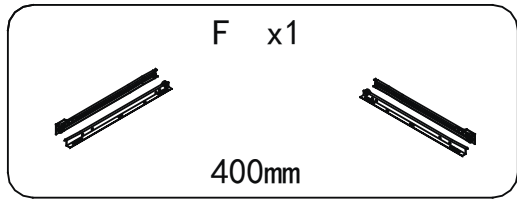
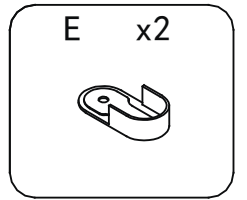
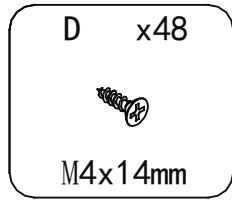
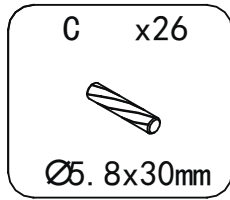
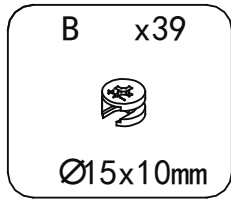
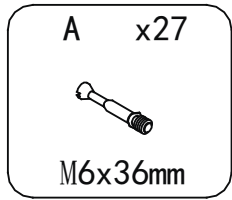

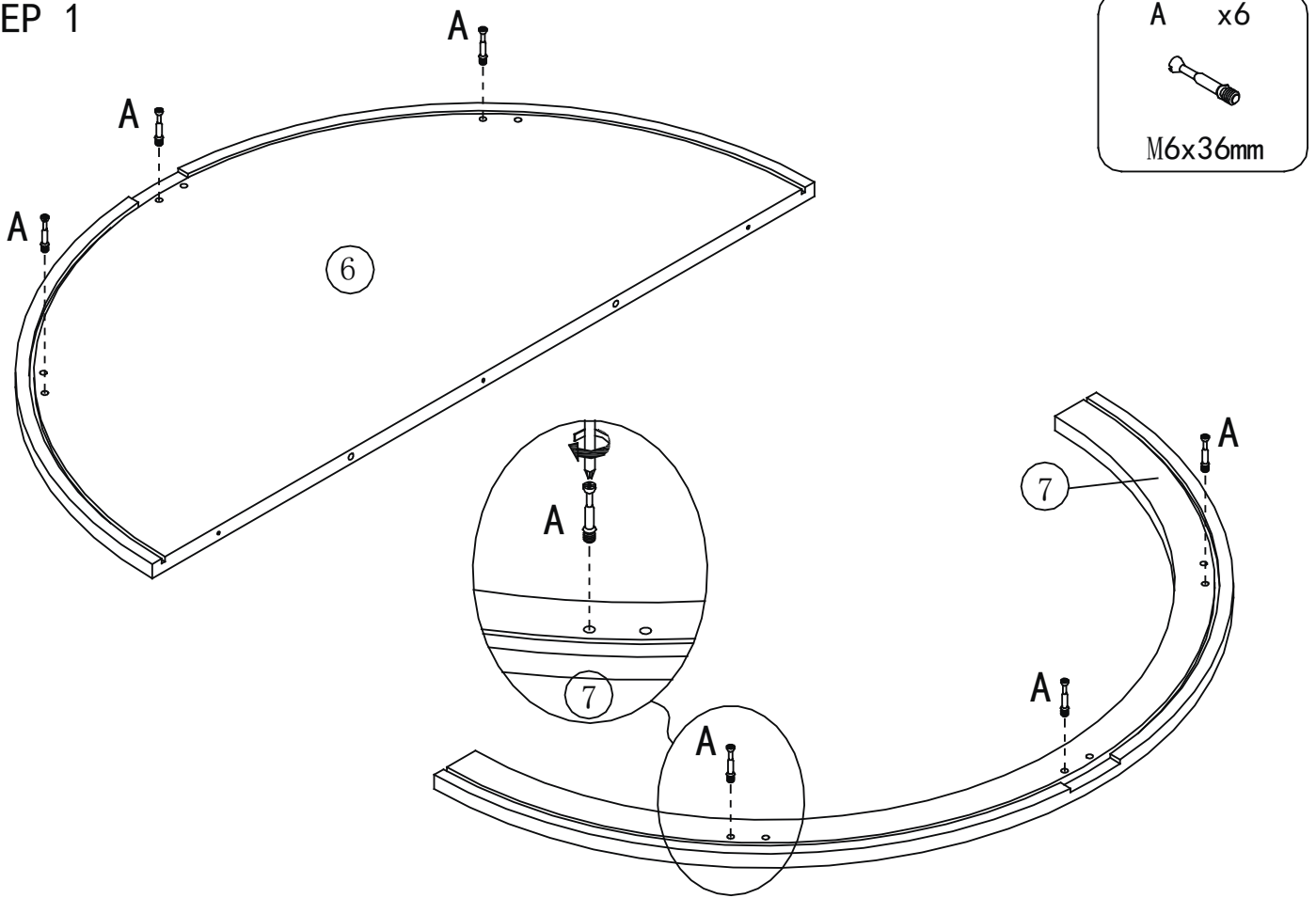

# STEP 1

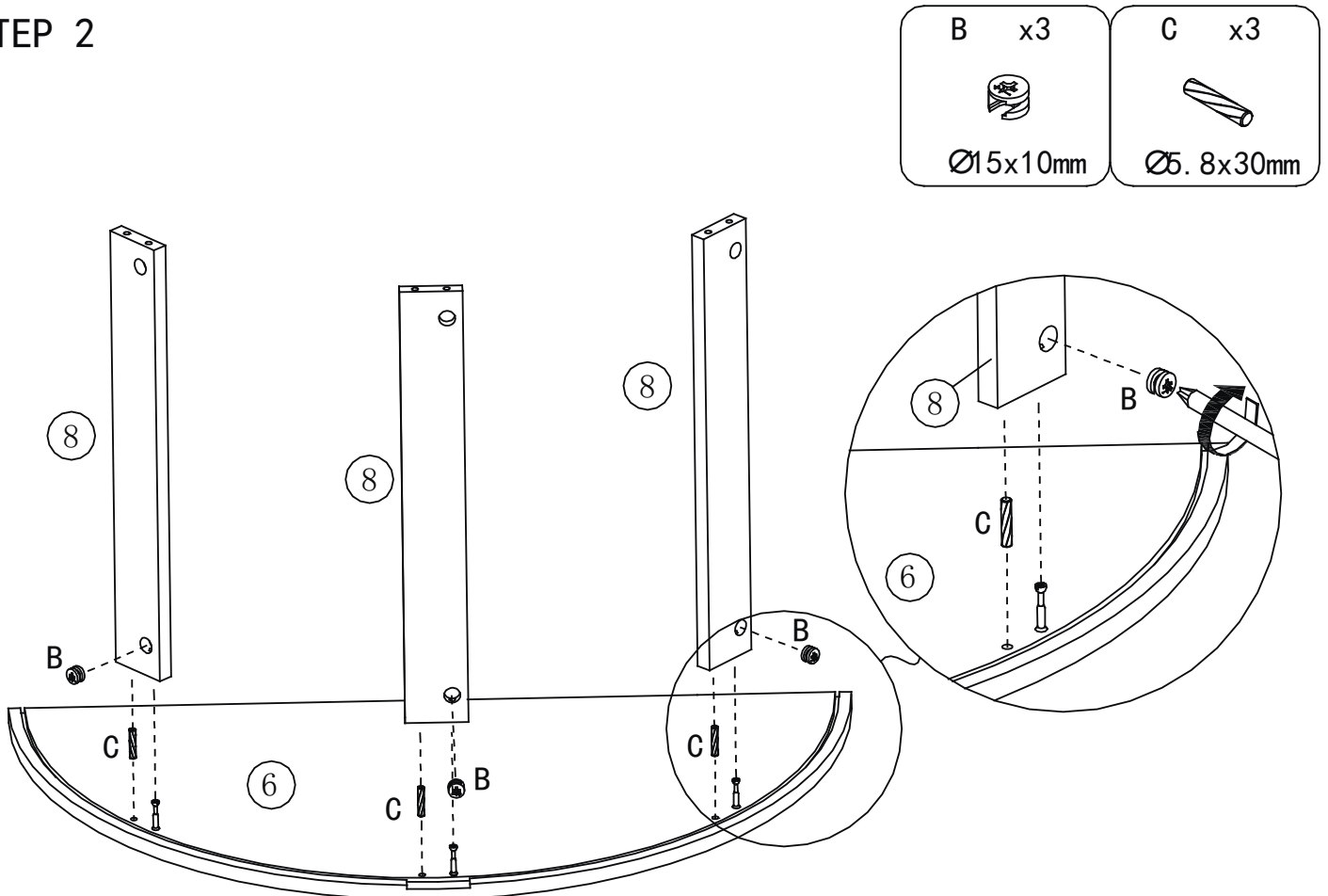

# STEP 2



### STEP 3

<b>B</b> x3  Ø15x10mm	<b>C</b> x3  Ø5.8x30mm
--	---

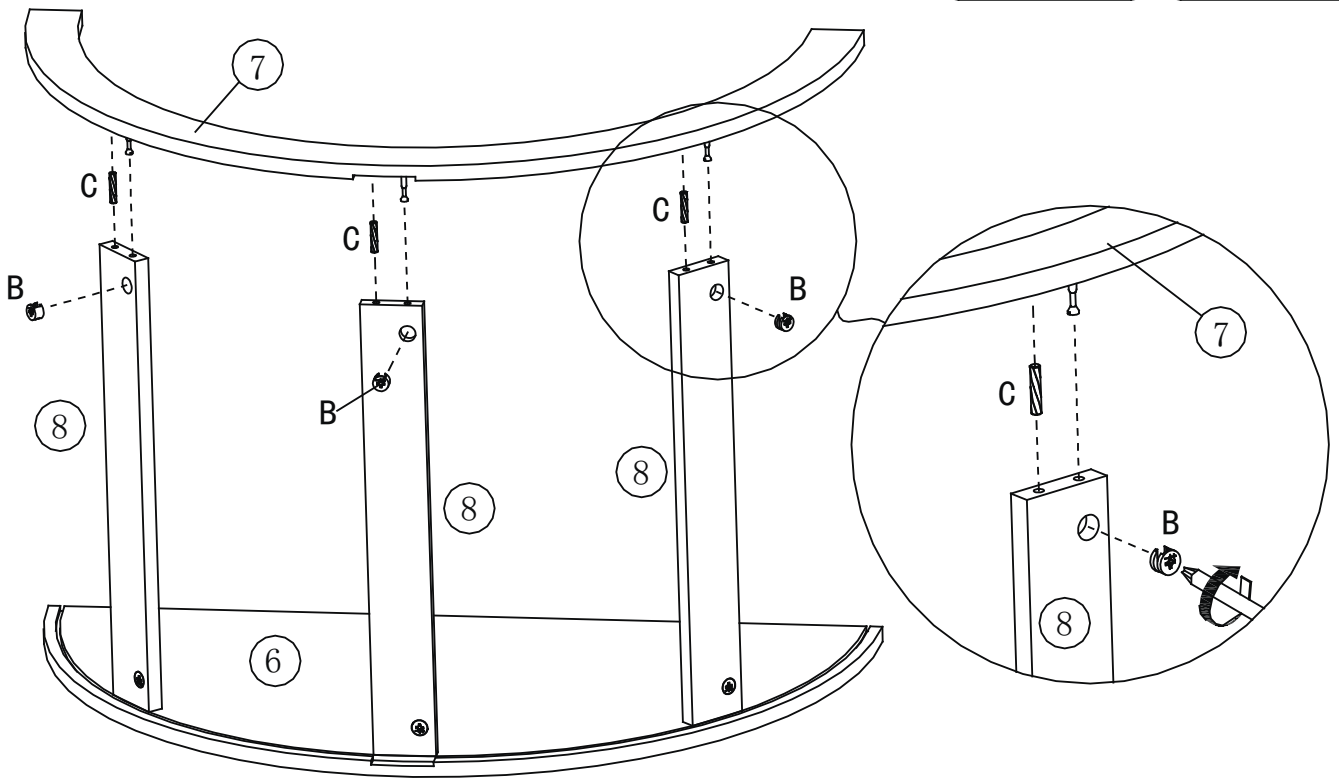

### STEP 4

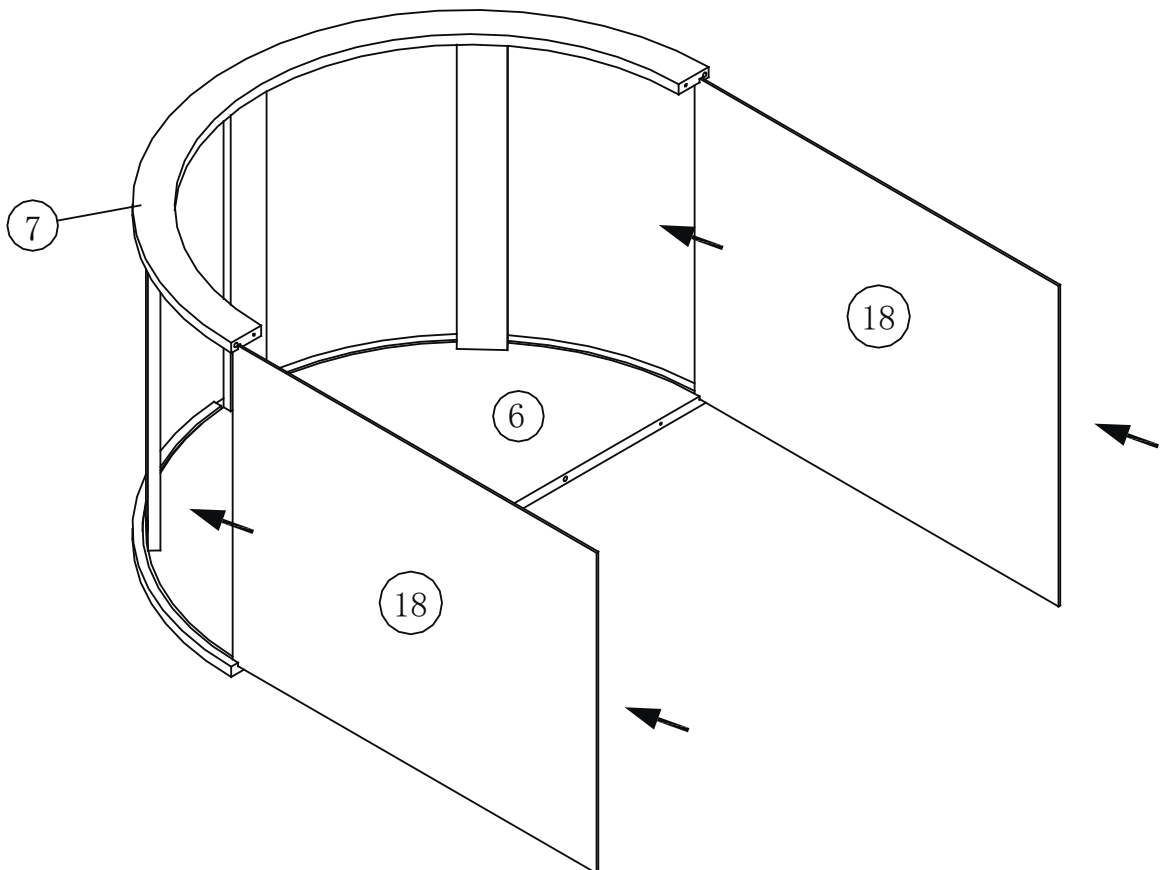

# STEP 5

A x4



M6x36mm

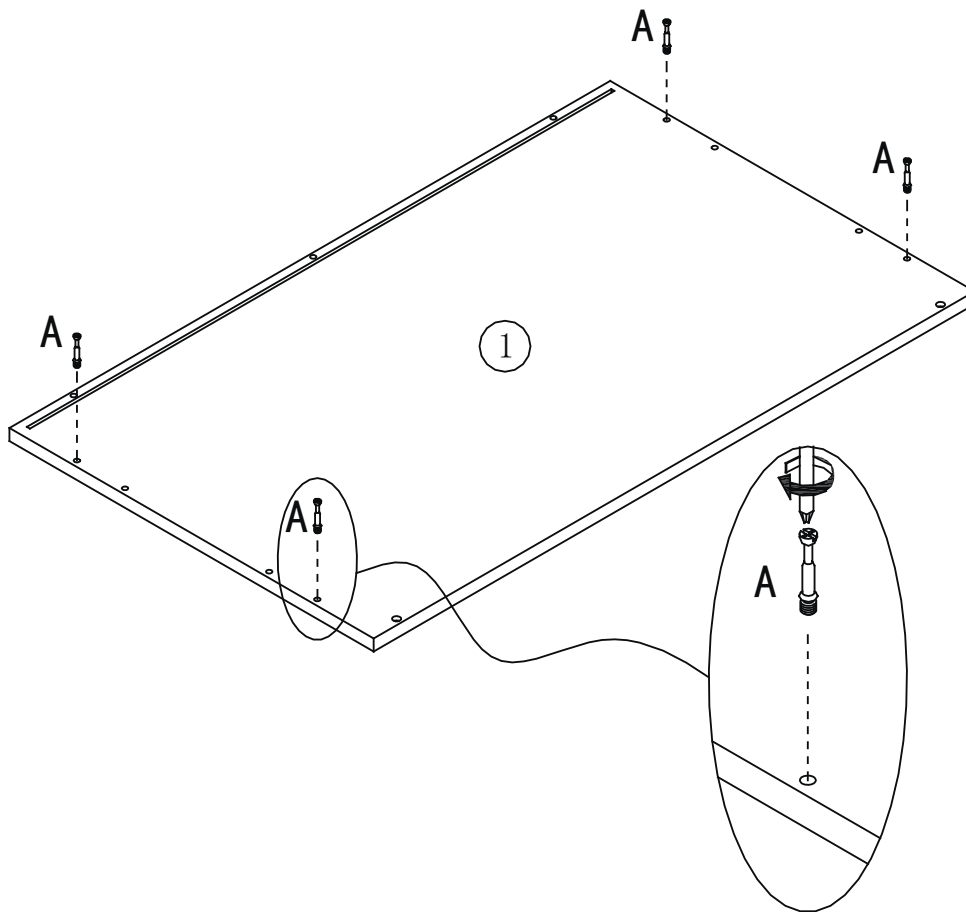

# STEP 6

C x4



Ø5.8x30mm

H x5



M4x35mm

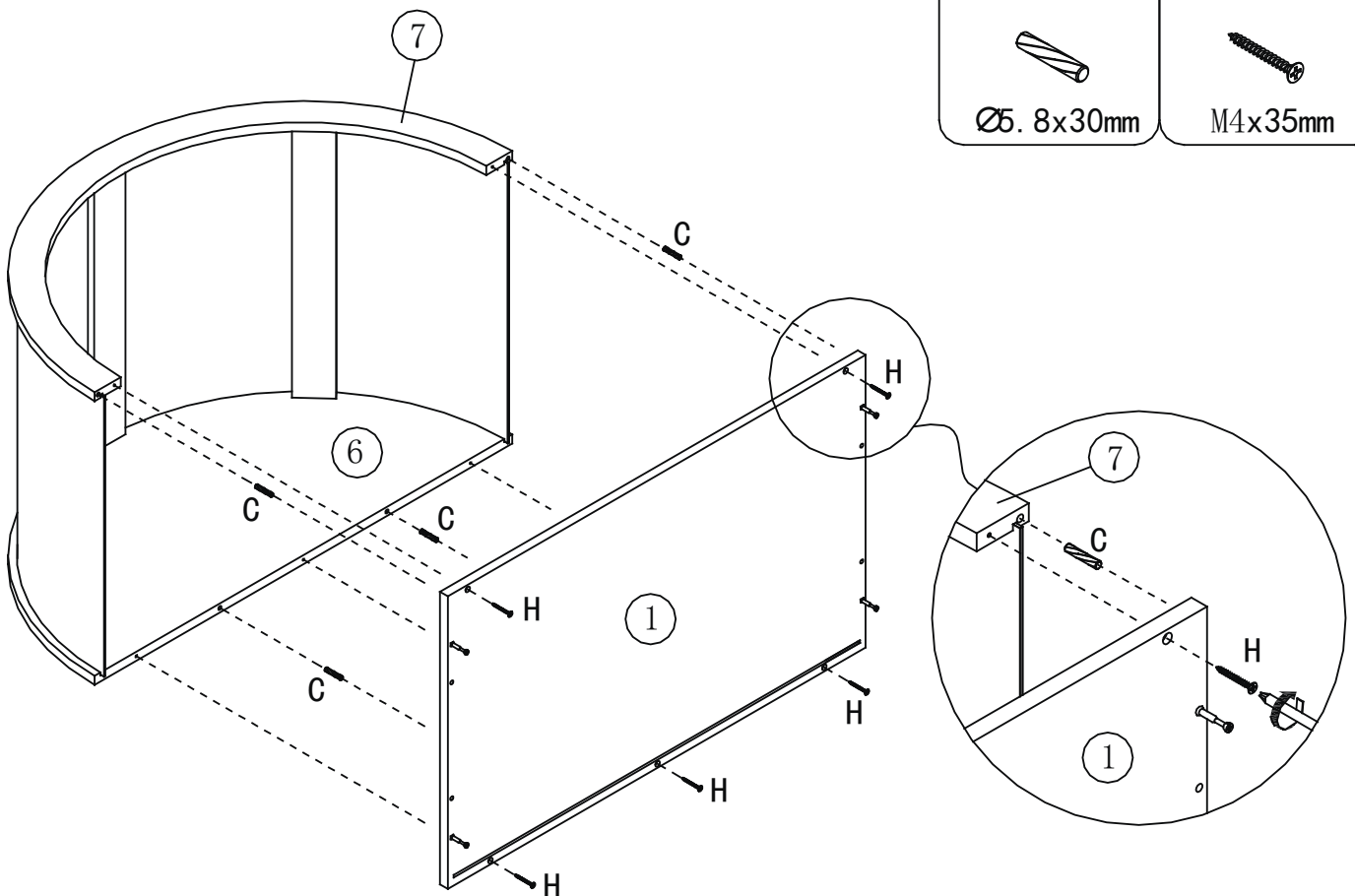

# STEP 7

L x6



M4x25mm

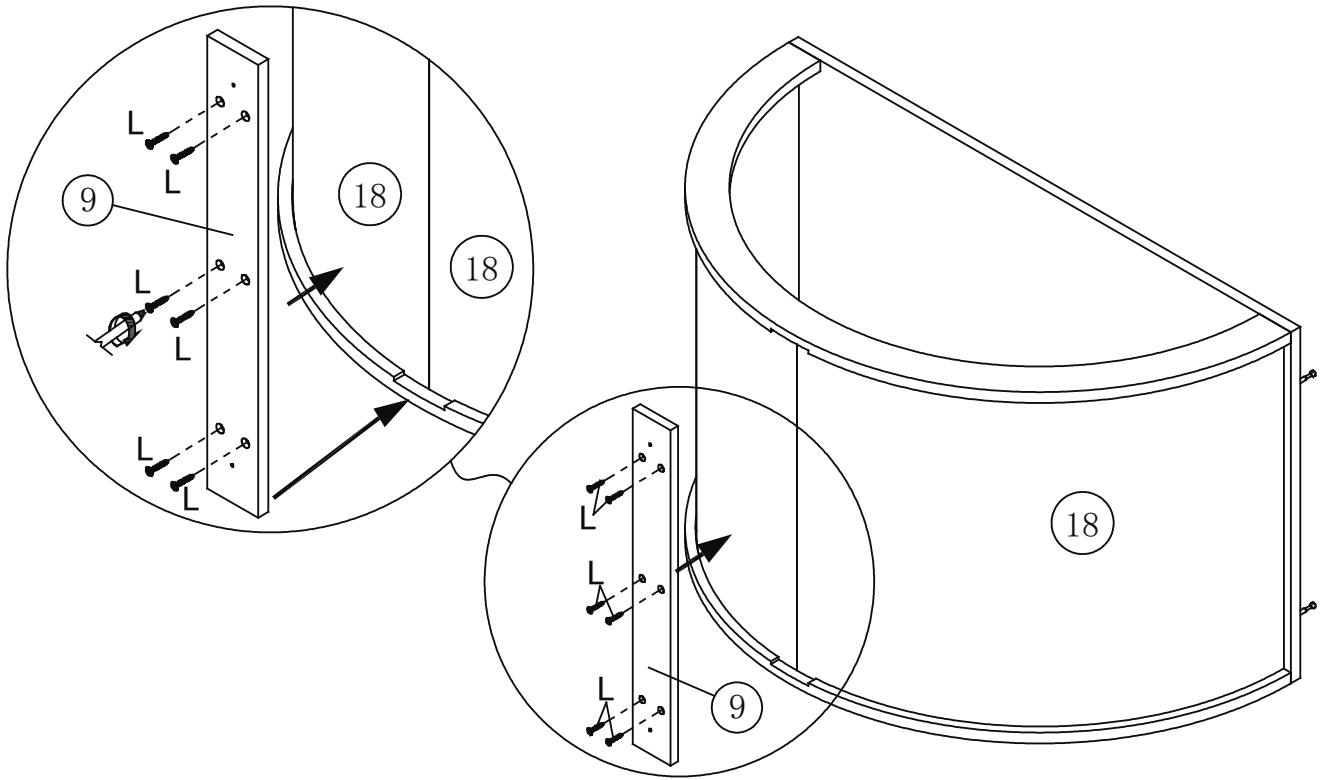

# STEP 8

C x4



Ø5.8x30mm

L x6



M4x25mm

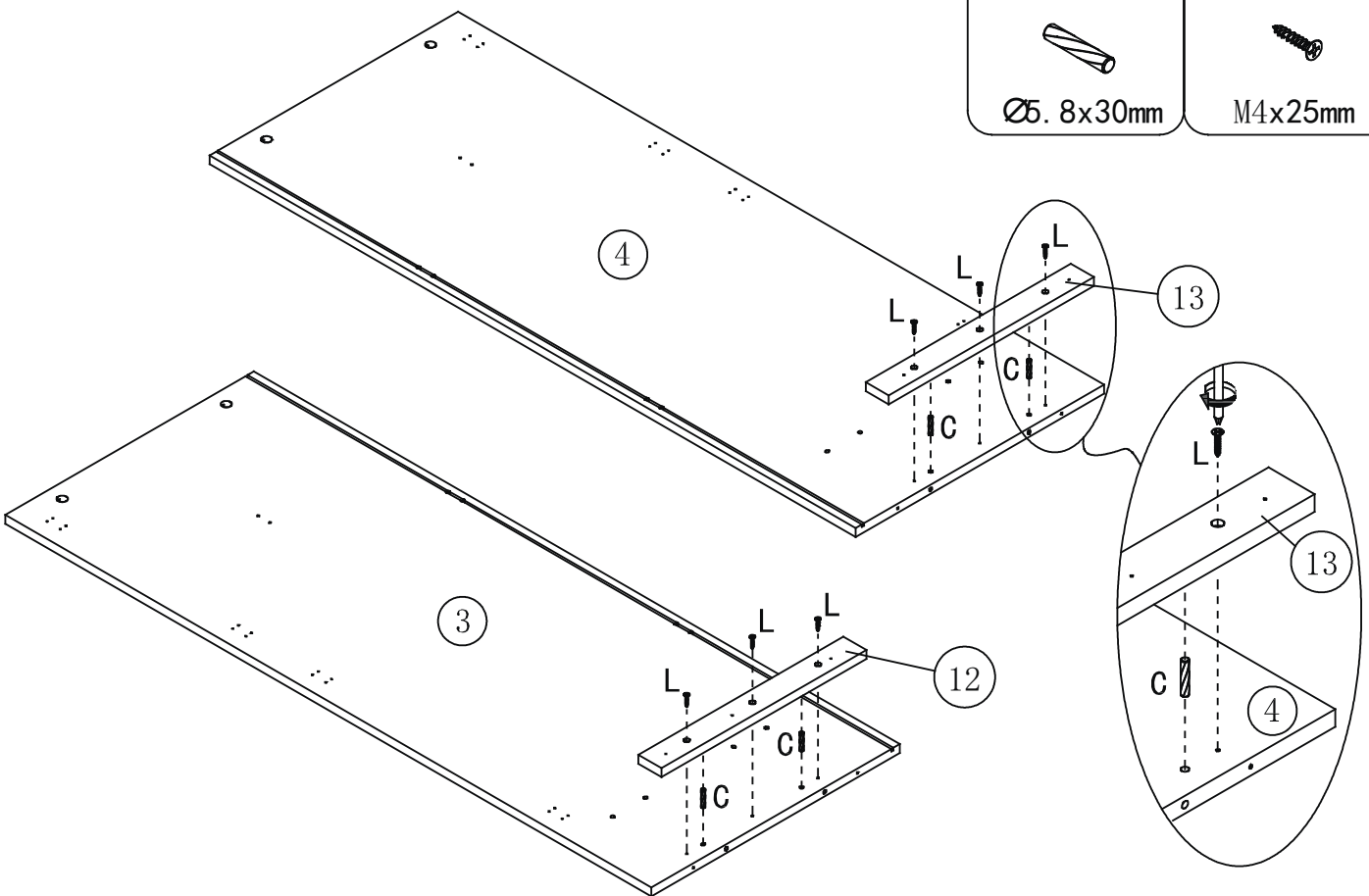

# STEP 9

F (CL) x1 400mm	F (CR) x1 400mm	G x6 M3. 5x12mm
--------------------	--------------------	--------------------

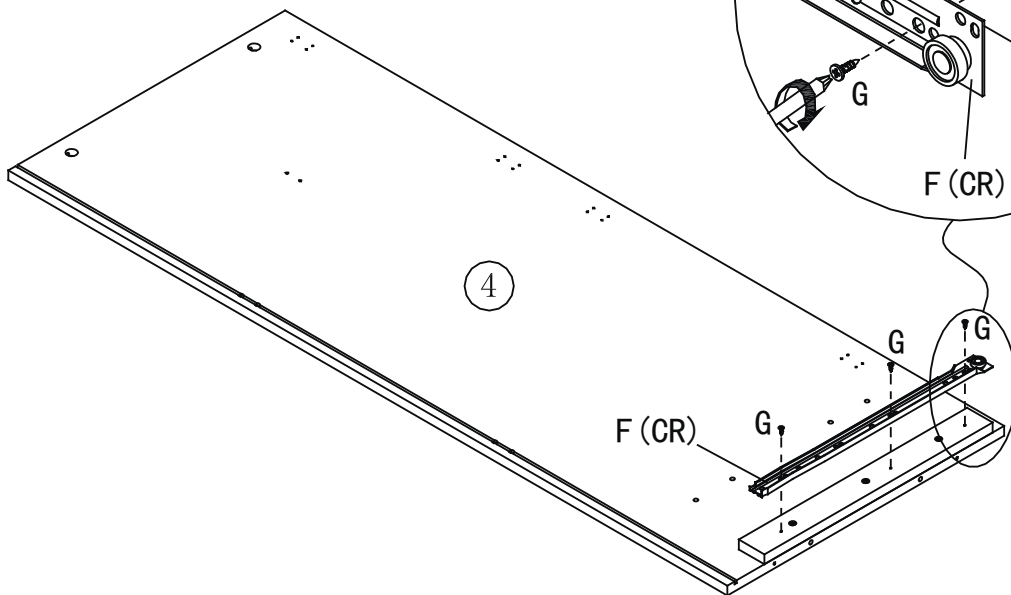
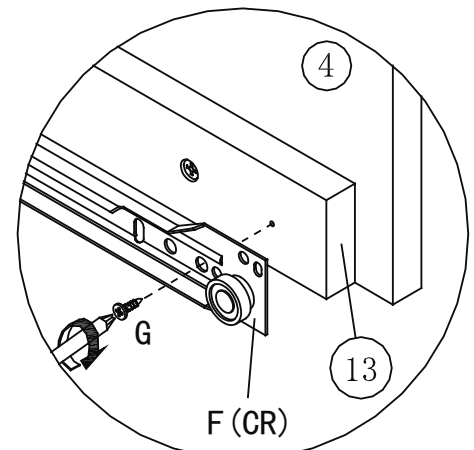
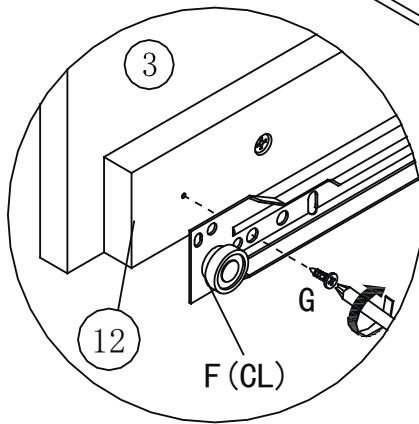
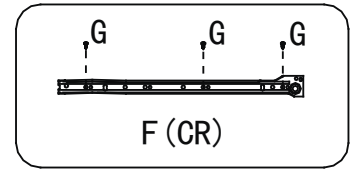
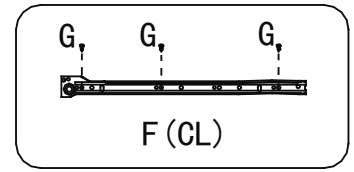
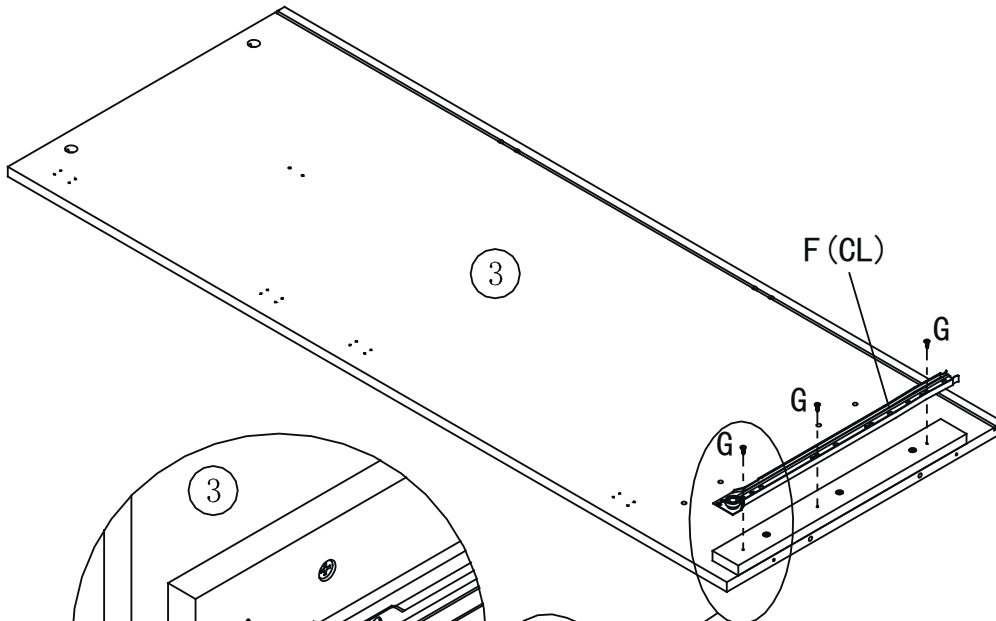

STEP 10

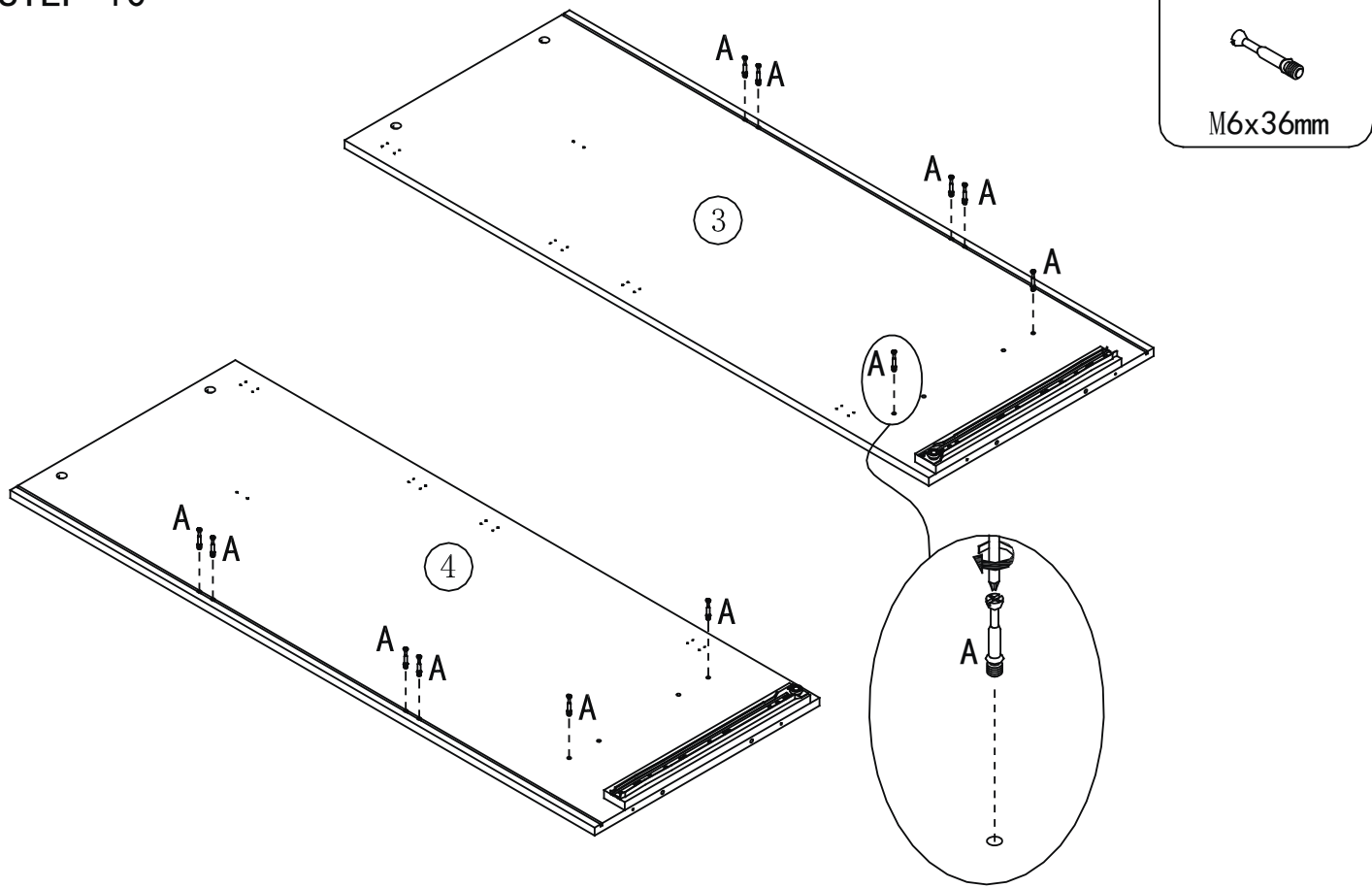

STEP 11

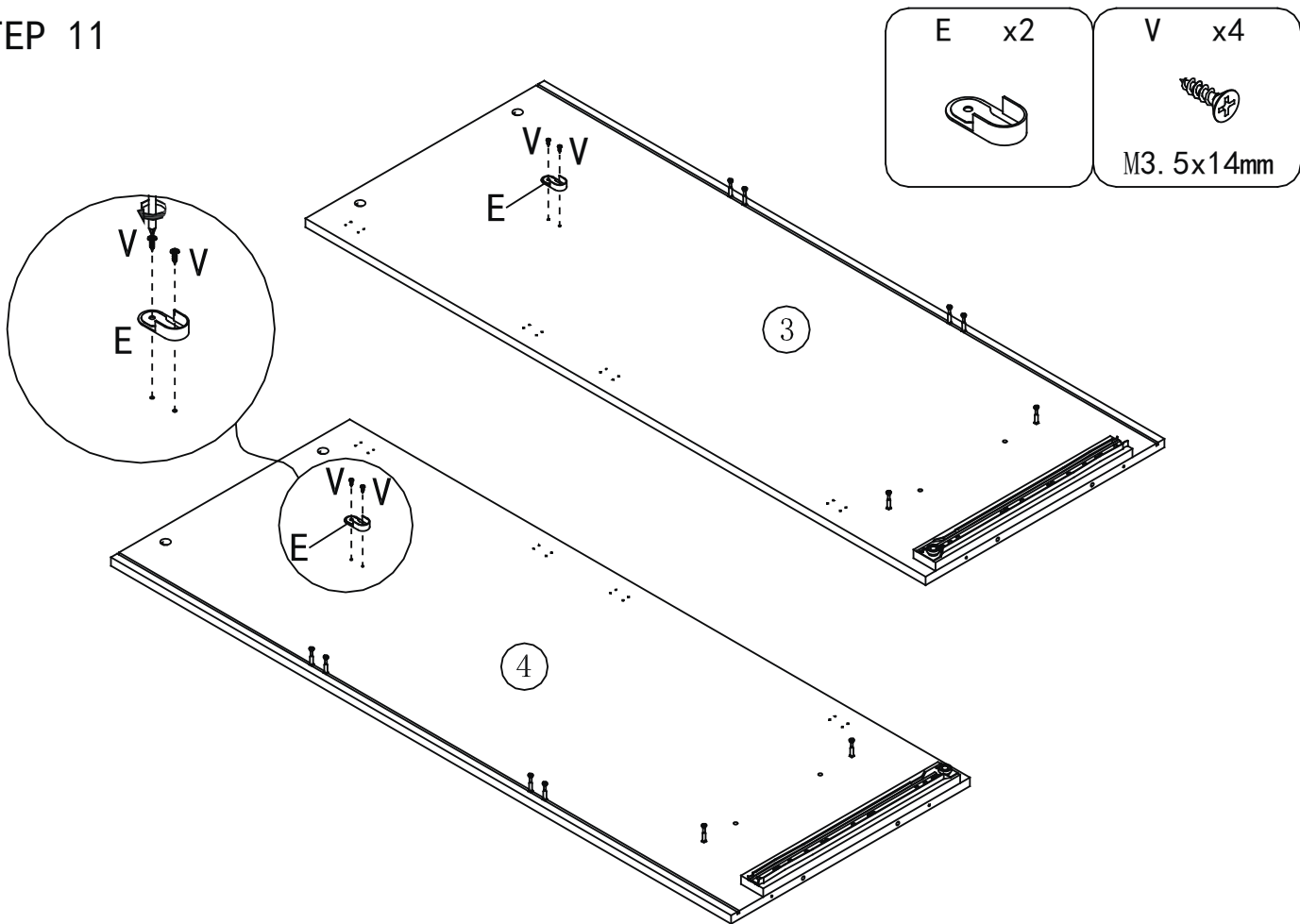

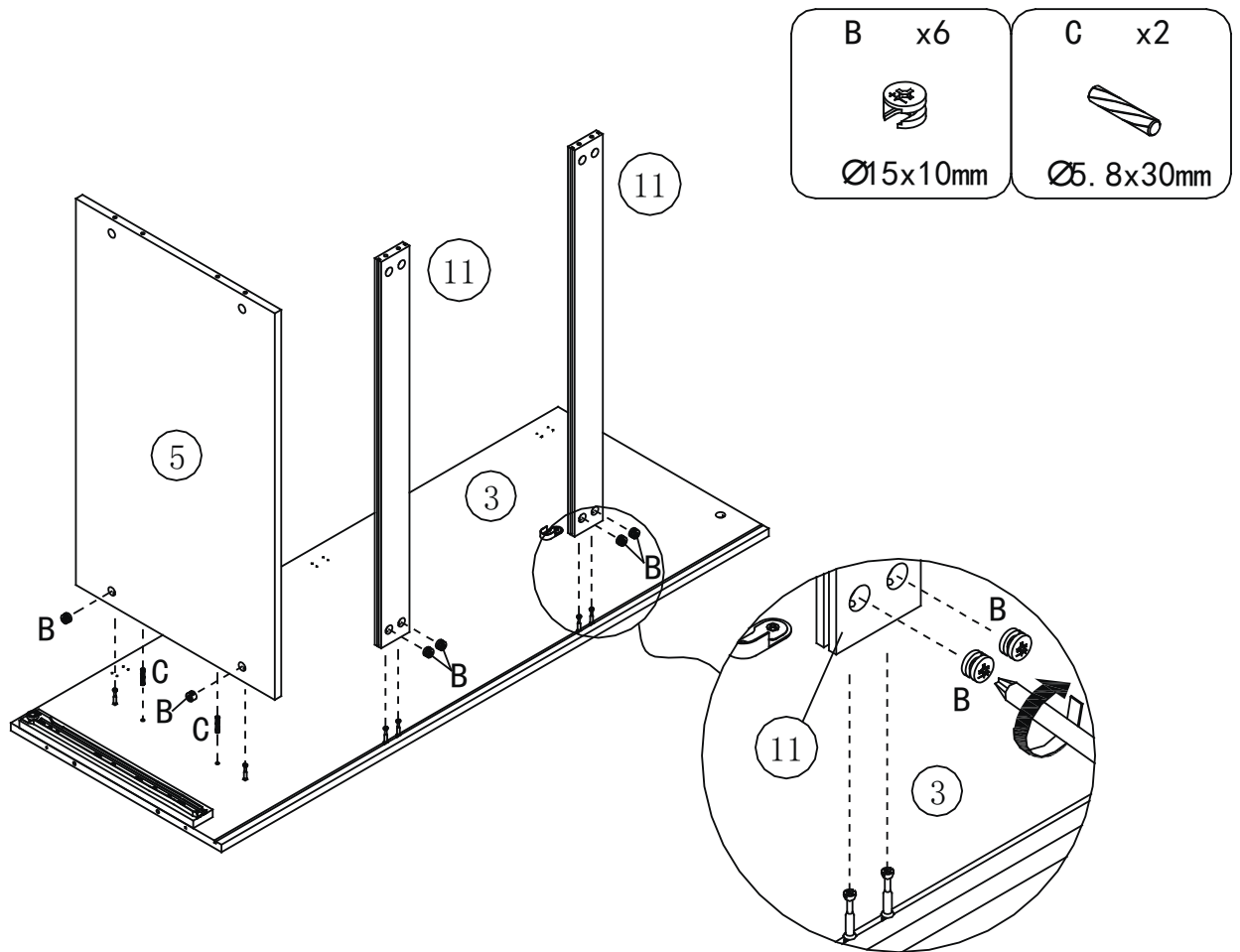

# STEP 12

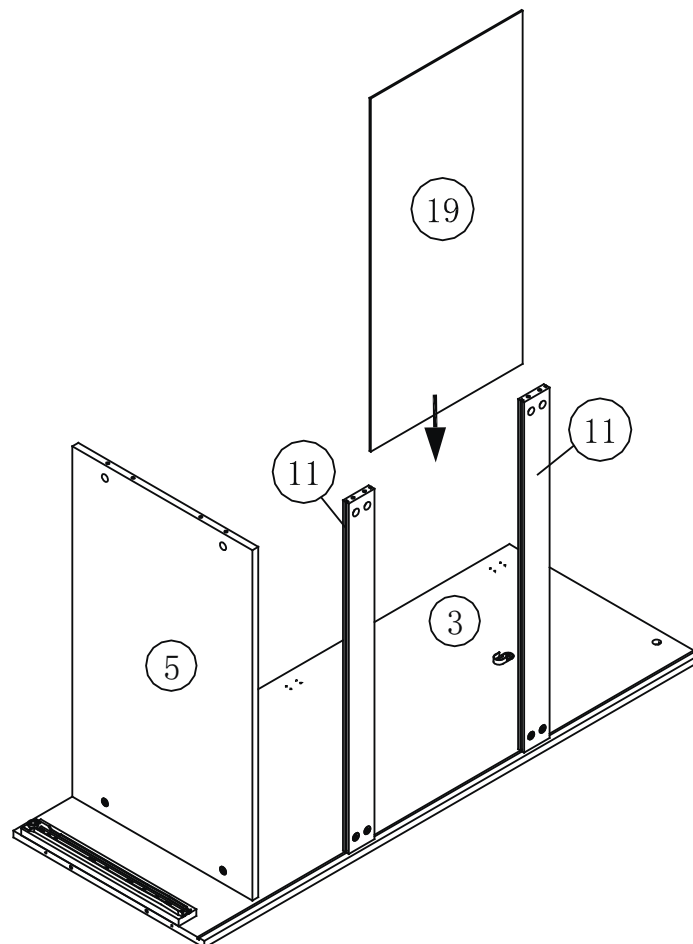

# STEP 13



# STEP 14

<b>B</b> x6	<b>C</b> x2
	
Ø15x10mm	Ø5.8x30mm

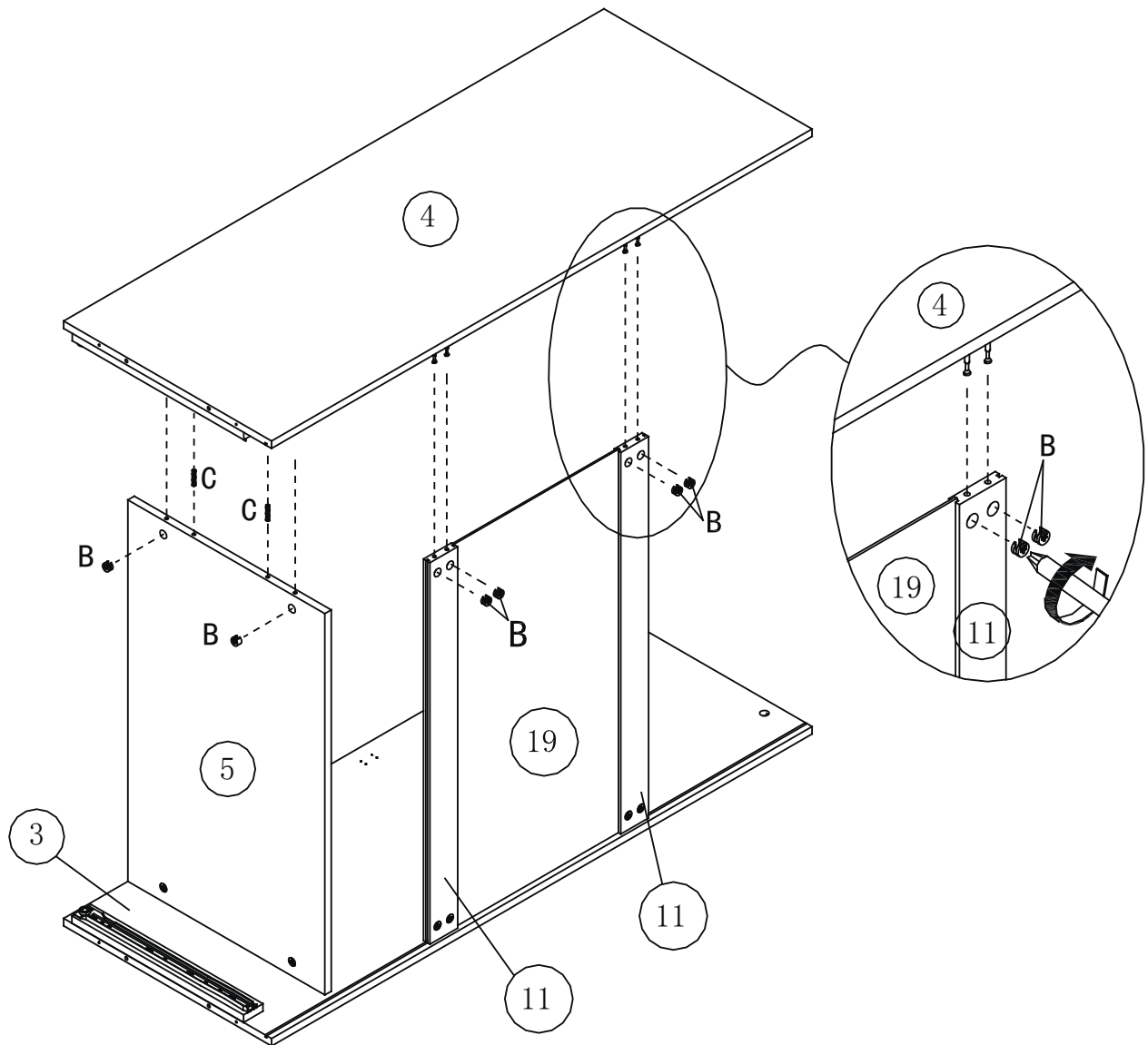

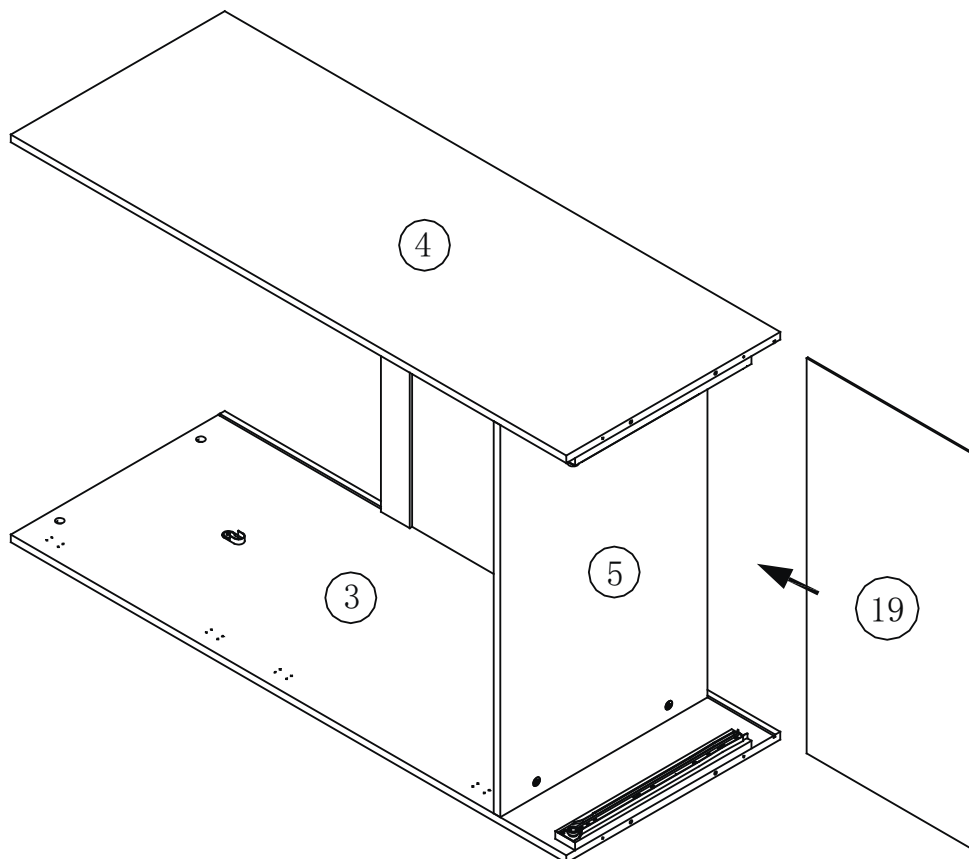

# STEP 15

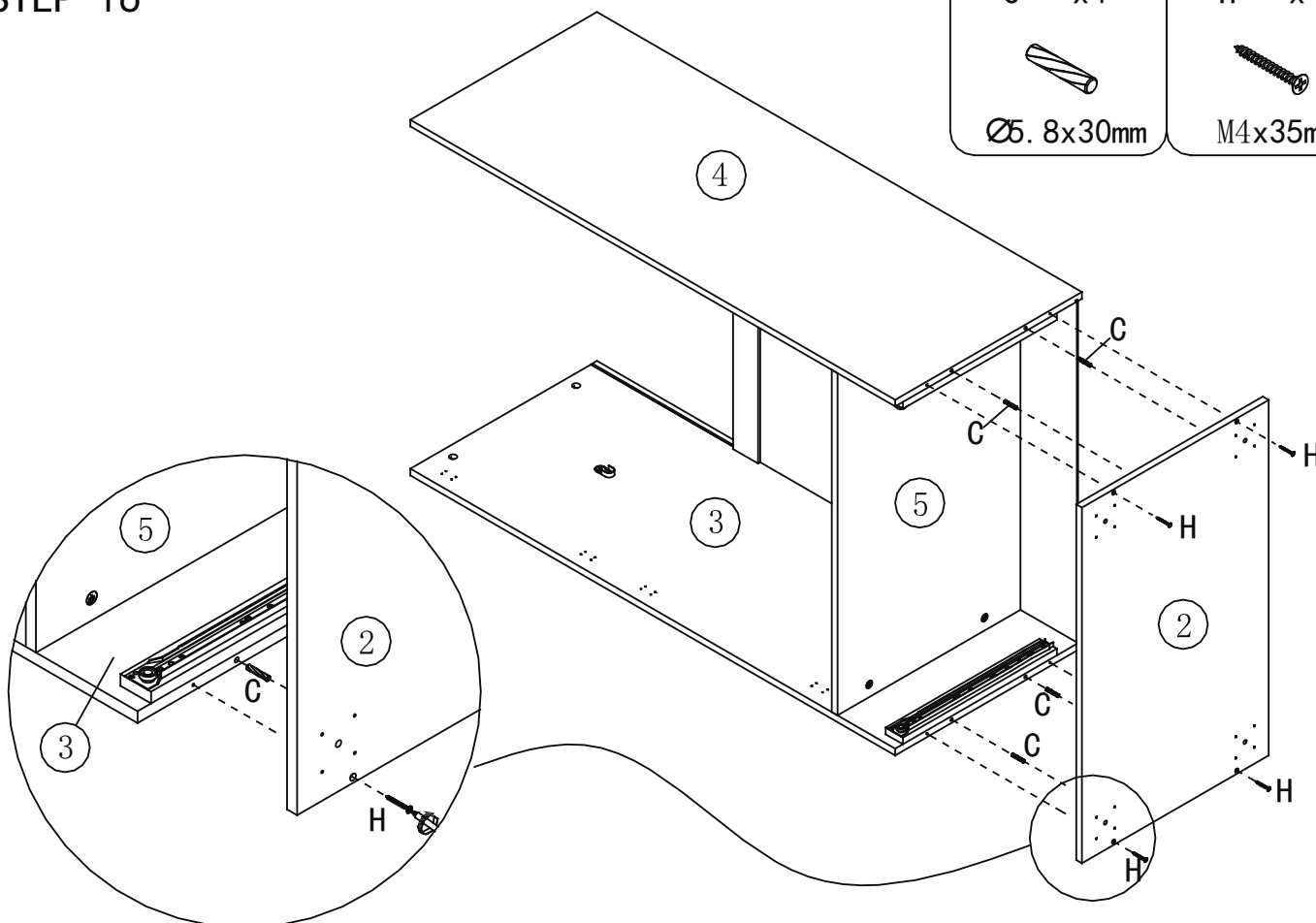
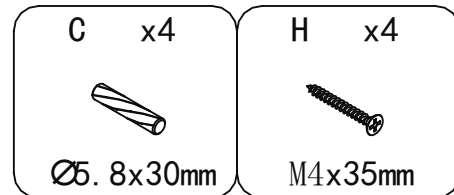

# STEP 16

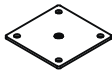

# STEP 17

I x4	J x16
	
	M4x14mm

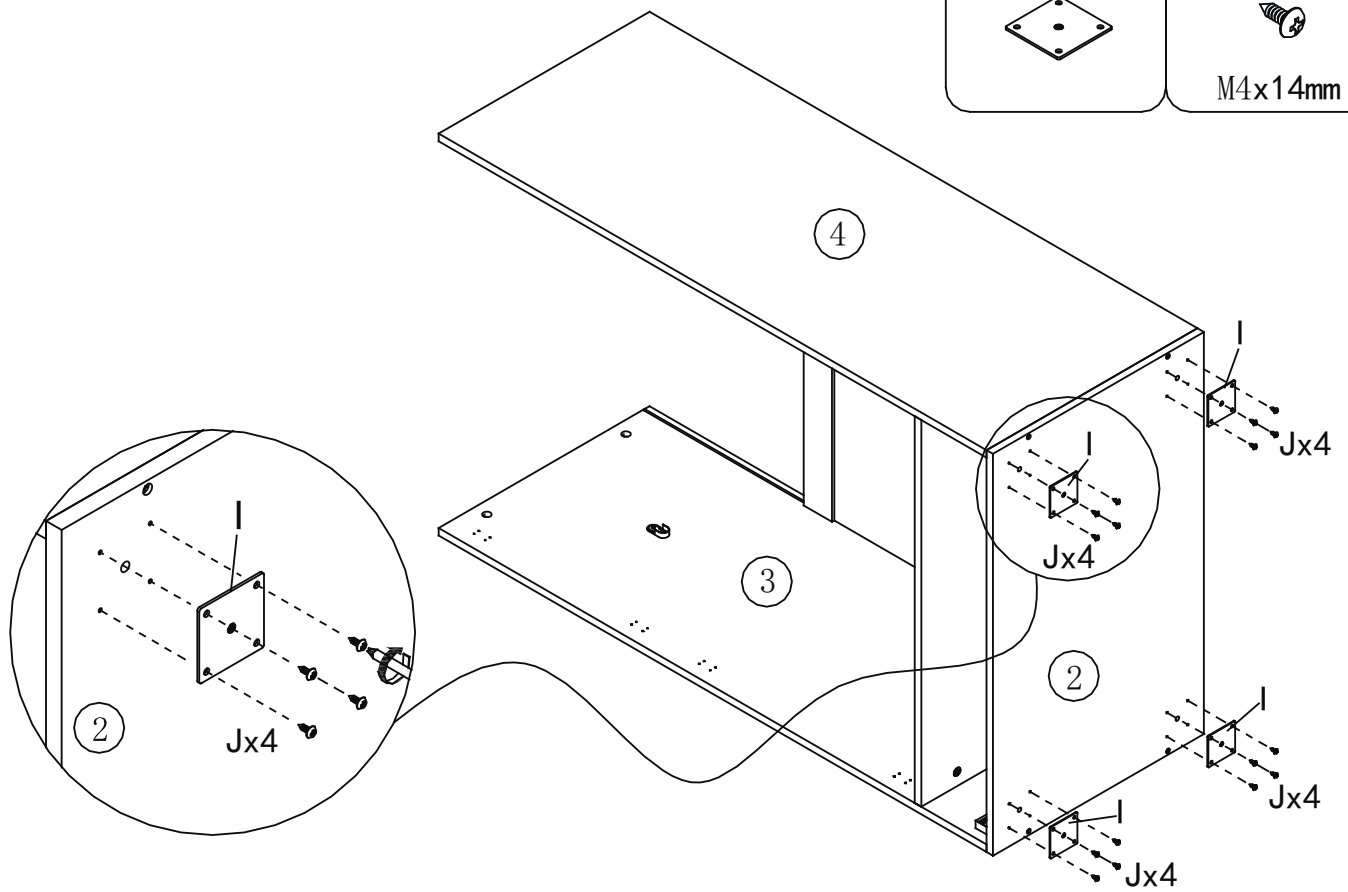

# STEP 18

K x4

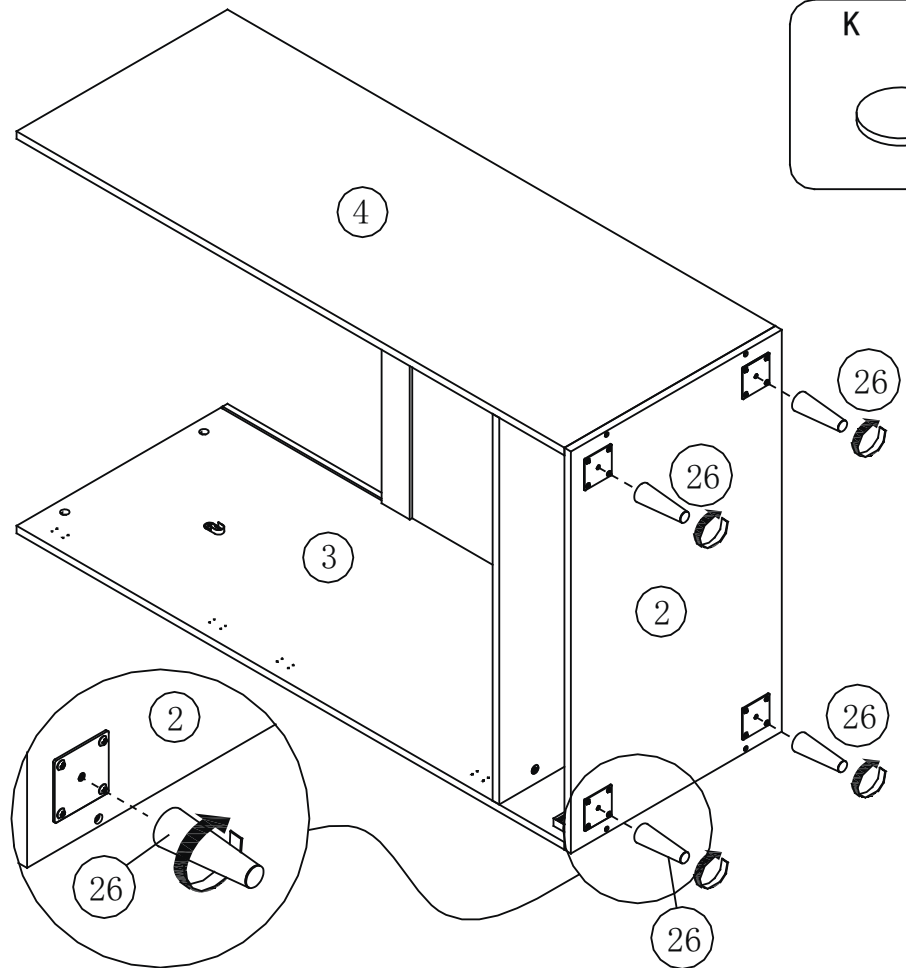
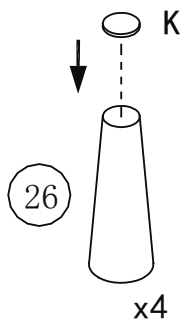
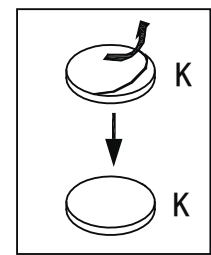

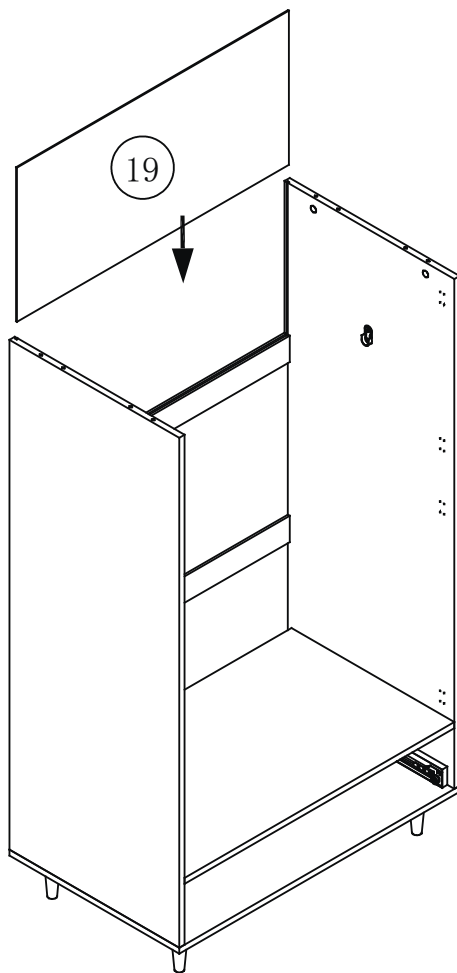

# STEP 19



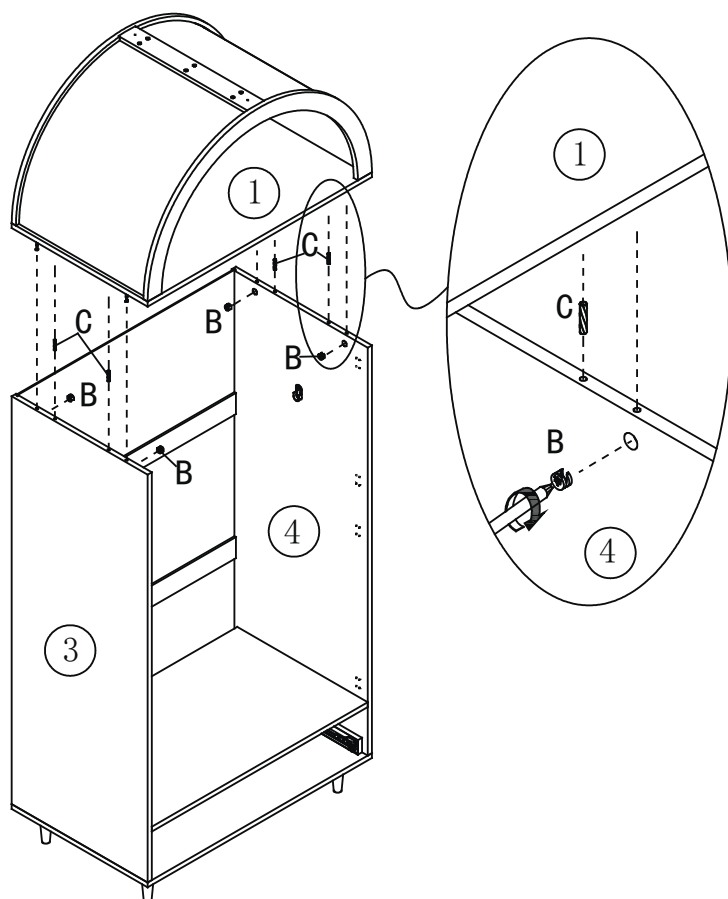

# STEP 20



<b>B</b> x4	<b>C</b> x4
	
Ø15x10mm	Ø5.8x30mm

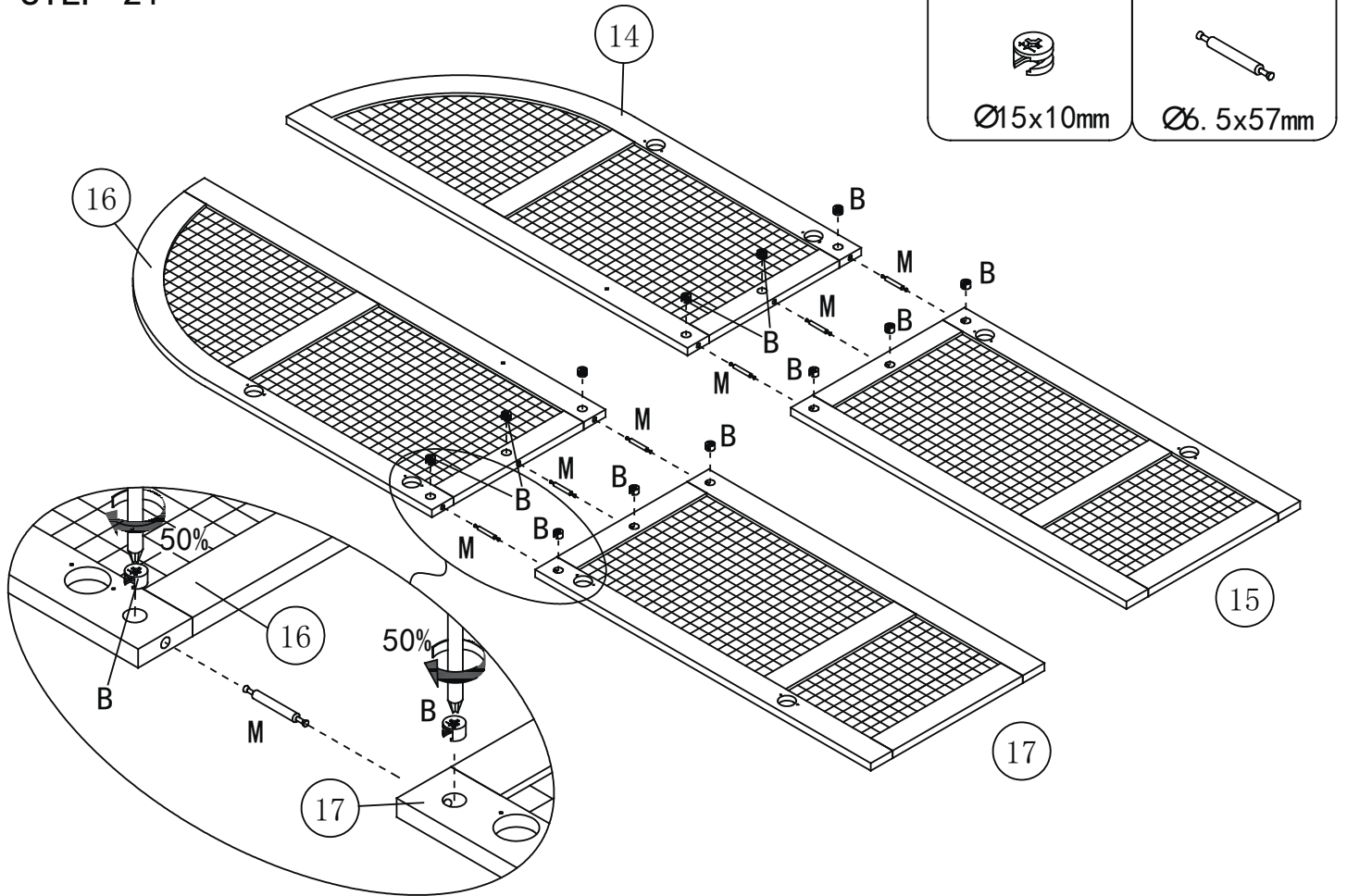



# STEP 21

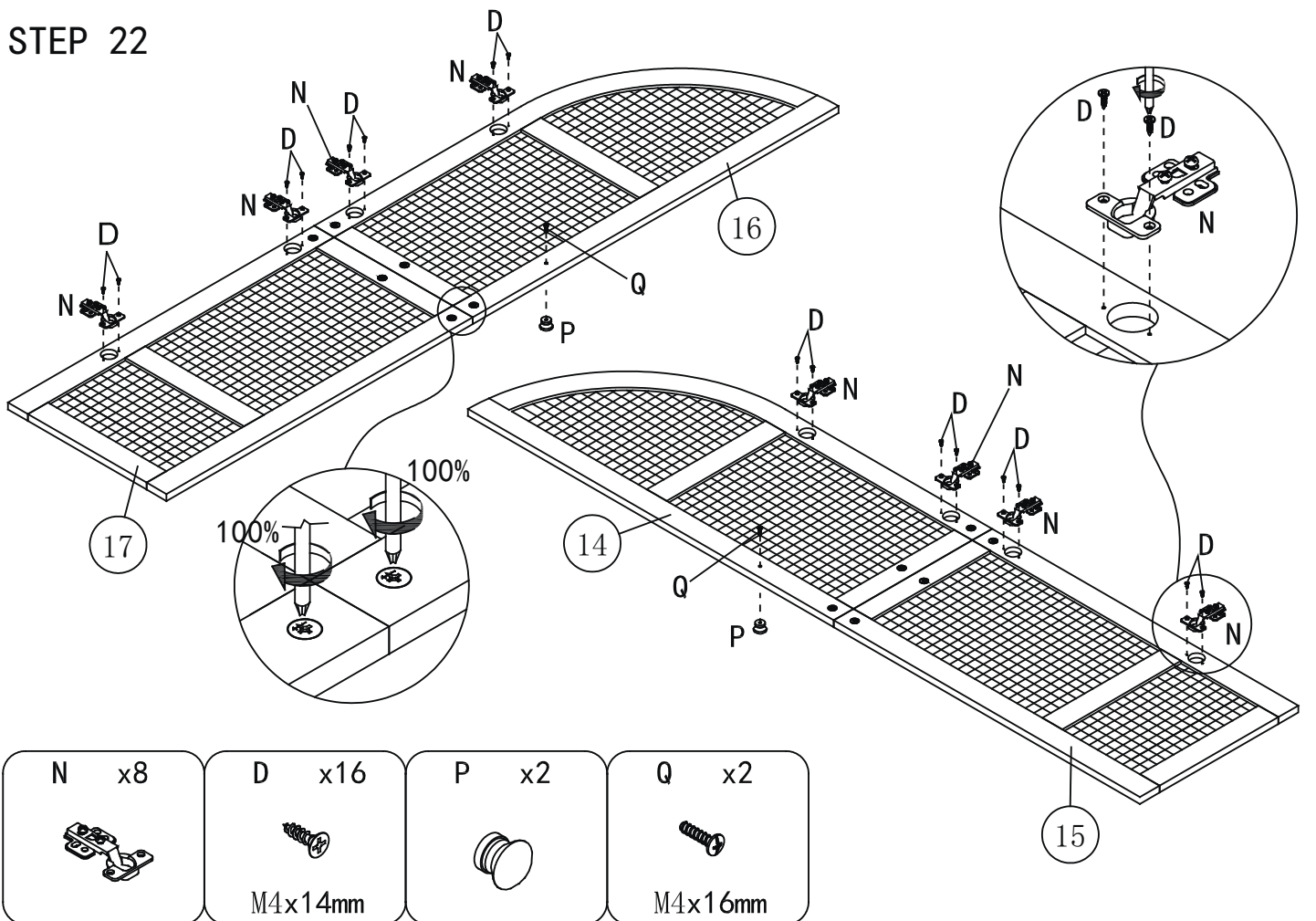

- |   |   |
|---|---|
| B x12   | M x6  |
|  |  |
| Ø15x10mm  | Ø6.5x57mm   |

# STEP 22



- |   |   |   |   |
|---|---|---|---|
| N x8  | D x16   | P x2  | Q x2  |
|  |  |  |  |
|   | M4x14mm   |   | M4x16mm   |

STEP 23

D x16



M4x14mm

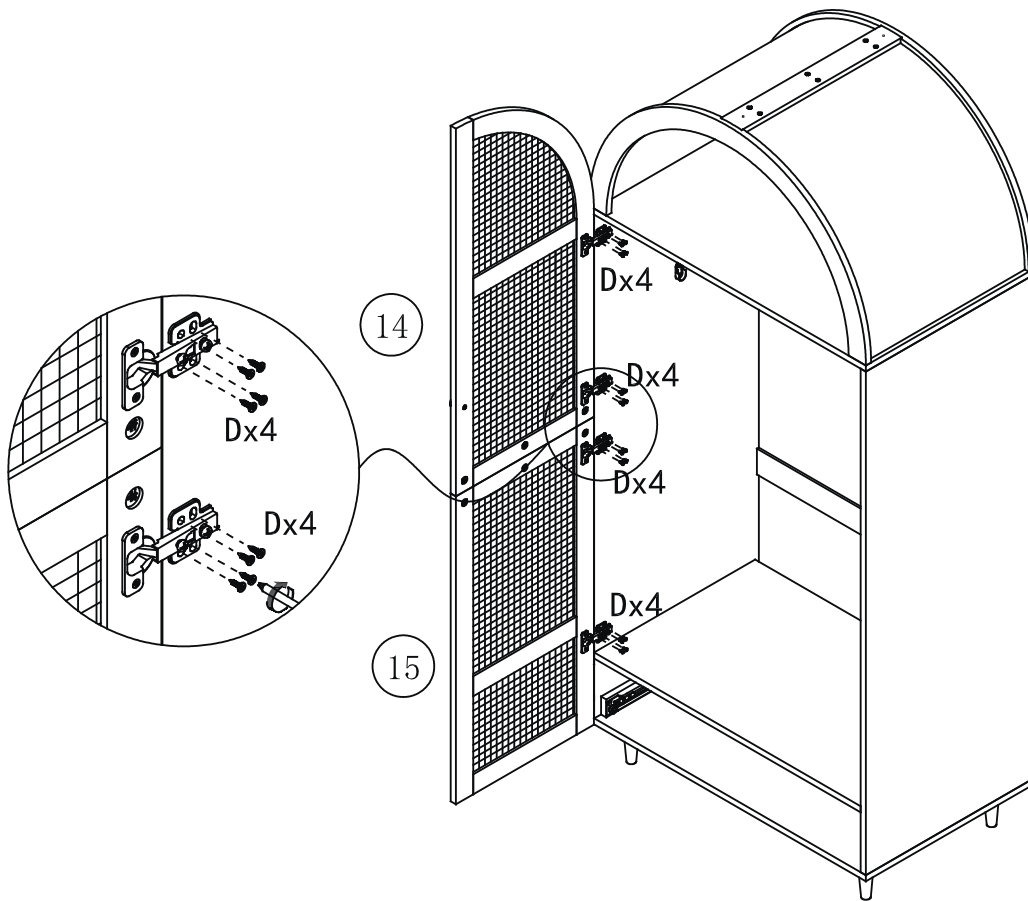

STEP 24

D x16



M4x14mm

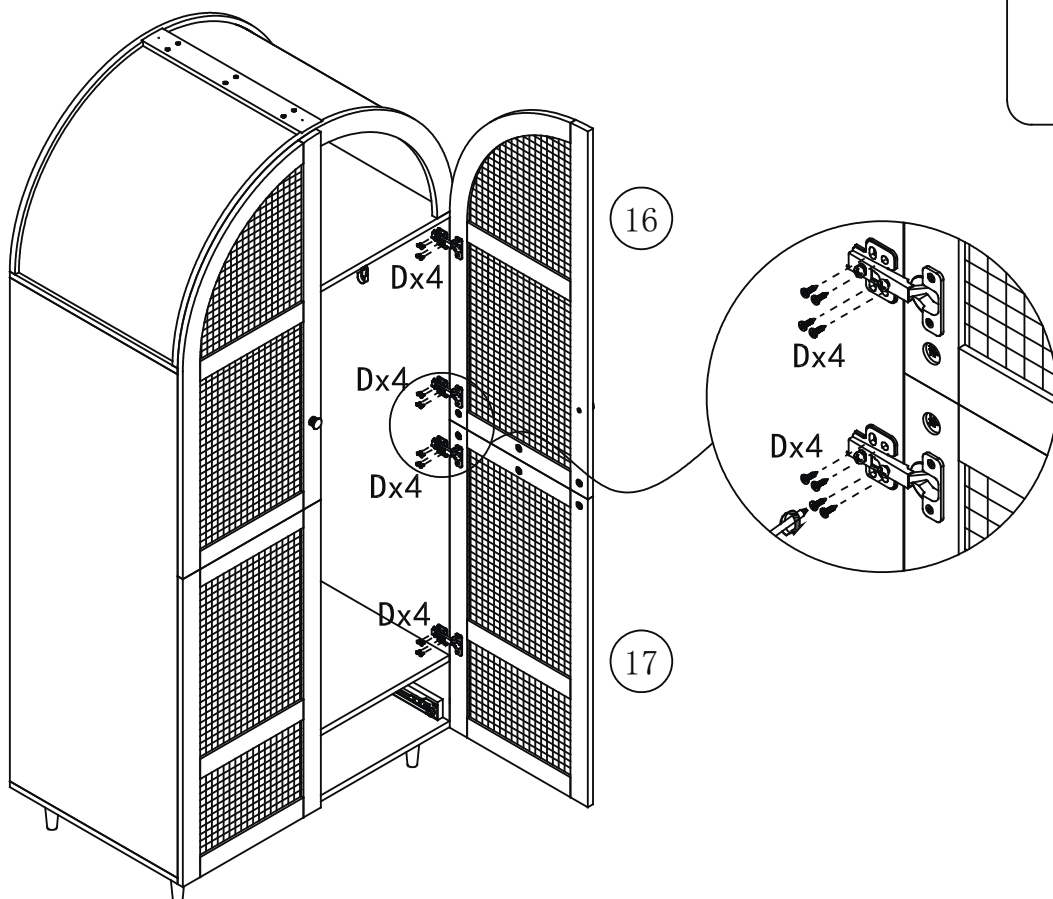

- When the hinges are installed, you can refer to the pictures to adjust crevice of the doors till it's perfect:
- Wenn die Scharniere installiert sind, können Sie sich die Bilder ansehen, um den Spalt der Türen anzupassen, bis es perfekt ist:
- Lorsque la charnière est installée, vous pouvez vous référer à l'image pour ajuster la fente de la porte jusqu'à ce qu'elle soit parfaite:

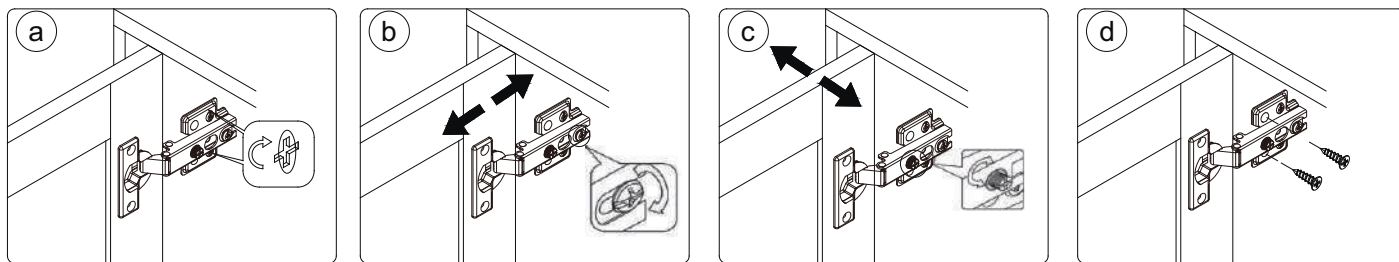

1. To adjust the doors up and down, please refer to step (a)
  2. To adjust the distance between the doors and side panels, please refer to step(b)
  3. 'To adjust the gap between two doors, please refer to step (c)
  4. After the adjustment finished, please tight the screws, refer to step(d)
1. Um die Türen nach oben und unten einzustellen, siehe Schritt (a)
  2. Um den Abstand zwischen den Türen und den Seitenwänden einzustellen, lesen Sie bitte Schritt(b)
  3. "Um den Abstand zwischen zwei Türen einzustellen, siehe Schritt c)
  4. Nachdem die Einstellung beendet ist, ziehen Sie bitte die Schrauben fest, siehe Schritt(d)
1. Pour régler les portes de haut en bas, reportez - vous à l'étape (A)
  2. Pour régler la distance entre la porte et le panneau latéral, reportez - vous à l'étape b)
  3. "Pour régler l'écart entre les deux portes, reportez - vous à l'étape (c)
  4. Une fois le réglage terminé, serrez les vis, voir étape (d)

# STEP 25

R x12



S x12



M3x16mm

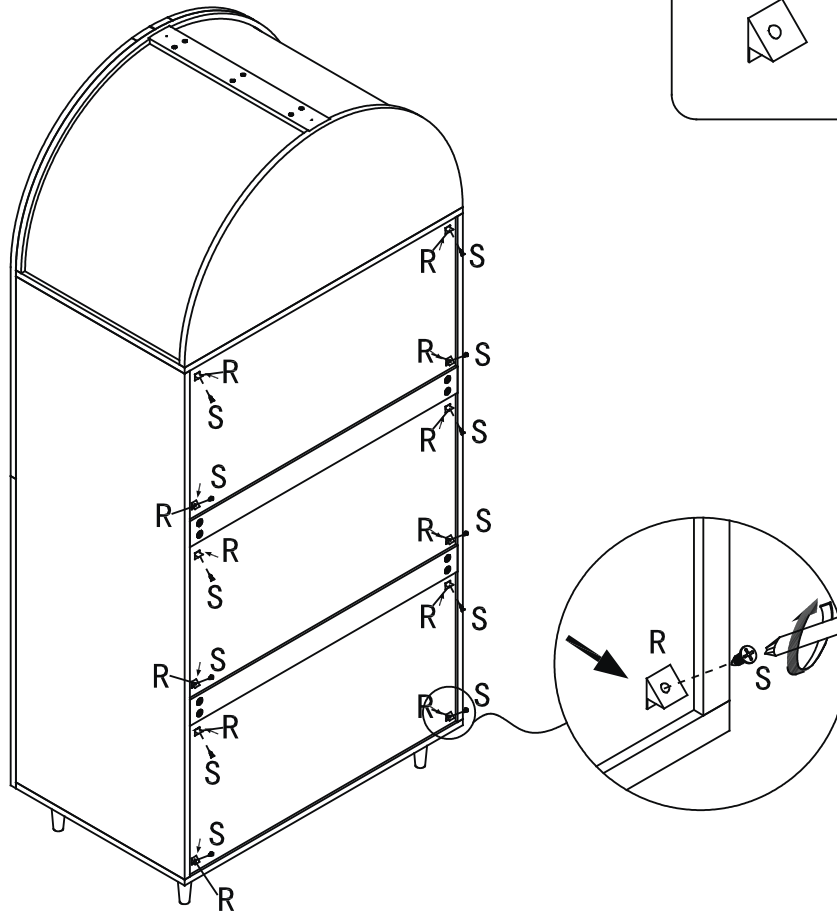

# STEP 26

J x1



M4x14mm

T x1

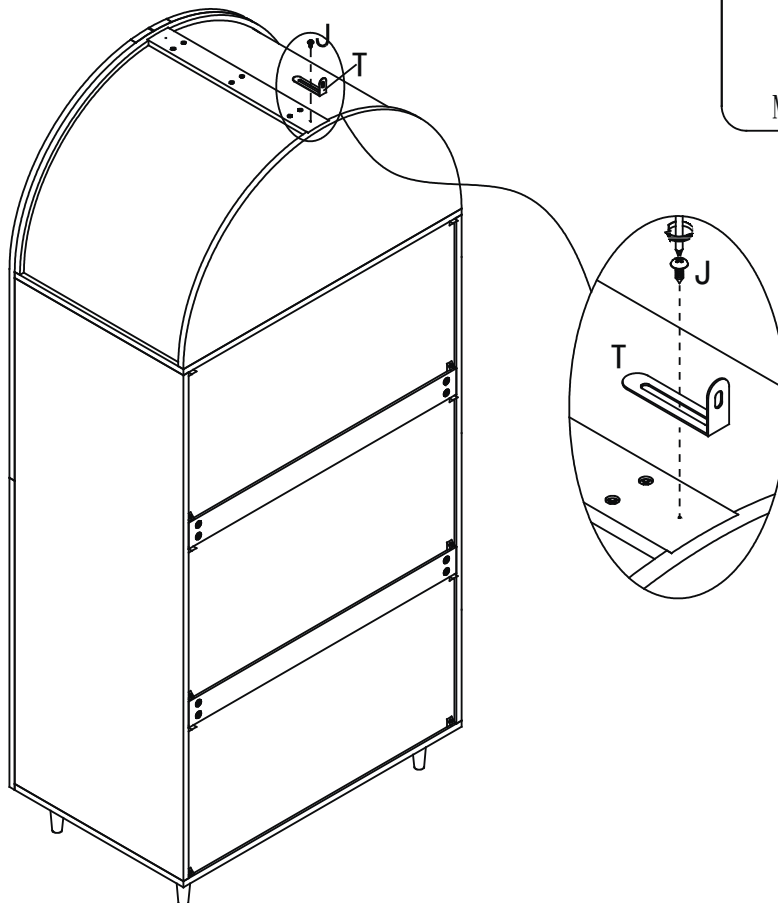
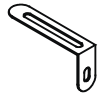

STEP 27

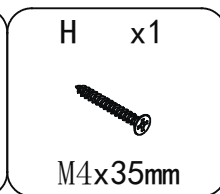
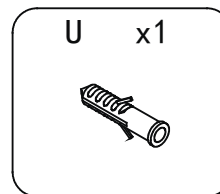
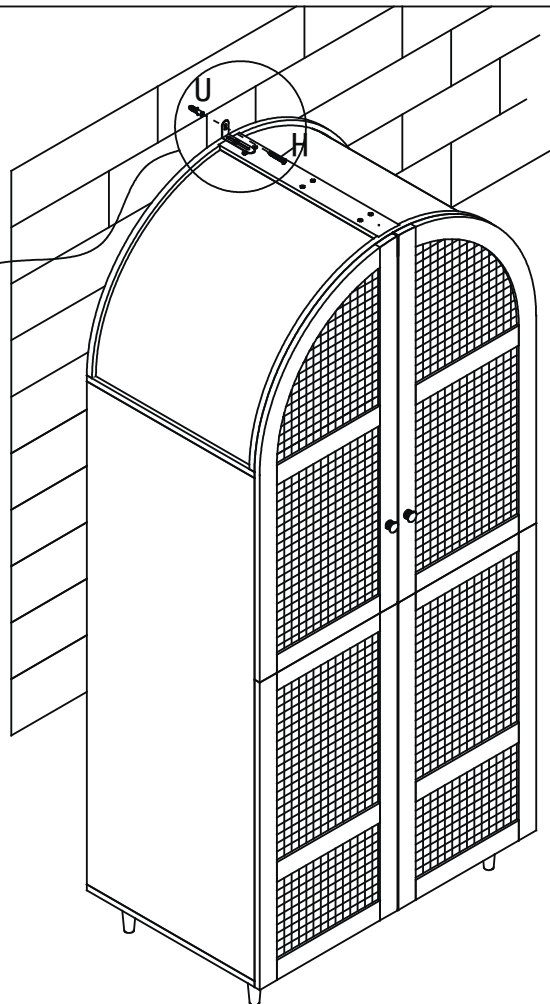
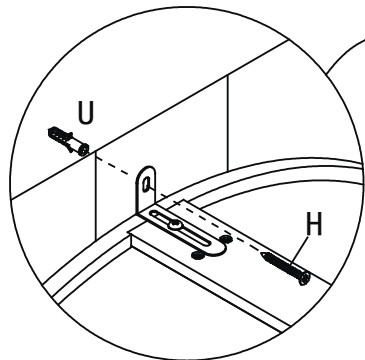

STEP 28

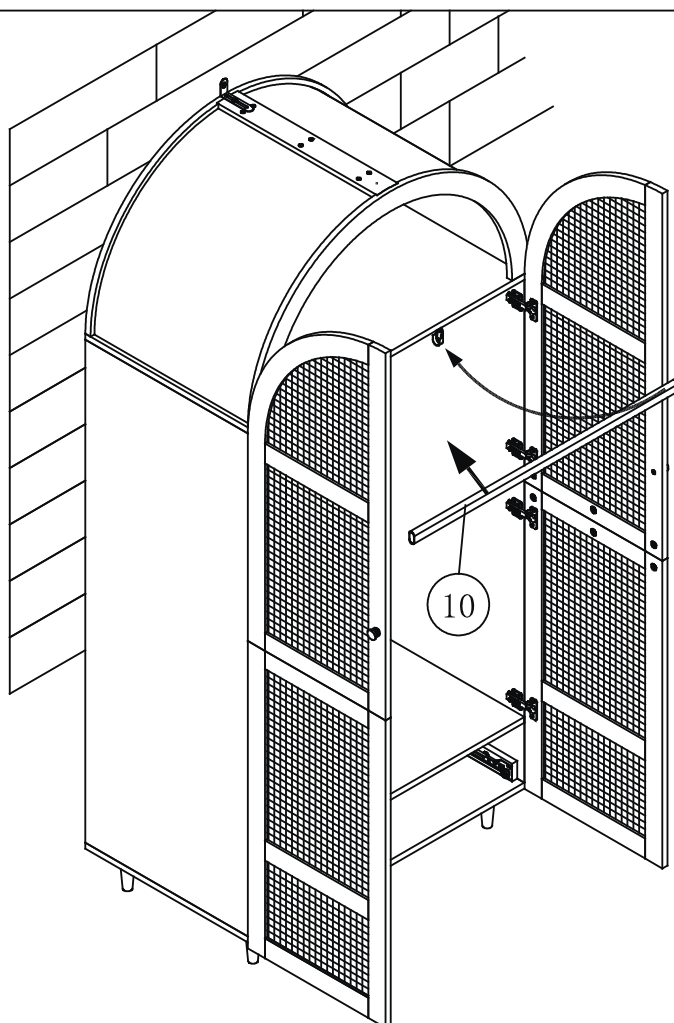

# STEP 29

H x5  
  
M4x35mm

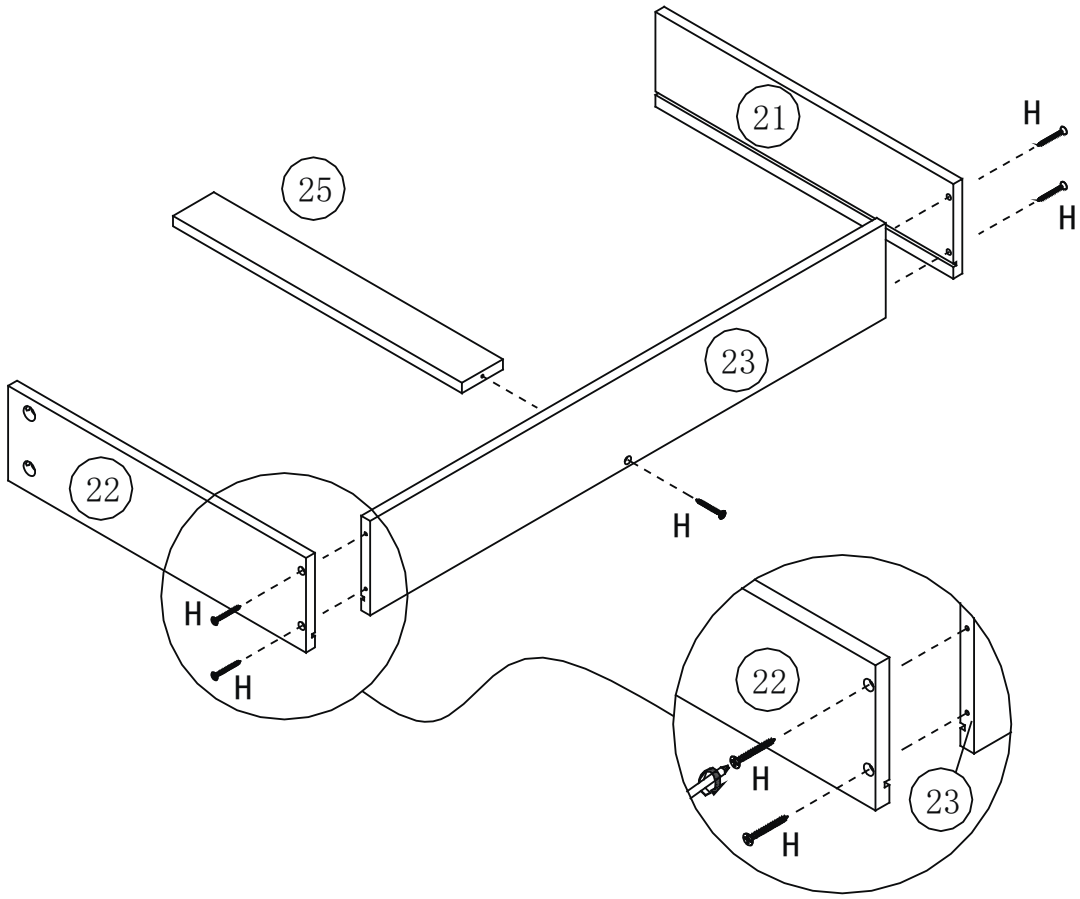

# STEP 30

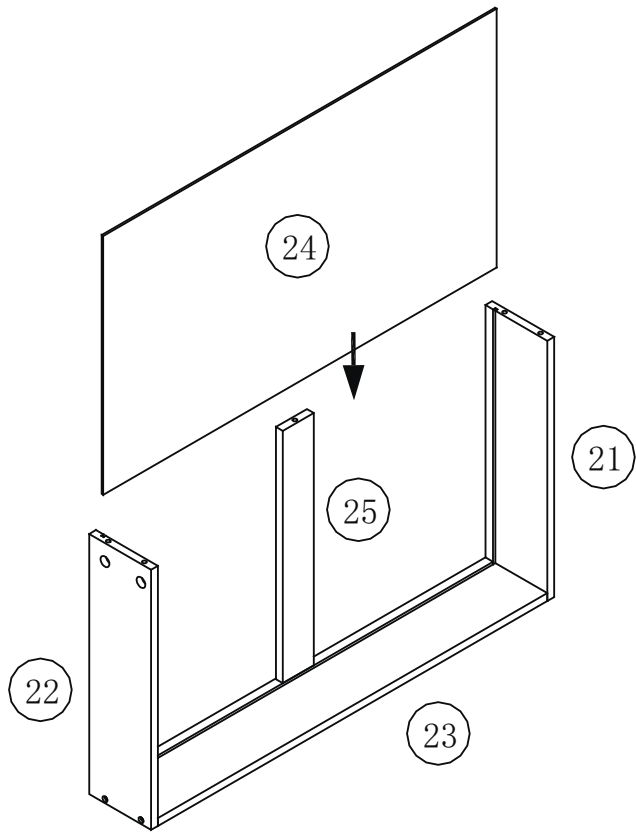

# STEP 31

A x5  
  
M6x36mm

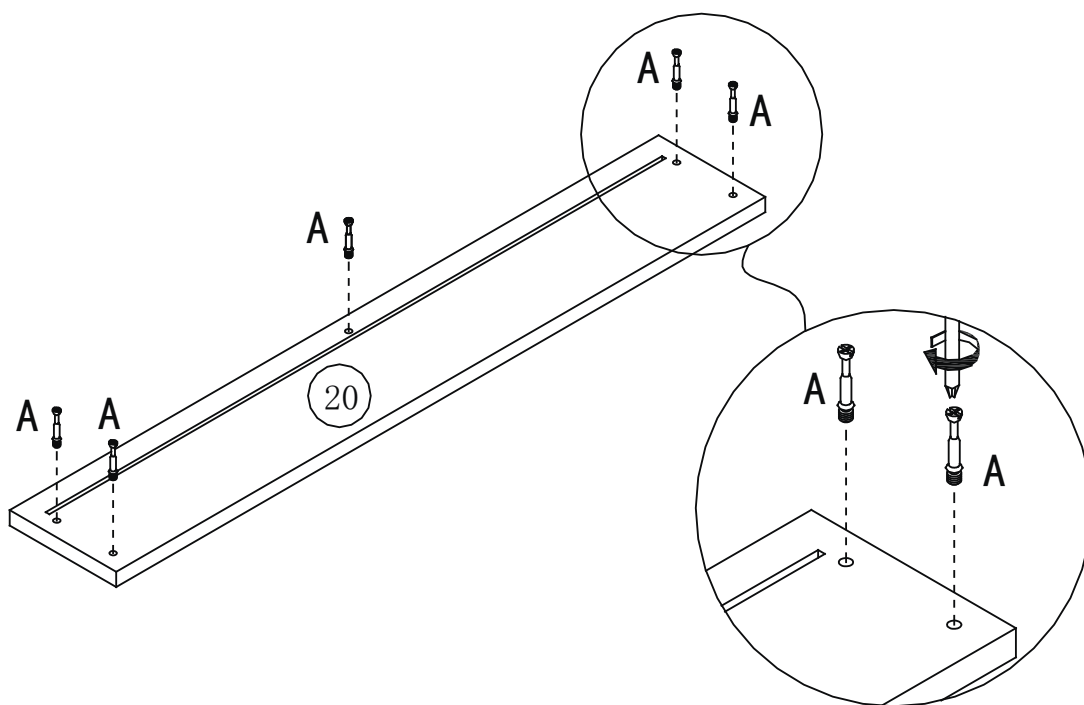

# STEP 32

B x5  
  
Ø15x10mm

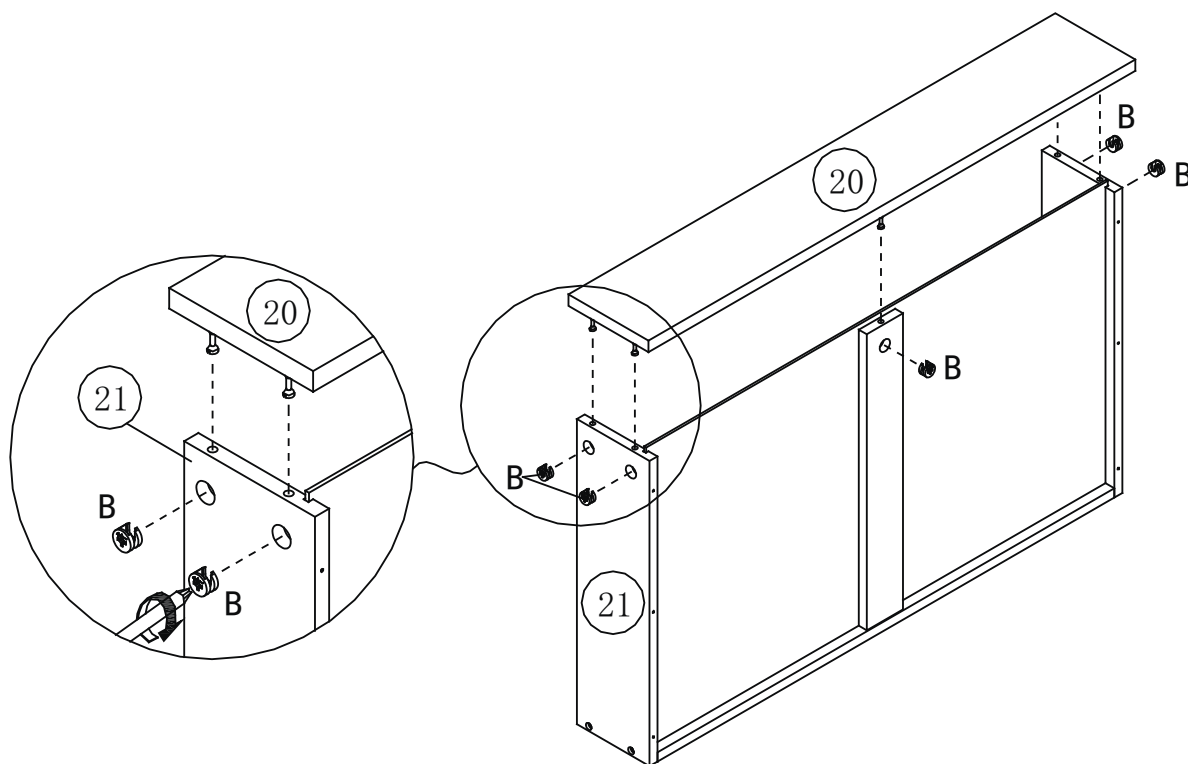

# STEP 33

F (DL) x1 400mm	F (DR) x1 400mm	G x6 M3. 5x12mm
--------------------	--------------------	--------------------

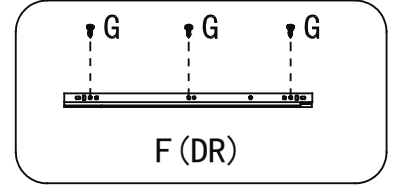
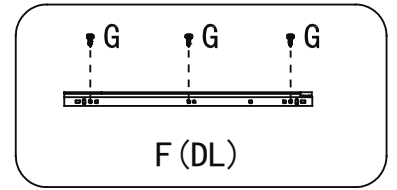
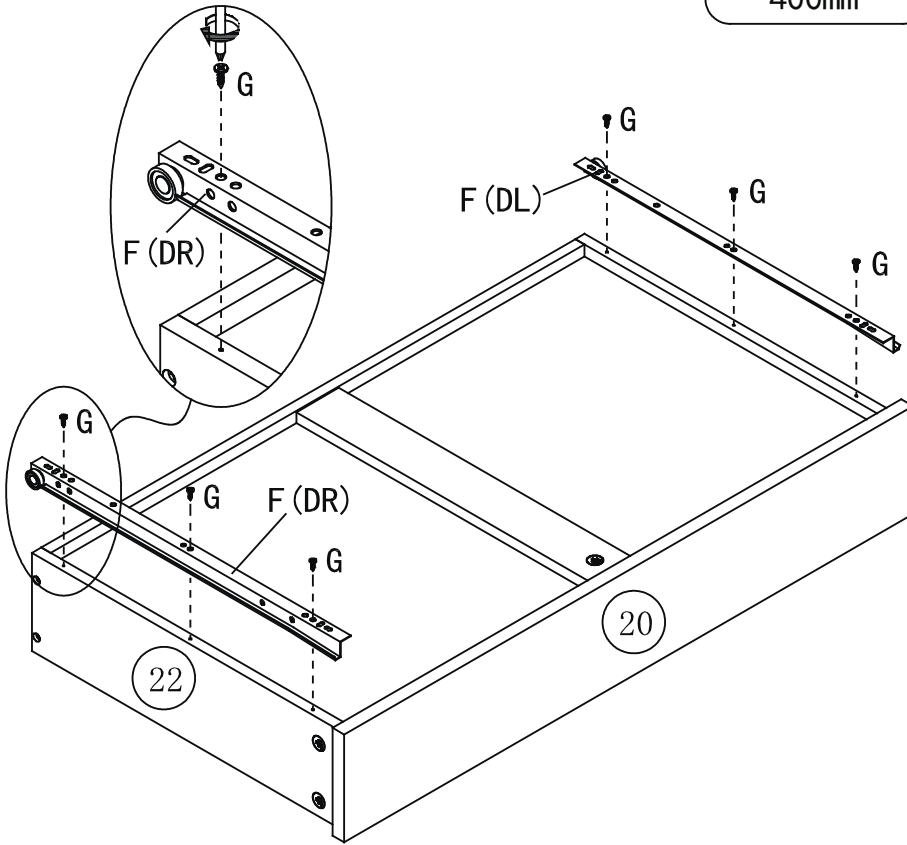

# STEP 34

