

Installationsanleitung Installation Instruction Instructions d'installation

N623PI I I I €1/PÎ GHÚI I I I €2

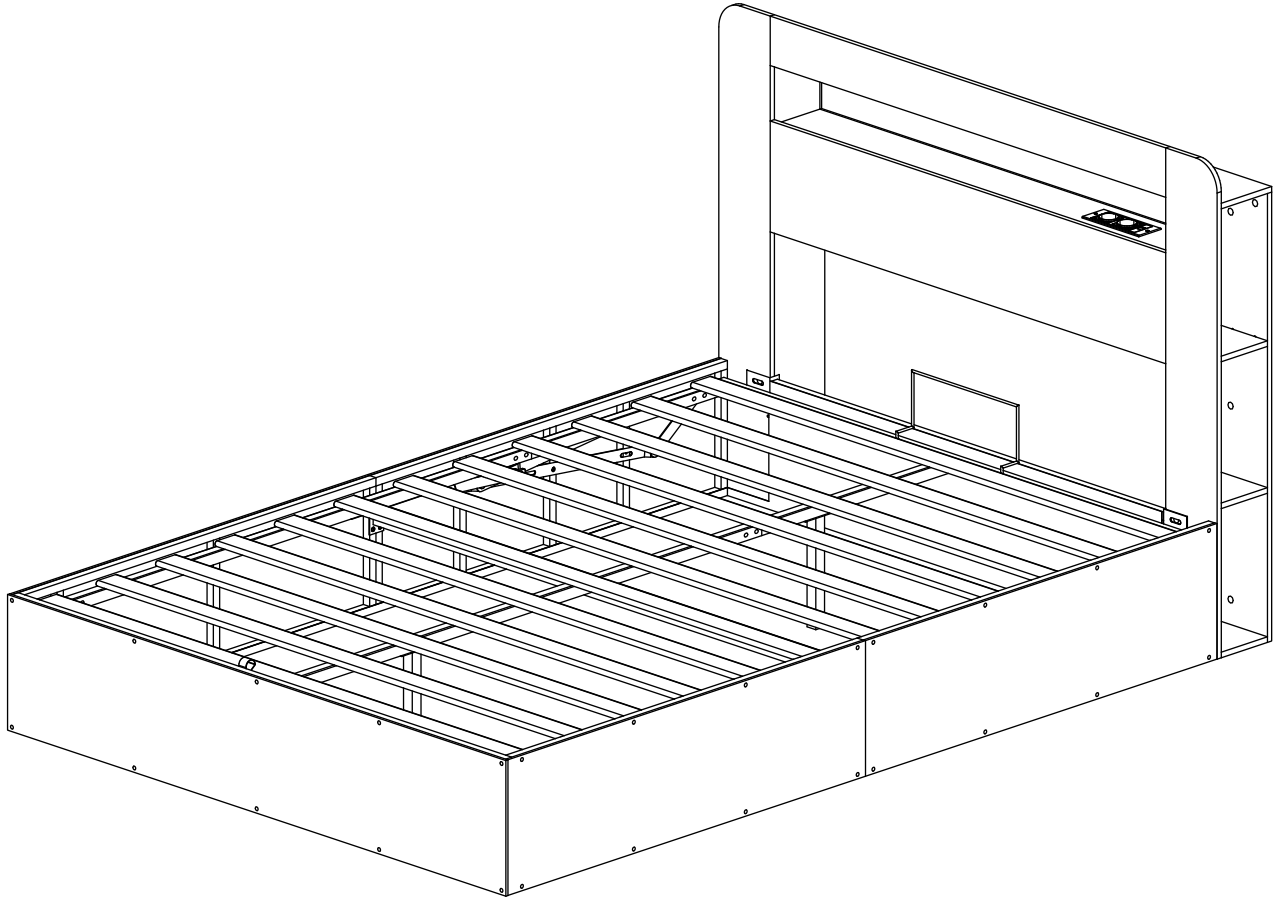

V3.0

DE: Unser Produkt wird Ihnen in 2 Paketen geliefert. Die Lieferzeiten dieser 2 Pakete können abweichen, bitte haben Sie etwas Geduld und vielen Dank für Ihr Verständnis.

UK: Our product will be delivered to you in 2 packages. The delivery times of these 2 packages may differ, please be patient and thank you for your understanding.

FR: Notre produit vous sera livré en 2 colis. Les délais de livraison de ces 2 colis peuvent différer, soyez patient et merci pour votre compréhension.

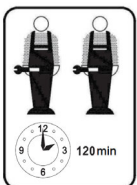

CE



FR
Cet appareil,
ses cordons,
et batterie
se recyclent

À DÉPOSER
EN MAGASIN

À DÉPOSER
EN DÉCHÈTERIE

OU

Points de collecte sur www.quefairedemesdechets.fr
Privilégiez la réparation ou le don de votre appareil !

DE:Vor dem Einbau die Schrauben in die Löcher stecken und festziehen, aber nicht bis 100%, 70% bis 80% anziehen reicht aus. Schließlich, nachdem alle Schrauben installiert sind, ziehen Sie alle Schrauben auf 100%.Wenn Sie auf diese Probleme stoßen, wie z. B. Fehlausrichtung der Löcher oder Unfähigkeit, bestimmte Teile zu installieren, überprüfen Sie bitte, ob die Schrauben korrekt verwendet werden und passen Sie die Dichtigkeit der Schrauben an.

UK:Before installation, insert the screws into the holes and tighten them, but do not tighten them to 100%, 70% to 80% is sufficient. Finally, after all screws are installed, tighten all screws to 100%.If you encounter these issues, such as if the holes cannot be aligned or some parts cannot be installed, please check if the screws are used correctly and adjust the tightness of the screws.

FR:Insérer la vis dans le trou avant la fin de l'assemblage, serrer la vis, mais ne pas serrer à 100%, 70% ~ 80% est correct. Enfin, une fois que toutes les vis sont bien serrées, toutes les vis sont serrées à 100%.Si vous rencontrez ces problèmes, par exemple si les trous ne sont pas alignés ou si certaines pièces ne peuvent pas être montées, vérifiez que les vis sont utilisées correctement et Ajustez leur serrage.

English

IMPORTANT FOR GAS LIFT BEDS&MAINTAINCE

- Please place the mattress on top of the bed frame.
- Please do not pull on the strap handles.
- Please press heavily to release the compressed gas.
- Periodically check all screw & fixings to ensure they are secure.
- When moving your product, carefully lift into place.
- Wipe clean with a slightly damp cloth- please do not use abrasive chemicals or bleach.
- Do NOT allow children to operate the lift mechanism.
- Do NOT allow children near the lift base when operating the mechanism.
- Do NOT stand inside the bed or the internal storage base.
- Do NOT overload the internal storage base.
- DO NOT jump on the product or any of its parts.

Deutsch

WICHTIG FÜR GASLIFT-BETTEN&WARTUNG

- Bitte legen Sie die Matratze oben auf den Bettrahmen.
- Bitte ziehen Sie nicht an den Gurtgriffen.
- Bitte drücken Sie kräftig, um das komprimierte Gas freizusetzen.
- Überprüfen Sie regelmäßig alle Schrauben und Befestigungen, um sicherzustellen, dass sie sicher sind.
- Wenn Sie Ihr Produkt bewegen, heben Sie es vorsichtig an seinen Platz.
- Mit einem leicht feuchten Tuch abwischen - bitte keine scheuernden Chemikalien oder Bleichmittel verwenden.
- Erlauben Sie Kindern NICHT, den Hebemechanismus zu bedienen.
- Lassen Sie Kinder NICHT in die Nähe des Liftsockels, wenn Sie den Mechanismus bedienen.
- Stellen Sie sich NICHT in das Bett oder in die Innenablage.
- Überlasten Sie den internen Liftsockel NICHT.
- Springen Sie NICHT auf das Produkt oder eines seiner Teile.

Français

IMPORTANT POUR LES LITS À RELEVAGE DE GAZ&MAINTENANCE

- Veuillez placer le matelas sur le dessus du cadre de lit.
- Ne tirez pas sur les poignées de la sangle.
- Appuyez fortement pour libérer le gaz comprimé.
- Vérifiez régulièrement que toutes les vis et fixations sont bien en place.
- Lorsque vous déplacez votre produit, soulevez-le avec précaution pour le mettre en place.
- Nettoyez avec un chiffon légèrement humide - n'utilisez pas de produits chimiques abrasifs ou d'eau de Javel.
- Ne laissez pas les enfants utiliser le mécanisme de levage.
- Ne laissez pas les enfants s'approcher de la base de levage lorsqu'ils actionnent le mécanisme.
- Ne vous tenez PAS à l'intérieur du lit ou de la base de stockage interne.
- Ne surchargez pas la base de stockage interne.
- Ne pas sauter sur le produit ou l'une de ses parties.

Italiano

IMPORTANTE PER I LETTI CON SOLLEVAMENTO A GAS E LA MANUTENZIONE

- Posizionare il materasso sopra la struttura del letto.
- Non tirare le maniglie della cinghia.
- Premere con forza per rilasciare il gas compresso.
- Controllare periodicamente tutte le viti e i fissaggi per assicurarsi che siano saldi.
- Quando si sposta il prodotto, sollevarlo con cautela.
- Pulire con un panno leggermente umido, senza usare prodotti chimici abrasivi o candeggina.
- **NON** permettere ai bambini di azionare il meccanismo di sollevamento.
- **NON** permettere ai bambini di avvicinarsi alla base di sollevamento quando si aziona il meccanismo.
- **NON** sostare all'interno del letto o della base di contenimento interna.
- **NON** sovraccaricare la base di contenimento interna.
- **NON** saltare sul prodotto o sulle sue parti.

Español

IMPORTANTE PARA LAS CAMAS ELEVADORAS DE GAS&MANTENIMIENTO



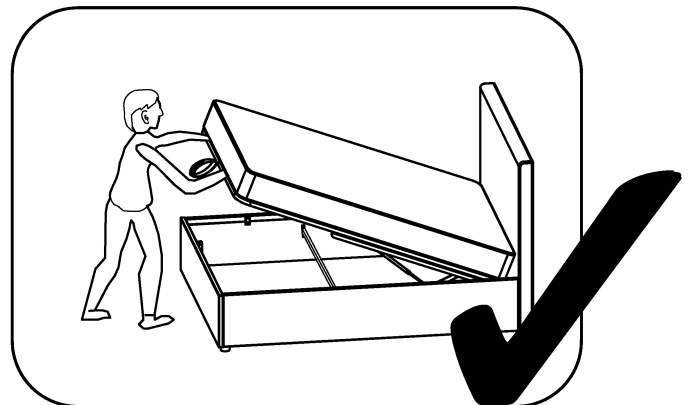
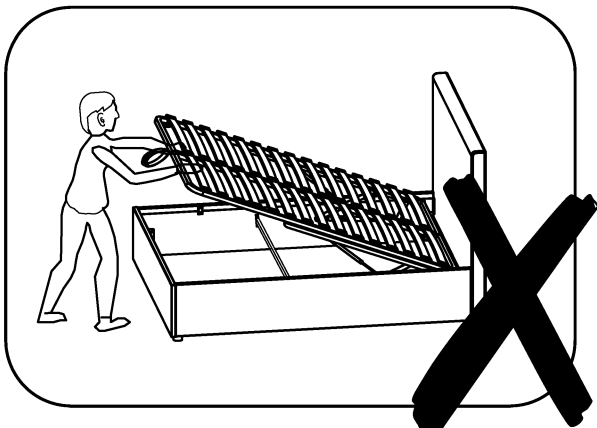

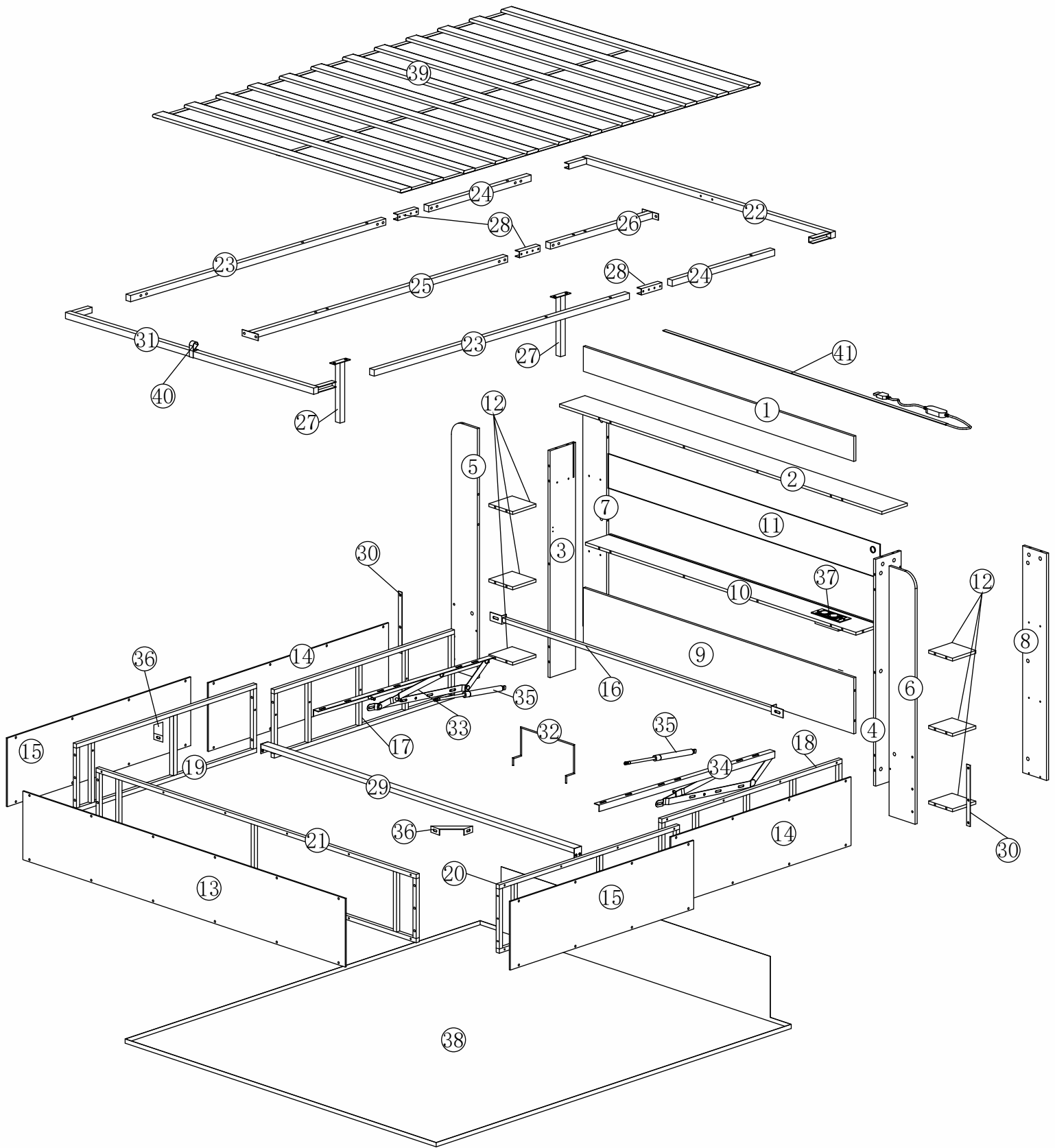

- Coloque el colchón sobre el somier.
- No tire de las asas de la correa.
- Presione con fuerza para liberar el gas comprimido.
- Compruebe periódicamente que todos los tornillos y fijaciones estén bien sujetos.
- Al mover el producto, levántelo con cuidado para colocarlo en su sitio.
- Limpie con un paño ligeramente humedecido; no utilice productos químicos abrasivos ni lejía.
- **NO** permita que los niños accionen el mecanismo de elevación.
- **NO** permita que los niños se acerquen a la base elevadora cuando accionen el mecanismo.
- **NO** se ponga de pie dentro de la cama o de la base de almacenamiento interna.
- **NO** sobrecargue el somier.
- **NO** salte sobre el producto ni sobre ninguna de sus piezas.



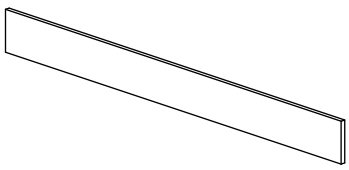
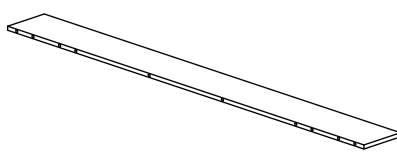

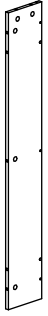

Part List-Teileliste-Liste des pièces

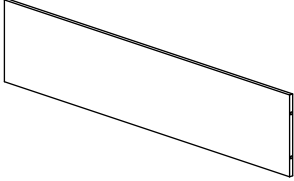
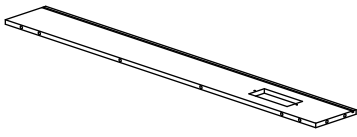
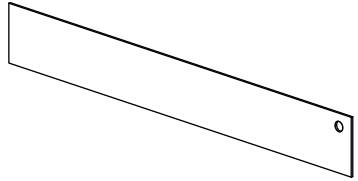
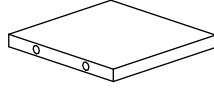
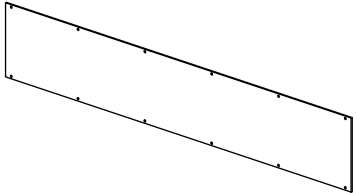
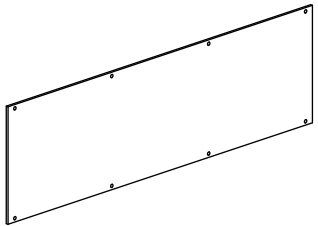
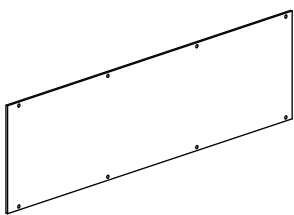
N623P444501

1  X1	2  X1	3  X1
4  X1	5  X1	6  X1
7  X1	8  X1	9  X1
10  X1	11  X1	12  X6
13  X1	14  X2	15  X2

Part List-Teileliste-Liste des pièces

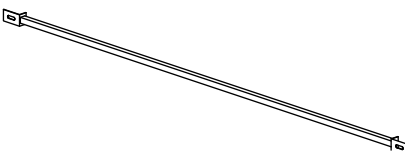
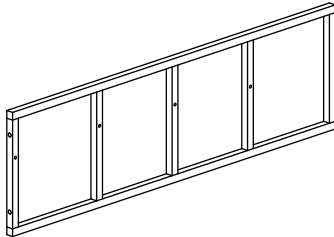
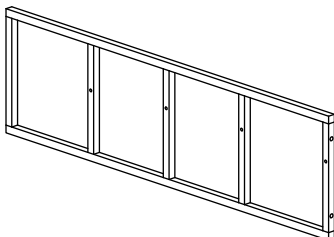
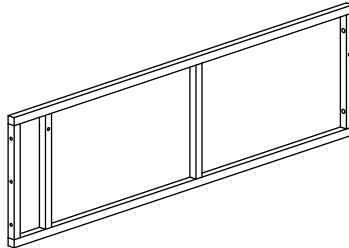
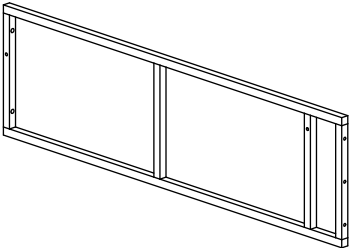
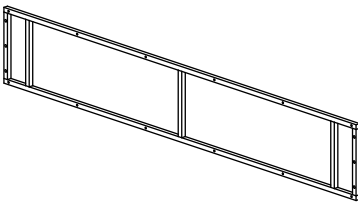
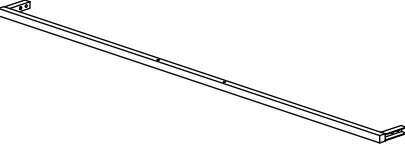
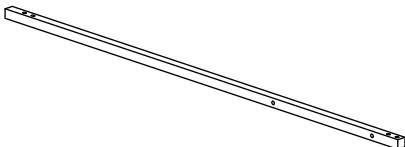
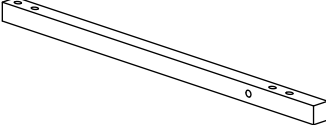
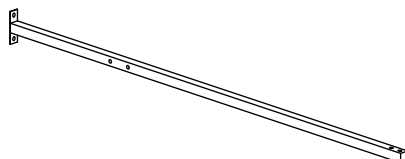
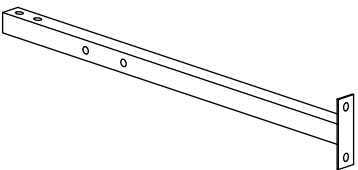
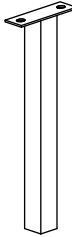
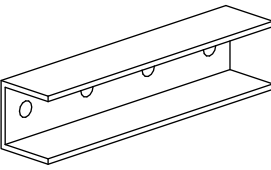
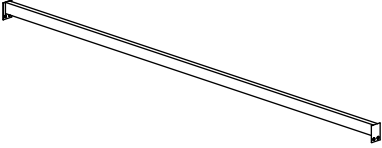
N623P444502

16  X1	17  X1	18  X1
19  X1	20  X1	21  X1
22  X1	23  X2	24  X2
25  X1	26  X1	27  X2
28  X3	29  X1	30  X2





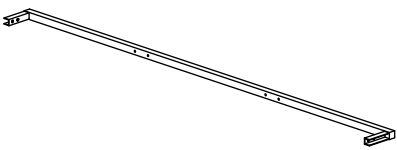
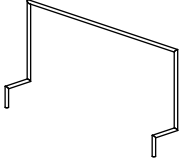
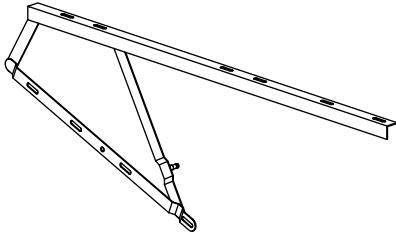
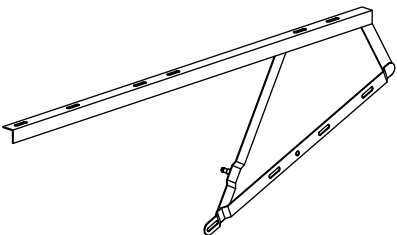
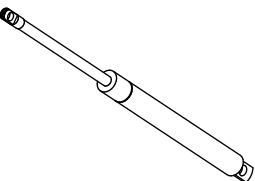
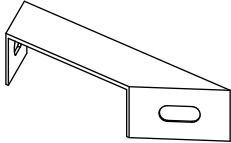
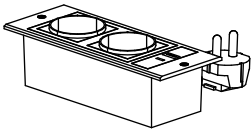
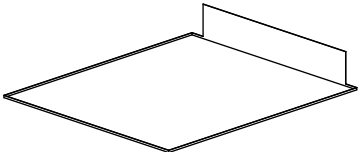
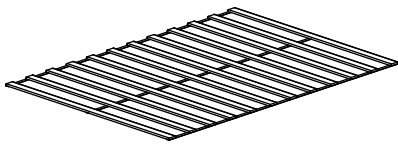
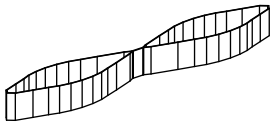
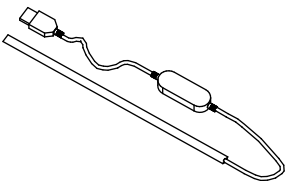







Part List-Teileliste-Liste des pièces













N623P444502



31  X1	32  X1	33  X1
34  X1	35  X2	36  X2
37  X1	38  X1	39  X1
40  X1	41  X1	

Hardware List-Hardware-Liste-Liste du matériel

N623P444502

A		M6X35MM	X60
B		φ 15X9MM	X60
C		φ 8X30MM	X16
D		φ 21X1MM	X6
E		φ 3. 5X30MM	X2
F			X2
G			X2
H		φ 3. 5X12MM	X18
I		M6X10MM	X20
J		M6X25MM	X6
K		M8X15MM	X6
L		M8X12MM	X6
M		M6X30MM	X10

N		M6X15MM	X50
O		M6*12MM	X10
P		M8	X8
Q		M4	X1
R		M5	X1
S		M8	X1
T		M6	X14
U		M8X35MM	X10
V		M8	X10
W			X4
X			X2
Y			X4



I		M6X10MM	X20
N		M6X15MM	X50
M		M6X30MM	X10

J		M6X25MM	X6
---	--	---------	----

DE:Bitte beachten Sie, dass die Formen der Schrauben I und J und M und N ähnlich sind. Bitte installieren Sie entsprechend der Anleitung und unterscheiden Sie sie!

UK:Please note that the shapes of screws I and J and M and N are similar. Please install according to the instructions and distinguish them!

FR:Notez que les vis I et J et M et N ont des formes similaires. Veuillez les installer en suivant les instructions pour les sépare

U		M8X35MM	X10
K		M8X15MM	X6
L		M8X12MM	X6

DE:Bitte beachten Sie, dass die Formen der Schrauben W und K und L ähnlich sind. Bitte installieren Sie entsprechend der Anleitung und unterscheiden Sie sie!

UK:Please note that the shapes of screws W and K and L are similar. Please install according to the instructions and distinguish them!

FR:Notez que les vis W et K et L ont des formes similaires. Veuillez les installer en suivant les instructions pour les sépare!

1

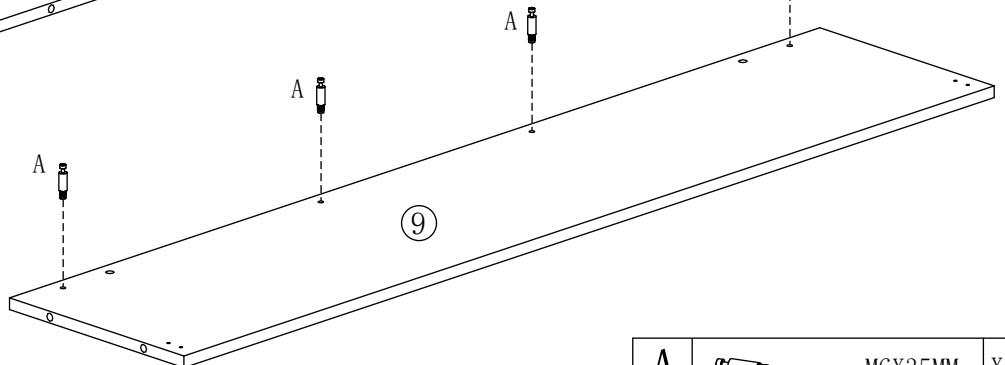
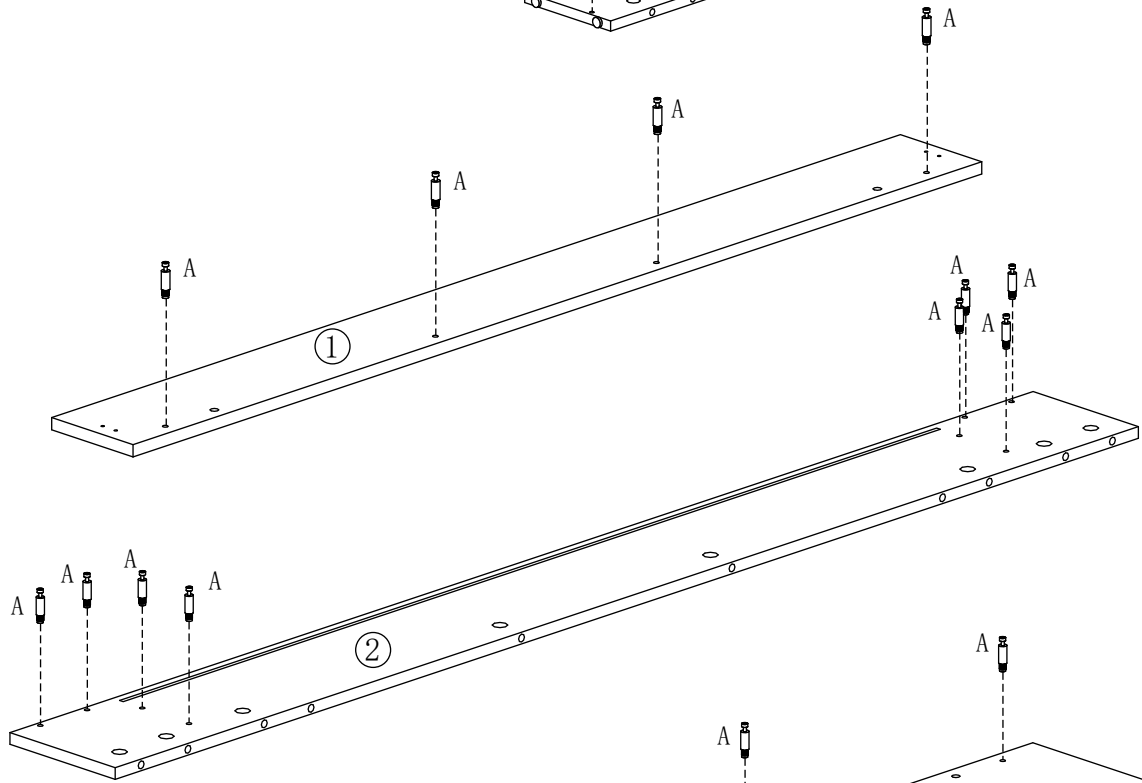
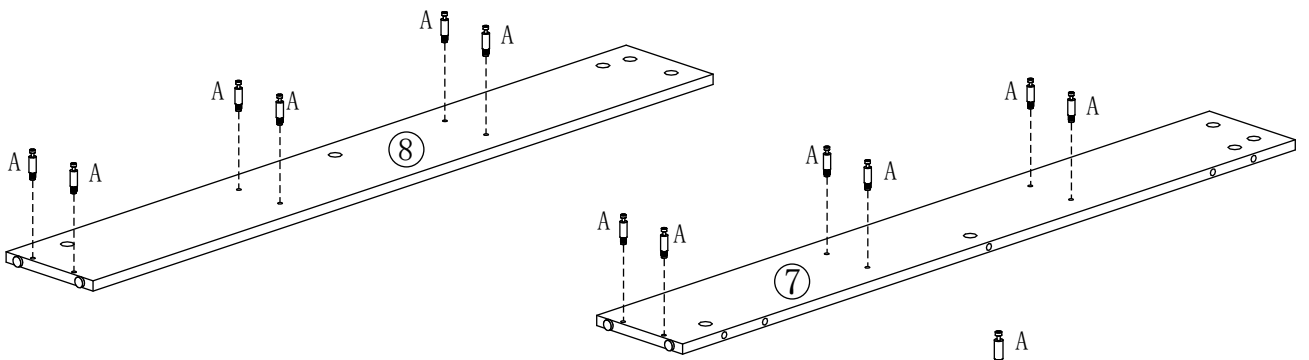
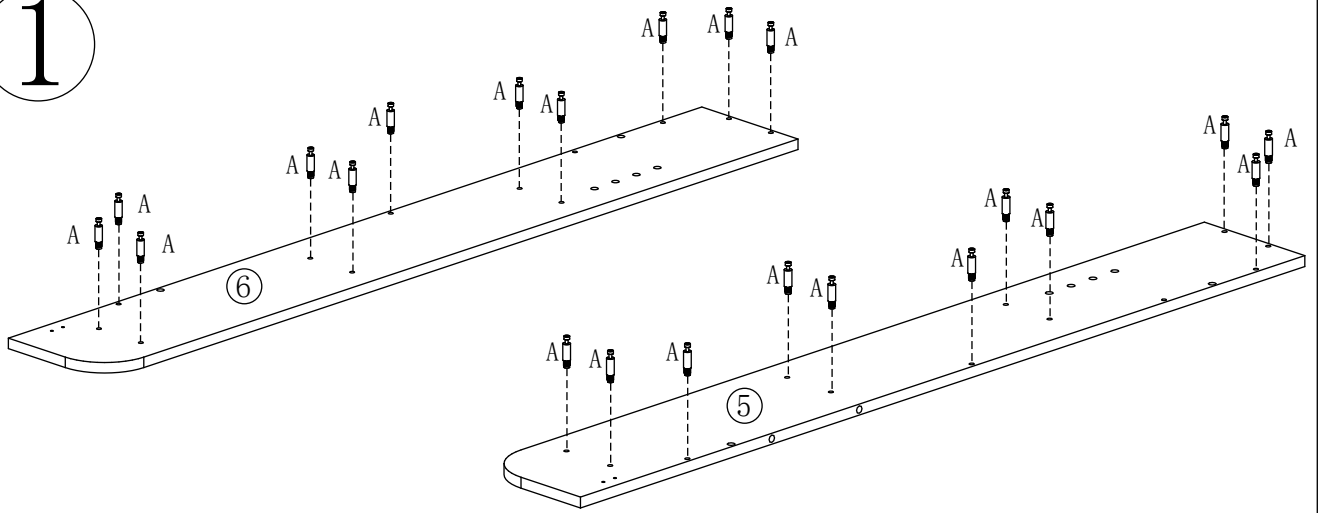

A		M6X35MM	X50
---	---	---------	-----

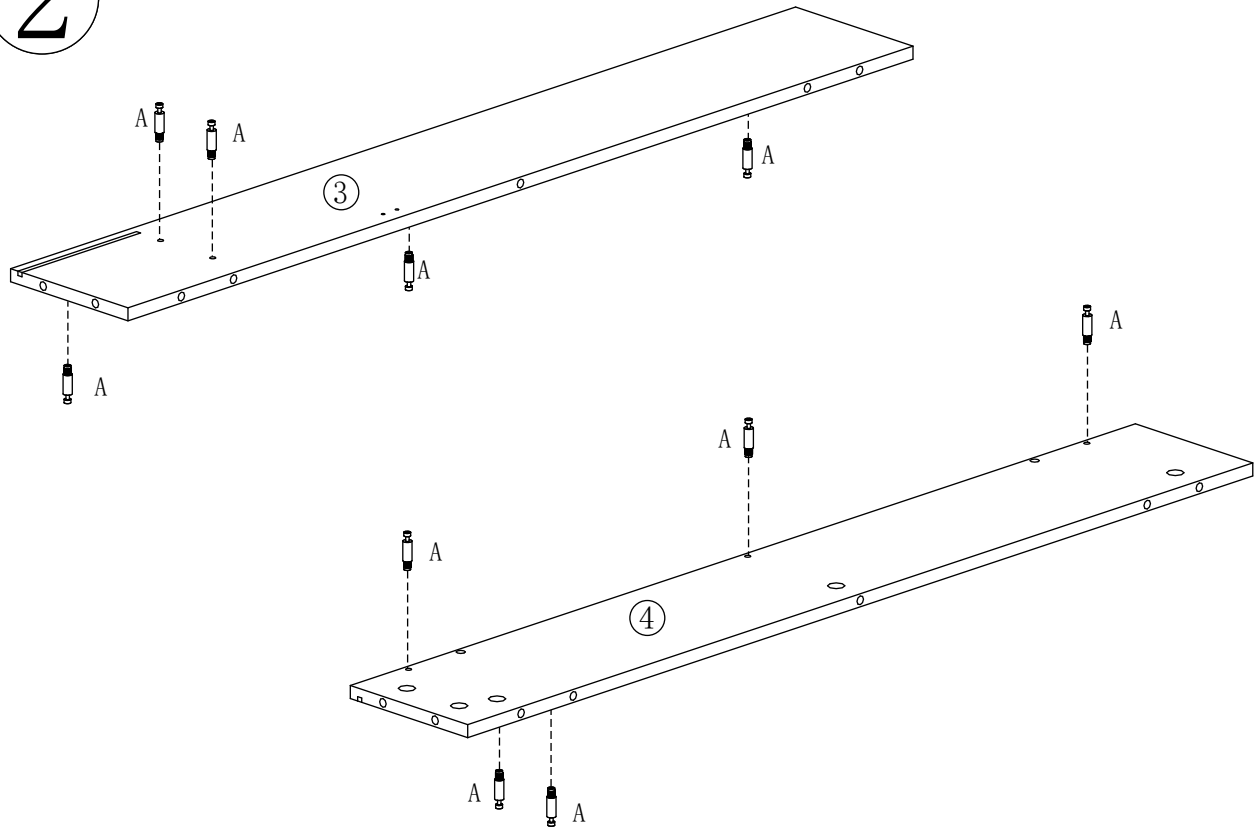

2

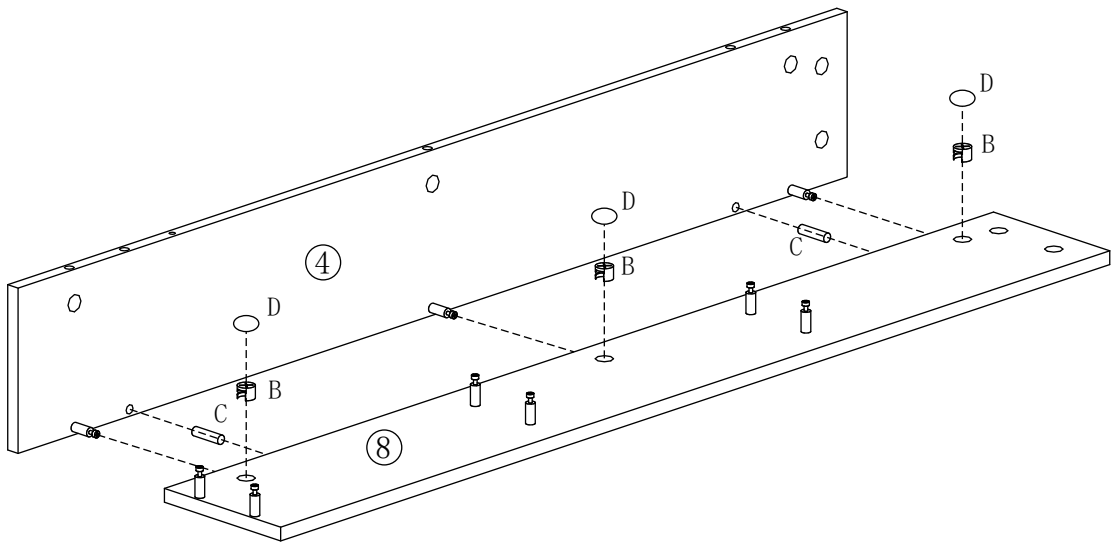

A		M6X35MM	X10
---	---	---------	-----

3



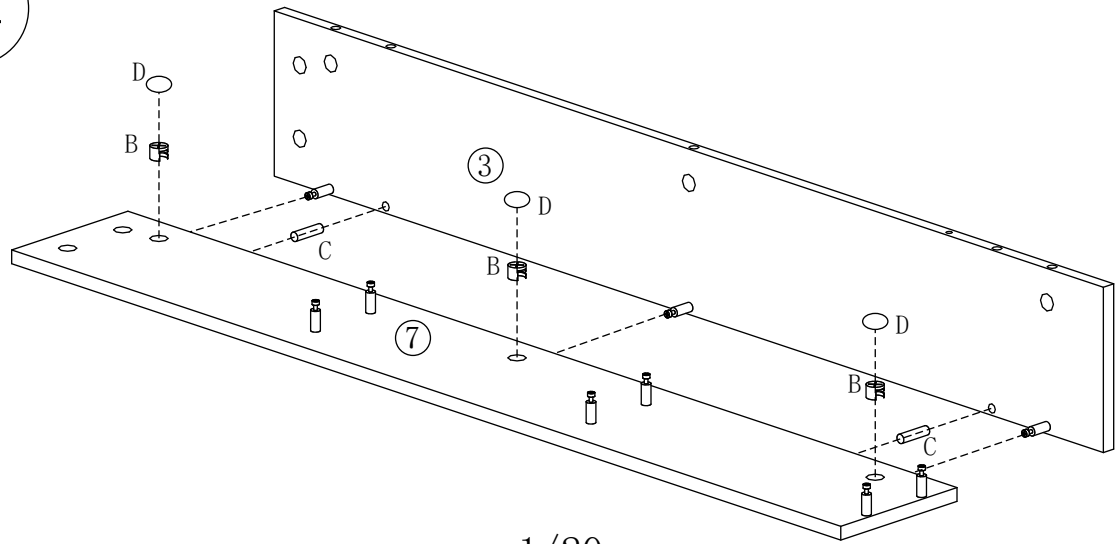

D		ϕ 21X1MM	X3
B		ϕ 15X9MM	X3
C		ϕ 8X30MM	X2

4



1/20

D		φ 21X1MM	X3
B		φ 15X9MM	X3
C		φ 8X30MM	X2

5

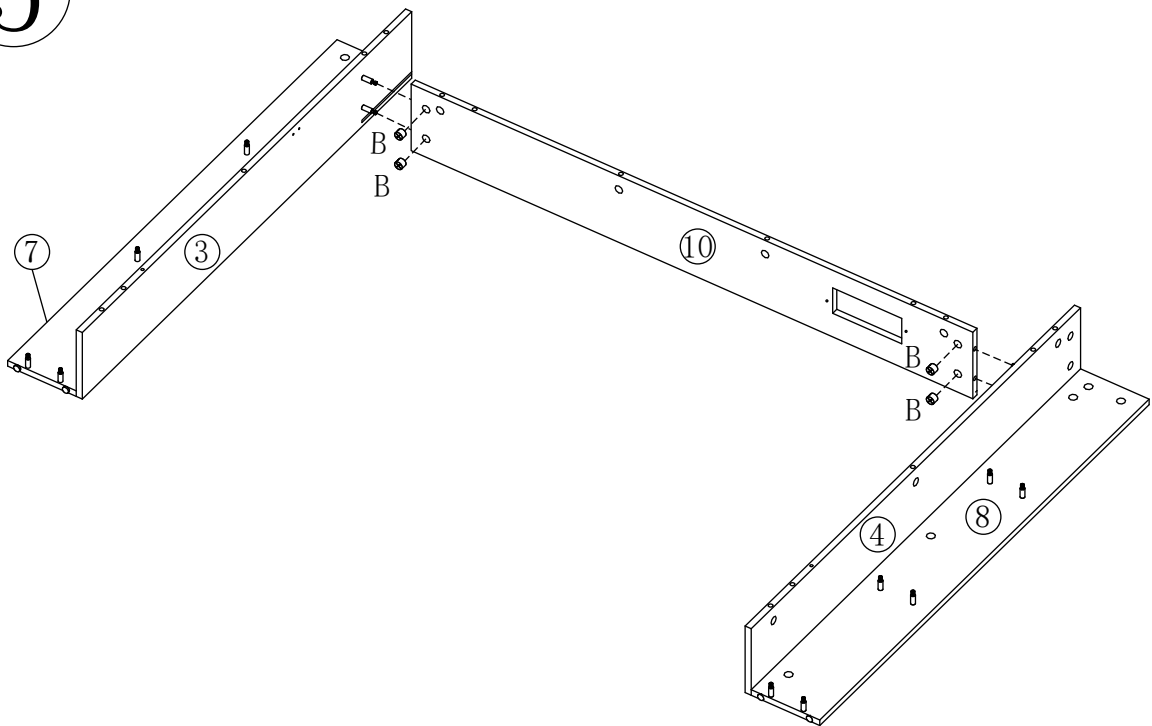

B		φ 15X9MM	X4
---	---	----------	----

6

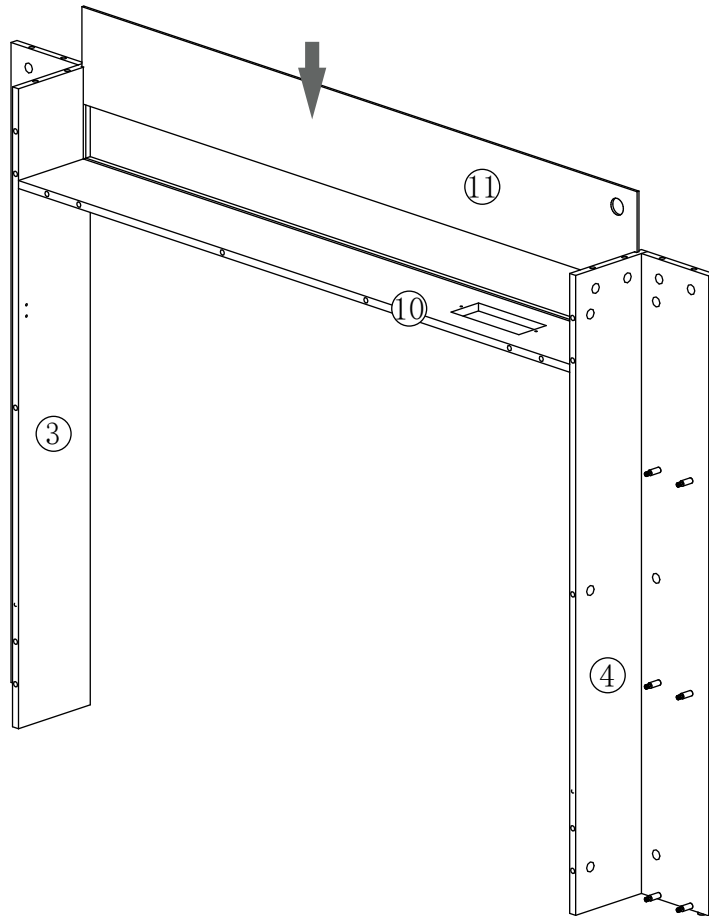

7

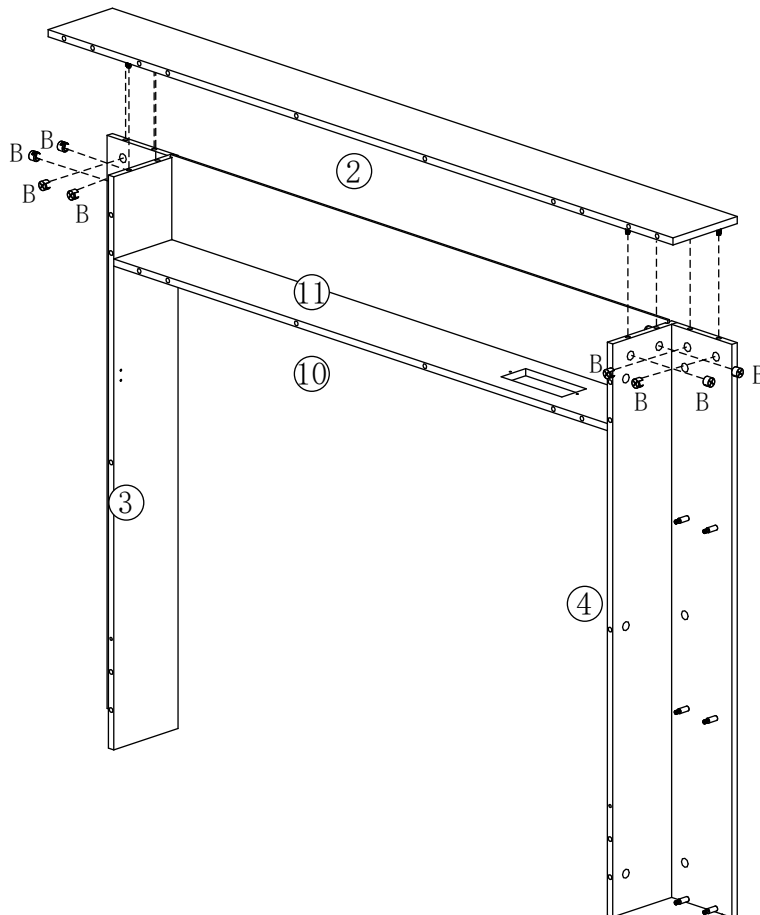

B		ϕ 15X9MM	X8
---	--	---------------	----

8

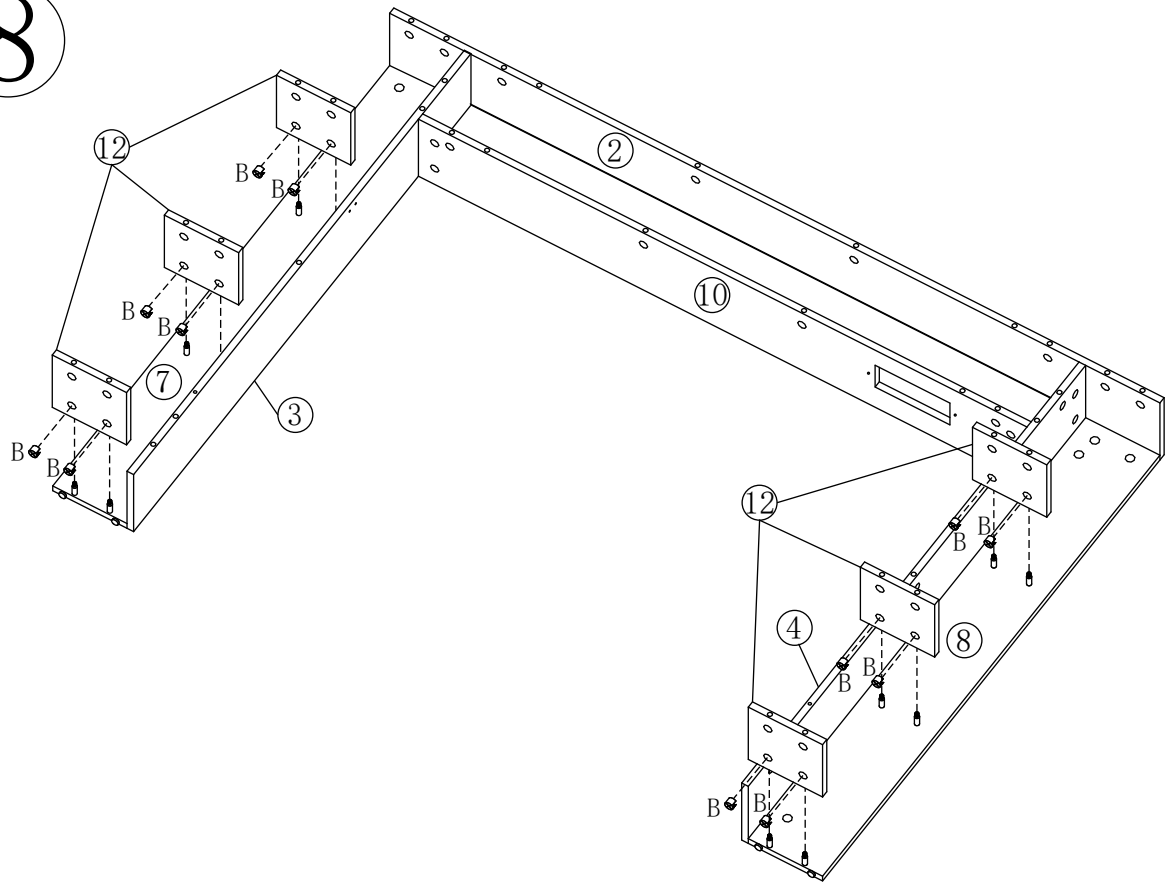

B		φ 15X9MM	X12
---	---	----------	-----

9

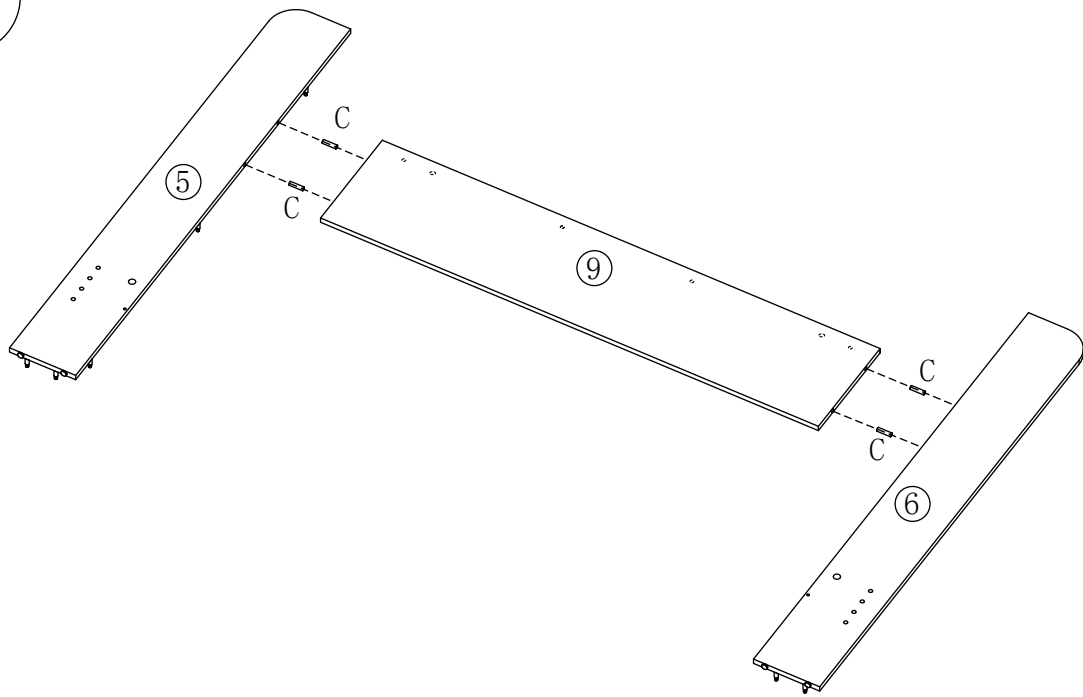

C		φ 8X30MM	X4
---	---	----------	----

10

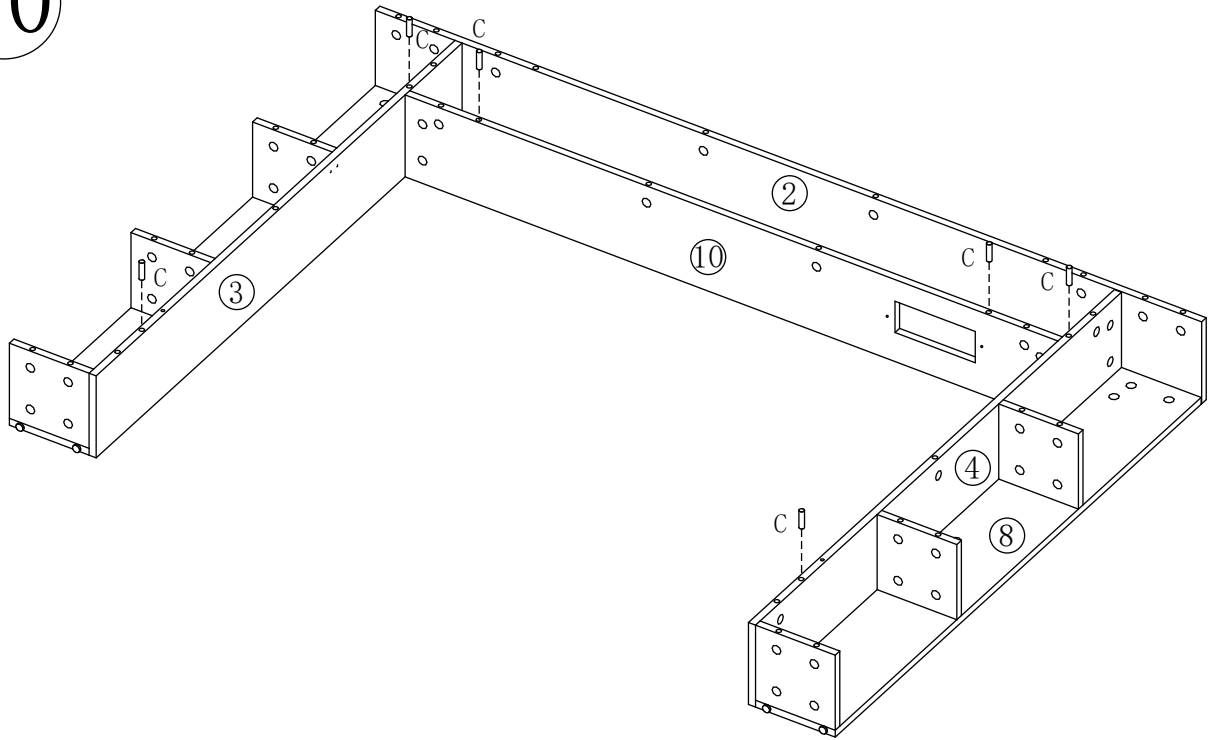

C		φ 8X30MM	X6
---	---	----------	----

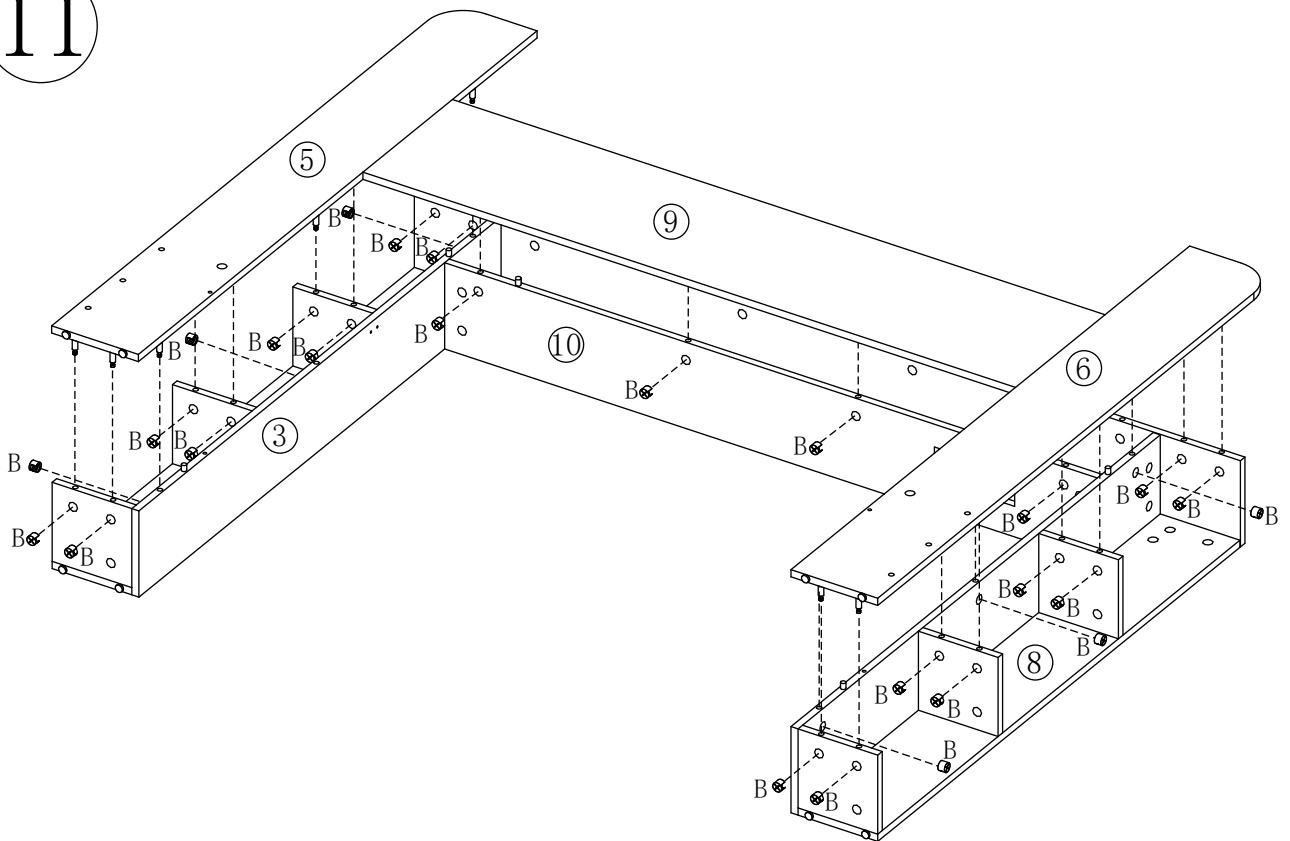

11



B		φ 15X9MM	X26
---	---	----------	-----

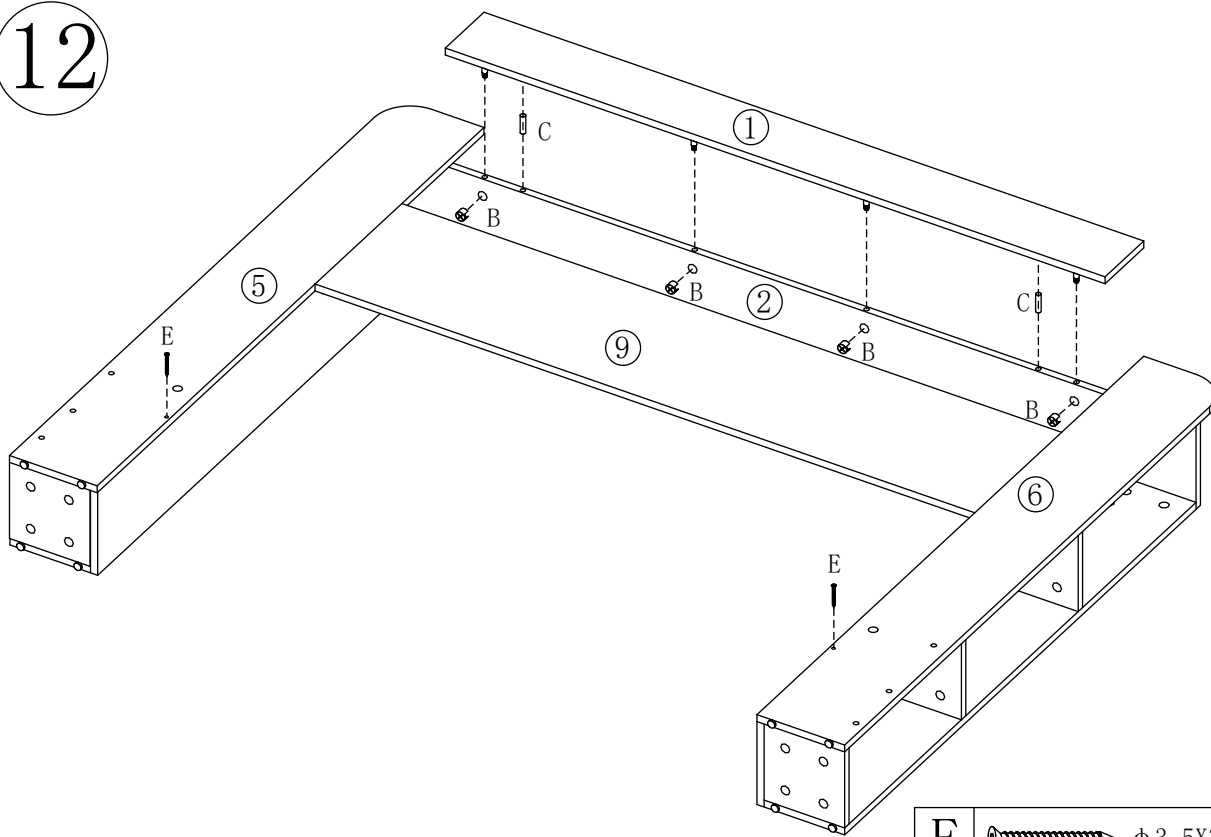

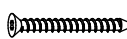

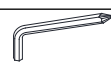
12

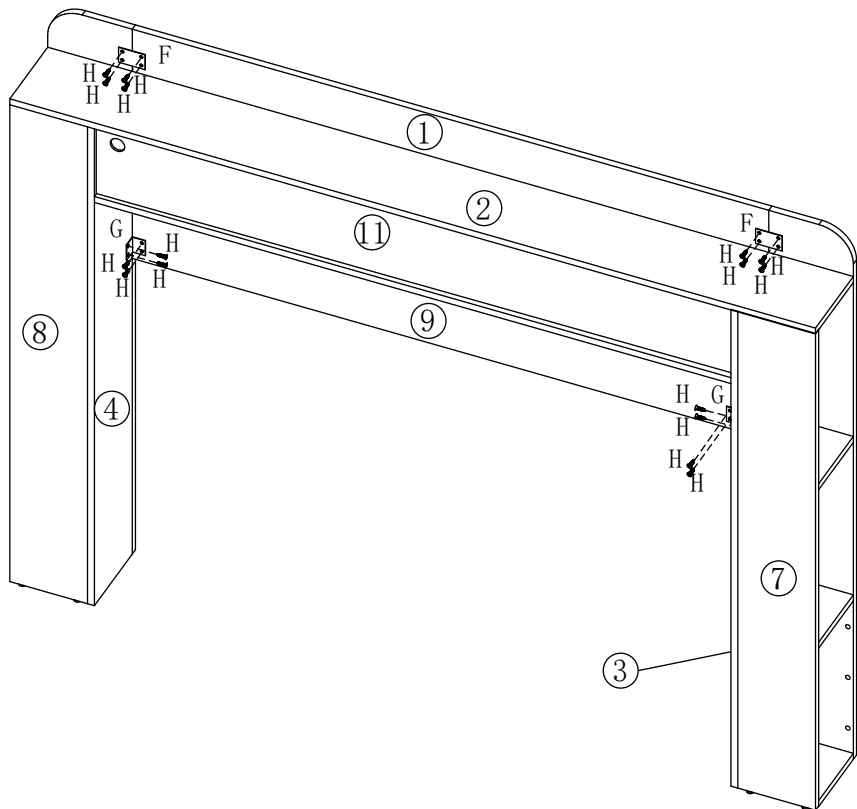

E		φ 3.5X30MM	X2
B		φ 15X9MM	X4
C		φ 8X30MM	X2
Q		M4	X1

13



F			X2
G			X2
H		φ 3.5X12MM	X16
Q		M4	X1

14

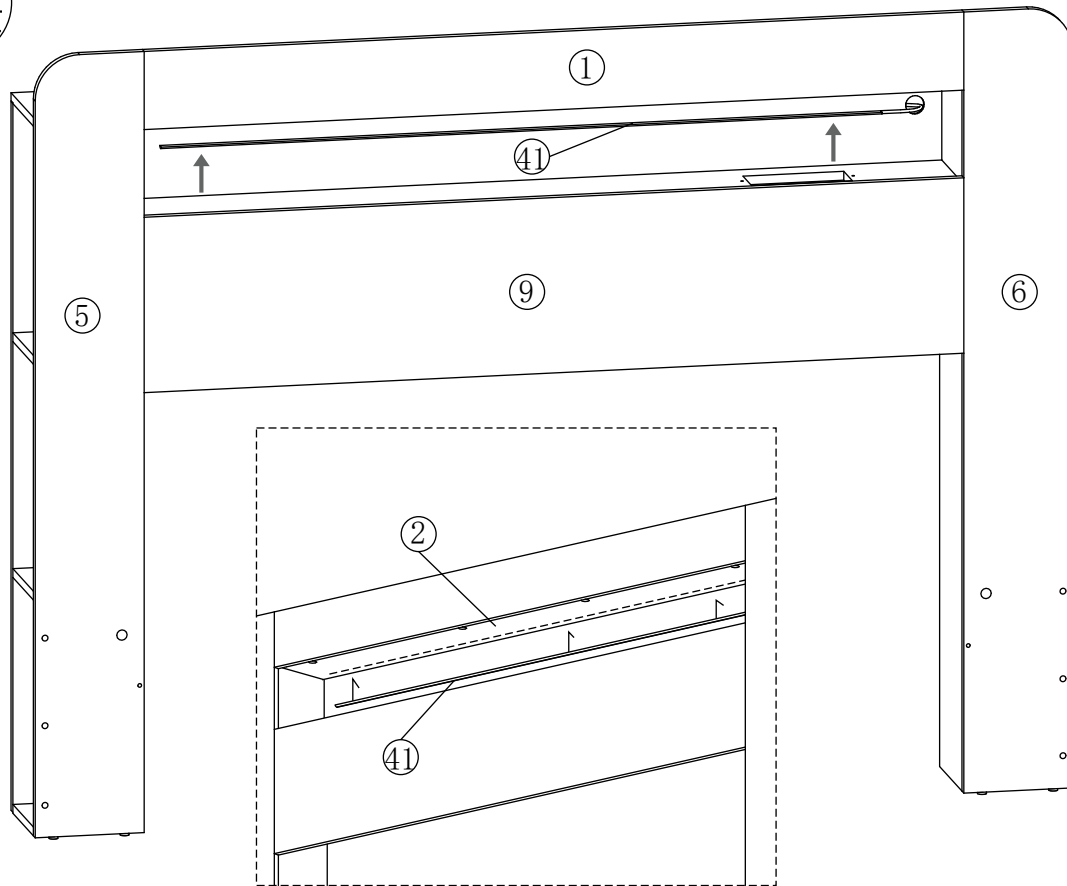

15

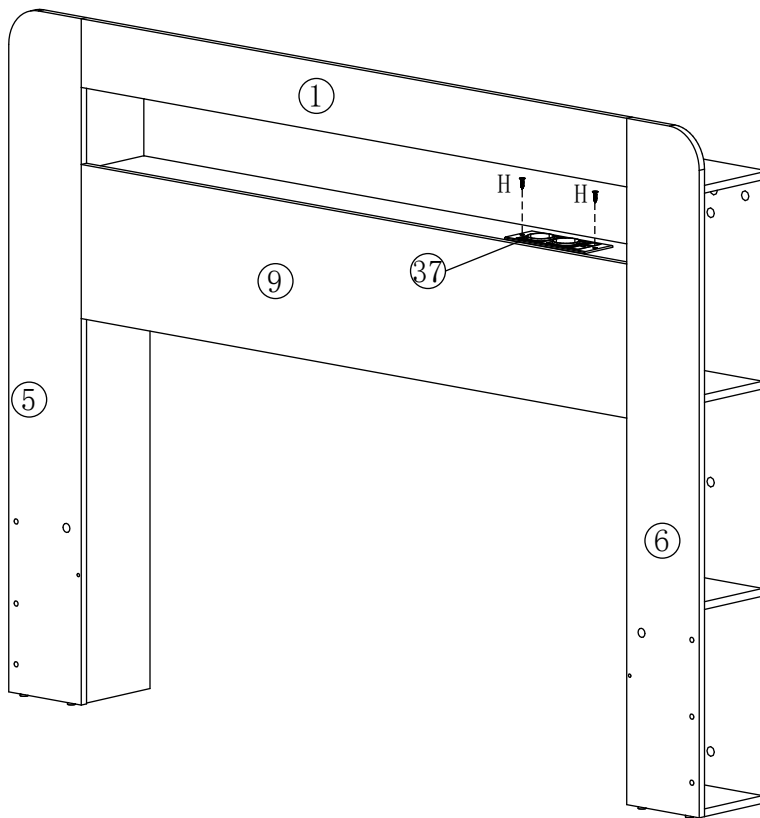

Q



M4

X1

H



Φ 3.5X12MM X2

16

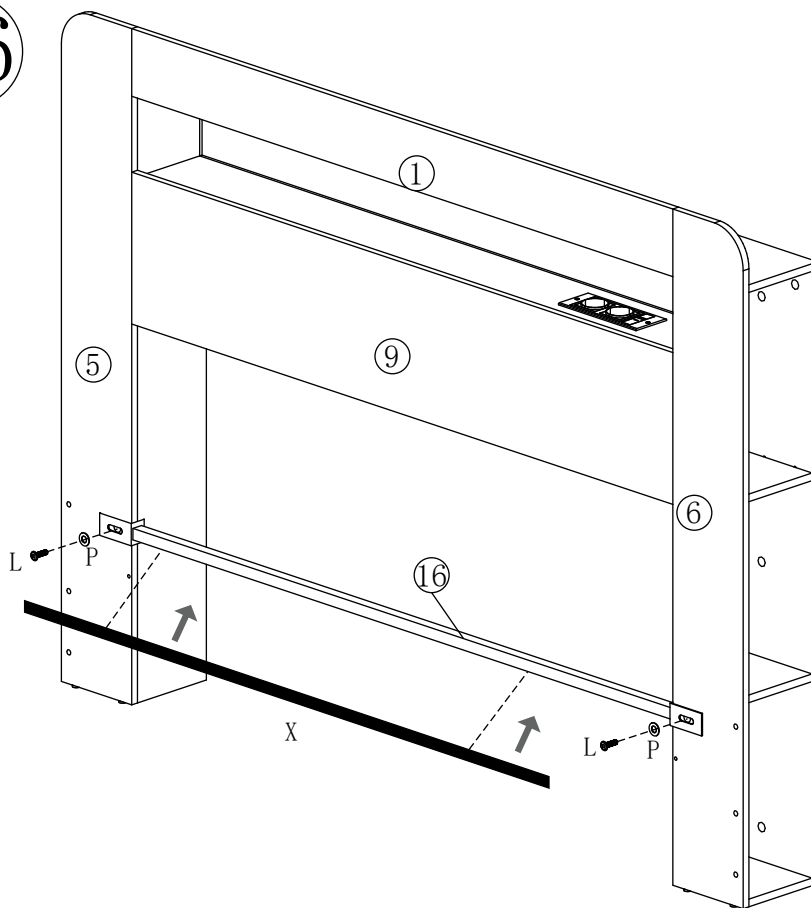

X		X1
---	--	----

R		M5	X1
P		M8	X2
L		M8X12MM	X2

17

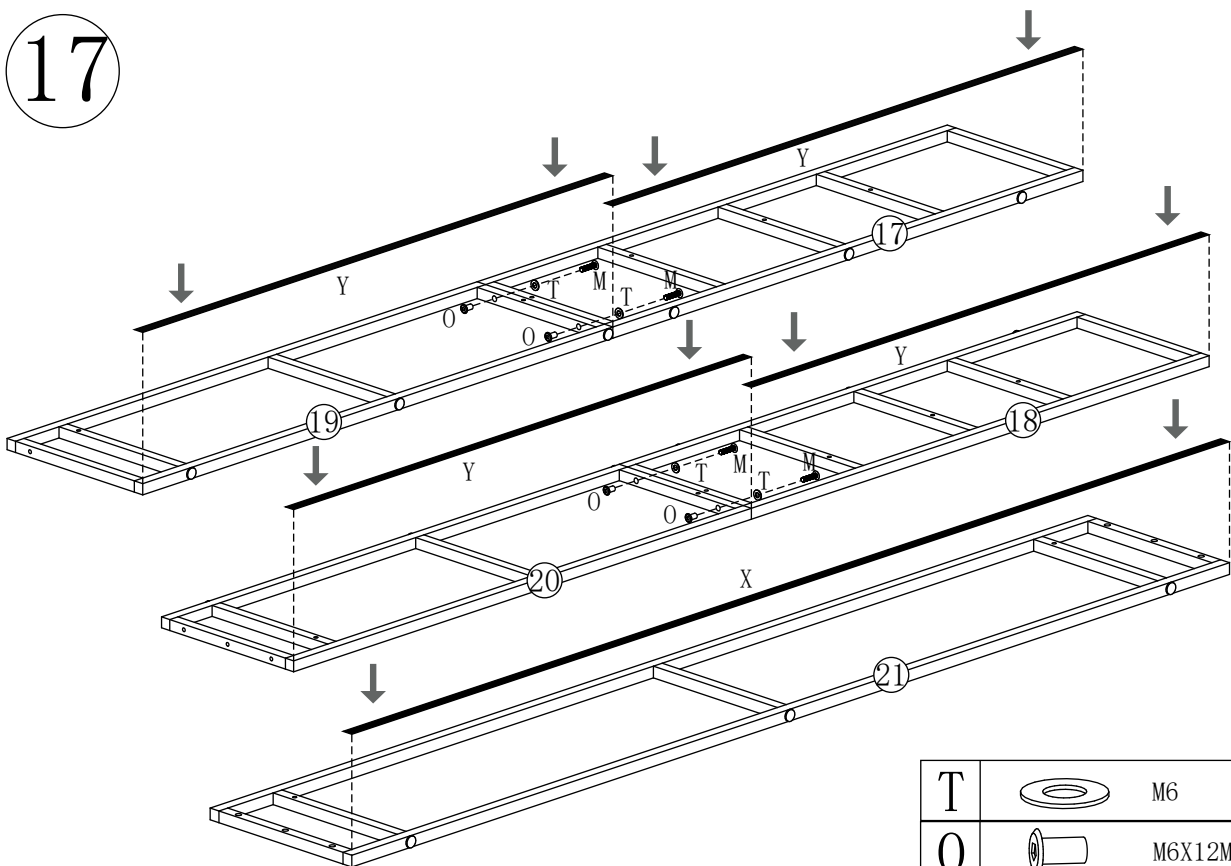



X		X1
Y		X4

T		M6	X4
O		M6X12MM	X4
Q		M4	X1
M		M6X30MM	X4

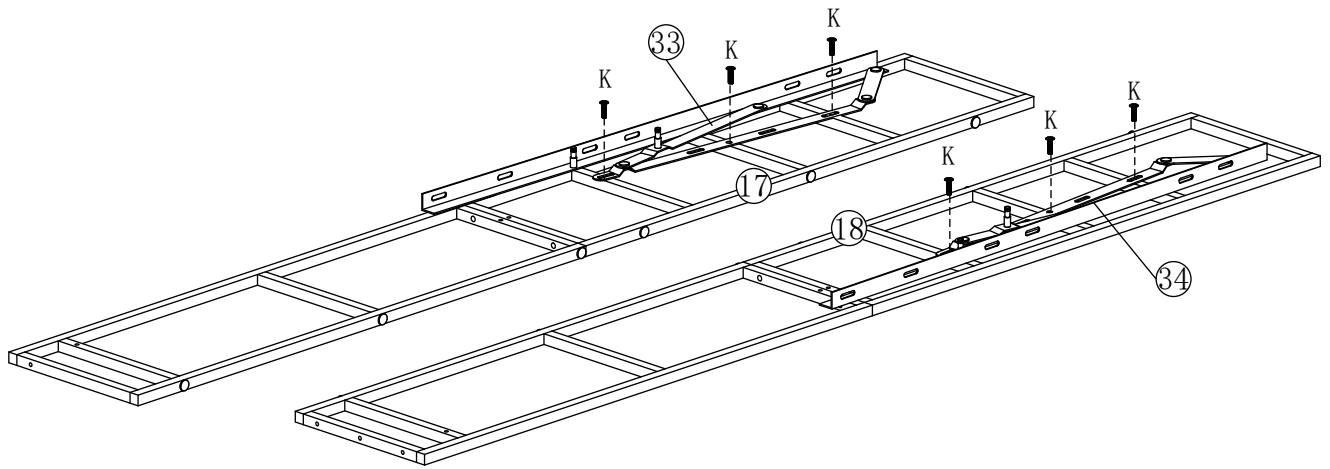



18

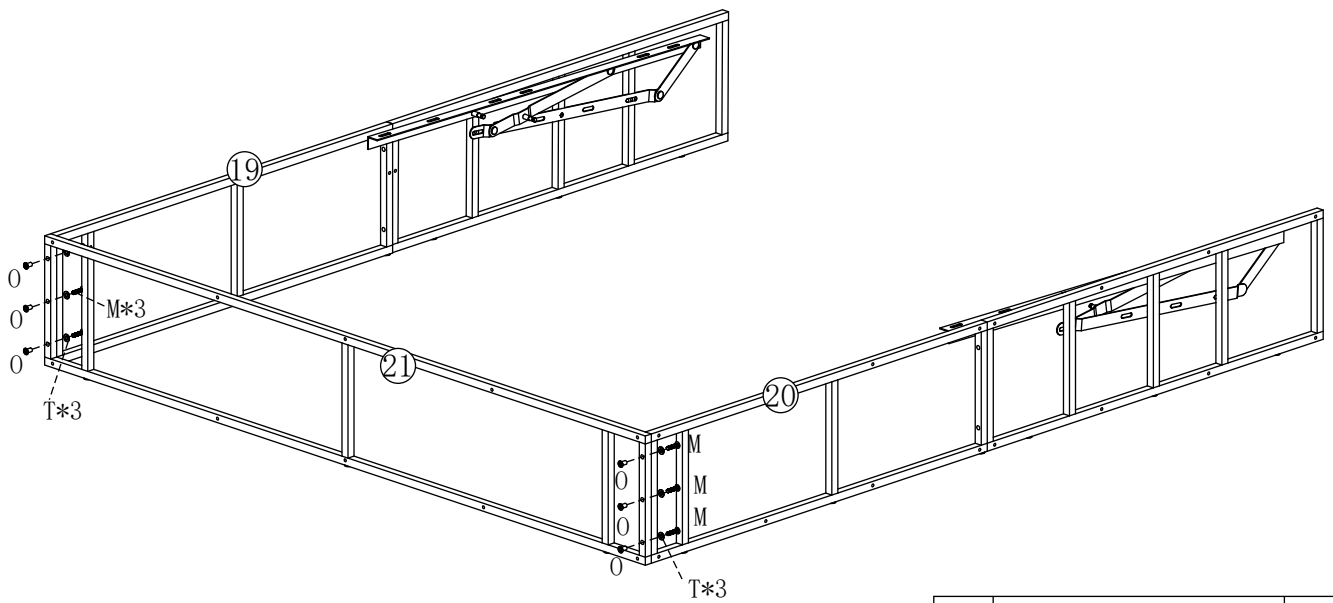

R		M5	X1
K		M8X15MM	X6





19

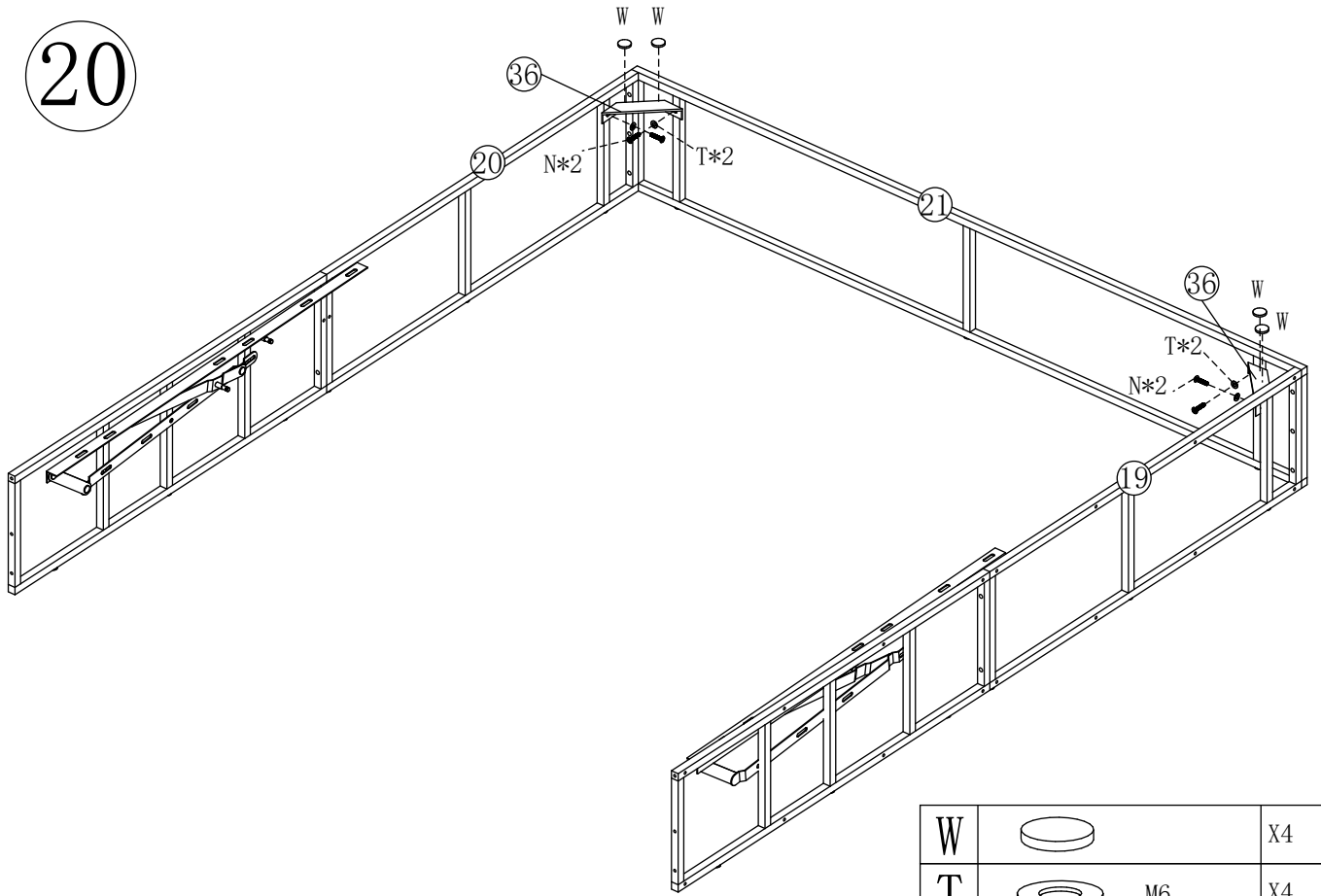

T		M6	X6
O		M6X12MM	X6
Q		M4	X1
M		M6X30MM	X6



20



W			X4
T		M6	X4
N		M6X15MM	X4
Q		M4	X1

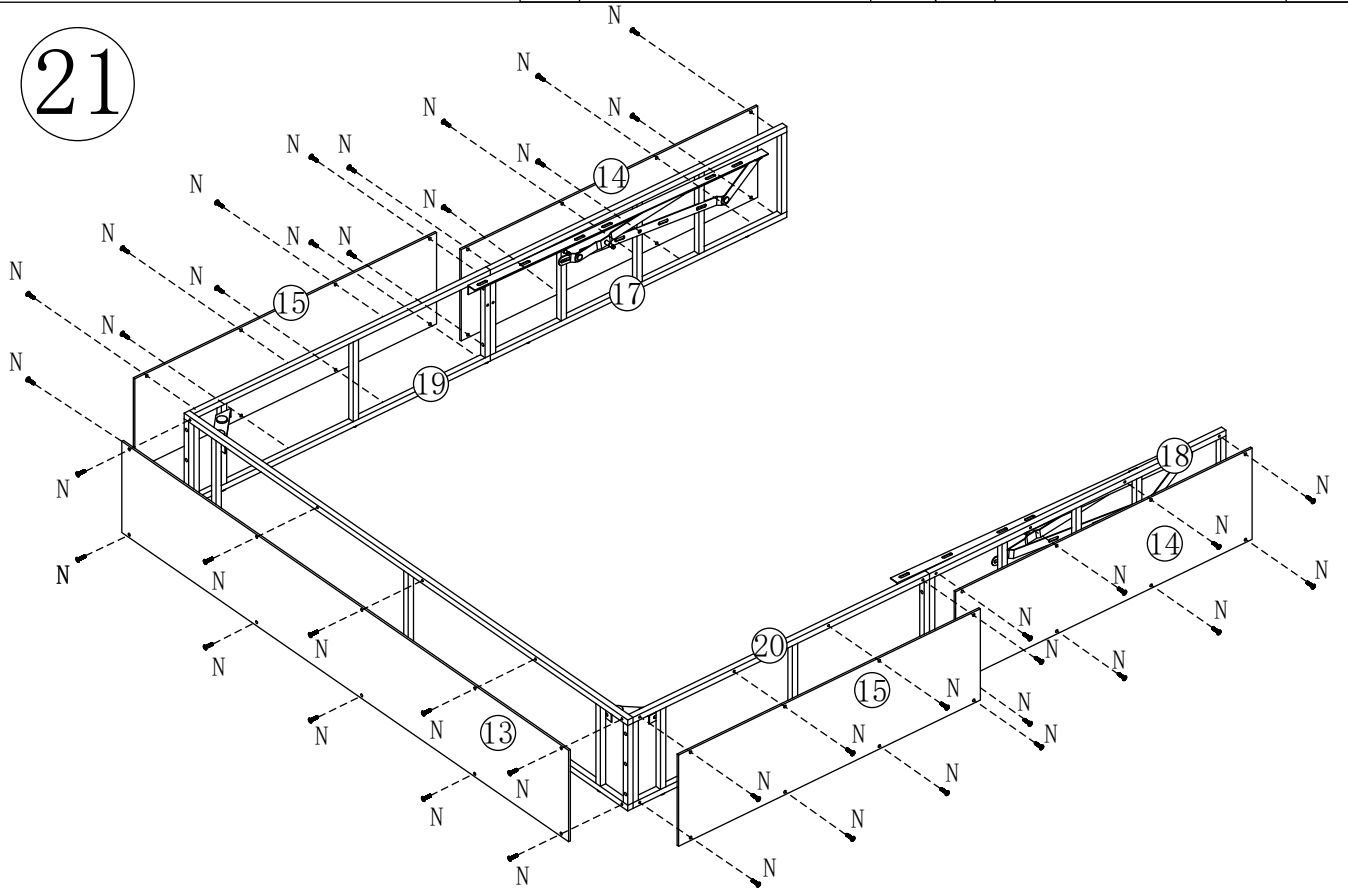

21



Q		M4	X1
N		M6X15MM	X42

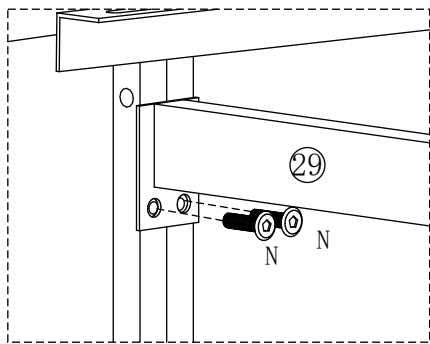
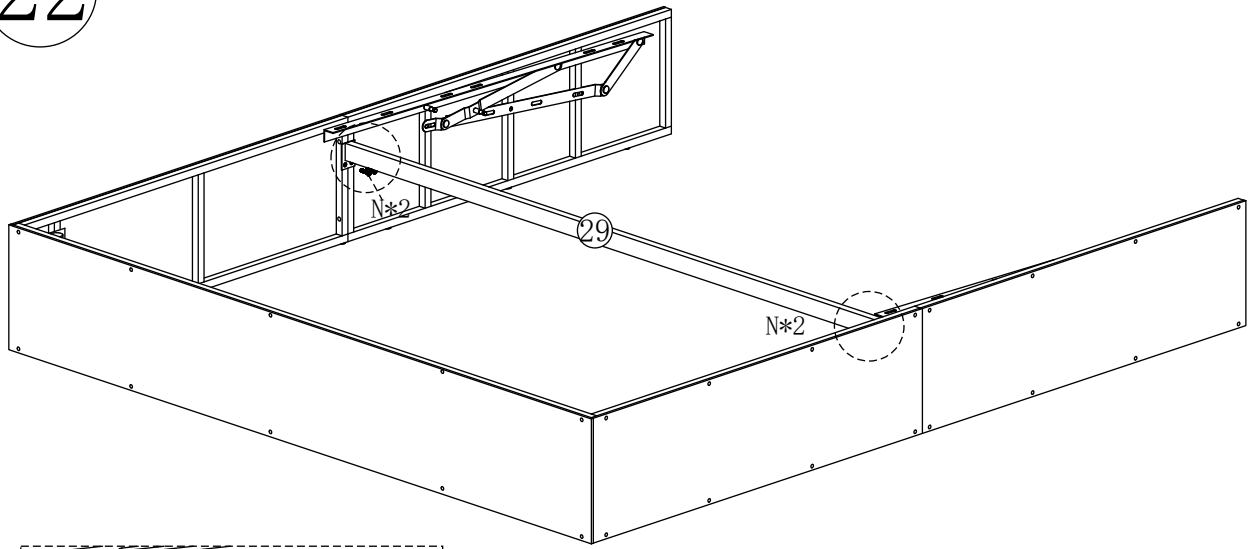

22

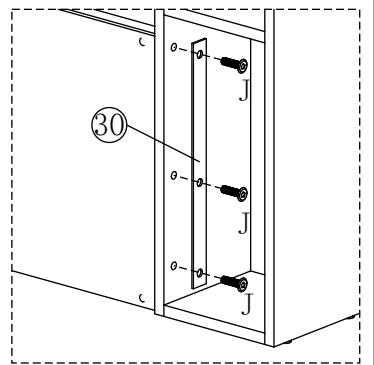
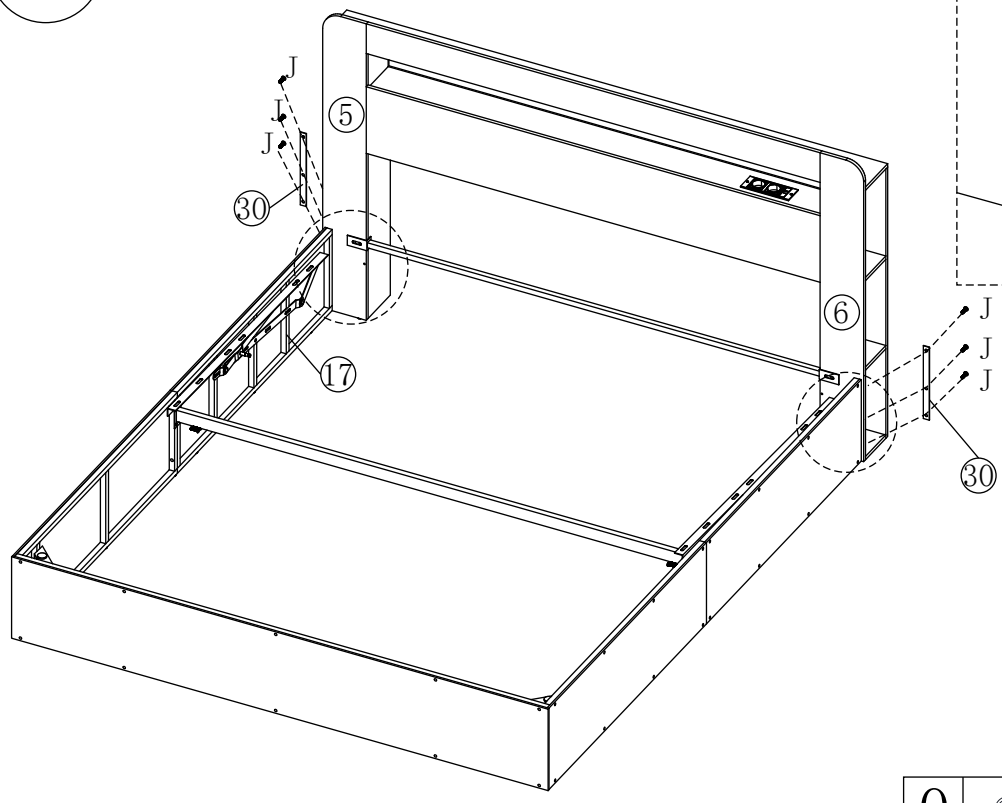

Q		M4	X1
N		M6X15MM	X4

23



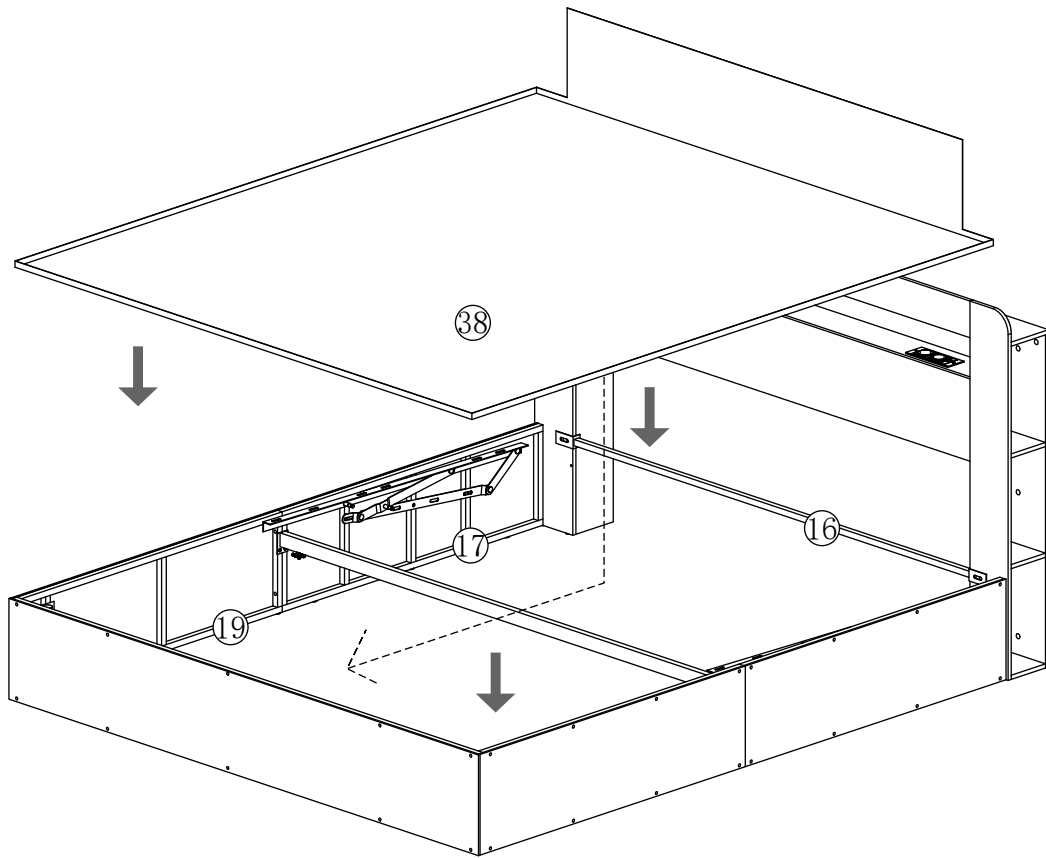

Q		M4	X1
J		M6X25MM	X6

24

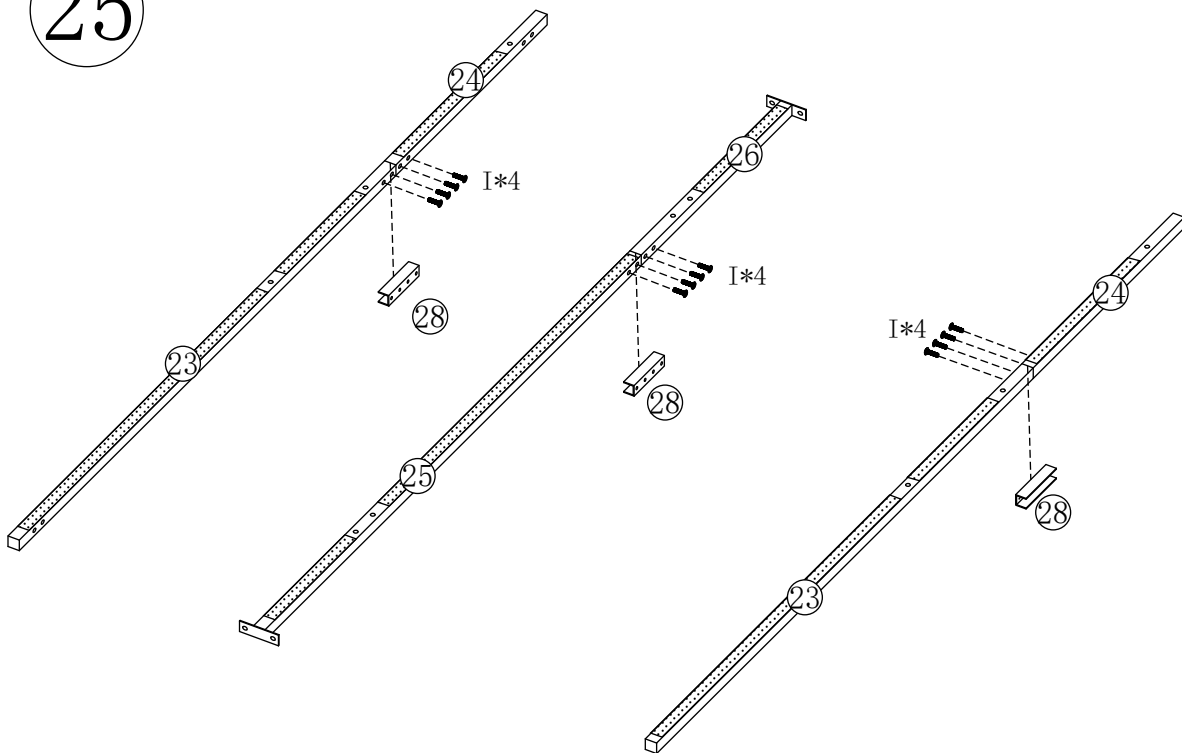

25



Q		M4	X1
I		M6X10MM	X12

26

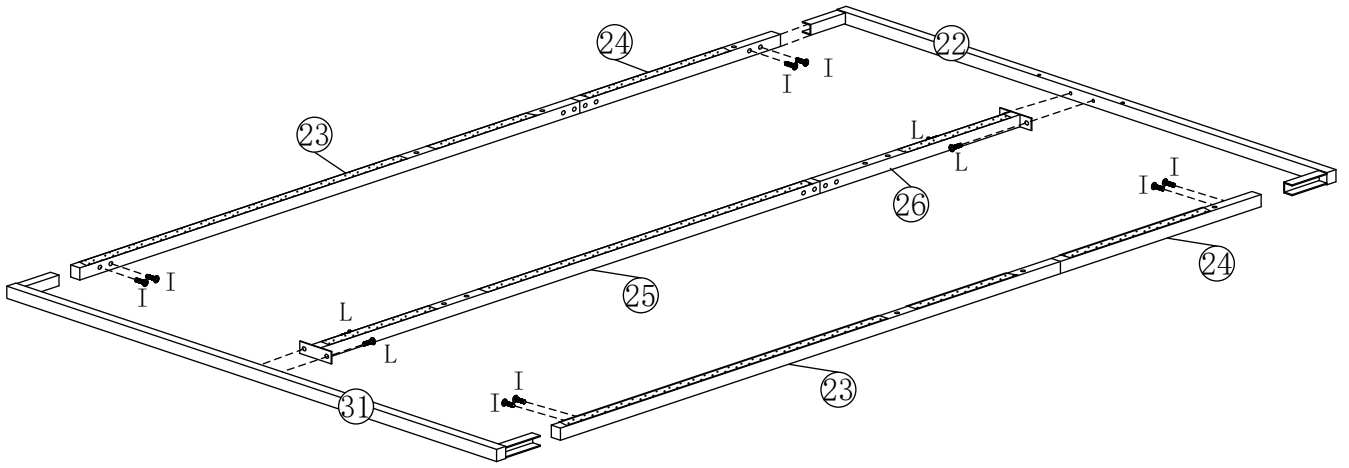

R		M5	X1
L		M8X12MM	X4
Q		M4	X1
I		M6X10MM	X8



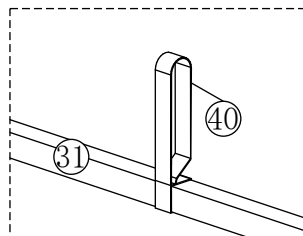
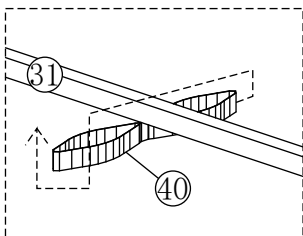
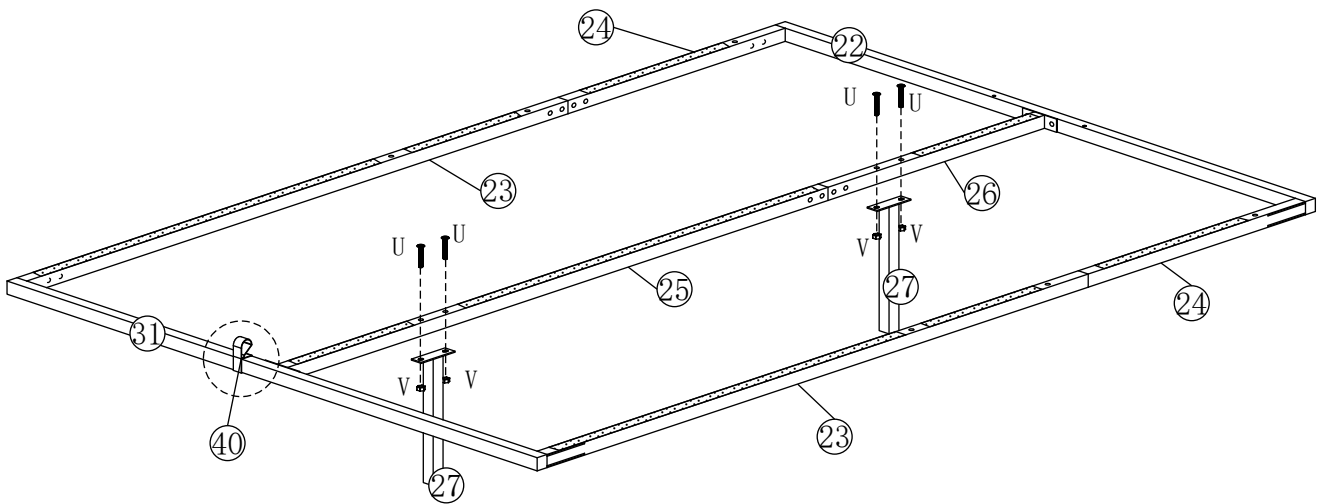

27

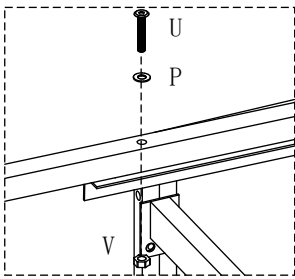
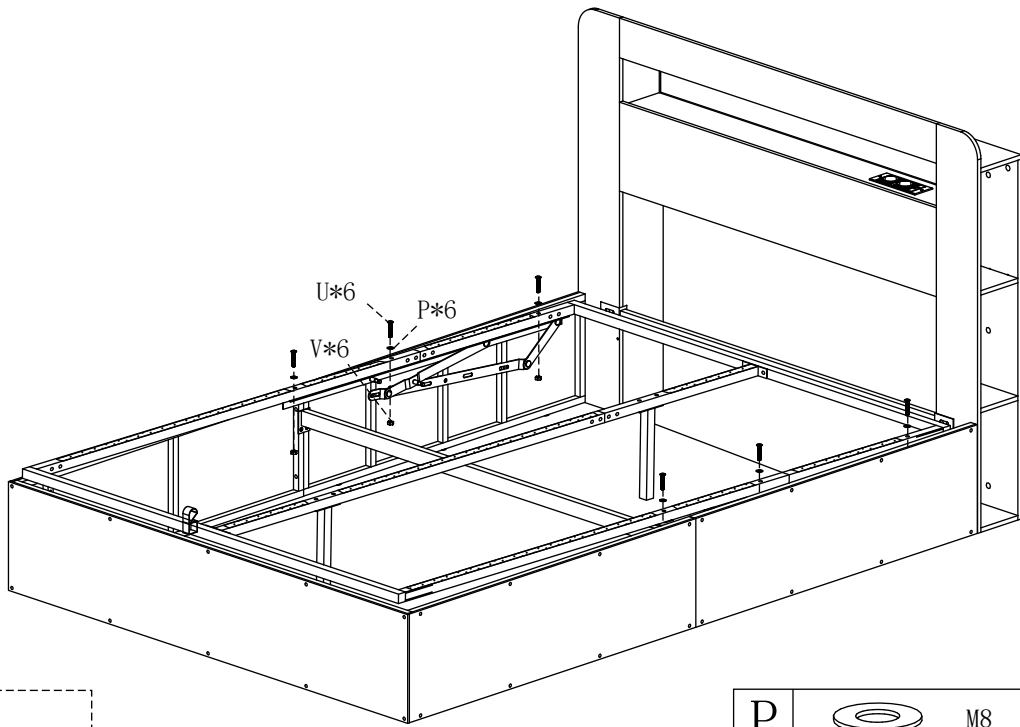

R		M5	X1
U		M8X35MM	X4
V		M8	X4
Z		M8	X1

28

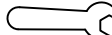

P		M8	X6
R		M5	X1
U		M8X35MM	X6
V		M8	X6
Z		M8	X1

29

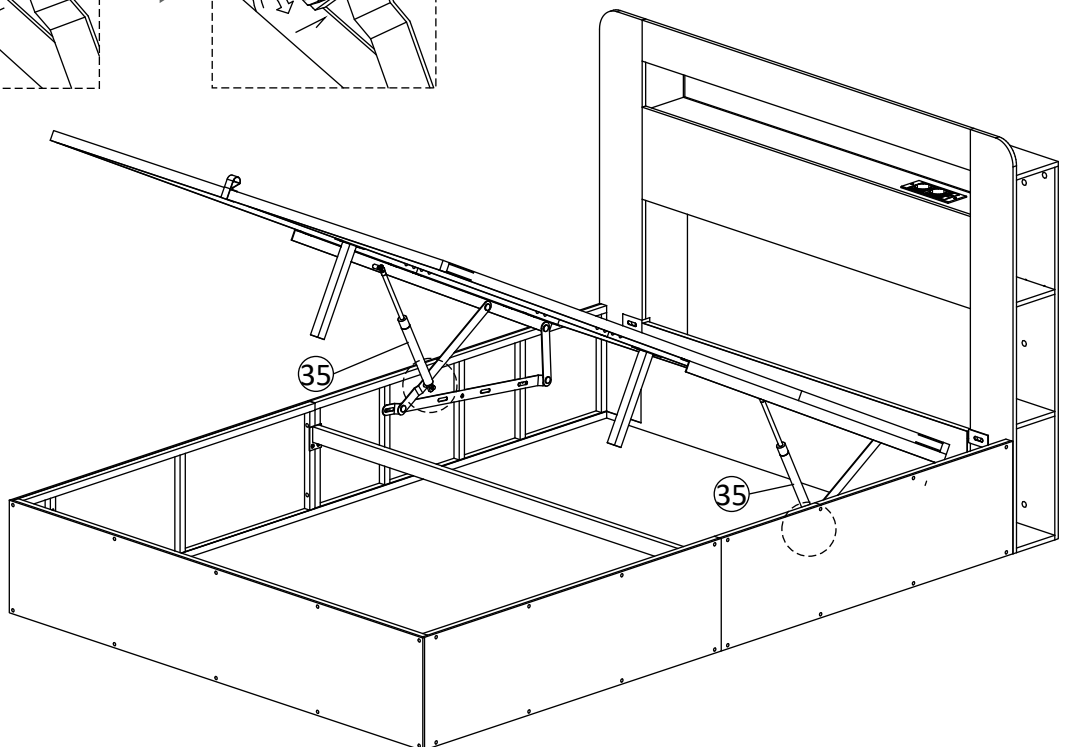
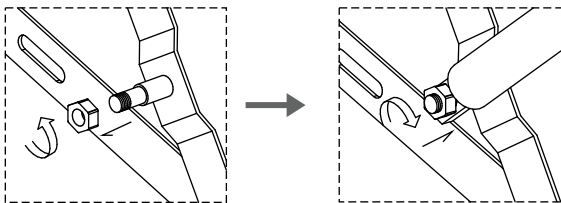

30

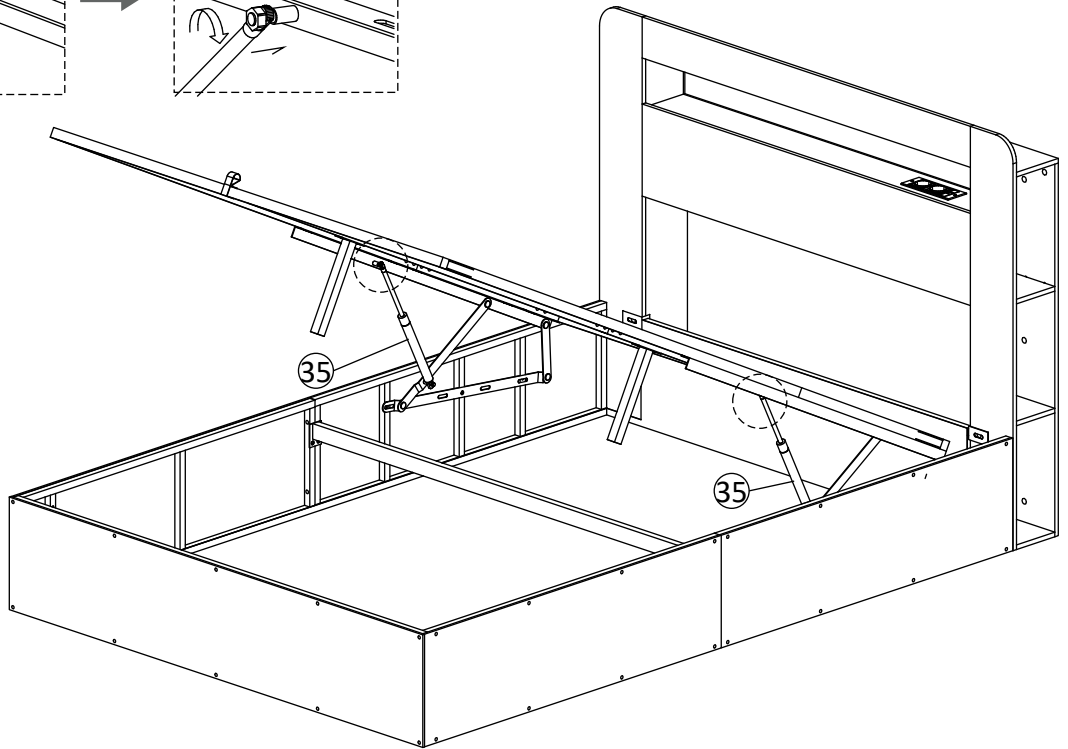
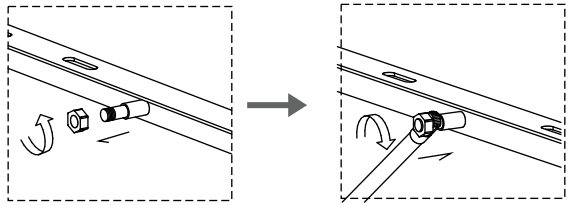

31

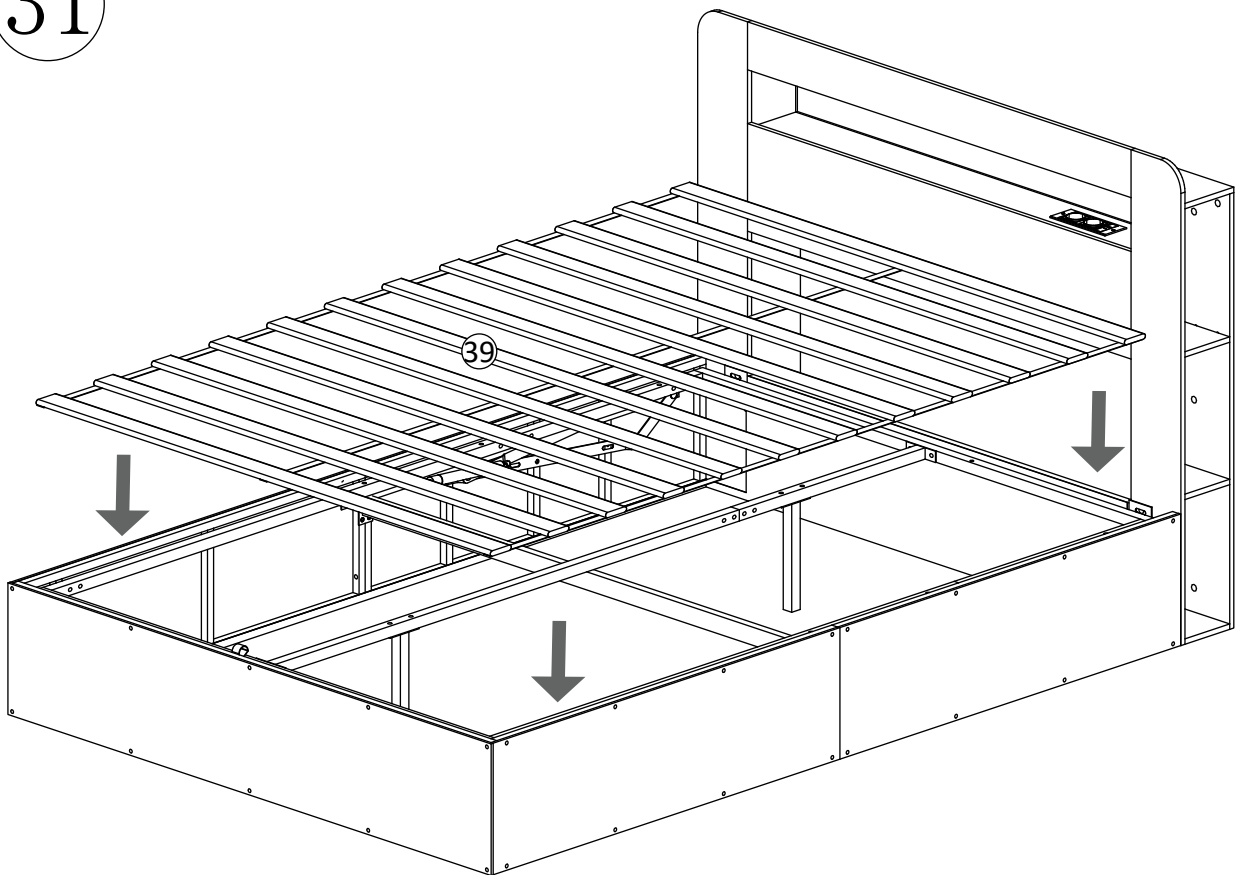

32

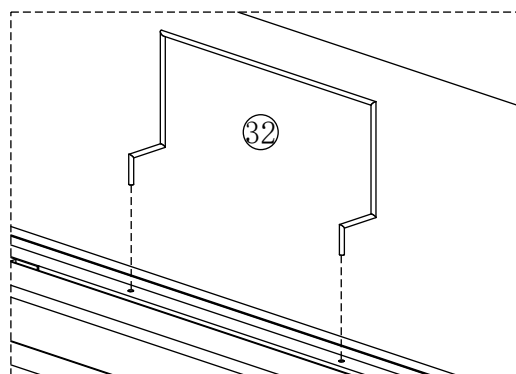
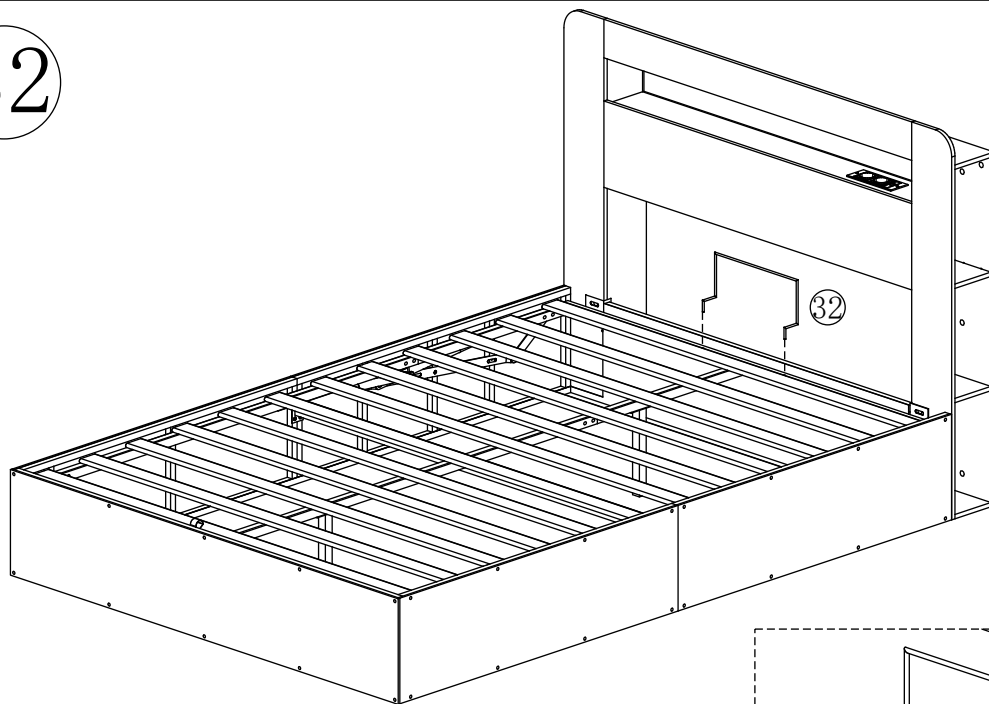

33

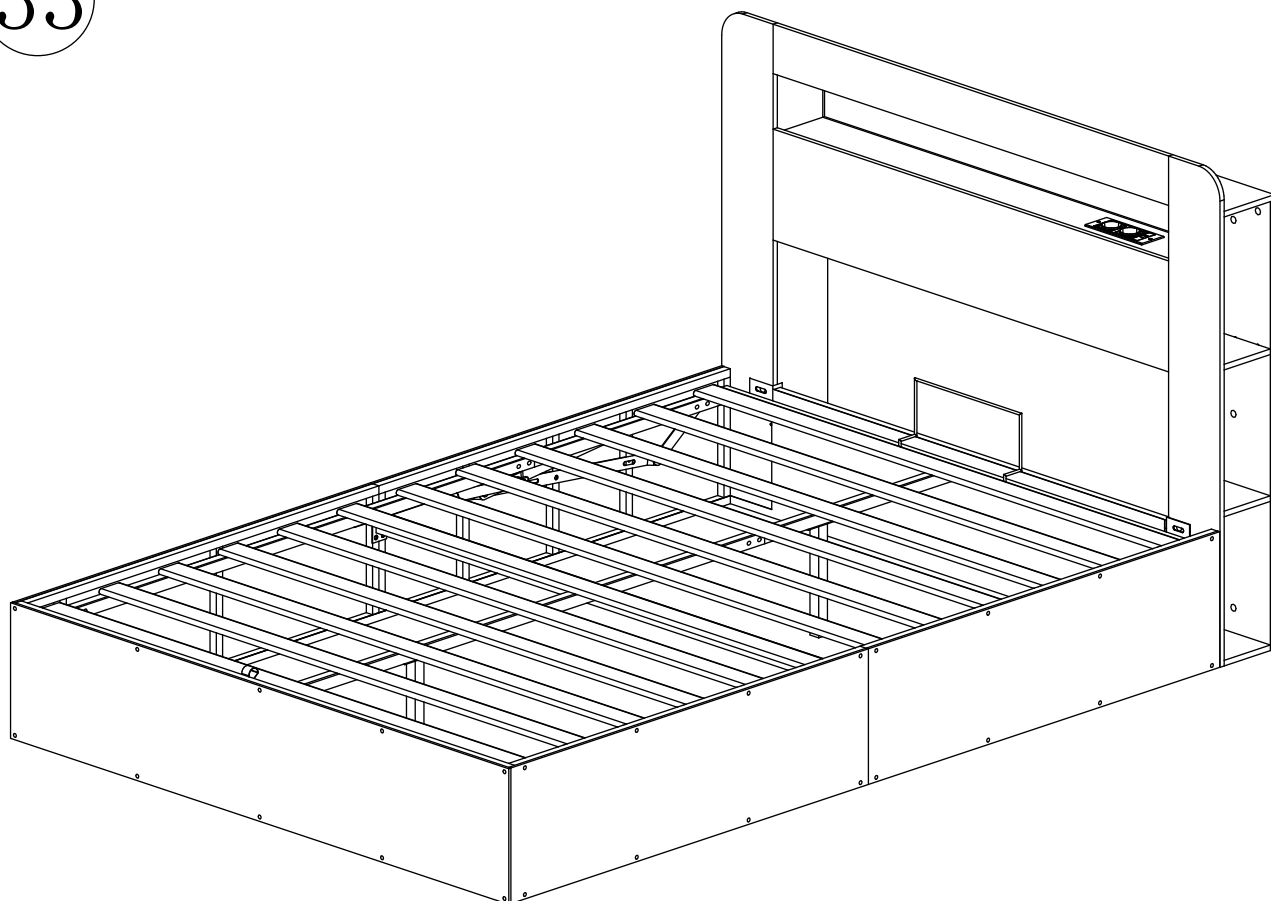

(Deutsch) : "Sie können den QR-Code scannen, um die App herunterzuladen und die LED-Leiste per Smartphone zu steuern."

(English) : "You can scan the QR code to download the app and control the LED light strip via your smartphone."

(Français) : "Vous pouvez scanner le code QR pour télécharger l'application et contrôler la bande lumineuse LED via votre téléphone portable."

(Español) : "Puede escanear el código QR para descargar la aplicación y controlar la tira de luces LED mediante su teléfono móvil."

(Italiano) : "Puoi scansionare il codice QR per scaricare l'app e controllare la striscia LED tramite il tuo smartphone."

LotusLantern APP Manual

1. Software Overview

1.1 Overview

LotusLantern is a mobile APP to control LED strip by both Apple and Android phones.

The traditional control ways like infrared, 433MHz, 2.4GHz and others old wired ways will be replaced by mobile phone control way with convenient, powerful and scalable features.

Through this mobile APP, you can not only control the color, brightness and color temperature of the LED strips but also set up all kinds of fancy flash mode; Also this APP can change the light of the LED strip according to the rhythm of the music. This APP can set and control several LED strips through Bluetooth and the operation is very simple, easy to learn and easy to use.

1.2 Features

- Adjust color LED strips with 60,000 colors to change color and brightness and adjust monochrome LED strips to change brightness and color temperature
- Play music or turn on a sound playback device, you can let the light change the color and brightness with the rhythm of music, the music rhythm beautiful
- Inside multiple setting mode for color change and control LED strips without mobile
- Long distance control with omni-directional antenna, and many-to-many group control mode
- Once the connection is successful, connect automatically next time

1.3 Performance

LotusLantern APP is easy for use as well as great compatible for all kinds of smart phones; After the actual test of hundreds of mobile phones verification, the compatibility is above 95% of mobile phones in the market. APP is small and convenient, it consumes less system resources, so the requirements of the mobile configuration are low. Control delay is small, the operation feel good, light control is smooth with people's visual sense.

2. Operating Environment

This APP program requires phones of system above Android 4.3 and iOS 8.0. Mobile phone configuration is not limited.

3. Instructions

Note: Android version and iOS version download and use the same method, here in the Android version as an example.

3.1 APP Download

- Scan the QR code

iOS and Android systems can download the "LotusLantern" APP by scanning the QR code. Open the browser or other tools with "Scan QR code" function, scan the "LotusLantern" QR code as below:



3.2 App Operation

- (1) Click on the LotusLantern APP icon, enter the APP page:

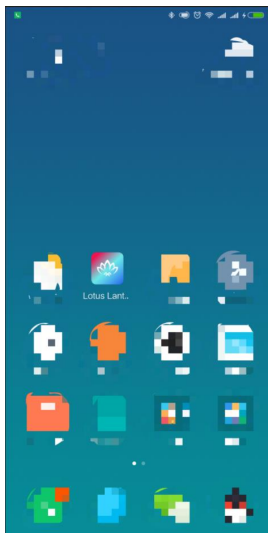

- (2) After entering the APP interface, if Bluetooth is not enabled, "an application wants to enable the Bluetooth function of this device." Click [Allow]

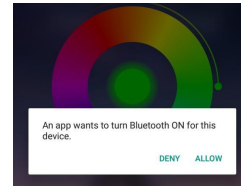

- (3) switch to color and brightness interface:



- (4) click to show the lamp list, view lamp list:

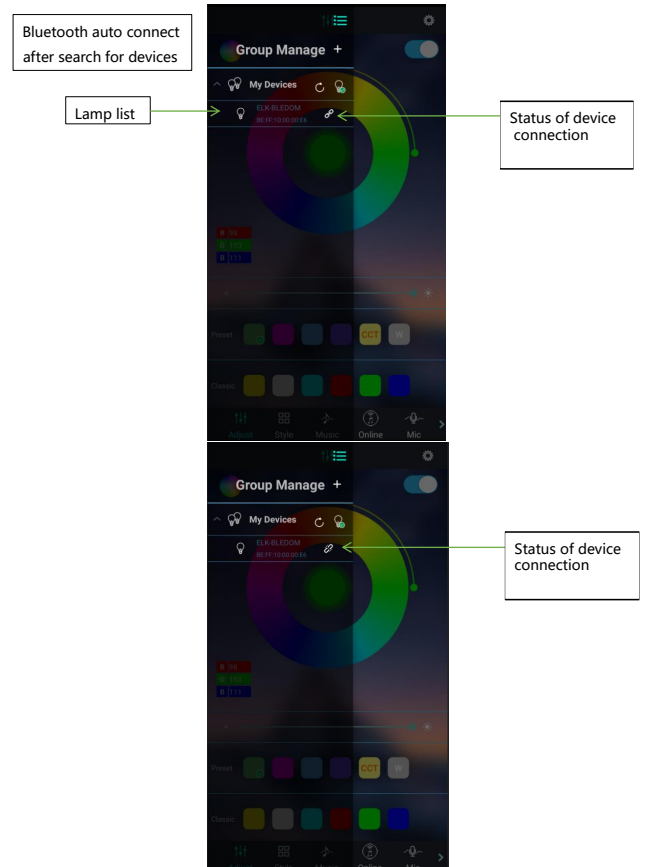

(5) Click to RGB manual adjustment view:

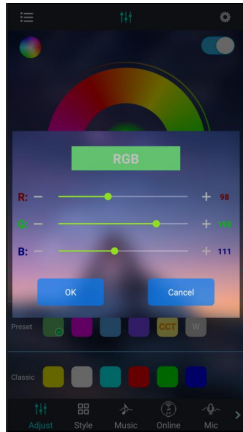

(6) switch to the mode interface:

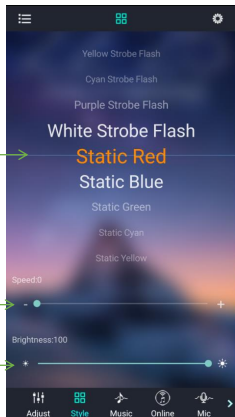

Scroll the selection mode

Adjust seed

Adjust luminance

(7) switch to the music rhythm interface:

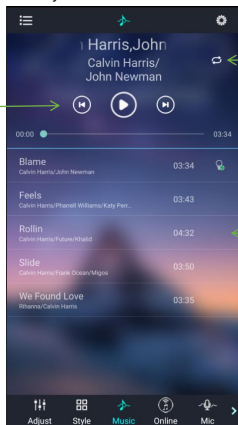

Previous song, Pause/Play, Next song

Recycle mode

Music List

(8) Switch to the online music interface:

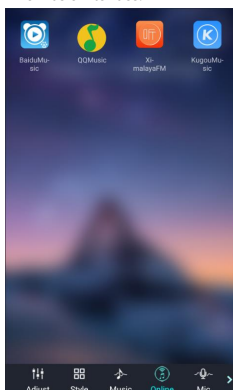

(9) Switch to the microphone rhythm interface:

Music rhythm through cell phone microphone

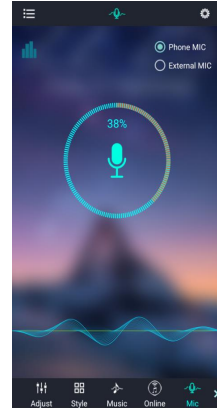

Switch phone microphone and external microphone

Music rhythm through the microphone on the product

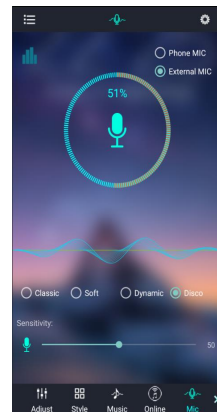

Switch phone microphone and external microphone

4-style rhythm

Change the sensitivity of MIC to match the sound

(10) Switch to the schedule interface:

Set the time of Light-On

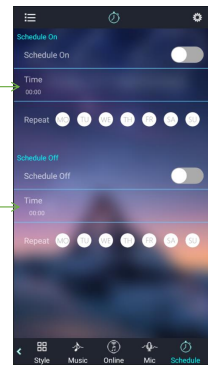

Enable or disable the Light-On function

Repeat setting
No selection for once Light-

Enable or disable the Light-Off function

Repeat setting
No selection for once Light-Off Light-On function

Set the time of Light-Off

(11) Switch to the modify pin sequence interface:

Click to save the new assignment

Change the real color of this line

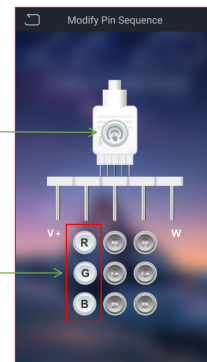

Shenzhen Promise Test Technology Co.,Ltd.
103, Building 1, Yibaolai Industrial City, Qiaotou Community, Fuhai
Street, Baoan District, Shenzhen, Guangdong, China.



Certificate of Compliance

Certificate No.: PRMS2412153SC

Applicant : Shenzhen xu xing technology co., LTD
Address : Floor 3, building C, Huaze hi tech Industrial Park, Shiyao street, Bao'an District, Shenzhen
Manufacturer : Shenzhen xu xing technology co., LTD
Address : Floor 3, building C, Huaze hi tech Industrial Park, Shiyao street, Bao'an District, Shenzhen
Product : Colorful light strip
Trade Mark : /
Model(s) : XX5050RGB-60D
XX5050RGB-30D, XX5050RGB-72D, XX5050RGB-96D, XX5050RGB-120D,
XX2835-120D, XX2835-60D, XX2835-150D, XX2835-240D, XX2835-W,
Y-120D, XX2835-W, Y-60D, XX2025-120D
Test Standard : IEC 62321-5:2013 & IEC 62321-4:2013+A1:2017 &
IEC 62321-7-2:2017 & IEC 62321-6:2015 & IEC 62321-8:2017 & IEC
62321-3-1:2013 & IEC 62321-7-1:2015

This certificate of compliance is based on a test procedure or an evaluation of the above-mentioned product. This is to certify that the above-mentioned product is in compliance with the RoHS Directive 2011/65/EU Annex II amending Annex (EU)2015/863. It is only valid in connection with the test report number: PRMS2412153SR.

After preparation of the necessary technical documentation according the requirement of EN IEC 63000:2018 as well as the verification of conformity the CE marking as shown below can be affixed on the equipment.



This Certificate of Conformity is based on single evaluation of the submitted sample(s) of the above mentioned product. It does not imply an assessment of the whole product and relevant . Directives have to be observed.

+86-0755-23319501 info@pnms-test.com www.pnms-test.com





This certificate is responsible for testing sample only.
Please refer to this corresponding test report to get testing process and data.

CERTIFICATE

ATTESTATION Certificate of Compliance

Technical file of the company mentioned below has been inspected and audit has been completed successfully

The EMC Directive 2014/30/EU has been taken as references for these processes.

Certificate's Holder : Shenzhen xu xing technology co., LTD
 Address : Floor 3, building C, Huaze hi tech Industrial Park, Shiyan street, Bao'an District, Shenzhen
 Manufacturer : Shenzhen xu xing technology co., LTD
 Address : Floor 3, building C, Huaze hi tech Industrial Park, Shiyan street, Bao'an District, Shenzhen
 Product Name : XX LED RGB STRIP
 Product Model (S) : XX5050RGB-60D, 5V-5050RGB-30D, 5V-5050RGB-60D, 12V-5050RGB-60D, 12V-5050RGB-30D, DY05RGB122, DY05RGB140, DY05RGB88
 Trade Mark : N/A
 Related Directive : 2014/30/EU
 EN IEC 55015:2019 + A11:2020
 Related Standards : EN IEC 61000-3-2:2019 + A1:2021 + A2:2024
 EN 61000-3-3:2013 + A1:2019 + A2:2021
 EN IEC 61547:2023
 Certificate Number : HK2509024994E
 Report No. : HK2509024994-1ER
 Registration Date : Oct. 21, 2025

Jason
 Certification Manager



The information of the certificate can be checked through <https://www.huak.com>. The CE mark which is shown on the certificate can only be used under the conditions that the products complete with all of the relevant Directives of CE Declaration of Conformity. The Manufacturer should be responsible for the internal production control so that the products complied with the essential requirements of the above mentioned Directive(s). Certificate holder must notify all changes to the original certification laboratory of HUAKE.

Shenzhen HUAKE Testing Technology Co., Ltd.

Addr.:1-2/F, B2 Building, Junfeng Zhongcheng Zhizao Innovation Park, Heping Community, Fuhai Street, Bao'an District, Shenzhen, China

Tel.:+86-0755-2302 9901

E-mail:info@huak.com

Website:https://www.huak.com



This certificate is responsible for testing sample only.
Please refer to this corresponding test report to get testing process and data.

CERTIFICATE

ATTESTATION Certificate of Compliance

Technical file of the company mentioned below has been inspected and audit has been completed successfully

The RED Directive 2014/53/EU has been taken as references for these processes.

Certificate's Holder : Shenzhen xu xing technology co., LTD
 Address : Floor 3, building C, Huaze hi tech Industrial Park, Shiyan street, Bao'an District, Shenzhen
 Manufacturer : Shenzhen xu xing technology co., LTD
 Address : Floor 3, building C, Huaze hi tech Industrial Park, Shiyan street, Bao'an District, Shenzhen
 Product Name : XX LED RGB STRIP
 Product Model (S) : XX5050RGB-60D, 5V-5050RGB-30D, 5V-5050RGB-60D, 12V-5050RGB-60D, 12V-5050RGB-30D, DY05RGB122, DY05RGB140, DY05RGB88
 Trade Mark : N/A
 Related Directive : 2014/53/EU
 Article 3.1a) : EN IEC 62368-1:2024 + A11:2024
 EN 62479:2010
 EN 50663:2017
 Related Standards : Article 3.1b) : ETSI EN 301 489-1 V2.2.3 (2019-11)
 ETSI EN 301 489-3 V2.3.2 (2023-01)
 EN IEC 61000-3-2:2019 + A1:2021 + A2:2024
 EN 61000-3-3:2013 + A1:2019 + A2:2021
 Article 3.2) : ETSI EN 300 220-1 V3.1.1 (2017-02)
 ETSI EN 300 220-2 V3.3.1 (2025-03)
 Certificate Number : HK2509024992E
 Report No. : HK2509024992-1SR/-2EH/-1ER/-2ER
 Registration Date : Oct. 21, 2025

Jason



Certification Manager



The information of the certificate can be checked through <https://www.huak.com>. The CE mark which is shown on the certificate can only be used under the conditions that the products complete with all of the relevant Directives of CE Declaration of Conformity. The Manufacturer should be responsible for the internal production control so that the products complied with the essential requirements of the above mentioned Directive(s). Certificate holder must notify all changes to the original certification laboratory of HUAKE.

Shenzhen HUAKE Testing Technology Co., Ltd.

Add.:1-2/F, B2 Building, Junfeng Zhongcheng Zhizao Innovation Park, Heping Community, Fuhai Street, Bao'an District, Shenzhen, China

Tel.:+86-0755-2302 9901

E-mail:info@huak.com

Website:https://www.huak.com

Certificate of Conformity

No.: LP24030331C02-02

The following products have been tested by us with the listed standards and found in compliance with the council EMC directive 2014/30/EU. It is demonstrative for the compliance with this EMC Directive.

Applicant : Dongguan Nanfan Electronic Technology Co., Ltd.
Address : Room 202,NO.19, Wanbu Road, Changping Town 523586
Dongguan Guangdong, China
Product : Furniture Power Distribution Unit
Model No. : NF-EUxAA-y, NF-EUxAC-y, NF-EUxAAC-y, NF-EUxACC-y
("x", "y" are variables, see page 4 of the test report for details.)
Trade Mark: : NANFAN
Test Standards : EN 55032:2015+A11:2020+A1:2020
EN 55035:2017+A11:2020
EN IEC 61000-3-2:2019+A1:2021
EN 61000-3-3:2013+A1:2019+A2:2021



Manager: Frank Shen
Date: July 15, 2024

Dongguan Lepont Testing Service Co., Ltd.

Tel.:86-769-83086888 Fax.:86-769-83096886

Room 102, Building 11, No.7, Houjie Science And Technology Avenue, Houjie, Dongguan,
Guangdong, China

The statement is based on a single evaluation of one sample of above mentioned products. It does not imply an assessment of the whole production and does not permit the use of the test lab's logo.



Certificate of Conformity

No.:CCI240700866EN-2CER

Reference Report No. : CCI240700866EN-2

Applicant : Dongguan Nanfan Electronic Technology Co., Ltd.
Address : Room 202,NO.19, Wanbu Road, Changping Town 523586
Dongguan Guangdong, China

Sample Name : Furniture Power Distribution Unit
NF01-EU01, NF02-EU01, NF03-EU01, NF04-EU01, NF01-EU02,
Model/Item No. : NF02-EU02,NF03-EU02, NF04-EU02, NF01-EU03, NF02-EU03,
NF02-EU03 ,NF04-EU03,NF01-EU04, NF02-EU04, NF03-EU04,
NF04-EU04

Test Standards : IEC 62321-4: 2013+A1:2017 IEC 62321-7-1:2015
IEC 62321-5: 2013 IEC 62321-7-2:2017
IEC 62321-6:2015 IEC 62321-8:2017

The submitted sample(s) stated as above has(have) been tested by us with the listed standards and found in conformity with the requirements stated in Directive 2011/65/EU of the European Parliament and of the Council with regard to the restriction of the use of certain hazardous substances in electrical and electronic equipment and its subsequent amendments as well as Commission Delegated Directive (EU) 2015/863. It is possible to use CE marking on the product to demonstrate the conformity with this Directive.

This certification is part of the full test report(s) and should be read in conjunction with it. The certificate is based on a single evaluation of one sample of above-mentioned products. It does not imply an assessment of the whole production. Other CE marking directives may be applied, they have not been considered during this RoHS conformity assessment.



Certificate of Conformity

No.: LP24030331C02-01R1

The following products have been tested by us with the listed standards and found in compliance with the council LVD directive 2014/35/EU. It is possible to use CE marking to demonstrative for the compliance with this LVD Directive.

Applicant : Dongguan Nanfan Electronic Technology Co ., Ltd.
Address : Room 202,NO.19, Wanbu Road, Changping Town 523586
Dongguan Guangdong, China
Product : Socket outlet (Furniture Power Distribution Unit)
Trade Mark : N/A
Model No. : NFxx-EUyy-16A/250Vz (x, y and z are variables , detail see test report)
Rated Input : 250V~, 50/60Hz, 16A
Rated Output: USB output ratings see test report

Test Standards : DIN VDE 0620-1:2021 Plug and socket-outlets for household and similar purposes-Part 1: General
EN IEC 62368-1:2020/Requirements on fixed socket-out
A11:2020 Audio/video, information and
communication technology equipment
Part 1: Safety requirements



Manager: Haylen Li
Date: 2025-05-26

Dongguan Lepont Testing Service Co., Ltd.

Tel.: 86-769-8308 6888 Fax.: 86-769-8309 6886
Room 102, Building 11, No. 7, Houjie Science And Technology
Avenue, Houjie, Dongguan, Guangdong, China

The statement is based on a single evaluation of one sample of above mentioned products. It does not imply an assessment of the whole production and does not permit the use of the test lab's logo.