

**SKU (N625P384195W) (N625P384196W) (N625P384197W)**

Product manual  
Gebeauchsanweisung  
Manuel du produit  
Manual del producto  
Manuale del prodotto

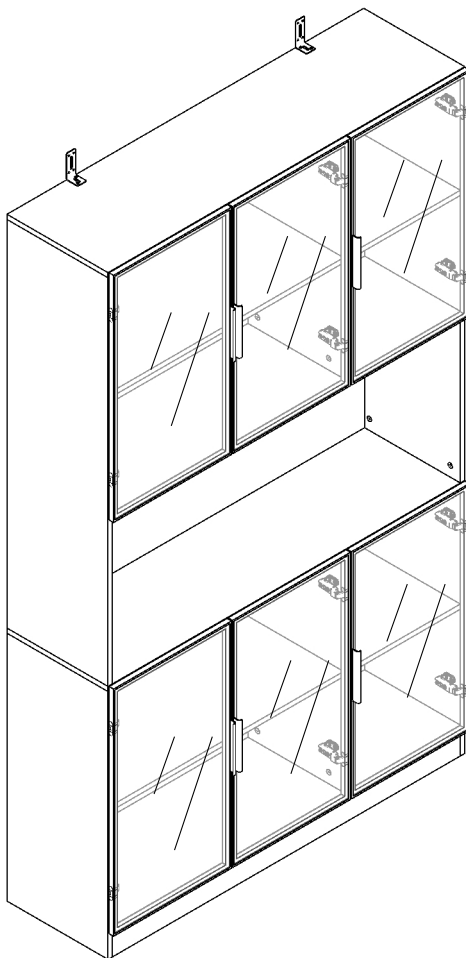

|                |  |
|----------------|--|
| Importeur      | Decobus Handel GmbH  |
| Adresse        | InnungsstraBe,21244 Buchholz,Deutschland   |
| Email/URL      | <a href="https://www.decobusgroup.de">https://www.decobusgroup.de</a>  |
| Hersteller     | Arising Asia Limited   |
| Adresse        | rooms 1318-19/F,Hollywood Plaza,610 Nathan Road,Mongkok,Kowloon,Hong Kong  |
| Email/URL      | <a href="mailto:young@civifurniture.net">young@civifurniture.net</a>   |
| Partienumm     | C776AAL20250919DS  |
| Hergestellt in | CHINA  |
| EC REP         | Decobus Handel GmbH<br>InnungsstraBe,21244 Buchholz,Deutschland<br><a href="https://www.decobusgroup.de">https://www.decobusgroup.de</a> |

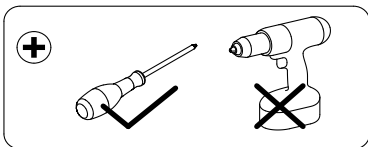
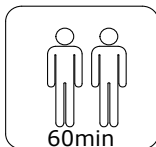

EN:Our product will be delivered to you in 3 packages. The delivery times of these 3 packages may differ, please be patient and thank you for your understanding  
FR:Notre produit vous sera livré en 3 colis.Les delais delivraison de ces 3 colis peuvent différer,soyezpatient et merci de votre compréhension.  
DE:User Produkt wird Ihnen in 3 Paketen geliefert. DieLieferzeiten dieser 3 Paketekonnenabweichen.bitte haben Sietwas Geduld und vielen Dank fur Ihr Verstandnis  
IT:I nostri prodotti vengono trasportati in tre pacchetti. I tempi di consegna dei tre pacchetti sono diversi: abbiate pazienza evi ringrazio per la vostra comprensione.  
ES:Nuestro producto se entrega en tres paquetes. El tiempo de entrega de estos tres paquetes es diferente. Por favor, seapaciente.Graciaspor su comprensión.



[DE]

**Warnung:** Lesen Sie diese Anleitung vor dem Zusammenbau bitte vollständig durch. Überprüfen Sie, ob Sie alle auf den Seiten aufgeführten Komponenten und Werkzeuge haben. Bewahren Sie die Anleitung zum späteren Nachschlagen auf. Teile des Zusammenbaus lassen sich mit 2 Personen leichter durchführen. Suchen Sie bei Bedarf professionelle Hilfe.

**Warnung:** Legen Sie alle Teile auf eine ebene Fläche. Legen Sie eine weiche Decke oder Ähnliches darunter, um sie vor Kratzern oder Flecken zu schützen. Vermeiden Sie es, Komponenten über den Boden zu ziehen oder zu schieben.

**Warnung:** Überprüfen Sie regelmäßig alle Beschläge und Befestigungen, um sicherzustellen, dass sie sicher sind und um Unfälle zu vermeiden. Wenn Teile fehlen, kaputt, beschädigt oder abgenutzt sind, verwenden Sie das Produkt nicht weiter, bis es mit vom Hersteller autorisierten Teilen repariert wurde.

**Warnung:** Lassen Sie Kinder nicht auf die Möbel klettern, da dies zum Umkippen und zu schweren Verletzungen führen kann. Bauen Sie die Möbel außerhalb der Reichweite von Kindern zusammen.

**Warnung:** Stellen Sie die Möbel nicht in die Nähe von Feuerquellen oder heißen Gegenständen, um Brandgefahr zu vermeiden.

**Warnung:** Reinigen Sie die Möbel mit einem feuchten Tuch oder Alkohol. Verwenden Sie keine Reinigungsmittel mit ätzenden Chemikalien.

**Warnung:** Dieses Produkt ist mit einer Kippschutzvorrichtung ausgestattet. Bitte installieren Sie diese Vorrichtung unbedingt, um unnötige Verletzungen durch Umkippen zu vermeiden.

[EN]

**Warning:** Please read these instructions fully before starting assembly. Check you have all the components and tools listed on pages. Keep the instructions for later reference. Parts of the assembly will be easier with 2 people. Seek professional assistance if necessary.

**Warning:** Please place all parts on a flat surface. Place a soft blanket or similar underneath to protect against scratches or stains. Avoid dragging or sliding components across the floor.

**Warning:** Regularly check all fittings and fastenings to ensure they are secure and to prevent accidents. If any parts are missing, broken, damaged, or worn, discontinue use of the product until repairs have been made using factory authorized parts.

**Warning:** Do not allow children to climb on the furniture as this may result in tipping and serious personal injury. Assemble the furniture away from the reach of children.

**Warning:** Do not place furniture close to fire sources or high-temperature objects to avoid the risk of fire. Do not place furniture in damp environments to prevent material damage.

**Warning:** Clean furniture with a damp cloth or alcohol, avoid using cleaning agents containing corrosive chemicals.

**Warning:** This product is equipped with an anti-tilt device. Please be sure to install this device to prevent unnecessary injuries caused by tipping.

[FR]

**Avertissement :** Veuillez lire attentivement ces instructions avant de commencer l'assemblage. Vérifiez que vous disposez de tous les composants et outils répertoriés sur les pages. Conservez les instructions pour référence ultérieure. Certaines parties de l'assemblage seront plus faciles à 2 personnes. Demandez l'aide d'un professionnel si nécessaire.

**Avertissement :** Veuillez placer toutes les pièces sur une surface plane. Placez une couverture douce ou similaire en dessous pour les protéger des rayures ou des taches. Évitez de faire glisser les composants sur le sol.

**Avertissement :** Vérifiez régulièrement tous les raccords et fixations pour vous assurer qu'ils sont bien fixés et pour éviter les accidents. Si des pièces manquent, sont cassées, endommagées ou usées, cessez d'utiliser le

produit jusqu'à ce que des réparations aient été effectuées à l'aide de pièces autorisées par l'usine.

**Avvertissement** : Ne laissez pas les enfants grimper sur les meubles car cela pourrait entraîner un basculement et des blessures graves. Assemblez les meubles hors de portée des enfants.

**Avvertissement** : Ne placez pas les meubles à proximité de sources de feu ou d'objets à haute température pour éviter tout risque d'incendie.

**Avvertissement** : Nettoyez les meubles avec un chiffon humide ou de l'alcool, évitez d'utiliser des produits de nettoyage contenant des produits chimiques corrosifs.

**Avvertissement** : Ce produit est équipé d'un dispositif anti-basculement. Assurez-vous d'installer ce dispositif pour éviter les blessures inutiles causées par un basculement.

[IT]

**Attenzione:** leggere attentamente queste istruzioni prima di iniziare il montaggio. Verificare di avere tutti i componenti e gli strumenti elencati nelle pagine. Conservare le istruzioni per riferimento futuro. Alcune parti del montaggio saranno più facili con 2 persone. Se necessario, chiedere assistenza professionale.

**Attenzione:** posizionare tutte le parti su una superficie piana. Posizionare una coperta morbida o simile sotto per proteggere da graffi o macchie. Evitare di trascinare o far scivolare i componenti sul pavimento.

**Attenzione:** controllare regolarmente tutti i raccordi e i dispositivi di fissaggio per assicurarsi che siano sicuri e per prevenire incidenti. Se alcune parti sono mancanti, rotte, danneggiate o usurate, interrompere l'uso del prodotto fino a quando non siano state eseguite le riparazioni utilizzando parti autorizzate dalla fabbrica.

**Attenzione:** non consentire ai bambini di arrampicarsi sui mobili poiché ciò potrebbe causare ribaltamenti e gravi lesioni personali. Montare i mobili lontano dalla portata dei bambini.

**Attenzione:** non posizionare i mobili vicino a fonti di fuoco o oggetti ad alta temperatura per evitare il rischio di incendio

**Attenzione:** pulire i mobili con un panno umido o alcol, evitare di utilizzare detergenti contenenti sostanze chimiche corrosive.

**Attenzione:** questo prodotto è dotato di un dispositivo antiribaltamento. Assicurarsi di installare questo dispositivo per prevenire lesioni inutili causate dal ribaltamento.

[ES]

**Advertencia:** Lea estas instrucciones completamente antes de comenzar el montaje. Compruebe que tiene todos los componentes y herramientas que se enumeran en las páginas. Conserve las instrucciones para consultarlas más adelante. El montaje de algunas partes será más sencillo con 2 personas. Busque ayuda profesional si es necesario.

**Advertencia:** Coloque todas las piezas sobre una superficie plana. Coloque una manta suave o algo similar debajo para protegerlas de rayones o manchas. Evite arrastrar o deslizar los componentes por el piso.

**Advertencia:** Verifique regularmente todos los accesorios y fijaciones para asegurarse de que estén seguros y evitar accidentes. Si falta alguna pieza, está rota, dañada o desgastada, deje de usar el producto hasta que se hayan realizado las reparaciones con piezas autorizadas de fábrica.

**Advertencia:** No permita que los niños se suban a los muebles, ya que esto puede provocar que se vuelquen y lesiones personales graves. Monte los muebles fuera del alcance de los niños.

**Advertencia:** No coloque los muebles cerca de fuentes de fuego u objetos de alta temperatura para evitar el riesgo de incendio.

**Advertencia:** Limpie los muebles con un paño húmedo o alcohol, evite usar agentes de limpieza que contengan químicos corrosivos.

**Advertencia:** Este producto está equipado con un dispositivo antivuelco. Asegúrese de instalar este dispositivo para evitar lesiones innecesarias causadas por vuelcos.

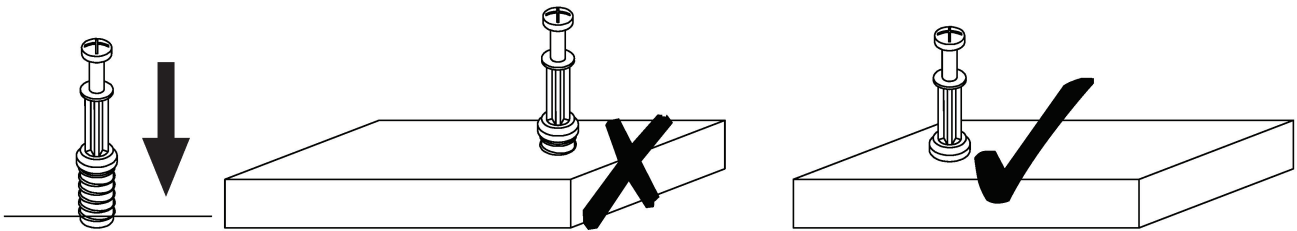

**EN\_QUICKFIT:** Tighten quickfit until shoulder is flush with panel. Do not overtighten or undertighten.

**FR\_RACCORD RAPIDE:** Faites serrer le raccord rapide jusqu'à ce que l'épaule soit parfaitement encastré dans le panneau. Il ne faut ni trop serrer ni insuffisamment serrer.

**ES\_QUICKFIT:** Apriete quickfit hasta que el hombro se descargue con el panel. NO lo sobreapriete ni lo apriete poco.

**DE\_QUICKFIT:** Ziehen Sie den Quickfit fest, bis die Schulter mit der Platte bündig ist. Bitte nicht zu fest oder zu schwach anziehen.

**IT\_MONTAGGIO RAPIDO:** Stringere il montaggio rapido fino a quando la spalla è a filo con il pannello, non stringere troppo o troppo poco.

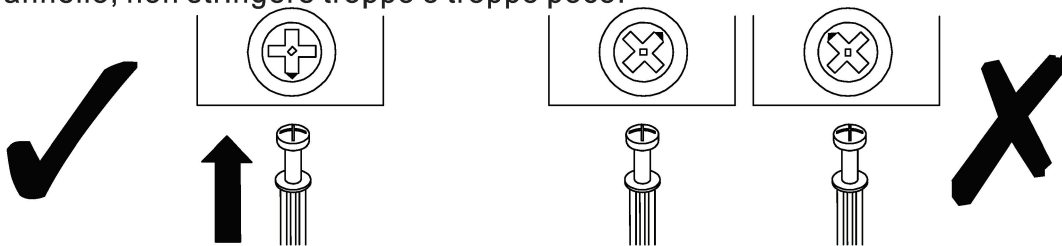

**EN\_CAM LOCK:** When fitting cam lock, ensure starting position is correct before you insert connecting quickfit.

**FR\_SERRURE BATTEUSE:** Avant d'insérer la serrure batteuse, veillez à la bonne orientation avant d'insérer le raccord rapide.

**ES\_CIERRE DE LA CÁMARA:** Cuando instale el cierre de la cámara, asegúrese de que la posición de inicio es correcta antes de que inserte el quickfit conector.

**DE\_CAM-LOCK:** Achten Sie bei der Montage des Cam-Locks auf die richtige Ausgangsposition, bevor Sie den Quickfit einsetzen.

**IT\_BLOCCAGGIO A CAMMA:** Quando si monta il bloccaggio a camma, assicurarsi che la posizione iniziale sia corretta prima di inserire il montaggio rapido di collegamento.

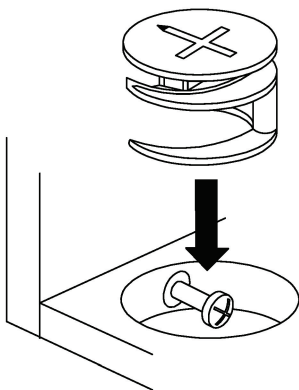

**EN\_Quickfit head** should be in the centre of the cam lock when the two panels are joined.

Cam lock should be inserted before quickfit.

**FR\_**Lorsque les deux panneaux sont assemblés, la tête du raccord rapide doit reposer au centre de la serrure batteuse.

Il faut insérer la serrure batteuse avant le raccord rapide.

**ES\_**El cabezal del quickfit debe estar en el centro del cierre de la cámara cuando se unan los dos paneles.

Se debe insertar el cierre de la cámara antes que el quickfit.

**DE\_**Der Quickfit-Kopf sollte sich in der Mitte des Cam-Locks befinden, wenn die beiden Platten zusammengefügt sind.

Der Cam-Lock sollte vor dem Quickfit eingesetzt werden.

**IT\_**La testa del montaggio rapido deve trovarsi al centro del bloccaggio a camma quando i due pannelli sono uniti.

Il Bloccaggio a Camma deve essere inserito prima del montaggio rapido.

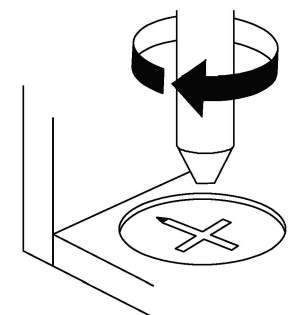

**EN\_**Turn cam lock clockwise to tighten.

**FR\_**Faites tourner la serrure batteuse dans le sens des aiguilles d'une montre pour la resserrer.

**ES\_**Gire el cierre de la cámara en sentido horario para apretarlo.

**DE\_**Drehen Sie den Cam-Lock im Uhrzeigersinn, um ihn festzuziehen.

**IT\_**Ruotare il bloccaggio a camma in senso orario per stringere.

**EN** It may be necessary to adjust the hinges so that the doors align. Use the instructions below as a guide.

**FR** Il est parfois nécessaire d'ajuster les charnières pour un meilleur alignement des portes. Servez-vous des instructions ci-dessous comme guide.

**ES** Puede que sea necesario ajustar los quicios de forma que se alineen las puertas. Use las instrucciones que aparecen debajo como guía.

**DE** Möglicherweise müssen Sie die Scharniere so einstellen, dass die Türen ausgerichtet sind. Verwenden Sie die nachstehenden Anweisungen als Leitfaden.

**IT** Potrebbe essere necessario regolare le cerniere in modo che le porte siano allineate. Per fare ciò attenersi alle istruzioni sottostanti.

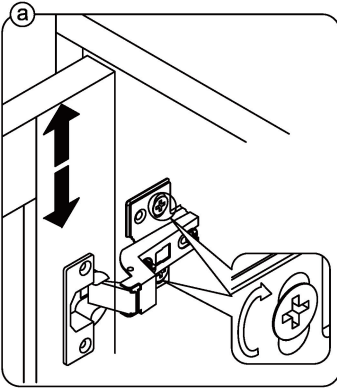

**EN** To adjust the door vertically loosen the screw as shown and move up and down as needed.

**FR** Si vous souhaitez régler la porte **verticalement**, desserrez la vis comme indiqué et déplacez la porte de haut en bas selon les besoins.

**ES** Para ajustar la puerta **verticalmente** afloje el tornillo tal y como se muestra y muévelo hacia arriba o hacia abajo según sea necesario.

**DE** Um die Tür **vertikal** auszurichten, lösen Sie die Schraube wie abgebildet und bewegen Sie sie nach Bedarf nach oben oder nach unten.

**IT** Per allineare la porta **verticalmente** allentare la vite come mostrato e spostarla in alto o in basso secondo necessità.

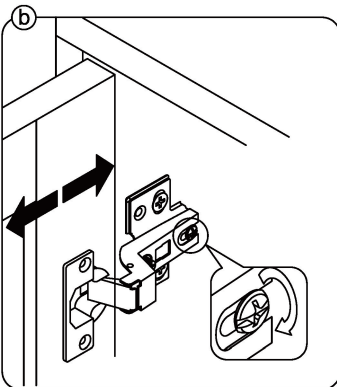

**EN** To adjust the gap from the door to the main frame turn the screw clockwise or anti-clockwise as needed.

**FR** Si vous souhaitez ajuster l'**écart** entre la porte et le cadre principal, tournez la vis dans le sens des aiguilles d'une montre ou dans le sens inverse, si nécessaire.

**ES** Para ajustar el **espacio** desde la puerta al marco principal, gire el tornillo en sentido horario o antihorario, según se necesite.

**DE** Um den **Abstand** von der Tür zum Hauptrahmen auszurichten, drehen Sie die Schraube je nach Bedarf im oder gegen den Uhrzeigersinn.

**IT** Per regolare lo **spazio** tra la porta e il telaio principale, avvitare o svitare la vite secondo necessità.

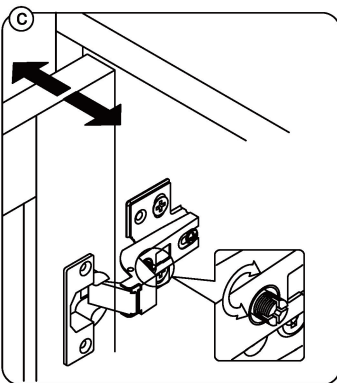

**EN** To adjust the door laterally adjust the screw as shown by turning clockwise or anti-clockwise.

**FR** Si vous souhaitez ajuster la porte **latéralement**, ajustez la vis comme indiqué en tournant dans le sens des aiguilles d'une montre ou dans le sens inverse des aiguilles d'une montre.

**ES** Para ajustar la puerta **lateralmente** ajuste el tornillo tal y como se muestra girándolo en sentido horario y antihorario.

**DE** Um die Tür **seitlich** auszurichten, stellen Sie bitte die Schraube wie abgebildet durch Drehen im oder gegen den Uhrzeigersinn ein.

**IT** Per allineare la porta **lateralmente** regolare la vite come mostrato, avvitarla o svitarla.

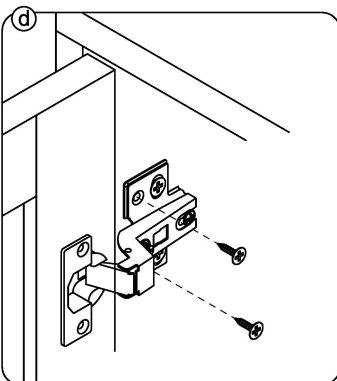

**EN** Please fix other screws

**FR** Merci de serrer les autres vis.

**ES** Fije los demás tornillos



**DE** Befestigen Sie bitte die anderen Schrauben





**IT** Fissare le altre viti

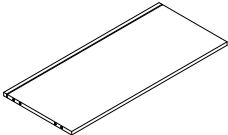
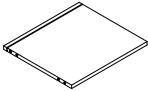

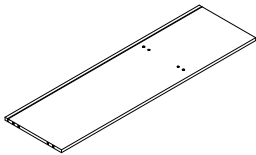
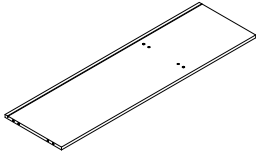
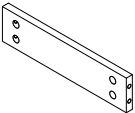
**BOX-1/3**  
(N625P384195W)

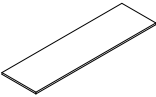

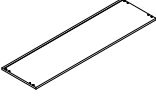
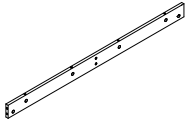
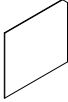
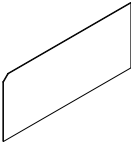
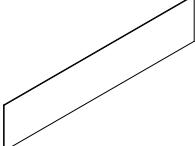

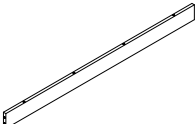
**BOX-2/3**  
(N625P384196W)

**BOX-3/3**  
(N625P384197W)

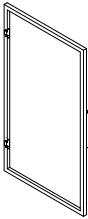
| NO. | PARTS   | QTY |
|-----|---|-----|
| ④   |    | 2   |
| ⑤   |    | 2   |
| ⑥   |   | 2   |
| ⑦   |  | 1   |
| ⑪   |  | 1   |
| ⑬   |  | 1   |

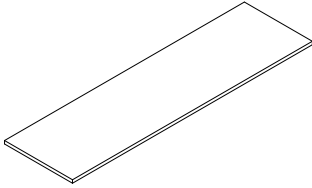
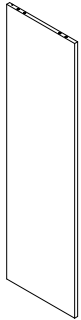

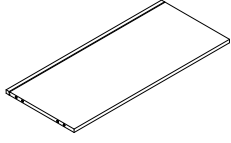
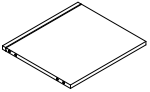
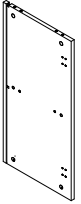
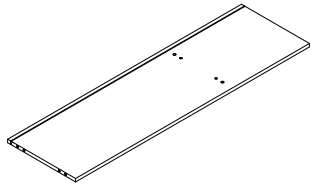
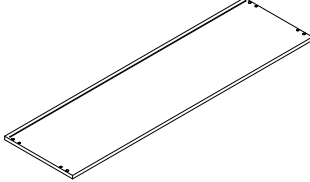
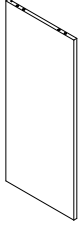
| NO. | PARTS   | QTY |
|-----|---|-----|
| ①   |    | 1   |
| ②   |    | 1   |
| ③   |    | 1   |
| ⑧   |   | 1   |
| ⑫   |  | 2   |
| ⑮   |  | 4   |
| ⑯   |  | 4   |
| ⑰   |  | 2   |
| ⑱   |  | 1   |
| ⑲   |  | 1   |

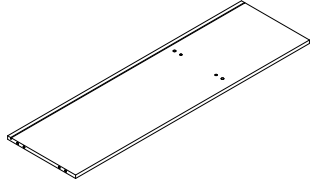
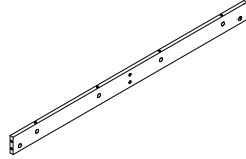
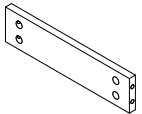
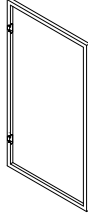
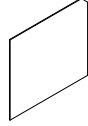
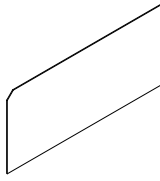
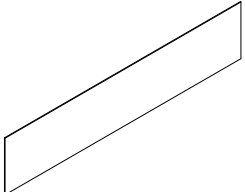
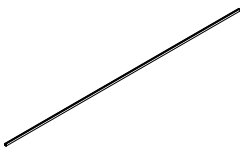
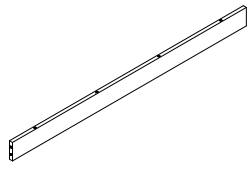
| NO. | PARTS   | QTY |
|-----|---|-----|
| ⑨   |    | 1   |
| ⑩   |    | 1   |
| ⑭   |  | 6   |

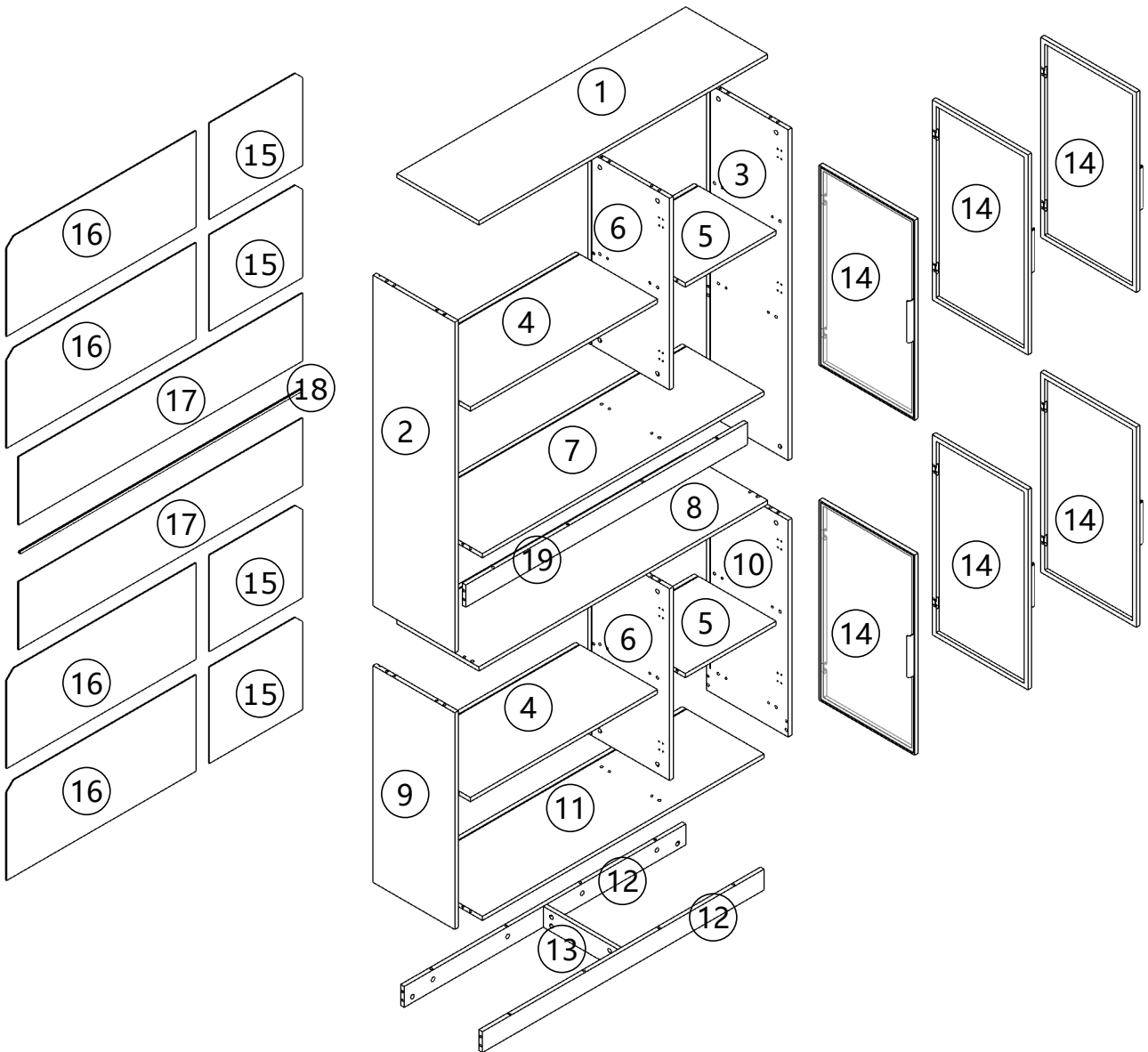
|   |   |  |   |
|---|---|--|---|
| ① X1<br>   | ② X1<br>   | ③ X1<br>   | ④ X2<br>   |
| ⑤ X2<br>   | ⑥ X2<br>   | ⑦ X1<br>   | ⑧ X1<br>   |
| ⑨ X1<br> | ⑩ X1<br> | ⑪ X1<br> | ⑫ X2<br> |
| ⑬ X1<br> | ⑭ X6<br> | ⑮ X4<br>  | ⑯ X4<br> |
| ⑰ X2<br> | ⑱ X1<br> | ⑲ X1<br> |   |

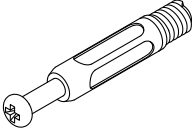
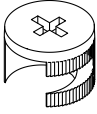
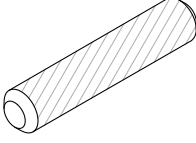

(N625P384195W)

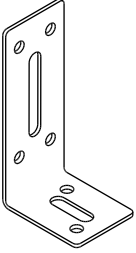
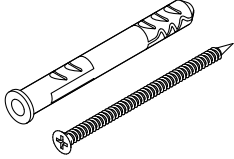
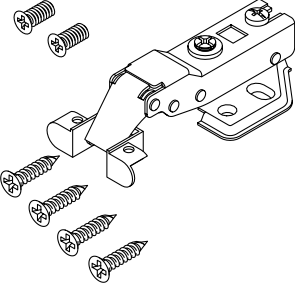
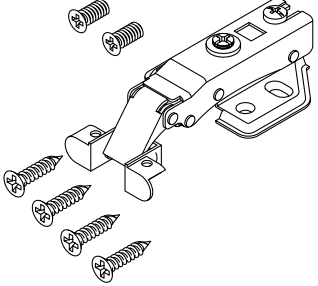
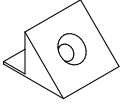
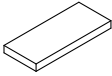
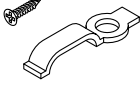
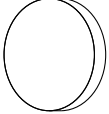
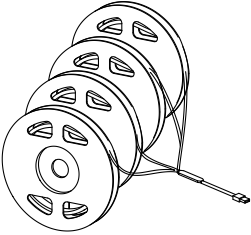
|   |   |  |  |
|---|---|--|--|
| <p><b>A X66</b></p>    | <p><b>B X66</b></p>              | <p><b>C X50</b></p>    | <p><b>D X39</b><br/>3.5*14mm</p>  |
| <p><b>E X2</b></p>     | <p><b>F X2</b><br/>4.5*80mm</p>  | <p><b>G X4</b></p>     | <p><b>H X8</b></p>                |
| <p><b>I X35</b></p>  | <p><b>J X6</b></p>             | <p><b>K X12</b></p>  | <p><b>L X24</b></p>             |
| <p><b>M X1</b></p>   |   |  |  |
|   |   |  |  |

01

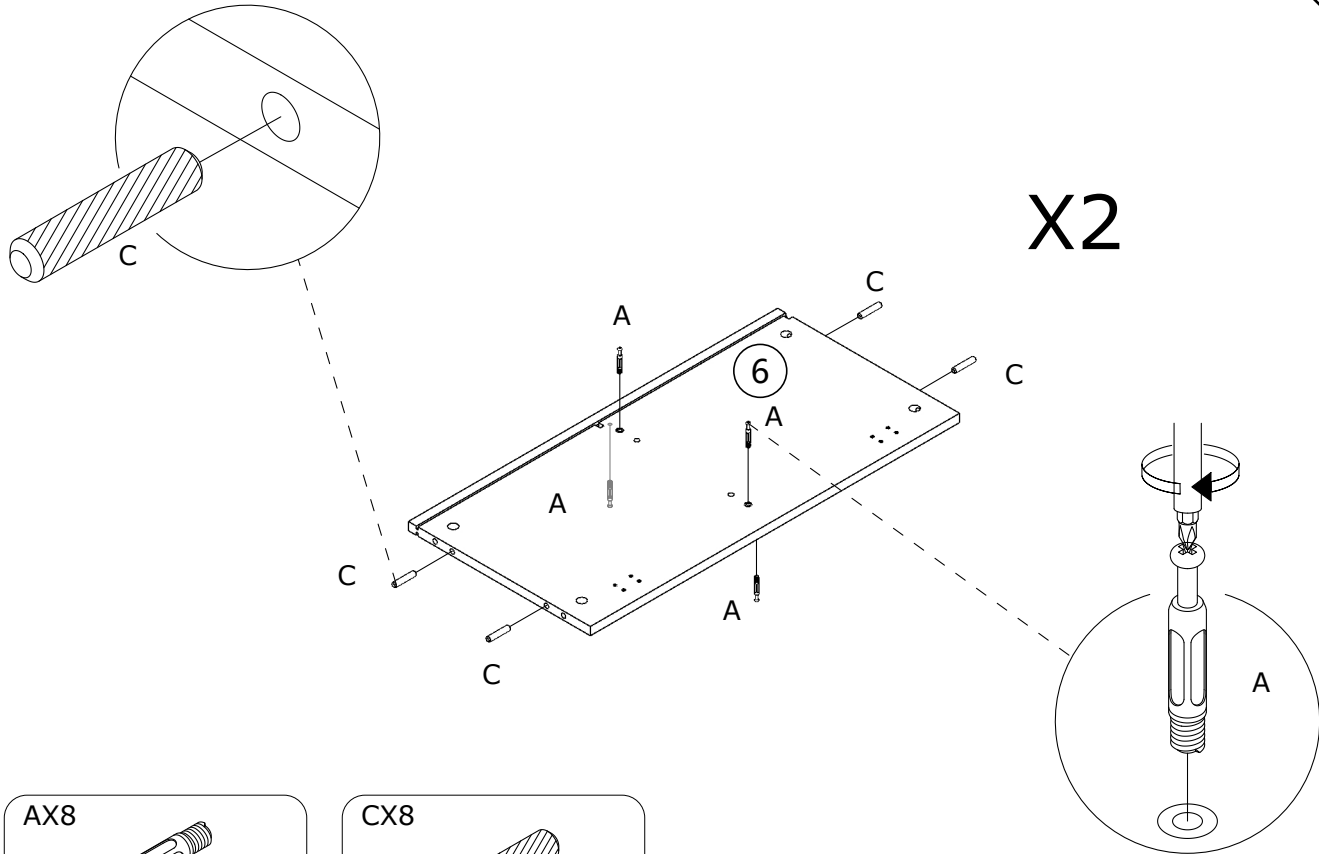

X2

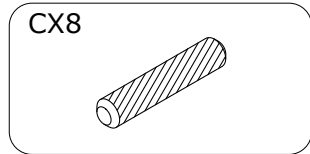
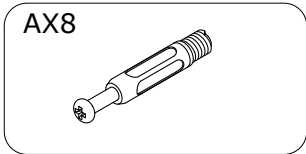

02

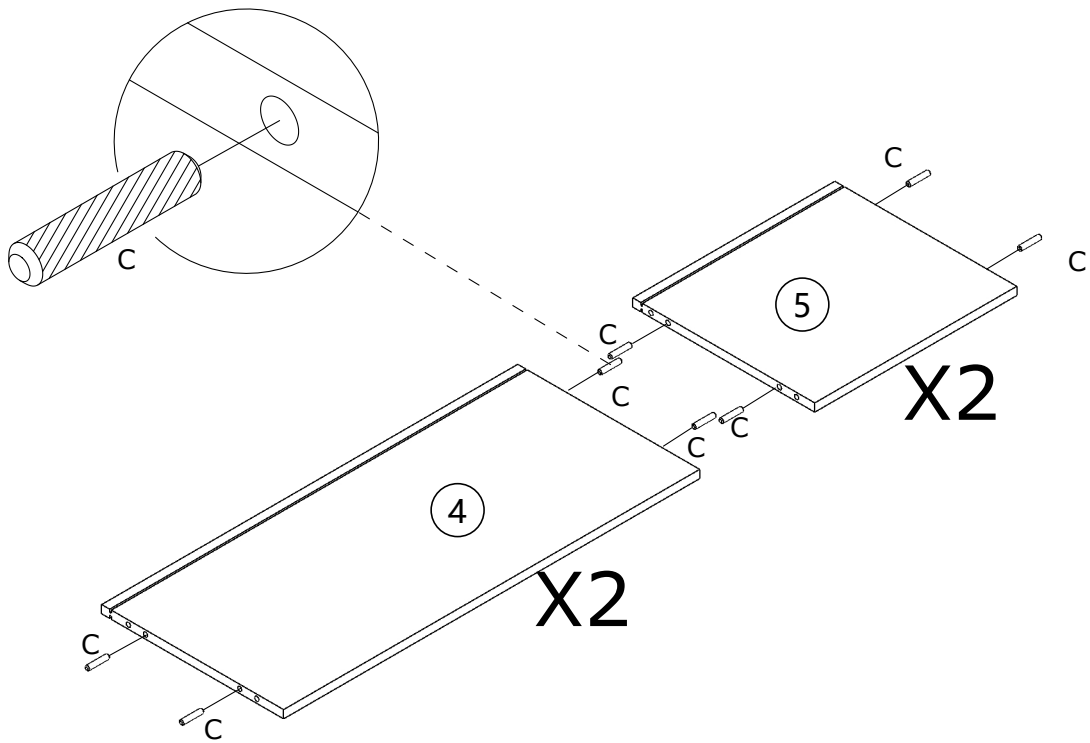

X2

X2

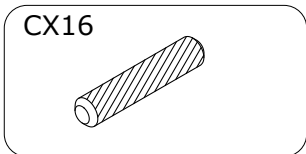

X2

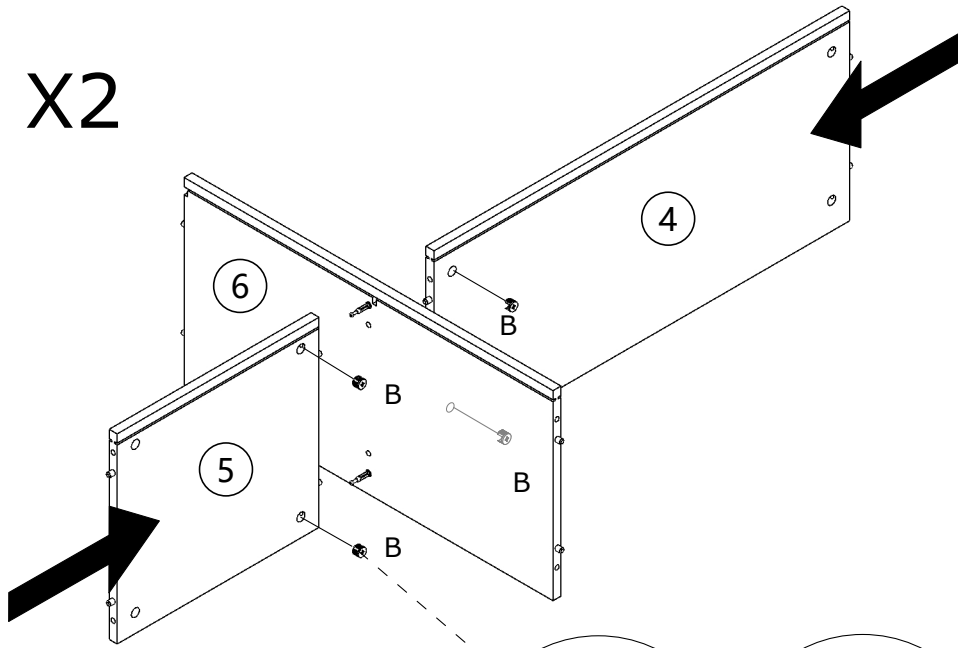

BX8

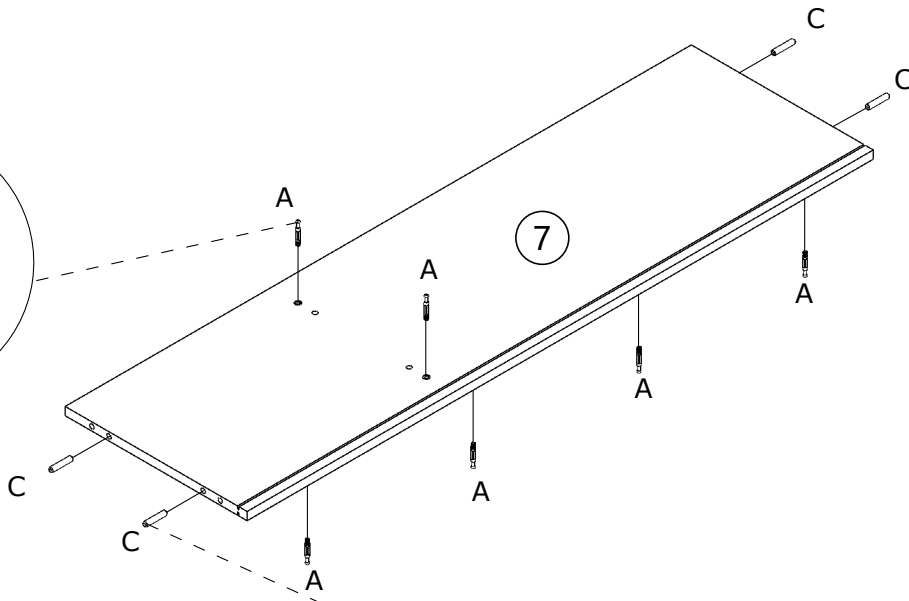
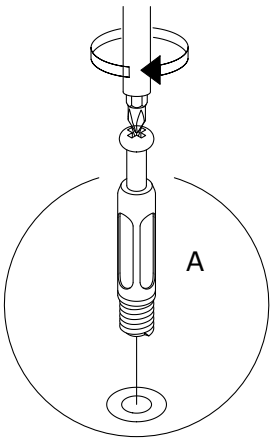
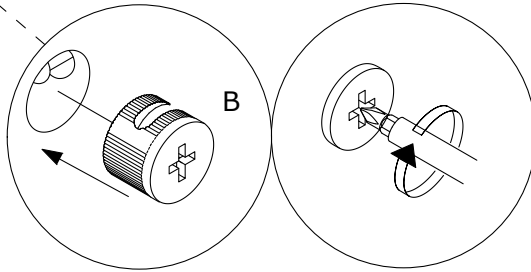

AX6

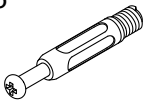

CX4

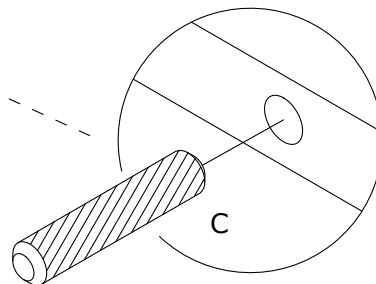
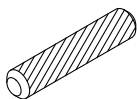

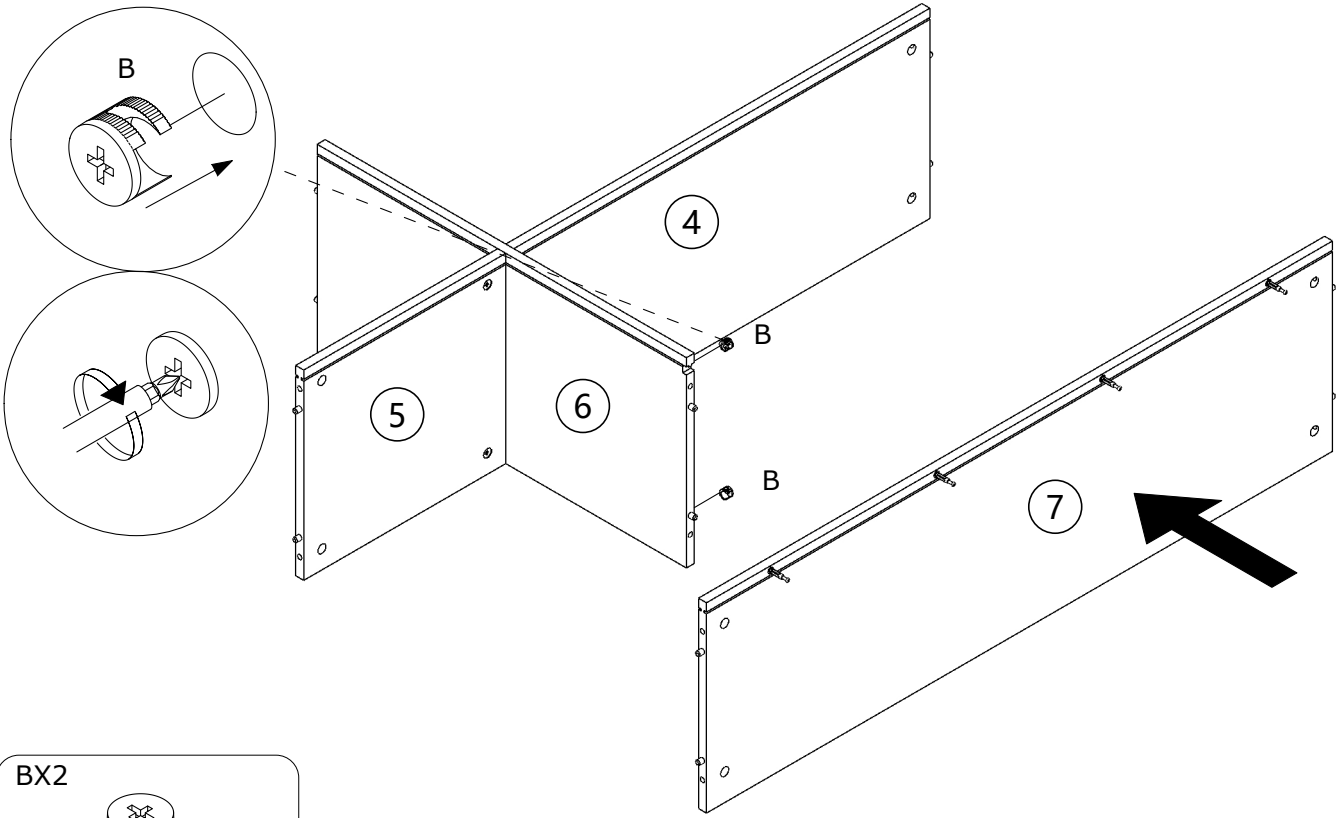

BX2

A legend box containing the text 'BX2' and a detailed drawing of a screw head with a cross-shaped recess.

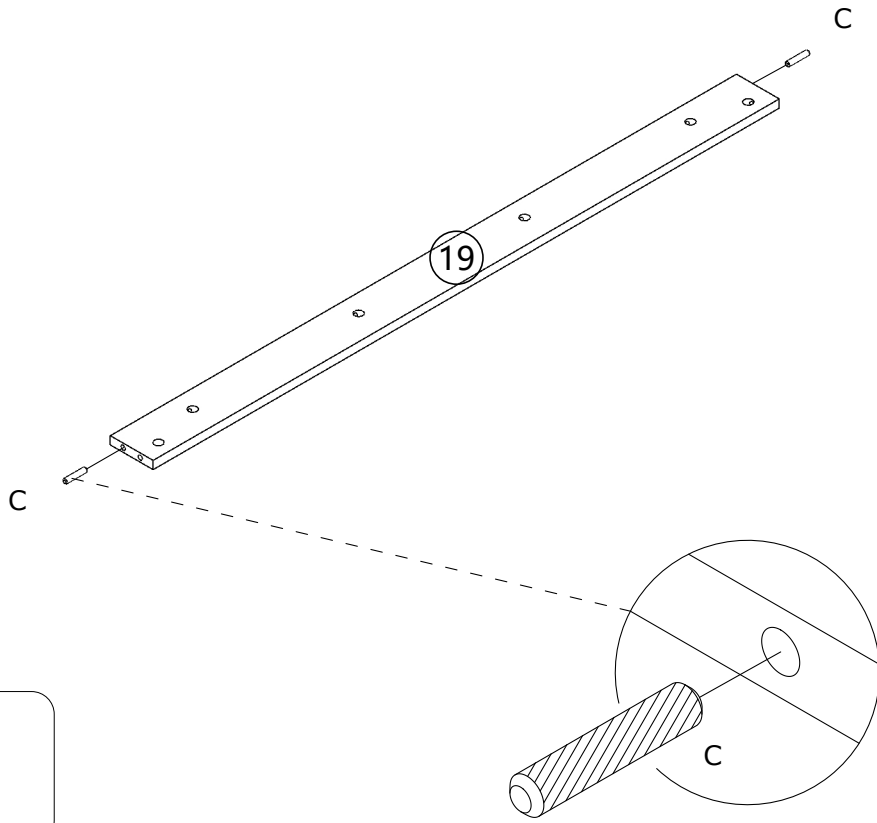

CX2

A legend box containing the text 'CX2' and a drawing of a cylindrical bar with a textured surface.

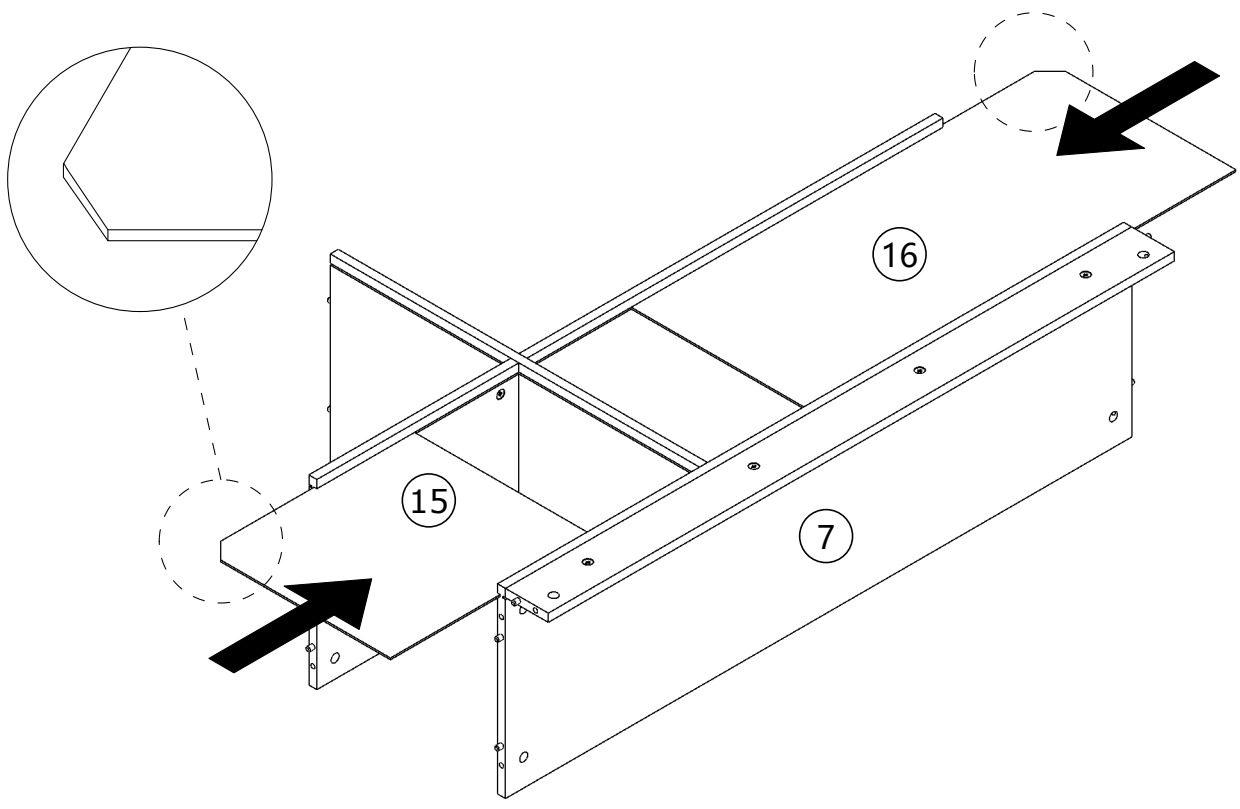
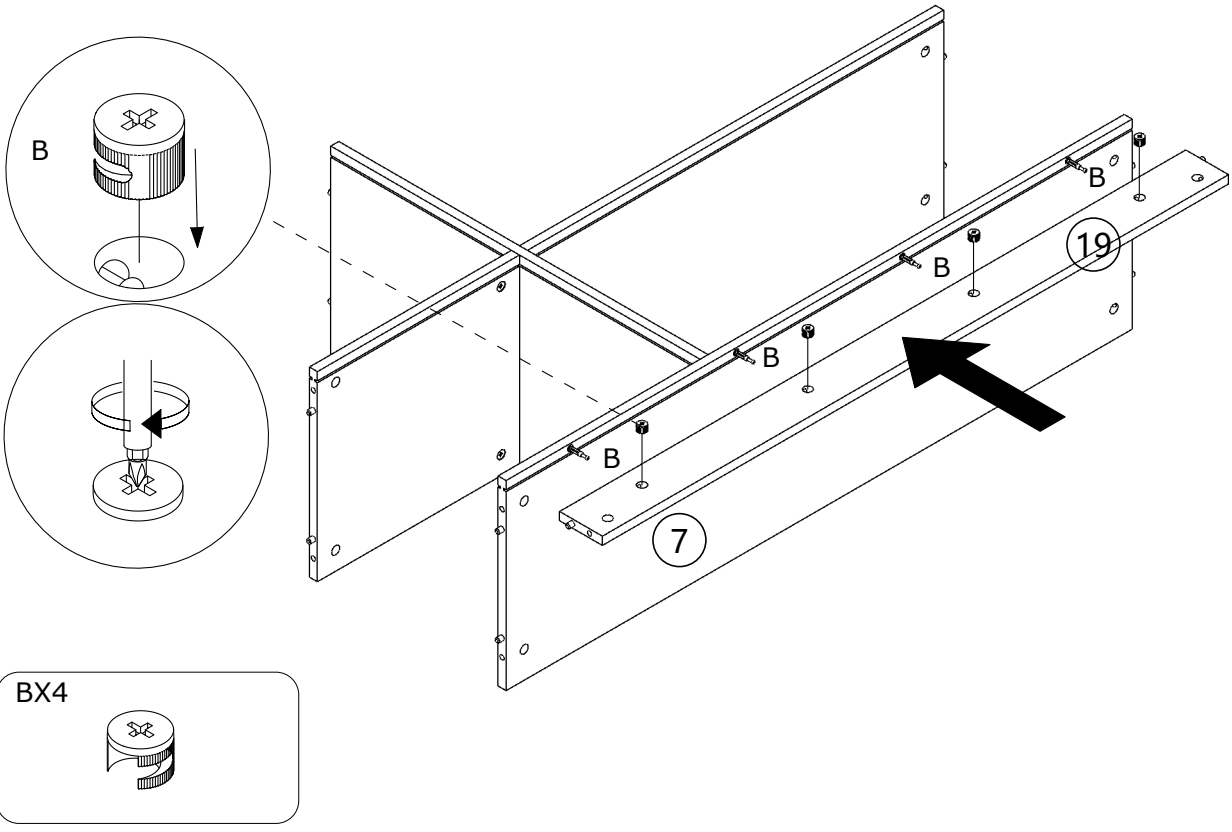

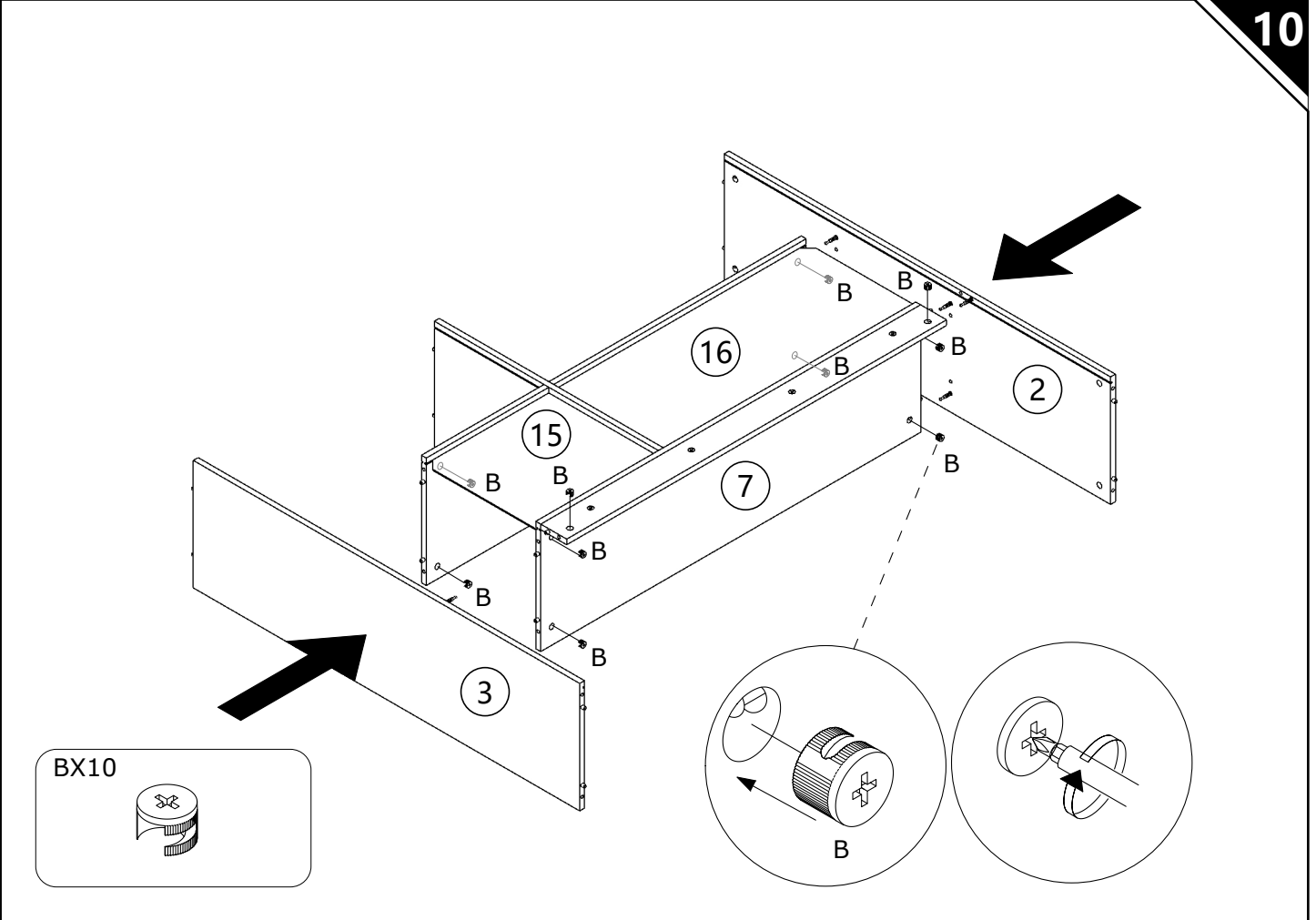
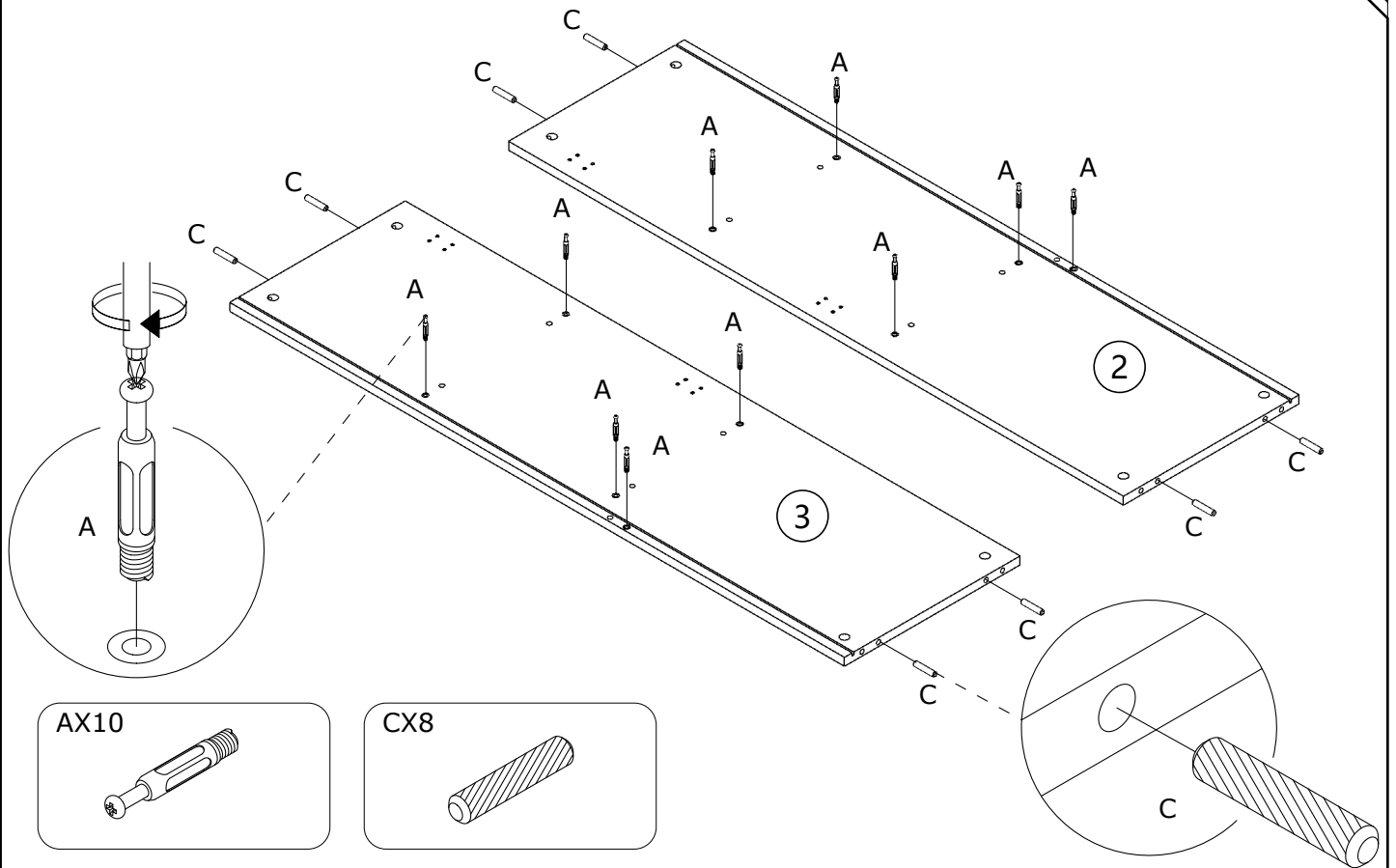

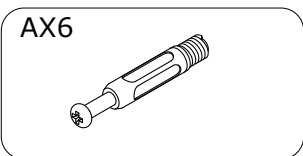
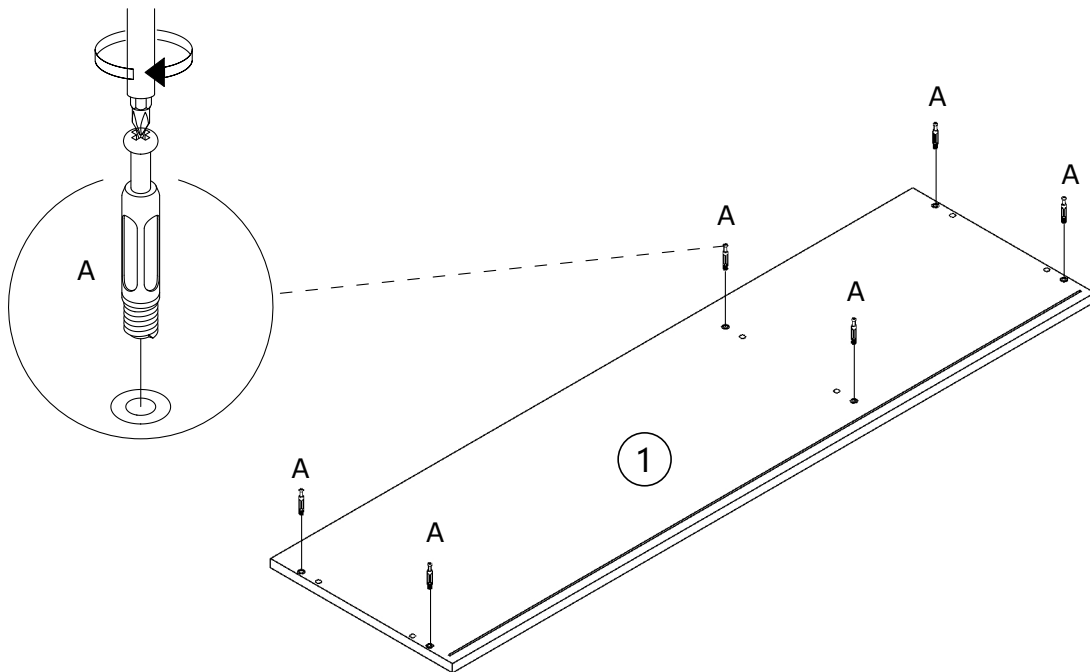
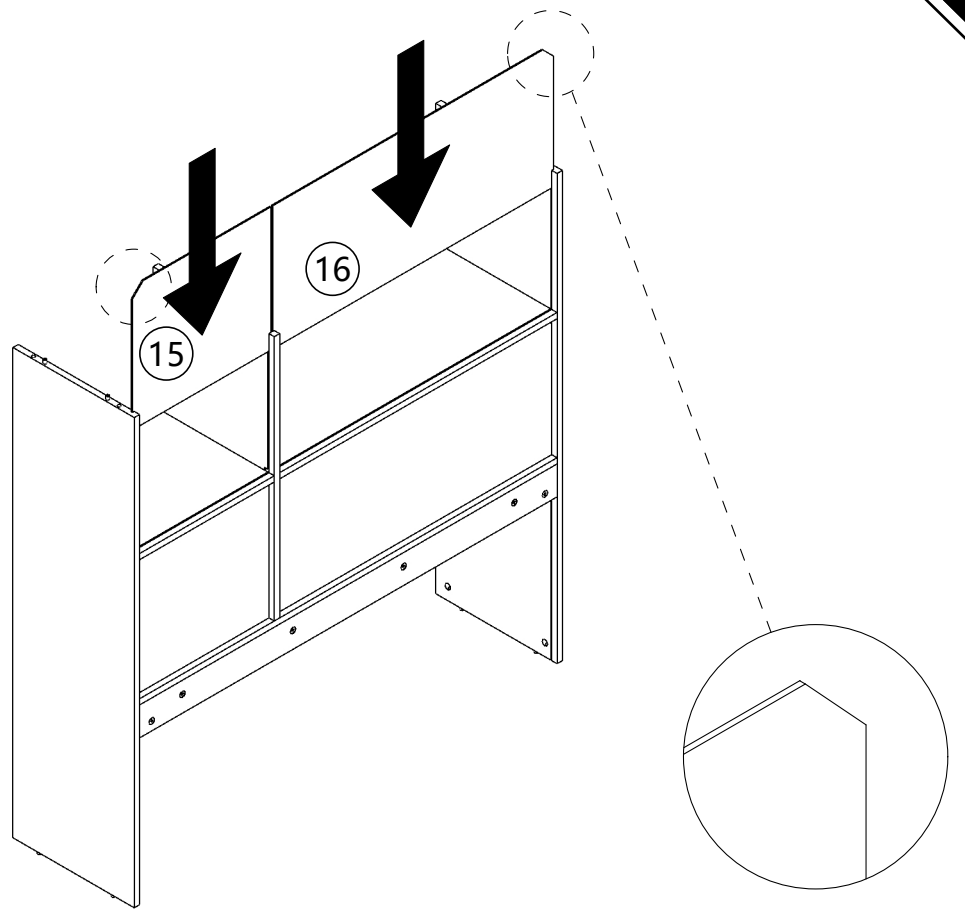

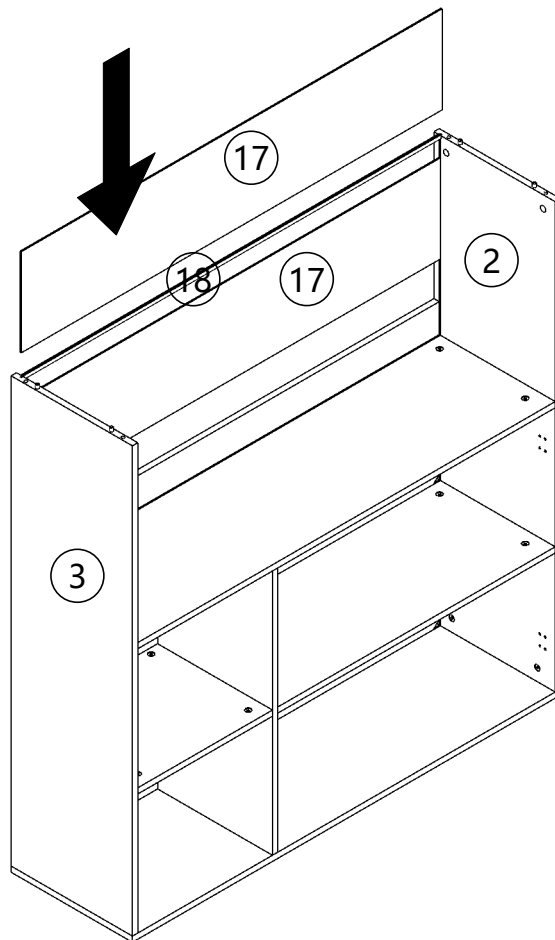
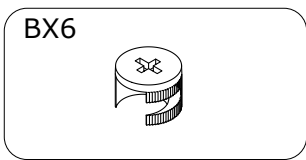
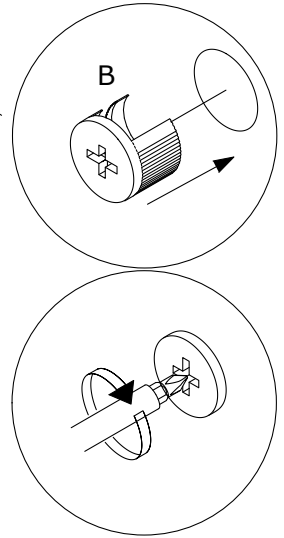
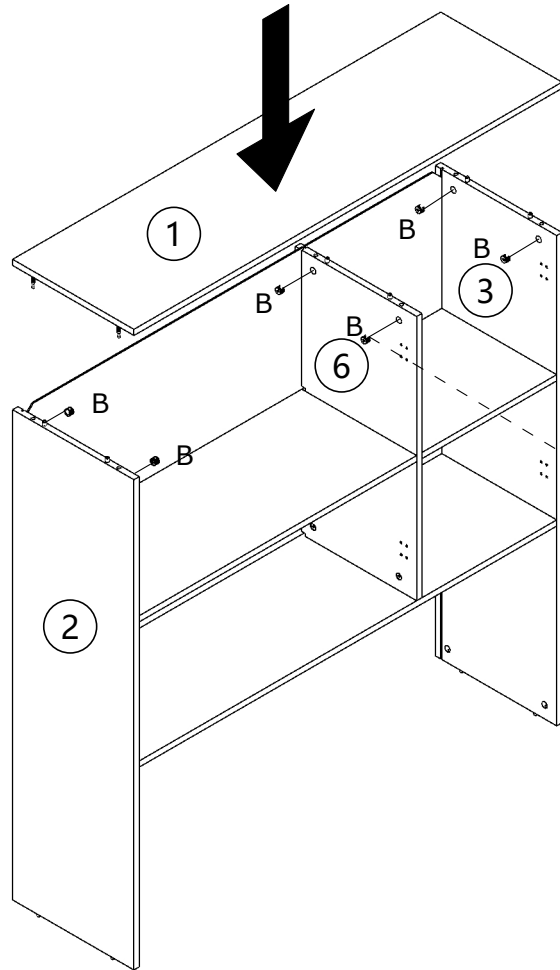

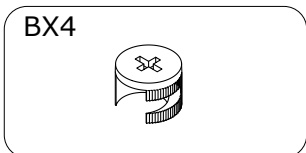
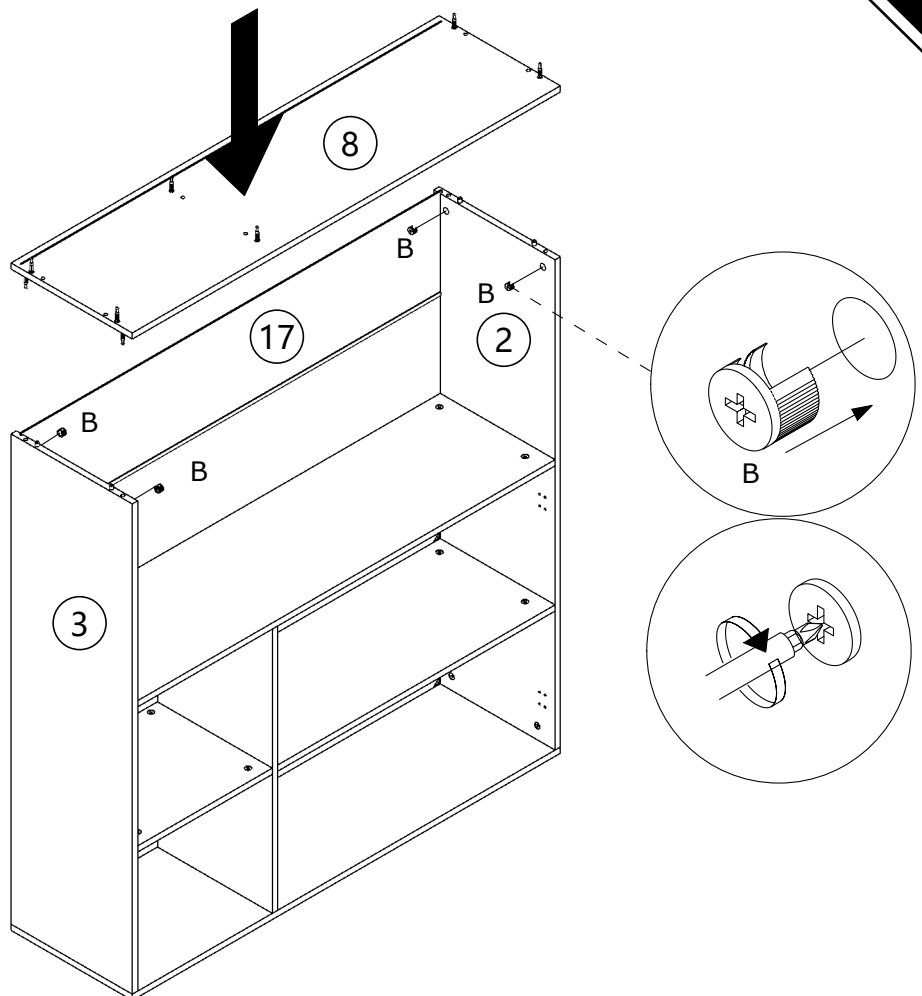
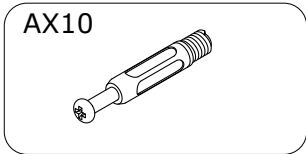
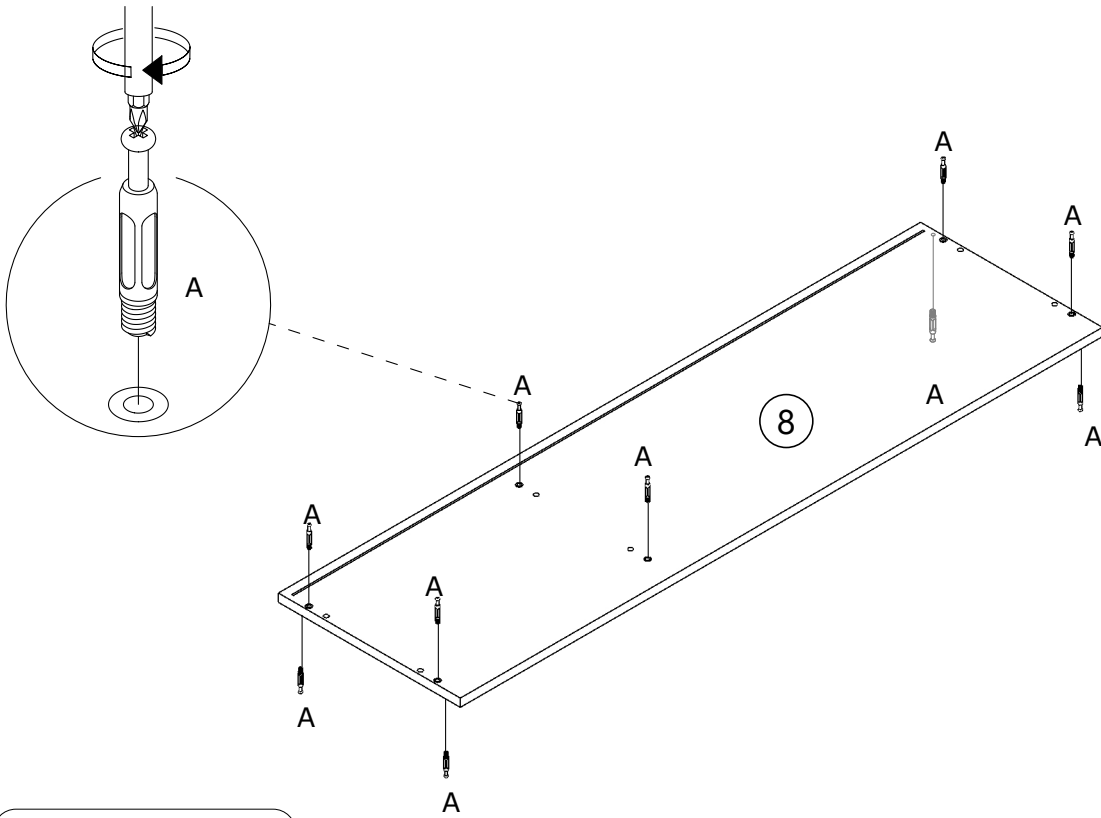

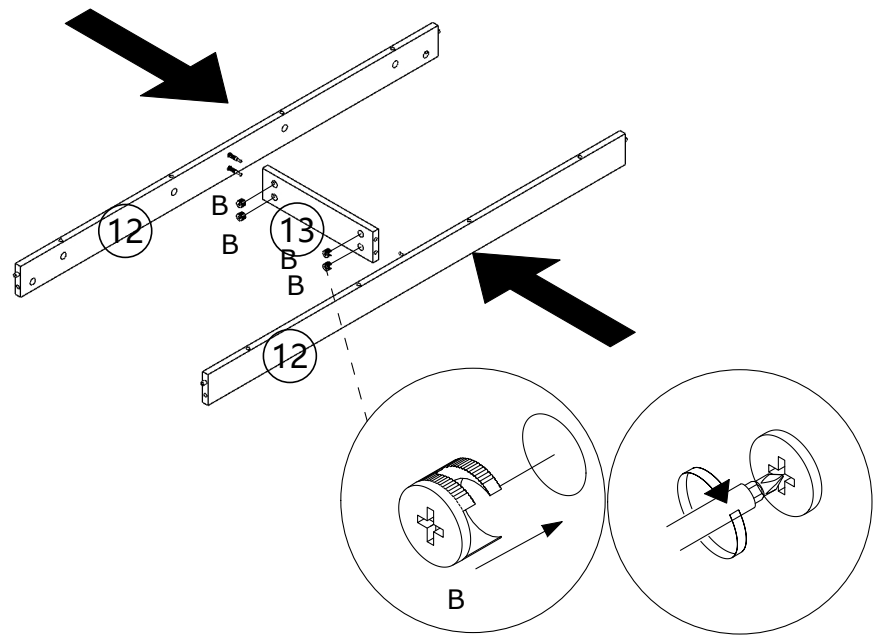
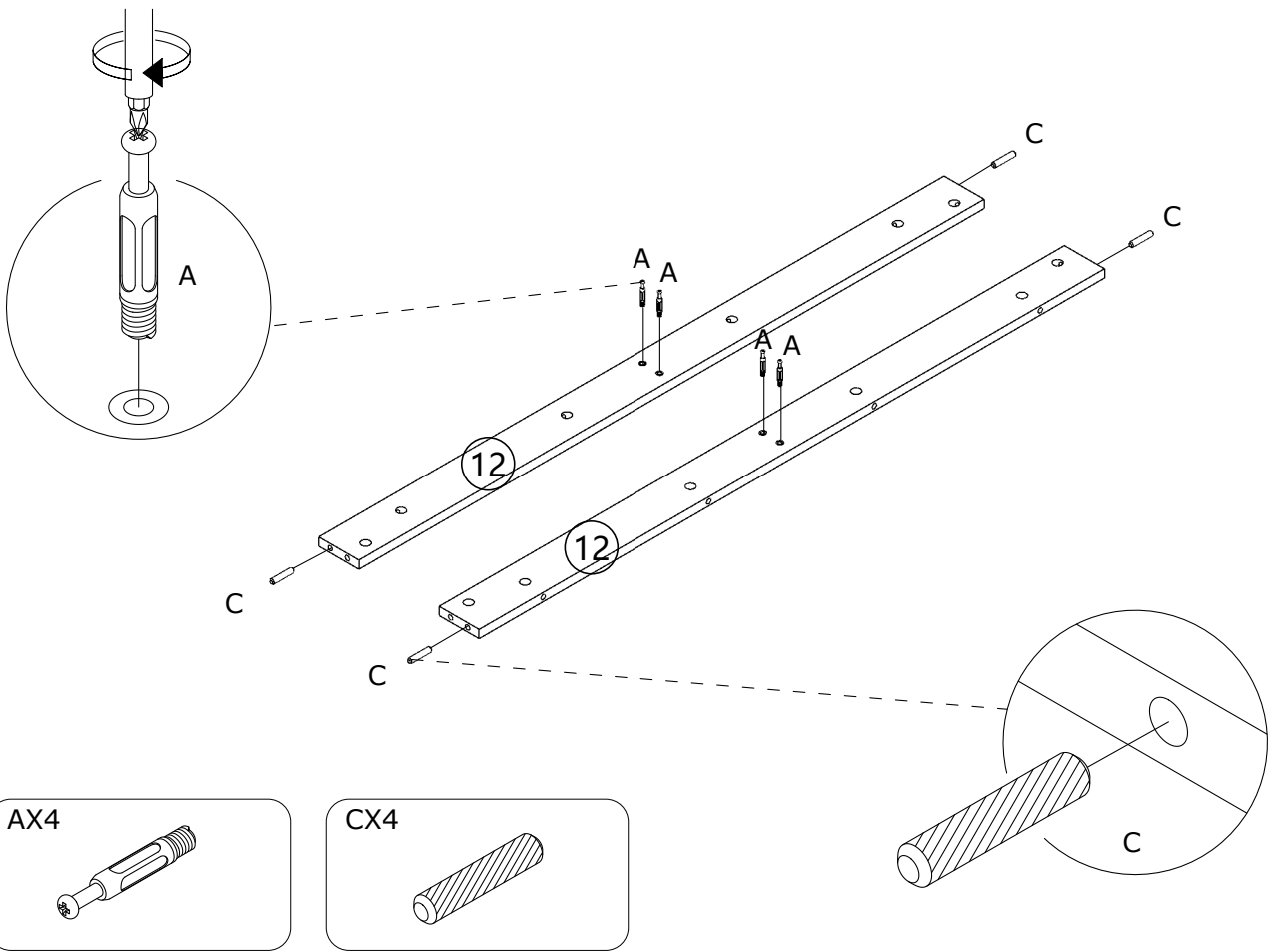

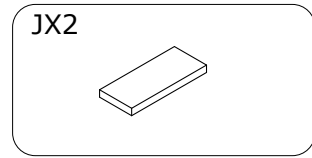
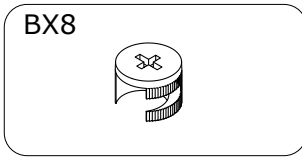
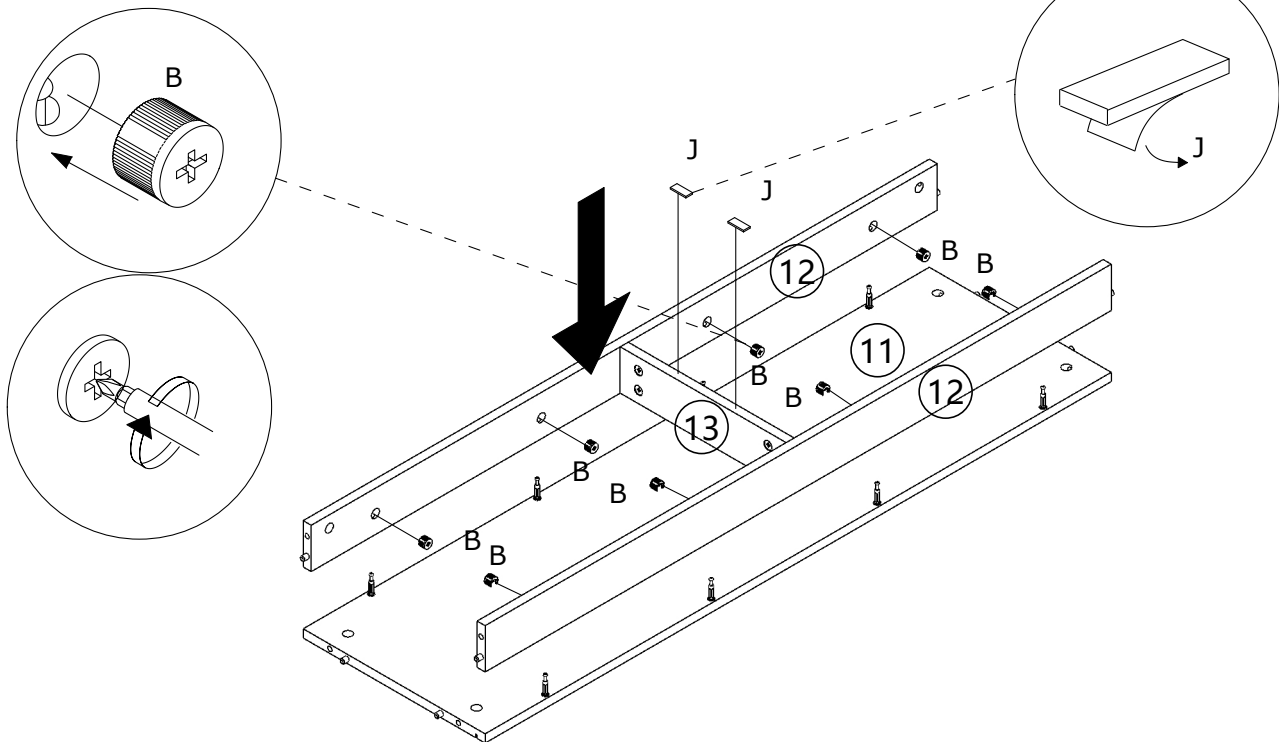
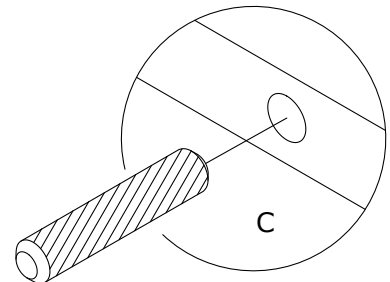
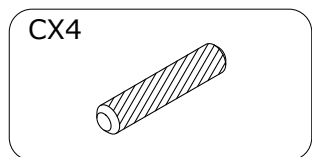
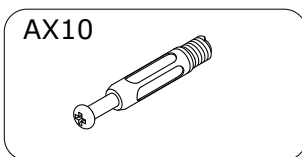
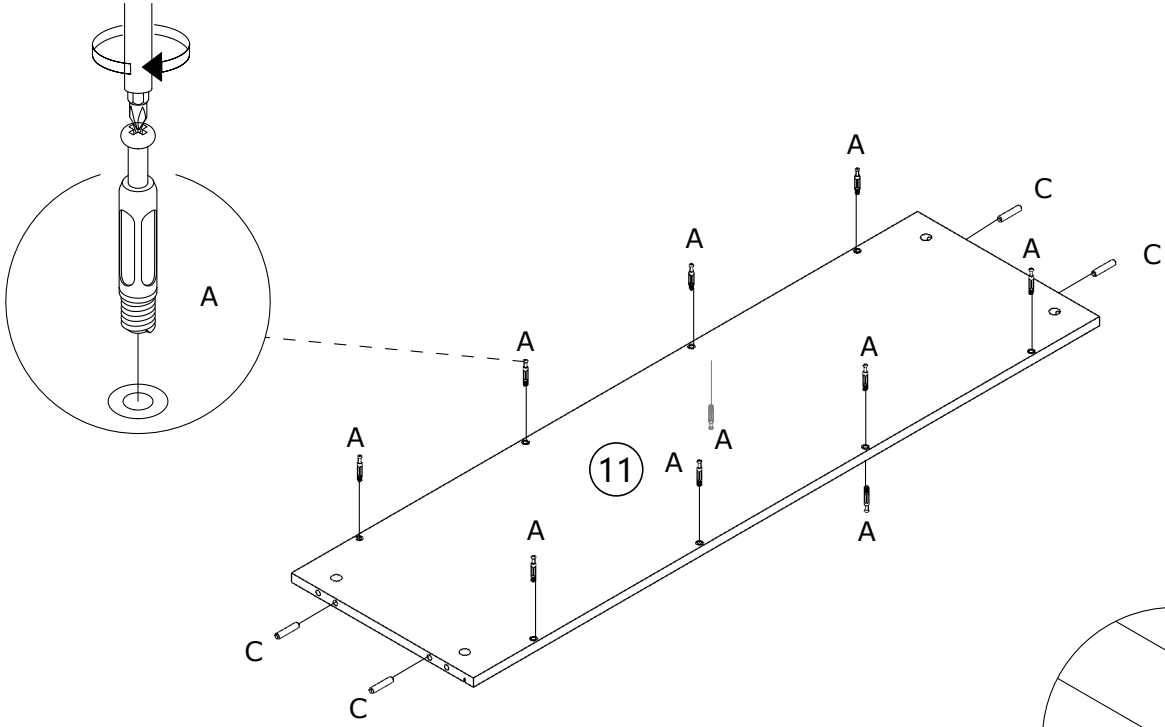

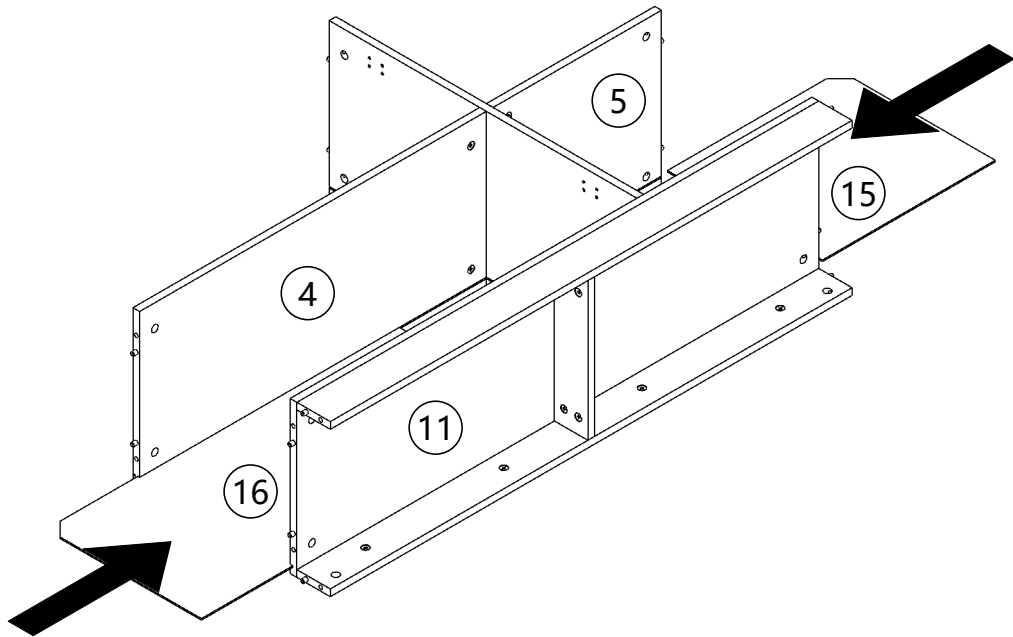
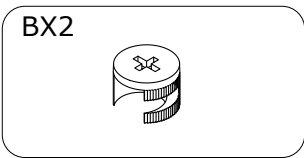
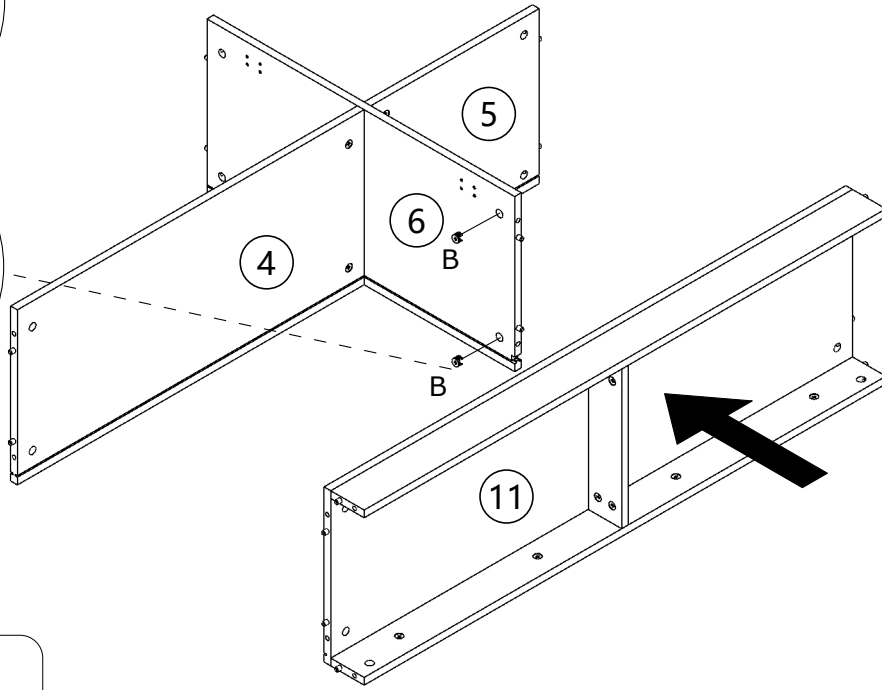
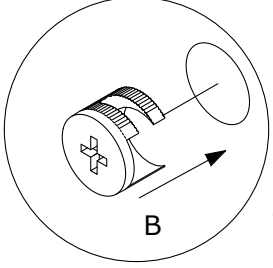
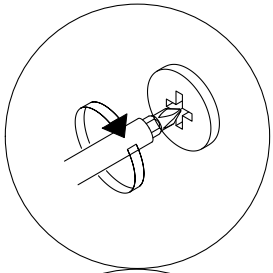

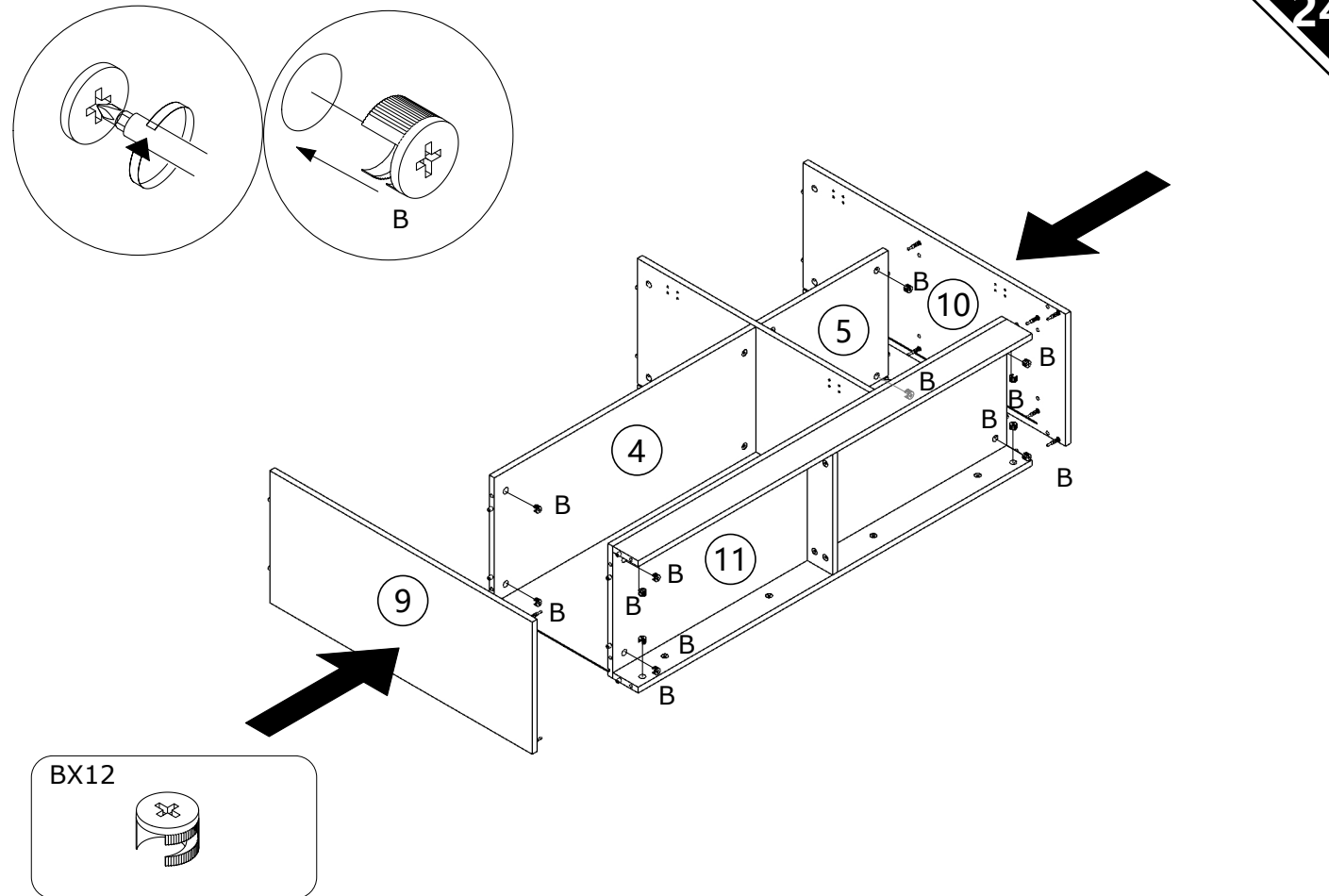
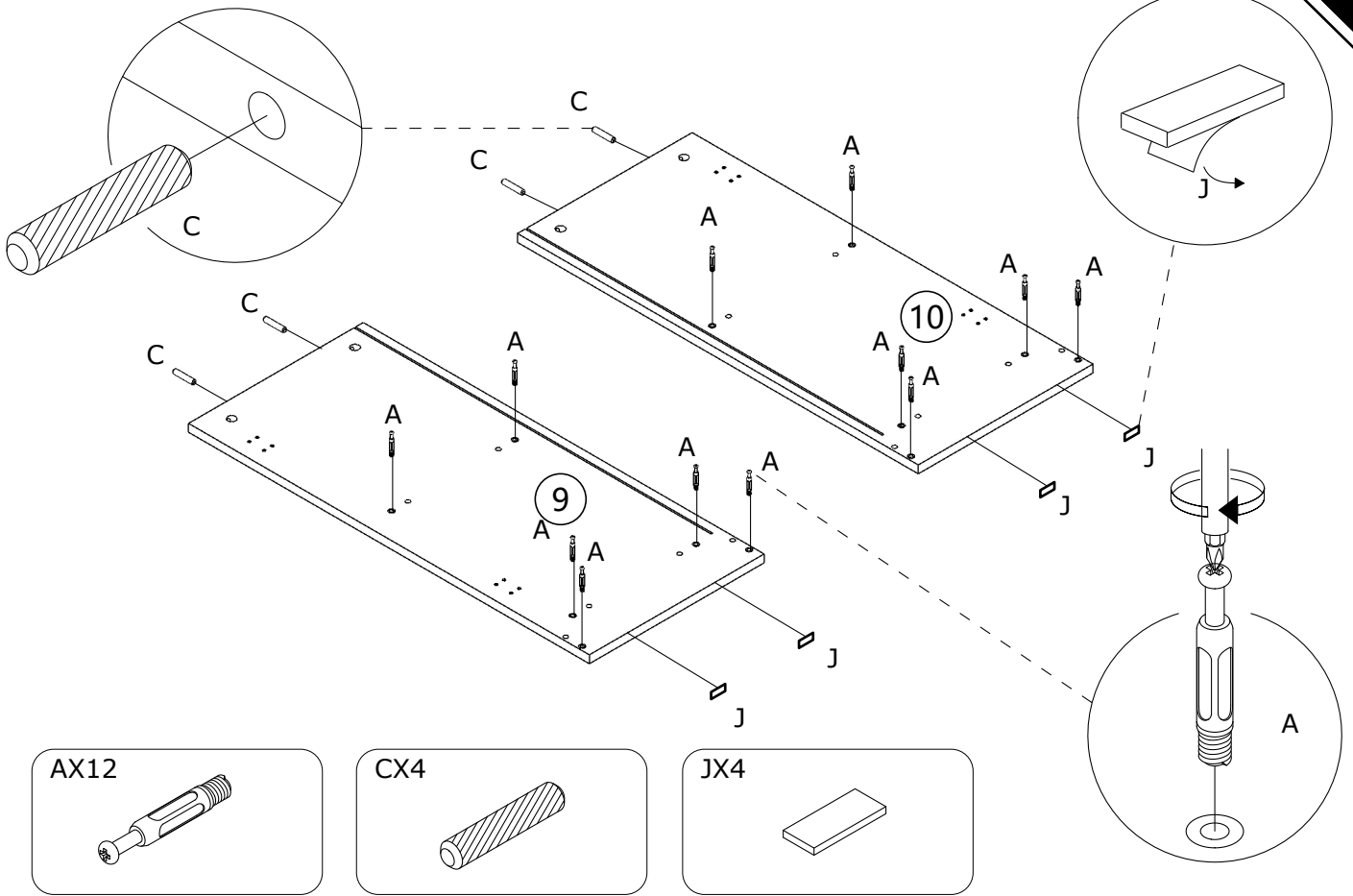

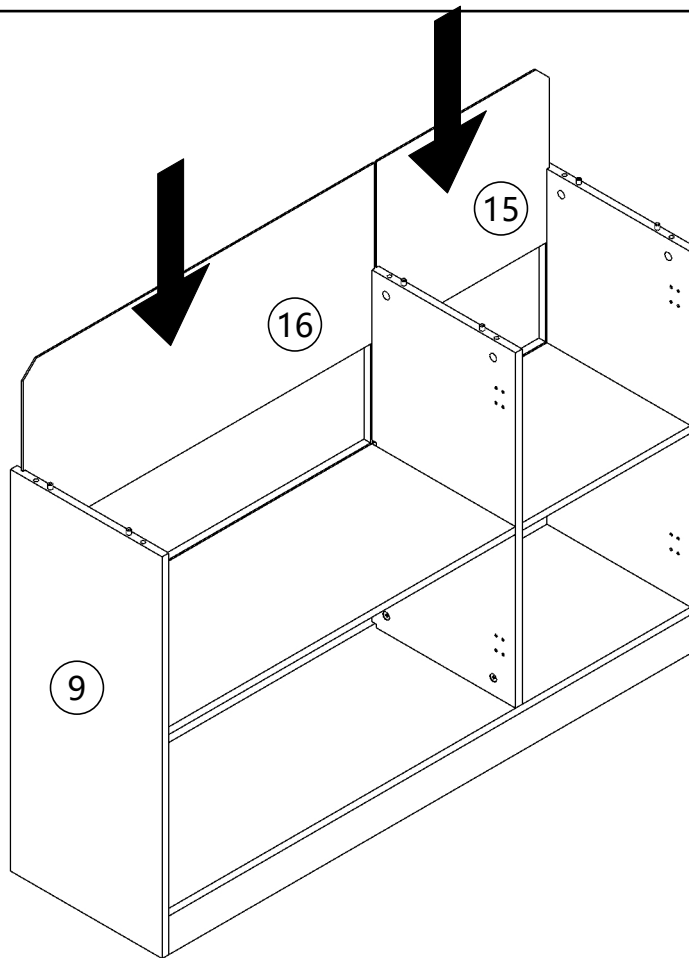

DE

Bitte stellen Sie die beiden Schrankteile aufrecht auf, um sie zusammenzubauen, und vermeiden Sie, dass die Rückwand nicht ausgerichtet werden kann.

EN

Please stand the two cabinet parts upright for assembly to avoid misalignment of the back panel

IT

Si prega di posizionare le due parti dell'armadio in verticale per l'assemblaggio, evitando che il pannello posteriore non possa essere allineato

FR

Veuillez placer les deux parties du meuble en position verticale pour l'assemblage afin d'éviter que le panneau arrière ne puisse pas être aligné.

ES

Por favor, coloque las dos partes del armario en posición vertical para el ensamblaje, evitando que el panel trasero no pueda alinearse.

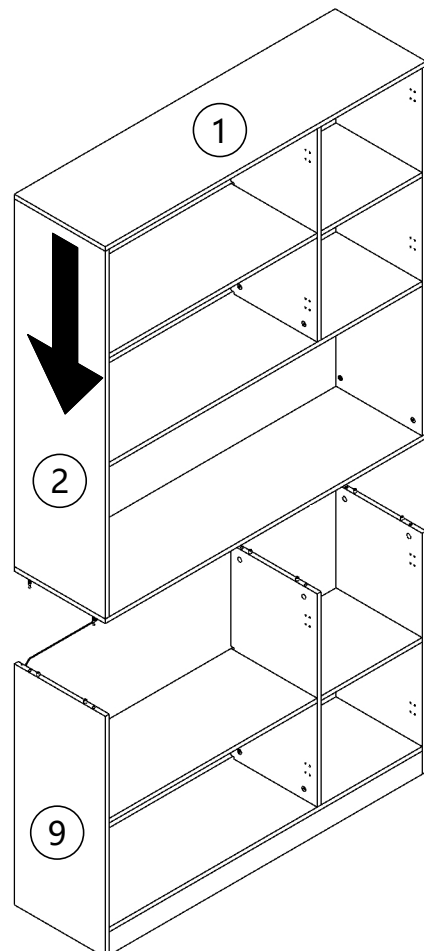

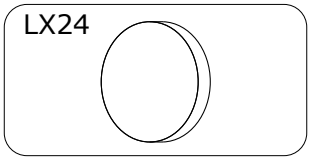
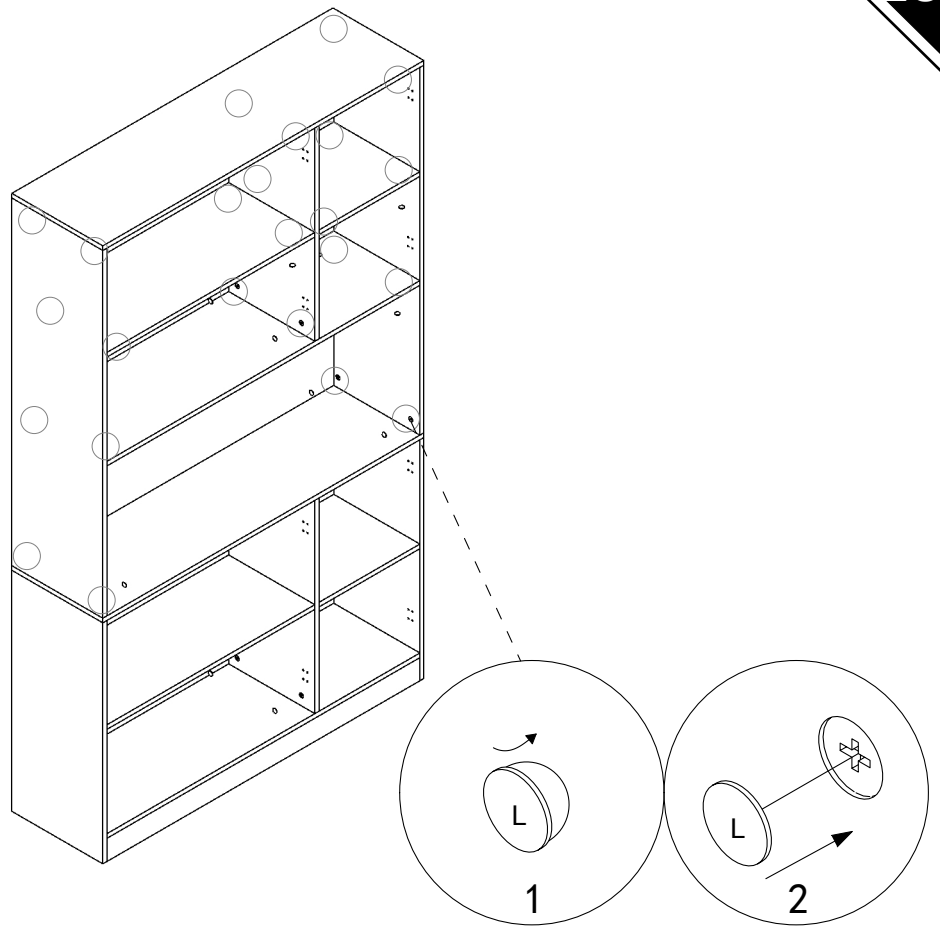
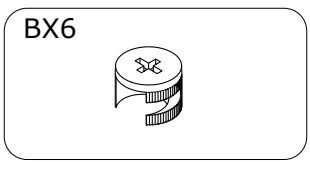
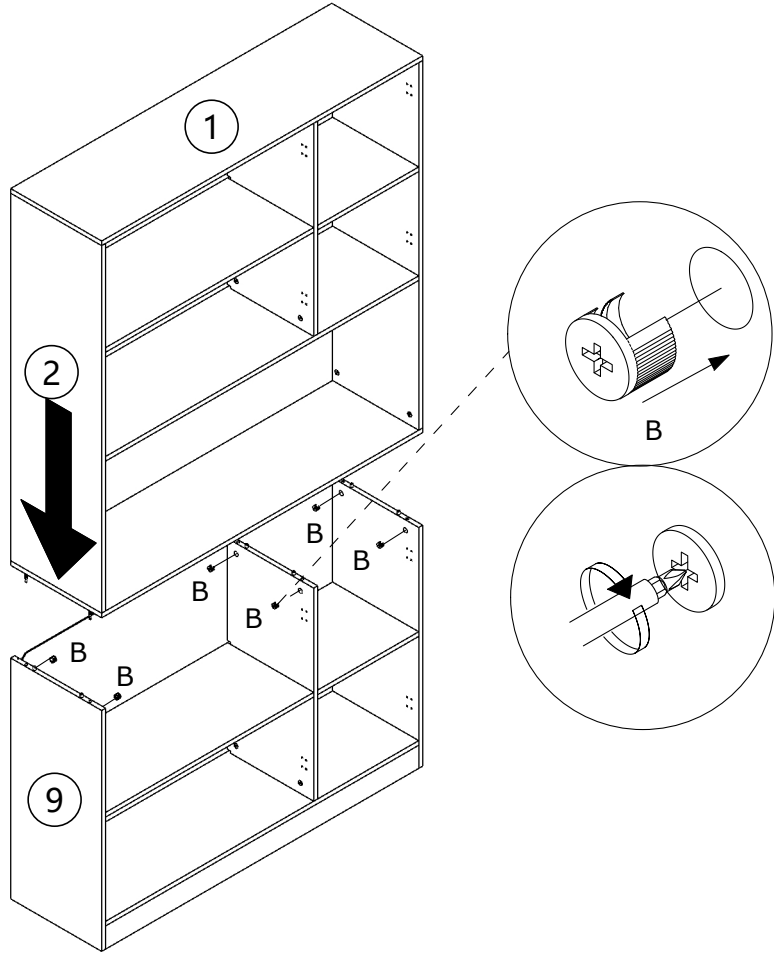

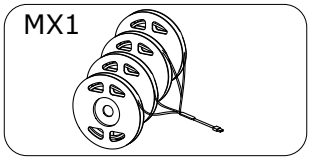
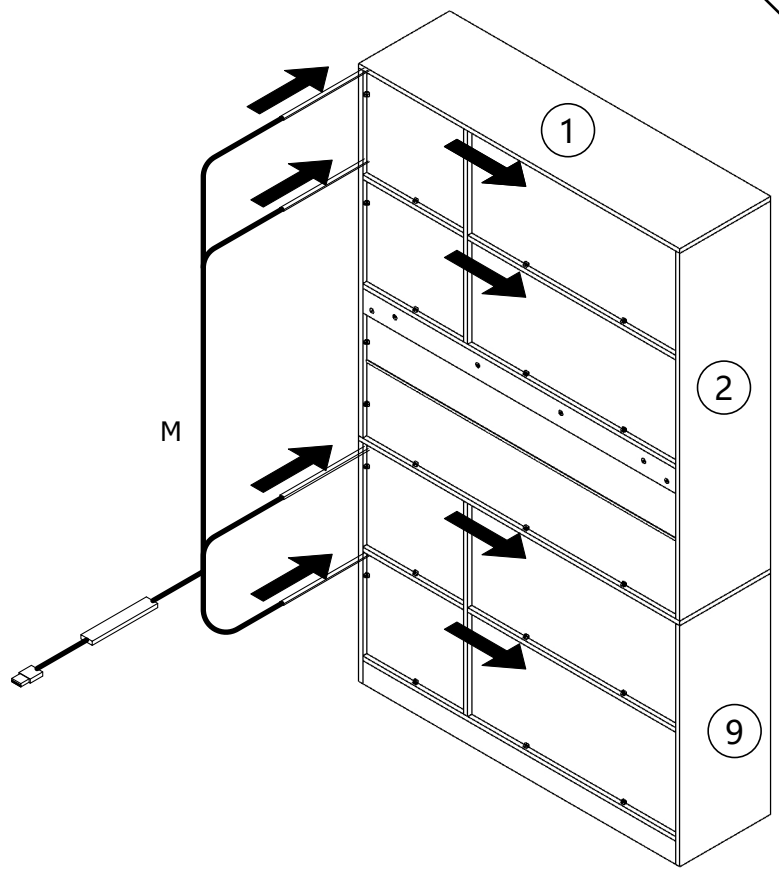
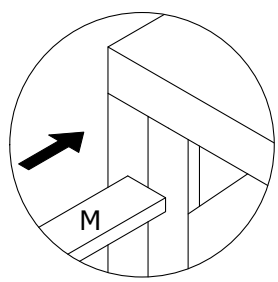
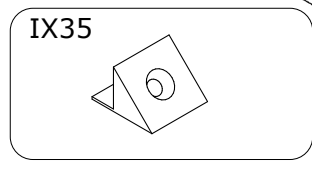
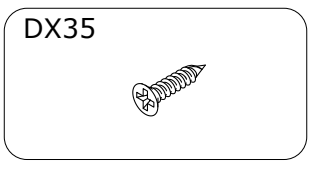
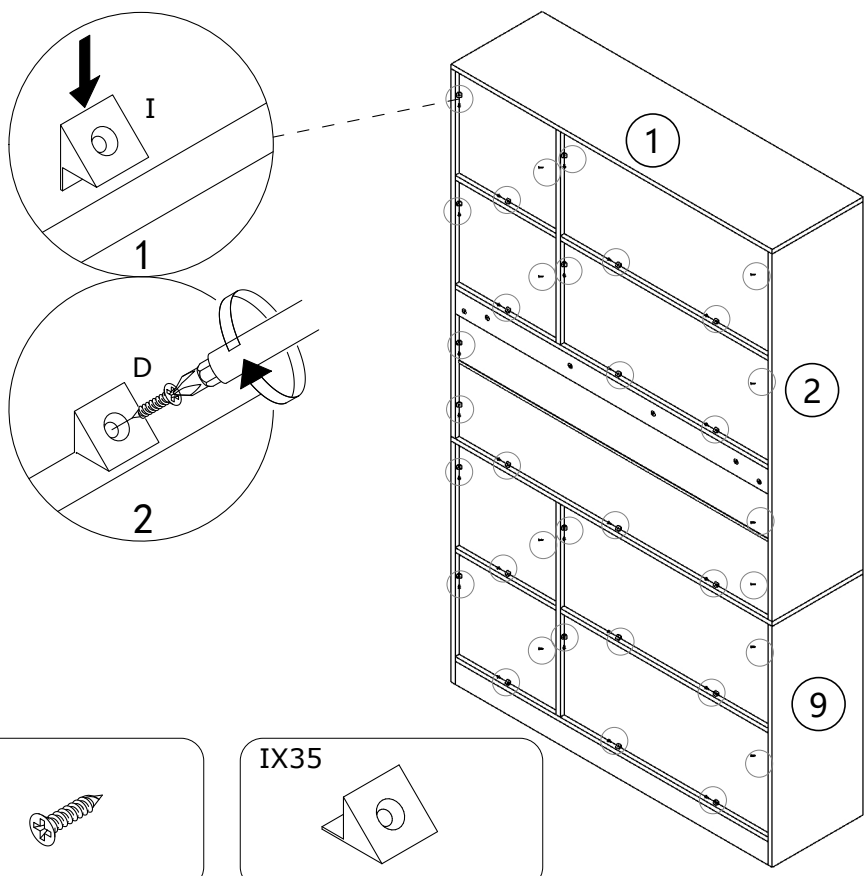

EN:Tear off the back tape  
 DE:Das Klebeband auf der Rückseite abziehen  
 FR:Retirez le ruban adhésif arrière  
 ES:Quitar la cinta trasera  
 IT:Strappare il nastro posteriore

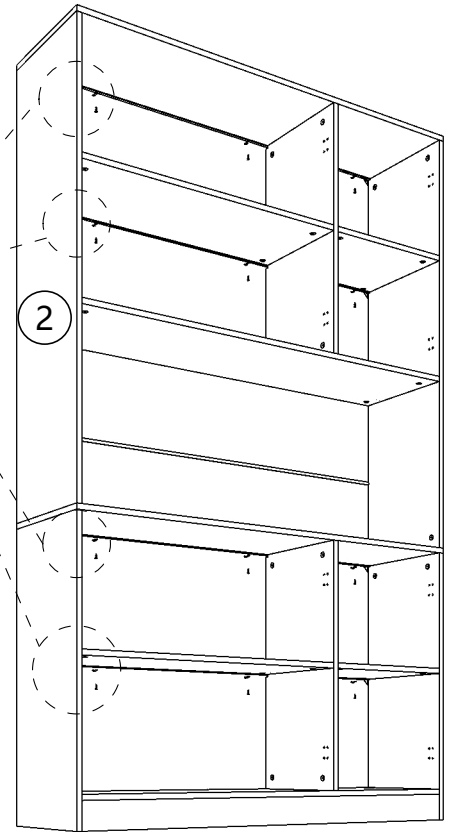
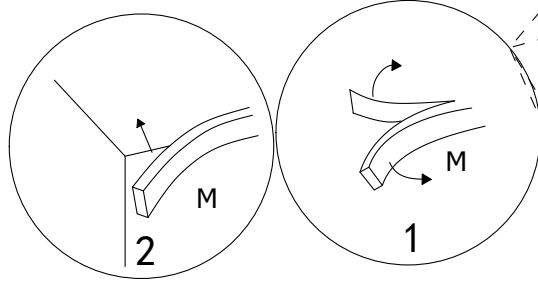

EN:Scan to download App control the Led light.  
 DE:Das led-display wird durchsucht.  
 FR:Scanner pour télécharger App contrôler la lumière Led.  
 IT:Scansiona per scaricare l'applicazione controlla la luce Led.  
 ES:Analice para descargar la aplicación control de la luz Led.

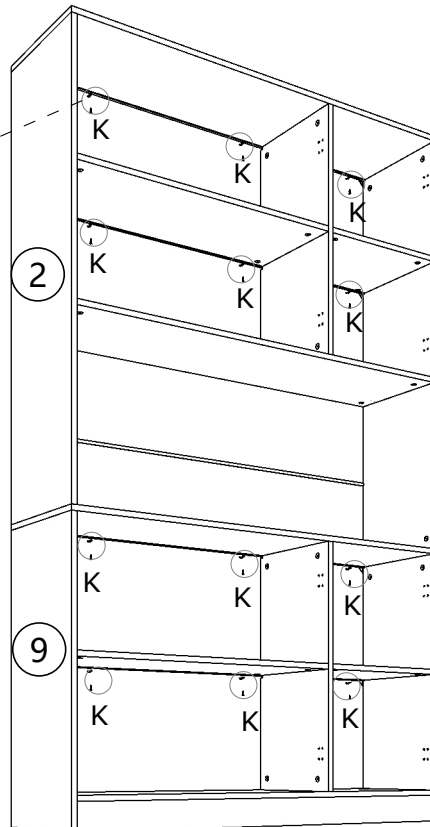
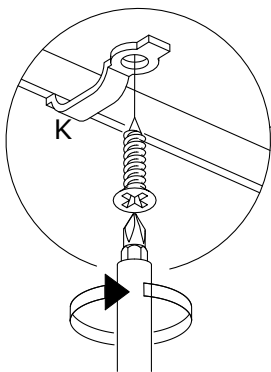

KX12



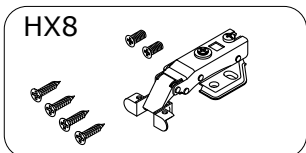
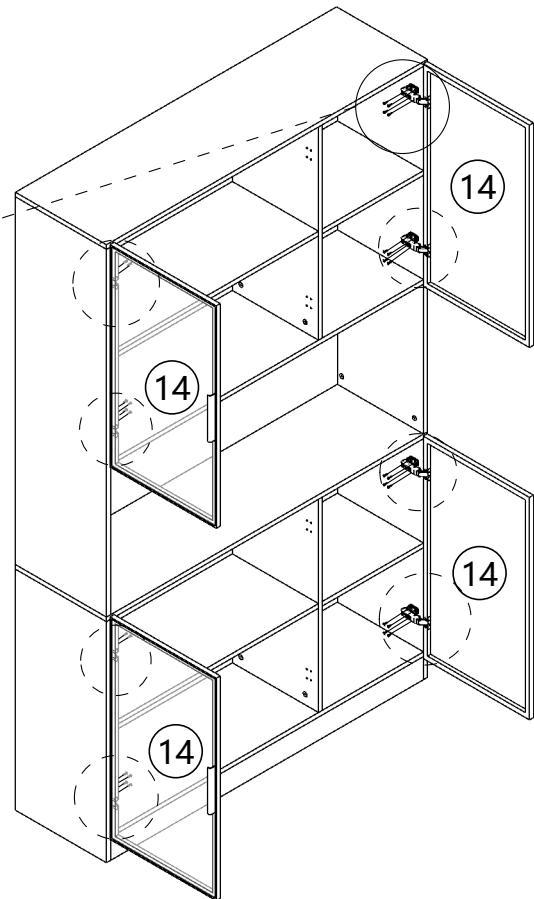
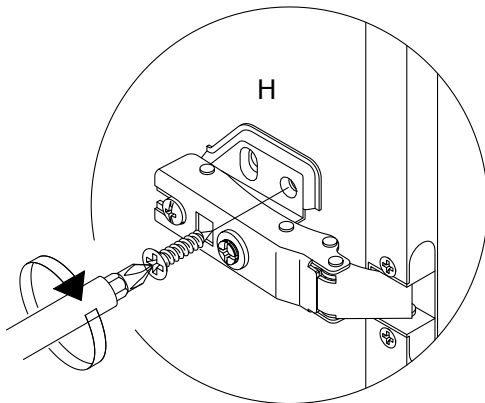
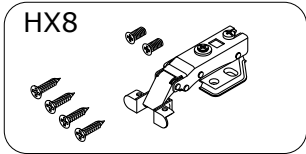
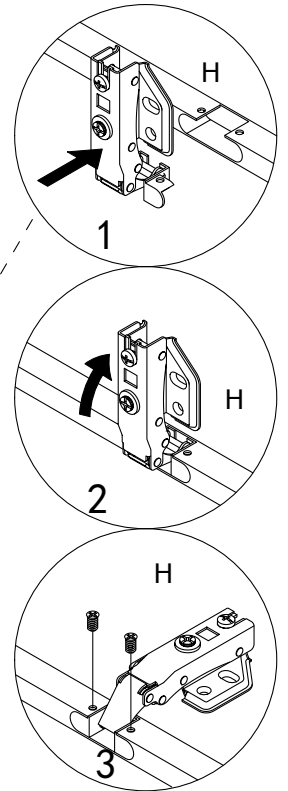
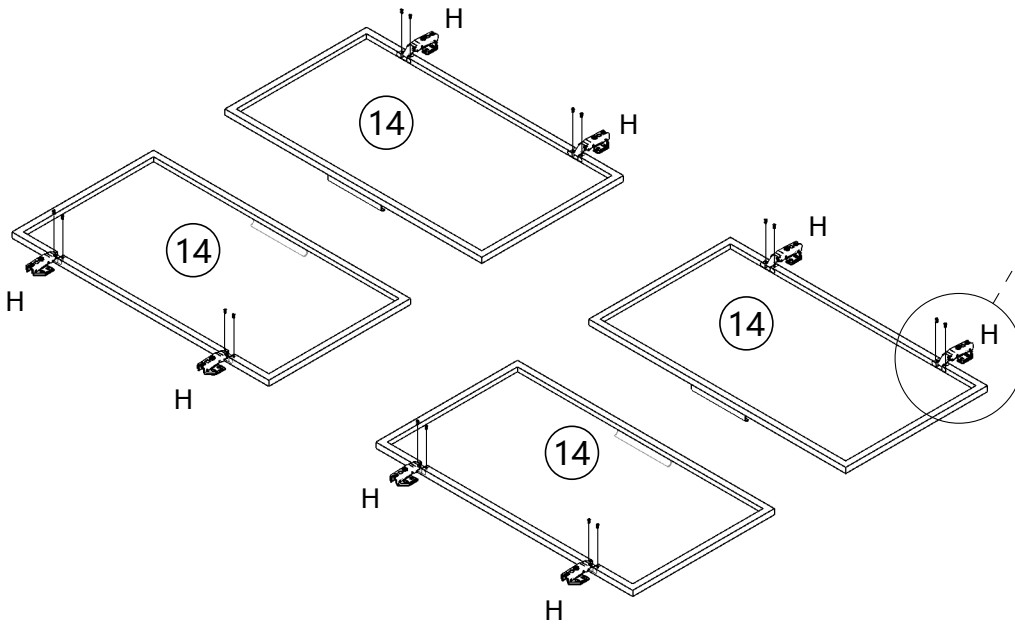

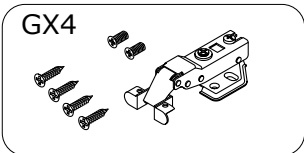
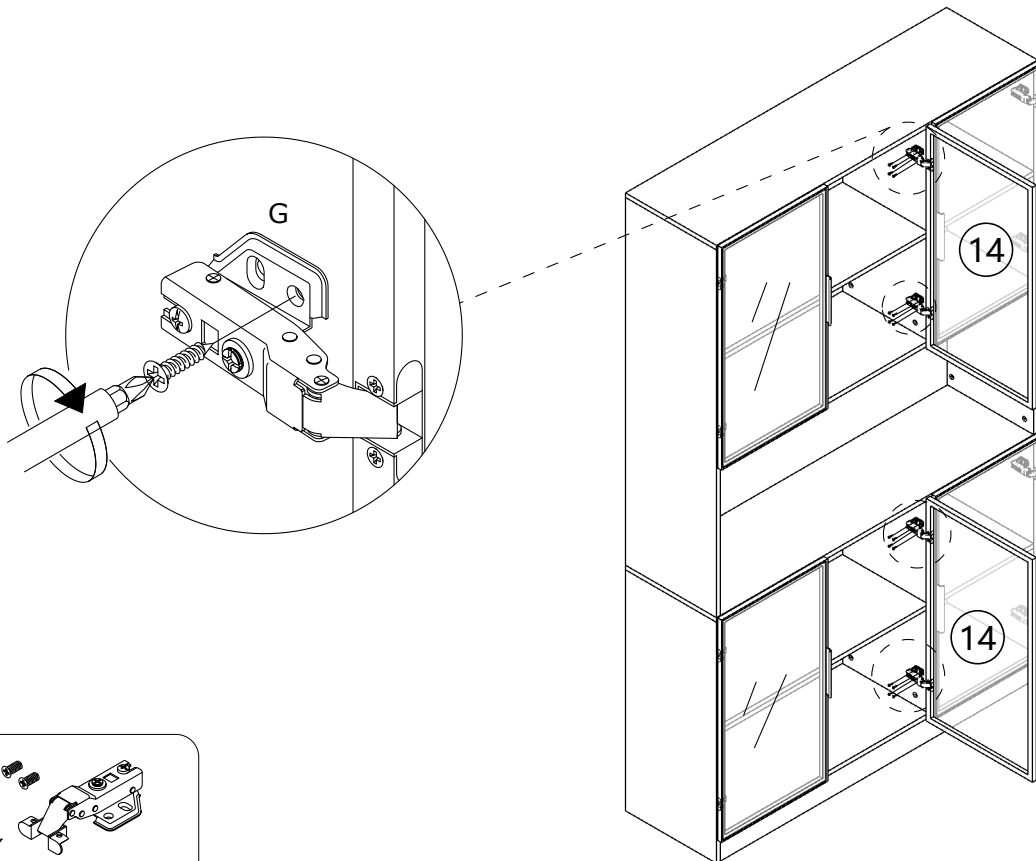
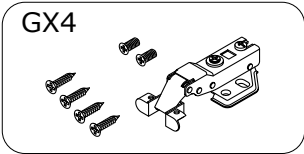
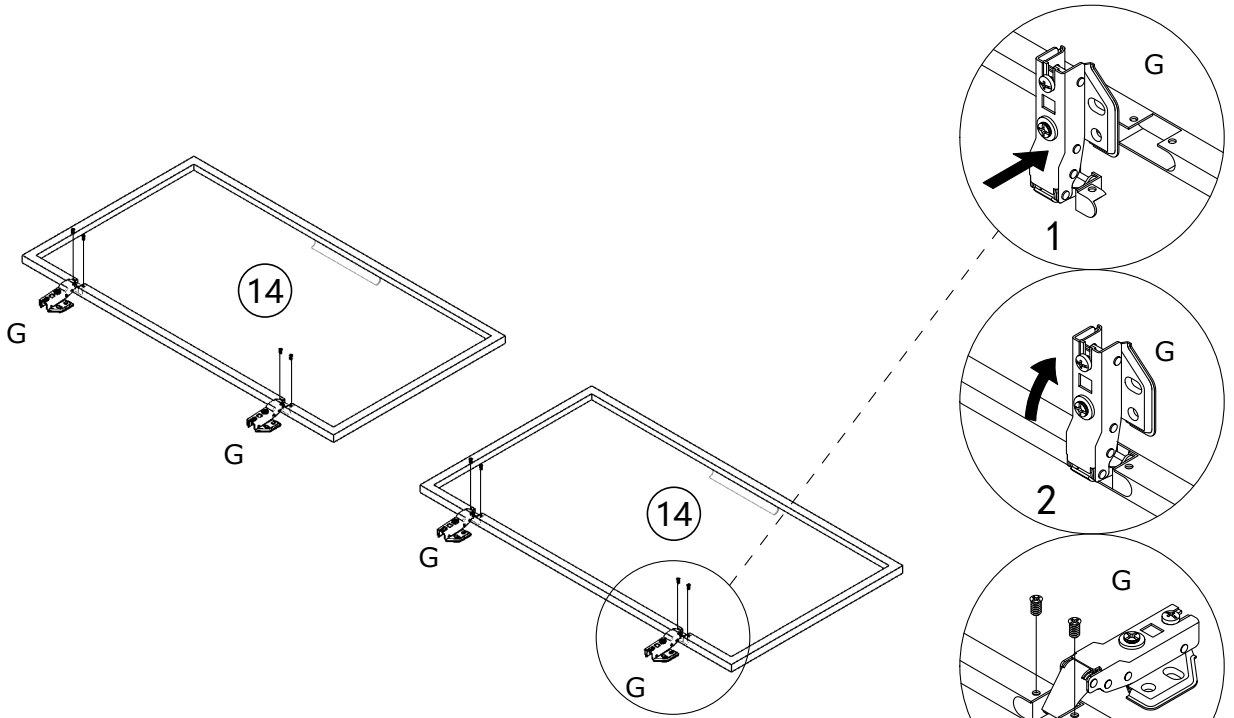

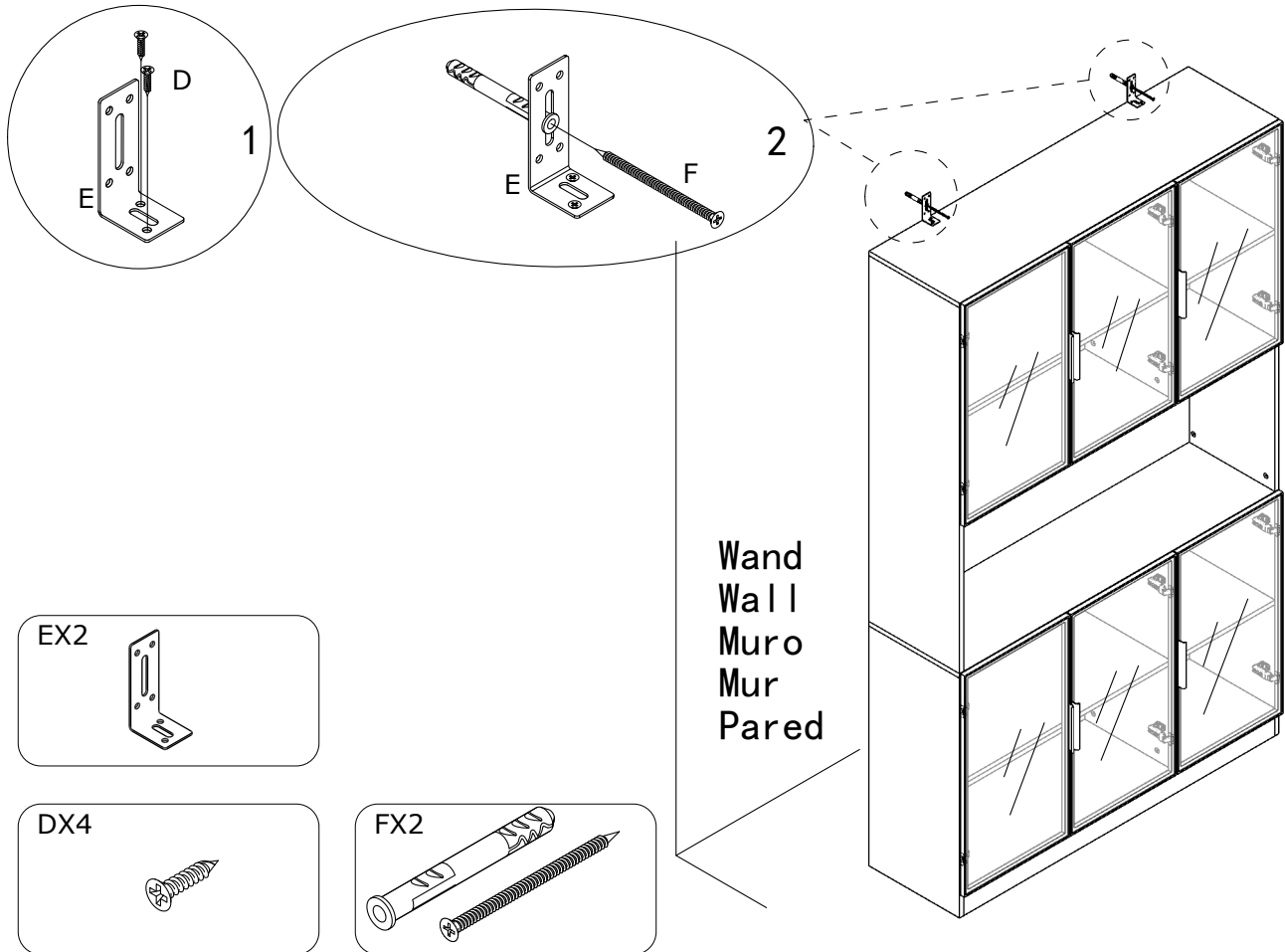

## DE

Wenn es sich um eine Massivwand handelt, verwenden Sie bitte Dehnungs- und selbstschneidende Schrauben; wenn es sich um eine Holzwand handelt, verwenden Sie nur selbstschneidende Schrauben. Bitte ziehen Sie die Schrauben nicht zu fest an.

## EN

If it is a solid wall., please use expansion and self-tapping screws; if it is a wooden wall, only use self-tapping screws. Please do not over-tighten the screws.

## IT

Se è un muro solido, si preaa di utilizzare viti ad espansione e autoperforanti: se è un muro di legno, utilizzare solo viti autoperforanti. Si prega di non stringere eccessivamente le viti.

## FR

Si le mur est massif, veuillez utliser des cheviles à expansion et des vis autotarau-deuses ; s'il s'agit d'unmur en bois, utilisez uniausement des vis autotarau-deuses. Veuillez ne pas trop serrer les vis.

## ES

Si es una pared sólida, utilice tornillos de expansión y autorroscantes; si es una pared de madera, utilice solo tornillos autorroscantes. No apriete demasiado los tornillos.

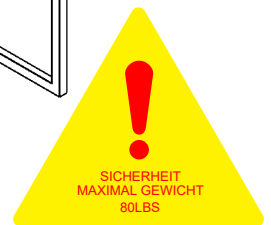
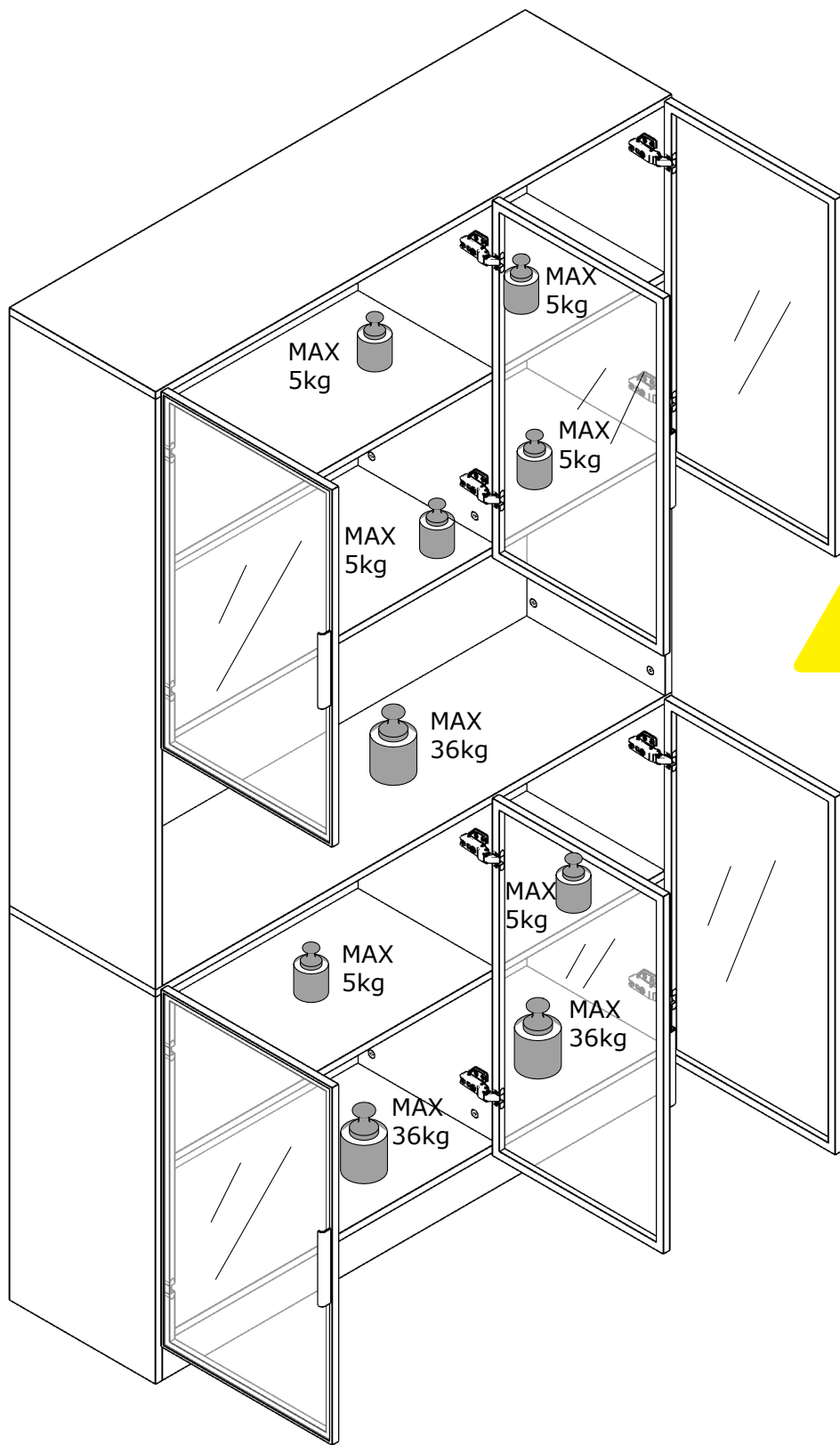

# Declaration of Conformity

Certificate Number:HX2501130045E-YG



EMC Directive 2014/30/EU

**Applicant** : Dongguan YIGuang Lighting Technology Co., LTD  
**Address** : 5 / F, Building A, Kexelong Building, No.9 Jie Southeast Road,  
Humen Town, Dongguan City, Guangdong Province  
**Manufacturer** : Dongguan YIGuang Lighting Technology Co., LTD  
**Address** : 5 / F, Building A, Kexelong Building, No.9 Jie Southeast Road,  
Humen Town, Dongguan City, Guangdong Province  
**Product** : LED Strip Suit  
**Model** : 2835-5050  
**Brand Name** : N/A  
**Test Report Number** : E2501130012-YG  
**Test Standard** : EN IEC 55015:2019/A11:2020  
EN 61547:2009  
EN IEC 61000-3-2:2019  
EN 61000-3-3:2013/A1:2019

The EUT described above has been tested by us with the listed standards and found in compliance with the council EMC directive 2014/30/EU. It is possible to use CE marking to demonstrate the compliance with this EMC Directive.

The certificate applies to the tested sample above mentioned only and shall not imply an assessment of the whole production. It is only valid in connection with the test report number:E2501130012-YG.



Huaxun testing (Shenzhen) Group Co., Ltd  
Address:1st Floor, Building 2, Bangkai Technology Park, No. 9 Guangyuan 5th Road,  
Tangjia Community, Fenghuang Street, Guangming District, Shenzhen, Guangdong China.  
Web.Site:<http://www.hx-lbt.org> Tel: 0755-27202251 E-mail:[huaxun@hx-lbt.org](mailto:huaxun@hx-lbt.org)

## APP-PROGRAMMANWENDUNG

Klicken, um  
Lampenliste  
anzuzeigen  
Farbrad  
wechseln

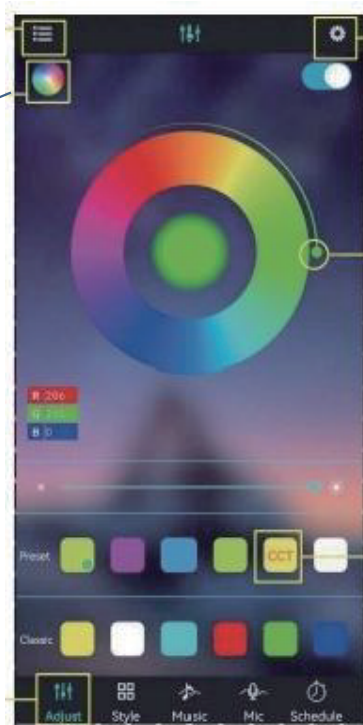

Klicken für  
Einstellungsansicht

Farbe anpassen

Farbanpassung  
per Quadrat-  
Symbol

Schnittstelle  
durch Klicken  
wechseln



## HINWEIS:

Detaillierte Anleitung im  
Menü "Guide"

## PRODUKTPARAMETER

- Bluetooth: BLEVA 2
- Eingangsspannung: 4.5~26V
- Betriebstemperatur: -25~75 °C
- Abmessungen: 43×22×11 mm
- Gewicht: 30g
- Max. Leistung: 144W (24V)

## VERBINDUNGSSCHRITTE

- ① LED-Farbstreifen & Controller verbinden, Controller einschalten
- ② QR-Code scannen zum App-Download:



- ③ App starten, Controller suchen & verbinden
- ④ Bluetooth-Drahtlossteuerung genießen

## PRODUKTMERKMALE

- Direkte Handy-Steuerung (20m Reichweite)
- Automatische Verbindung in 5 Sekunden
- Musikrhythmus-Synchronisation
- Gruppensteuerung
- Helligkeits-/Geschwindigkeitsregelung
- Unterstützt bis 10m RGB(W)-Streifen
- Automatische Sprachumschaltung (DE/EN)

## ANIMATIONSEFFEKTE

- Farbverläufe
- Einfarbige/ Zweifarbige Gradienten
- Monochrome/Bunte Blinkereffekte
- Farbspringen
- Musikresponsive Effekte

## APP PROGRAM USAGE



- Scan two-dimensional code download APP
- ①Connect LED color strip and controller, power on controller
  - ②Scan two-dimensional code download APP:



- ③Start APP, search and connect controller
- ④Enjoy the Bluetooth wireless control experience



Notes:  
detailed operating instructions,  
enter the menu "Guide":

Product Paramters:

- Bluetooth:BLEV4.2
- Input Voltage:4.5~26V
- Working Temp:-25~75°C
- Size:43\*22\*11mm
- Weight:30g
- Max Power:144W(24V)

LED mobile phone Bluetooth controllerProduct Features

- LED Bluetooth controller is directly via mobilephone control remote distance can reach 20m without the need to setupeasy to connect open the software within 5 seconds you can automatically connect the controller
- Flow the rhythm of the music changes
- Group control
- Brightness, speed addition and subtraction
- Maximum can be 10 meters RGB(W) strip
- The software shows that the text is based onthe language of the mobile phone set up automatic transformation of Chinese and English

ANIMATION EFFECTS:

- Colorful gradient
- All kinds of monochrome, double color gradient
- All kinds of monochrome, double color, colorfull flashing
- Colorful jump
- Follow the thymhm of the music chagnes

## APP-PROGRAMMANWENDUNG

Afficher la  
liste des lampes  
Farbrad  
Changer la  
Roue chromatique



Afficher les  
paramètres

Ajuster la couleur

Cliquez sur l'icône  
carrée pour ajuster  
la couleur.

Changer d'  
interface  
par clic



### REMARQUE :

Guide détaillé dans le menu  
"Guide"

### CARACTÉRISTIQUES

- Bluetooth : BLEVA 2
- Tension d'entrée : 4.5~26V
- Température : -25~75° C
- Dimensions : 43×22×11 mm
- Poids : 30g
- Puissance max : 144W (24V)

## ÉTAPES DE CONNEXION

- ① Connecter bande LED & contrôleur, allumer
- ② Scanner QR code pour télécharger l'app :



- ③ Lancer l'app, rechercher & connecter
- ④ Profiter du contrôle Bluetooth sans fil

## FONCTIONNALITÉS

- Contrôle direct par smartphone (20m)
- Connexion automatique en 5 secondes
- Synchronisation musicale
- Contrôle de groupe
- Réglage luminosité/vitesse
- Prise en charge bandes ≤10m RGB(W)
- Bascutage automatique FR/EN

## EFFETS D'ANIMATION

- Dégradés de couleurs
- Dégradés uni/bicolores
- Clignotements mono/colorés
- Saut de couleurs
- Effets réactifs à la musique

## UTILIZZO APP



## PASSI CONNESSIONE

- ① Collega striscia LED & controller, accendi
- ② Scansiona QR code per scaricare APP:



- ③ Avvia APP, cerca & connetti controller
- ④ Goditi controllo wireless Bluetooth



## NOTA:

Guida completa nel menu "Guide"

## SPECIFICHE:

- Bluetooth: BLEVA 2
- Tensione ingresso: 4.5~26V
- Temperatura: -25~75° C
- Dimensioni: 43×22×11 mm
- Peso: 30g
- Potenza max: 144W (24V)

## CARATTERISTICHE

- Controllo diretto smartphone (20m)
- Connessione automatica in 5 secondi
- Sincronizzazione ritmo musicale
- Controllo di gruppo
- Regolazione luminosità/velocità
- Supporto strisce ≤10m RGB (W)
- Auto switch IT/EN

## EFFETTI ANIMAZIONE:

- Sfumature colore
- Gradienti mono/bicolori
- Luci lampeggianti mono/colorate
- Salto colori
- Effetti reattivi alla musica

## USO DE LA APLICACIÓN

Mostrar lista de —  
Lámparas  
Cambiar rueda de color

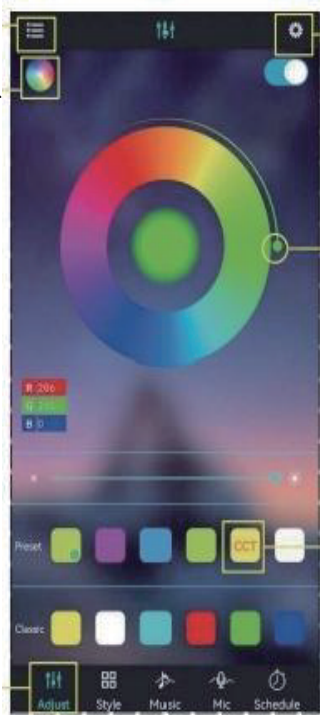

Ver ajustes

Ajustar el color

Clic para ajustar color  
con icono cuadrado

Cambiar interfaz  
haciendo clic —

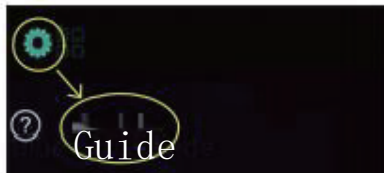

NOTA:

Guía completa en menú "Guide"

ESPECIFICACIONES:

- Bluetooth: BLEVA 2
- Voltaje entrada: 4.5~26V
- Temperatura: -25~75° C
- Tamaño: 43×22×11 mm
- Peso: 30g
- Potencia máx: 144W (24V)

## PASOS DE CONEXIÓN

- ① Conectar tira LED y controlador, encender
- ② Escanear QR para descargar APP:



- ③ Iniciar APP, buscar y conectar
- ④ Disfrutar control inalámbrico Bluetooth

## CARACTERÍSTICAS

- Control directo móvil (20m alcance)
- Conexión automática en 5 segundos
- Sincronización ritmo musical
- Control grupal
- Ajuste brillo/velocidad
- Soporte tiras ≤10m RGB(W)
- Auto cambio ES/EN

## EFFECTOS DE ANIMACIÓN:

- Degradados de color
- Transiciones mono/bicolores
- Destellos monocromáticos/color
- Salto de colores
- Efectos reactivos a música