

Montageanleitung | Instructions de montage Assembly Instructions | Instrucciones de montaje

N616P418441
N616P418442
N616P418443
N616P418444
200x140CM

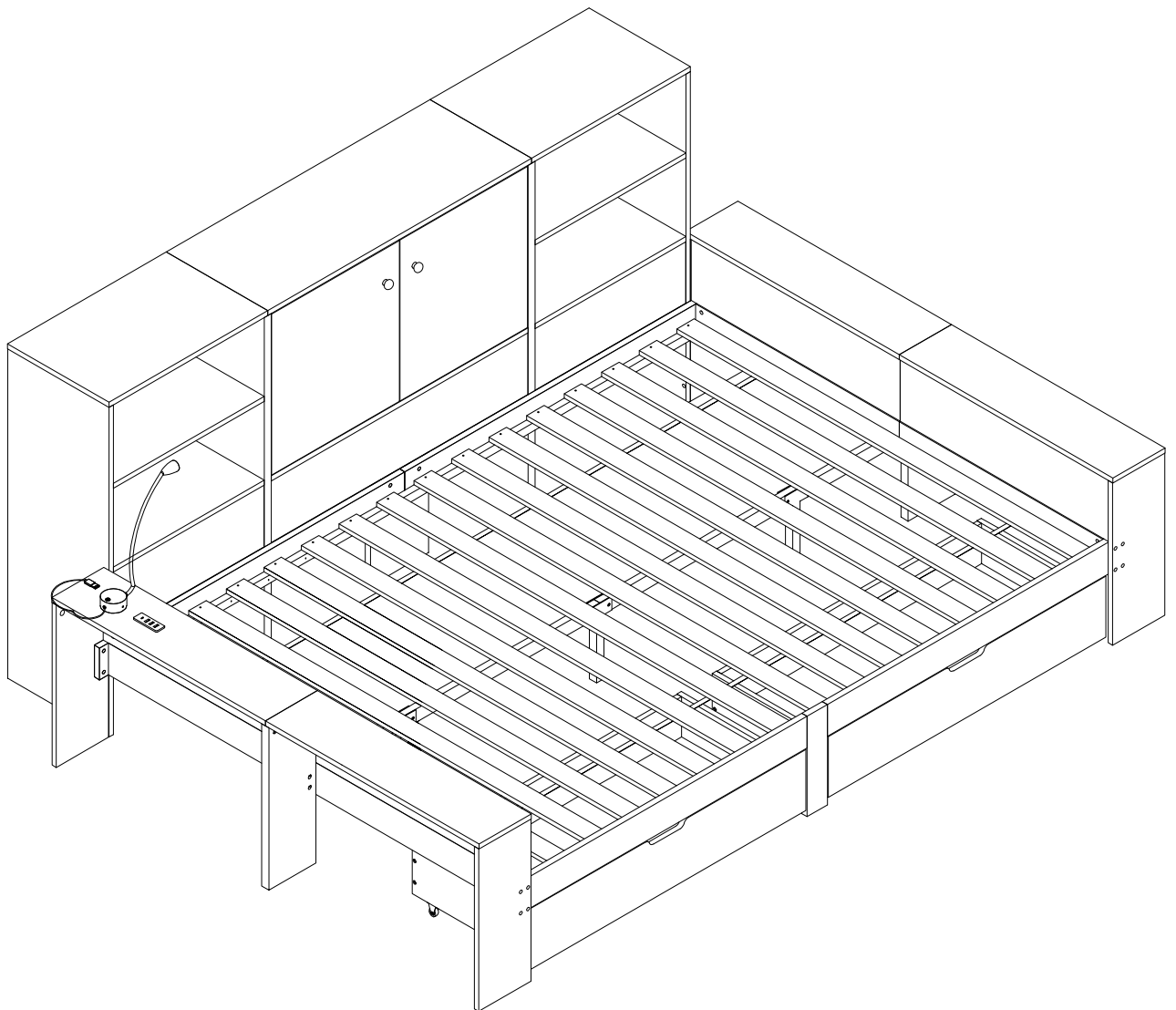
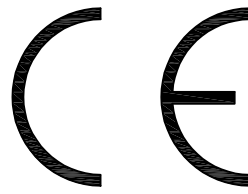

Points de collecte sur www.quefairedemesdechets.fr
Privilégiez la réparation ou le don de votre appareil !

Ⓞ This set comes in 4 boxes. If you do not receive a full set of 4 boxes, please contact our customer service.

Ⓞ Dieses Set wird in 4 Schachteln geliefert. Wenn Sie nicht ein komplettes Set von 4 Boxen erhalten, kontaktieren Sie bitte unseren Kundenservice.

Ⓞ Ce set est livré en 4 boîtes. Si vous ne recevez pas un jeu complet de 4 boîtes, veuillez contacter notre service clientèle.

English

IMPORTANT ! KEEP FOR FUTURE REFERENCE : READ CAREFULLY

- To be assembled by an adult. Assembly must be checked by an adult before use
- WARNING ! Keep all screws, small parts and plastic bags out of the reach of children
- Properly identify all parts before assembling
- Never use your item if any of its parts are broken or missing
- Should any problems arise, please contact our After Sales Service
- Manufacturer's instructions shall be followed at all times
- Care: Clean with a soft, dry cloth. In case of larger stains, carefully rub with a slightly damp, non-abrasive sponge
- Avoid the risk of fire by not placing furniture near sources of ignition or hot items
- Do not jump on the bed

Deutsch

WICHTIG ! ZUM SPÄTEREN NACHSCHLAGEN AUFBEWAHREN: SORGFÄLTIG LESEN

- Muss von einem Erwachsenen zusammengebaut werden. Der Zusammenbau muss vor dem Gebrauch von einem Erwachsenen überprüft werden
- WARNUNG! Bewahren Sie alle Schrauben, Kleinteile und Plastikbeutel außerhalb der Reichweite von Kindern auf
- Kennzeichnen Sie vor dem Zusammenbau alle Teile richtig
- Benutzen Sie Ihren Artikel niemals, wenn Teile gebrochen sind oder fehlen
- Sollten Probleme auftreten, wenden Sie sich bitte an unseren Kundendienst
- Die Anweisungen des Herstellers sind stets zu befolgen
- Pflege: Mit einem weichen, trockenen Tuch reinigen. Bei größeren Flecken vorsichtig mit einem leicht feuchten, nicht scheuernden Schwamm abreiben. nicht scheuernden Schwamm
- Vermeiden Sie die Gefahr eines Brandes, indem Sie die Möbel nicht in der Nähe von Zündquellen oder heißen Gegenständen aufstellen
- Nicht auf das Bett springen

Français

IMPORTANT ! CONSERVER POUR RÉFÉRENCE ULTÉRIEURE : LIRE ATTENTIVEMENT

- Le montage doit être effectué par un adulte. Le montage doit être vérifié par un adulte avant Utilisation
- ATTENTION ! Tenir les vis, les petites pièces et les sachets en plastique hors de portée des enfants
- Identifiez correctement toutes les pièces avant de les assembler
- N'utilisez jamais votre article si l'une de ses pièces est cassée ou manquante
- En cas de problème, veuillez contacter notre service après-vente
- Les instructions du fabricant doivent être respectées à tout moment
- Entretien : nettoyer avec un chiffon doux et sec. En cas de taches plus importantes, frotter soigneusement avec une éponge non abrasive légèrement humide. légèrement humide et non Abrasive
- Évitez les risques d'incendie en ne plaçant pas les meubles à proximité de sources d'inflammation ou d'objets chauds
- Ne pas sauter sur le lit

Italiano

IMPORTANTE! CONSERVARE PER RIFERIMENTO FUTURO: LEGGERE ATTENTAMENTE

- Deve essere assemblato da un adulto. L'assemblaggio deve essere controllato da un adulto prima dell'uso
- **ATTENZIONE!** Tenere tutte le viti, le piccole parti e i sacchetti di plastica fuori dalla portata dei bambini
- Identificare correttamente tutte le parti prima dell'assemblaggio
- Non utilizzare mai l'articolo se alcune parti sono rotte o mancanti
- In caso di problemi, si prega di contattare il nostro Servizio Post Vendita
- Le istruzioni del produttore devono essere sempre seguite
- Cura: Pulire con un panno morbido e asciutto. In caso di macchie più estese, strofinare accuratamente con una spugna leggermente umida e nonspugna leggermente umida e non abrasiva
- Evitare il rischio di incendio, non collocando i mobili vicino a fonti di accensione o a oggetti caldi
- Non saltare sul letto

Español

¡ IMPORTANTE ! CONSERVELO PARA FUTURAS CONSULTAS: LEA ATENTAMENTE

- Debe ser montado por un adulto. El montaje debe ser comprobado por un adulto antes del uso
- ADVERTENCIA Mantenga todos los tornillos, piezas pequeñas y bolsas de plástico fuera del alcance de los niños.
- Identifique correctamente todas las piezas antes de montarlas
 - Nunca utilice su artículo si alguna de sus piezas está rota o falta
 - Si surge algún problema, póngase en contacto con nuestro Servicio Postventa
 - Las instrucciones del fabricante deben seguirse en todo momento
 - Cuidado: Limpiar con un paño suave y seco. En caso de manchas más grandes, frote cuidadosamente con una esponja no abrasiva ligeramente humedecida.
 - Evite el riesgo de incendio no colocando los muebles cerca de fuentes de ignición u objetos calientes.
 - No saltar sobre la cama.

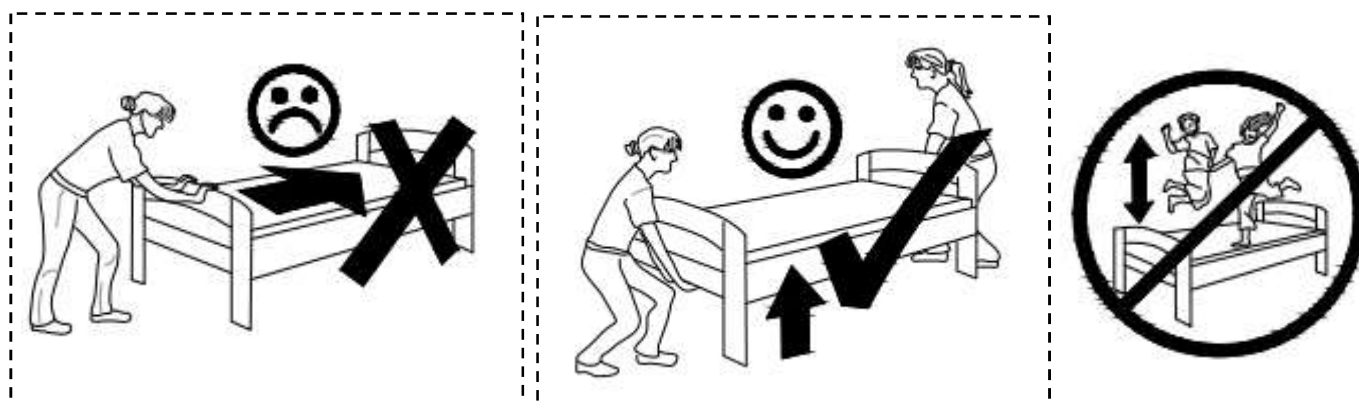

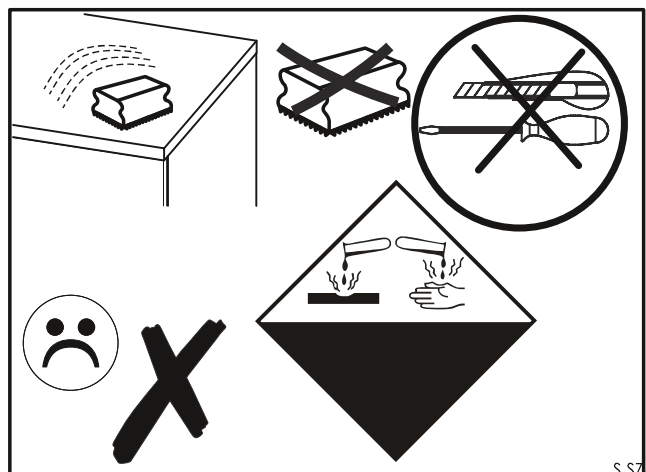
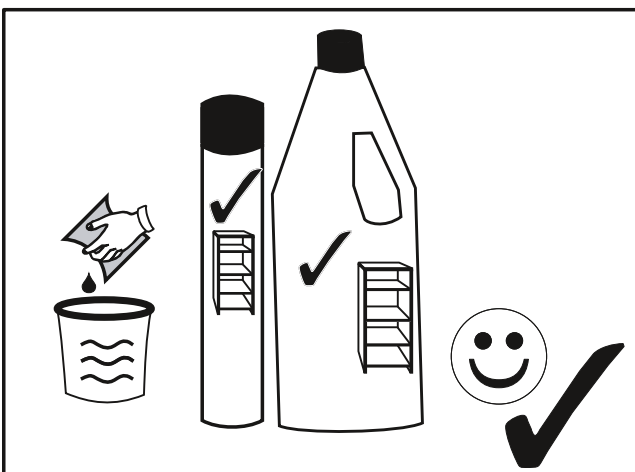
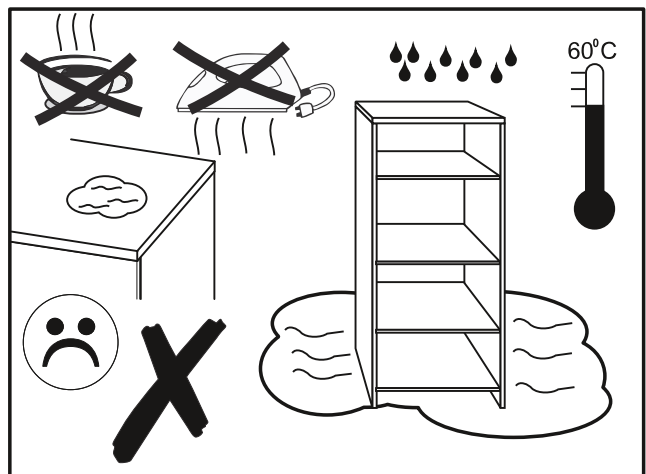
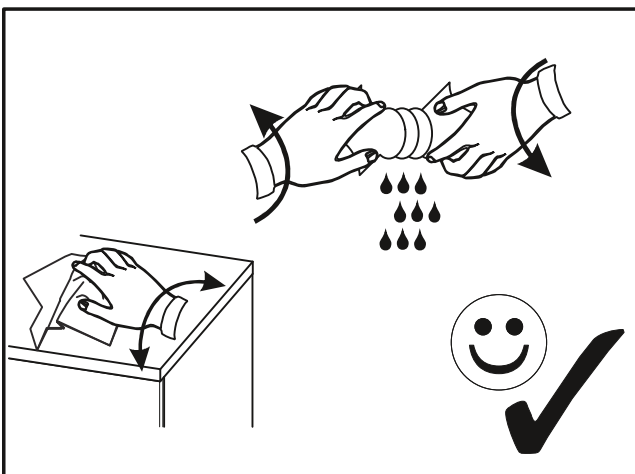
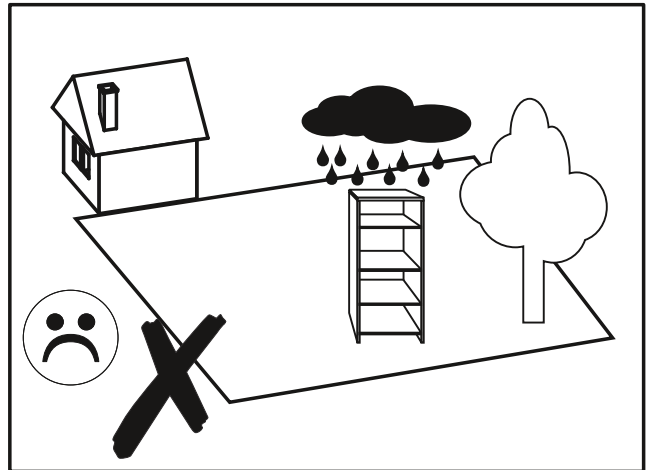
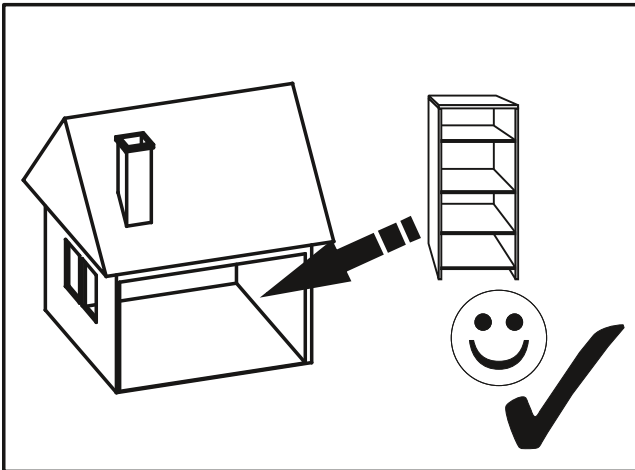



[DE]

Warnung: Lesen Sie diese Anleitung vor dem Zusammenbau bitte vollständig durch. Überprüfen Sie, ob Sie alle auf den Seiten aufgeführten Komponenten und Werkzeuge haben. Bewahren Sie die Anleitung zum späteren Nachschlagen auf. Teile des Zusammenbaus lassen sich mit 2 Personen leichter durchführen. Suchen Sie bei Bedarf professionelle Hilfe.

Warnung: Legen Sie alle Teile auf eine ebene Fläche. Legen Sie eine weiche Decke oder Ähnliches darunter, um sie vor Kratzern oder Flecken zu schützen. Vermeiden Sie es, Komponenten über den Boden zu ziehen oder zu schieben.

Warnung: Überprüfen Sie regelmäßig alle Beschläge und Befestigungen, um sicherzustellen, dass sie sicher sind und um Unfälle zu vermeiden. Wenn Teile fehlen, kaputt, beschädigt oder abgenutzt sind, verwenden Sie das Produkt nicht weiter, bis es mit vom Hersteller autorisierten Teilen repariert wurde.

Warnung: Lassen Sie Kinder nicht auf die Möbel klettern, da dies zum Umkippen und zu schweren Verletzungen führen kann. Bauen Sie die Möbel außerhalb der Reichweite von Kindern zusammen.

Warnung: Stellen Sie die Möbel nicht in die Nähe von Feuerquellen oder heißen Gegenständen, um Brandgefahr zu vermeiden.

Warnung: Reinigen Sie die Möbel mit einem feuchten Tuch oder Alkohol. Verwenden Sie keine Reinigungsmittel mit ätzenden Chemikalien.

Warnung: Dieses Produkt ist mit einer Kippschutzvorrichtung ausgestattet. Bitte installieren Sie diese Vorrichtung unbedingt, um unnötige Verletzungen durch Umkippen zu vermeiden.

[EN]

Warning: Please read these instructions fully before starting assembly. Check you have all the components and tools listed on pages. Keep the instructions for later reference. Parts of the assembly will be easier with 2 people. Seek professional assistance if necessary.

Warning: Please place all parts on a flat surface. Place a soft blanket or similar underneath to protect against scratches or stains. Avoid dragging or sliding components across the floor.

Warning: Regularly check all fittings and fastenings to ensure they are secure and to prevent accidents. If any parts are missing, broken, damaged, or worn, discontinue use of the product until repairs have been made using factory authorized parts.

Warning: Do not allow children to climb on the furniture as this may result in tipping and serious personal injury. Assemble the furniture away from the reach of children.

Warning: Do not place furniture close to fire sources or high-temperature objects to avoid the risk of fire. Do not place furniture in damp environments to prevent material damage.

Warning: Clean furniture with a damp cloth or alcohol, avoid using cleaning agents containing corrosive chemicals.

Warning: This product is equipped with an anti-tilt device. Please be sure to install this device to prevent unnecessary injuries caused by tipping.

[FR]

Avertissement : Veuillez lire attentivement ces instructions avant de commencer l'assemblage. Vérifiez que vous disposez de tous les composants et outils répertoriés sur les pages. Conservez les instructions pour référence ultérieure. Certaines parties de l'assemblage seront plus faciles à 2 personnes. Demandez l'aide d'un professionnel si nécessaire.

Avertissement : Veuillez placer toutes les pièces sur une surface plane. Placez une couverture douce ou similaire en dessous pour les protéger des rayures ou des taches. Évitez de faire glisser les composants sur le sol.

Avertissement : Vérifiez régulièrement tous les raccords et fixations pour vous assurer qu'ils sont bien fixés et

pour éviter les accidents. Si des pièces manquent, sont cassées, endommagées ou usées, cessez d'utiliser le produit jusqu'à ce que des réparations aient été effectuées à l'aide de pièces autorisées par l'usine.

Avertissement : Ne laissez pas les enfants grimper sur les meubles car cela pourrait entraîner un basculement et des blessures graves. Assemblez les meubles hors de portée des enfants.

Avertissement : Ne placez pas les meubles à proximité de sources de feu ou d'objets à haute température pour éviter tout risque d'incendie.

Avertissement : Nettoyez les meubles avec un chiffon humide ou de l'alcool, évitez d'utiliser des produits de nettoyage contenant des produits chimiques corrosifs.

Avertissement : Ce produit est équipé d'un dispositif anti-basculement. Assurez-vous d'installer ce dispositif pour éviter les blessures inutiles causées par un basculement.

[IT]

Attenzione: leggere attentamente queste istruzioni prima di iniziare il montaggio. Verificare di avere tutti i componenti e gli strumenti elencati nelle pagine. Conservare le istruzioni per riferimento futuro. Alcune parti del montaggio saranno più facili con 2 persone. Se necessario, chiedere assistenza professionale.

Attenzione: posizionare tutte le parti su una superficie piana. Posizionare una coperta morbida o simile sotto per proteggere da graffi o macchie. Evitare di trascinare o far scivolare i componenti sul pavimento.

Attenzione: controllare regolarmente tutti i raccordi e i dispositivi di fissaggio per assicurarsi che siano sicuri e per prevenire incidenti. Se alcune parti sono mancanti, rotte, danneggiate o usurate, interrompere l'uso del prodotto fino a quando non siano state eseguite le riparazioni utilizzando parti autorizzate dalla fabbrica.

Attenzione: non consentire ai bambini di arrampicarsi sui mobili poiché ciò potrebbe causare ribaltamenti e gravi lesioni personali. Montare i mobili lontano dalla portata dei bambini.

Attenzione: non posizionare i mobili vicino a fonti di fuoco o oggetti ad alta temperatura per evitare il rischio di incendio

Attenzione: pulire i mobili con un panno umido o alcol, evitare di utilizzare detersivi contenenti sostanze chimiche corrosive.

Attenzione: questo prodotto è dotato di un dispositivo antiribaltamento. Assicurarsi di installare questo dispositivo per prevenire lesioni inutili causate dal ribaltamento.

[ES]

Advertencia: Lea estas instrucciones completamente antes de comenzar el montaje. Compruebe que tiene todos los componentes y herramientas que se enumeran en las páginas. Conserve las instrucciones para consultarlas más adelante. El montaje de algunas partes será más sencillo con 2 personas. Busque ayuda profesional si es necesario.

Advertencia: Coloque todas las piezas sobre una superficie plana. Coloque una manta suave o algo similar debajo para protegerlas de rayones o manchas. Evite arrastrar o deslizar los componentes por el piso.

Advertencia: Verifique regularmente todos los accesorios y fijaciones para asegurarse de que estén seguros y evitar accidentes. Si falta alguna pieza, está rota, dañada o desgastada, deje de usar el producto hasta que se hayan realizado las reparaciones con piezas autorizadas de fábrica.

Advertencia: No permita que los niños se suban a los muebles, ya que esto puede provocar que se vuelquen y lesiones personales graves. Monte los muebles fuera del alcance de los niños.

Advertencia: No coloque los muebles cerca de fuentes de fuego u objetos de alta temperatura para evitar el riesgo de incendio.

Advertencia: Limpie los muebles con un paño húmedo o alcohol, evite usar agentes de limpieza que contengan químicos corrosivos.

Advertencia: Este producto está equipado con un dispositivo antivuelco. Asegúrese de instalar este dispositivo para evitar lesiones innecesarias causadas por vuelcos.

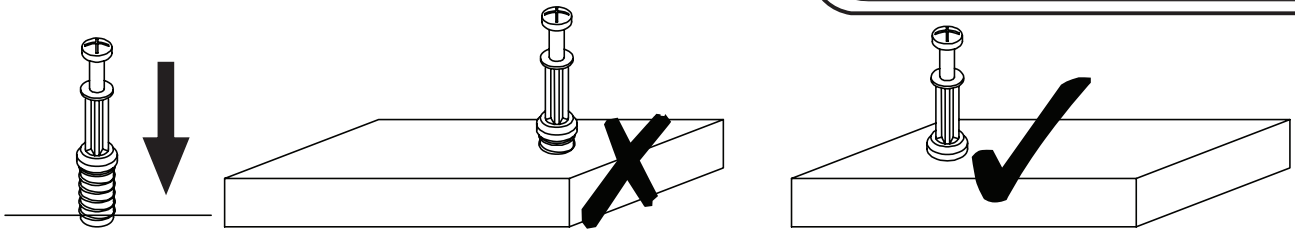

EN_QUICKFIT: Tighten quickfit until shoulder is flush with panel. Do not overtighten or undertighten.

FR_RACCORD RAPIDE: Faites serrer le raccord rapide jusqu'à ce que l'épaulement soit parfaitement encastré dans le panneau. Il ne faut ni trop serrer ni insuffisamment serrer.

ES_QUICKFIT: Apriete quickfit hasta que el hombro se descargue con el panel. NO lo sobreapriete ni lo apriete poco.

DE_QUICKFIT: Ziehen Sie den Quickfit fest, bis die Schulter mit der Platte bündig ist. Bitte nicht zu fest oder zu schwach anziehen.

IT_MONTAGGIO RAPIDO: Stringere il montaggio rapido fino a quando la spalla è a filo con il pannello, non stringere troppo o troppo poco.

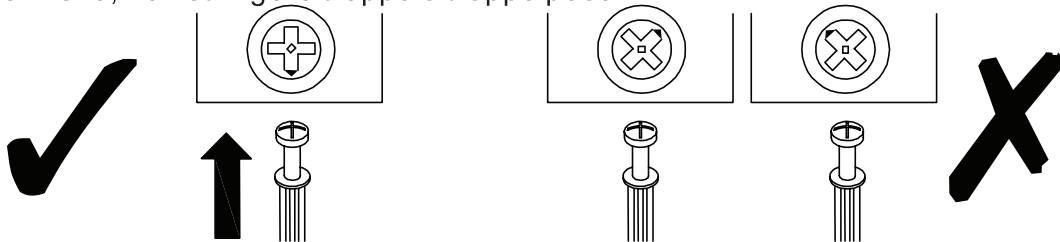

EN_CAM LOCK: When fitting cam lock, ensure starting position is correct before you insert connecting quickfit.

FR_SERRURE BATTEUSE: Avant d'insérer la serrure batteuse, veillez à la bonne orientation avant d'insérer le raccord rapide.

ES_CIERRE DE LA CÁMARA: Cuando instale el cierre de la cámara, asegúrese de que la posición de inicio es correcta antes de que inserte el quickfit conector.

DE_CAM-LOCK: Achten Sie bei der Montage des Cam-Locks auf die richtige Ausgangsposition, bevor Sie den Quickfit einsetzen.

IT_BLOCCAGGIO A CAMMA: Quando si monta il bloccaggio a camma, assicurarsi che la posizione iniziale sia corretta prima di inserire il montaggio rapido di collegamento.

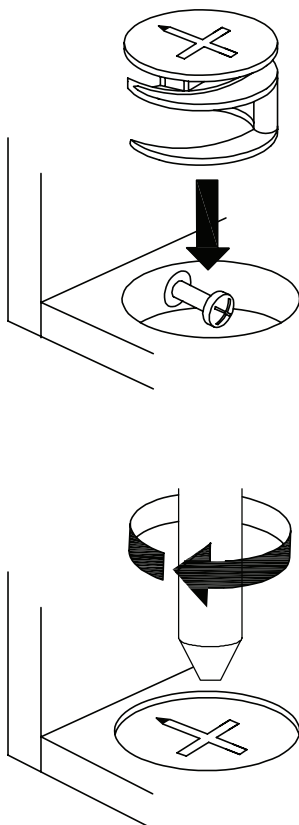

EN_Quickfit head should be in the centre of the cam lock when the two panels are joined.

Cam lock should be inserted before quickfit.

FR_Lorsque les deux panneaux sont assemblés, la tête du raccord rapide doit reposer au centre de la serrure batteuse. Il faut insérer la serrure batteuse avant le raccord rapide.

ES_El cabezal del quickfit debe estar en el centro del cierre de la cámara cuando se unan los dos paneles.

Se debe insertar el cierre de la cámara antes que el quickfit.

DE_Der Quickfit-Kopf sollte sich in der Mitte des Cam-Locks befinden, wenn die beiden Platten zusammengefügt sind. Der Cam-Lock sollte vor dem Quickfit eingesetzt werden.

IT_La testa del montaggio rapido deve trovarsi al centro del bloccaggio a camma quando i due pannelli sono uniti.

Il Bloccaggio a Camma deve essere inserito prima del montaggio rapido.

EN_Turn cam lock clockwise to tighten.

FR_Faites tourner la serrure batteuse dans le sens des aiguilles d'une montre pour la resserrer.

ES_Gire el cierre de la cámara en sentido horario para apretarlo.

DE_Drehen Sie den Cam-Lock im Uhrzeigersinn, um ihn festzuziehen.

IT_Ruotare il bloccaggio a camma in senso orario per stringere.

EN It may be necessary to adjust the hinges so that the doors align. Use the instructions below as a guide.

FR Il est parfois nécessaire d'ajuster les charnières pour un meilleur alignement des portes. Servez-vous des instructions ci-dessous comme guide.

ES Puede que sea necesario ajustar los quicios de forma que se alineen las puertas. Use las instrucciones que aparecen debajo como guía.

DE Möglicherweise müssen Sie die Scharniere so einstellen, dass die Türen ausgerichtet sind. Verwenden Sie die nachstehenden Anweisungen als Leitfaden.

IT Potrebbe essere necessario regolare le cerniere in modo che le porte siano allineate. Per fare ciò attenersi alle istruzioni sottostanti.

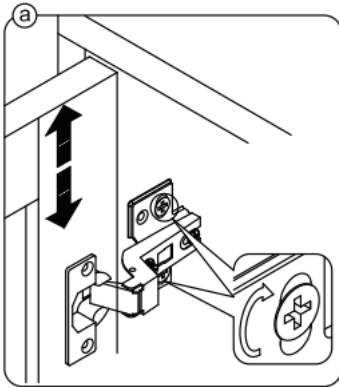

EN To adjust the door vertically loosen the screw as shown and move up and down as needed.

FR Si vous souhaitez régler la porte **verticalement**, desserrez la vis comme indiqué et déplacez la porte de haut en bas selon les besoins.

ES Para ajustar la puerta **verticalmente** afloje el tornillo tal y como se muestra y muévalo hacia arriba o hacia abajo según sea necesario.

DE Um die Tür **vertikal** auszurichten, lösen Sie die Schraube wie abgebildet und bewegen Sie sie nach Bedarf nach oben oder nach unten.

IT Per allineare la porta **verticalmente** allentare la vite come mostrato e spostarla in alto o in basso secondo necessità.

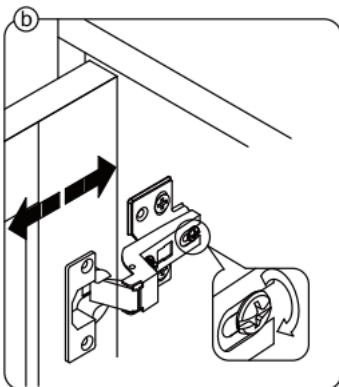

EN To adjust the gap from the door to the main frame turn the screw clockwise or anti-clockwise as needed.

FR Si vous souhaitez ajuster l'**écart** entre la porte et le cadre principal, tournez la vis dans le sens des aiguilles d'une montre ou dans le sens inverse, si nécessaire.

ES Para ajustar el **espacio** desde la puerta al marco principal, gire el tornillo en sentido horario o antihorario según se necesite.

DE Um den **Abstand** von der Tür zum Hauptrahmen auszurichten, drehen Sie die Schraube je nach Bedarf im oder gegen den Uhrzeigersinn.

IT Per regolare lo **spazio** tra la porta e il telaio principale, avvitare o svitare la vite secondo necessità.

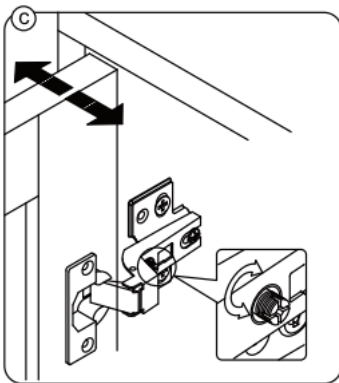

EN To adjust the door laterally adjust the screw as shown by turning clockwise or anti-clockwise.

FR Si vous souhaitez ajuster la porte **latéralement**, ajustez la vis comme indiqué en tournant dans le sens des aiguilles d'une montre ou dans le sens inverse des aiguilles d'une montre.

ES Para ajustar la puerta **lateralmente** ajuste el tornillo tal y como se muestra girándolo en sentido horario y antihorario.

DE Um die Tür **seitlich** auszurichten, stellen Sie bitte die Schraube wie abgebildet durch Drehen im oder gegen den Uhrzeigersinn ein.

IT Per allineare la porta **lateralmente** regolare la vite come mostrato, avvitarandola o svitarandola

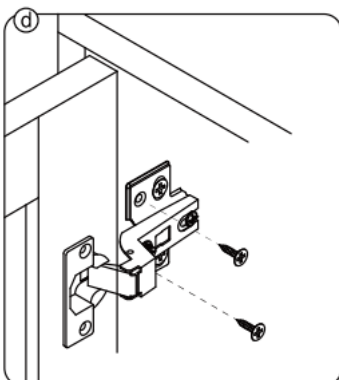

EN Please fix other screws

FR Merci de serrer les autres vis

ES Fije los demás tornillos

DE Befestigen Sie bitte die anderen Schrauben

IT Fissare le altre viti

GETTING TO KNOW YOUR PRODUCT

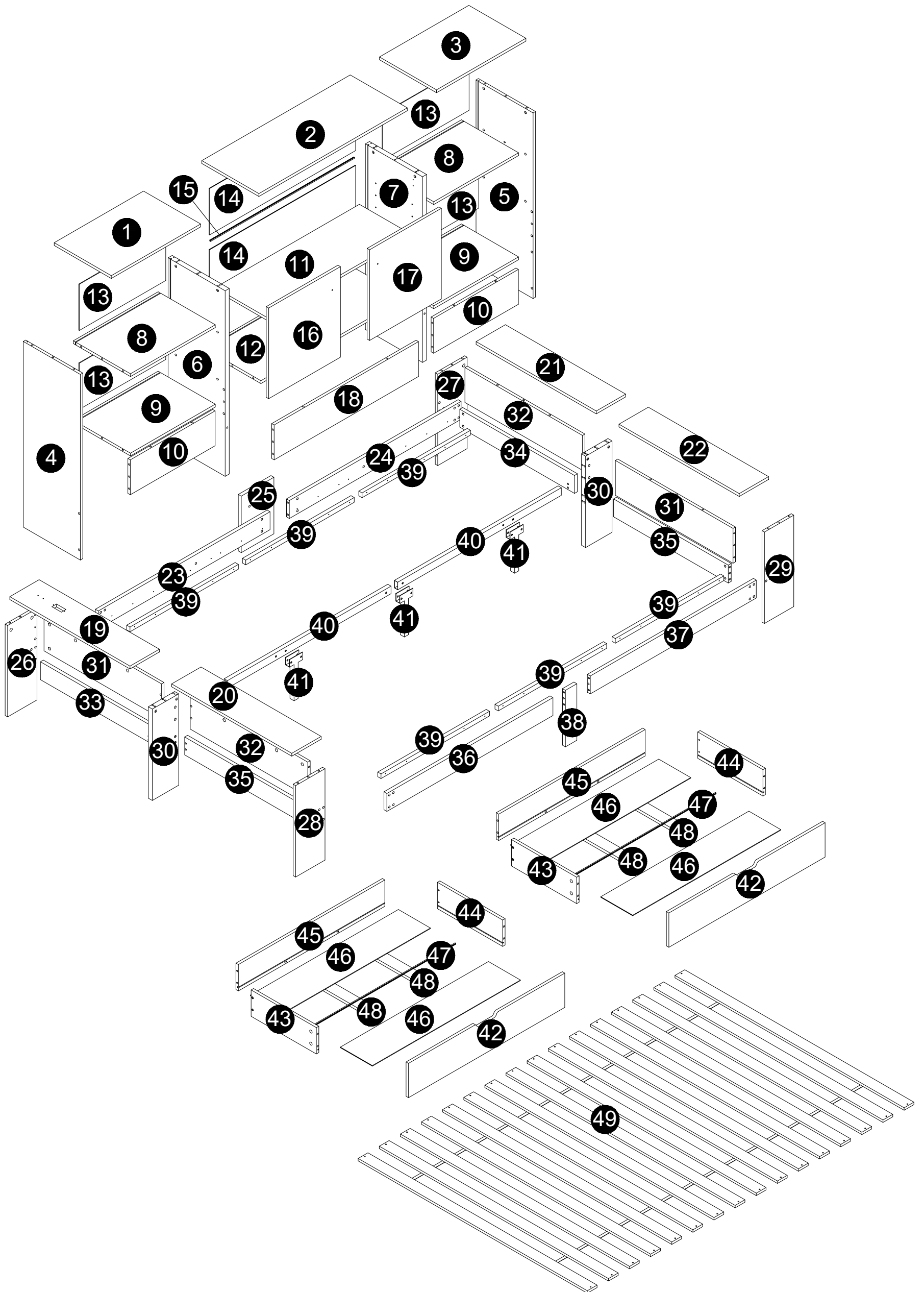

Part List/Teileliste/Liste des pieces N616P418441

1

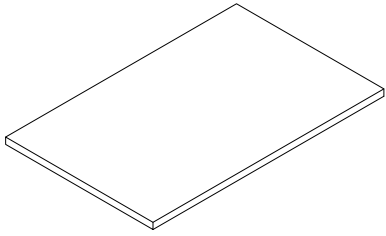

1PC

7

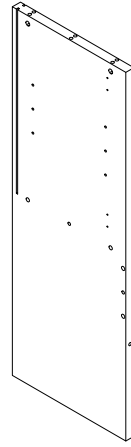

1PC

3

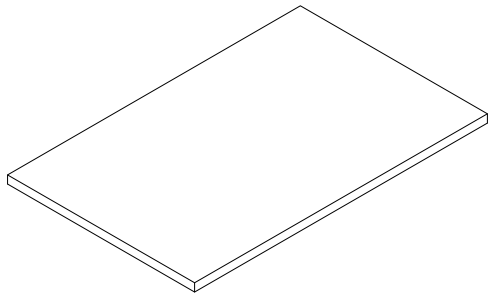

1PC

13

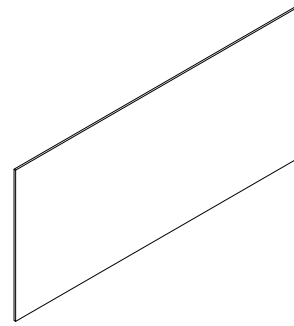

4PCS

4

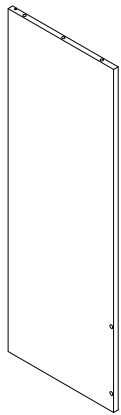

1PC

43

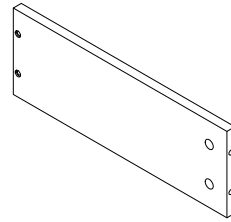

2PCS

5

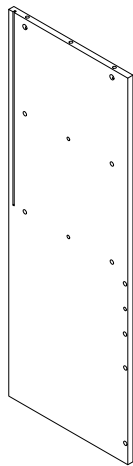

1PC

44

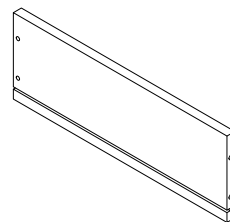

2PCS

6

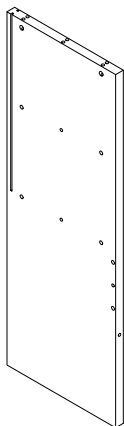

1PC

48

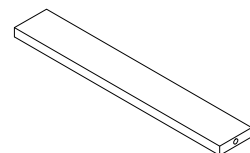

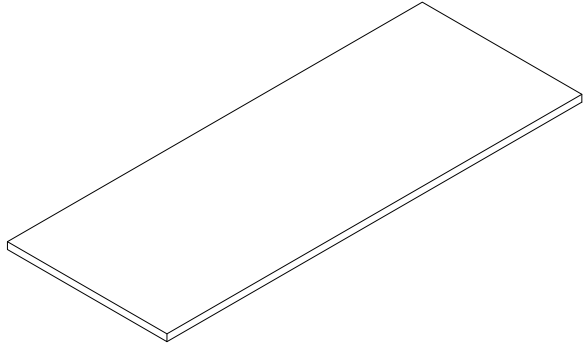
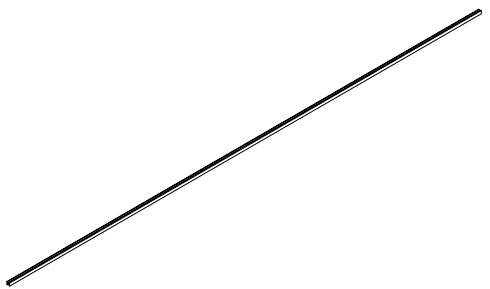
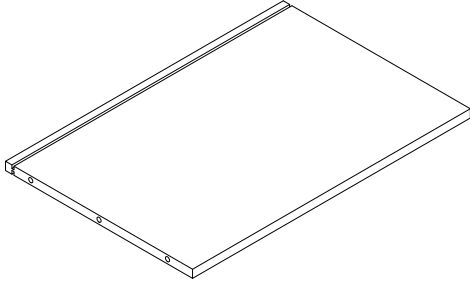
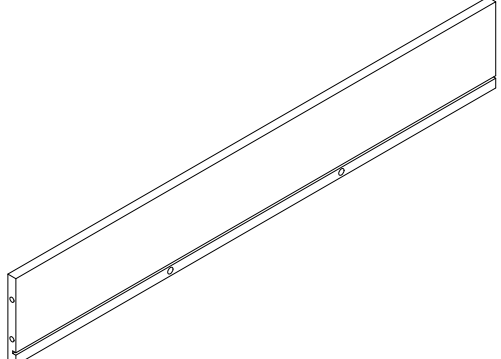
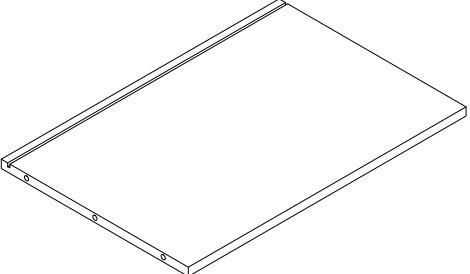
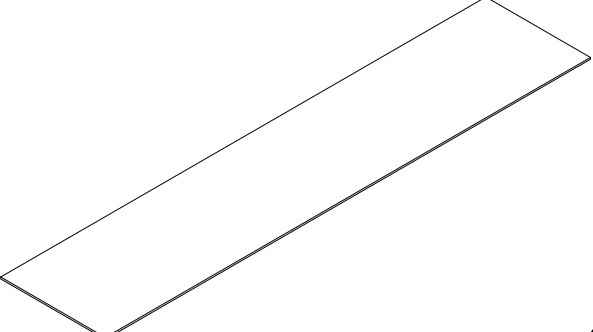
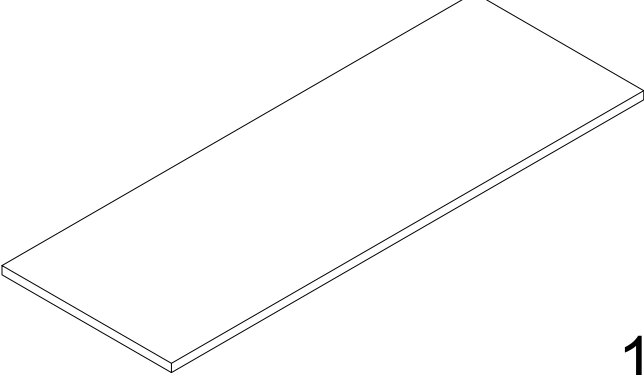
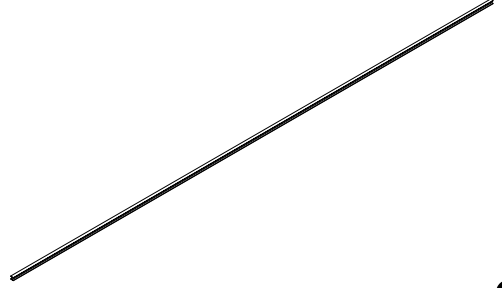
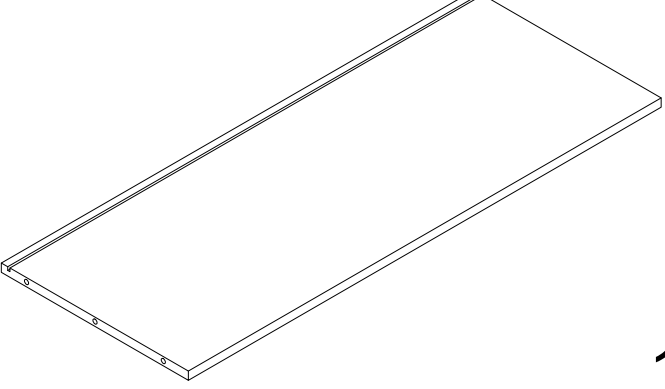
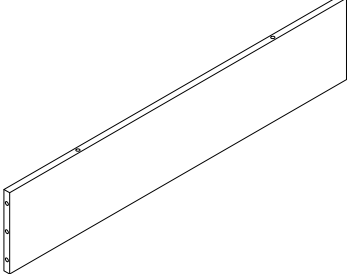
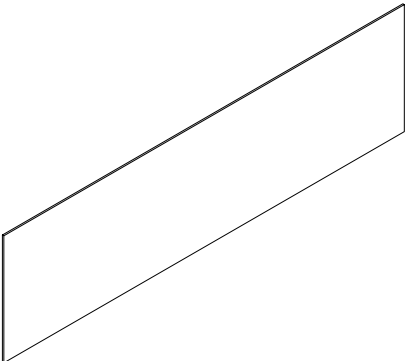
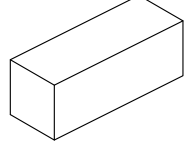

4PCS

Part List/Teileliste/Liste des pieces N616P418442

<p>2</p>  <p>1PC</p>	<p>15</p>  <p>1PC</p>
<p>8</p>  <p>2PCS</p>	<p>45</p>  <p>2PCS</p>
<p>9</p>  <p>2PCS</p>	<p>46</p>  <p>4PCS</p>
<p>11</p>  <p>1PC</p>	<p>47</p>  <p>2PCS</p>
<p>12</p>  <p>1PC</p>	<p>18</p>  <p>1PC</p>
<p>14</p>  <p>2PCS</p>	<p>Hardware</p> 

Part List/Teileliste/Liste des pieces

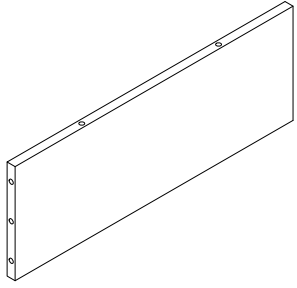
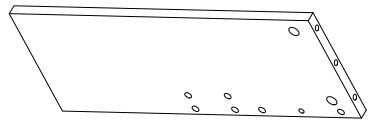
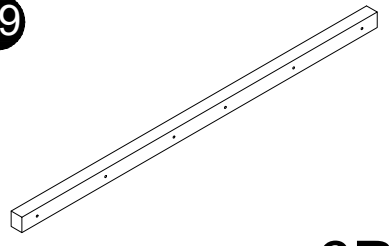
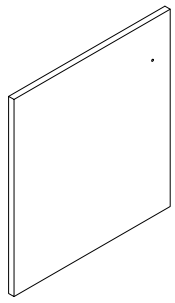
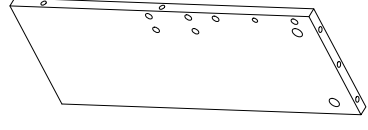
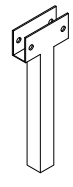
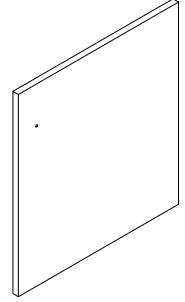
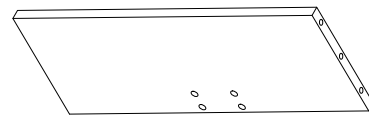
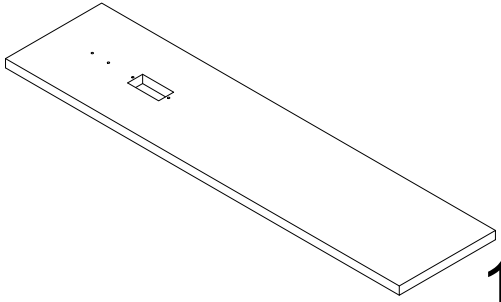
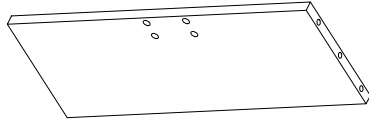
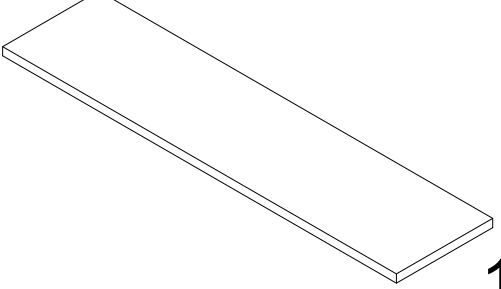
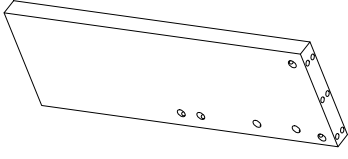
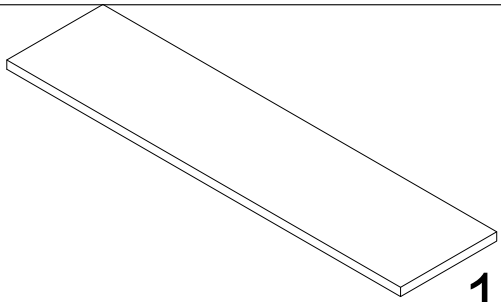
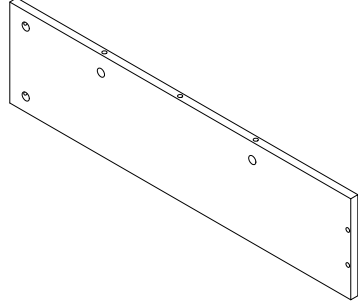
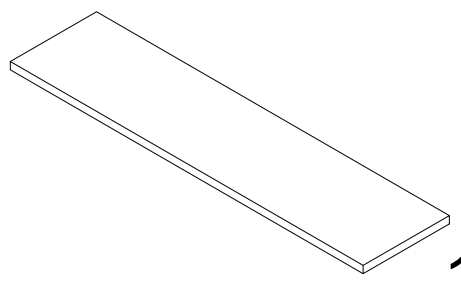
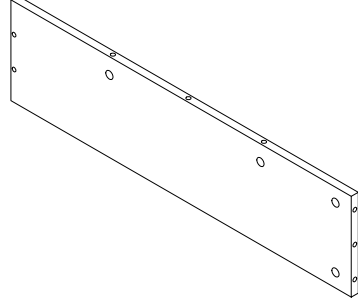
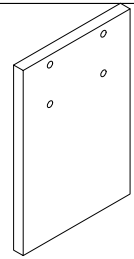
N616P418443

10  2PCS	26  1PC	39  6PCS
16  1PC	27  1PC	41  3PCS
17  1PC	28  1PC	
19  1PC	29  1PC	
20  1PC	30  2PCS	
21  1PC	31  2PCS	
22  1PC	32  2PCS	
25  1PC	38  1PC	

Part List/Teileliste/Liste des pieces N616P418444

23

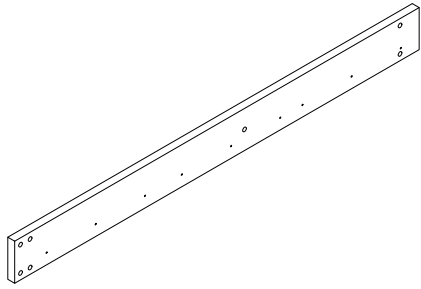

1PC

42

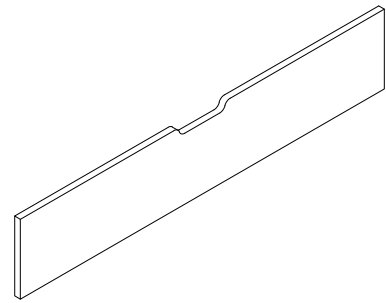

2PCS

24

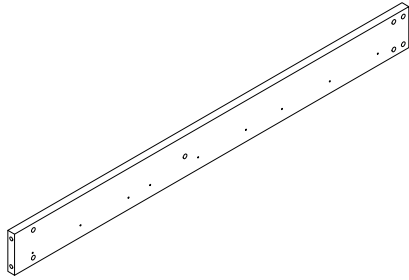

1PC

49

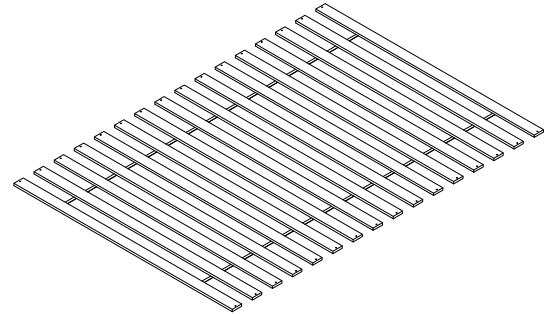

1PC

33

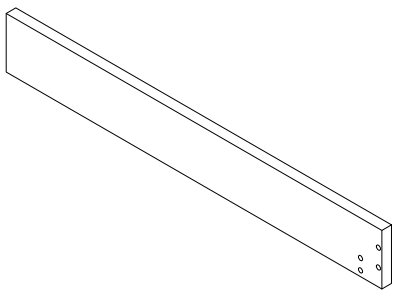

1PC

34

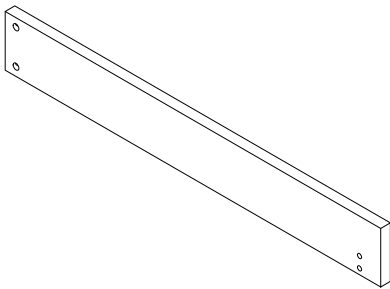

1PC

35

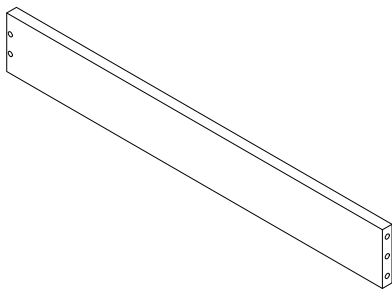

2PCS

36

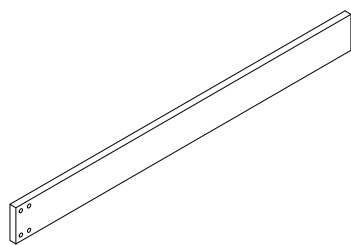

1PC

37

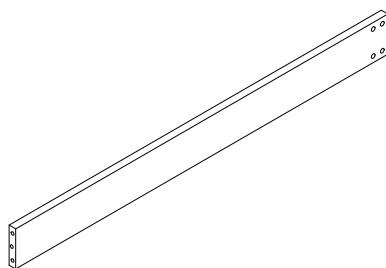

1PC

40

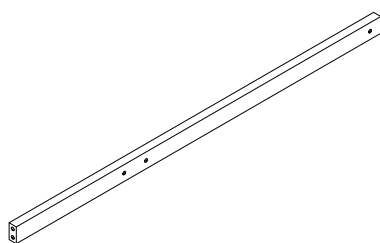

2PCS

Hardware List/ Hardware-Liste/Liste du matériel N616P418442

Ax82 	Kx44 4x30 	Ux4 	
Bx114 15*10 	Lx1  	Vx2     V1 V2 V3 V4	
Cx36 8x40 	Mx40 	Yx2   Y1 Y2	
Dx84 3.5x14 	Nx32 	Zx8  6x70 Z1  12mm Z2	
Ex1    E1 E2 E3	Px8 6x30 	AAx22 	
Fx6 	Qx32 3x30 	ABx8 	
Gx18  15mm	Rx1 6*130mm     R1*2 R2*2 R4*2	ACx4 	
Hx10 6x20 	Sx3 	ADx8 6x25 	
Jx6 7x50 	Tx2 M4 	AEx4 	AFx4 6x40 

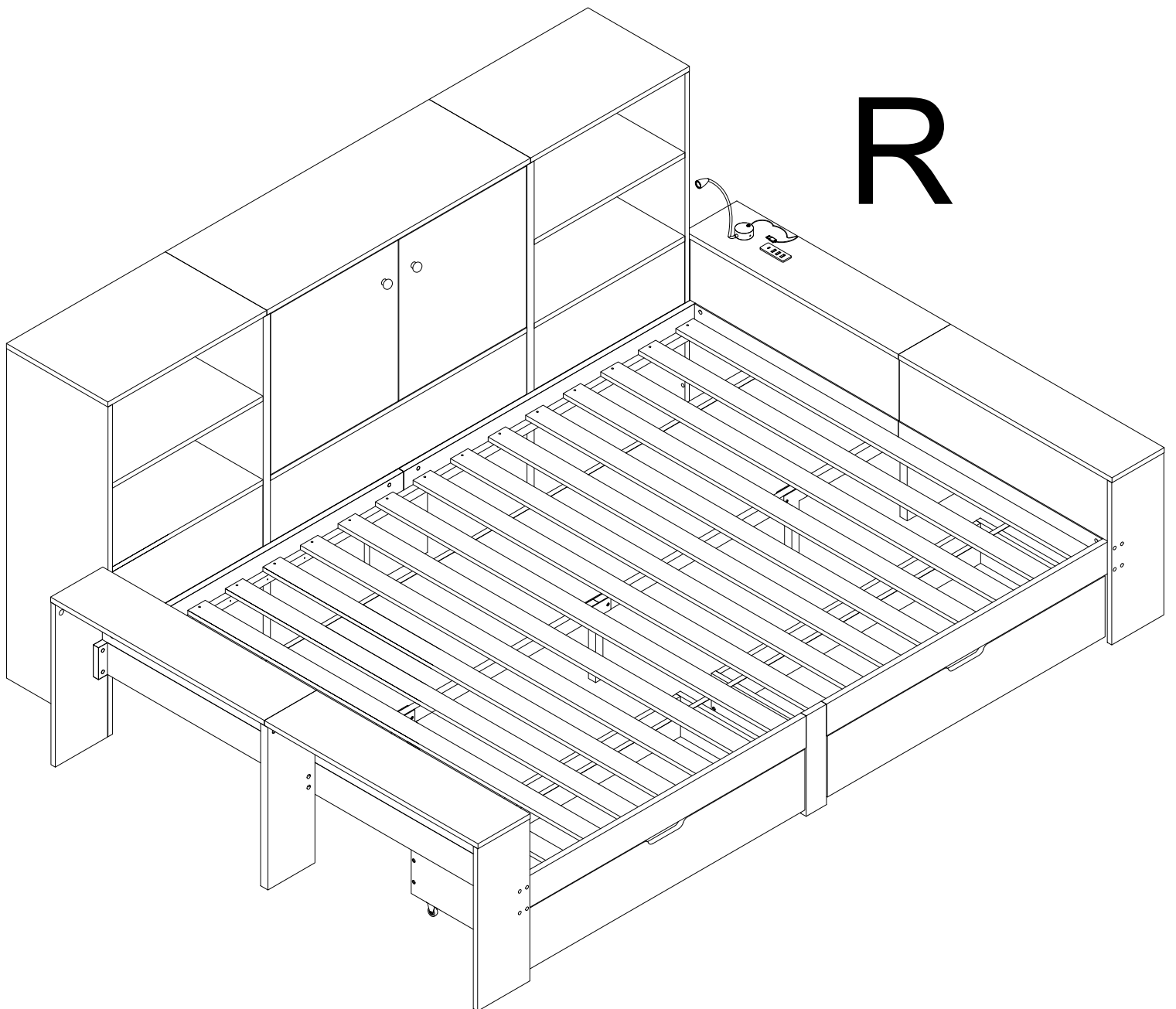
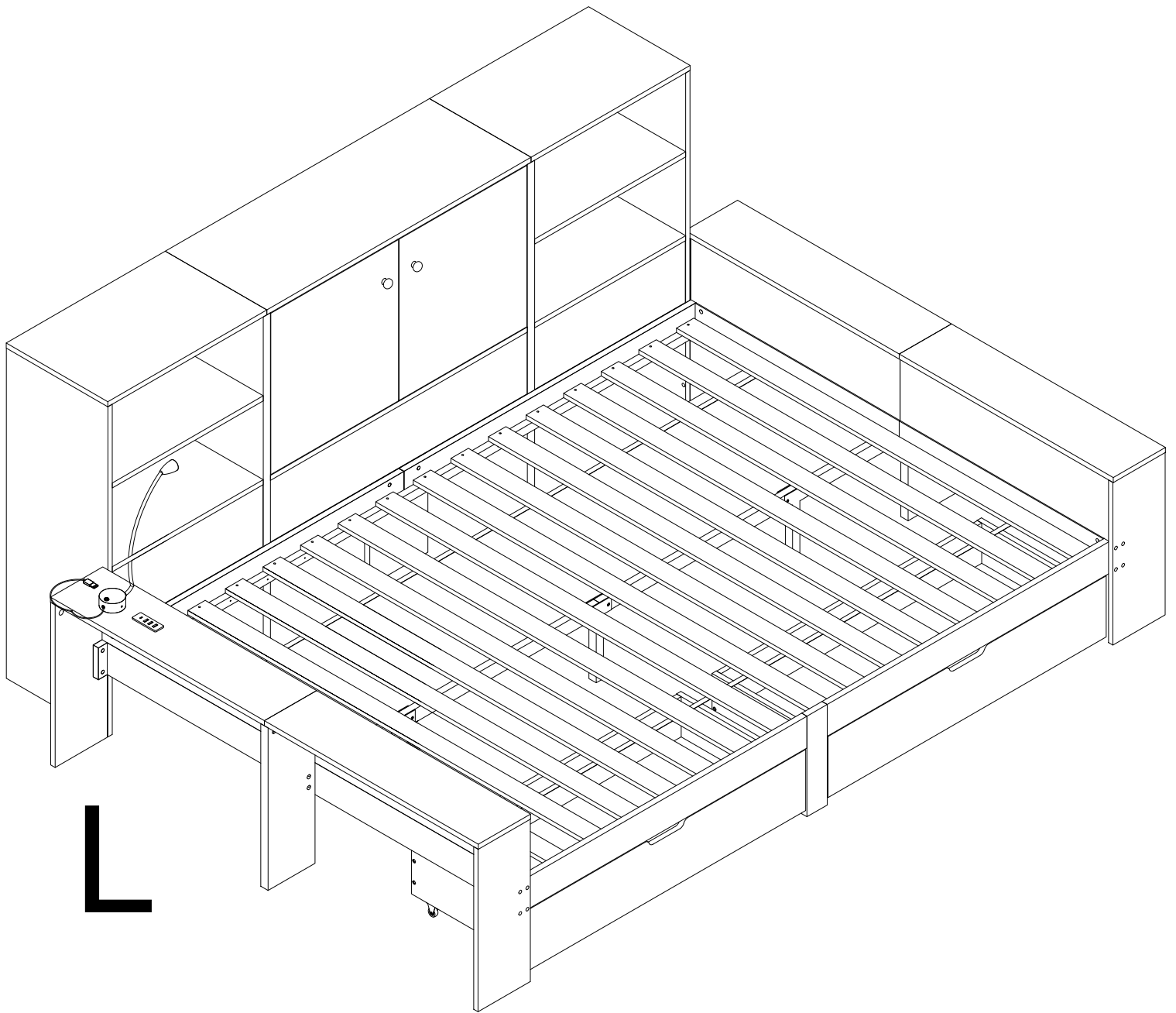

1

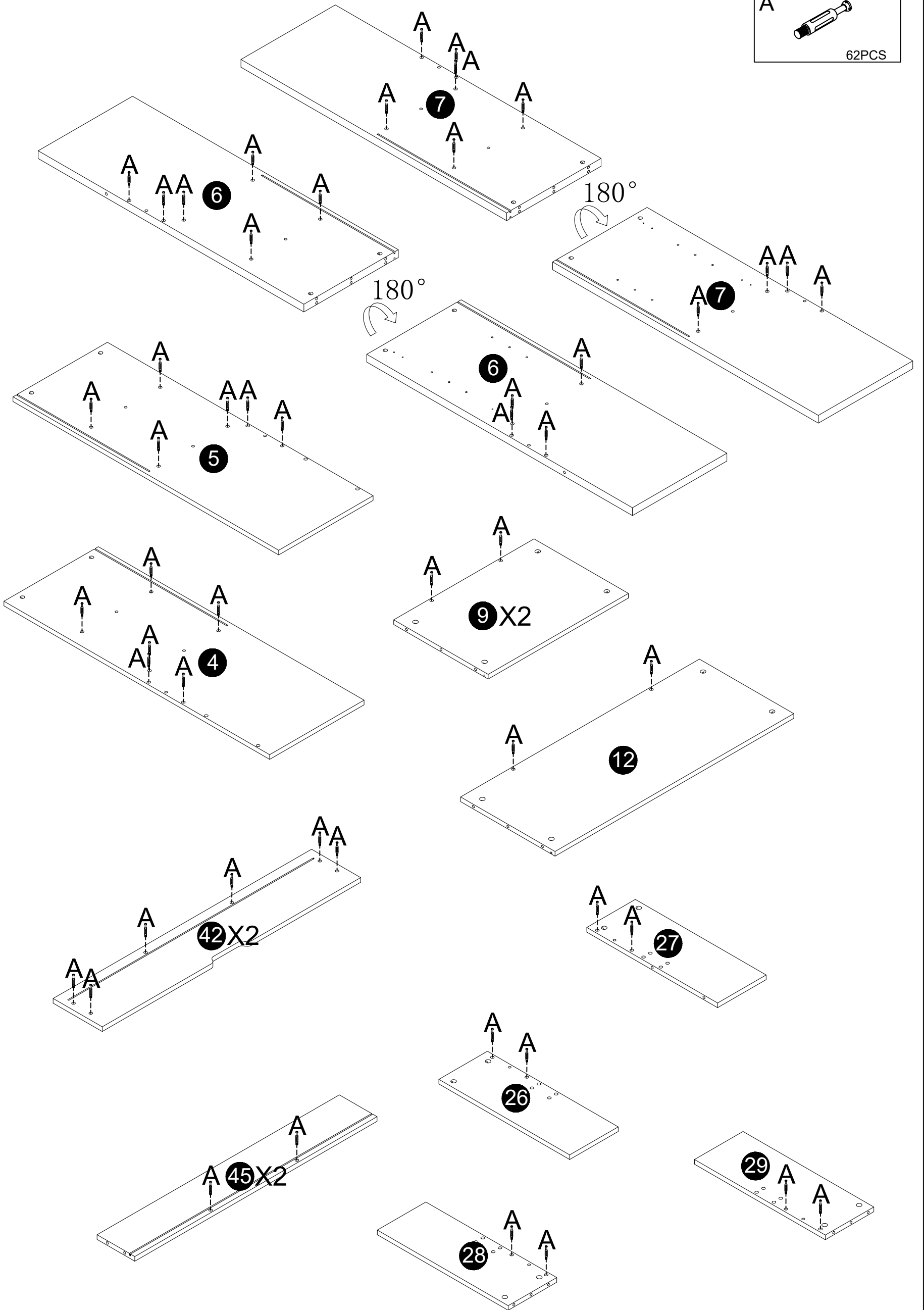
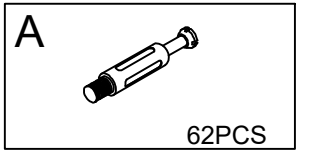

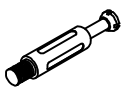
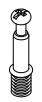

2

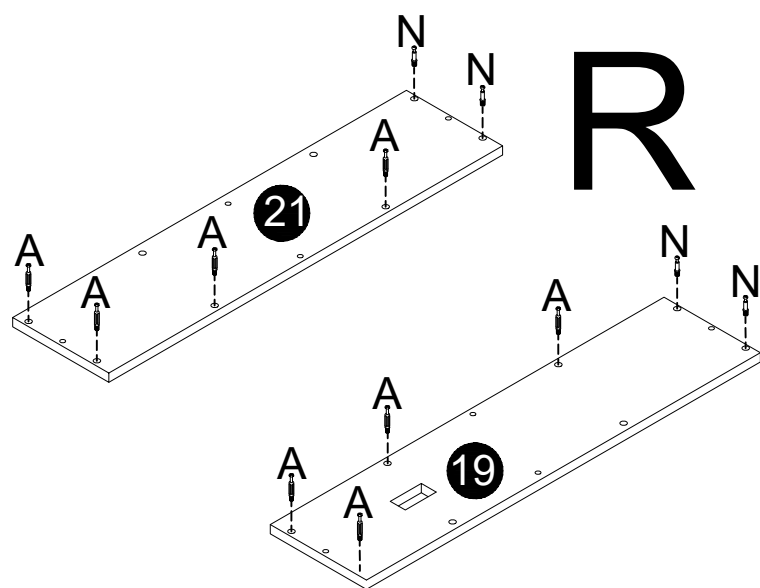
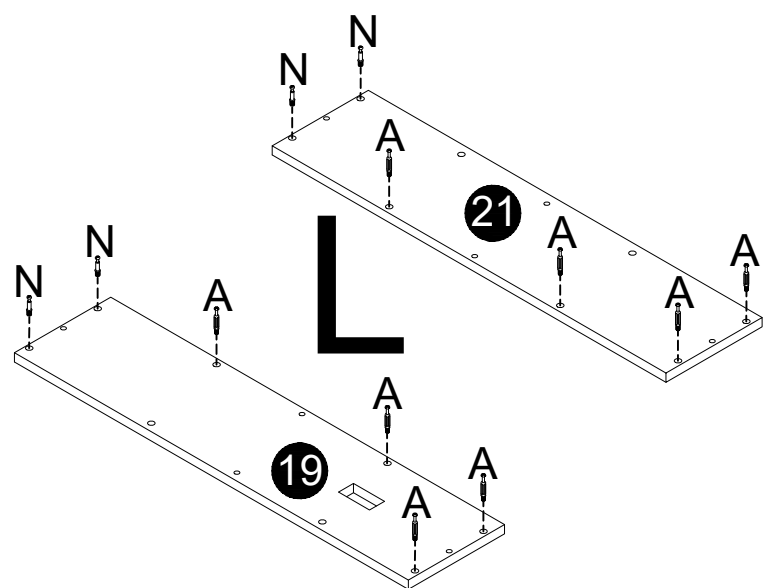
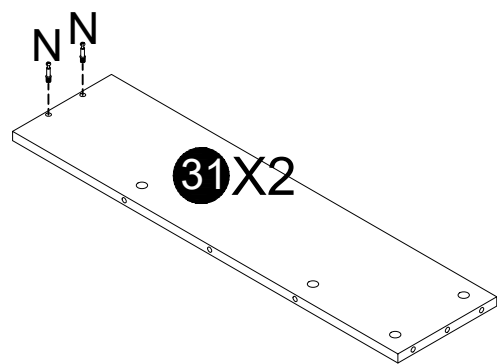
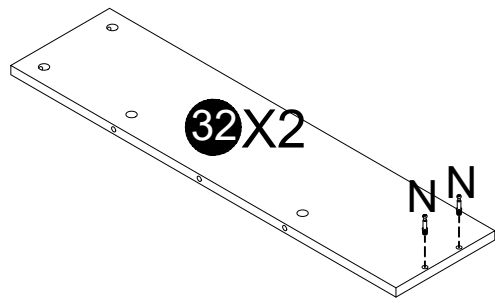
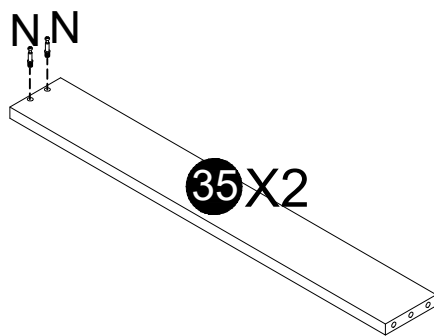
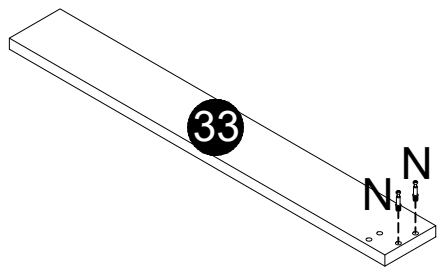
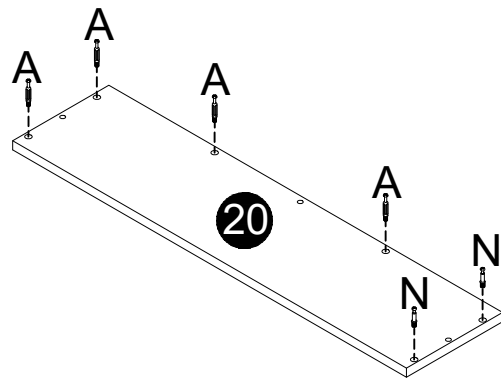
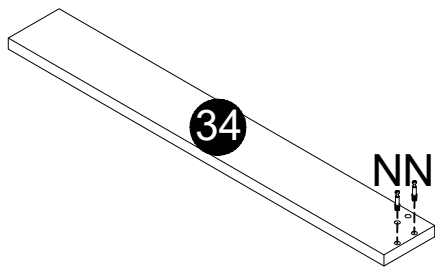
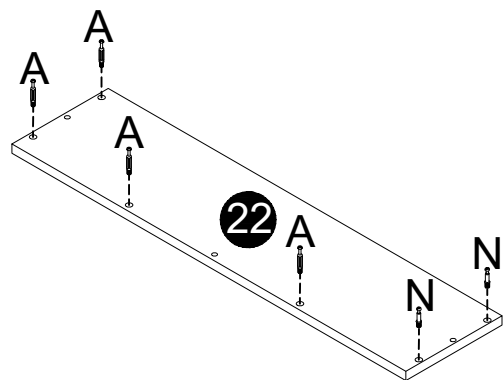
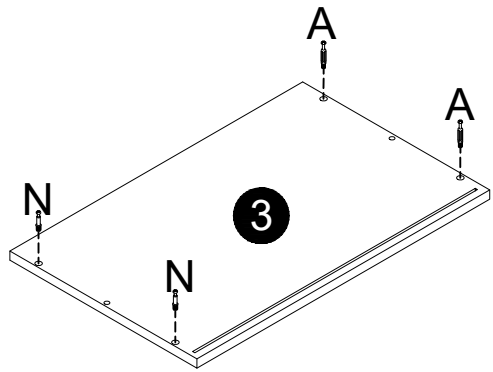
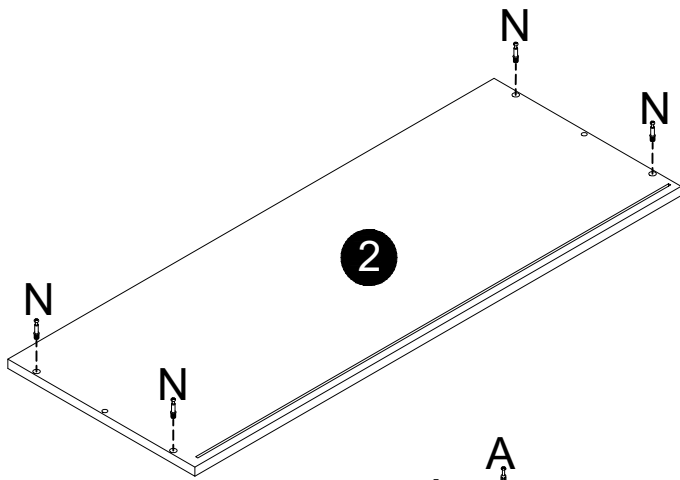
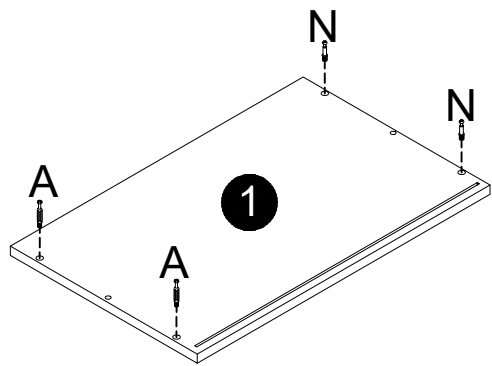
A		20PCS
N		32PCS

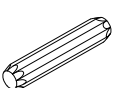

3

C		8*40
		36PCS
P		6*30
		8PCS

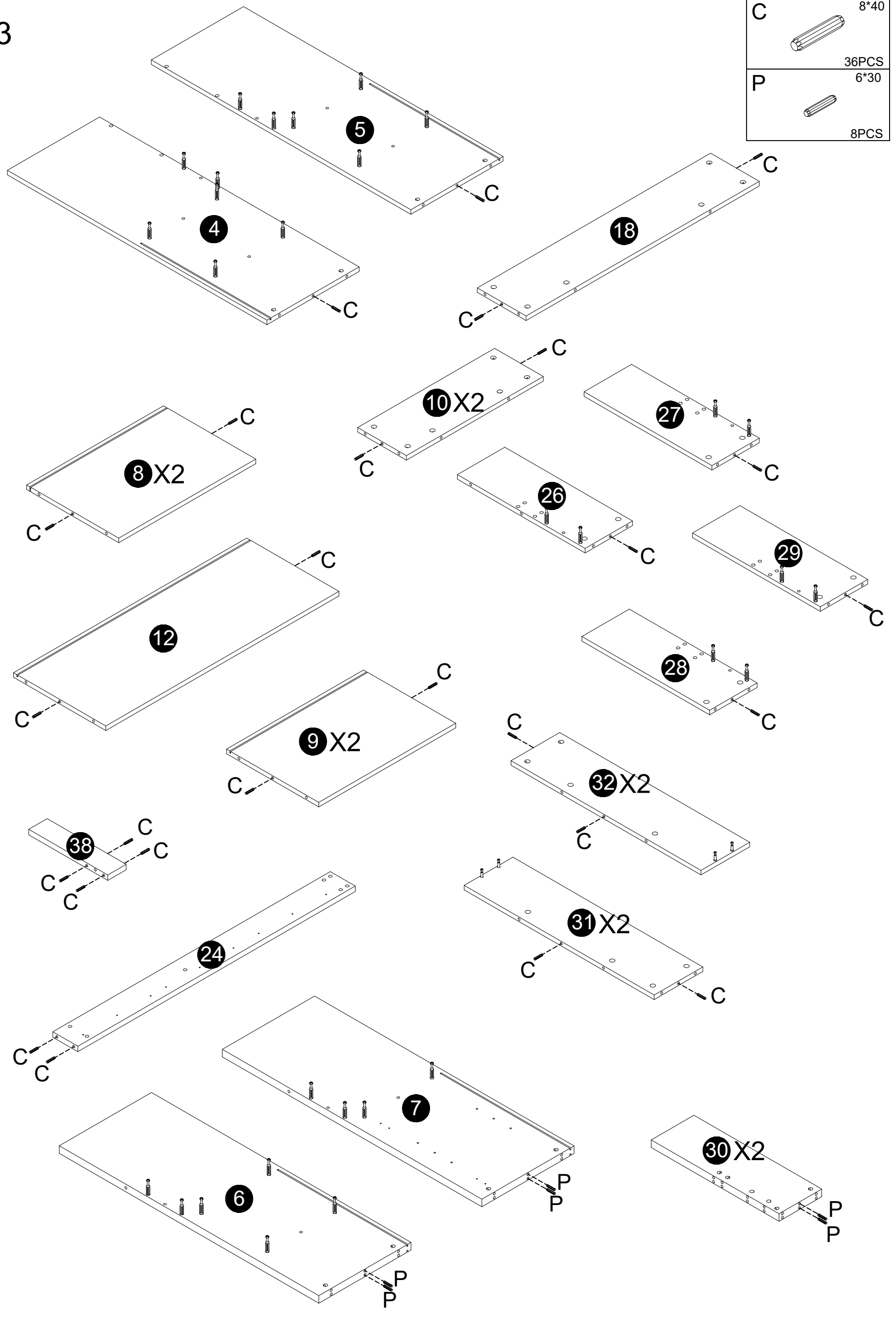

4

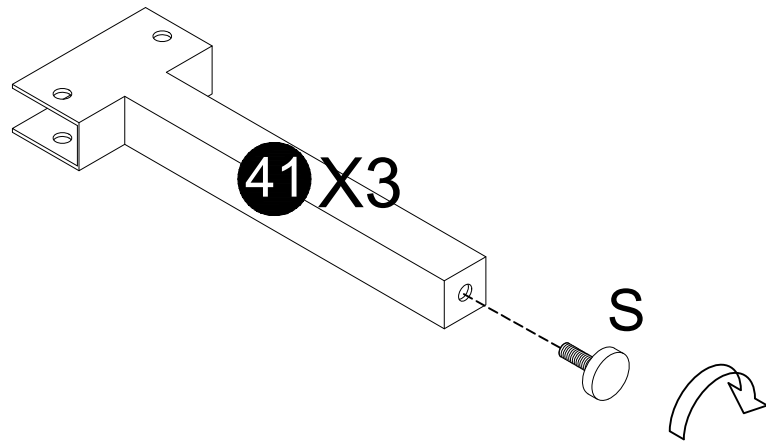
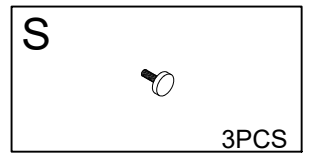

5

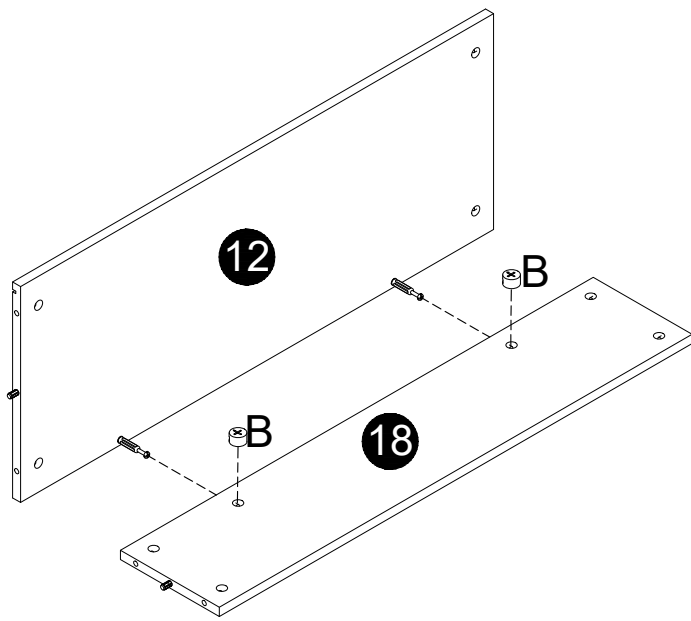
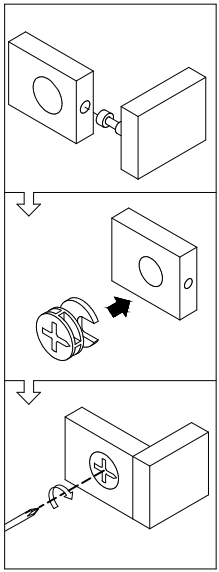
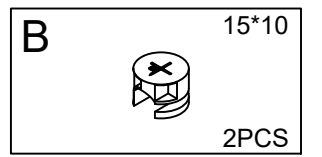

6

B 15*10
8PCS

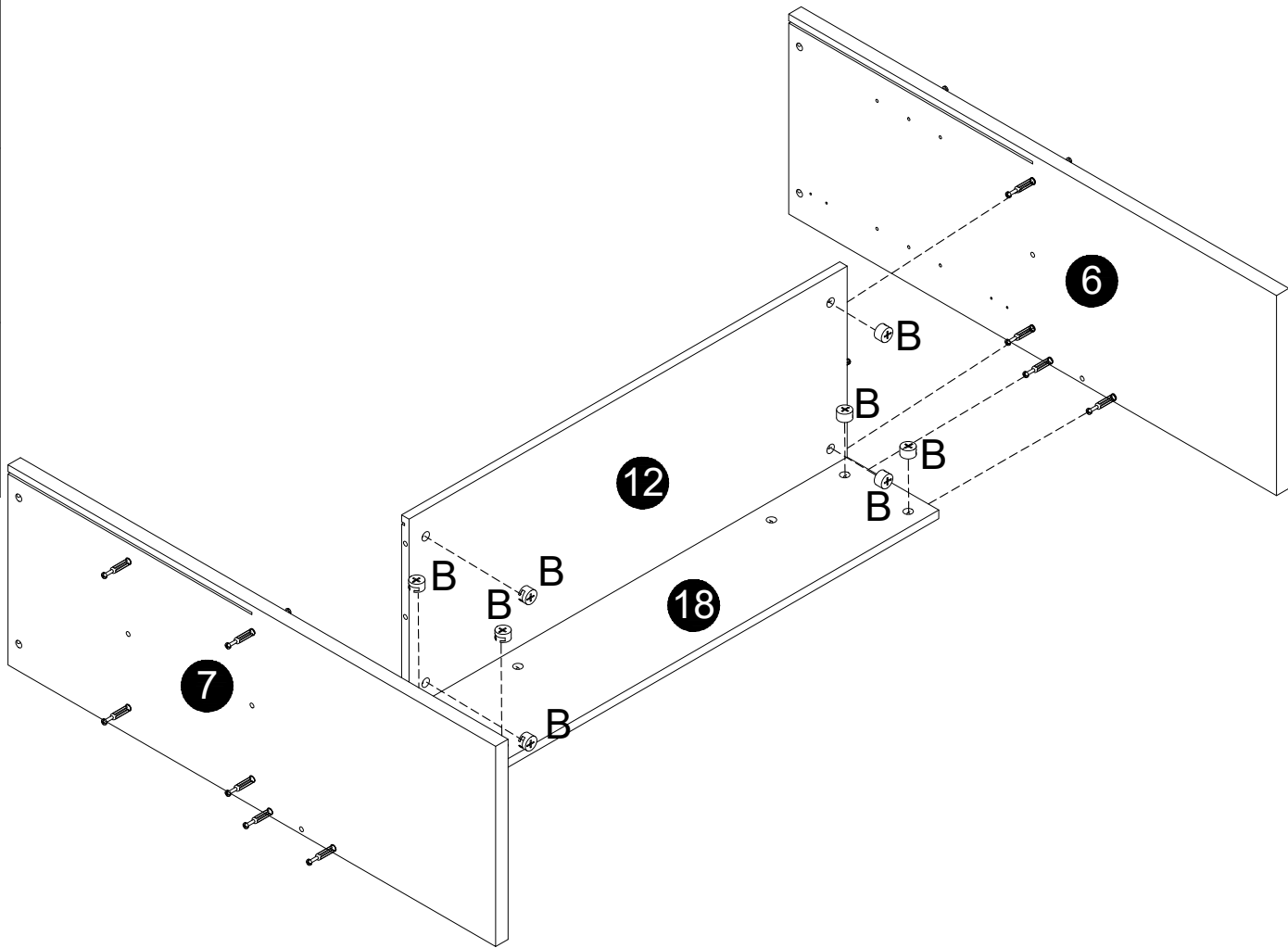
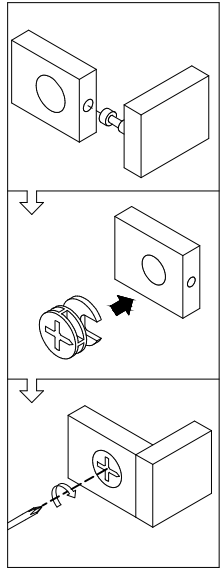

7

B 15*10
4PCS

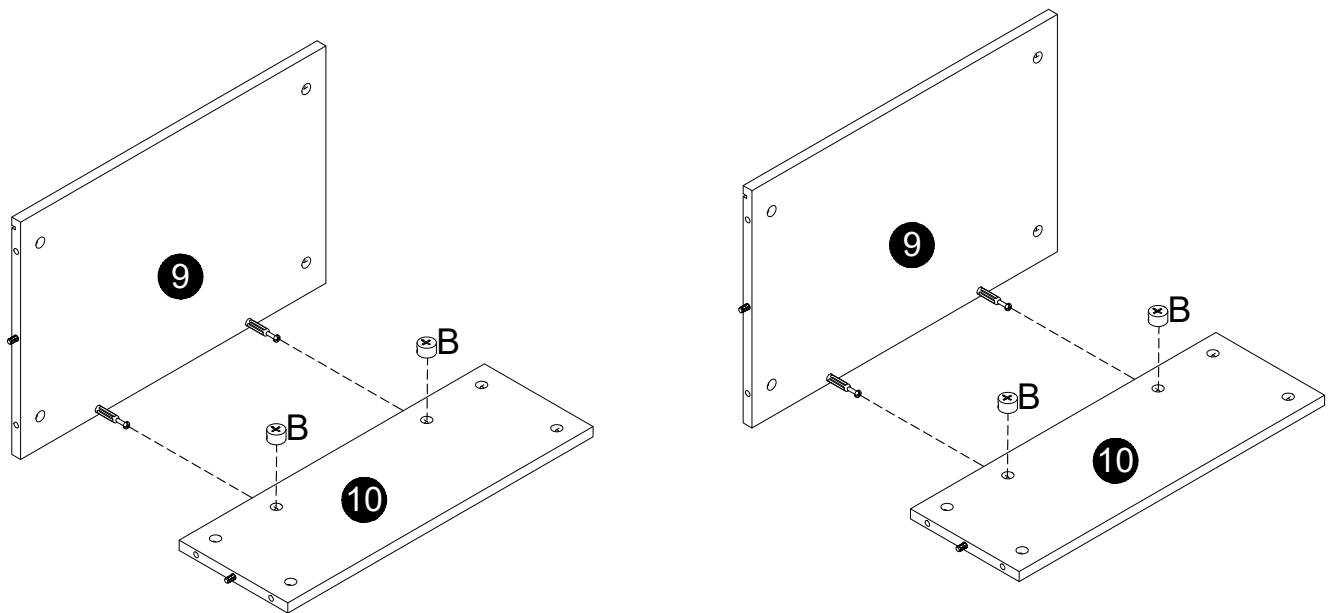
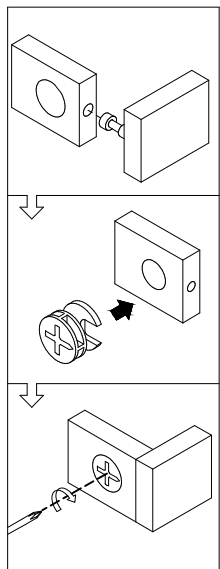

8

B 15*10
12PCS

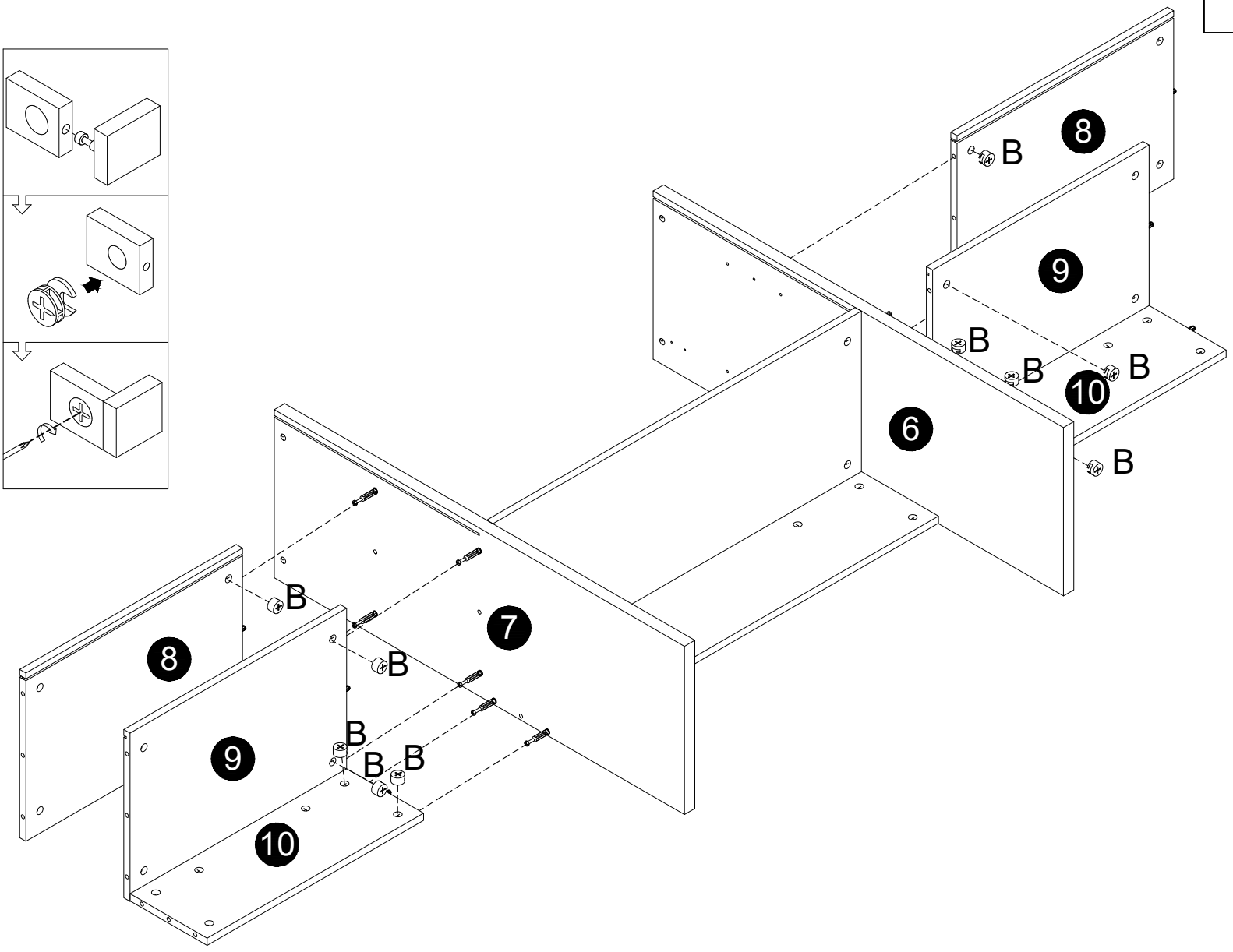
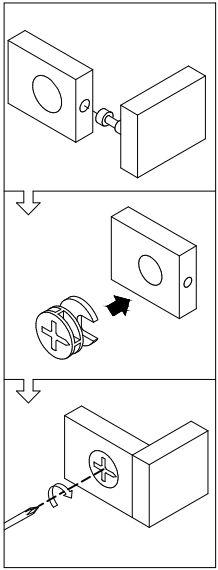

9

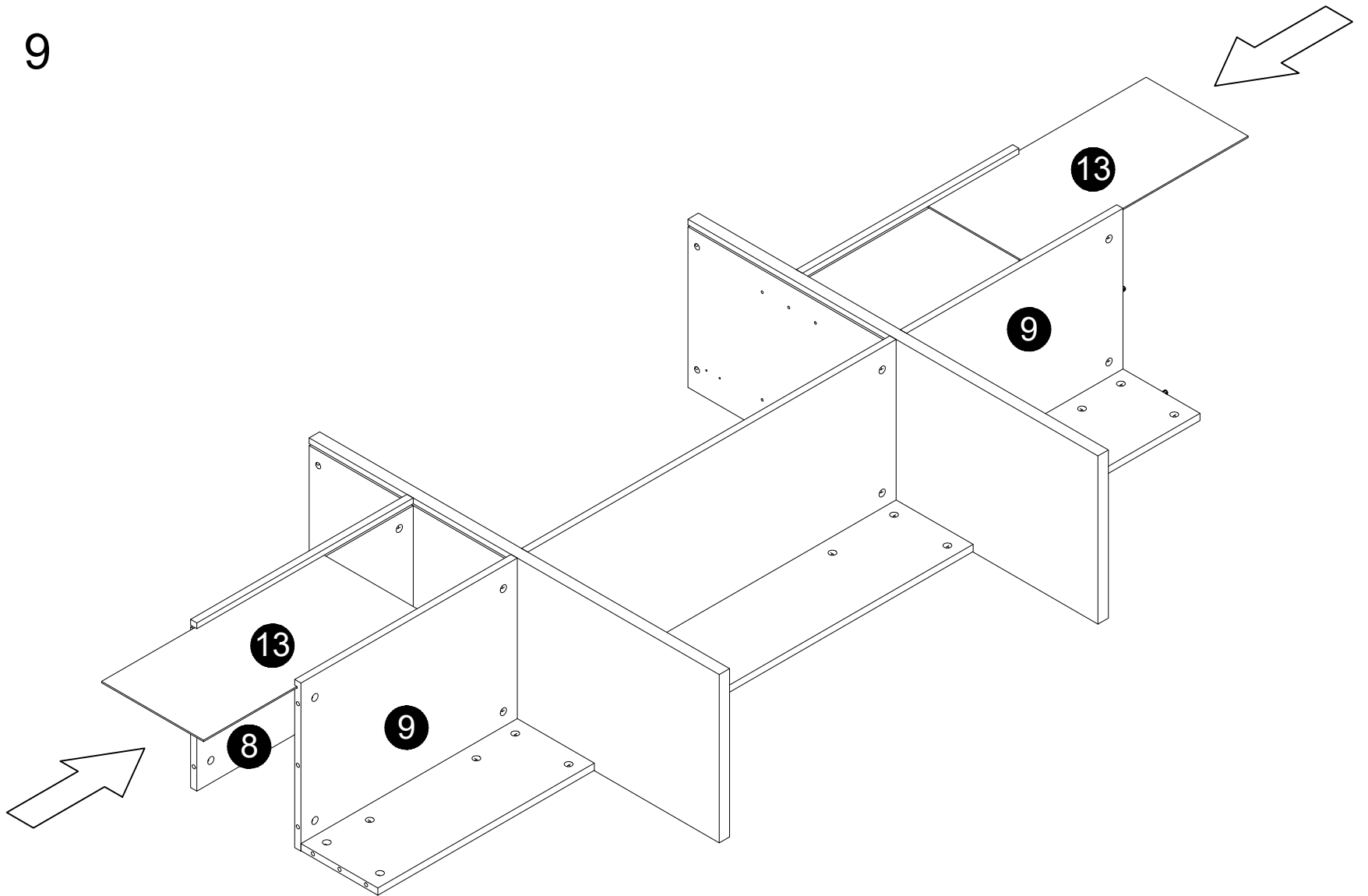

10

B 15*10
12PCS

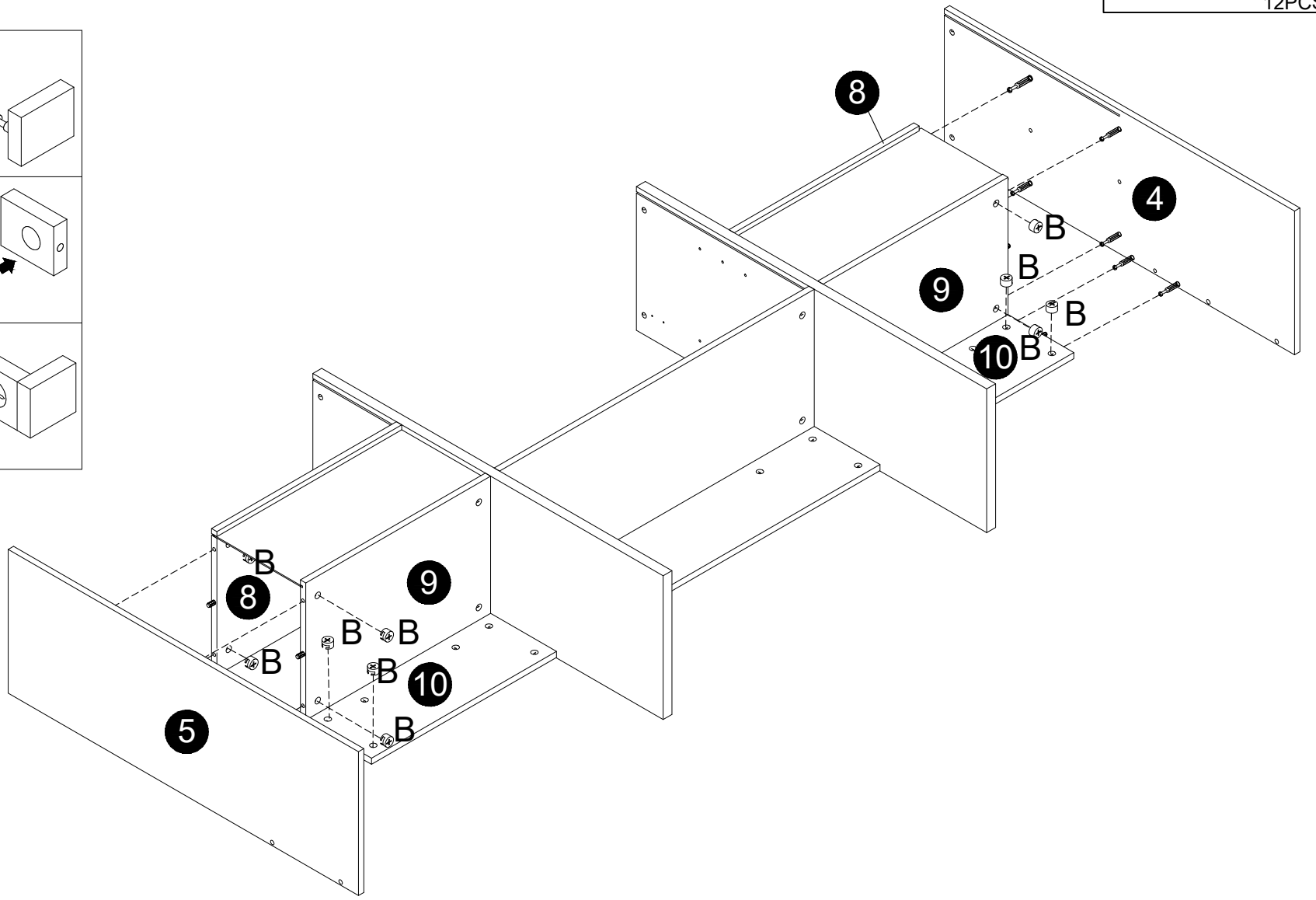
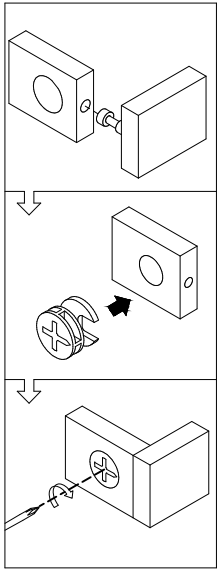

11

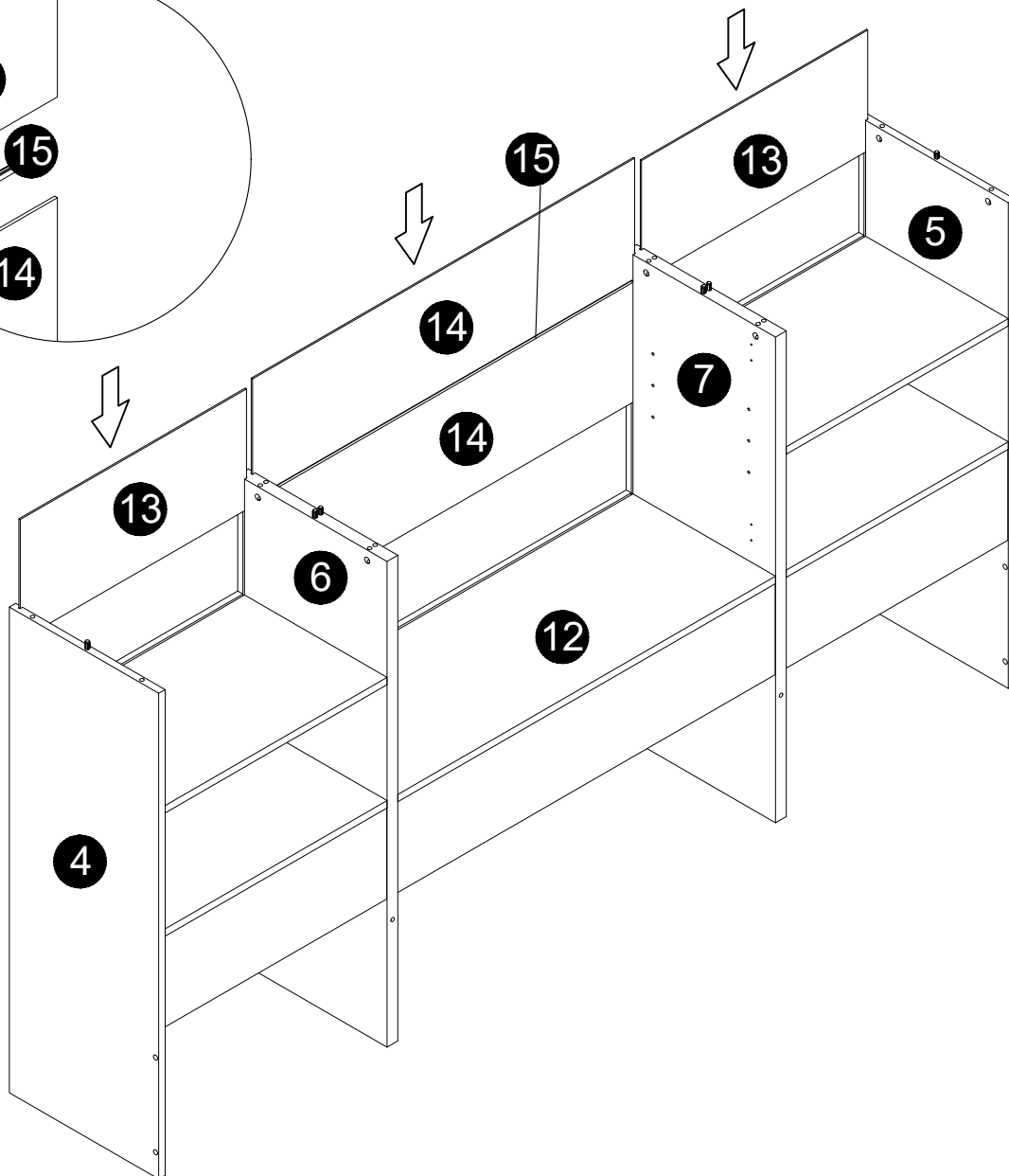
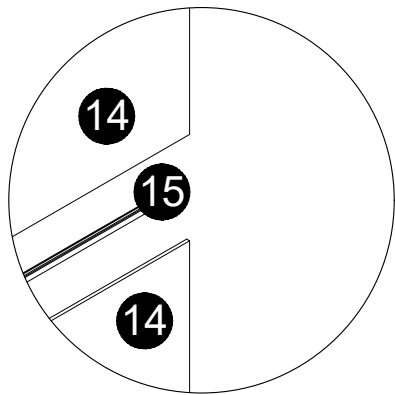

12

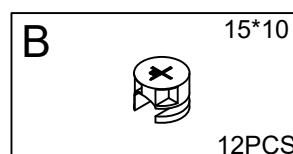
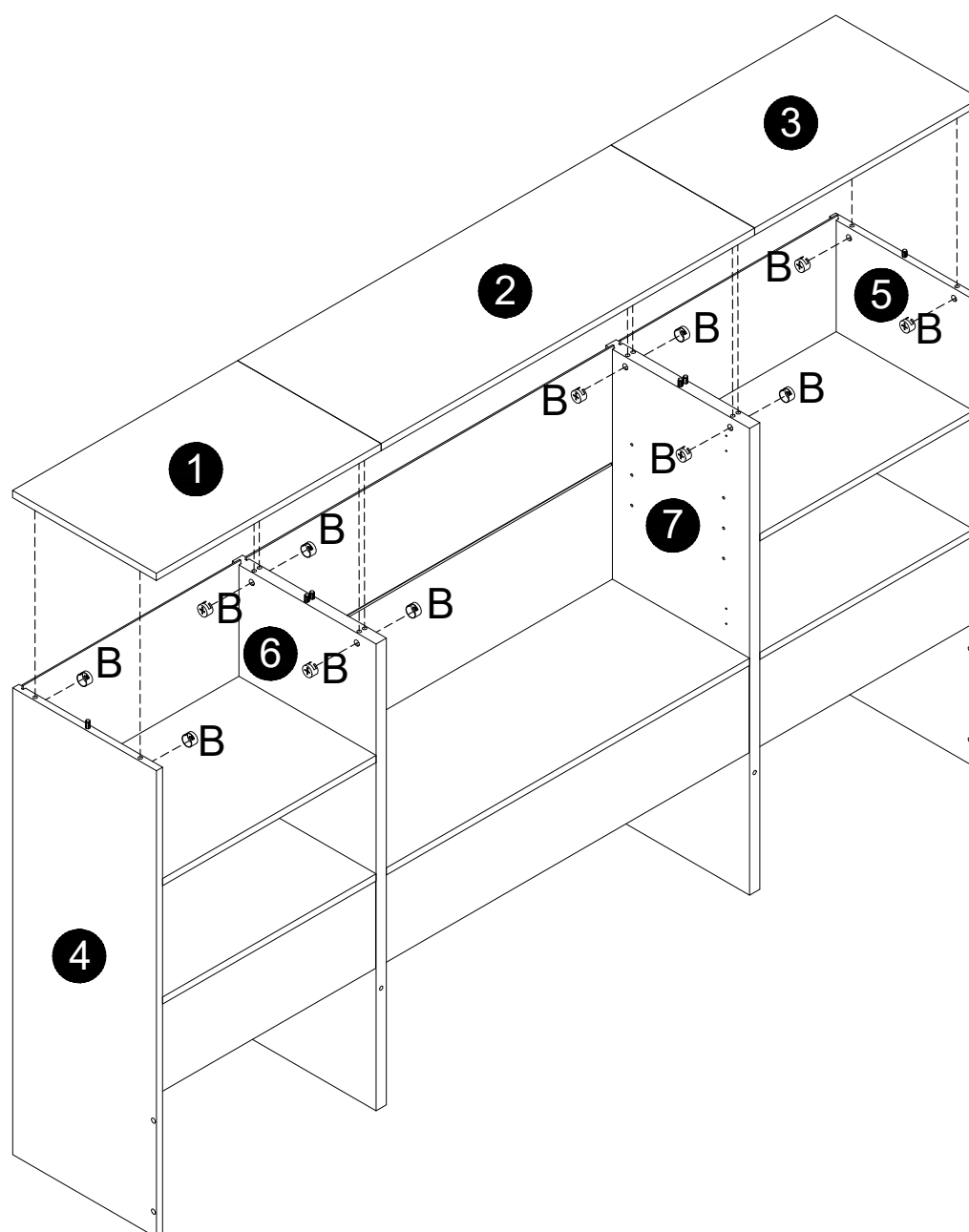
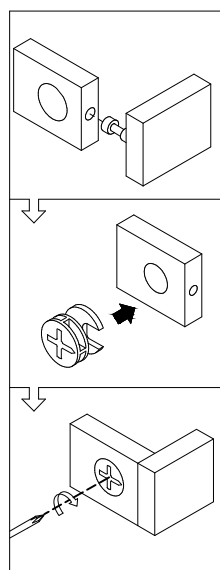

13

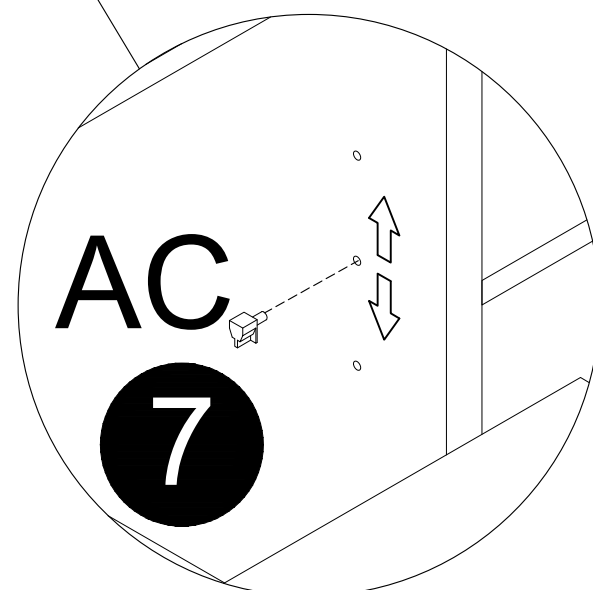
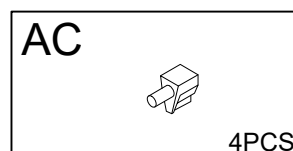
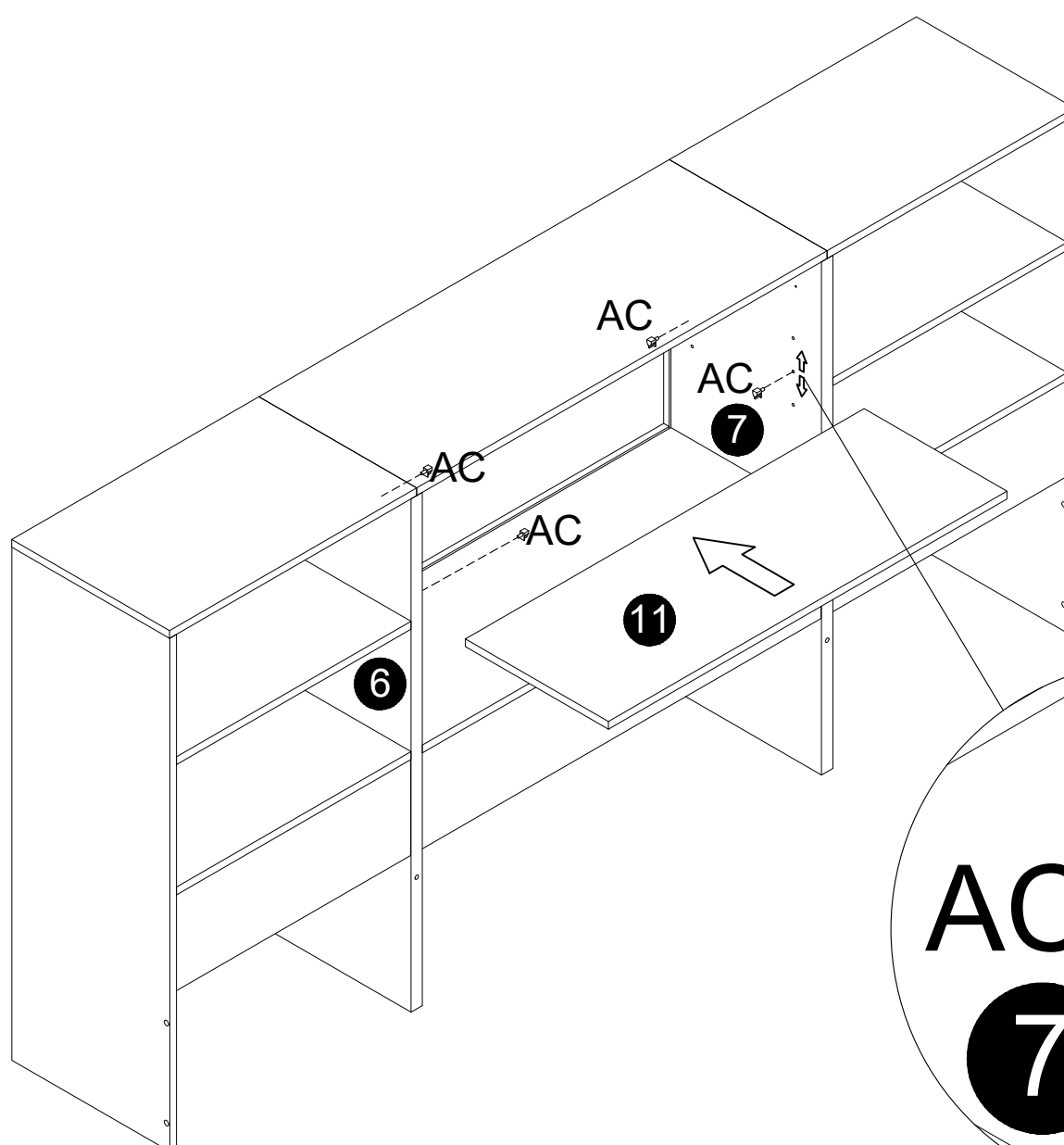

14

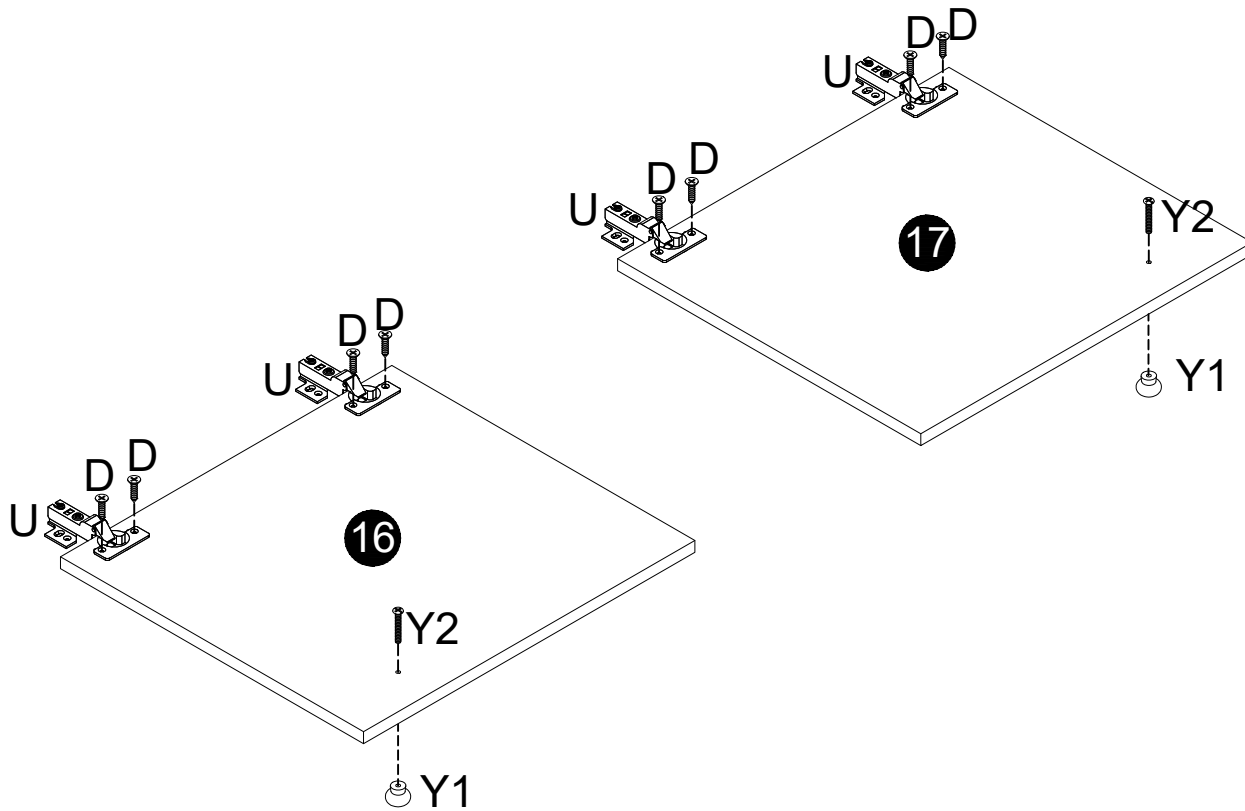

D		8PCS
U		4PCS
Y	 	2PCS

15

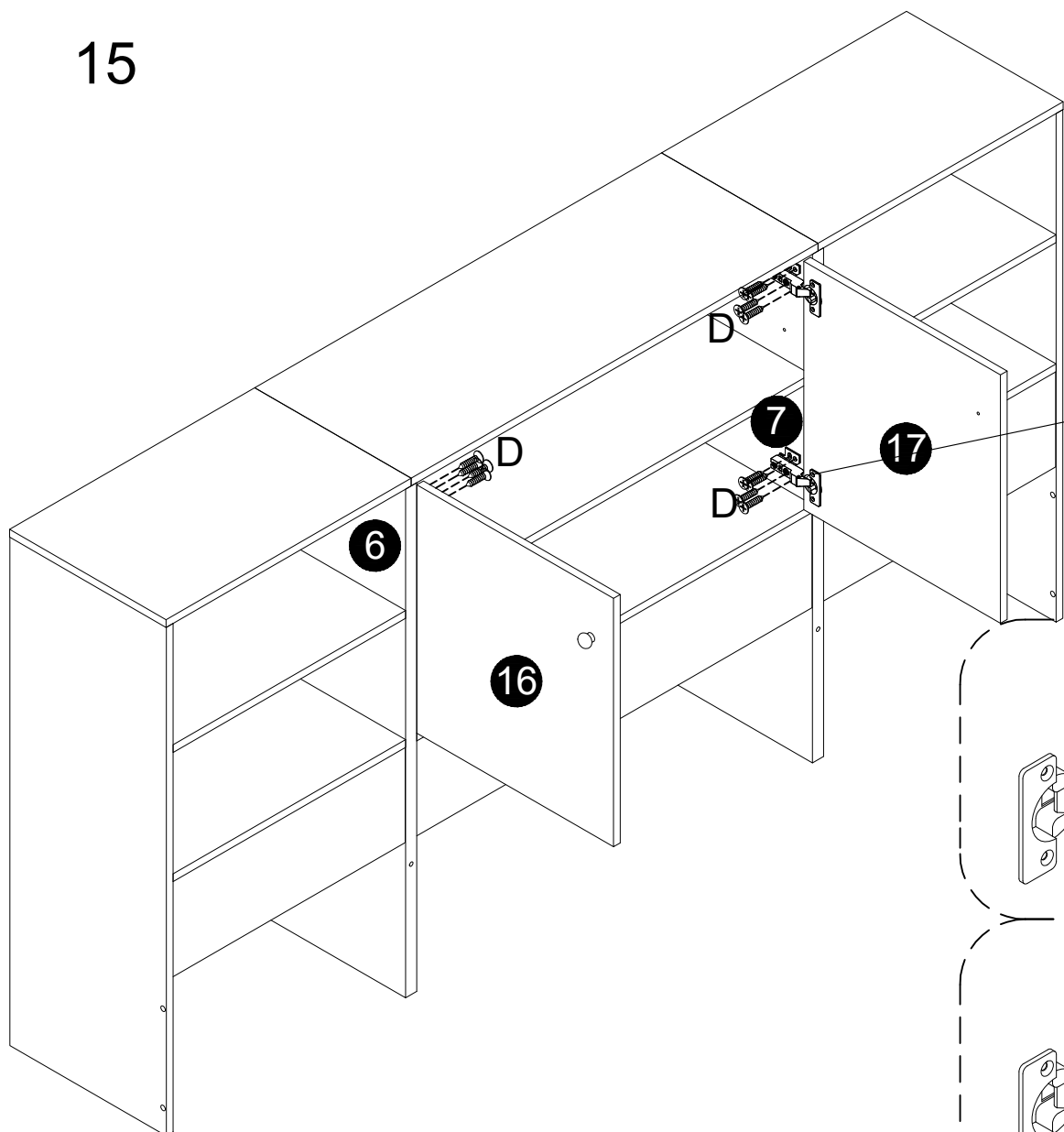

D		16PCS
---	--	-------

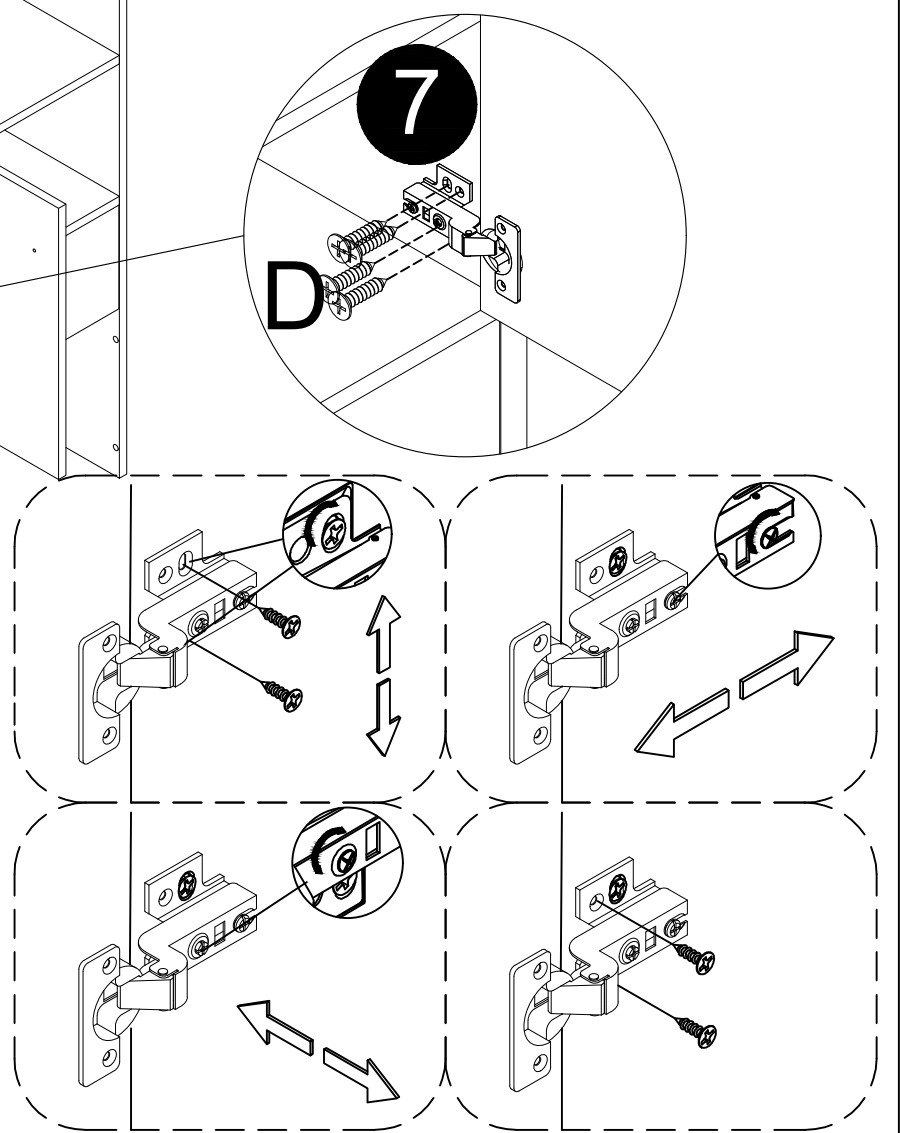

16

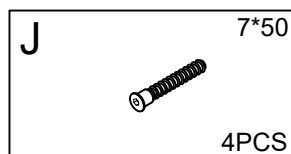
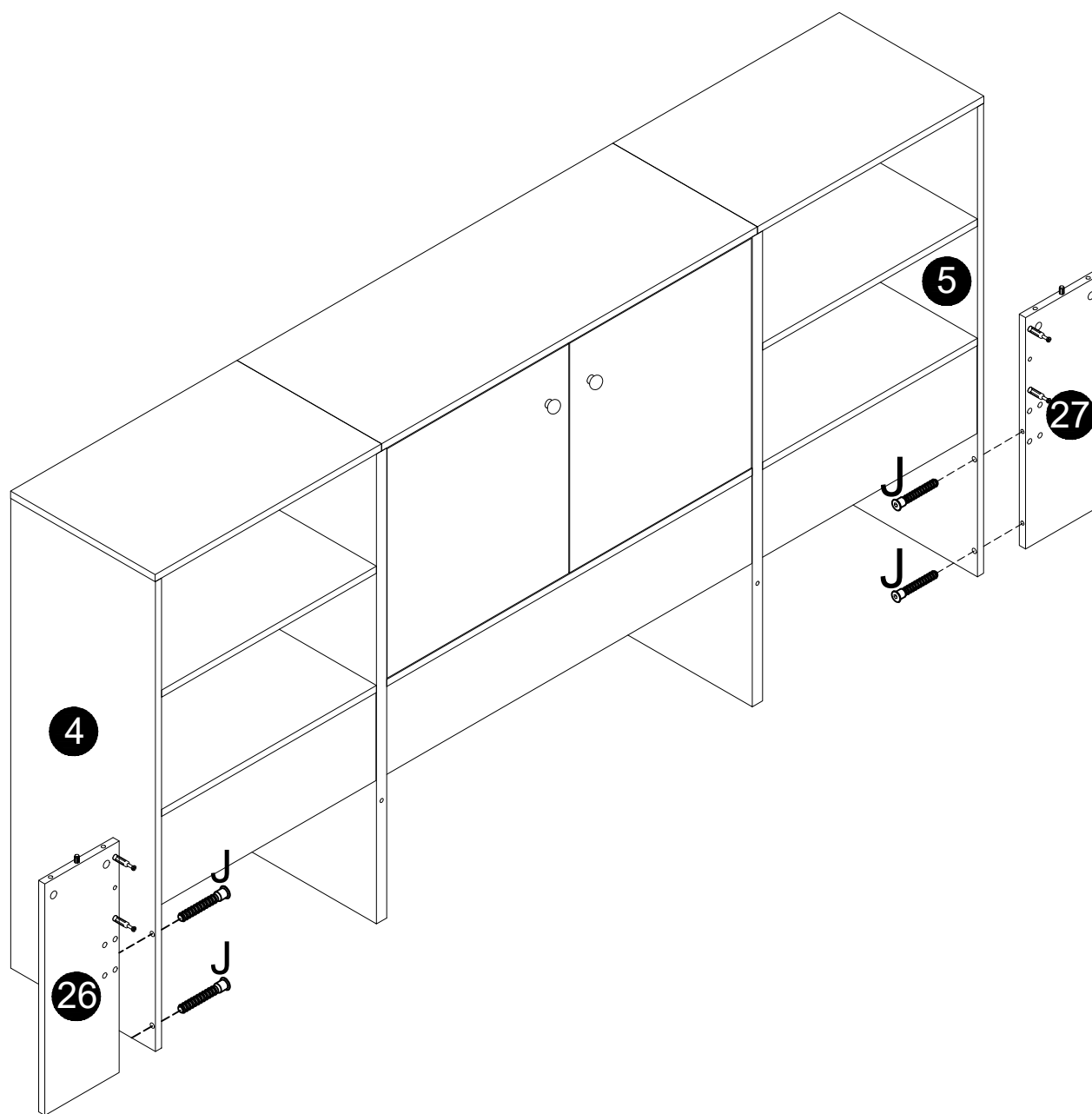

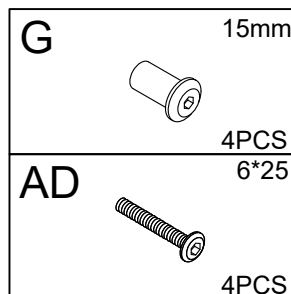
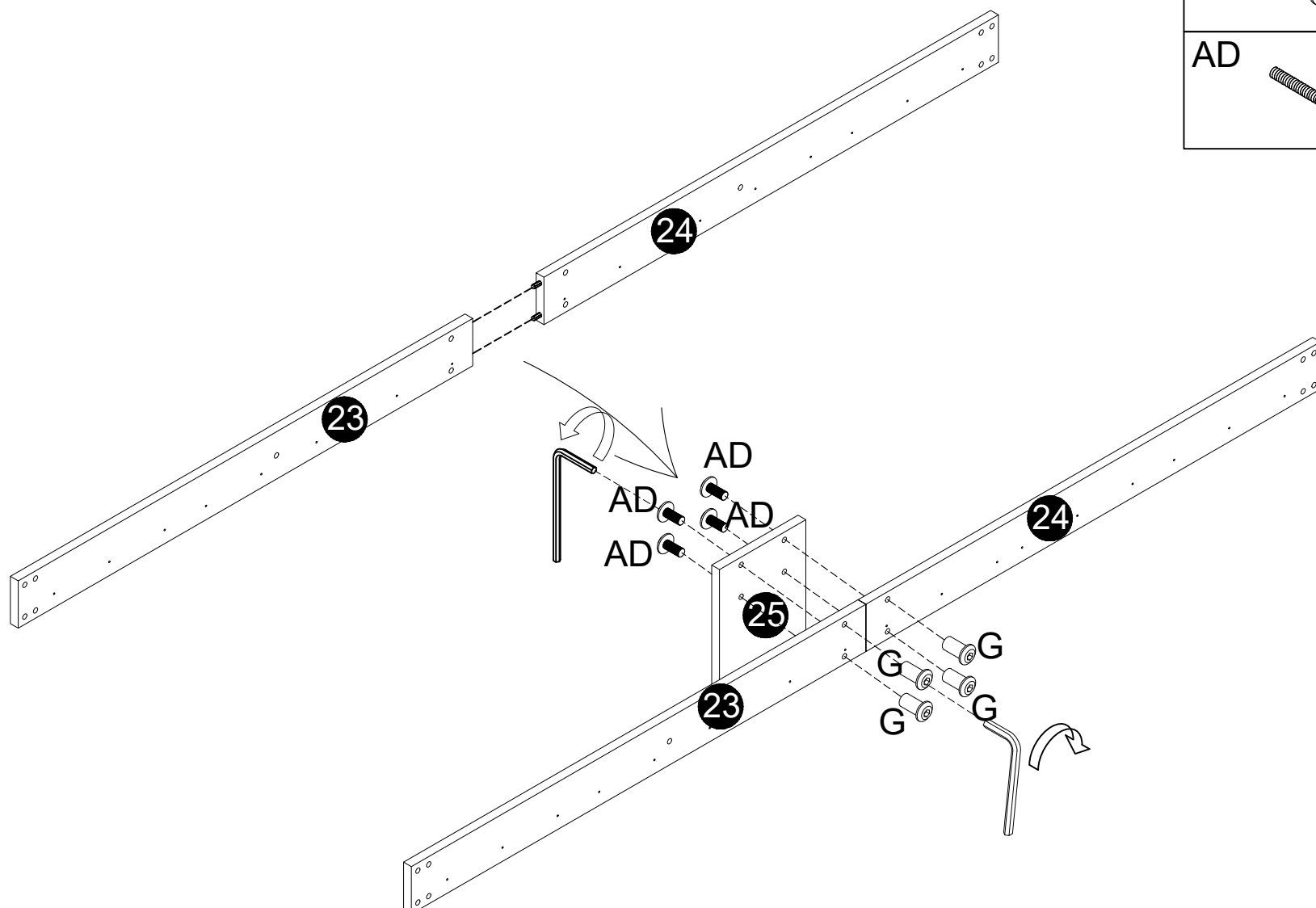

17



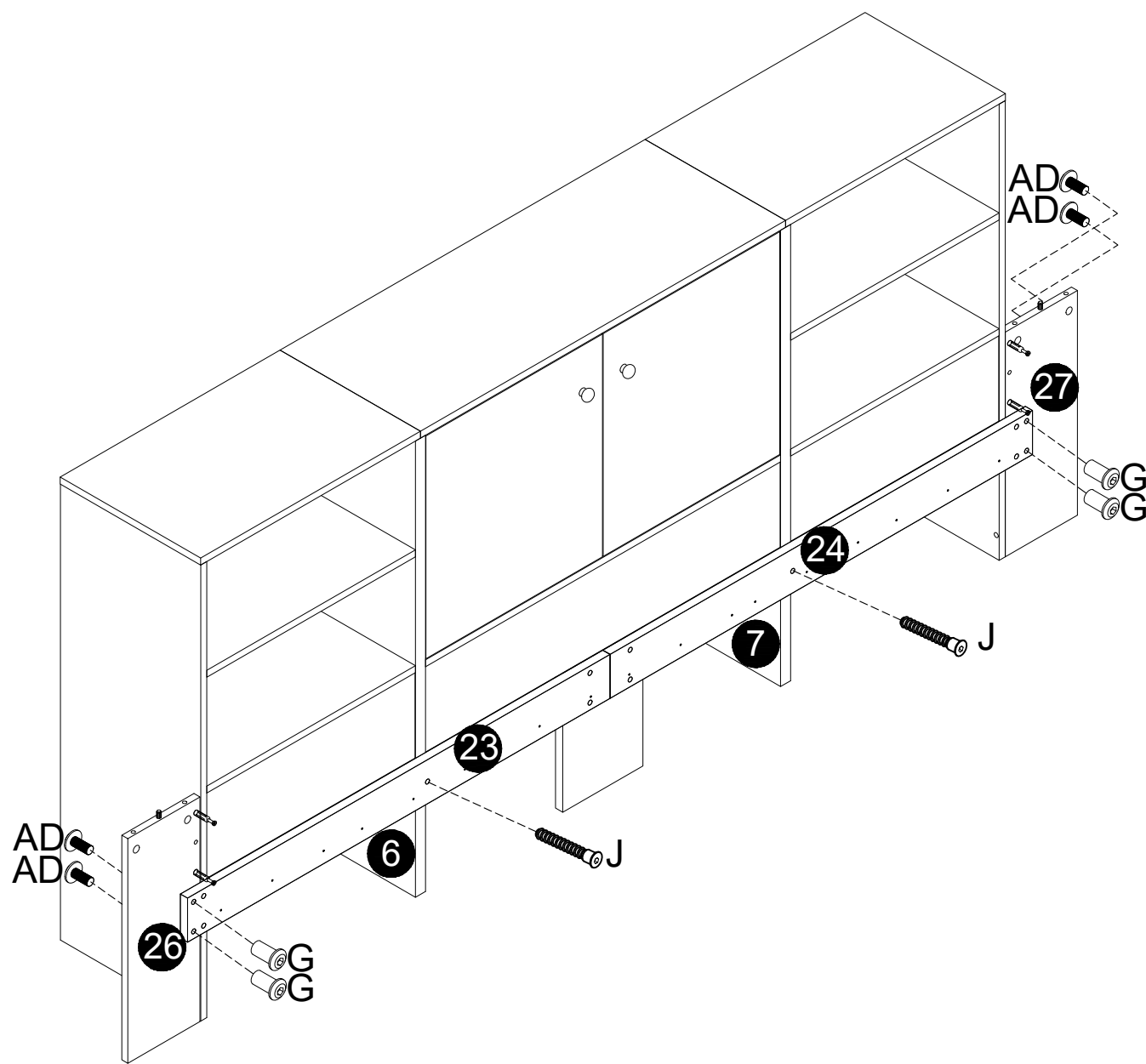

18

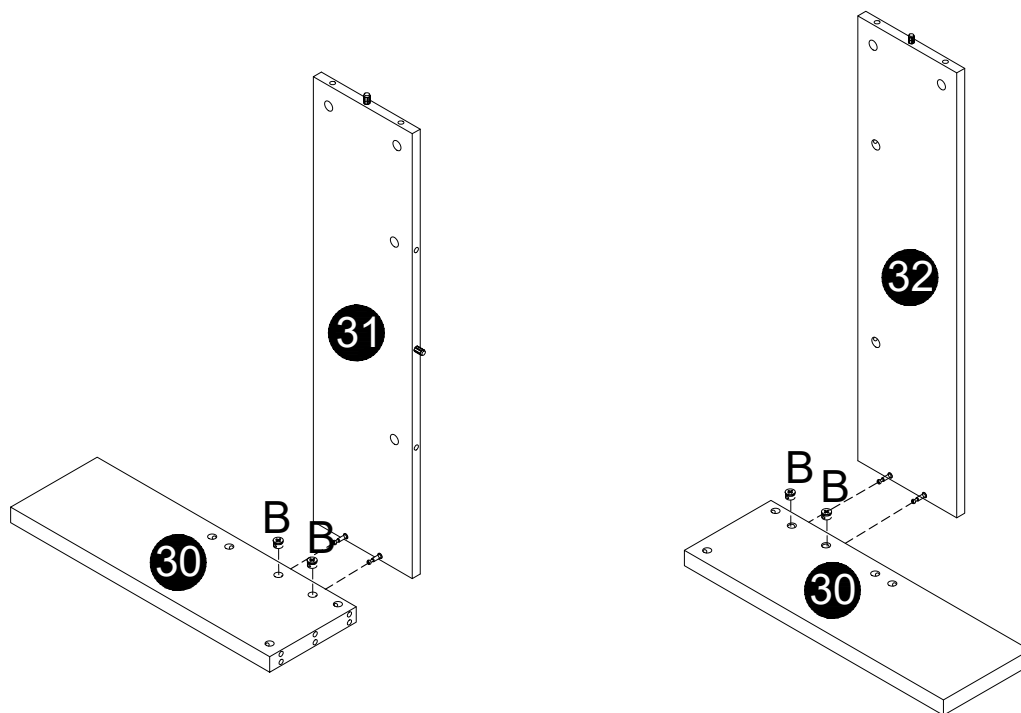
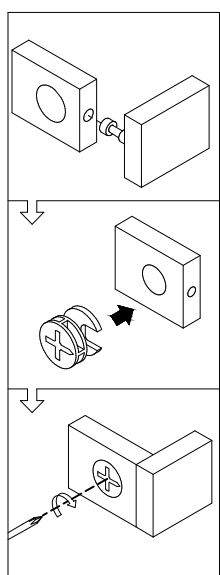

G	15mm
	4PCS
AD	6*25
	4PCS
J	7*50
	2PCS

19



B	15*10
	4PCS

20

B 15*10
4PCS

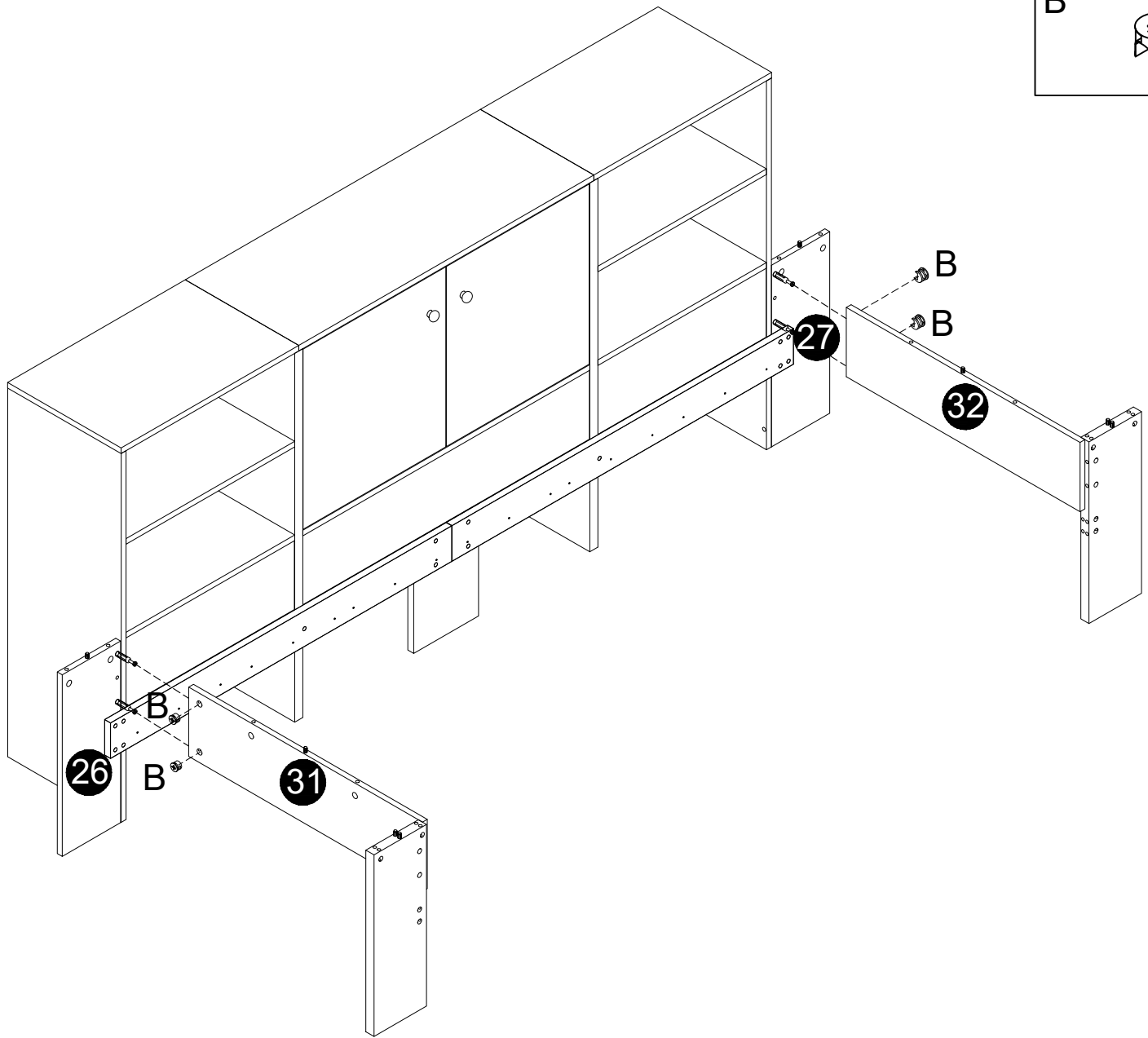
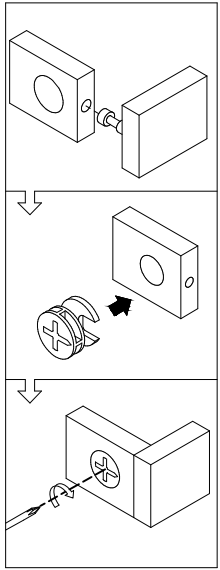

21

B 15*10
2PCS

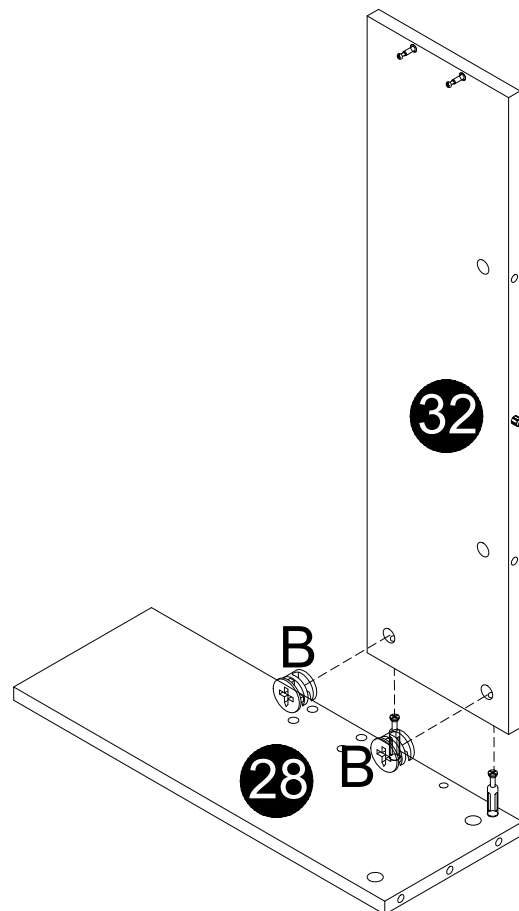
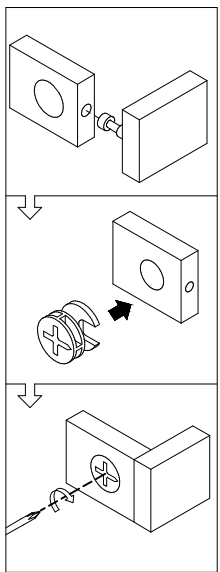

22

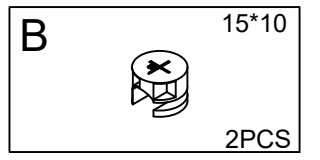
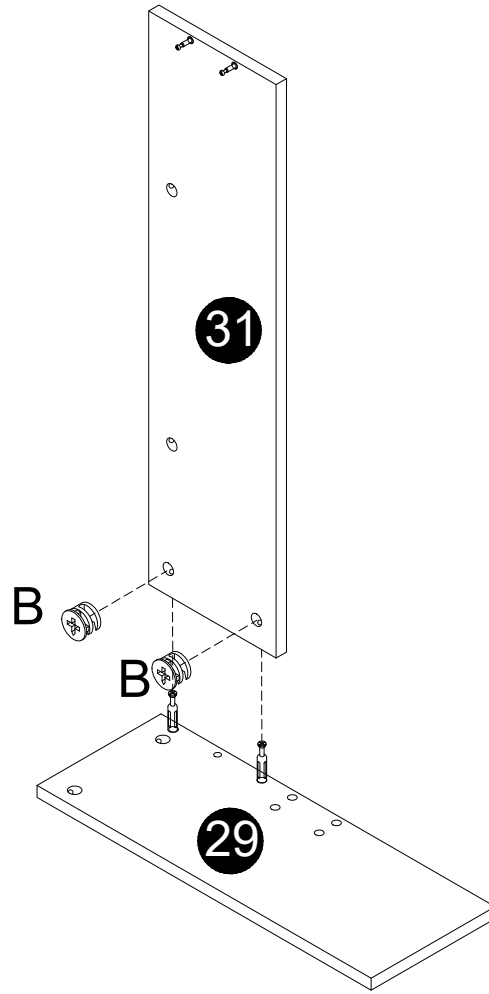
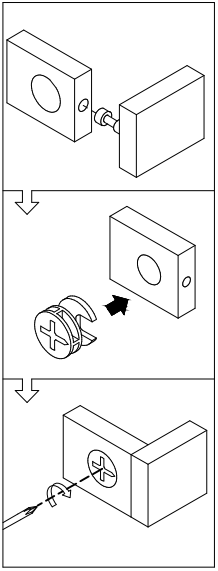

23

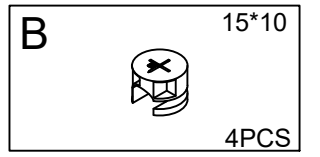
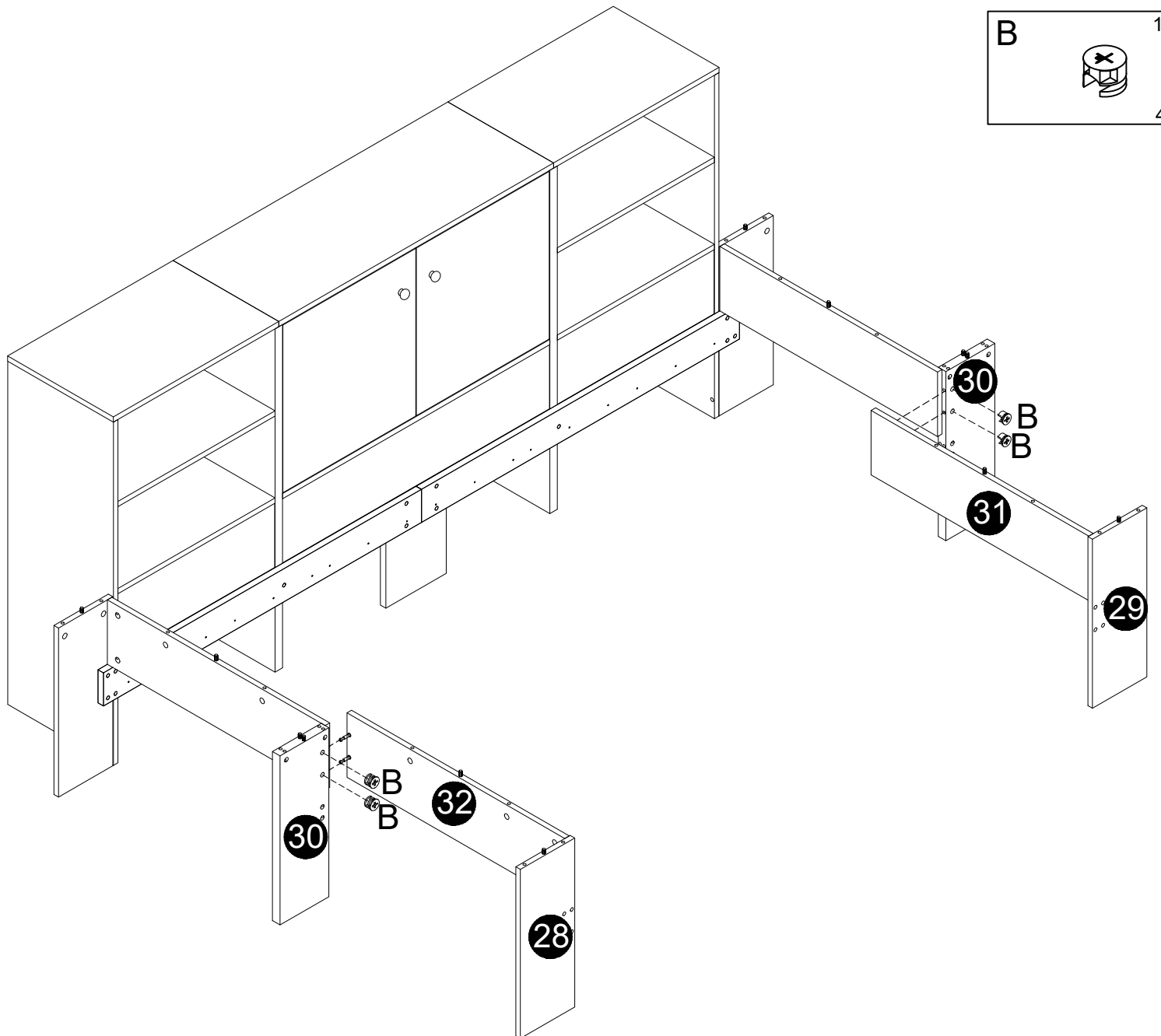
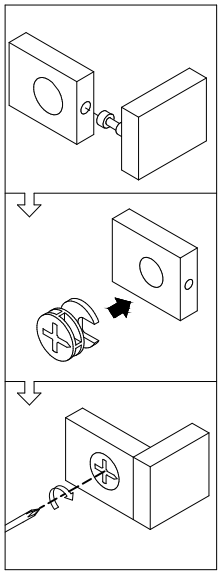

24

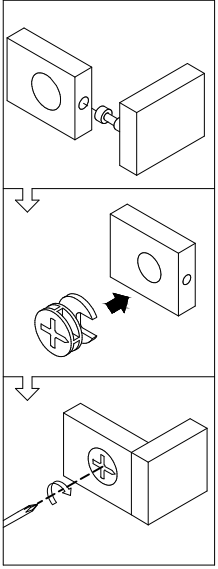

B 15*10
24PCS

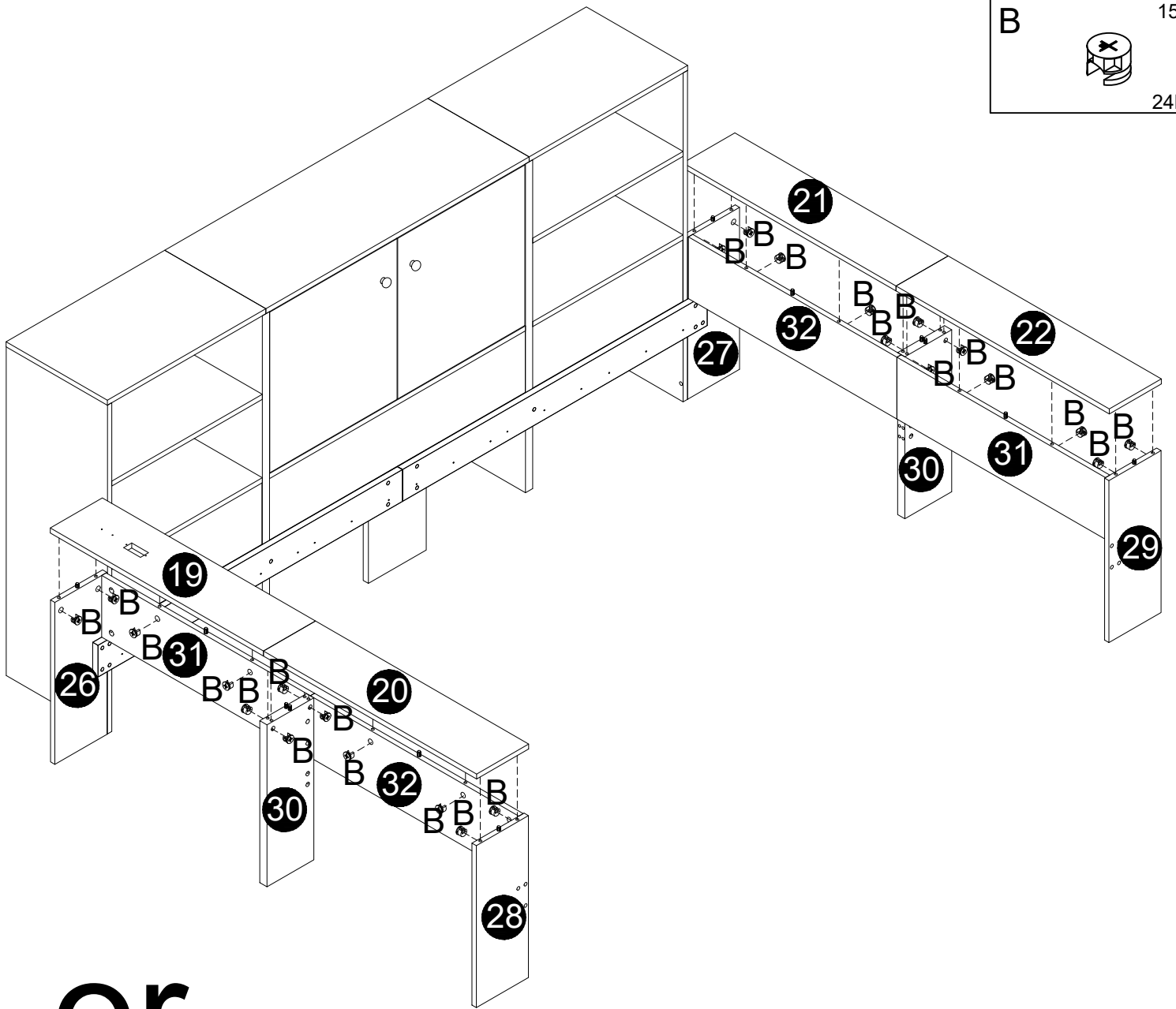

or

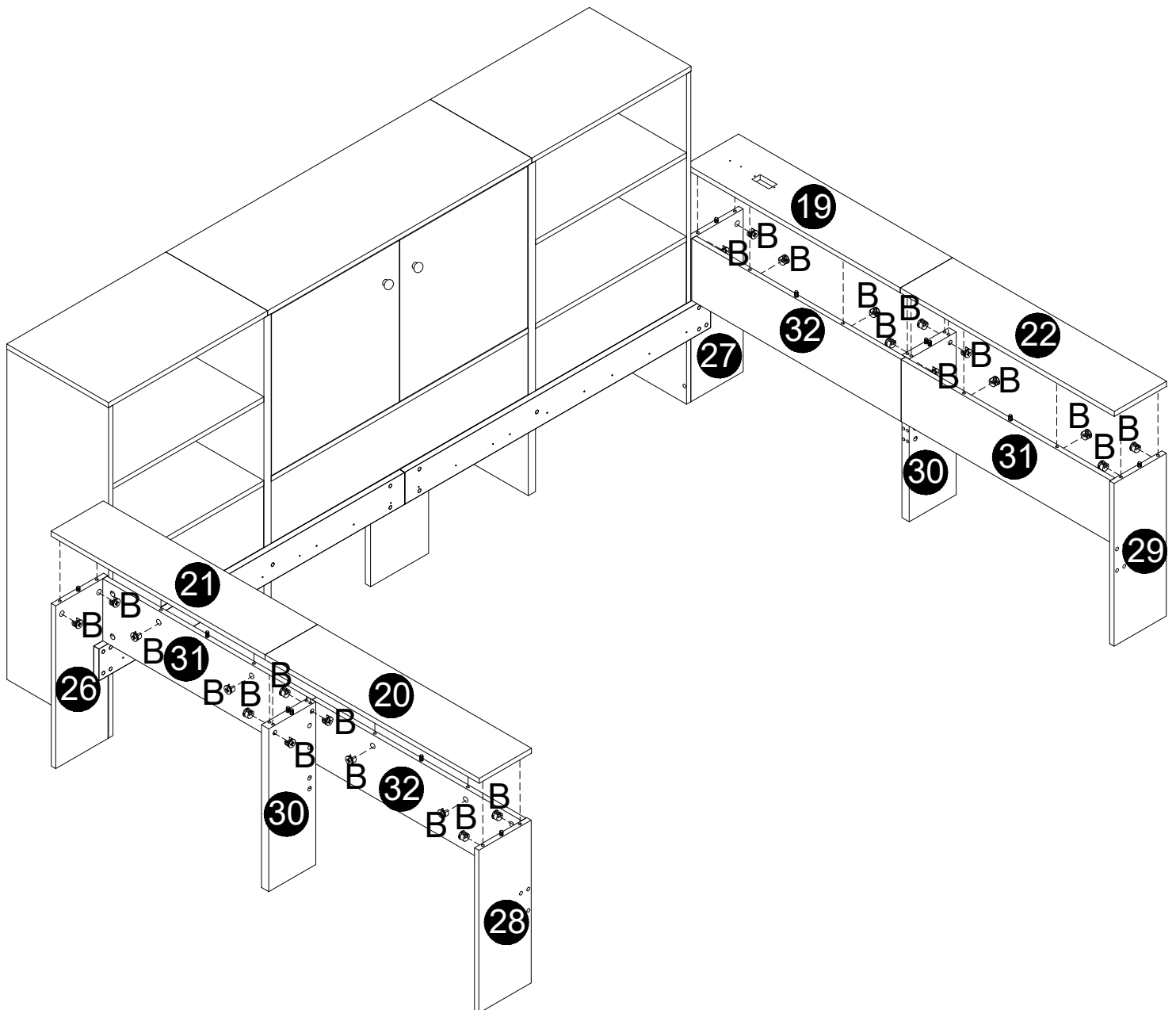

25

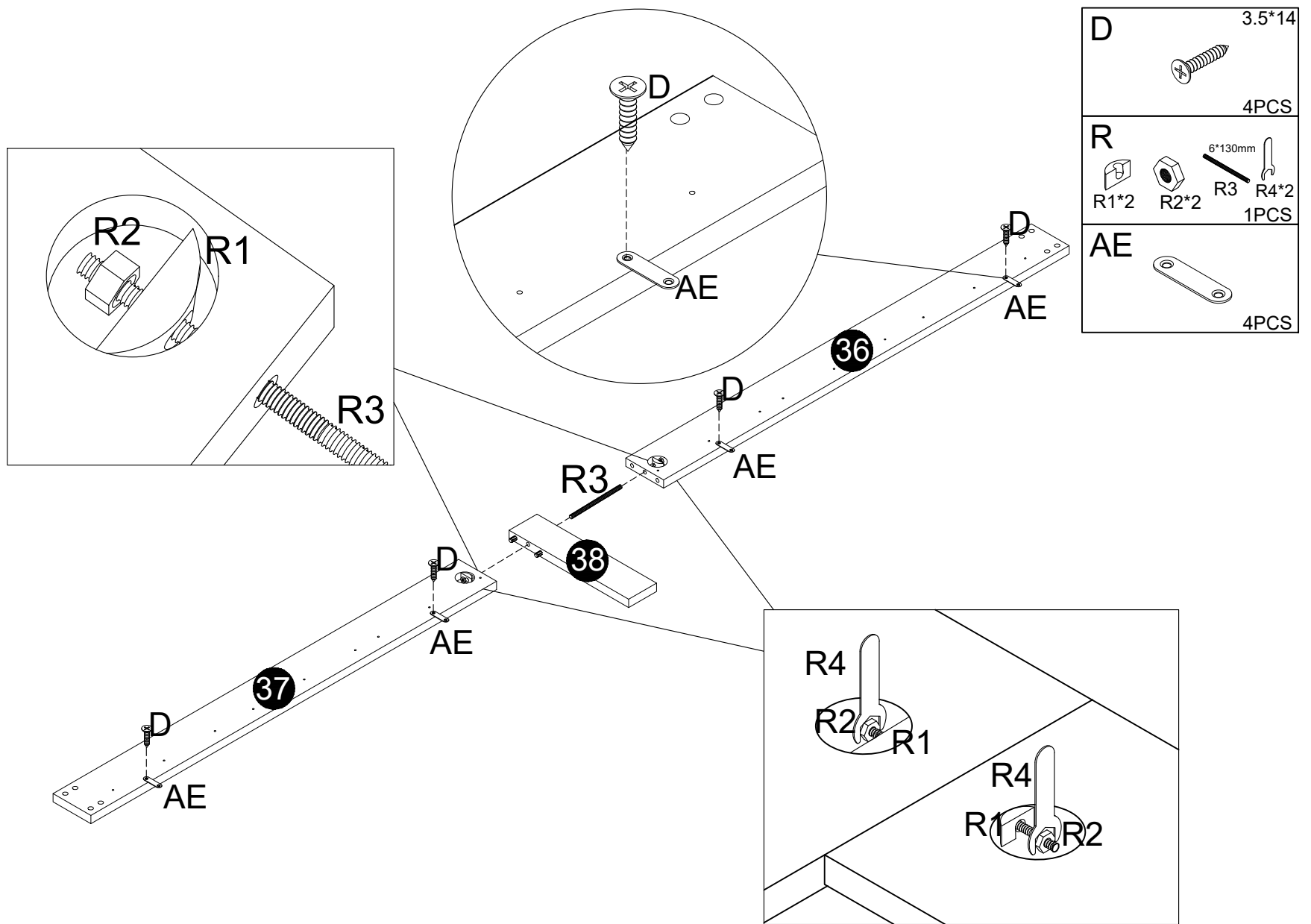

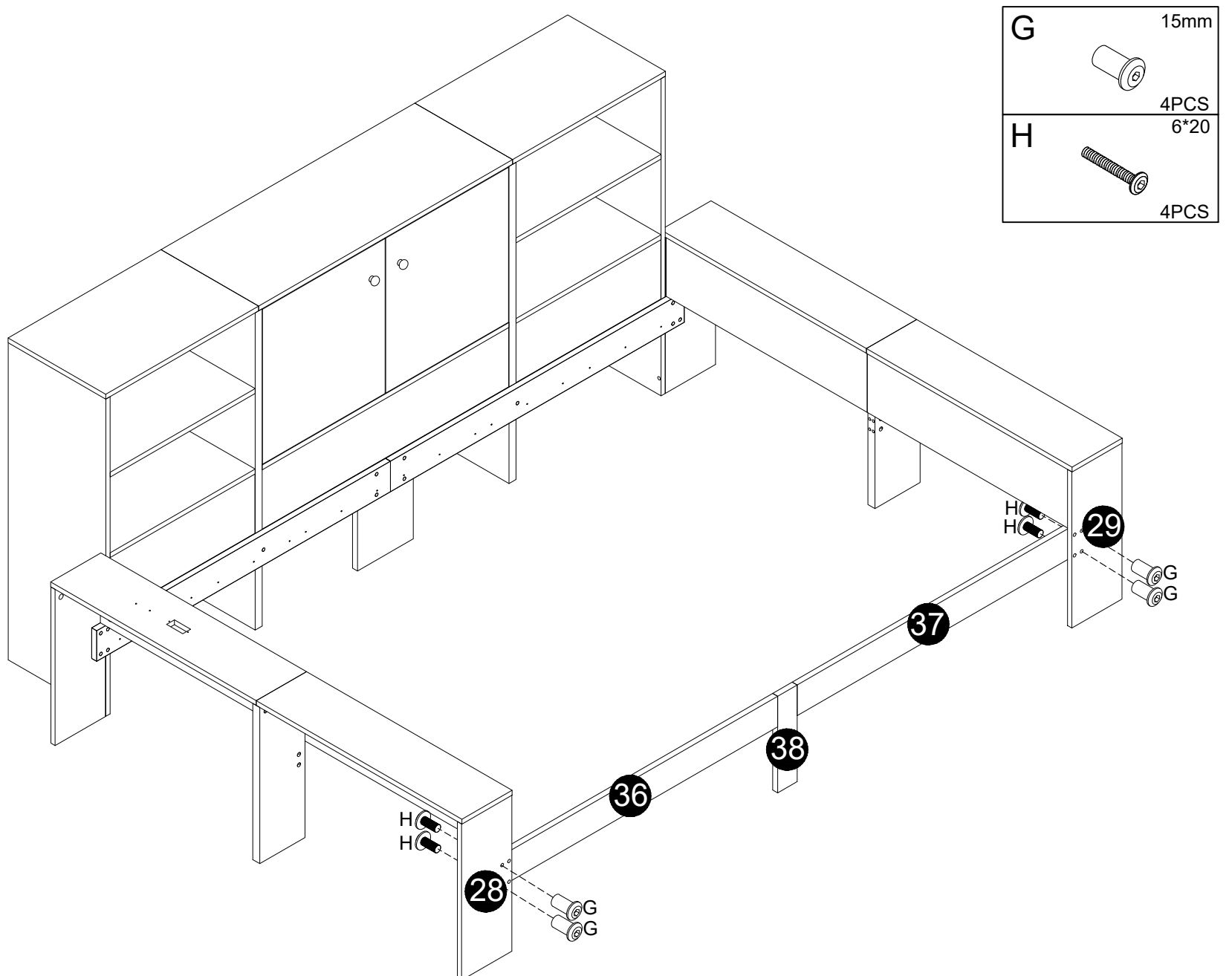

26



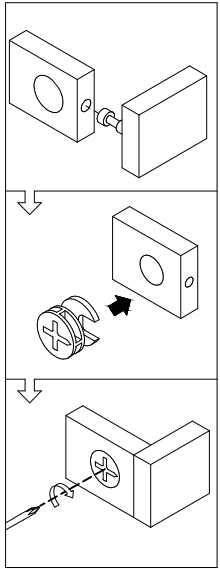

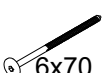
27

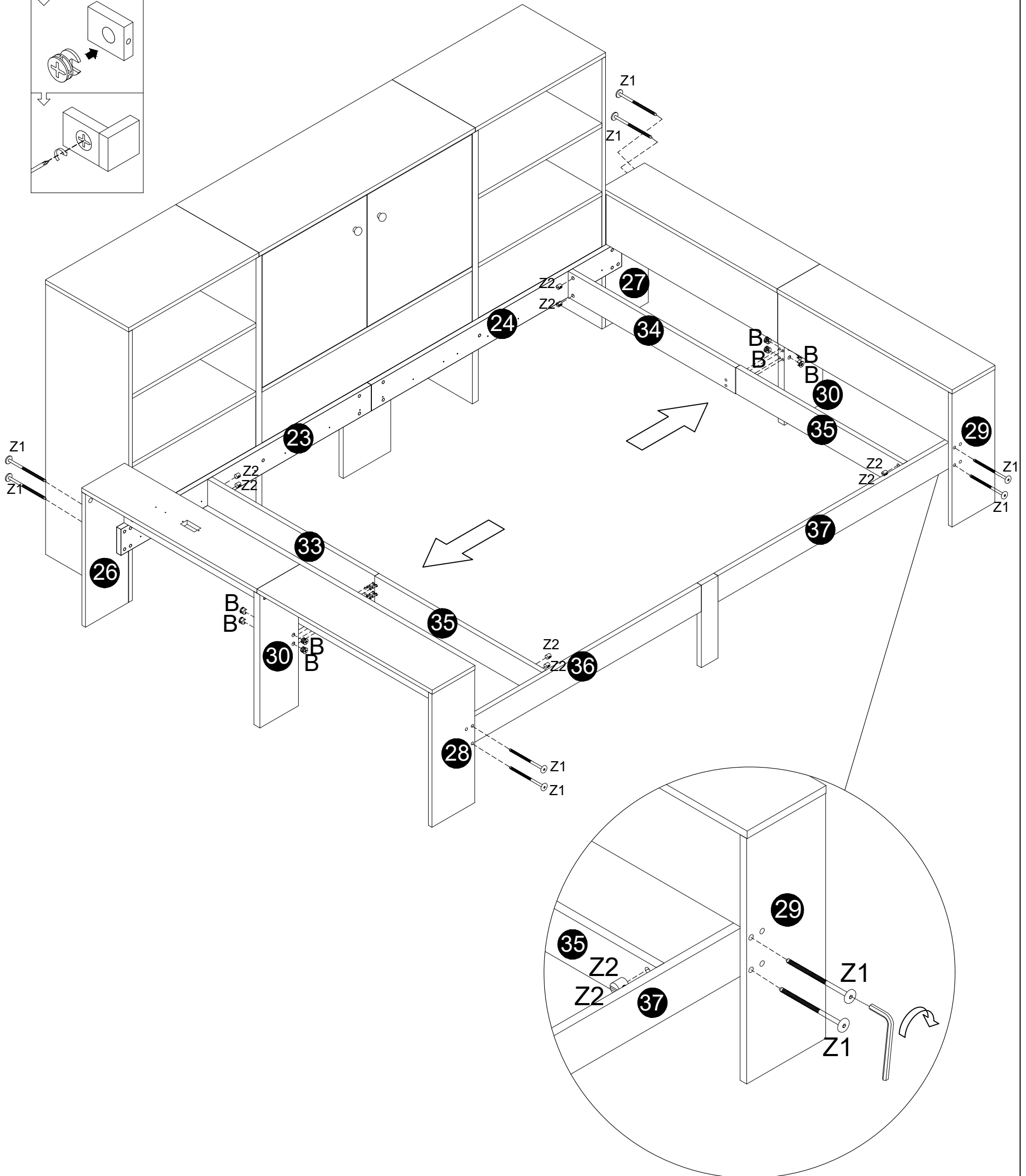

B		15*10
		8PCS
Z		6x70 Z1
		12mm Z2
		8PCS



28

G	15mm
	6PCS
H	6*20
	6PCS

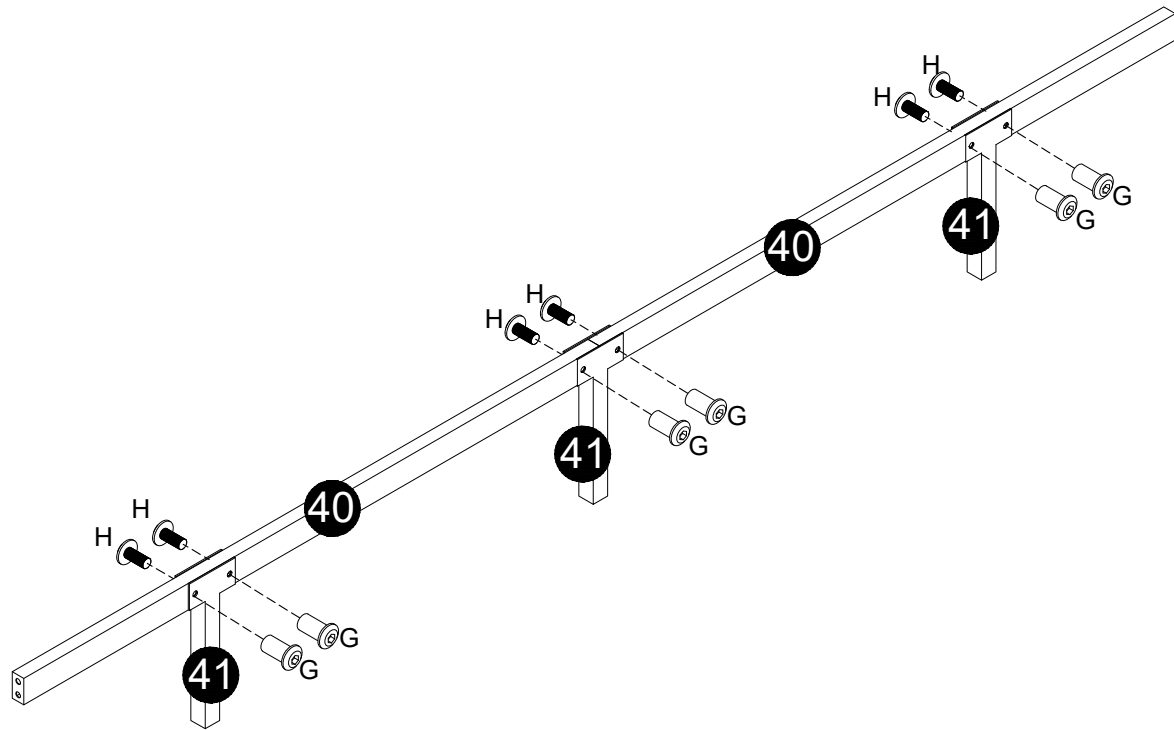

29

AF	6*40
	4PCS

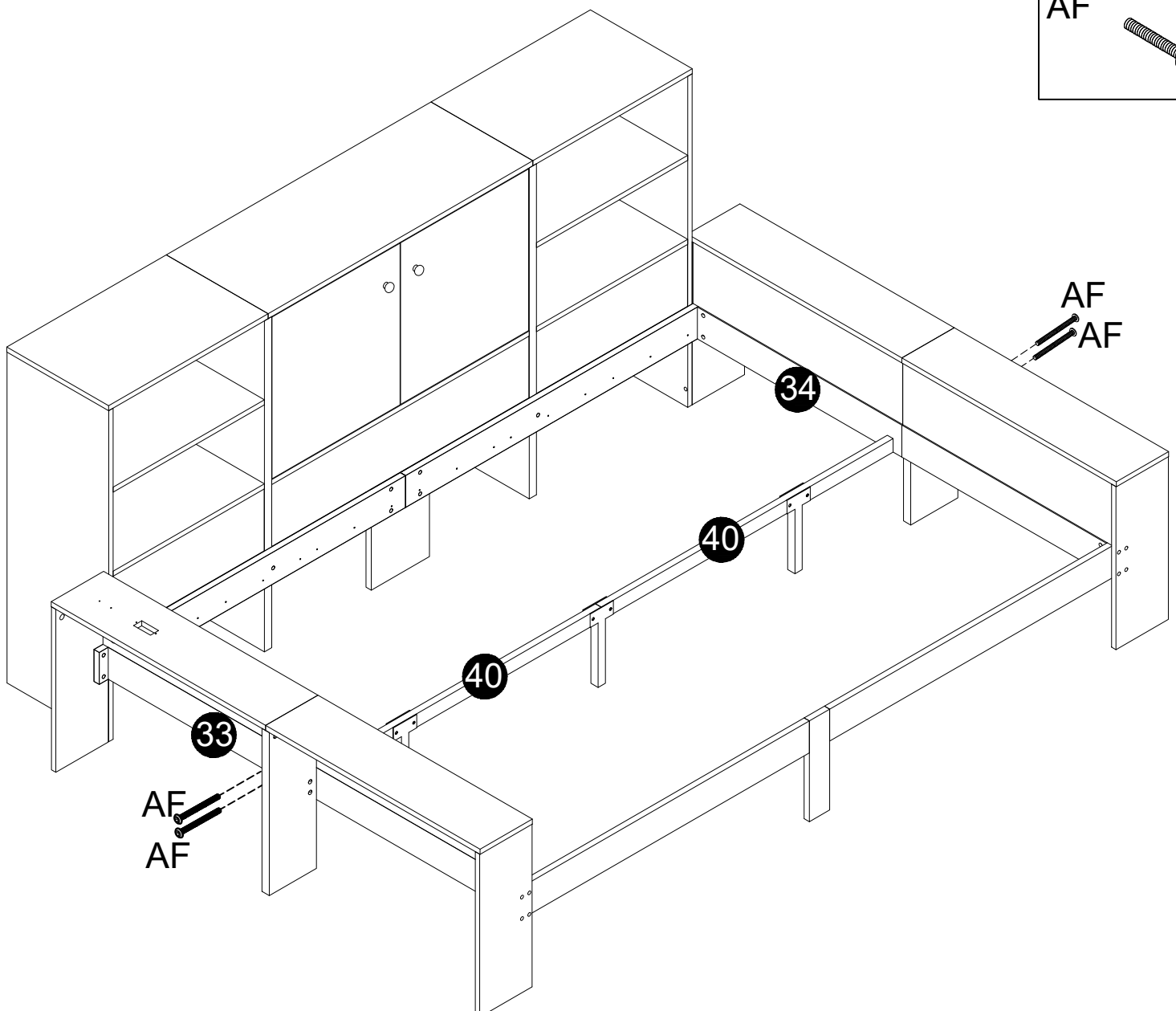

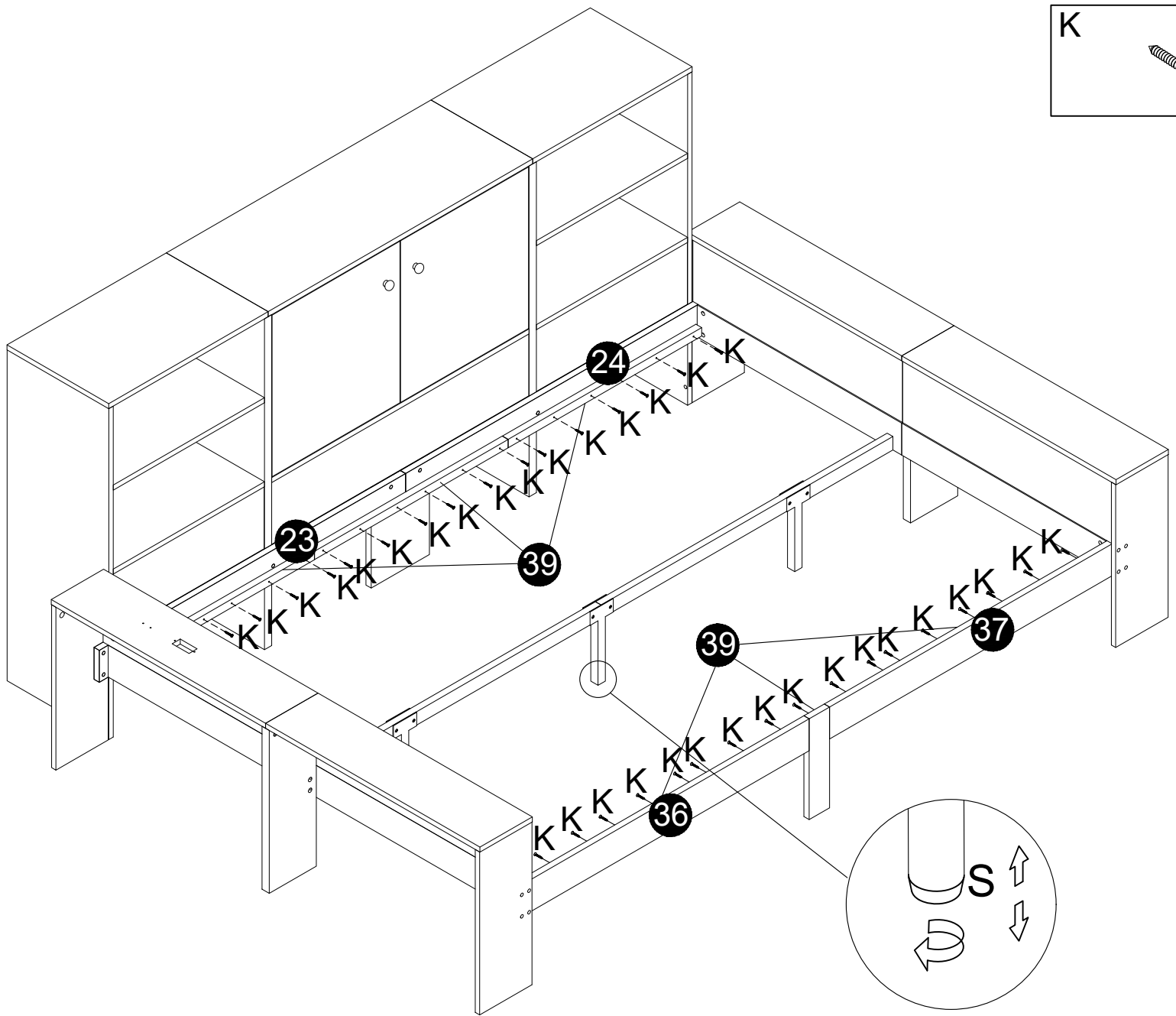

30

K	4*30
	
	36PCS

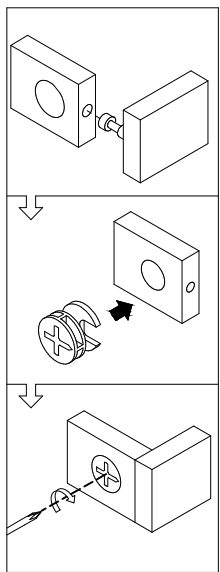

31



B	15*10
	
	4PCS
K	4*30
	
	8PCS

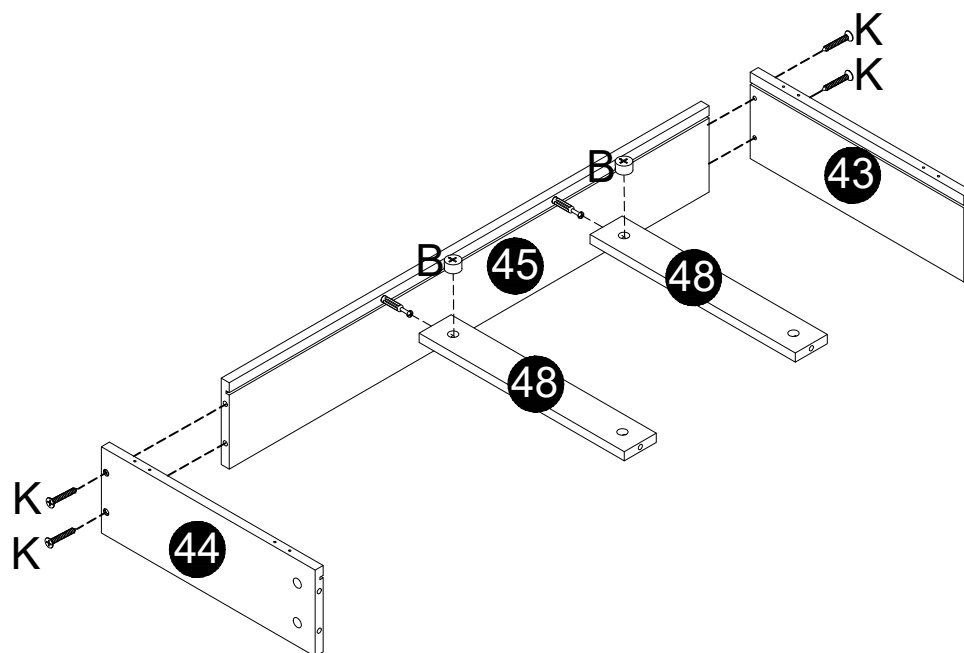

X2

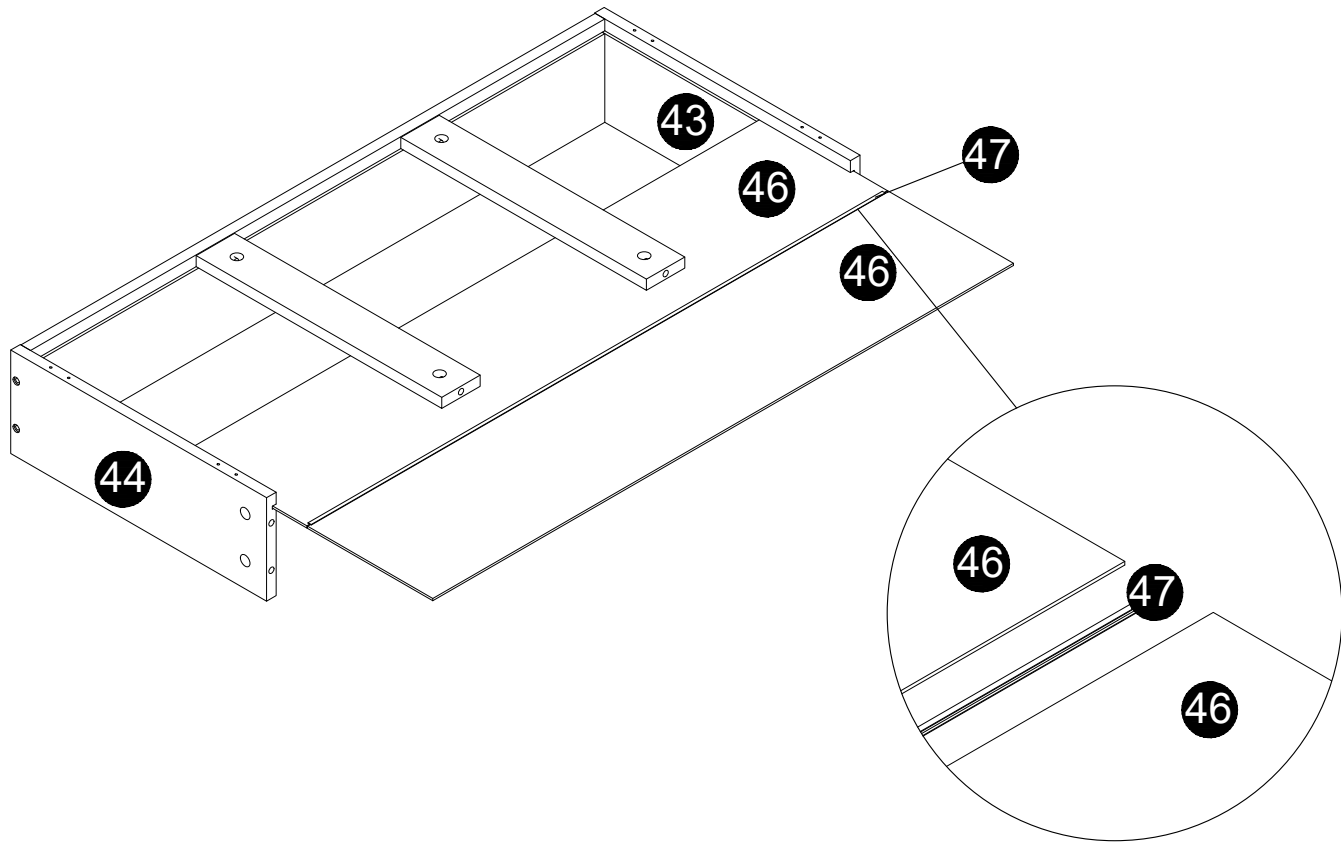

32

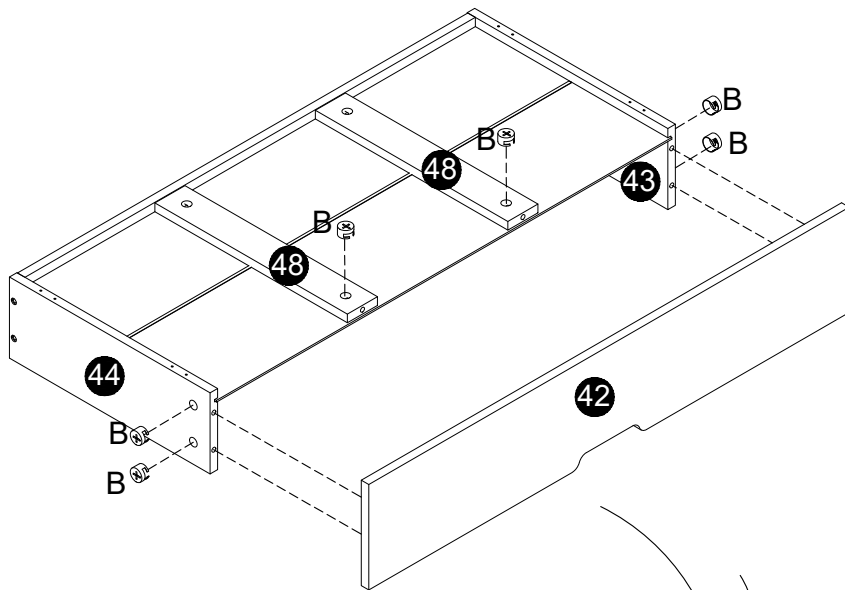
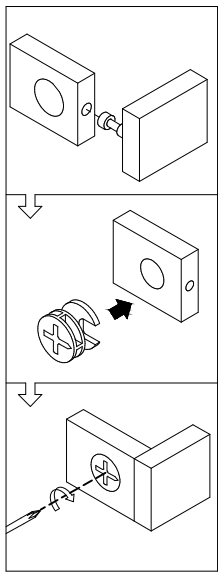

X2

33



B		15*10
		12PCS
D		3.5*14
		16PCS
AB		
		8PCS

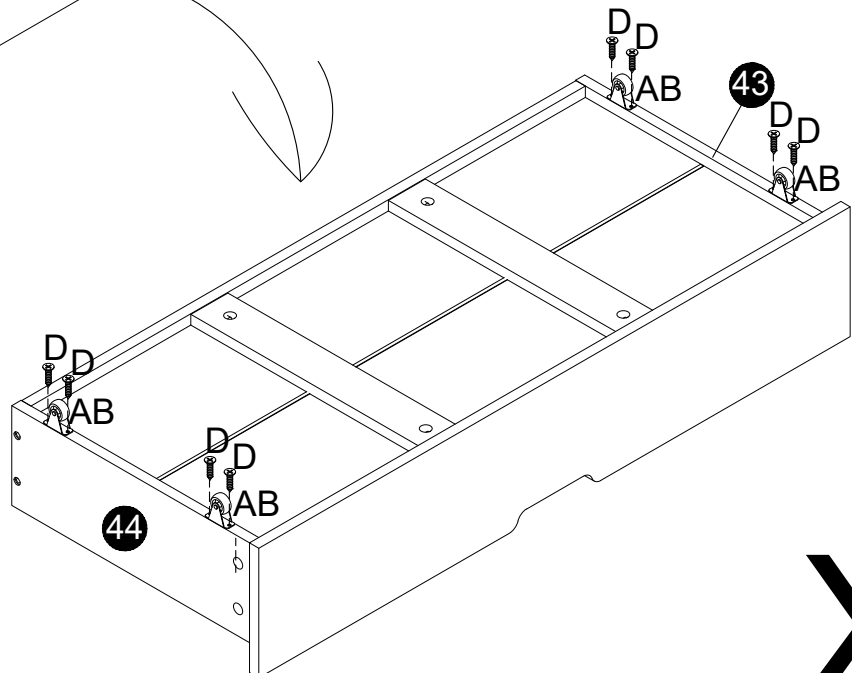

X2

34

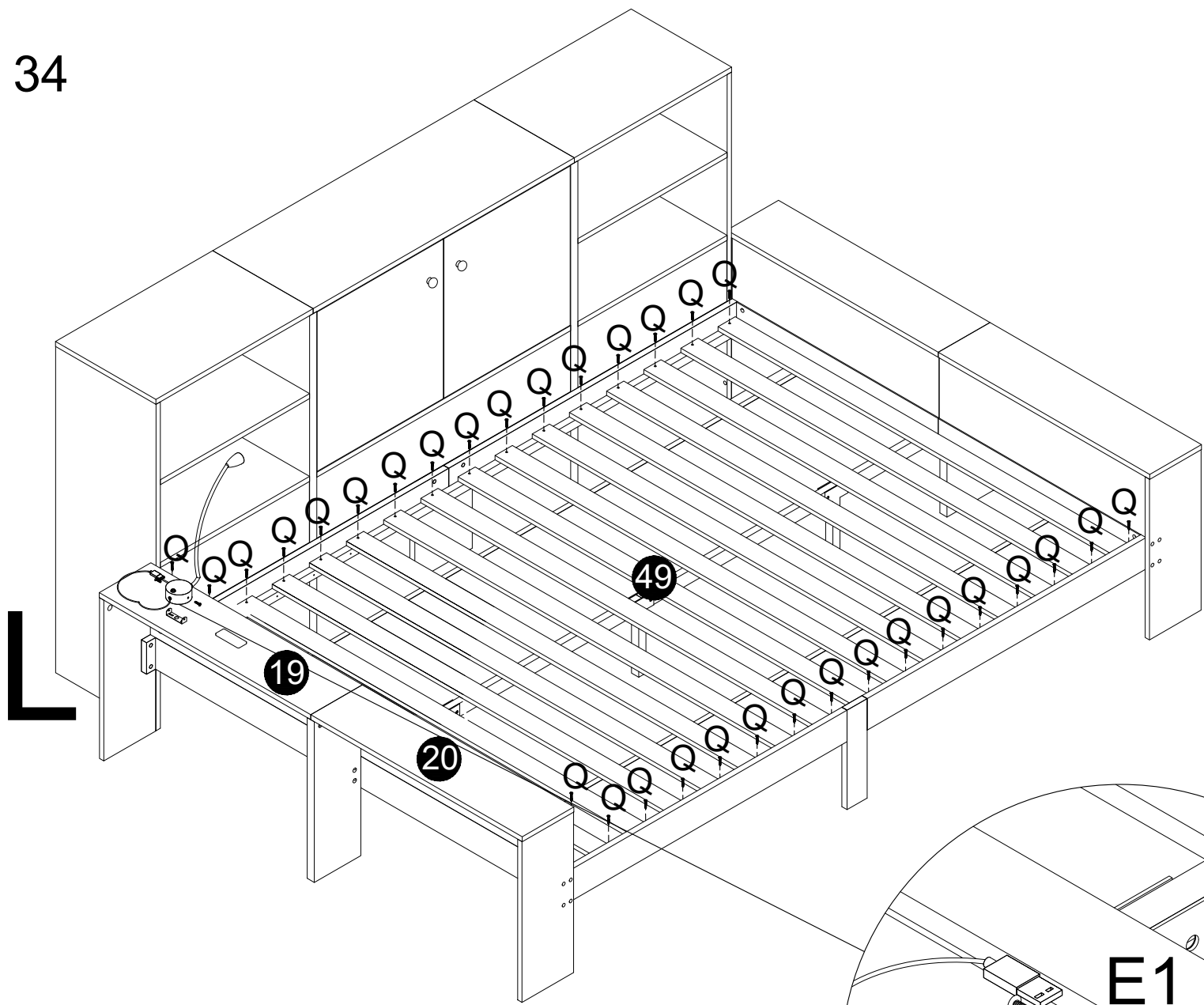

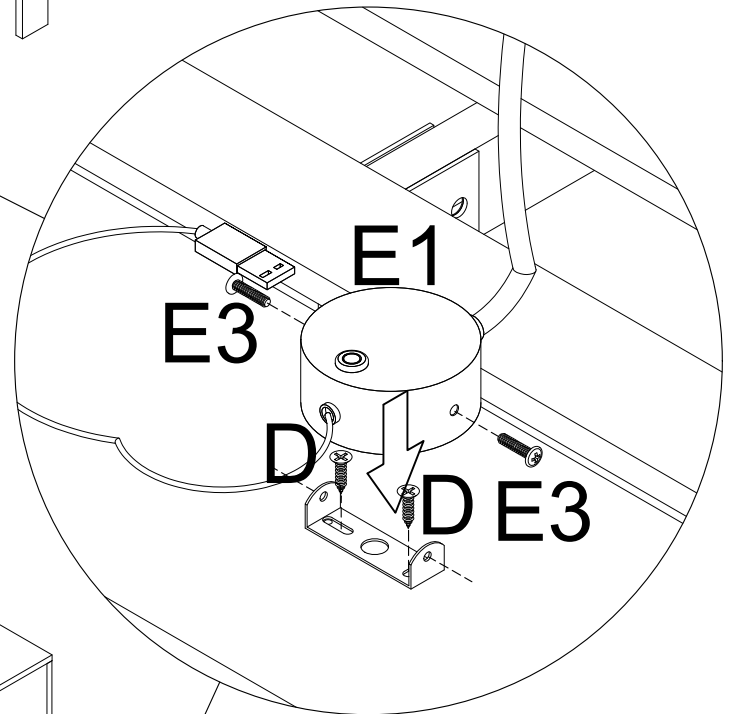

Q		3*30
		32PCS
E		
E1		E3
E2		1PCS
D		3.5*14
		2PCS

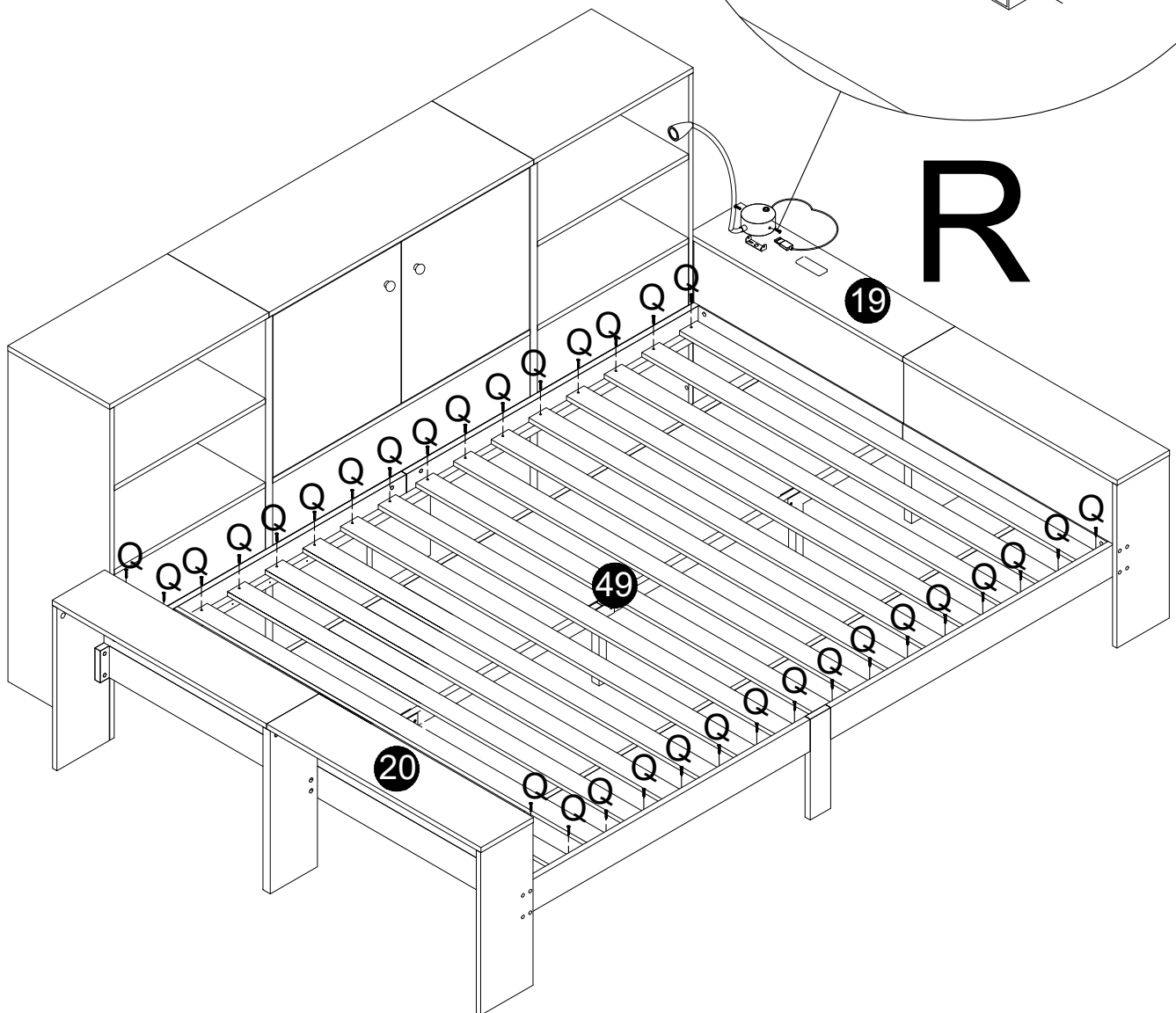

R

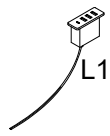

35

L		
	L1	L2
		1PCS
D		3.5*14
		2PCS

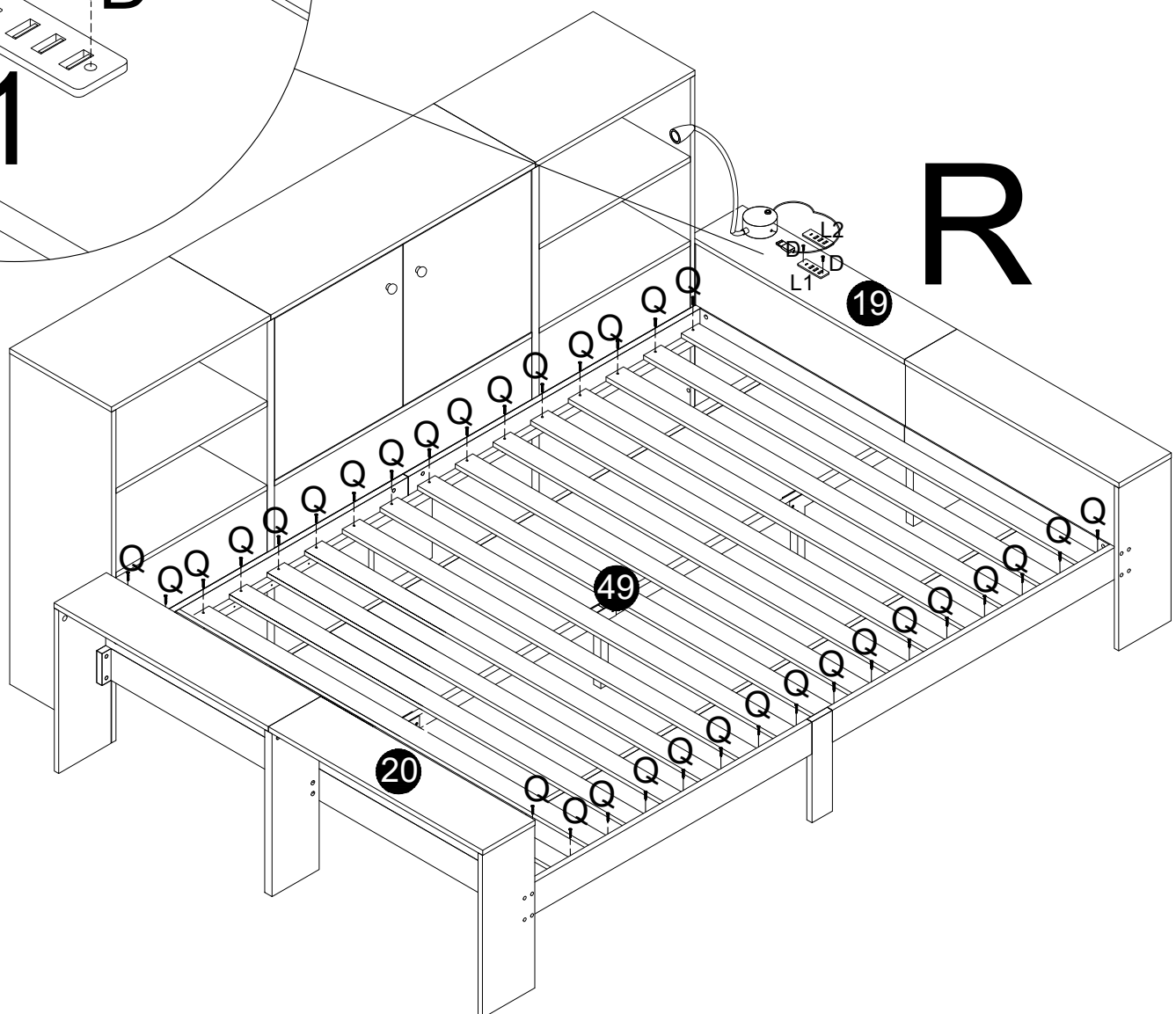
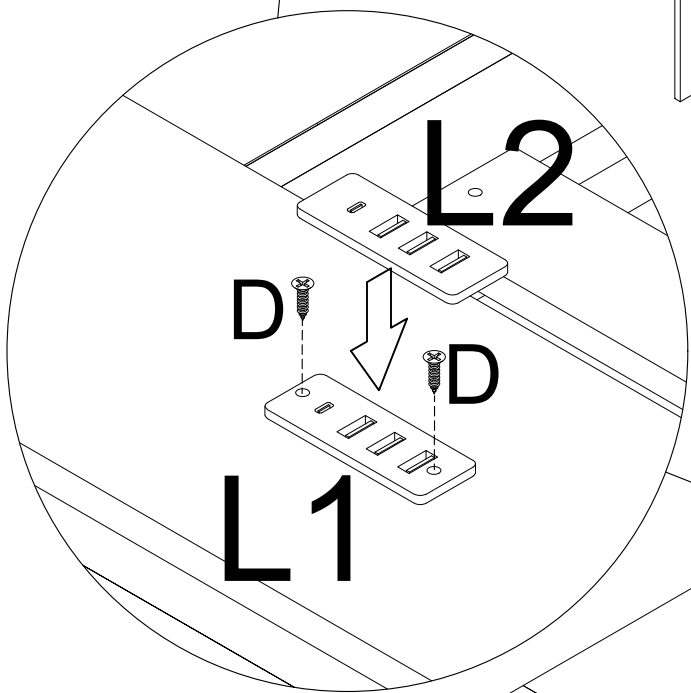
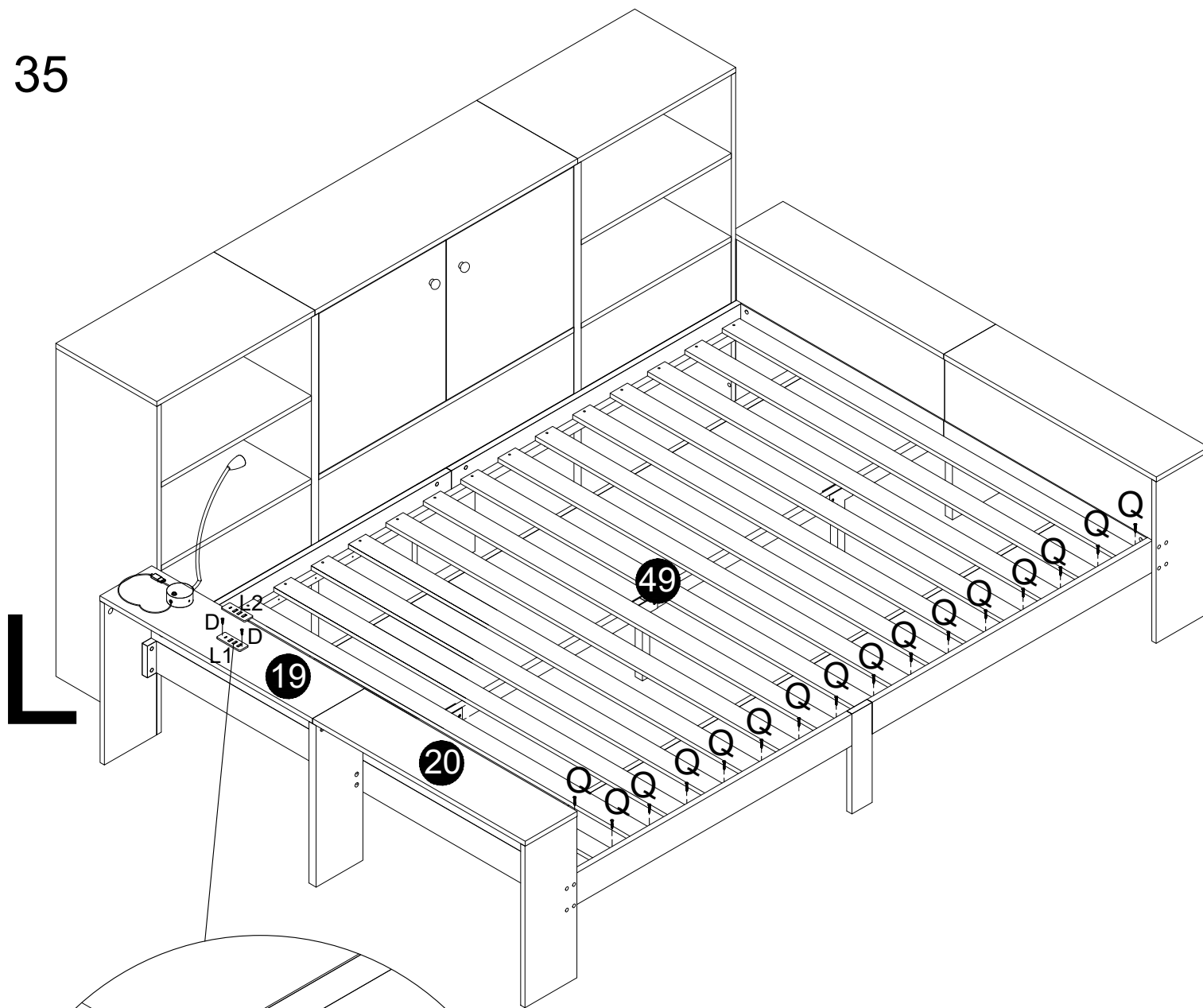

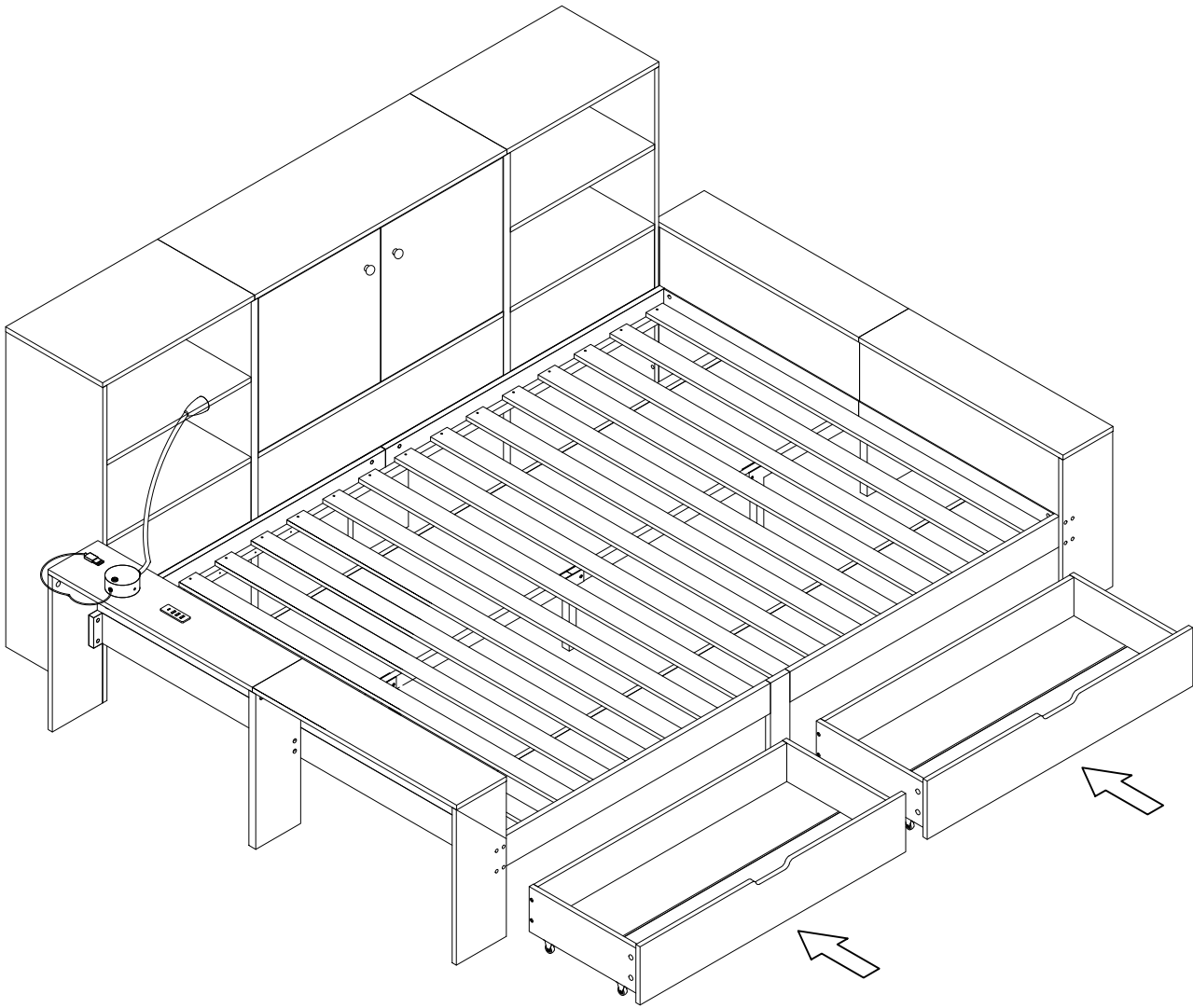

36



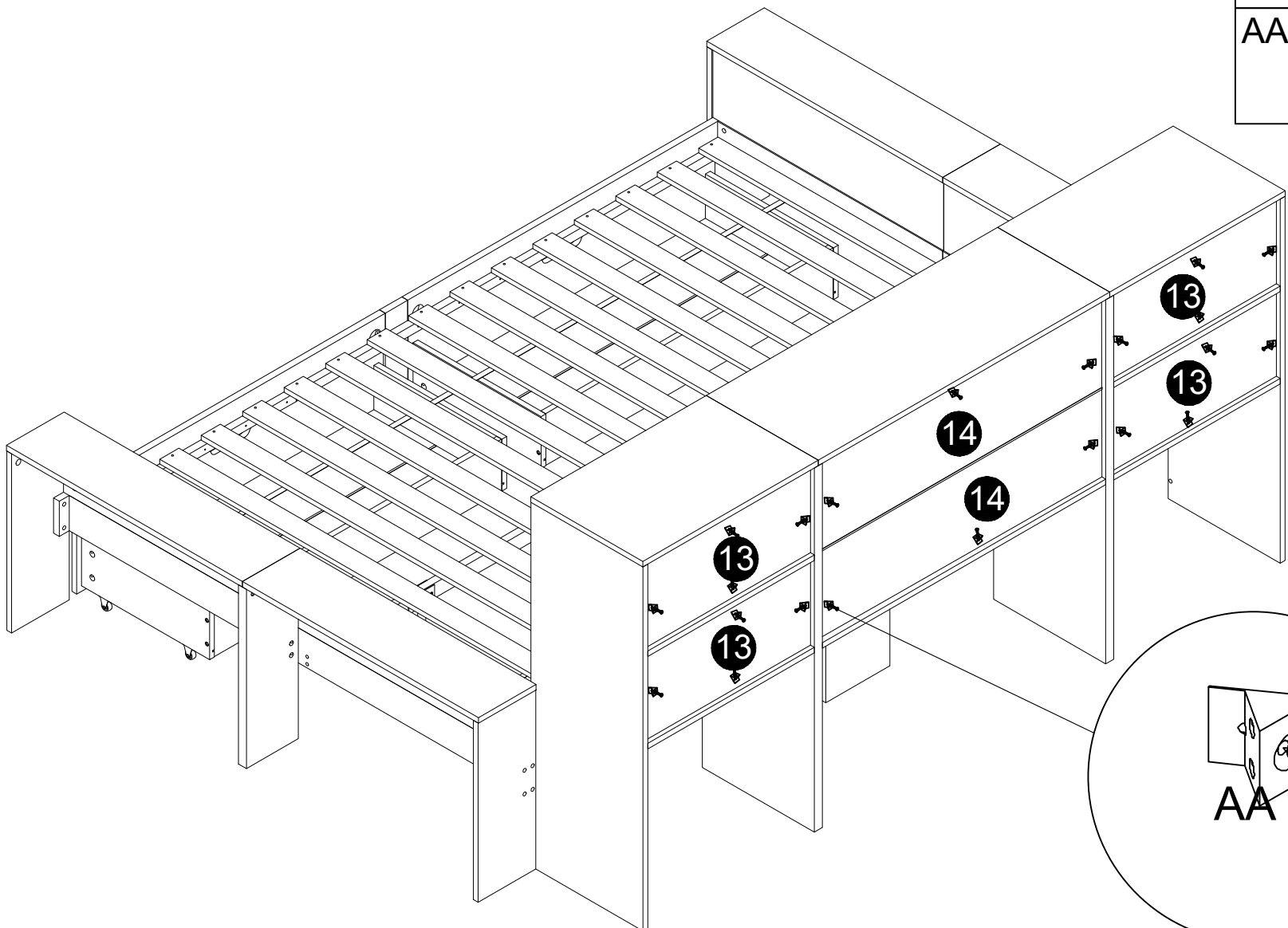

37

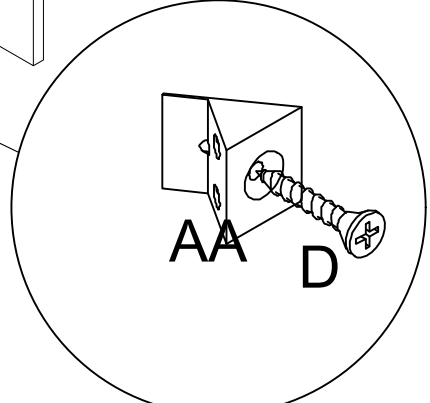

D	3.5*14
	22PCS
AA	
	22PCS

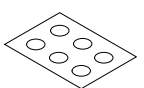
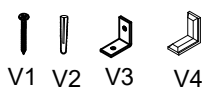

D	3.5*14
	14PCS
M	
	40PCS
V	
	2PCS
F	
	6PCS

Wall
Wand
Parete
Mur
Pared

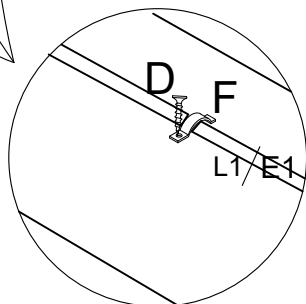
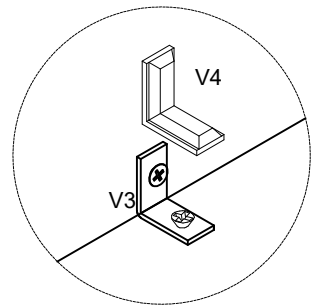
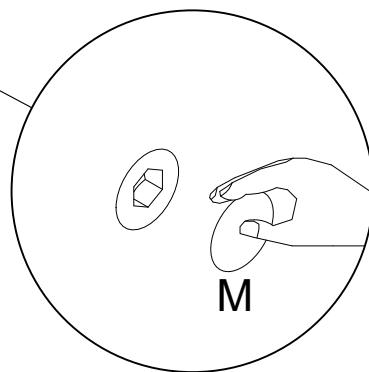
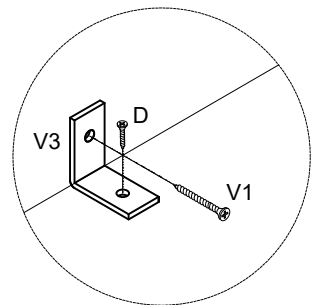
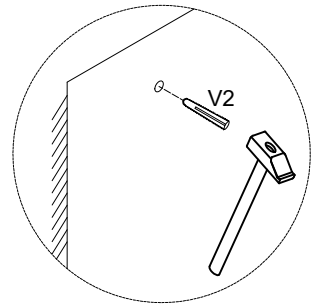
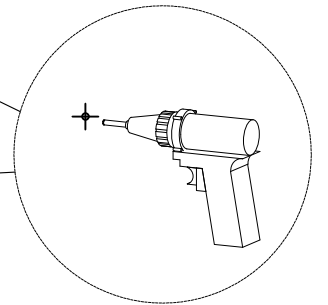
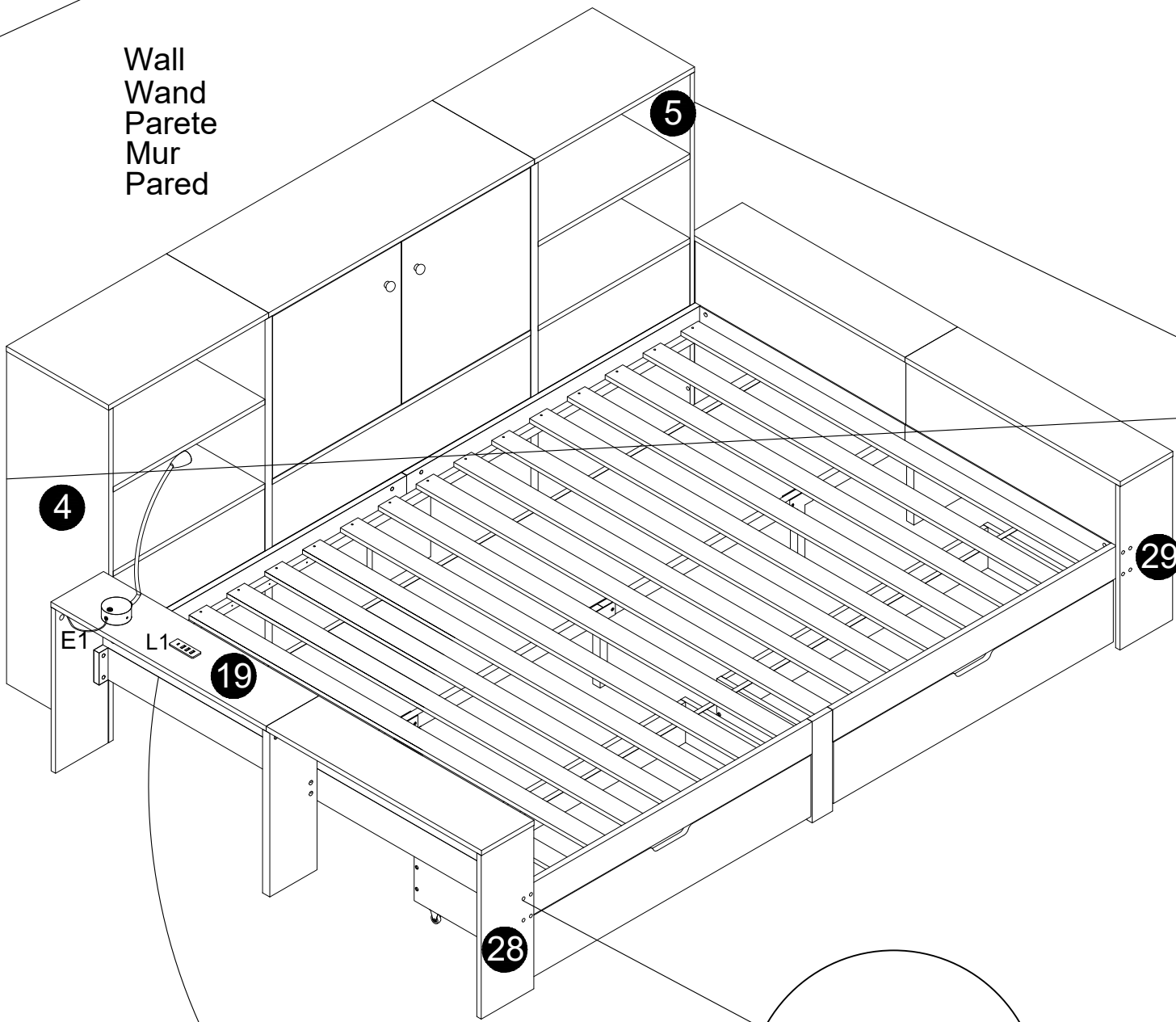



Certificate of Conformity

No.: CCI240300872EN-1CER

Reference Report No. : CCI240300872EN-1

Applicant : DONGGUAN BAIYOU ELECTRONIC CO LTD
Address : 2F A Building, Wufeng Industrial, Jintan Road,
Danwu Shijie Town, Dongguan, Guangdong

Sample Name : USB CHARGER
Model/Item No. : BY213-TD04-C

Test Standards : IEC 62321-2:2013 IEC 62321-6:2015
IEC 62321-3-1:2013 IEC 62321-7-1:2015
IEC 62321-4: 2013+A1:2017 IEC 62321-7-2:2017
IEC 62321-5: 2013 IEC 62321-8:2017

The submitted sample(s) stated as above has(have) been tested by us with the listed standards and found in conformity with the requirements stated in Directive 2011/65/EU of the European Parliament and of the Council with regard to the restriction of the use of certain hazardous substances in electrical and electronic equipment and its subsequent amendments as well as Commission Delegated Directive (EU) 2015/863. It is possible to use CE marking on the product to demonstrate the conformity with this Directive.

This certification is part of the full test report(s) and should be read in conjunction with it. The certificate is based on a single evaluation of one sample of above-mentioned products. It does not imply an assessment of the whole production. Other CE marking directives may be applied, they have not been considered during this RoHS conformity assessment.



Technical Director
Apr. 18, 2024



KeySense Testing & Certification International Co., Ltd.
 1-3F, Lab Building, No.29 District, Zhongkai Hi-Tech
 Industrial Development Park, Huizhou, Guangdong,
 China

Tel:0752-3219929
 Fax:0752-3219929
<http://www.kst-cert.com>

Technical Compliance Statement

Certificate No.: KST240304L008Q01

Report No.: KST240304L008Q01

The following product has been tested by us with the listed standards and found in Compliance with the council LVD directive 2014/35/EU. It is demonstrative for the Compliance with this LVD Directive.

Holder: DONGGUAN BAIYOU ELECTRONIC CO LTD
Address: 2F A Building, Wufeng Industrial, Jintan Road, Danwu Shijie Town, Dongguan, Guangdong
Product: USB CHARGER
Model Name: BY213-TD04-C
Trade Name: N/A

Test Standard	
EN 62368-1:2014+A11:2017	Audio/video, information and communication technology equipment Part 1: safety requirements



Signature: 

Name:

Tony Xu

Position:

General Manager

Date:

Apr. 26, 2024



The statement is based on single evaluation of one sample of above mentioned product. It does not imply an assessment of the whole production and does not permit the use of the test lab. Logo.



KeySense Testing & Certification International Co., Ltd.
 1-3F, Lab Building, No.29 District, Zhongkai Hi-Tech
 Industrial Development Park, Huizhou, Guangdong,
 China

Tel:0752-3219929
 Fax:0752-3219929
<http://www.kst-cert.com>

Technical Compliance Statement

Certificate No.: KST240304E008Q01

Report No.: KST240304E008Q01

The following product has been tested by us with the listed standards and found in Compliance with the council EMC directive 2014/30/EU. It is demonstrative for the Compliance with this EMC Directive.

Holder: DONGGUAN BAIYOU ELECTRONIC CO LTD

Address: 2F A Building, Wufeng Industrial, Jintan Road, Danwu Shijie Town, Dongguan, Guangdong

Product: USB CHARGER

Model Name: BY213-TD04-C

Trade Name: N/A

Test Standard	
EN 55032:2015+A1:2020	Electromagnetic compatibility of multimedia equipment – Emission requirements
EN IEC 61000-3-2:2019+A1:2021	Electromagnetic Compatibility (EMC) Part 3-2:Limits-Limits for harmonic current emissions(equipment input current $\leq 16A$ per phase)
EN 61000-3-3:2013+A2:2021	Electromagnetic Compatibility(EMC) Part 3-3:Limits-limitation of voltage changes, voltage fluctuations and flicker in public low-voltage supply systems, for equipment with rated current $\leq 16A$ per phase and not subject to conditional connection
EN 55035:2017+A11:2020	Electromagnetic compatibility of multimedia equipment – Immunity requirements



Signature: 

Name: Jack.Li

Position: Supervisor

Date: April 26, 2024

The statement is based on single evaluation of one sample of above mentioned product. It does not imply an assessment of the whole production and does not permit the use of the test lab. Logo.

Verification of Compliance

Verification No.:	MK25040228P01-E02
Name and address of Applicant:	Zhongshan Bainian manlei Lighting Technology Co., Ltd 2F, No.8 2nd Alley ,1 Street, Sansha Paifang Road, Henglan Town,Zhongshan City,Guangdong
Name and address of Manufacturer	Zhongshan Bainian manlei Lighting Technology Co., Ltd 2F, No.8 2nd Alley ,1 Street, Sansha Paifang Road, Henglan Town,Zhongshan City,Guangdong
Product name:	RV reading light
Rated:	5V 3W
Product model(s):	MY-995-A
Product trademark:	N/A

This verification confirms that the product meets the requirements of the following standard.

The conformity was demonstrated based on following standard(s) listed by European Commission as harmonized with EMC Directive 2014/30/EU.

EN IEC 55015:2019+A11:2020

EN IEC 61547:2023

EN IEC 61000-3-2:2019+A1:2021

EN 61000-3-3:2013/A2:2021

The verification has been carried out in accordance with individual rules and conditions agreed with the applicant. Evaluation has been carried out in accordance with:

Test report(s) No.: MK25040228P01-E02

Test conducted by: TMC Testing Services (Shenzhen) Co., Ltd.

Verification issue date: May 07, 2025

Notes:

This verification refers to the above mentioned product and its conformity in regards of above mentioned standard(s) was proven on test sample.

This verification does not imply meeting all essential requirements, assessment of the series-production or any other restricted Notified Bodies conformity assessment procedure appropriate for the product.

This verification holder shall use this verification in connection to verification of conformity and technical data relevant for the product the verification was issued.

TMC Testing Services (Shenzhen) Co., Ltd.

t:86-755-86642861 cert@tmc-lab.com www.tmc-lab.com

1st Floor, Block A1, Zone A, Xinshidai Gongrong Industrial Park, No. 2, Shihuan Road, Shiyan Street, Baoan District, Shenzhen, China



Verification of Compliance

Verification No.:	MK24110251P01-C02
Name and address of Applicant:	Zhongshan Bainian manlei Lighting Technology Co., Ltd 2F, No.8 2nd Alley ,1 Street, Sansha Paifang Road, Henglan Town,Zhongshan Ctiy,Guangdong
Name and address of Manufacturer:	Zhongshan Bainian manlei Lighting Technology Co., Ltd 2F, No.8 2nd Alley ,1 Street, Sansha Paifang Road, Henglan Town,Zhongshan Ctiy,Guangdong
Product name:	RV reading light
Product model(s):	MY-995-A
Product trademark:	N/A

This verification confirms that the product meets the requirements of the following standard. The conformity was demonstrated based on following standard(s) listed by European Commission as harmonized with Directive RoHS 2.0 Directive (EU) 2015/863 and (EU)2017/2102 amending Annex II to Directive 2011/65/EU

IEC 62321-1:2013	IEC 62321-3-1:2013
IEC 62321-4:2013/AMD1:2017	IEC 62321-5:2013
IEC 62321-6:2015	IEC 62321-7-1:2015
IEC 62321-7-2:2017	IEC 62321-8:2017
IEC 62321-2:2014	

The verification has been carried out in accordance with individual rules and conditions agreed with the applicant. Evaluation has been carried out in accordance with:

Test report(s) No.:	MK24110251P01-C02
Test conducted by:	TMC Testing Services (Shenzhen) Co., Ltd.
Verification issue date:	December 06, 2024

Notes:

This verification refers to the above mentioned product and its conformity in regards of above mentioned standard(s) was proven on test sample.

This verification does not imply meeting all essential requirements, assessment of the series-production or any other restricted Notified Bodies conformity assessment procedure appropriate for the product.

This verification holder shall use this verification in connection to verification of conformity and technical data relevant for the product the verification was issued.

TMC Testing Services (Shenzhen) Co., Ltd.

t:86-755-86642861 cert@tmc-lab.com www.tmc-lab.com

1st Floor, Block A1, Zone A, Xinshidai Gongrong Industrial Park, No. 2, Shihuan Road, Shiyuan Street, Baoan District, Shenzhen, China

