

Montageanleitung | Instructions de montage Assembly Instructions | Instrucciones de montaje

SKU: N623P458612/N623P458613/N623P458614(180*200CM)

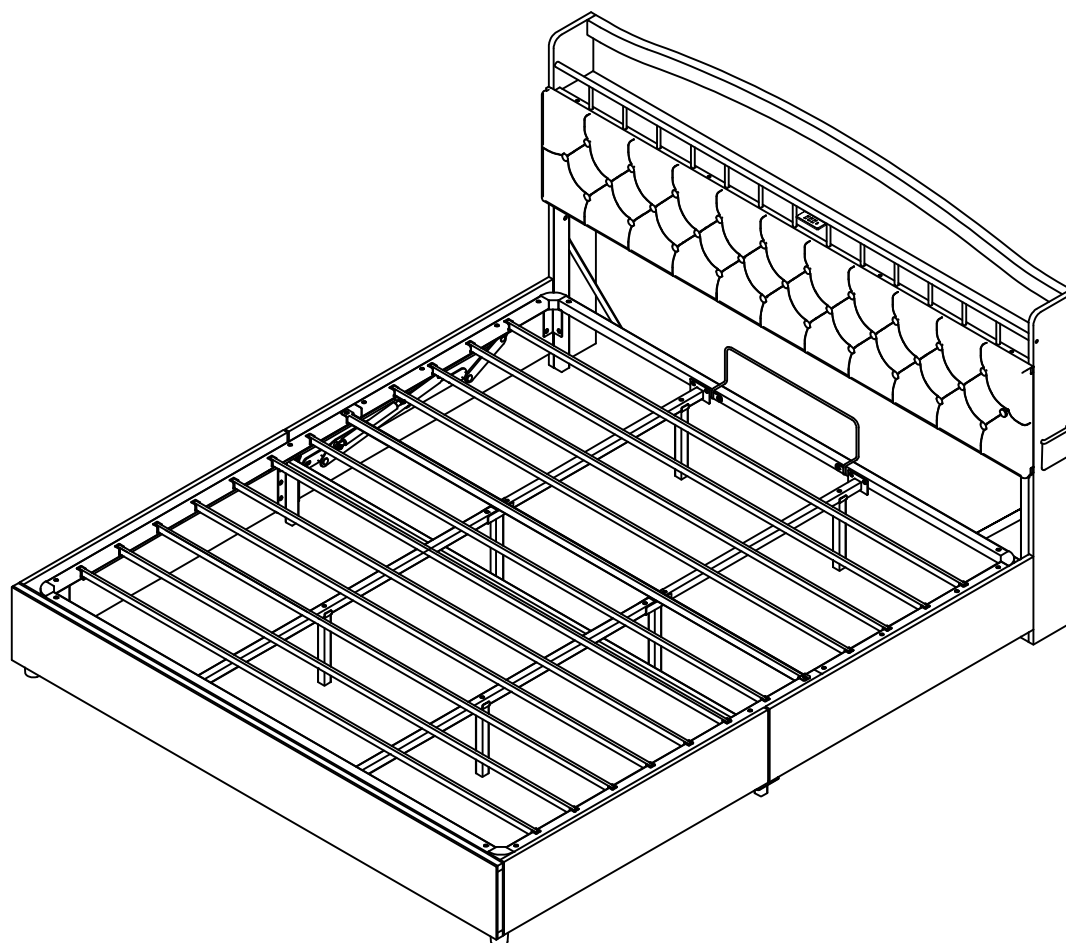

UK CA



FR
Cet appareil,
ses cordons,
et batterie
se recyclent

À DÉPOSER
EN MAGASIN

OU

À DÉPOSER
EN DÉCHÈTERIE

Points de collecte sur www.quefairedemesdechets.fr
Privilégiez la réparation ou le don de votre appareil !

CE



- GB** This set comes in 3 boxes. If you do not receive a full set of 3 boxes, please contact our customer service.
- DE** Dieses Set wird in 3 Schachteln geliefert. Wenn Sie nicht ein komplettes Set von 3 Boxen erhalten, kontaktieren Sie bitte unseren Kundenservice.
- FR** Ce set est livré en 3 boîtes. Si vous ne recevez pas un jeu complet de 3 boîtes, veuillez contacter notre service clientèle.

English

IMPORTANT ! KEEP FOR FUTURE REFERENCE : READ CAREFULLY

- To be assembled by an adult. Assembly must be checked by an adult before use
- **WARNING !** Keep all screws, small parts and plastic bags out of the reach of children
- Properly identify all parts before assembling
- Never use your item if any of its parts are broken or missing
- Should any problems arise, please contact our After Sales Service
- Manufacturer's instructions shall be followed at all times
- Care: Clean with a soft, dry doth. In case of larger stains, carefully rub with a slightly damp, non-abrasive sponge
- Do not jump on the bed

Français

IMPORTANT ! CONSERVER POUR RÉFÉRENCE ULTÉRIEURE : LIRE ATTENTIVEMENT

- Le montage doit être effectué par un adulte. Le montage doit être vérifié par un adulte avant utilisation
- **ATTENTION !** Tenir les vis, les petites pièces et les sachets en plastique hors de portée des enfants
- Identifiez correctement toutes les pièces avant de les assembler
- N'utilisez jamais votre article si l'une de ses pièces est cassée ou manquante
- En cas de problème, veuillez contacter notre service après-vente
- Les instructions du fabricant doivent être respectées à tout moment
- Entretien : nettoyer avec un chiffon doux et sec. En cas de taches plus importantes, frotter soigneusement avec une éponge non abrasive légèrement humide. légèrement humide et non abrasive
- Ne pas sauter sur le lit

Deutsch

WICHTIG ! ZUM SPÄTEREN NACHSCHLAGEN AUFBEWAHREN: SORGFÄLTIG LESEN

- Muss von einem Erwachsenen zusammengebaut werden. Der Zusammenbau muss vor dem Gebrauch von einem Erwachsenen überprüft werden
- **WARNUNG!** Bewahren Sie alle Schrauben, Kleinteile und Plastikbeutel außerhalb der Reichweite von Kindern auf
- Kennzeichnen Sie vor dem Zusammenbau alle Teile richtig.
- Benutzen Sie Ihren Artikel niemals, wenn Teile gebrochen sind oder fehlen
- Sollten Probleme auftreten, wenden Sie sich bitte an unseren Kundendienst
- Die Anweisungen des Herstellers sind stets zu befolgen
- Pflege: Mit einem weichen, trockenen Tuch reinigen. Bei größeren Flecken vorsichtig mit einem leicht feuchten, nicht scheuernden Schwamm abreiben. nicht scheuernden Schwamm
- Nicht auf das Bett springen

Italiano

IMPORTANTE PER I LETTI CON SOLLEVAMENTO A GAS E LA MANUTENZIONE

- Posizionare il materasso sopra la struttura del letto.
- Non tirare le maniglie della cinghia.
- Premere con forza per rilasciare il gas compresso.
- Controllare periodicamente tutte le viti e i fissaggi per assicurarsi che siano saldi.
- Quando si sposta il prodotto, sollevarlo con cautela.
- Pulire con un panno leggermente umido, senza usare prodotti chimici abrasivi o candeggina.
- NON permettere ai bambini di azionare il meccanismo di sollevamento.
- NON permettere ai bambini di avvicinarsi alla base di sollevamento quando si aziona il meccanismo.
- NON sostare all'interno del letto o della base di contenimento interna.
- NON sovraccaricare la base di contenimento interna.
- NON saltare sul prodotto o sulle sue parti.

Español

IMPORTANTE PARA LAS CAMAS ELEVADORAS DE GAS&MANTENIMIENTO

- Coloque el colchón sobre el somier.
- No tire de las asas de la correa.
- Presione con fuerza para liberar el gas comprimido.
- Compruebe periódicamente que todos los tornillos y fijaciones estén bien sujetos.
- Al mover el producto, levántelo con cuidado para colocarlo en su sitio.
- Limpie con un paño ligeramente humedecido; no utilice productos químicos abrasivos ni lejía.
- NO permita que los niños accionen el mecanismo de elevación.
- NO permita que los niños se acerquen a la base elevadora cuando accionen el mecanismo.
- NO se ponga de pie dentro de la cama o de la base de almacenamiento interna.
- NO sobrecargue el somier.
- NO salte sobre el producto ni sobre ninguna de sus piezas.

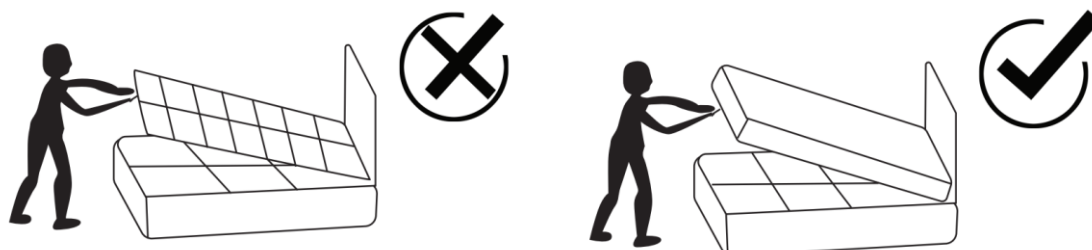

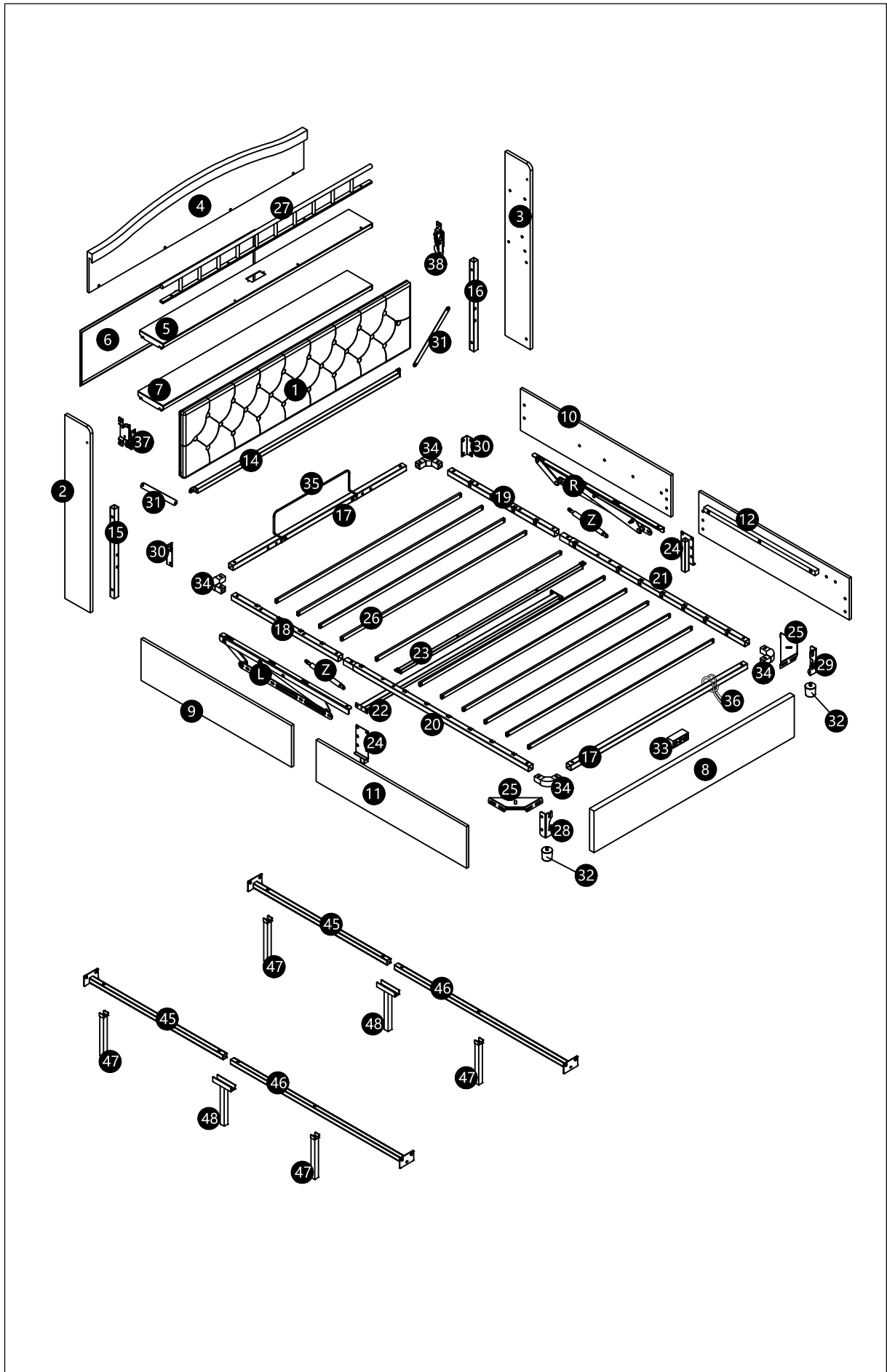



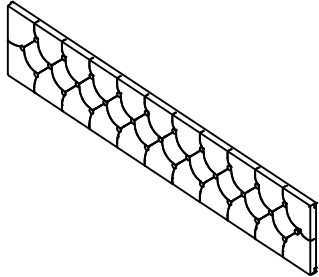
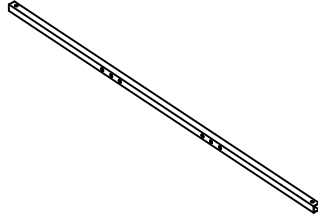
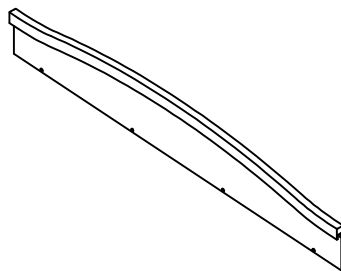
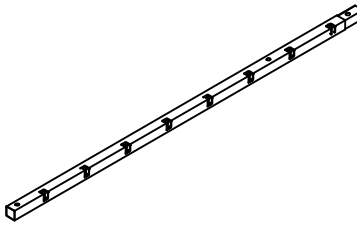
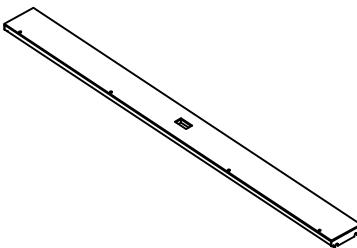
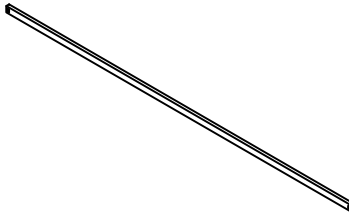
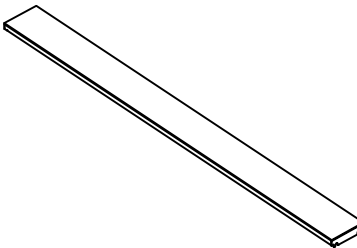
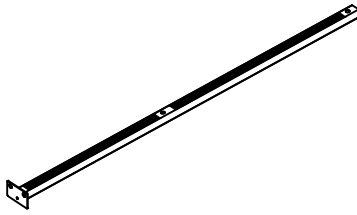
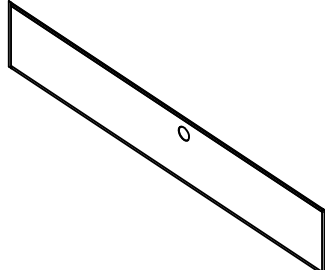
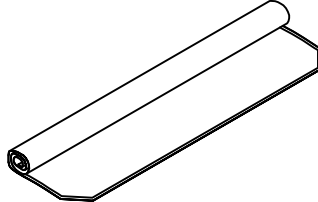
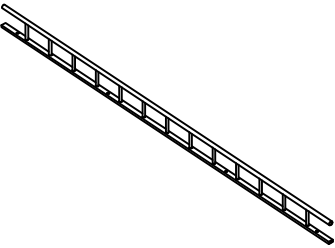
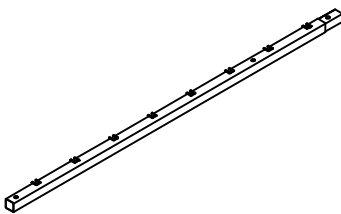



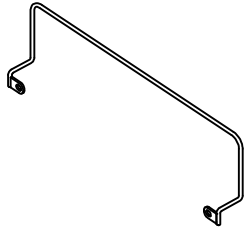

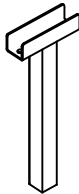
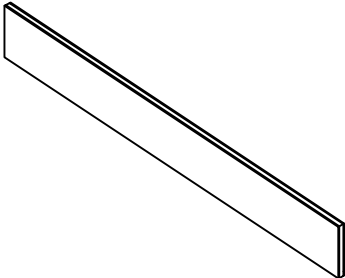
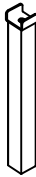
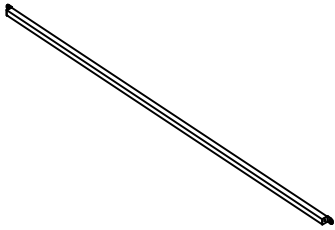
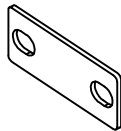
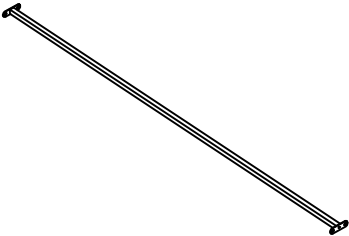
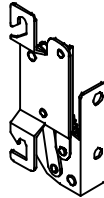
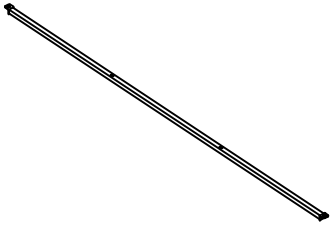



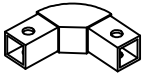

N623P458612

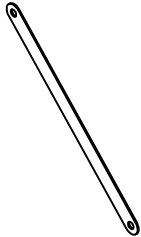
<p>1</p>		<p>X1</p>	<p>17</p>		<p>X2</p>
<p>4</p>		<p>X1</p>	<p>20</p>		<p>X1</p>
<p>5</p>		<p>X1</p>	<p>26</p>		<p>X11</p>
<p>7</p>		<p>X1</p>	<p>46</p>		<p>X2</p>
<p>6</p>		<p>X1</p>	<p>42</p>		<p>X1</p>
<p>27</p>		<p>X1</p>	<p>21</p>		<p>X1</p>

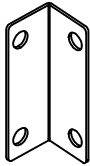
N623P458613

<p>2</p>		<p>X1</p>	<p>35</p>		<p>X1</p>
<p>3</p>		<p>X1</p>	<p>48</p>		<p>X2</p>
<p>8</p>		<p>X1</p>	<p>47</p>		<p>X4</p>
<p>14</p>		<p>X1</p>	<p>R</p>		<p>X2</p>
<p>22</p>		<p>X1</p>	<p>37</p>		<p>X1</p>
<p>23</p>		<p>X1</p>	<p>38</p>		<p>X1</p>

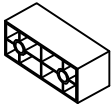
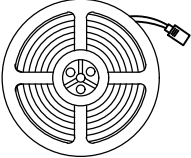
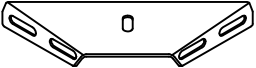



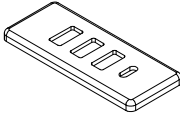
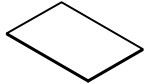

N623P458613

<p>34</p>		<p>X4</p>	<p>28</p>		<p>X1</p>
<p>31</p>		<p>X2</p>	<p>29</p>		<p>X1</p>
<p>30</p>		<p>X2</p>	<p>32</p>		<p>X2</p>
<p>24</p>		<p>X2</p>	<p>36</p>		<p>X1</p>
<p>33</p>		<p>X1</p>	<p>43</p>	 <p>light strip</p>	<p>X1</p>
<p>25</p>		<p>X2</p>	<p>44</p>	 <p>Power cord</p>	<p>X1</p>

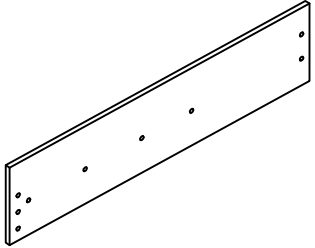

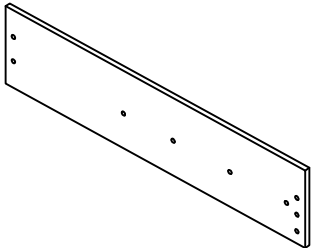

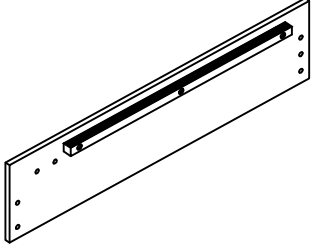
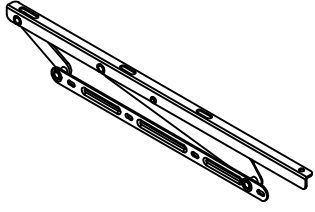
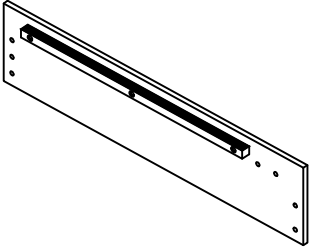
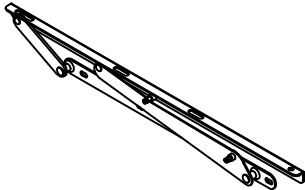
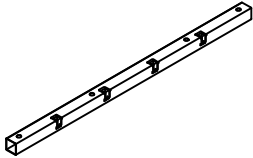
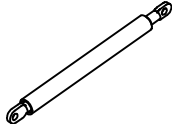

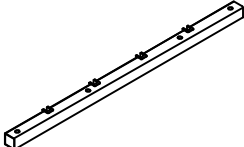

N623P458613

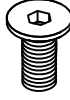
39		X1			
40		X1			
T	 Silent sticker	X2			

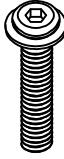

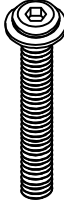
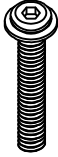
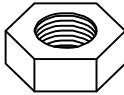
N623P458614

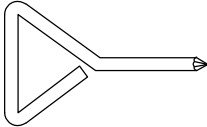
<p>9</p>		<p>X1</p>	<p>15</p>		<p>X1</p>
<p>10</p>		<p>X1</p>	<p>16</p>		<p>X1</p>
<p>11</p>		<p>X1</p>	<p>L</p>		<p>X1</p>
<p>12</p>		<p>X1</p>	<p>R</p>		<p>X1</p>
<p>18</p>		<p>X1</p>	<p>Z</p>	 <p>φ9 380mm 750N</p>	<p>X2</p>
<p>45</p>		<p>X2</p>	<p>19</p>		<p>X1</p>

N623P458613

<p>A</p>	 <p>M3*12</p>	<p>X2+1</p>	<p>G</p>	 <p>M8*20</p>	<p>X42+2</p>
<p>B</p>	 <p>M6*15</p>	<p>X4+1</p>	<p>H</p>	 <p>M8*40</p>	<p>X10+1</p>
<p>C</p>	 <p>M6*23</p>	<p>X8+1</p>	<p>J</p>	 <p>M8*48</p>	<p>X14+1</p>
<p>D</p>	 <p>M6*40</p>	<p>X2+1</p>	<p>K</p>	 <p>M8</p>	<p>X12+1</p>
<p>E</p>	 <p>M8*13</p>	<p>X12+1</p>	<p>M</p>	 	<p>X1</p>
<p>F</p>	 <p>M8*15</p>	<p>X32+2</p>	<p>N</p>	 <p>M6</p>	<p>X1</p>

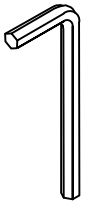
N623P458613

0	 M8	X1			
S	 M8	X1			

1

M3X12
AX2pcs

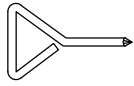

MX1pc

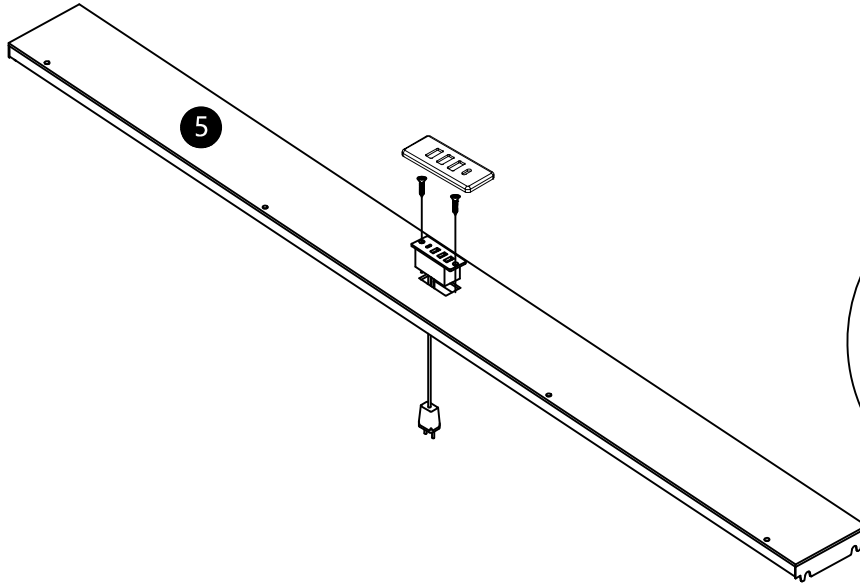
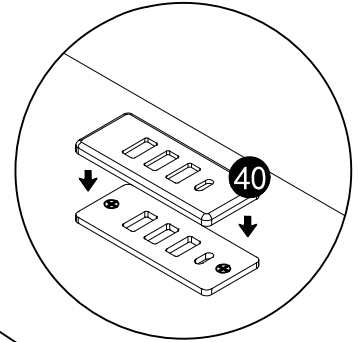
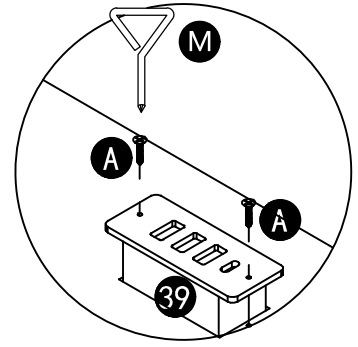

2

M6X23
CX4pcs

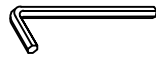

M6
NX1pc

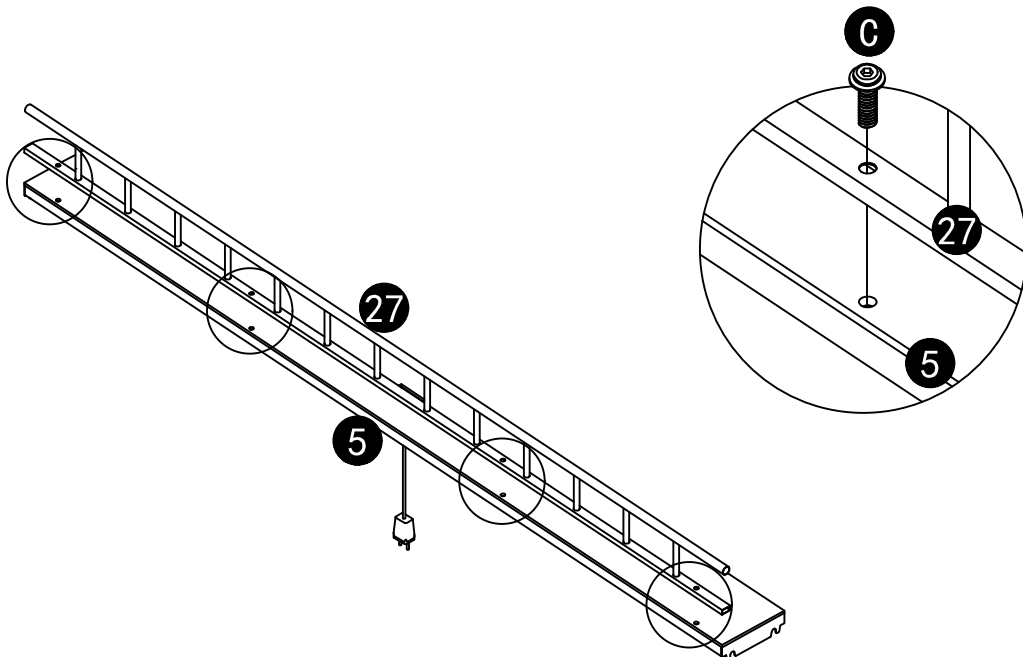

3

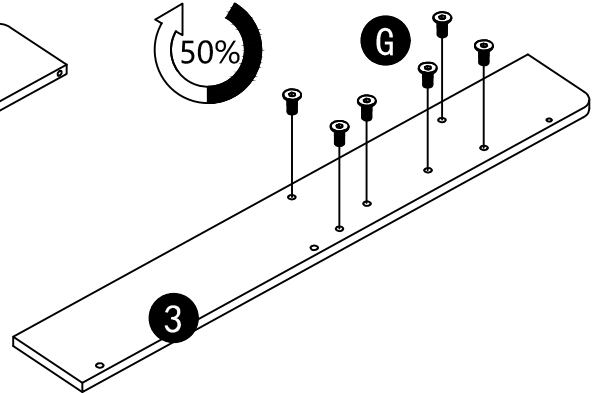
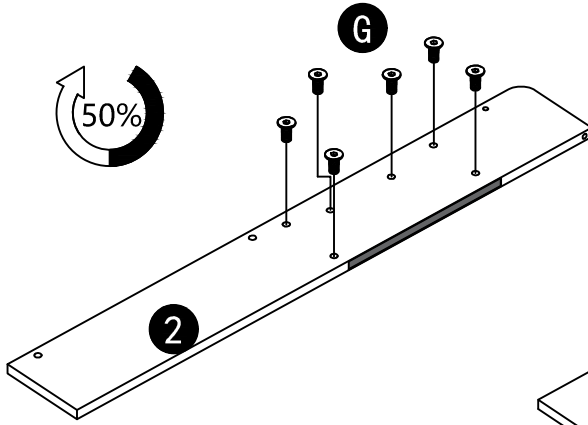
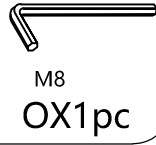

4

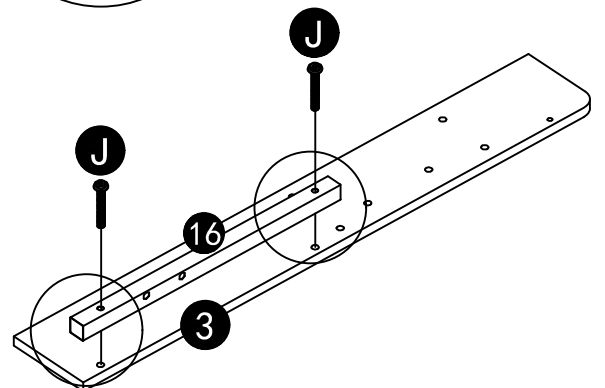
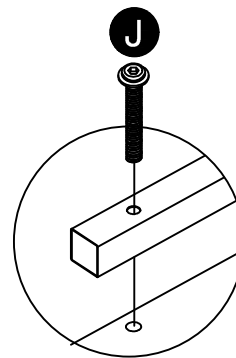
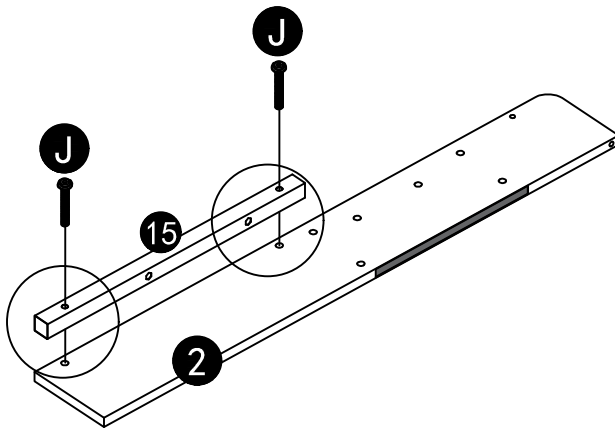
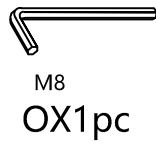
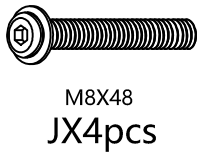

5

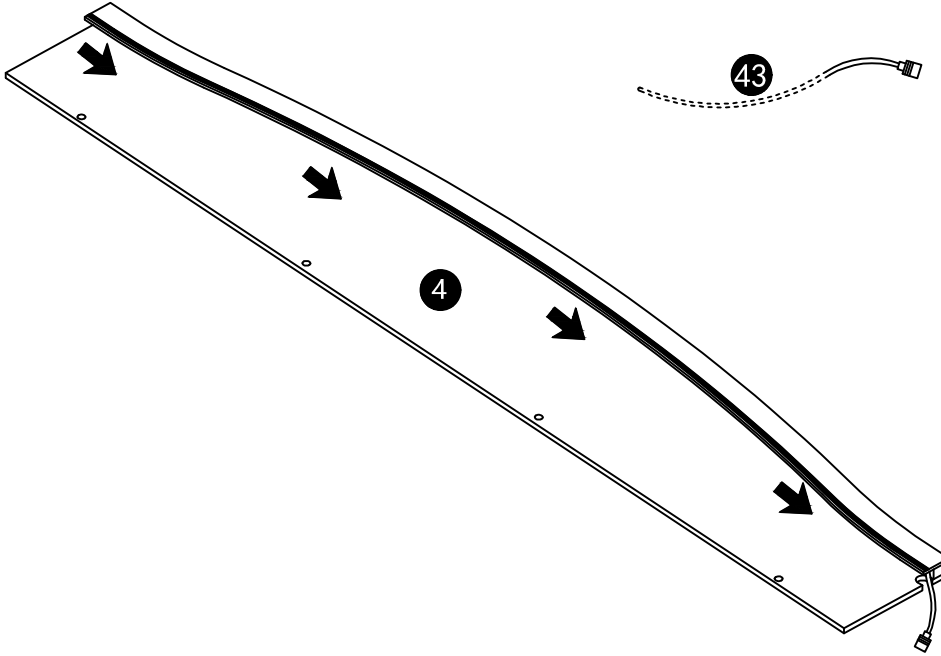
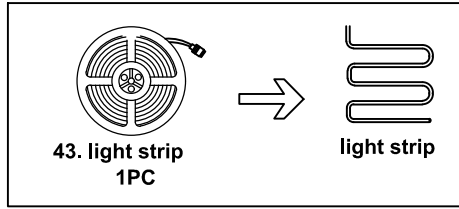

6

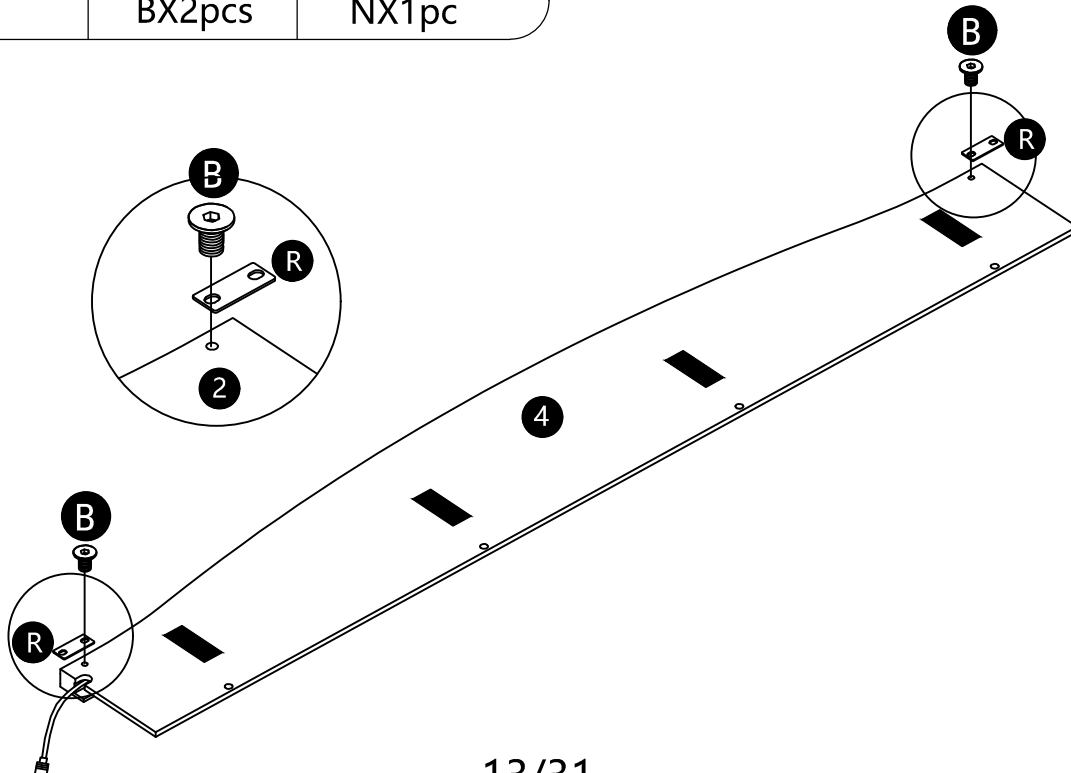
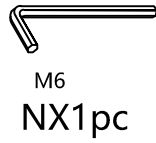

7

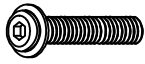

M6X40
DX2pcs

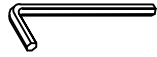

M6
NX1pc

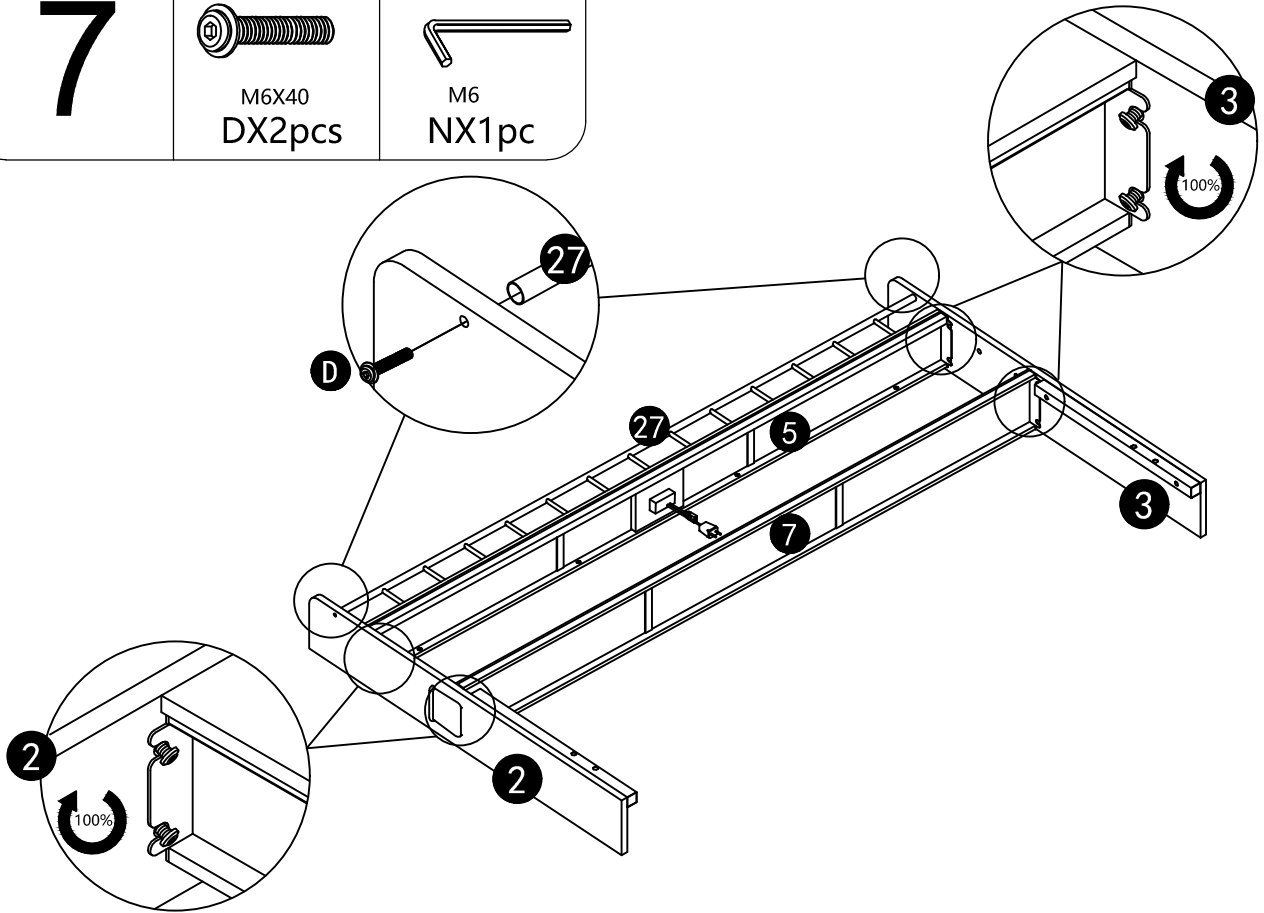

8

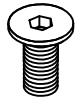

M8X20
GX6pcs



M8
OX1pc

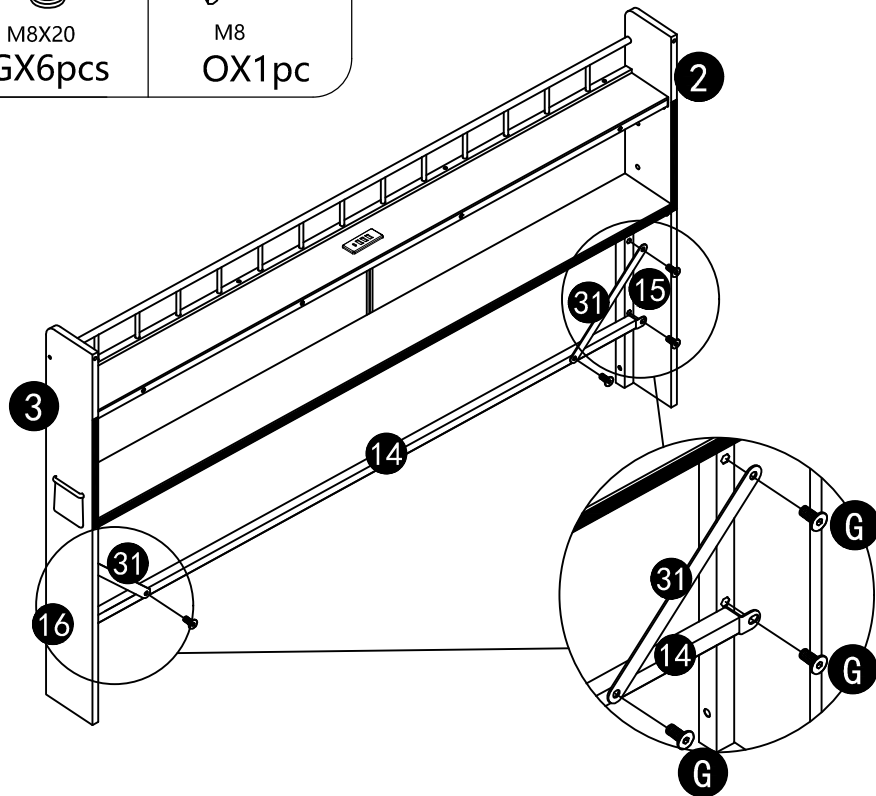

9

M6X15
BX2pcs

M6X23
CX4pcs

M6
NX1pc

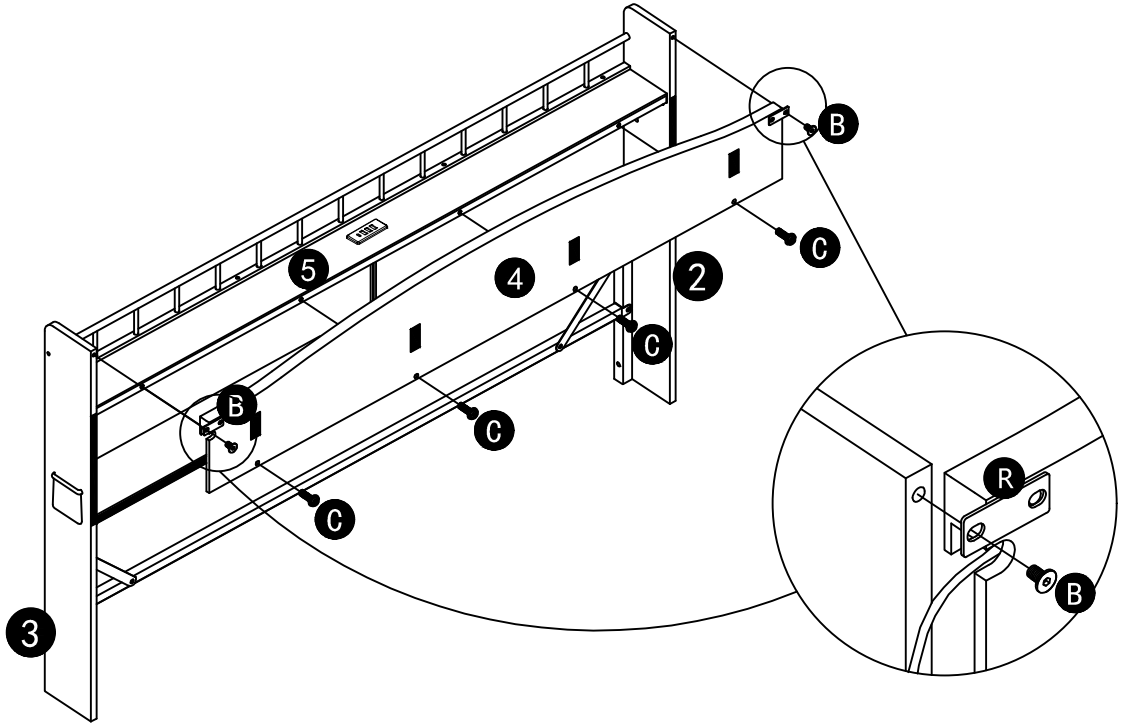

10

M8X13
EX4pcs

M8
OX1pc

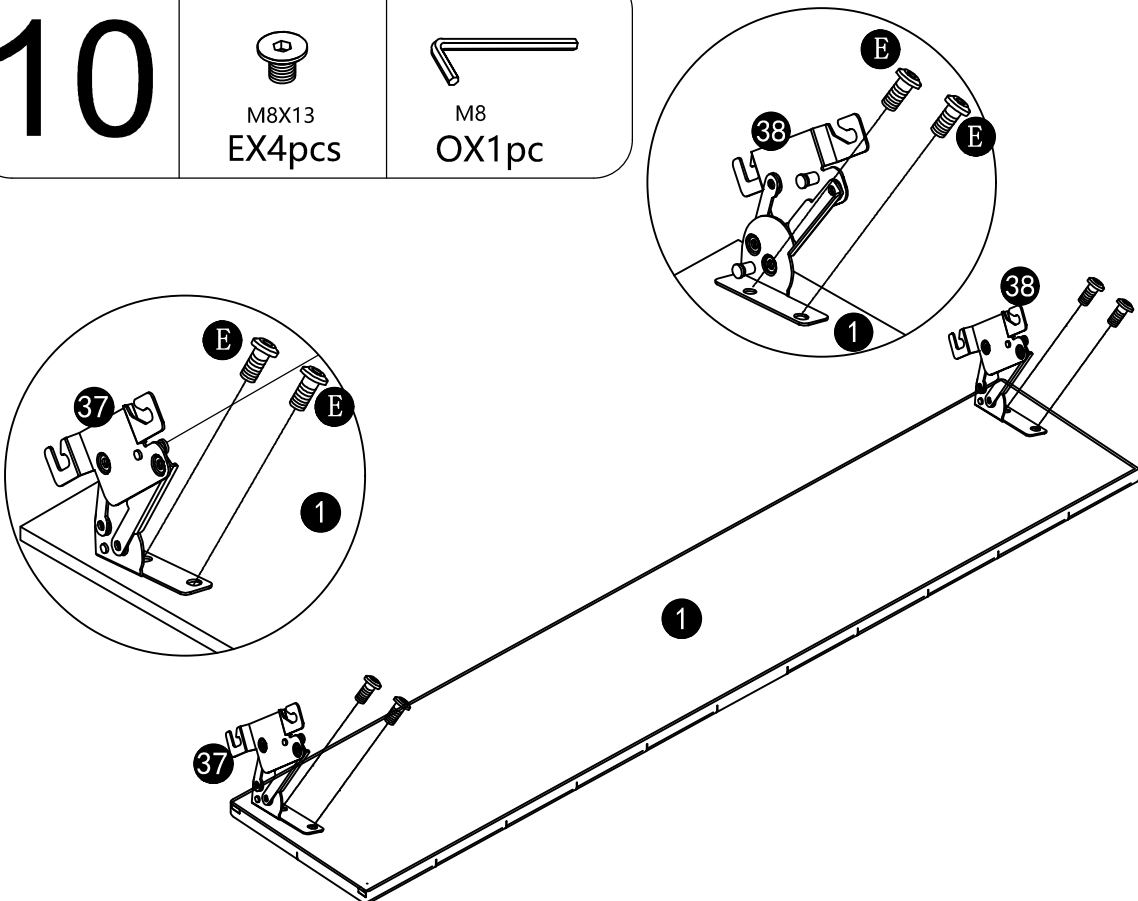

11

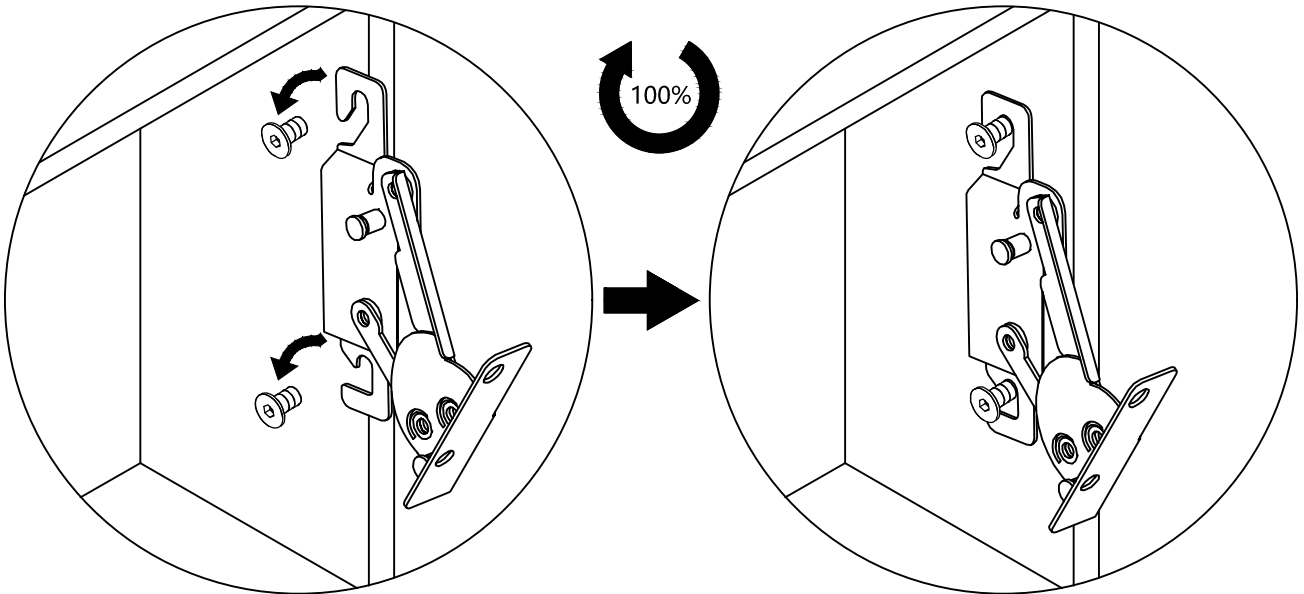
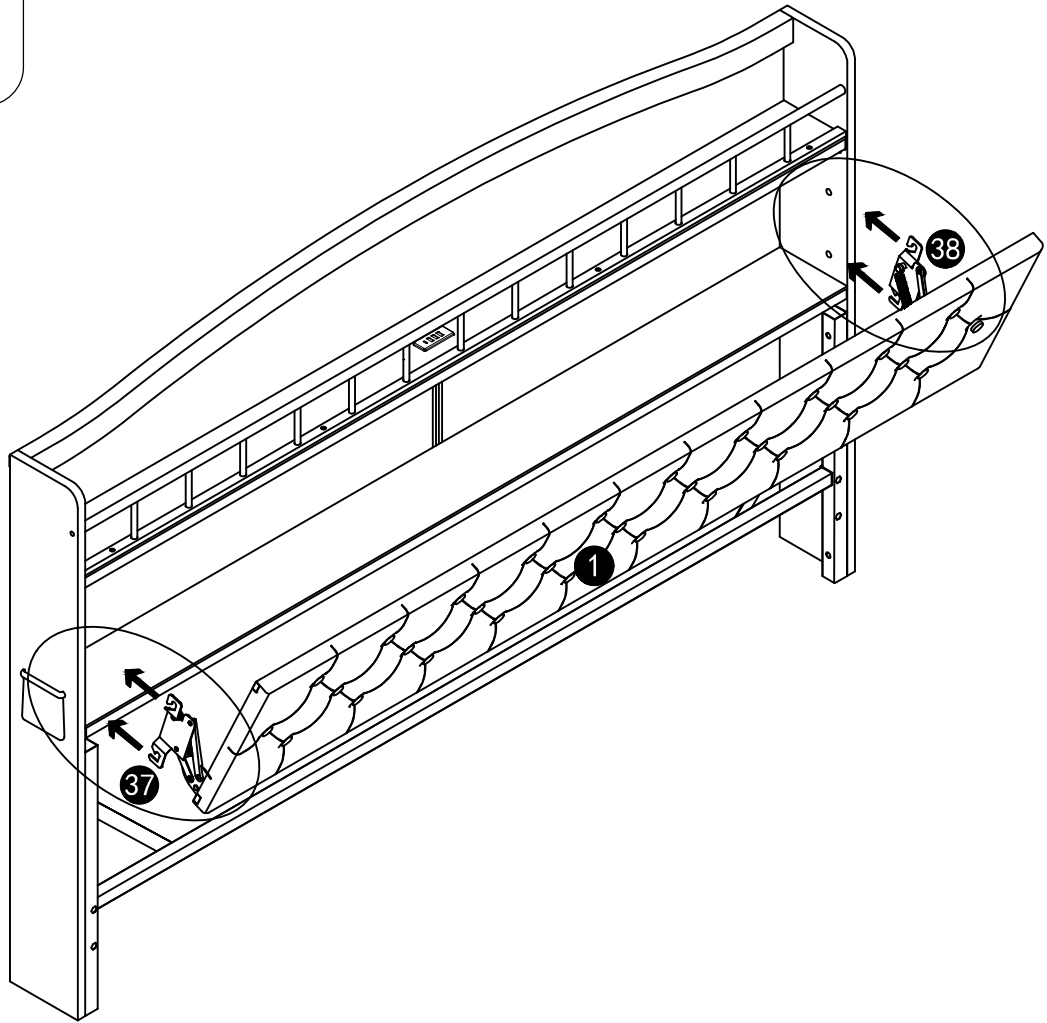

12

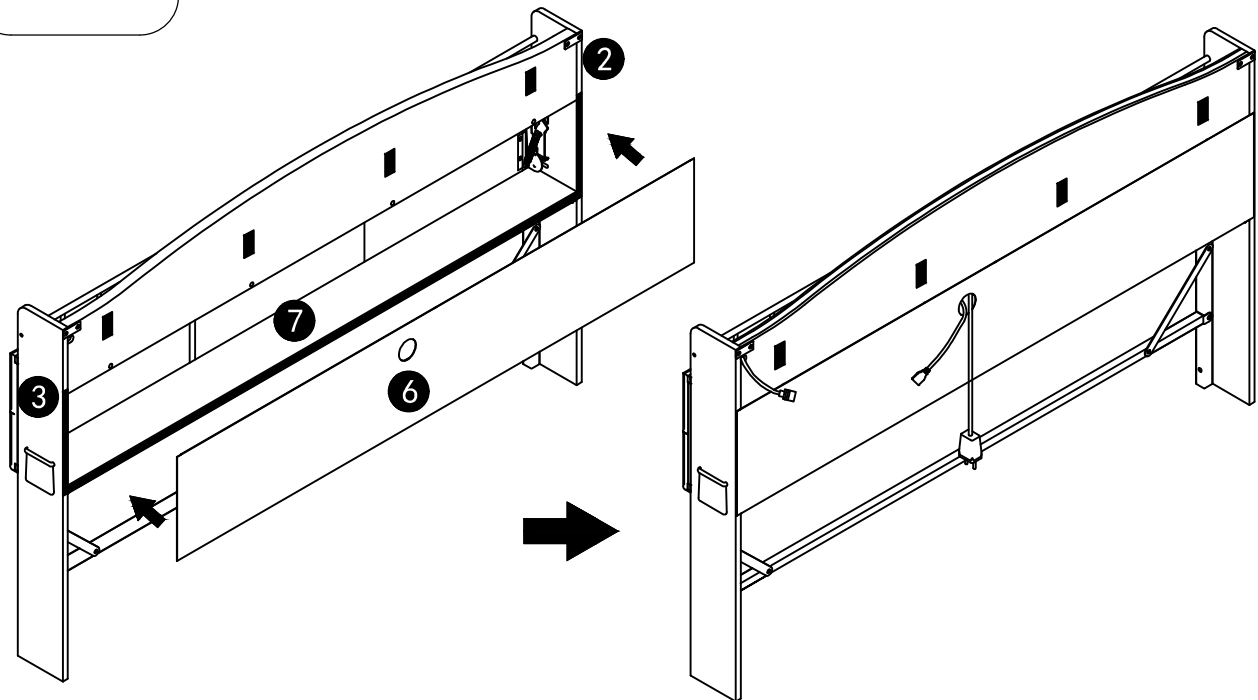

13

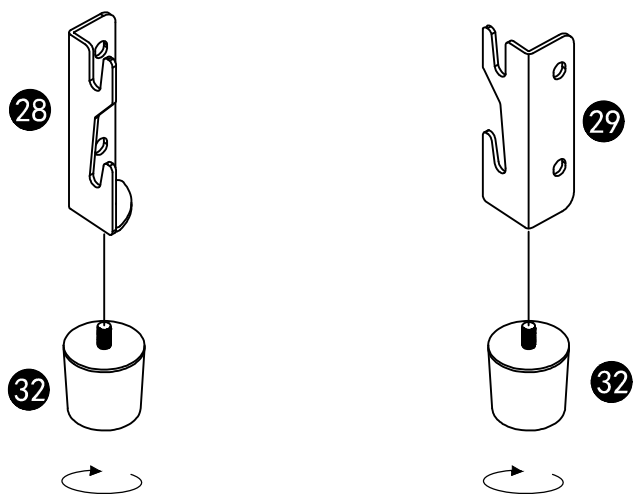

14

M8X15
FX8pcs

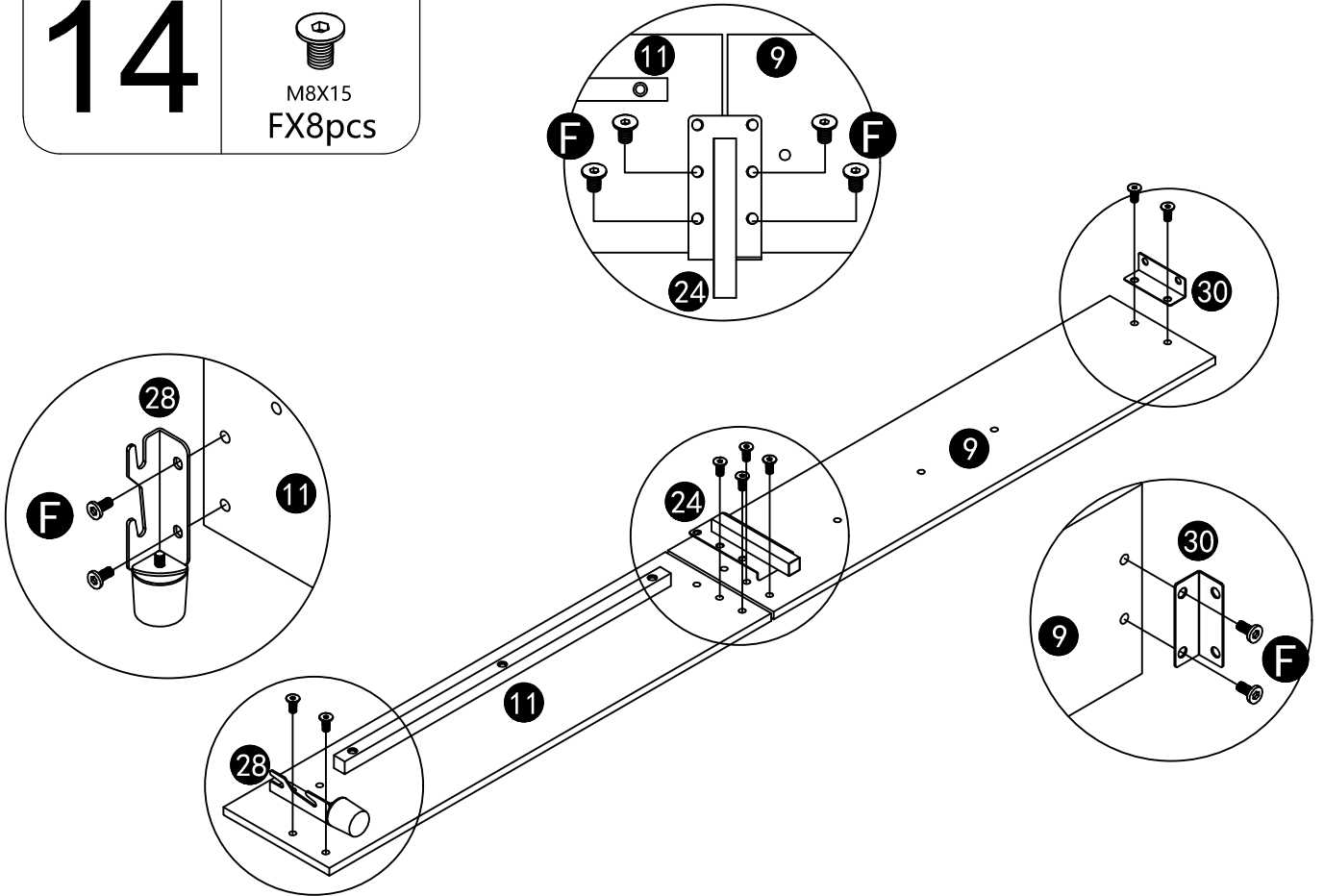

15

M8X15
FX8pcs

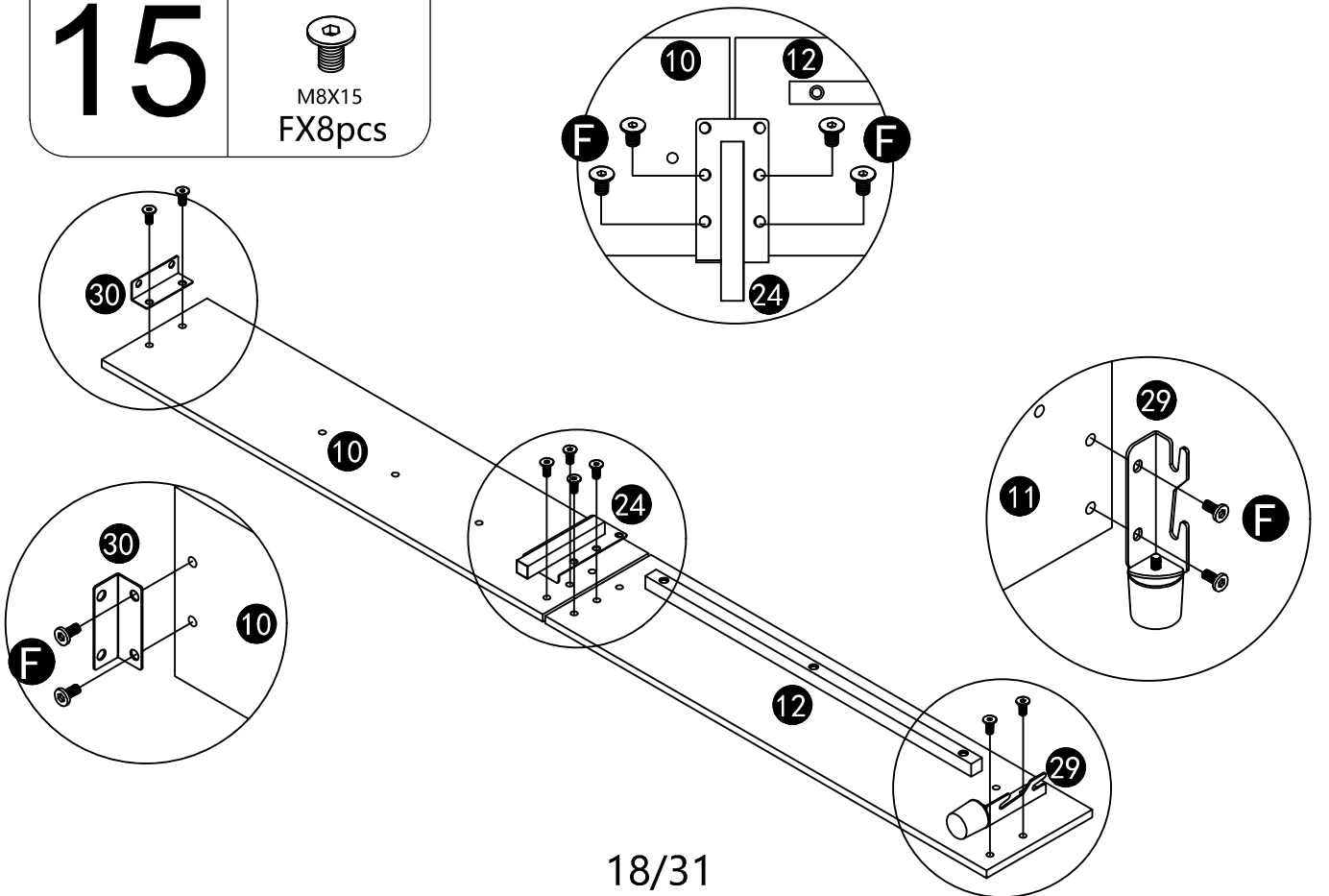

16



M8X15
FX8pcs

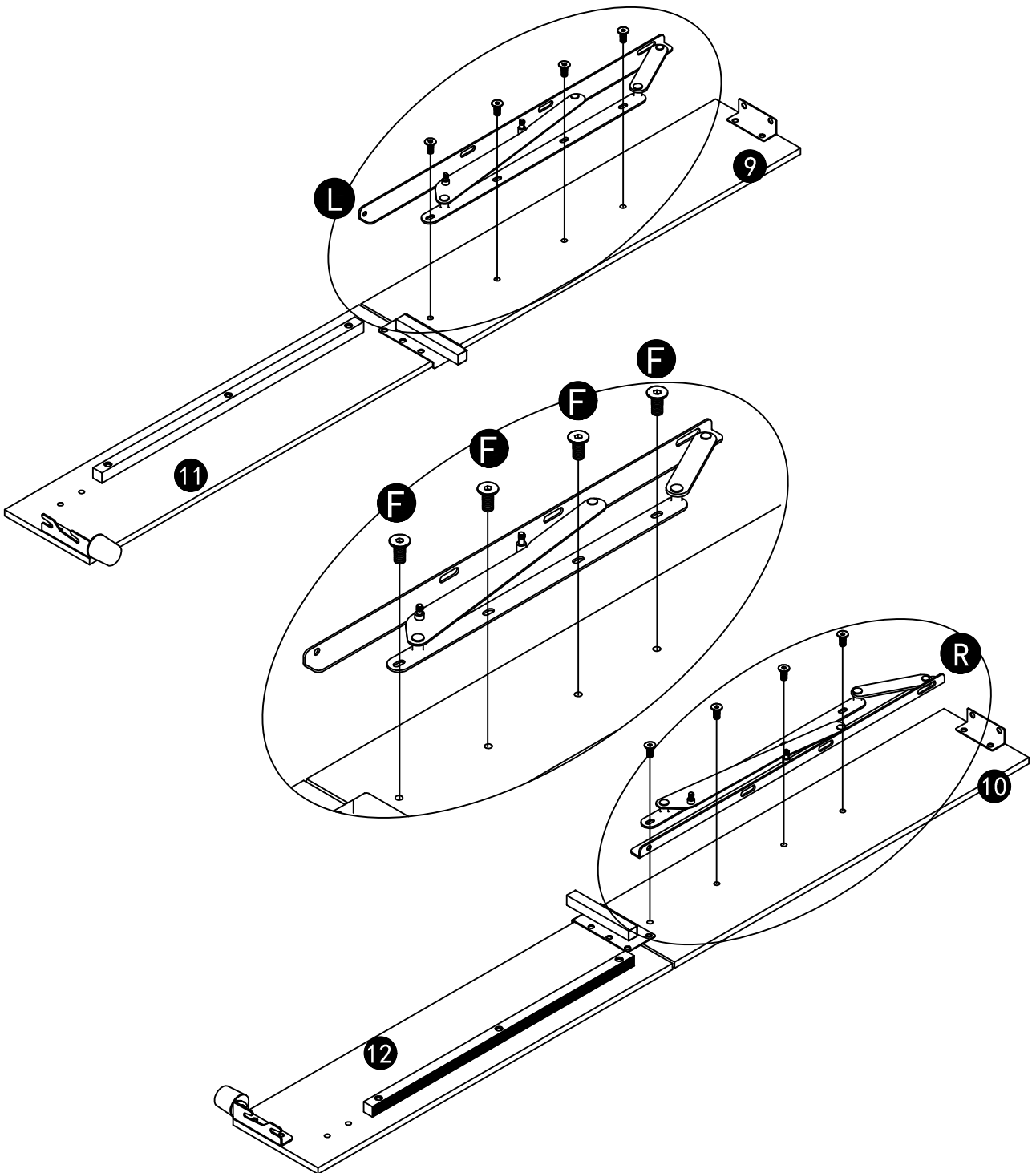
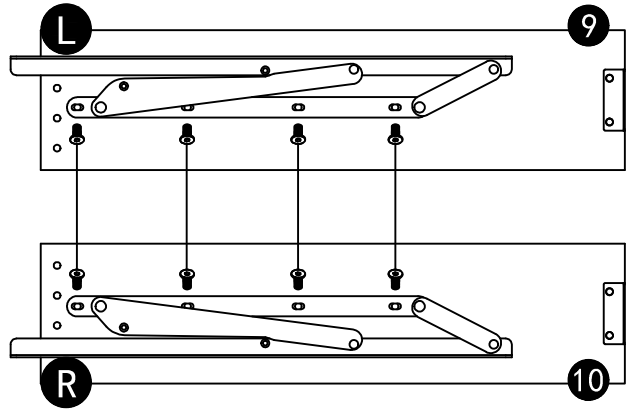

17

M8X20
GX4pcs

M8X40
HX2pcs

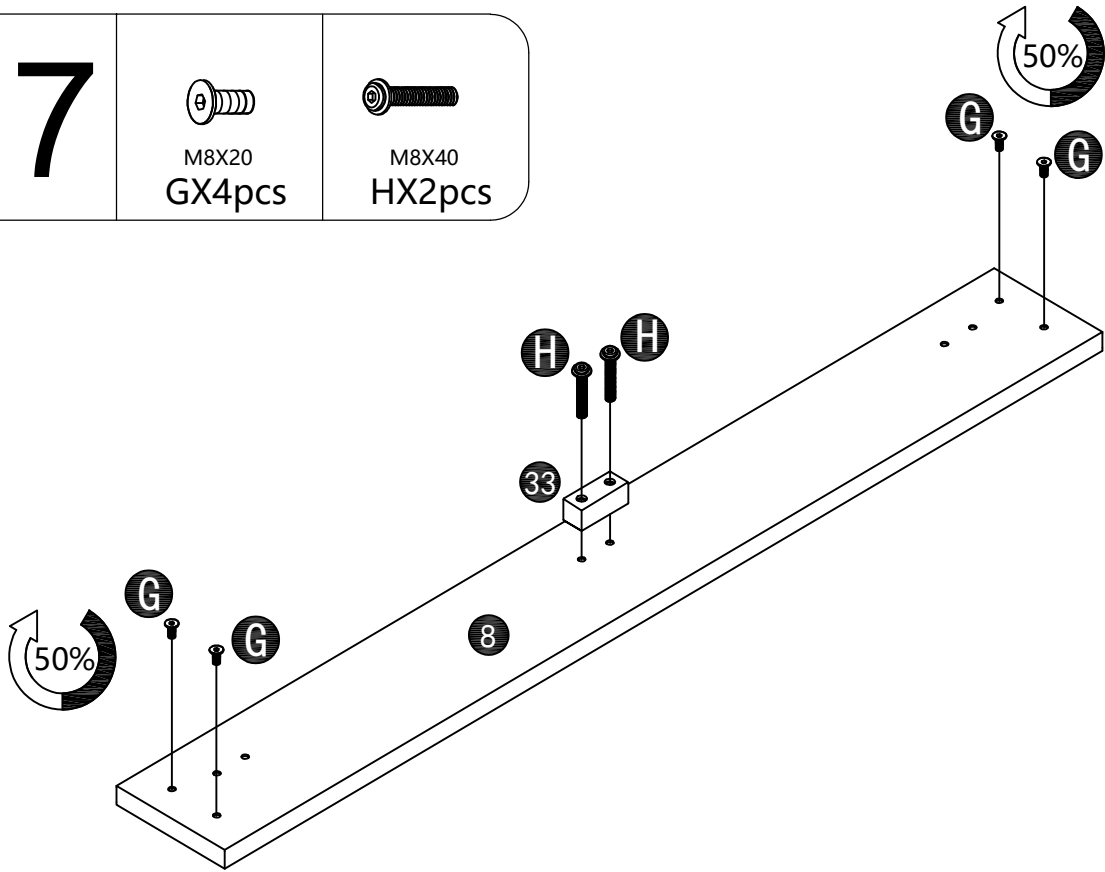

18

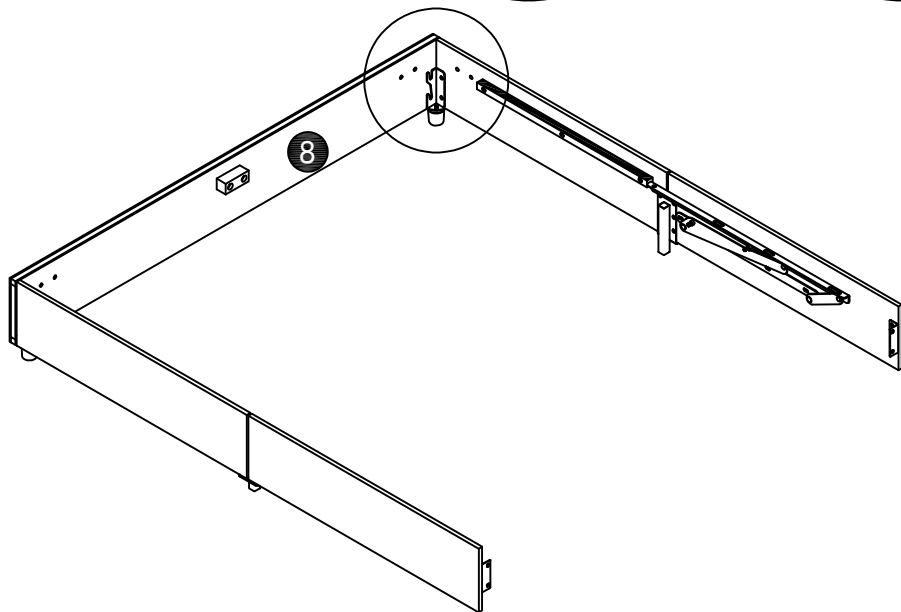
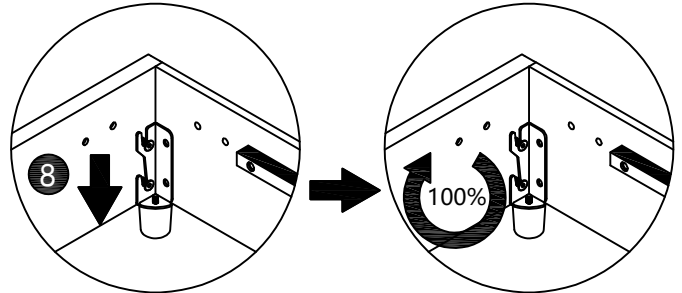

19

M8X15
FX4pcs

M8X20
GX4pcs

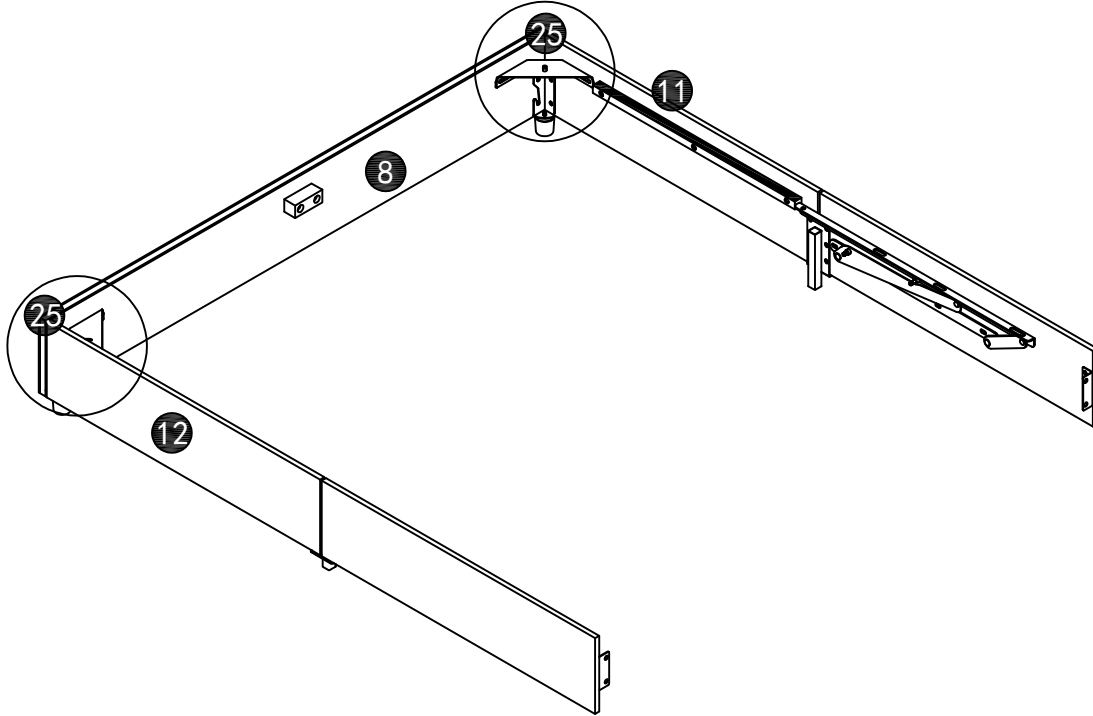
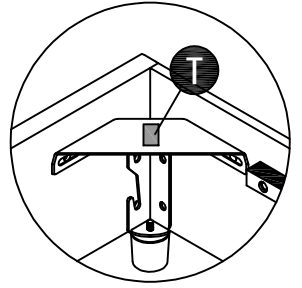
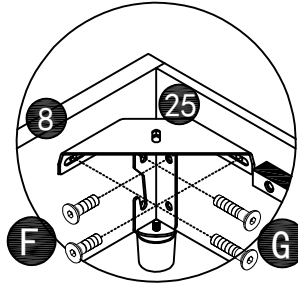

20

M8X15
FX4pcs

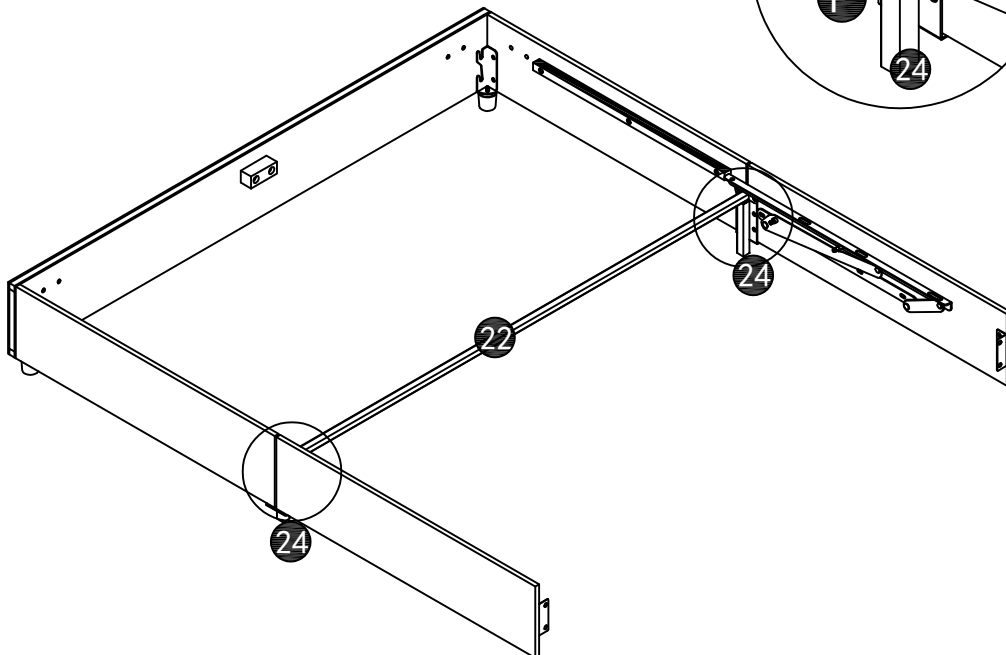
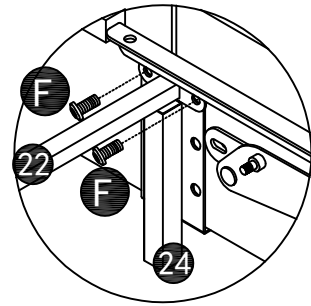

21

M8X20
GX4pcs

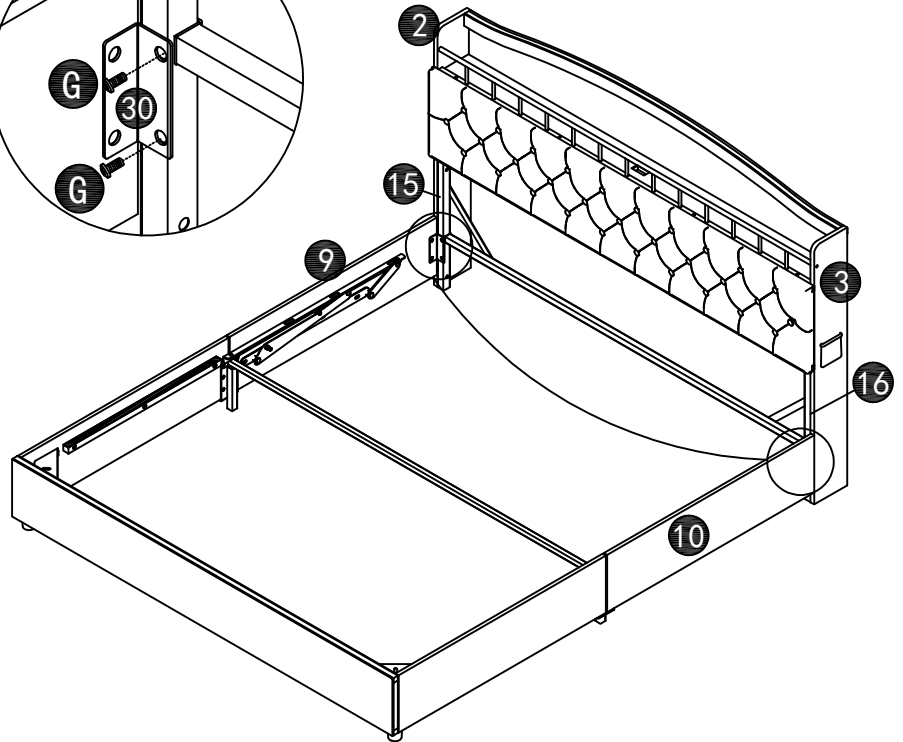
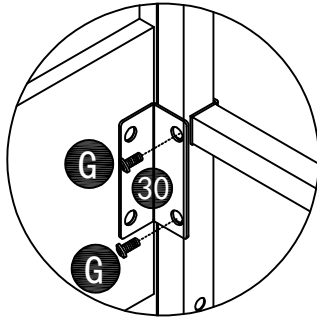

22

M8X40
HX8pcs

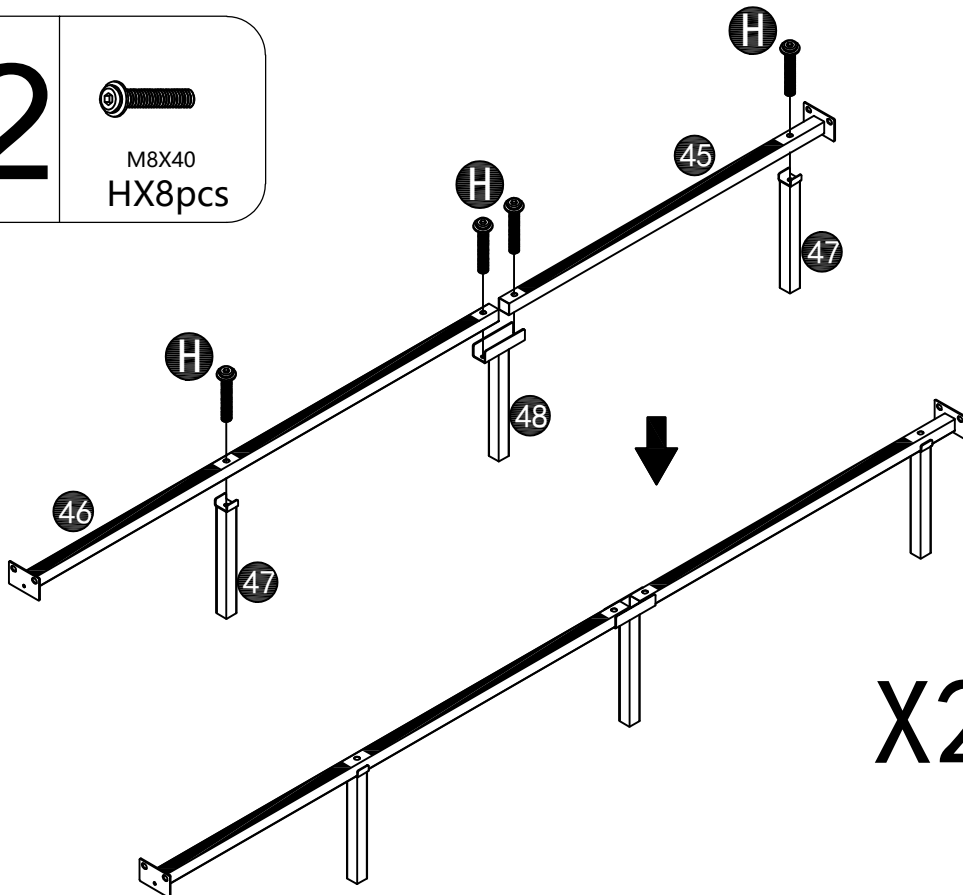

23

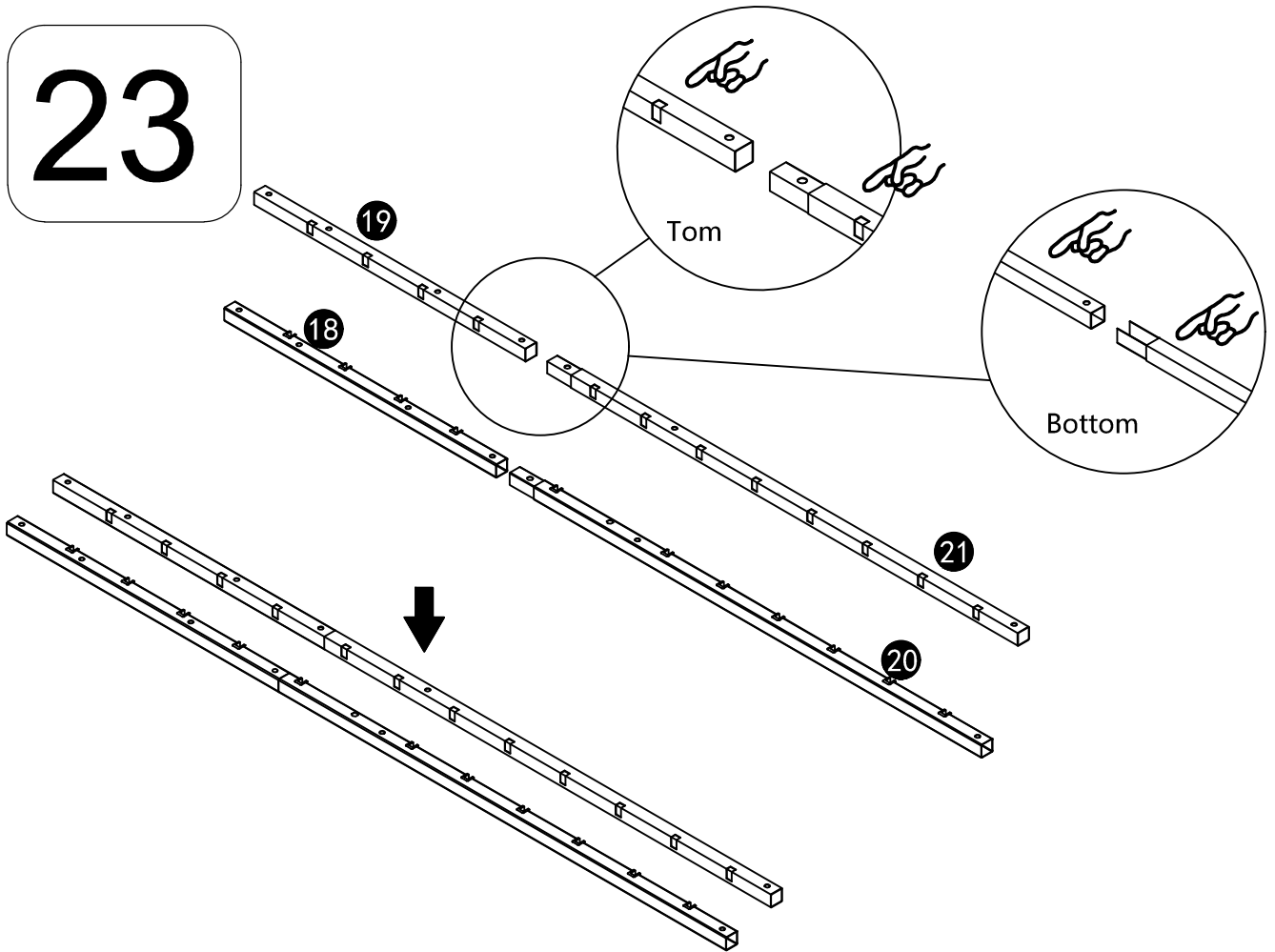

24

M8X13
EX8pcs

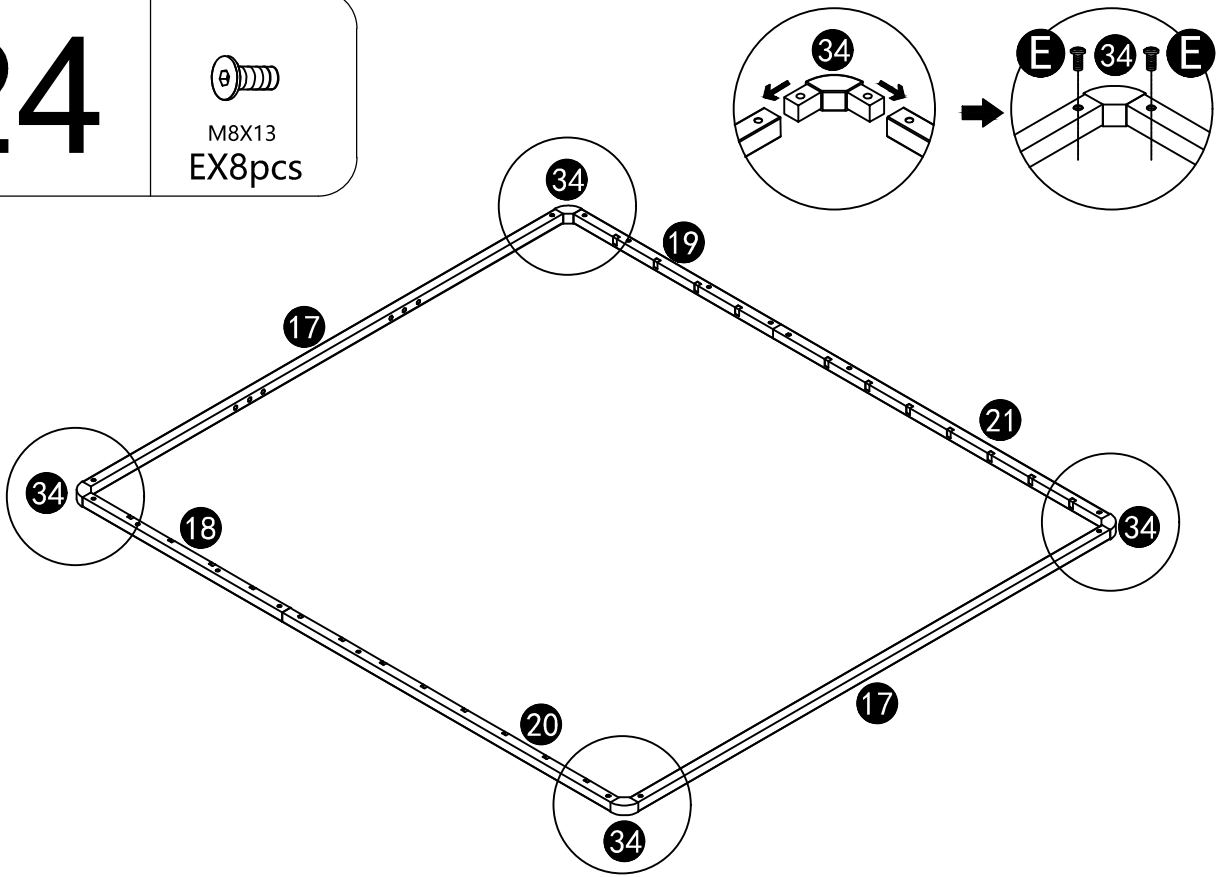

25

M8X20
GX2pcs

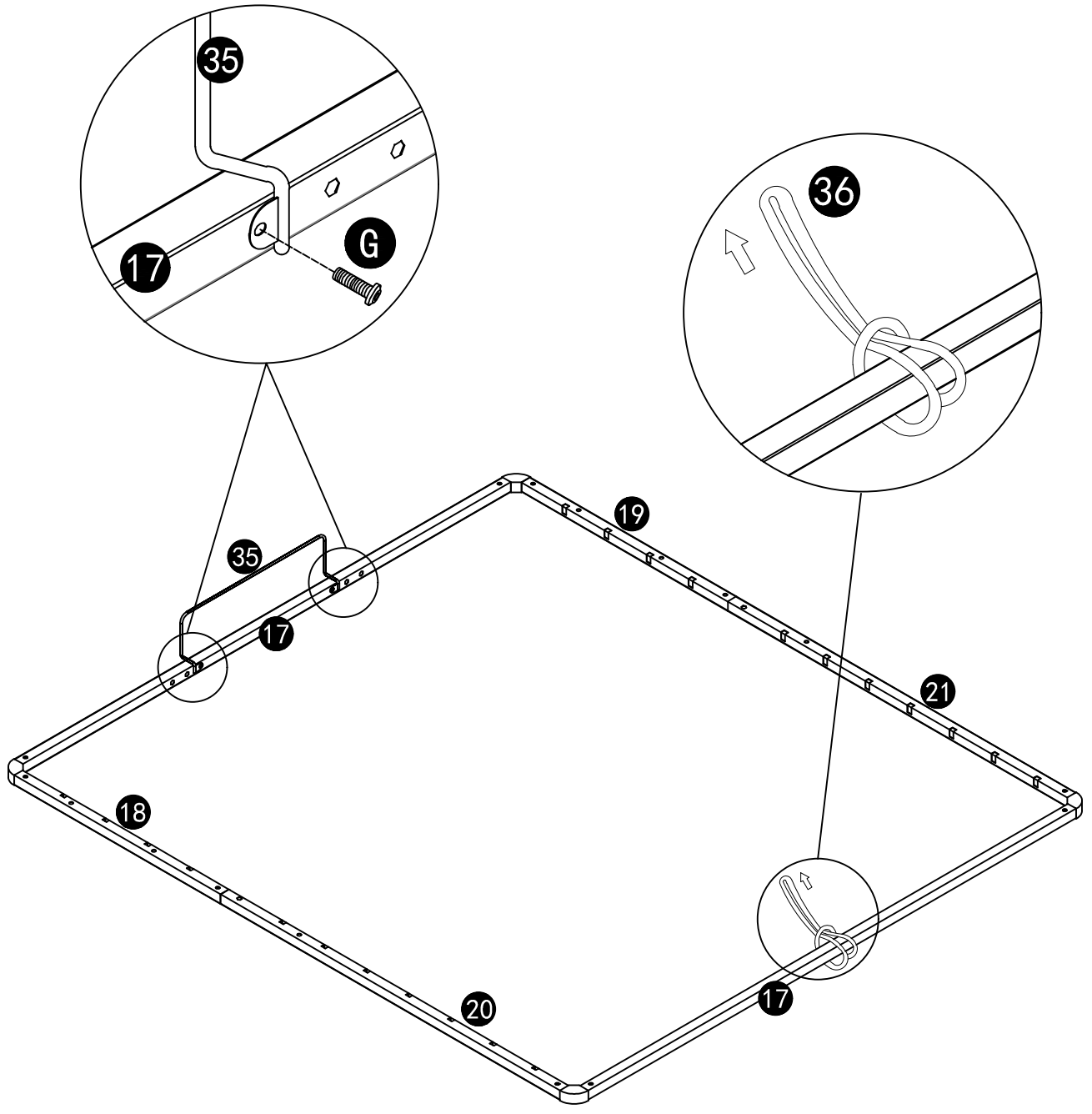

26

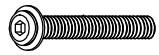

M8X48
JX8pcs



M8
KX8pcs

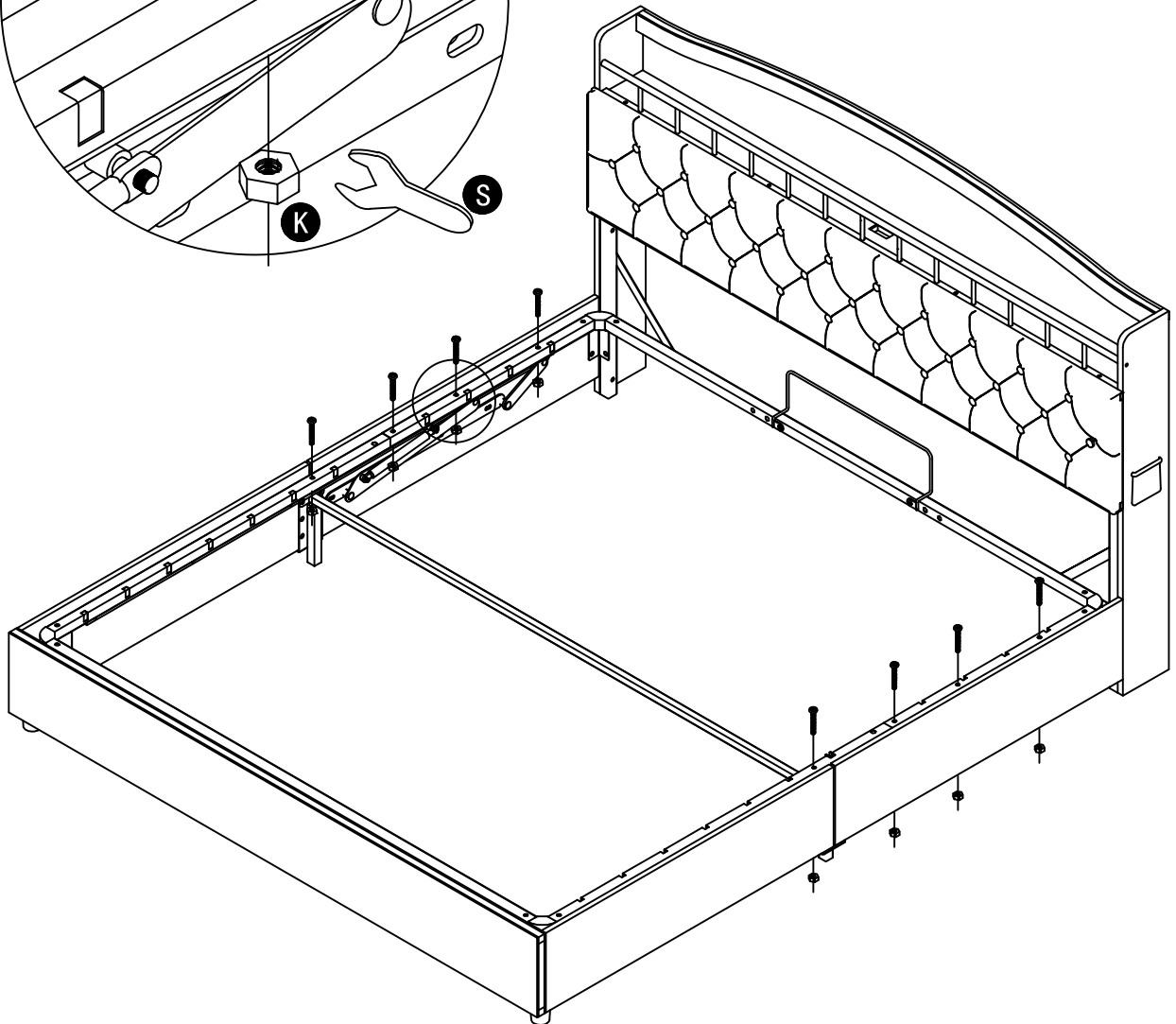
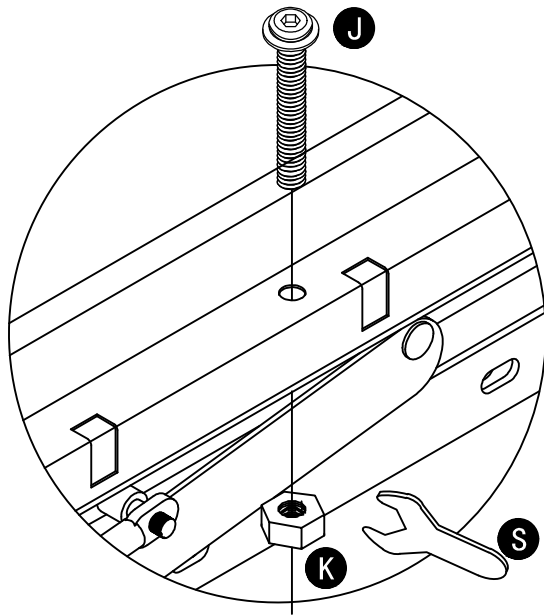

27



M8
KX4pcs

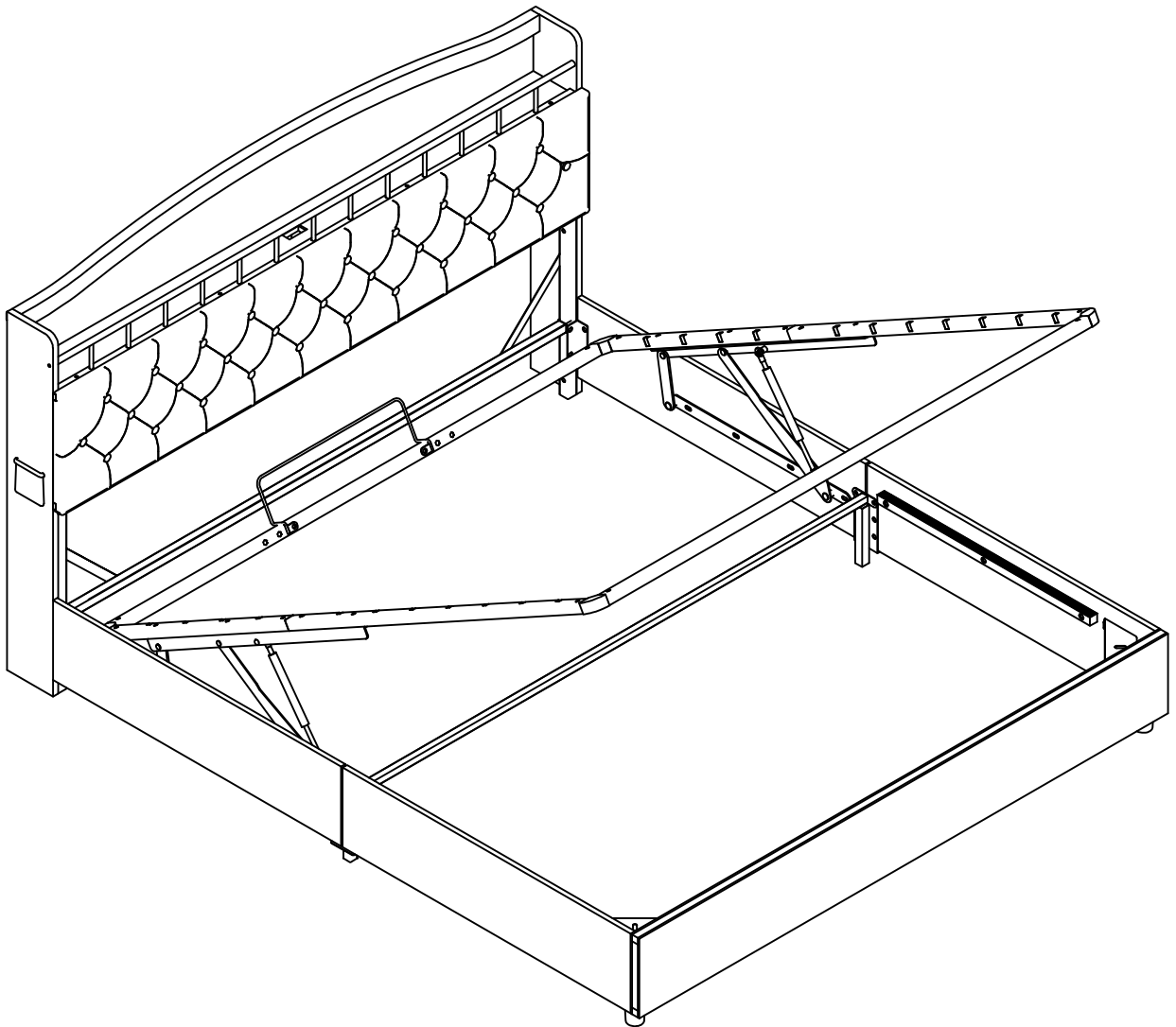
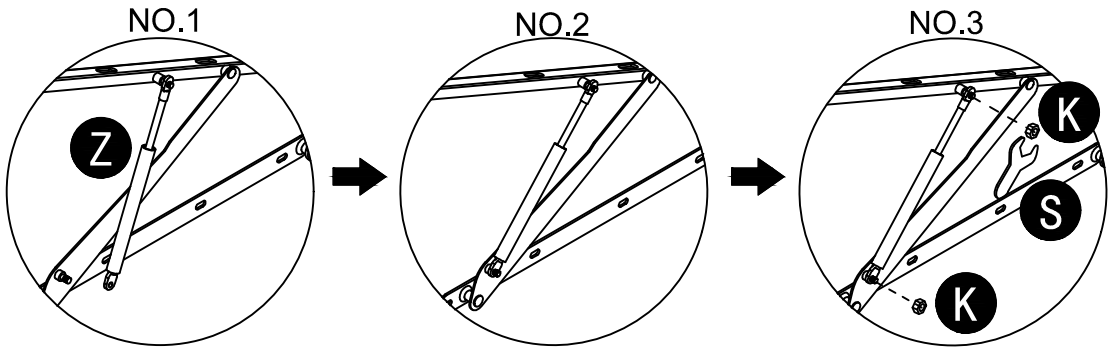

28

M8X20
GX8pcs

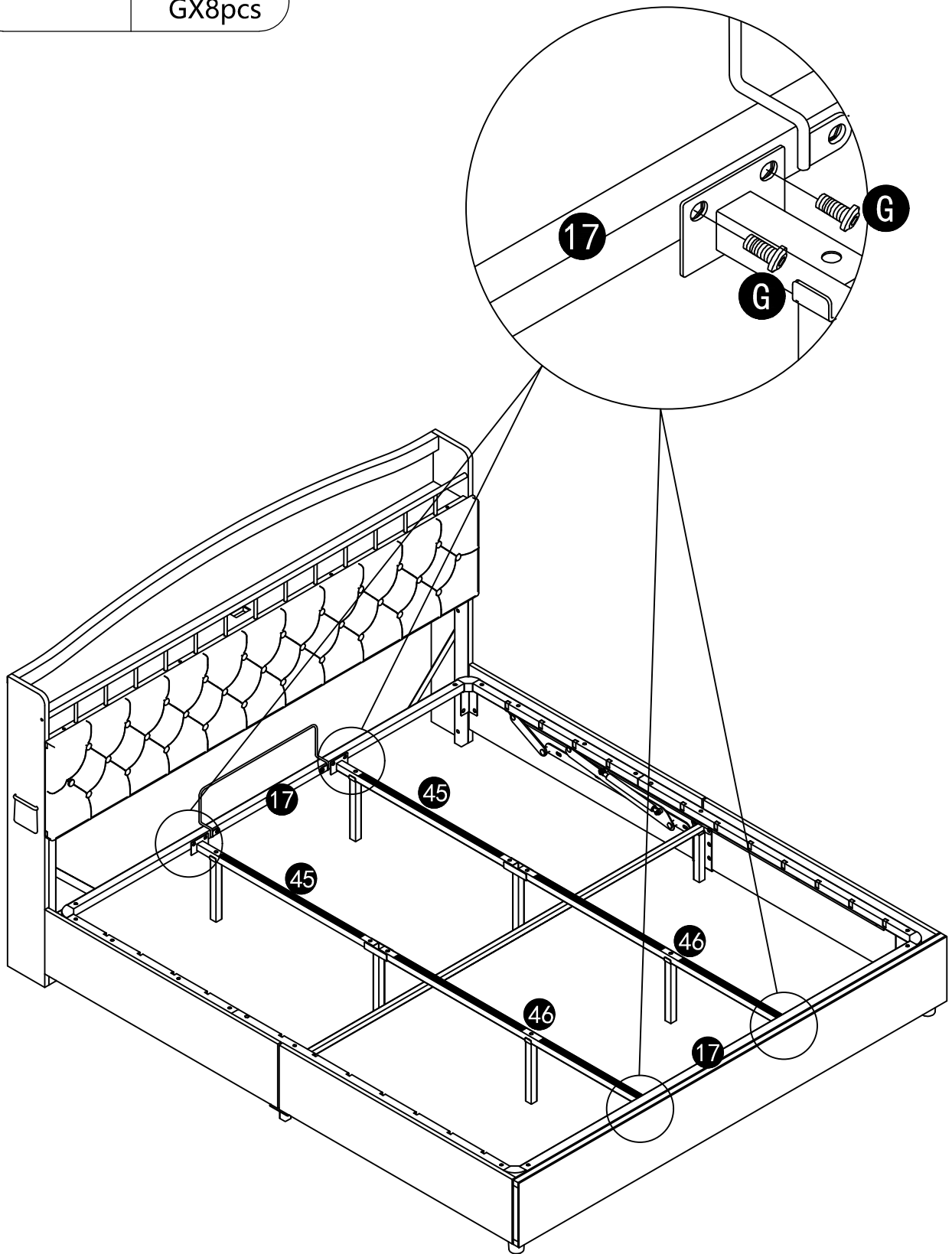

29

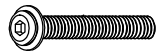

M8X48
JX2pcs



M8X20
GX2pcs

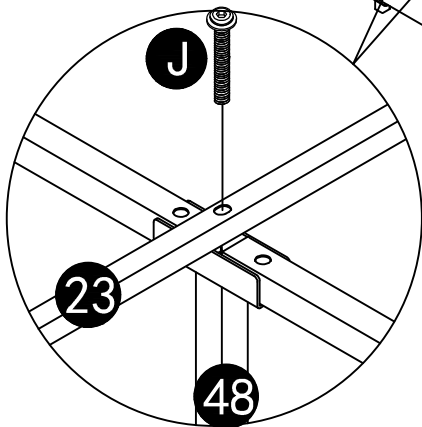
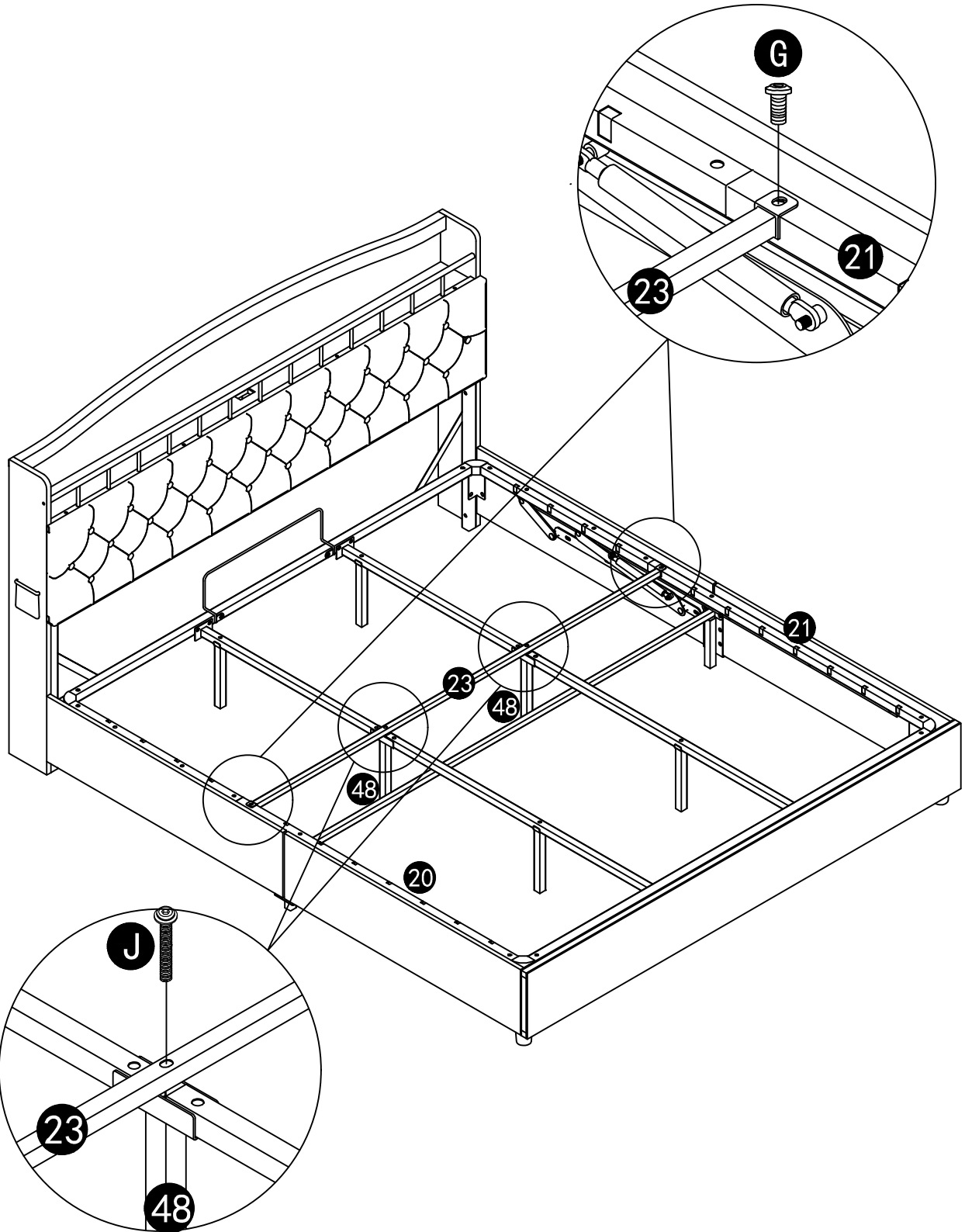

30

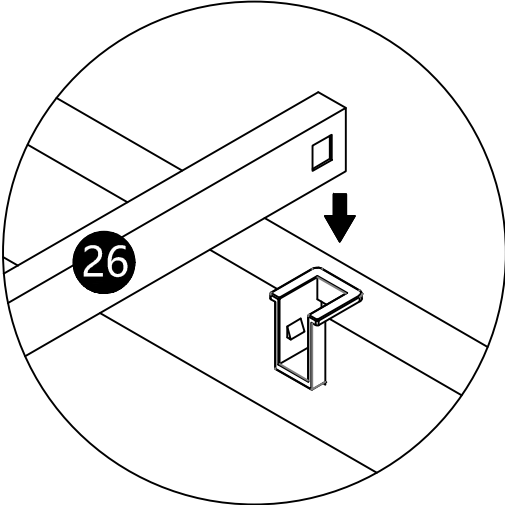
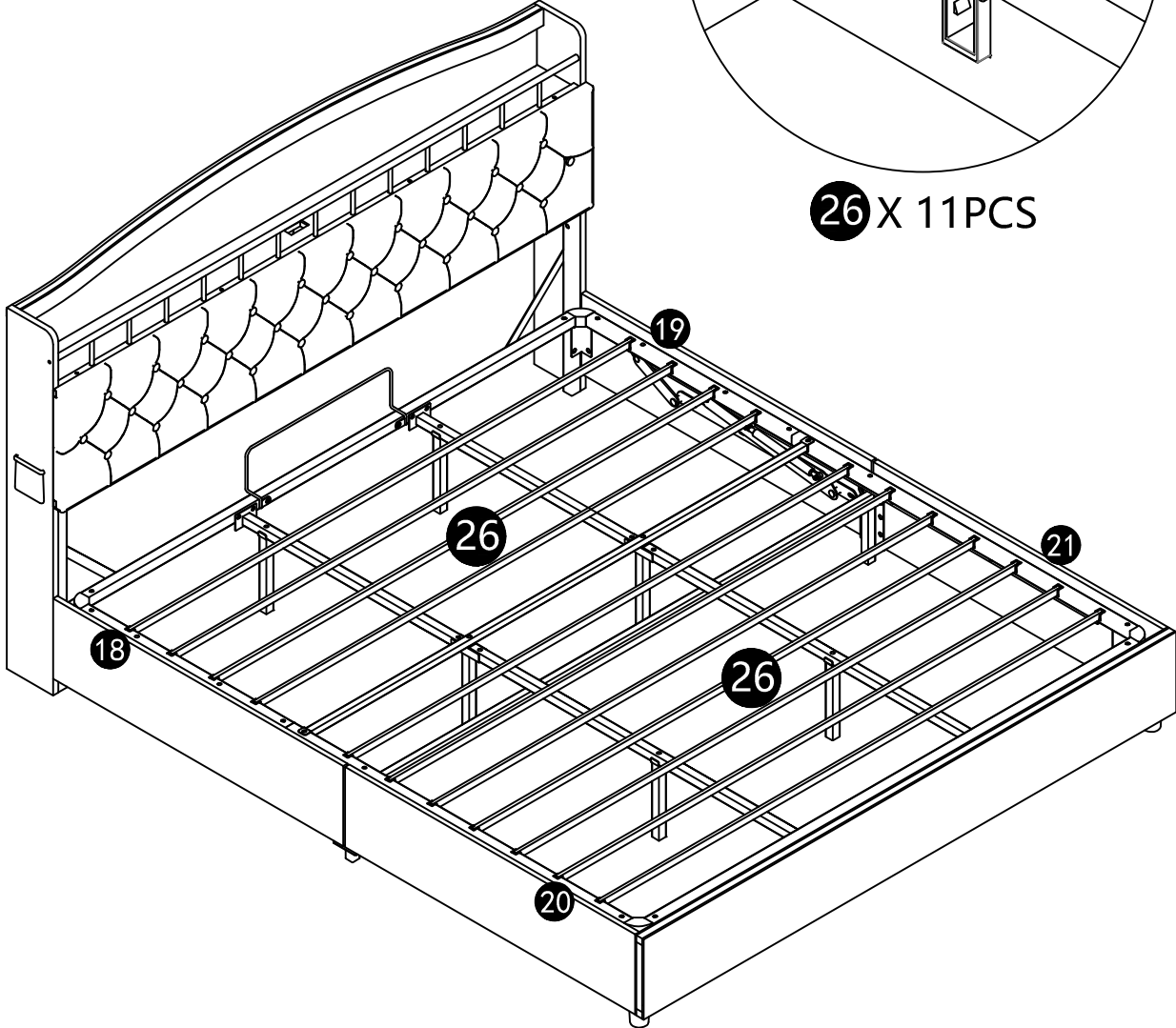

26 X 11PCS

31

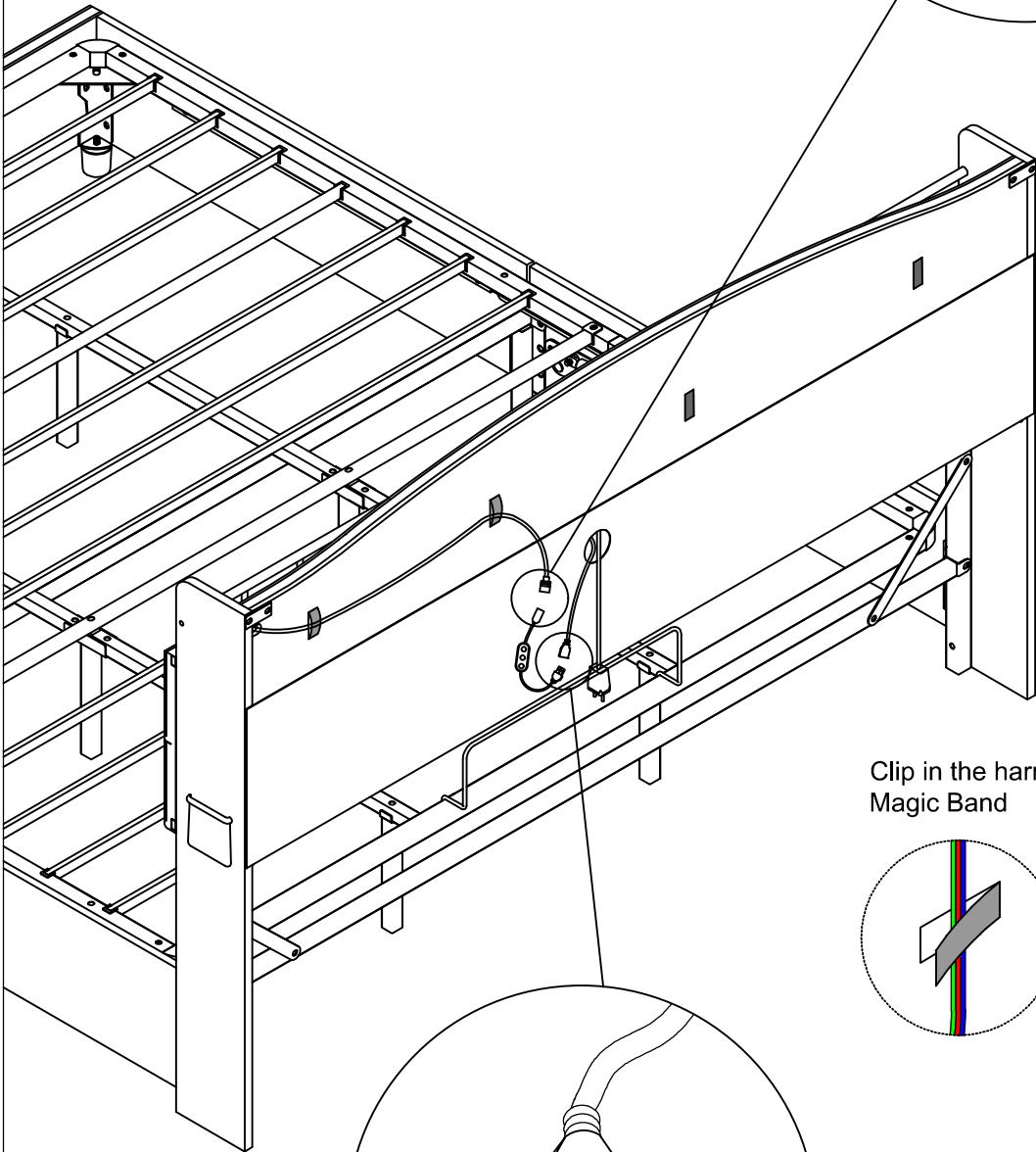
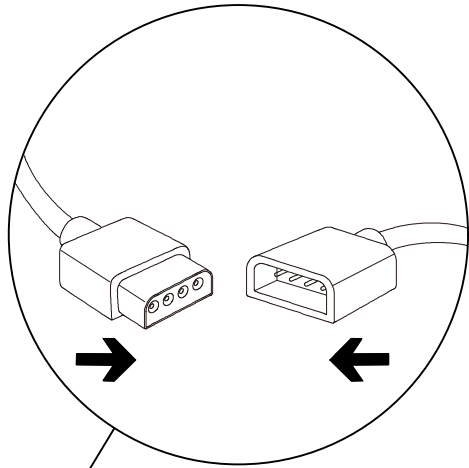
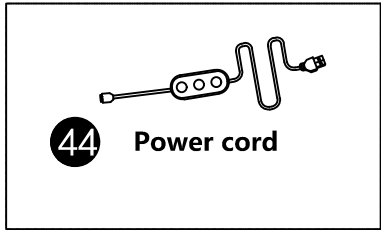

Clip in the harness
Magic Band

Stick to

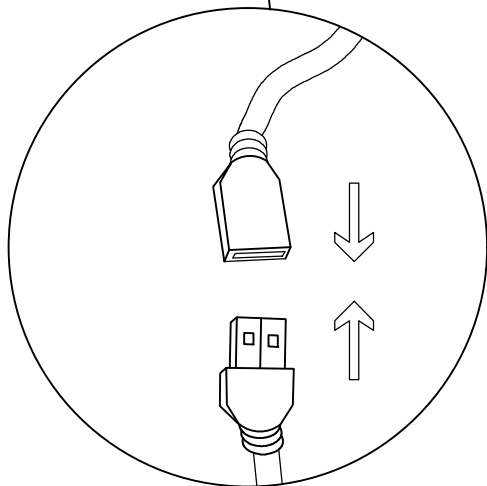
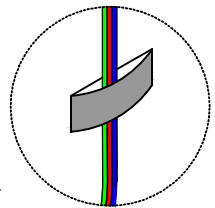
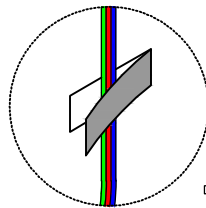

32

