

Este es el producto que ha comprado!
This is the product you have purchased!
Esse é o produto que você adquiriu!
Voici le produit que vous avez acheté!

Ref. 1138

Espejo opcional. Fijación con cinta de doble face.

Optional mirror. Fixing with double-face.
Espelho opcional. Fixação com fita dupla face.
Miroir en option. Fixation avec ruban adhésif double face.

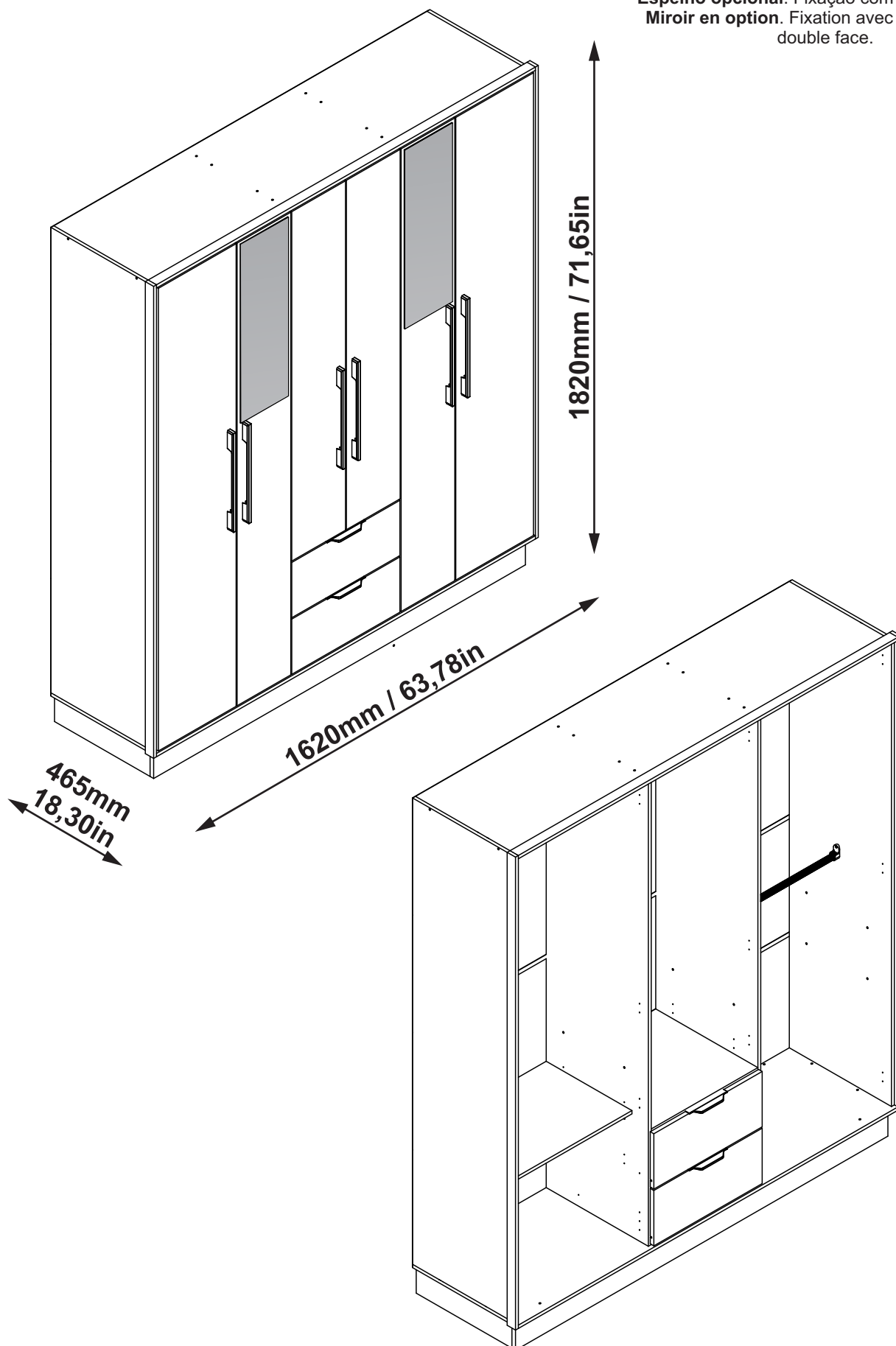

RECOMENDACIONES PARA EL USO Y CUIDADO DEL PRODUCTO
RECOMMENDATIONS FOR THE USE AND CARE OF THE PRODUCT
RECOMENDAÇÕES DE USO E CUIDADOS COM O PRODUTO
RECOMMANDATIONS POUR L'UTILISATION ET L'ENTRETIEN DU PRODUIT



ES: Lea cuidadosamente el manual y siga en el orden indicado las instrucciones de ensamble.
EN: Read the manual carefully and follow the assembly instructions in the order listed.
PT: Leia o manual com atenção e siga as instruções de montagem na ordem listada.
FR: Lisez attentivement le manuel et suivez les instructions de montage dans l'ordre indiqué.



ES: No pinte ni use elementos abrasivos para limpiar el mueble.
EN: Do not paint or use abrasive items to clean the furniture.
PT: Não pinte ou use itens abrasivos para limpar o móvel.
FR: Ne pas peindre ni utiliser d'objets abrasifs pour nettoyer l'armoire.



ES: No exponga el mueble al calor ni a la humedad.
EN: Do not expose the furniture to heat or humidity.
PT: Não exponha a mobília ao calor ou umidade.
FR: N'exposez pas le meuble à la chaleur ou à l'humidité.



ES: - No arraste el mueble, esto puede causar daños en las piezas.
 - Para desplazar el mueble asegúrese de moverlo cuando este vacío sin objetos.
 - Siempre solicite ayuda a otra persona para moverlo.
EN: - Do not drag the furniture, this can cause damage to the pieces.
 - To move the furniture be sure to move it when it is empty without objects.
 - Always ask someone else to help you move it.
PT: - Não arraste o móvel, pois isso pode causar danos às peças.
 - Para mover o móvel certifique-se de movê-lo quando estiver vazio e sem objetos.
 - Sempre peça a outra pessoa para ajudá-lo a movê-lo.
FR: - Ne traînez pas le meuble, cela peut endommager les pièces.
 - Pour déplacer le meuble veillez à le déplacer lorsqu'il est vide sans objets.
 - Demandez toujours à quelqu'un d'autre de vous aider à le déplacer.

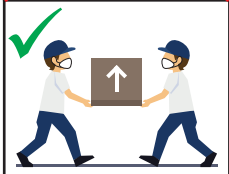

ES: - Limpia regularmente la madera con un paño de microfibra para que no se acumule el polvo y así evitar que el mueble pierda su brillo.
EN: Regularly clean the wood with a microfiber cloth so that dust does not accumulate and thus prevent the furniture from losing its shine.
PT: Limpe regularmente a madeira com um pano de microfibra para que o pó não se acumule e evite que o móvel perca o brilho.
FR: Nettoyez régulièrement le bois avec un chiffon microfibre afin que la poussière ne s'accumule pas et ainsi éviter que le meuble ne perde de son éclat.



ES: - No utilice papel periódico para brillar vidrios y/o espejos, esto los puede rayar. Es recomendable utilizar paños que no dejen pelusa.
EN: Do not use newspaper to shine glass and / or mirrors, this can scratch them. It is recommended to use lint-free cloths.
PT: Não use jornal para lustrear vidros e / ou espelhos, pois podem riscá-los. É aconselhável usar panos sem fiapos.
FR: N'utilisez pas de papier journal pour faire briller le verre et/ou les miroirs, cela peut les rayar. Il est conseillé d'utiliser des chiffons non pelucheux.



ES: Evita que el agua entre en contacto con las partes de metal, ya que puede provocar manchas y óxido.
EN: Avoid getting water on metal parts as it can cause stains and rust.
PT: Evite molhar as peças de metal, pois pode causar manchas e ferrugem.
FR: Évitez de mettre de l'eau sur les pièces métalliques car cela peut causer des taches et de la rouille.



ES: Ubica tus productos en una superficie lisa y plana. Utilice una protección entre el mueble y el piso.
EN: Place your products on a smooth, flat surface. Use a protection between the furniture and the floor.
PT: Coloque seus produtos em uma superfície lisa e plana. Use uma proteção entre a mobília e o chão.
FR: Placez vos produits sur une surface lisse et plane. Utilisez une protection entre le meuble et le sol.



ES: Ubica tus productos en una superficie lisa y plana. Utilice una protección entre el mueble y el piso.
EN: Place your products on a smooth, flat surface. Use a protection between the furniture and the floor.
PT: Coloque seus produtos em uma superfície lisa e plana. Use uma proteção entre a mobília e o chão.
FR: Placez vos produits sur une surface lisse et plane. Utilisez une protection entre le meuble et le sol.

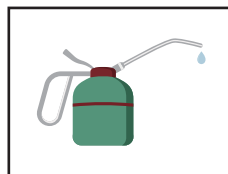

ES: Se recomienda lubricar cada 3 meses rieles, correderas, bisagras y rodachinas.
EN: It is recommended to lubricate the rails, runners, hinges and castors every 3 months.
PT: Recomenda-se a lubrificação de trilhos, corredeiras, dobradiças e rodízios a cada 3 meses.
FR: Il est recommandé de lubrifier les rails, glissières, charnières et roulettes tous les 3 mois.

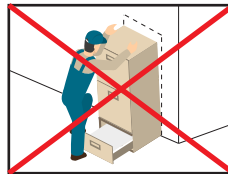

ES: No utilizar las gavetas como escaleras ni permitir que los niños se cuelguen de las puertas.
EN: Do not use drawers as ladders or allow children to hang from doors.
PT: Não use gavetas como escadas, nem permita que crianças se pendurem nas portas.
FR: N'utilisez pas les tiroirs comme échelles et ne laissez pas les enfants se suspendre aux portes.



ES: Evita que el trapeador o elementos similares entren en contacto con tus muebles ya que esto puede deteriorarlos.
EN: Avoid that the mop or similar elements come into contact with your furniture as this can deteriorate them.
PT: Evite que a esfregona ou elementos semelhantes entrem em contacto com os seus móveis, pois pode deteriorá-los.
FR: Évitez que la serpillière ou des éléments similaires entrent en contact avec vos meubles car cela peut les détériorer.



ES: Mantén alejado objetos puntiagudos como tijeras, llaves o cuchillos. Éstos pueden causar cortes y/o rayones.
EN: Keep sharp objects like scissors, keys, or knives away. These can cause cuts and / or scratches.
PT: Mantenha objetos pontiagudos como tesouras, chaves ou facas longe. Isso pode causar cortes e / ou arranhões.
FR: Gardez les objets pointus comme des ciseaux, des clés ou des couteaux à distance. Ceux-ci peuvent provoquer des coupures et/ou des rayures.

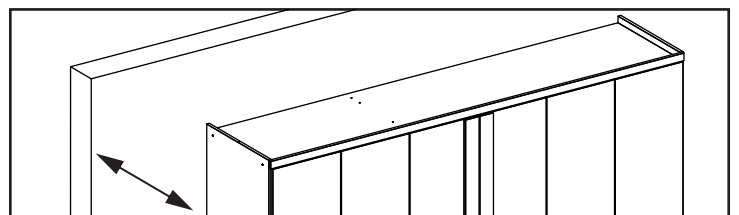

ES: Se recomienda separar de la pared tus productos para que estos puedan tener una circulación de aire natural.
EN: It is recommended to separate your products from the wall so that they can have a natural air circulation.
PT: Recomenda-se separar seus produtos da parede para que tenham uma circulação natural de ar.
FR: Il est recommandé de séparer vos produits du mur afin qu'ils puissent avoir une circulation d'air naturelle.

Consejos de Conservación y Pesos soportados

Conservation Tips and Supported Weights

Dicas de Conservação e Pesos Suportados

Conseils d'entretien et Poids soutenus

ES: 1. No debe utilizarse en la limpieza, abrasivos como lana de acero, alcohol, limón, o productos corrosivos que puedan rayar o quitar la película en los muebles.

2. Cuando la limpieza de muebles en general, napa y formica, deben utilizarse un paño ligeramente humedecido y jabón suave.

3. Para mover el mueble, es importante que este se eleve desde el suelo, debido a que el arrastre puede causar daño estructural.

4. No deje el mueble en exposición a la intemperie.

EN: 1. Do not use abrasive products to clean such as steel wool, alcohol, vinegar, lemon, scouring powder, or corrosive products which can scratch or peel off the protective film of the furniture.

2. The best way to clean your furniture is to use a slightly moistened cloth with a mild soap.

3. To move the furniture assembled, it is important that it is lifted off the ground, because the drag it can cause structural damage.

4. Do not leave your furniture in weather exposure.

PT: 1. Não utilizar na limpeza produtos abrasivos tais como: palha de aço, álcool, vinagre, limão, saponáceo ou produtos corrosivos que possam riscar ou descolar a película protetora dos móveis.

2. Na limpeza de móveis em geral, napas e fórmicas, deve ser utilizado um pano levemente umedecido e sabão neutro.

3. Para a movimentação do móvel, é importante que este seja levantado do chão, pois ao arrastá-lo pode causar avarias estruturais.

4. Não deixe o móvel em exposição a intempéries.

FR: 1. Ne pas utiliser de produits abrasifs dans le nettoyage, tels que: laine d'acier, alcool, vinaigre, citron, poudre à récurer ou autres produits corrosifs pouvant rayer ou faire décoller la pellicule protectrice des meubles.

2. Pour le nettoyage du meuble, il est recommandé d'utiliser un chiffon humide et du savon neutre.

3. Pour déplacer le meuble, il est important de le soulever du sol car le tirer pourrait causer des dommages dans sa structure.

4. Ne pas exposer le meuble aux intempéries.

ES: Por favor, preste atención a los pesos máximos admitidos por cada compartimento del producto. Tenga cuidado de no exceder estos pesos, con el fin de garantizar la calidad y durabilidad del producto. Es importante recordar que los pesos muestran en caso de ser DISTRIBUIDA en toda el área de la plataforma.

EN: Please pay attention to the maximum weights supported by each compartment product. Be careful not to exceed these weights, in order to ensure the quality and durability of the product. It is important to remember also that the weights shown should be DISTRIBUTED throughout the area of the shelf.

PT: Por favor, preste atenção aos pesos máximos suportados por cada compartimento do produto. Cuide para não exceder esses pesos, afim de garantir a qualidade e a durabilidade do mesmo. É importante lembrar também que, os pesos mostrados devem ser DISTRIBUÍDOS ao longo de toda a área da peça.

FR: Veuillez faire attention aux poids maximums supportés par chaque produit du compartiment. Veuillez à ne pas dépasser ces poids, afin de garantir la qualité et la durabilité du produit. Il est également important de se rappeler que les poids indiqués doivent être RÉPARTIS sur toute la surface du rayon.

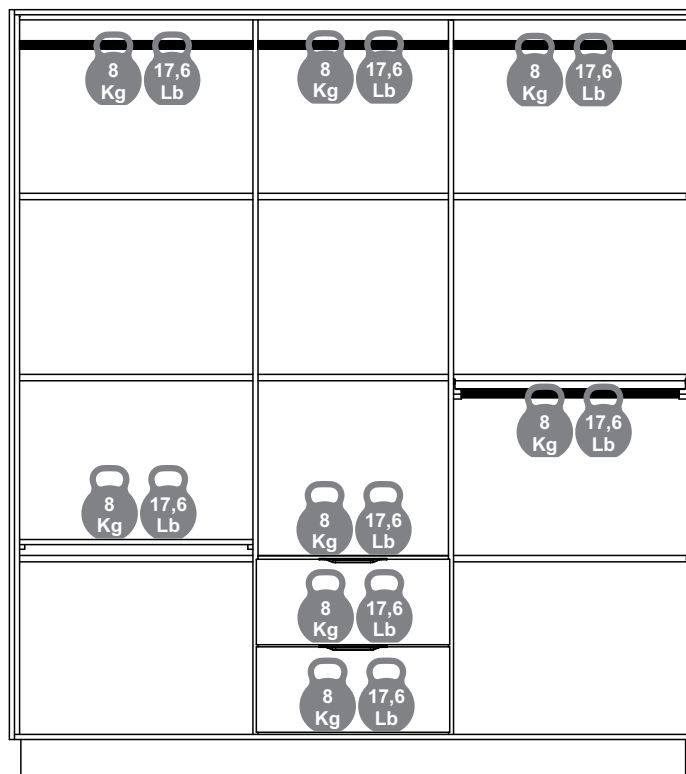



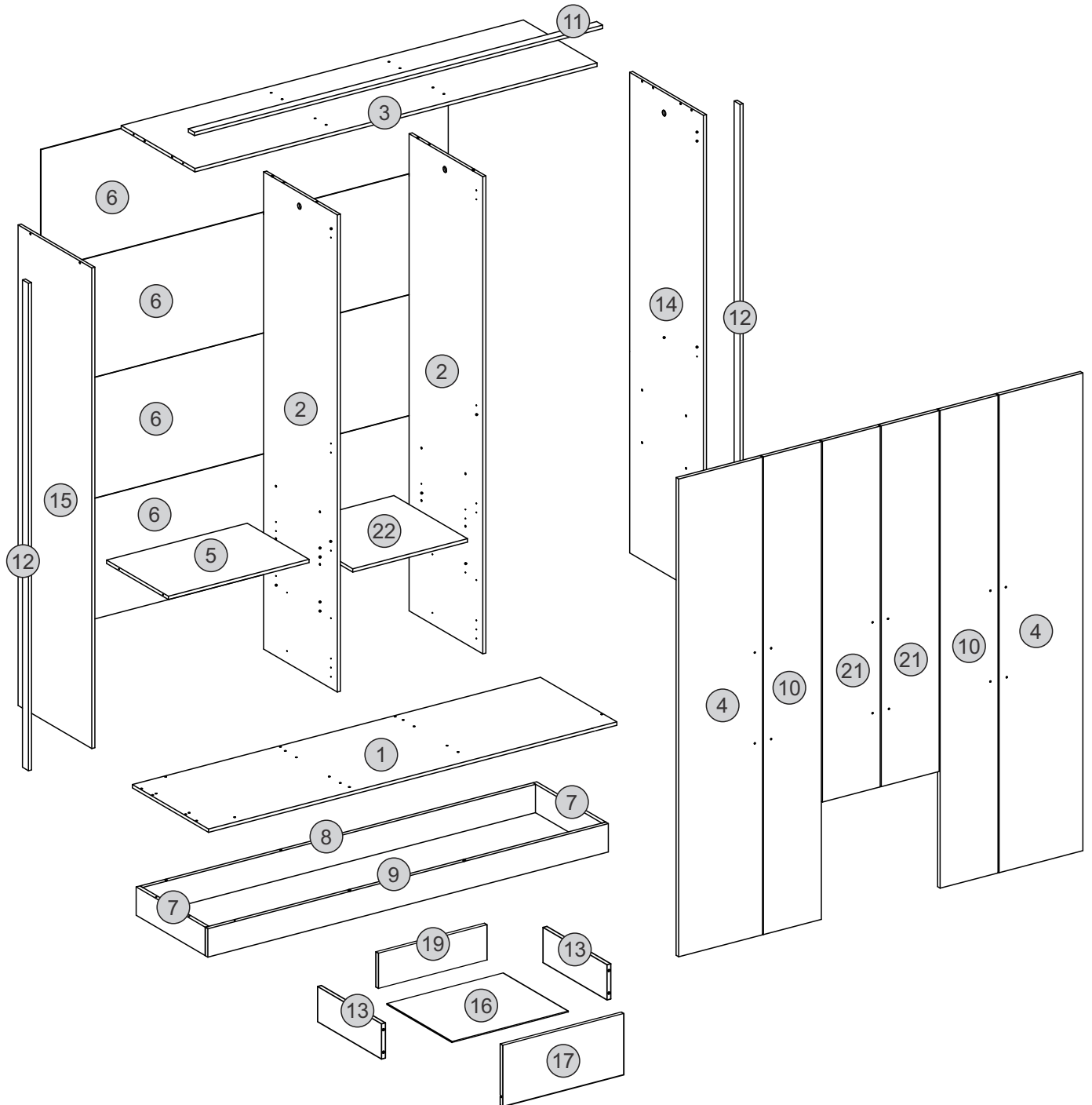



Conocer mejor las piezas de su producto
Getting to know your product parts better
Conhecendo melhor as peças do seu produto
Mieux connaître les pièces de votre produit

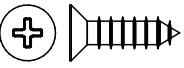
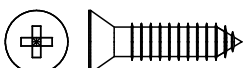
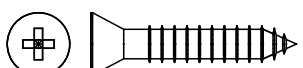

Conocer mejor las piezas de su producto / Getting to know your product parts better
Conhecendo melhor as peças do seu produto / Mieux connaître les pièces de votre produit

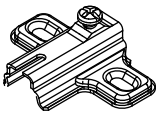
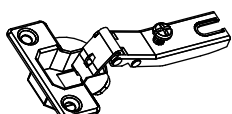
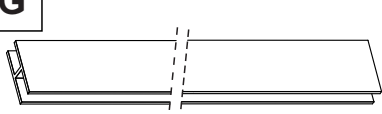
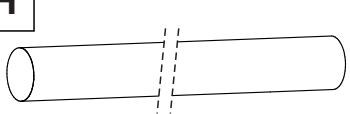
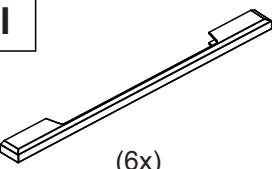
#	Ct. Qt.	Español	English	Português	Français	mm in
1	1	Base	Base	Base	Fond	1594 x 444 x 12 mm 62,76 x 17,48 x 0,47 in
2	2	División	Division	Divisão	Séparateur	1681 x 429 x 12 mm 66,18 x 16,89 x 0,47 in
3	1	Tapa	Top	Tampo	Dessus de Tiroir	1570 x 429 x 12 mm 61,81 x 16,89 x 0,47 in
4	2	Puerta Mayor	Large Door	Porta Maior	Grand Porte	1683 x 327 x 15 mm 66,26 x 12,87 x 0,59 in
5	1	Repisa Mayor	Large Shelf	Prateleira Maior	Grand Etàgere	549 x 360 x 12 mm 21,61 x 14,17 x 0,47 in
6	4	Costado	Back Panel	Costa	Pièce Arrière	1590 x 425 x 3 mm 62,60 x 16,73 x 0,11 in
7	2	Zócalo Lateral	Side Baseboard	Rodapé Lateral	Socle Latéral	402 x 100 x 15 mm 15,83 x 3,94 x 0,59 in
8	1	Zócalo de atrás	Back Baseboard	Rodapé Traseiro	Socle Arrière	1534 x 100 x 15 mm 60,39 x 3,94 x 0,59 in
9	1	Zócalo Delantero	Front Baseboard	Rodapé Dianteiro	Socle Avanti	1564 x 100 x 15 mm 61,57 x 3,94 x 0,59 in
10	2	Puerta Menor	Small Door	Porta Menor	Petit Porte	1683 x 226 x 15 mm 66,26 x 8,90 x 0,59 in
11	1	Marco Superior	Upper Frame	Moldura Superior	Cadre Supérieur	1594 x 35 x 12 mm 62,76 x 1,38 x 0,47 in
12	2	Marco Lateral	Side Frame	Moldura Lateral	Cadre Latéral	1717 x 35 x 12 mm 67,60 x 1,38 x 0,47 in
13	4	Lateral Cajón	Drawer Side	Lateral de Gaveta	Coté Droit et Gauche Tiroir	300 x 100 x 12 mm 11,81 x 3,94 x 0,47 in
14	1	Lateral Derecha	Right Side	Lateral Direita	Coté Droit	1693 x 429 x 12 mm 66,65 x 16,89 x 0,47 in
15	1	Lateral Izquierda	Left Side	Lateral Esquerda	Coté Gauche	1693 x 429 x 12 mm 66,65 x 16,89 x 0,47 in
16	2	Fondo Cajón	Drawer Bottom	Fundo de Gaveta	Fond Tiroir	423 x 305 x 3 mm 16,69 x 12,01 x 0,11 in
17	2	Frente Cajón	Drawer Front	Frente de Gaveta	Façade Tiroir	455 x 201 x 15 mm 17,91 x 7,91 x 0,59 in
19	2	Trasero Cajón	Drawer Back	Costa de Gaveta	Pièce Arrière Tiroir	399 x 100 x 12 mm 15,75 x 3,94 x 0,47 in
21	2	Puerta Central	Central Door	Porta Central	Porte Centrale	1271 x 226 x 15 mm 50,04 x 8,90 x 0,59 in
22	1	Tapa Cajones	Top Drawers	Tampo Gavetas	Tiroirs du Haut	448 x 429 x 12 mm 17,64 x 16,89 x 0,47 in

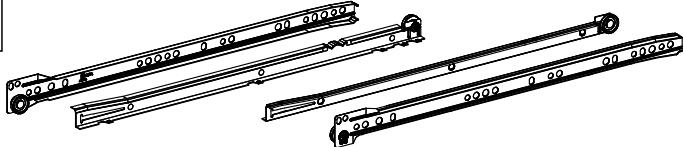
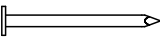
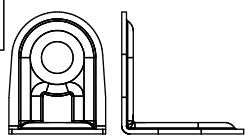
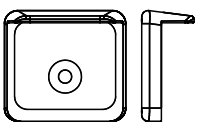
Y estos son sus Accesorios
And these are your Accessories
E estes são os seus Acessórios
ET voici vos Accessoires

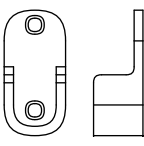
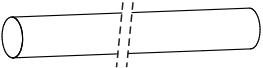
A  Ø3,5x12mm/0,16x0,45in (108x)	B  Ø4x20mm/0,16x0,79in (19x)	C  Ø4x25mm/0,16x0,98in (12x)	D  Ø4x40mm/0,16x1,57in (32x)
E  (16x)	F  (16x)	G  (3x)	H  (1x)
I  (6x)	J  Ø6x30mm/0,24x1,18in (24x)	K  (2x)	
L  (122x)	M  (8x)	N  (8x)	O  (4x)
Q  (2x)	R  (1x)		

HERRAMIENTAS NECESARIAS / TOOLS REQUIRED / FERRAMENTAS NECESSÁRIAS / OUTILS NÉCESSAIRES

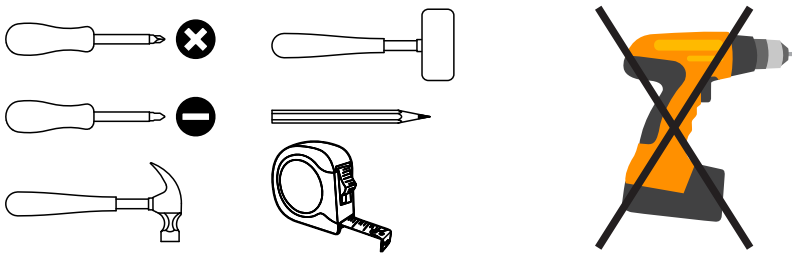

ES: NO UTILICE UN DESTORNILLADOR ELÉCTRICO O A BATERÍADO
EN: NOT USE A BATTERY OR ELECTRIC SCREWDRIVER
PT: NÃO UTILIZE PARAFUSADEIRA ELÉTRICA OU À BATERIA
FR: NE PAS UTILISER DE TOURNEVIS ÉLECTRIQUE OU À BATTERIE

Y si lo necesitas, mide en la regla al lado
 And if you need to, measure on the ruler beside
 E se precisar, meça na régua ao lado
 ET si vous en avez besoin, mesurez sur la règle à côté



**NÚMERO DE PERSONAS Y
ÁREA DE ARMADO**

**NUMBER OF PEOPLE AND
ASSEMBLY AREA**

**NÚMERO DE PESSOAS E
ÁREA DE MONTAGEM**

**NOMBRE DE PERSONNES
ET ZONE DE
RASSEMBLEMENT**

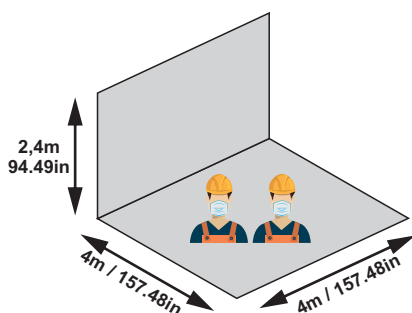

**TIEMPO ESTIMADO DE
ARMADO**

**ESTIMATED ASSEMBLY
TIME**

**TEMPO DE MONTAGEM
ESTIMADO**

**TEMPS DE MONTAGE
ESTIMÉ**



90 min

Antes de comenzar el montaje, asegure los espejos a la puerta!

La acción del pegamento es inmediata, pero dejar la puerta en posición horizontal por un tiempo ayuda con la fijación permanente.

Before starting the assembly, fix the mirrors to the door!

The action of the glue is immediate, but leaving the door in a horizontal position for a while helps with permanent fixing.

Antes de iniciar a montagem, fixe os espelhos na porta!

A ação da cola é imediata, mas deixar a porta por algum tempo em posição horizontal ajuda na fixação permanente.

Avant de commencer le montage, fixez les miroirs à la porte!

L'action de la colle est immédiate, mais laisser la porte en position horizontale pendant un certain temps aide à la fixation permanente.

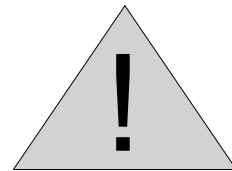

SOLO PARA VERSIÓN CON ESPEJO
FOR VERSION WITH MIRROR ONLY
APENAS PARA VERSÃO COM ESPELHOS
POUR VERSION AVEC MIROIRS UNIQUEMENT

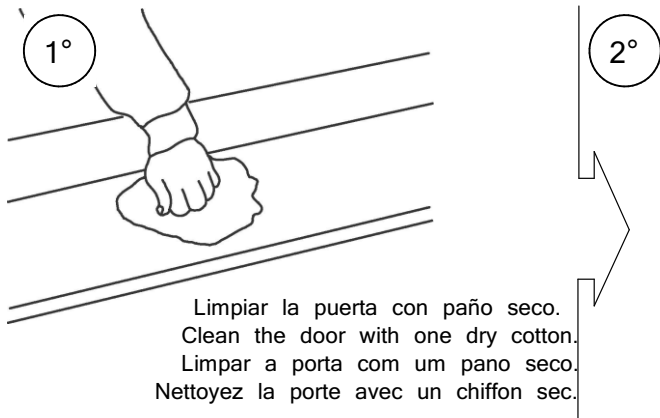

1°
Limpia la puerta con paño seco.
Clean the door with one dry cotton.
Limpar a porta com um pano seco.
Nettoyez la porte avec un chiffon sec.

2°
Marca la puerta para arreglar el espejo.
Mark the door to fix the mirror.
Marcar a porta para colocação do espelho.
Marquez la porte pour le placement du miroir.

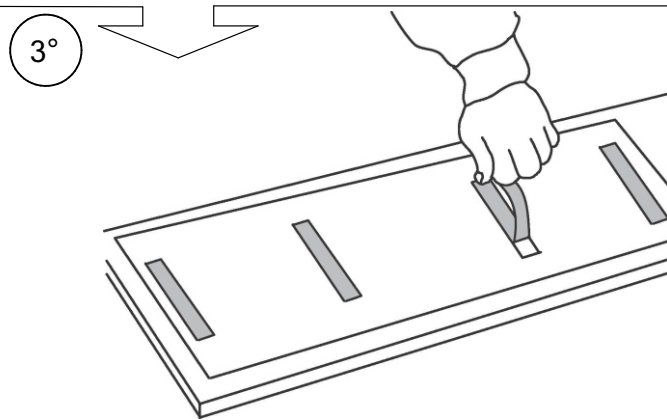
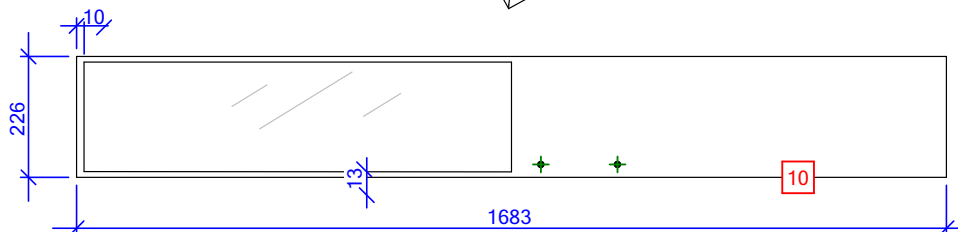
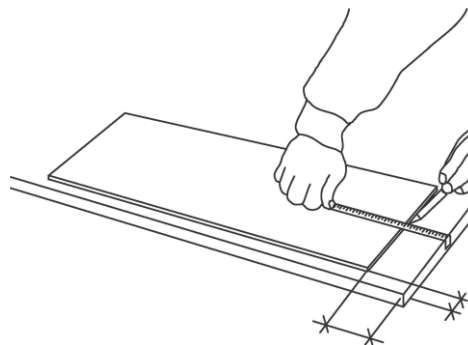

3°
Sacar con cuidado la protección de la cinta dupla face.
Take off carefully the protection of double band of the face.
Tirar com cuidado a proteção da fita dupla face.
Retirez délicatement la protection du ruban adhésif double face.

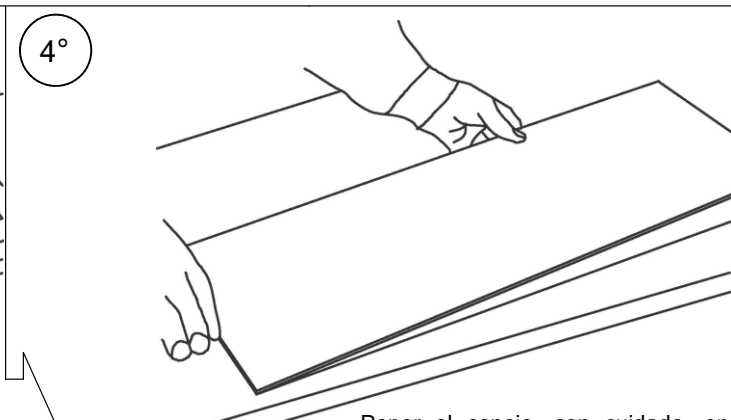

4°
Poner el espejo, con cuidado, en la posición marcada.
Fix the mirror, carefully in the marked place.
Colocar o espelho, cuidadosamente, no lugar marcado.
Placez soigneusement le miroir à l'endroit marqué.

Deje las puertas en posición horizontal, hasta el final del montaje!

La acción del pegamento es inmediata, pero dejar la puerta en posición horizontal por un tiempo ayuda con la fijación permanente.

Leave the doors in a horizontal position, until the end of the assembly!

The action of the glue is immediate, but leaving the door in a horizontal position for a while helps with permanent fixing.

Deixe as portas em posição horizontal, até o fim da montagem!

A ação da cola é imediata, mas deixar a porta por algum tempo em posição horizontal ajuda na fixação permanente.

Laisser les portes en position horizontale jusqu'à la fin du montage!

L'action de la colle est immédiate, mais laisser la porte en position horizontale pendant un certain temps aide à la fixation permanente.

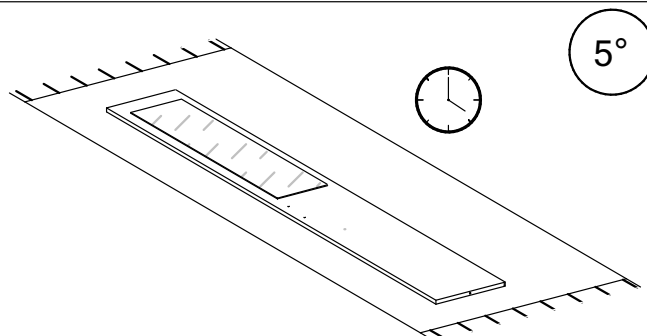

5°

PIEZAS NECESARIAS
PARTS REQUIRED
PEÇAS NECESSÁRIAS
PIÉCES NÉCESSAIRES

2	x2	3	x1
14	x1	15	x1

ACCESORIOS NECESARIOS
HARDWARE REQUIRED
ACESSÓRIOS NECESSÁRIOS
ACCESSOIRES NÉCESSAIRES

A		10x	K		2x
B		4x	O		4x
J		16x			

HERRAMIENTAS NECESARIAS
TOOLS REQUIRED
FERRAMENTAS NECESSÁRIAS
OUTILS NÉCESSAIRES

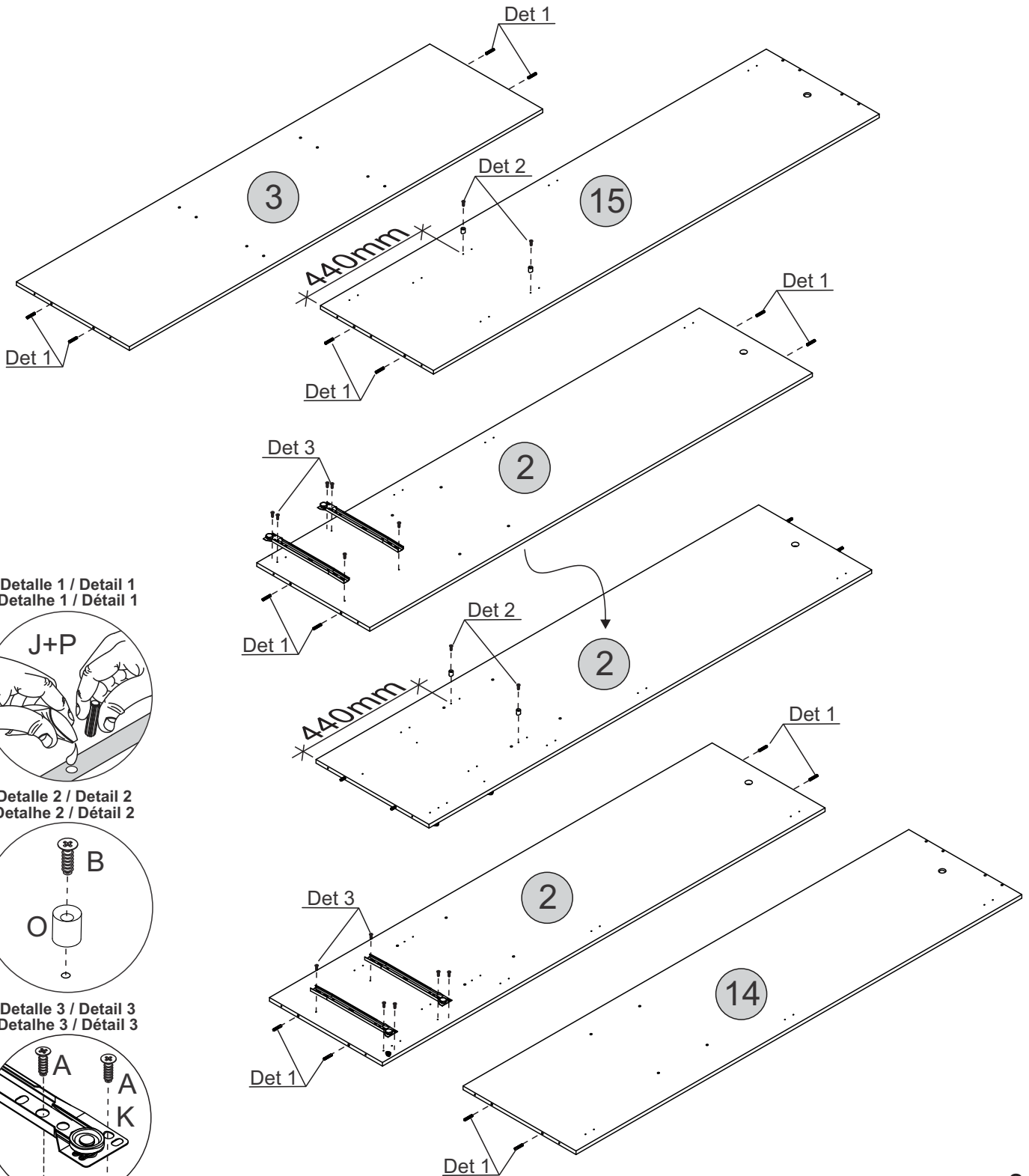
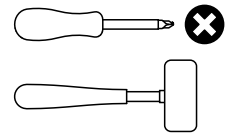

Detalle 1 / Detail 1
Detalhe 1 / Détail 1



Detalle 2 / Detail 2
Detalhe 2 / Détail 2

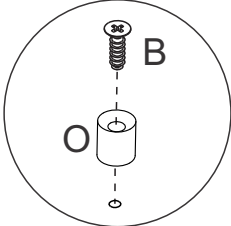

Detalle 3 / Detail 3
Detalhe 3 / Détail 3

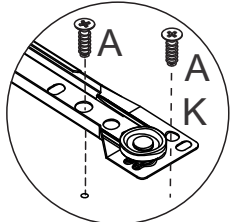

2

PIEZAS NECESARIAS
PARTS REQUIRED
PEÇAS NECESSÁRIAS
PIÈCES NÉCESSAIRES

2 x2 3 x1 22 x1

ACCESORIOS NECESARIOS
HARDWARE REQUIRED
ACESSÓRIOS NECESSÁRIOS
ACCESSOIRES NÉCESSAIRES

D  8x
Ø4x40mm/0,16x1,57in

HERRAMIENTAS NECESARIAS
TOOLS REQUIRED
FERRAMENTAS NECESSÁRIAS
OUTILS NÉCESSAIRES

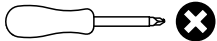

Detalle 4 / Detail 4
Detalhe 4 / Détail 4

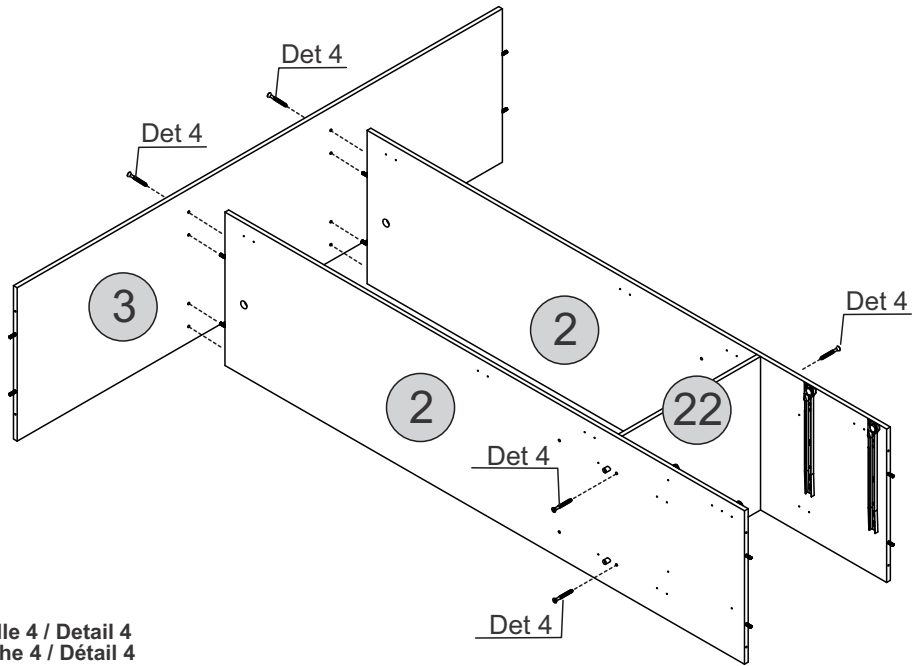
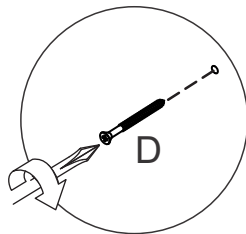

3

PIEZAS NECESARIAS
PARTS REQUIRED
PEÇAS NECESSÁRIAS
PIÈCES NÉCESSAIRES

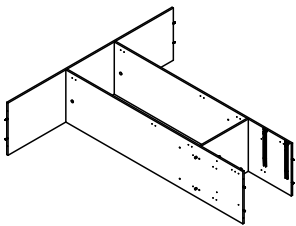

14 x1

ACCESORIOS NECESARIOS
HARDWARE REQUIRED
ACESSÓRIOS NECESSÁRIOS
ACCESSOIRES NÉCESSAIRES

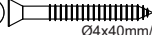
D  2x
Ø4x40mm/0,16x1,57in

HERRAMIENTAS NECESARIAS
TOOLS REQUIRED
FERRAMENTAS NECESSÁRIAS
OUTILS NÉCESSAIRES

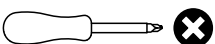

Detalle 4 / Detail 4
Detalhe 4 / Détail 4

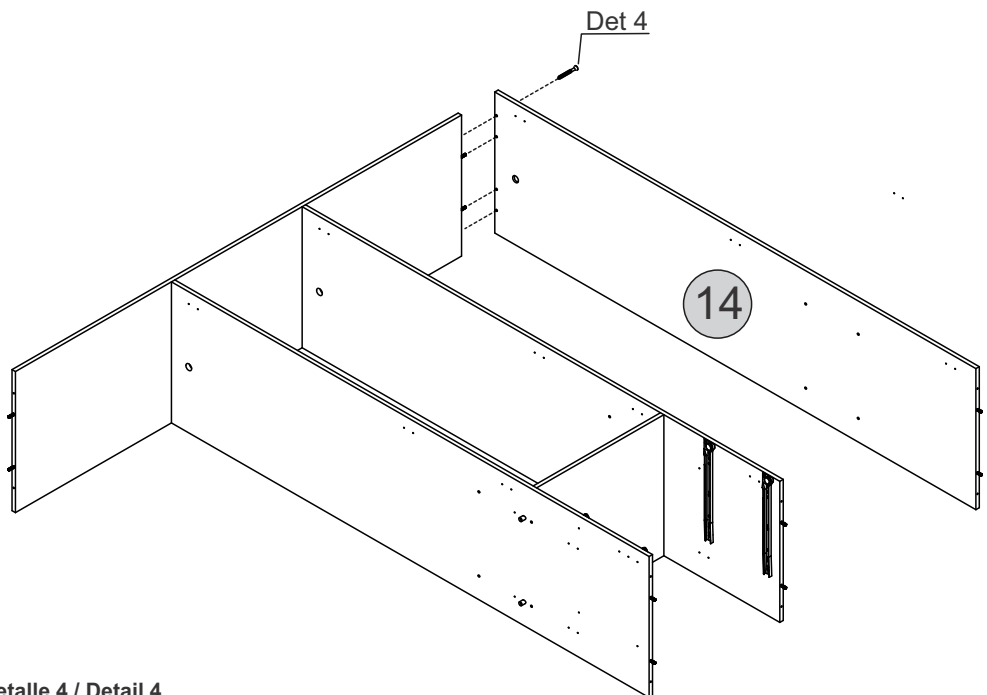
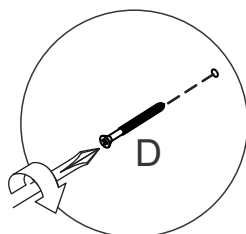

4

PIEZAS NECESARIAS
PARTS REQUIRED
PEÇAS NECESSÁRIAS
PIÈCES NÉCESSAIRES

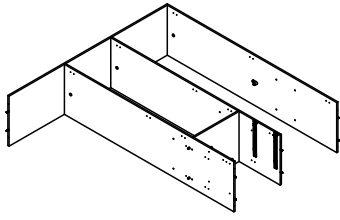

ACCESORIOS NECESARIOS
HARDWARE REQUIRED
ACESSÓRIOS NECESSÁRIOS
ACCESSOIRES NÉCESSAIRES

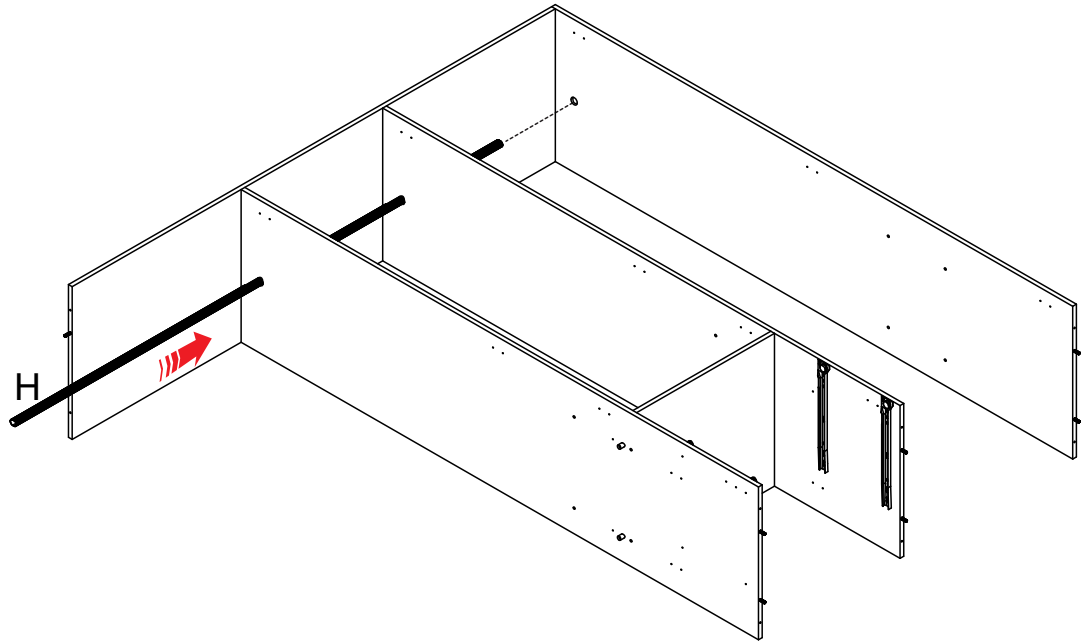

5

PIEZAS NECESARIAS
PARTS REQUIRED
PEÇAS NECESSÁRIAS
PIÈCES NÉCESSAIRES

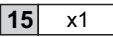
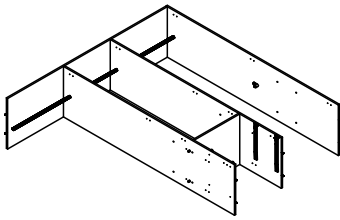

ACCESORIOS NECESARIOS
HARDWARE REQUIRED
ACESSÓRIOS NECESSÁRIOS
ACCESSOIRES NÉCESSAIRES



HERRAMIENTAS NECESARIAS
TOOLS REQUIRED
FERRAMENTAS NECESSÁRIAS
OUTILS NÉCESSAIRES

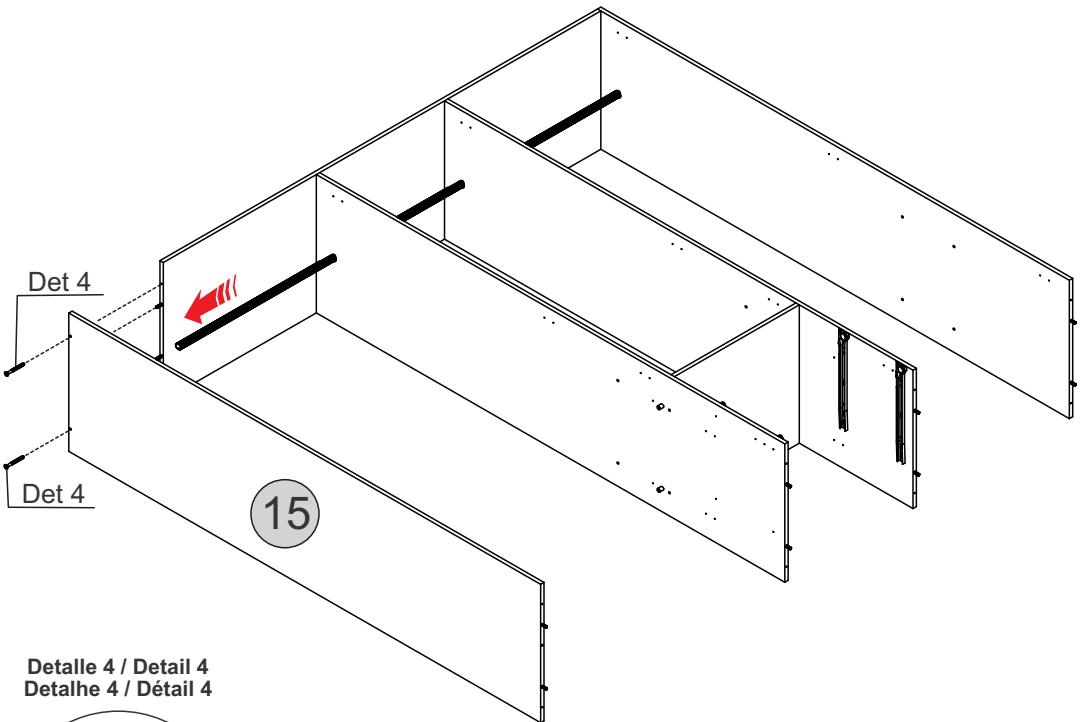
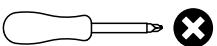

Detalle 4 / Detail 4
Detalhe 4 / Détail 4

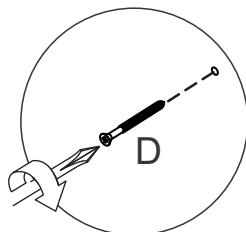

6

PIEZAS NECESARIAS
PARTS REQUIRED
PEÇAS NECESSÁRIAS
PIÈCES NÉCESSAIRES

7	x2	8	x1	9	x1
---	----	---	----	---	----

ACCESORIOS NECESARIOS
HARDWARE REQUIRED
ACESSÓRIOS NECESSÁRIOS
ACCESSOIRES NÉCESSAIRES

A		8x
Ø3,5x12mm/0,14x0,45in		

M		4x
---	--	----

HERRAMIENTAS NECESARIAS
TOOLS REQUIRED
FERRAMENTAS NECESSÁRIAS
OUTILS NÉCESSAIRES

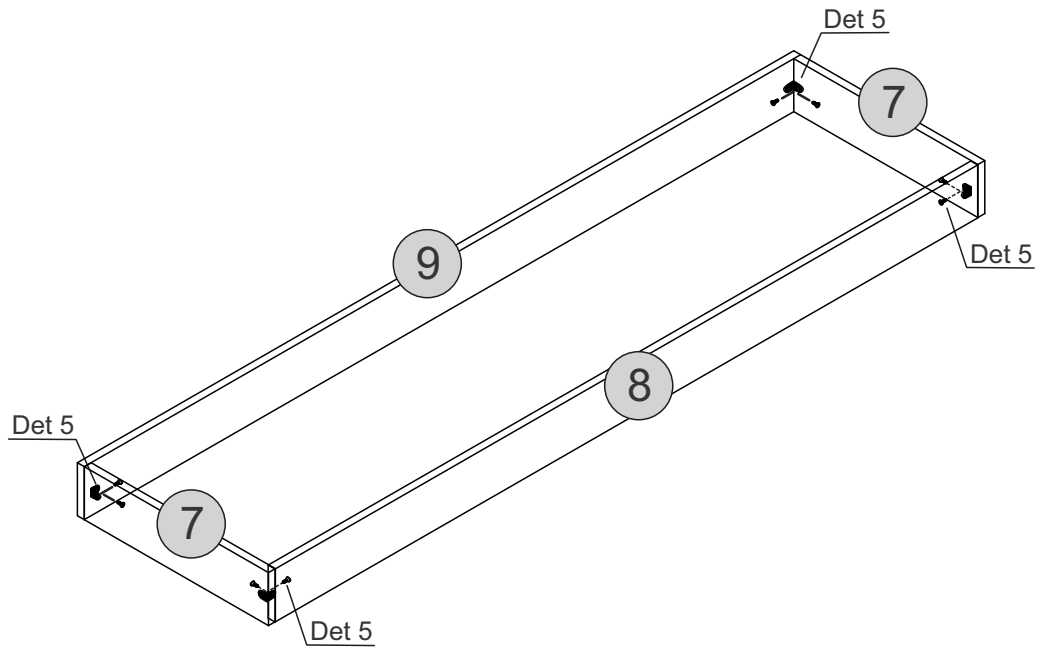

Detalle 5 / Detail 5
Detalhe 5 / Détail 5

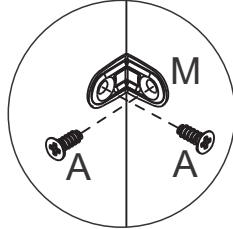

7

PIEZAS NECESARIAS
PARTS REQUIRED
PEÇAS NECESSÁRIAS
PIÈCES NÉCESSAIRES

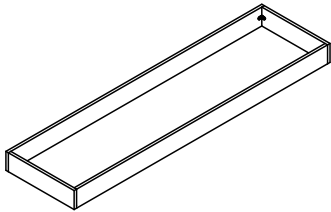

1	x1
---	----

ACCESORIOS NECESARIOS
HARDWARE REQUIRED
ACESSÓRIOS NECESSÁRIOS
ACCESSOIRES NÉCESSAIRES

D		12x
Ø4x40mm/0,16x1,57in		

HERRAMIENTAS NECESARIAS
TOOLS REQUIRED
FERRAMENTAS NECESSÁRIAS
OUTILS NÉCESSAIRES

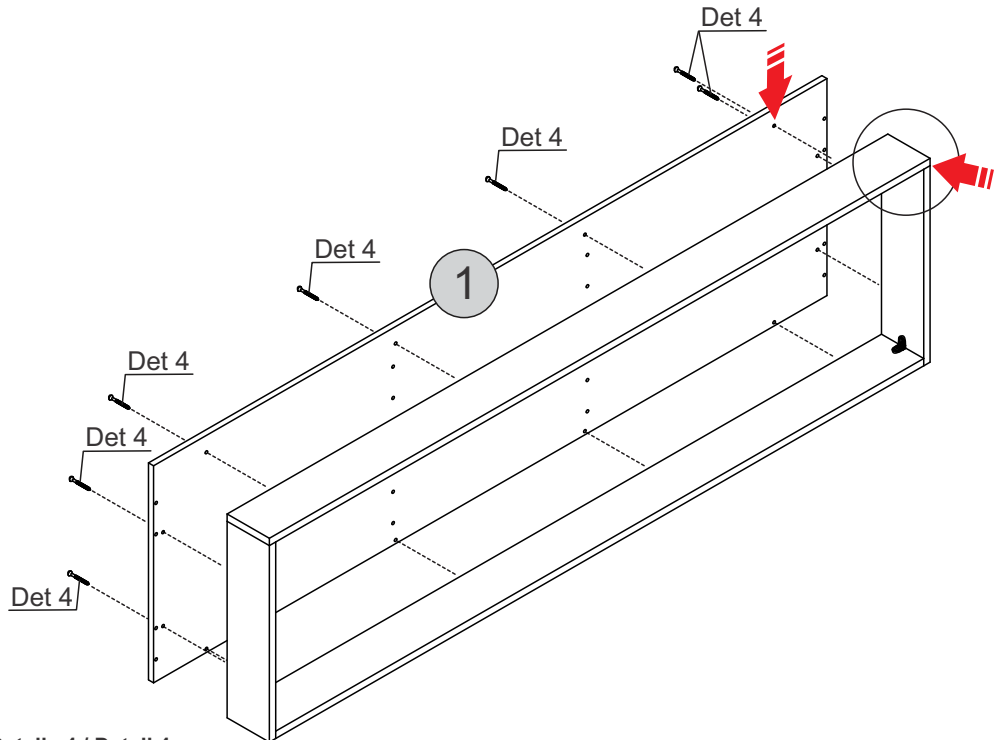
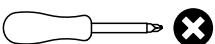

Detalle 4 / Detail 4
Detalhe 4 / Détail 4

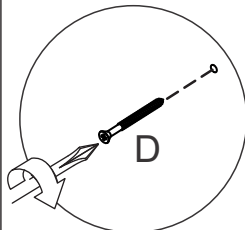

8

PIEZAS NECESARIAS
PARTS REQUIRED
PEÇAS NECESSÁRIAS
PIÈCES NÉCESSAIRES

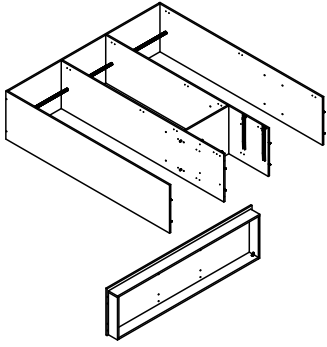

ACCESORIOS NECESARIOS
HARDWARE REQUIRED
ACESSÓRIOS NECESSÁRIOS
ACCESSOIRES NÉCESSAIRES

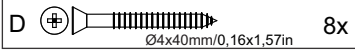

HERRAMIENTAS NECESARIAS
TOOLS REQUIRED
FERRAMENTAS NECESSÁRIAS
OUTILS NÉCESSAIRES

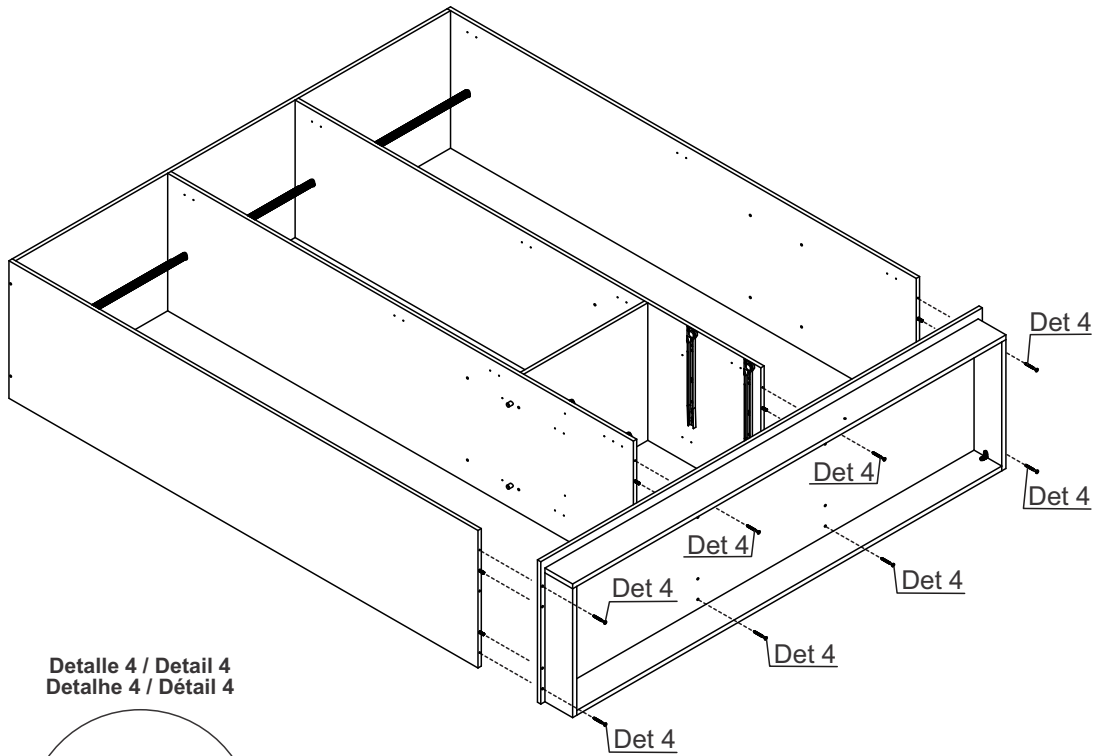
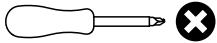

Detalle 4 / Detail 4
Detalhe 4 / Détail 4

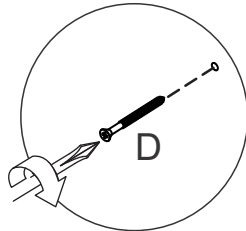

9

PIEZAS NECESARIAS
PARTS REQUIRED
PEÇAS NECESSÁRIAS
PIÈCES NÉCESSAIRES

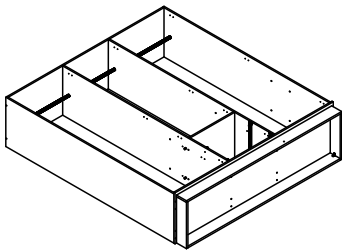

ACCESORIOS NECESARIOS
HARDWARE REQUIRED
ACESSÓRIOS NECESSÁRIOS
ACCESSOIRES NÉCESSAIRES

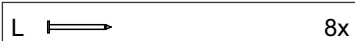

HERRAMIENTAS NECESARIAS
TOOLS REQUIRED
FERRAMENTAS NECESSÁRIAS
OUTILS NÉCESSAIRES

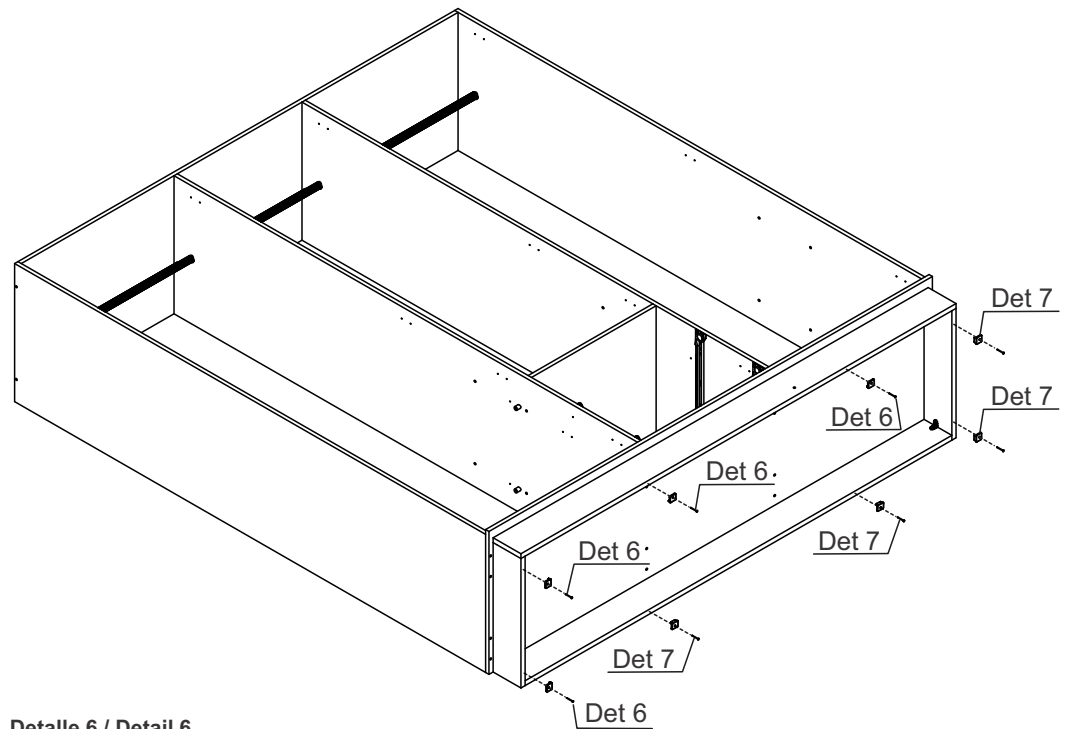
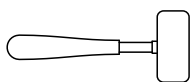

Detalle 6 / Detail 6
Detalhe 6 / Détail 6

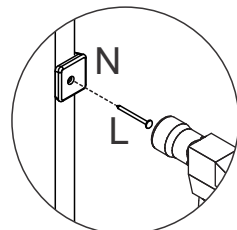

10

PIEZAS NECESARIAS
PARTS REQUIRED
PEÇAS NECESSÁRIAS
PIÈCES NÉCESSAIRES

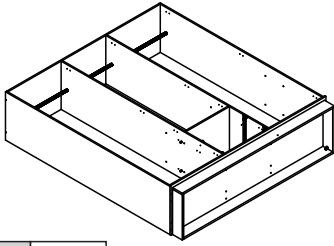

6 x4

ACCESORIOS NECESARIOS
HARDWARE REQUIRED
ACESSÓRIOS NECESSÁRIOS
ACCESSOIRES NÉCESSAIRES

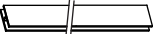
G  3x

L  87x

HERRAMIENTAS NECESARIAS
TOOLS REQUIRED
FERRAMENTAS NECESSÁRIAS
OUTILS NÉCESSAIRES

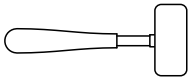

Detalle 8 / Detail 8
Detalhe 8 / Détail 8

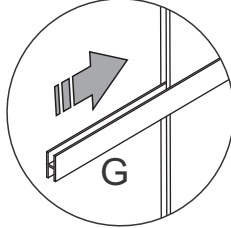

Detalle 9 / Detail 9
Detalhe 9 / Détail 9

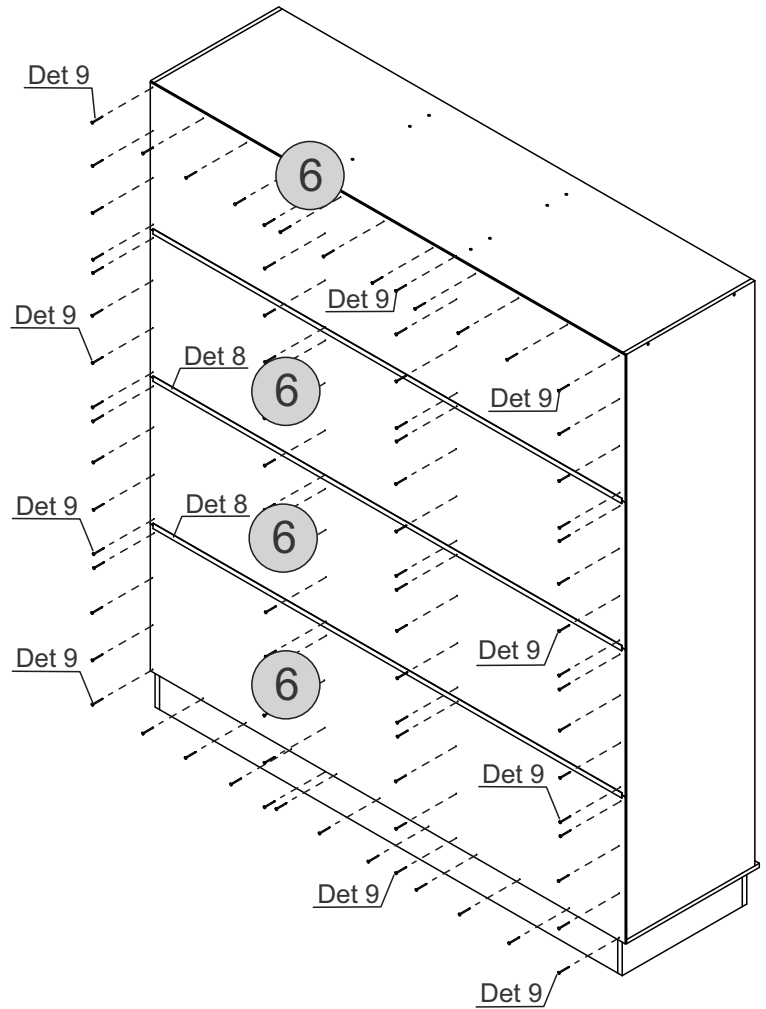
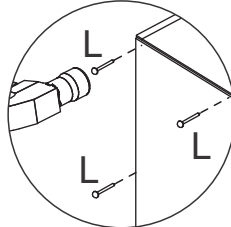

11

PIEZAS NECESARIAS
PARTS REQUIRED
PEÇAS NECESSÁRIAS
PIÈCES NÉCESSAIRES

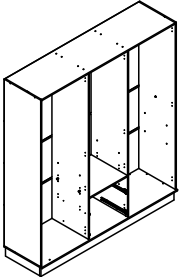

11 x1 **12** x2

ACCESORIOS NECESARIOS
HARDWARE REQUIRED
ACESSÓRIOS NECESSÁRIOS
ACCESSOIRES NÉCESSAIRES

B  15x
Ø4x20mm/0,16x0,79in

HERRAMIENTAS NECESARIAS
TOOLS REQUIRED
FERRAMENTAS NECESSÁRIAS
OUTILS NÉCESSAIRES

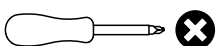

Detalle 10 / Detail 10
Detalhe 10 / Détail 10

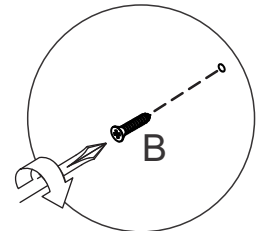

Detalle 11 / Detail 11
Detalhe 11 / Détail 11

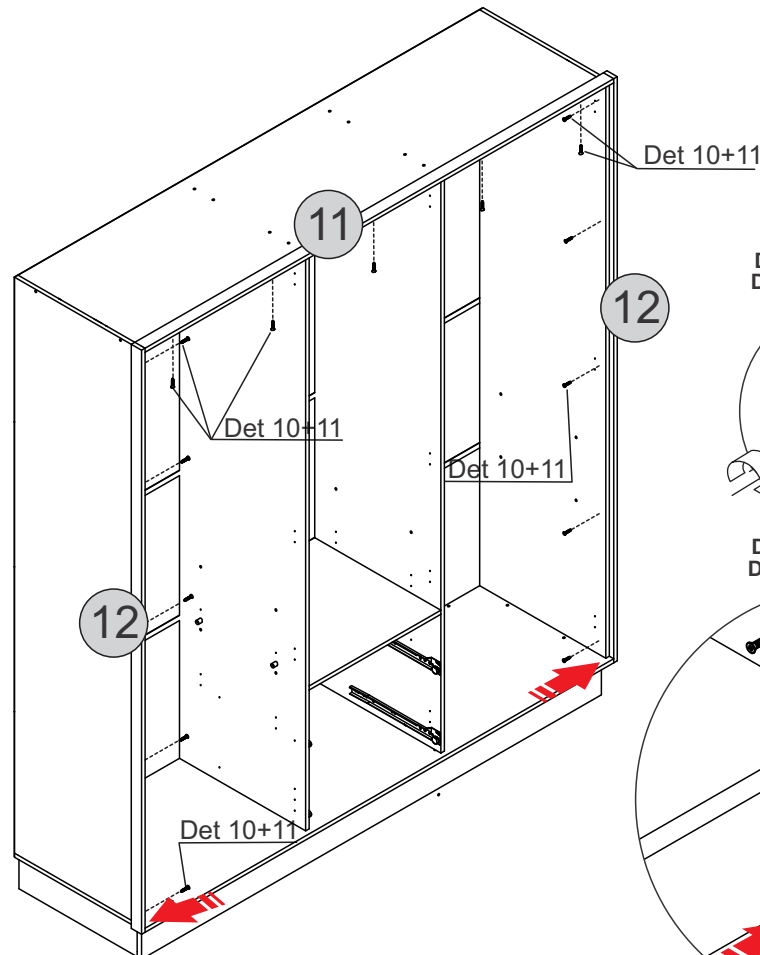
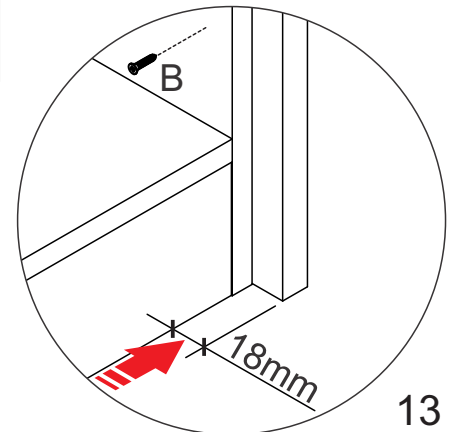

12

PIEZAS NECESARIAS
PARTS REQUIRED
PEÇAS NECESSÁRIAS
PIÈCES NÉCESSAIRES

13 x4

ACCESORIOS NECESARIOS
HARDWARE REQUIRED
ACESSÓRIOS NECESSÁRIOS
ACCESSOIRES NÉCESSAIRES

J  8x

HERRAMIENTAS NECESARIAS
TOOLS REQUIRED
FERRAMENTAS NECESSÁRIAS
OUTILS NÉCESSAIRES

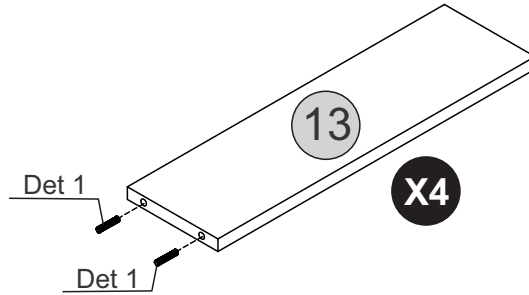
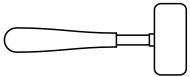

13

2x

PIEZAS NECESARIAS
PARTS REQUIRED
PEÇAS NECESSÁRIAS
PIÈCES NÉCESSAIRES

13 x4 17 x2

HERRAMIENTAS NECESARIAS
TOOLS REQUIRED
FERRAMENTAS NECESSÁRIAS
OUTILS NÉCESSAIRES

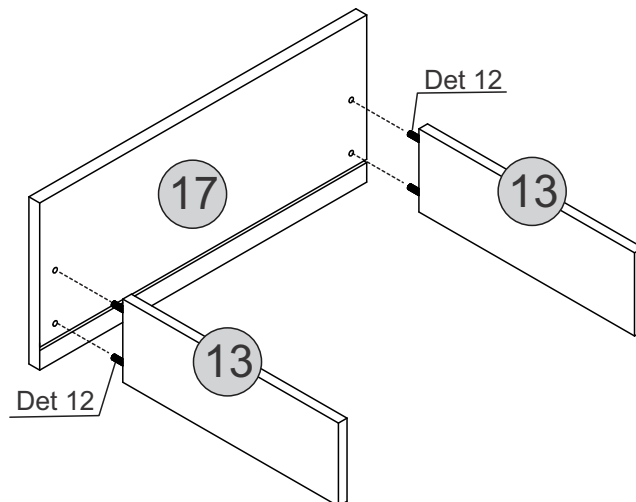
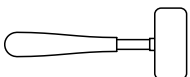

14

PIEZAS NECESARIAS
PARTS REQUIRED
PEÇAS NECESSÁRIAS
PIÈCES NÉCESSAIRES

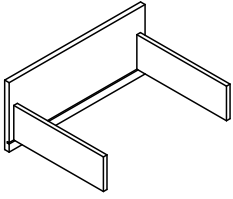

16 x1 19 x1

ACCESORIOS NECESARIOS
HARDWARE REQUIRED
ACESSÓRIOS NECESSÁRIOS
ACCESSOIRES NÉCESSAIRES

A		8x
M		4x
L		28x

HERRAMIENTAS NECESARIAS
TOOLS REQUIRED
FERRAMENTAS NECESSÁRIAS
OUTILS NÉCESSAIRES

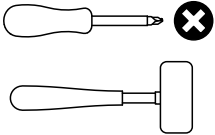

2x

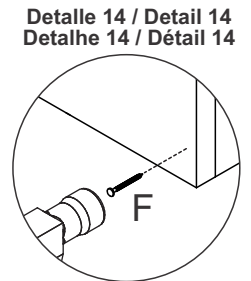
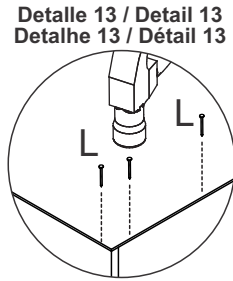
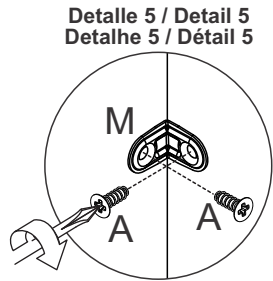
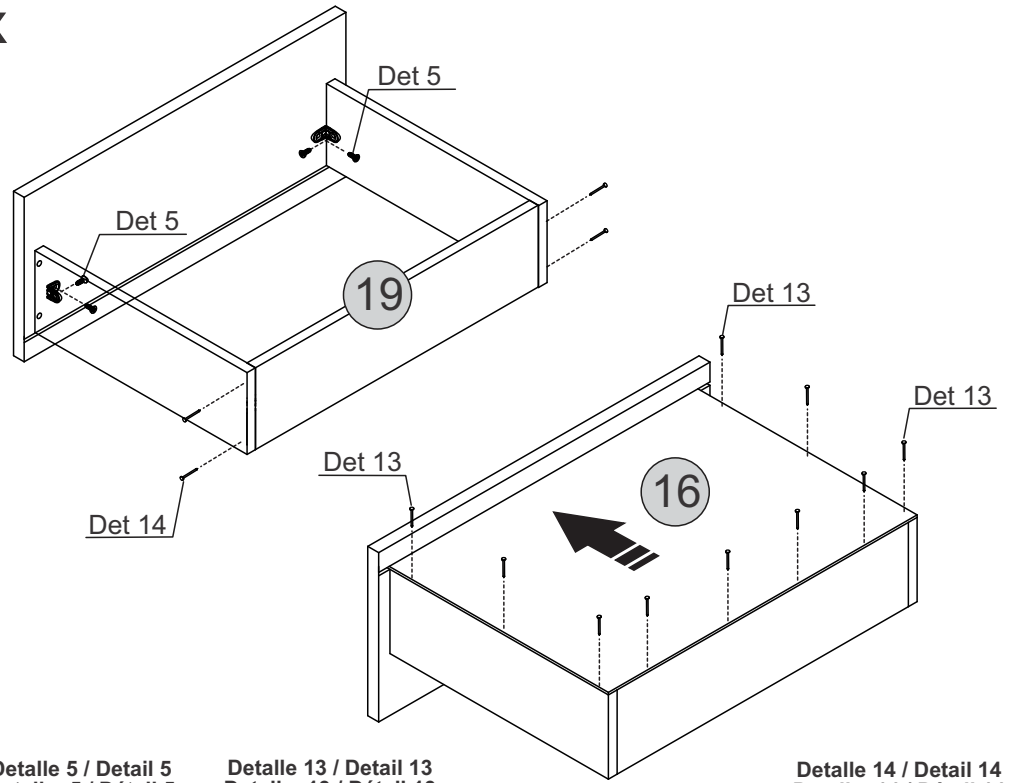

15

PIEZAS NECESARIAS
PARTS REQUIRED
PEÇAS NECESSÁRIAS
PIÈCES NÉCESSAIRES

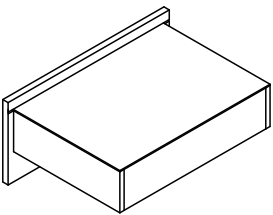

ACCESORIOS NECESARIOS
HARDWARE REQUIRED
ACESSÓRIOS NECESSÁRIOS
ACCESSOIRES NÉCESSAIRES

A		12x
K		2x
P		2x

HERRAMIENTAS NECESARIAS
TOOLS REQUIRED
FERRAMENTAS NECESSÁRIAS
OUTILS NÉCESSAIRES

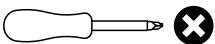

2x

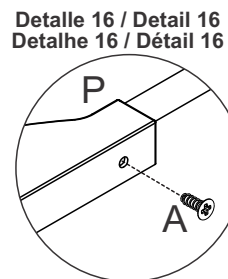
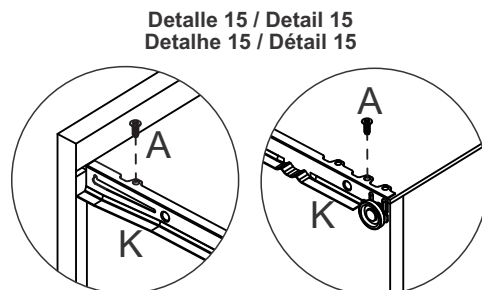
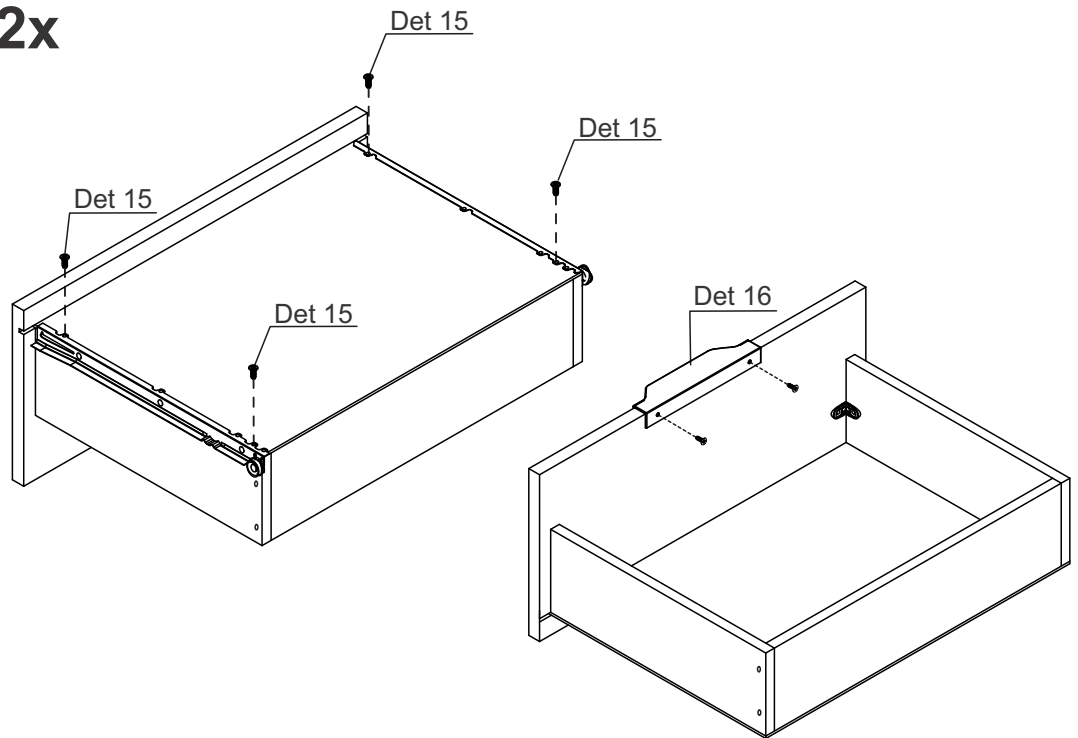

16

PIEZAS NECESARIAS
PARTS REQUIRED
PEÇAS NECESSÁRIAS
PIÈCES NÉCESSAIRES

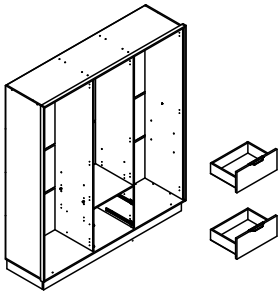

ACCESORIOS NECESARIOS
HARDWARE REQUIRED
ACESSÓRIOS NECESSÁRIOS
ACCESSOIRES NÉCESSAIRES

A		4x
Q		2x
R		1x

HERRAMIENTAS NECESARIAS
TOOLS REQUIRED
FERRAMENTAS NECESSÁRIAS
OUTILS NÉCESSAIRES

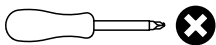

Detalle 17 / Detail 17
Detalhe 17 / Détail 17

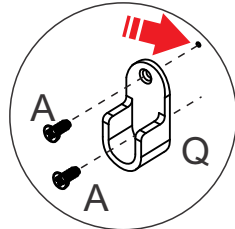

Detalle 18 / Detail 18
Detalhe 18 / Détail 18

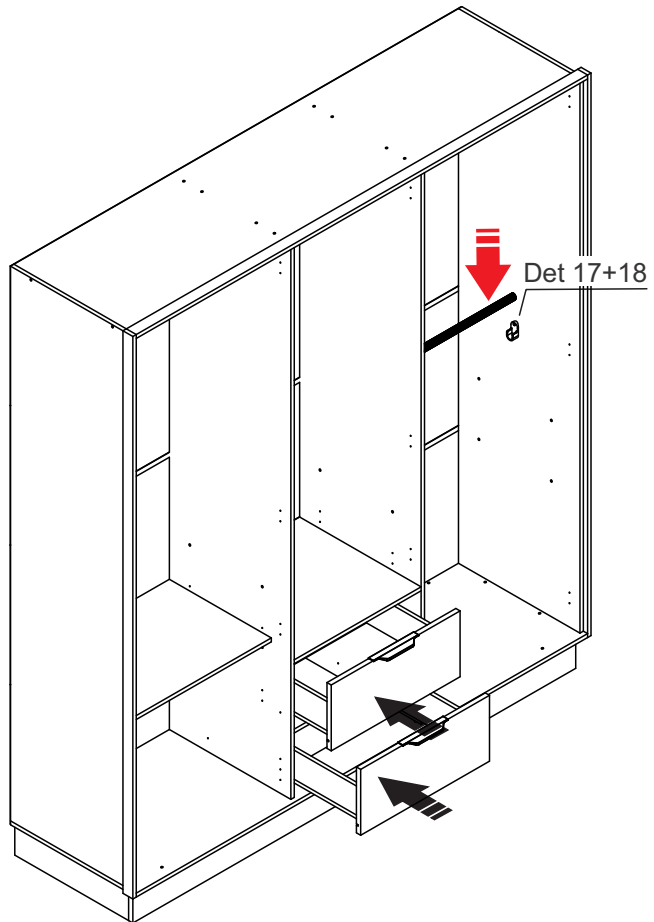
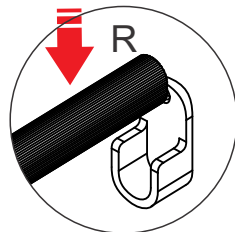

17

PIEZAS NECESARIAS
PARTS REQUIRED
PEÇAS NECESSÁRIAS
PIÈCES NÉCESSAIRES

4	x2	10	x2	21	x2
---	----	----	----	----	----

ACCESORIOS NECESARIOS
HARDWARE REQUIRED
ACESSÓRIOS NECESSÁRIOS
ACCESSOIRES NÉCESSAIRES

A		64x
E		16x
F		16x

HERRAMIENTAS NECESARIAS
TOOLS REQUIRED
FERRAMENTAS NECESSÁRIAS
OUTILS NÉCESSAIRES

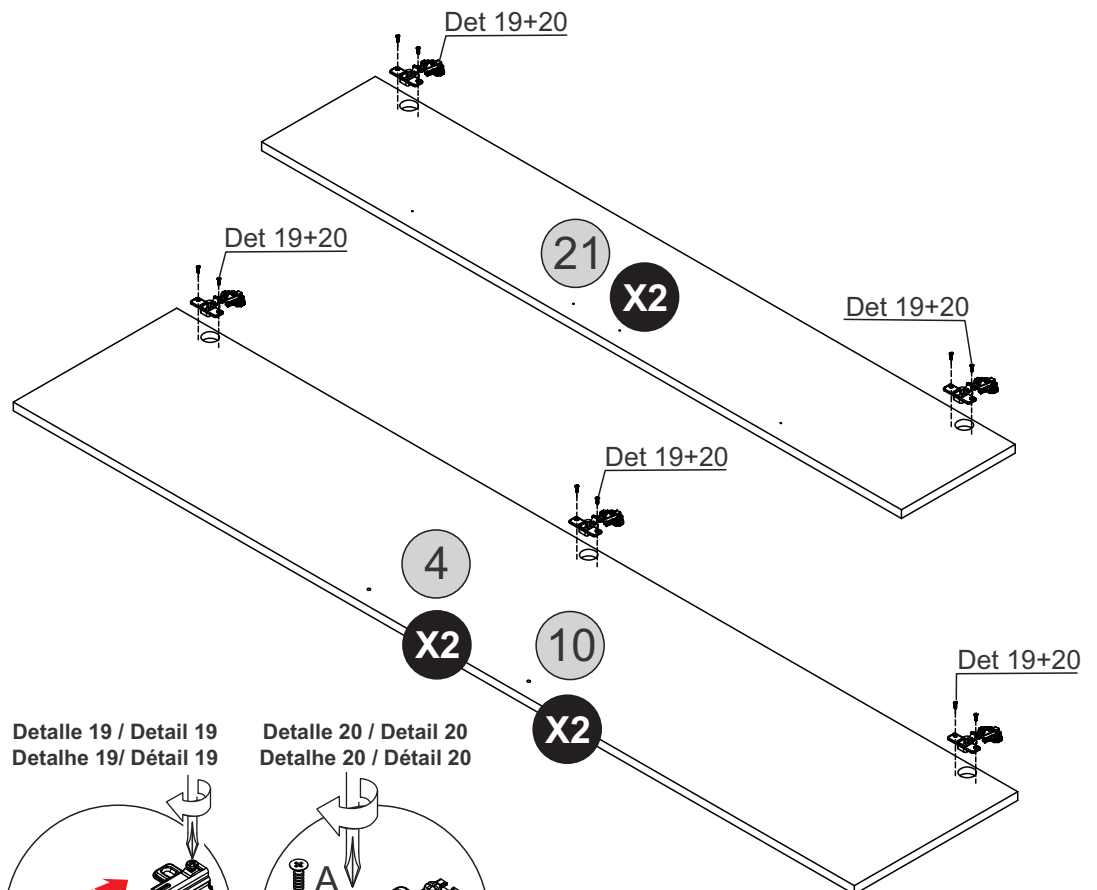
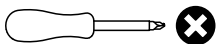

Detalle 19 / Detail 19
Detalhe 19 / Détail 19

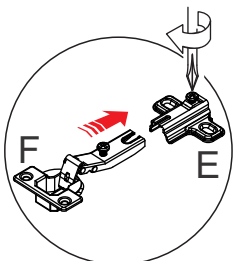

Detalle 20 / Detail 20
Detalhe 20 / Détail 20

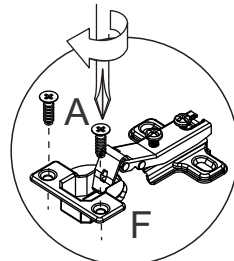

PIEZAS NECESARIAS
PARTS REQUIRED
PEÇAS NECESSÁRIAS
PIÈCES NÉCESSAIRES

ACCESORIOS NECESARIOS
HARDWARE REQUIRED
ACESSÓRIOS NECESSÁRIOS
ACCESSOIRES NÉCESSAIRES

HERRAMIENTAS NECESARIAS
TOOLS REQUIRED
FERRAMENTAS NECESSÁRIAS
OUTILS NÉCESSAIRES

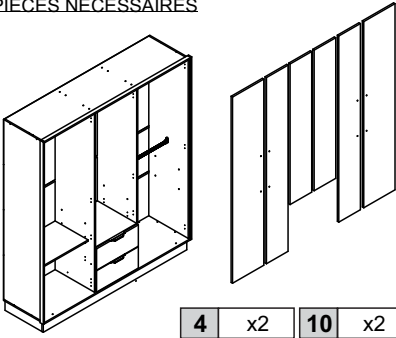

A  32x
Ø3,5x12mm/0,16x0,45in

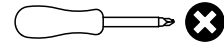

4 x2 10 x2 21 x2

Detalle 21 / Detail 21
Detalhe 21 / Détail 21

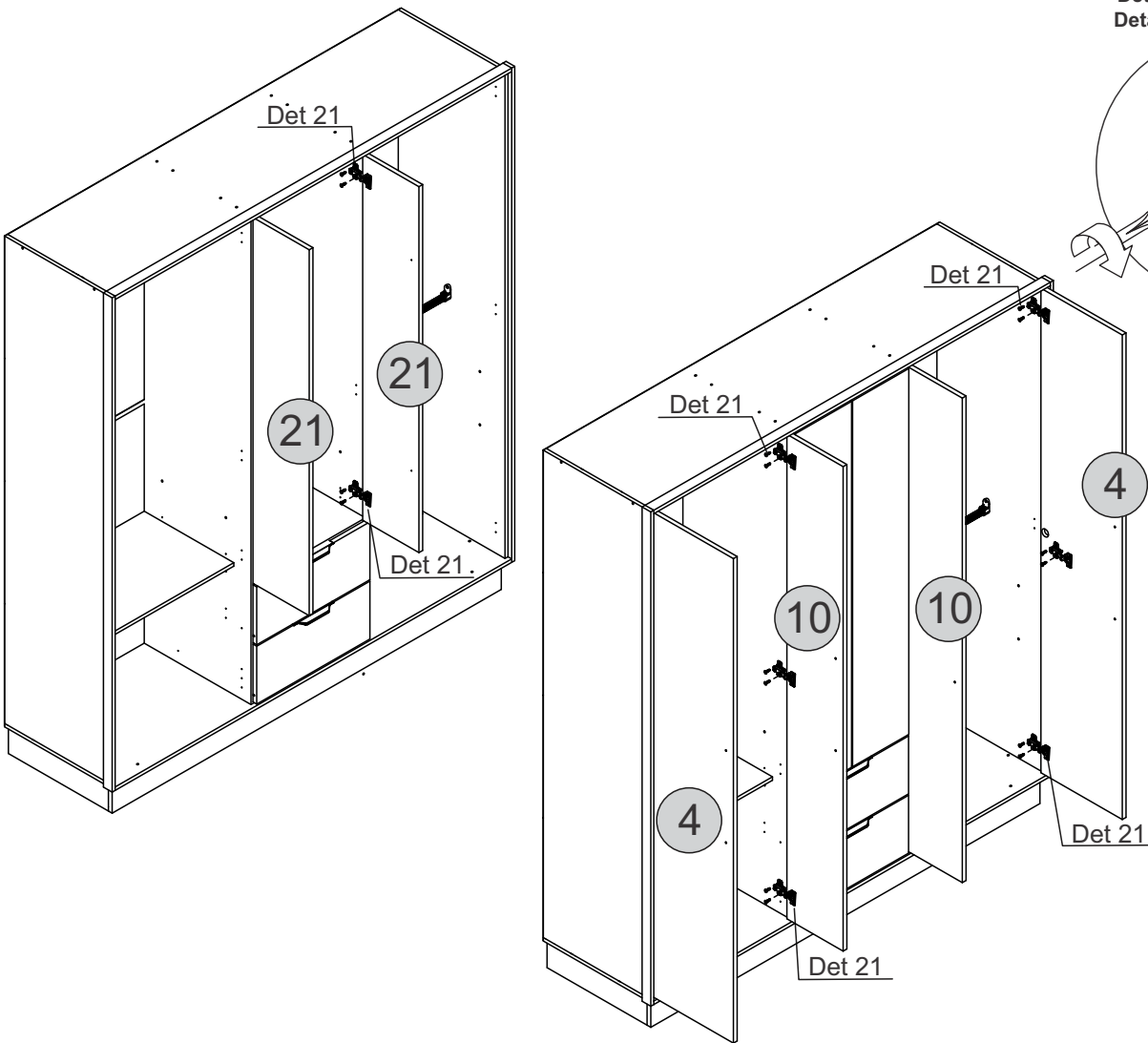

AJUSTE DE PUERTAS / DOOR ADJUSTMENT / AJUSTE DAS PORTAS / RÉGLAGE DES PORTES

Ajuste de la altura
Ajuste Altura
Height Adjustment
Réglage de la hauteur

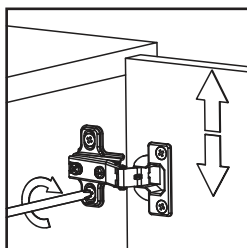

Ajuste Interno
Ajuste Interno
Internal Adjustment
Ajustement interne

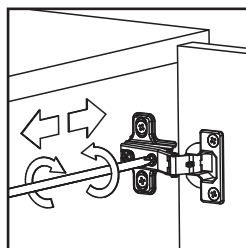

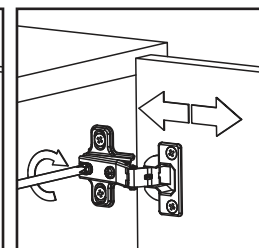
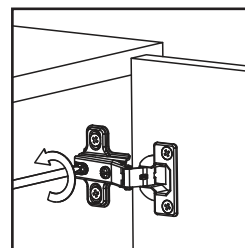

Ajuste de la profundidad
Ajuste de Profundidade
Depth Adjustment
Réglage de la profondeur

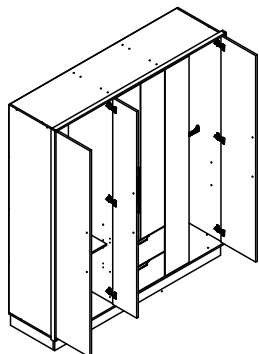

PIEZAS NECESARIAS
PARTS REQUIRED
PEÇAS NECESSÁRIAS
PIÉCES NÉCESSAIRES

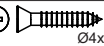

ACCESORIOS NECESARIOS
HARDWARE REQUIRED
ACESSÓRIOS NECESSÁRIOS
ACCESSOIRES NÉCESSAIRES

C		Ø4x25mm/0,16x0,98in	12x
I			6x

HERRAMIENTAS NECESARIAS
TOOLS REQUIRED
FERRAMENTAS NECESSÁRIAS
OUTILS NÉCESSAIRES

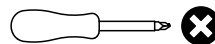

Detalle 22 / Detail 22
Detalhe 22 / Détail 22

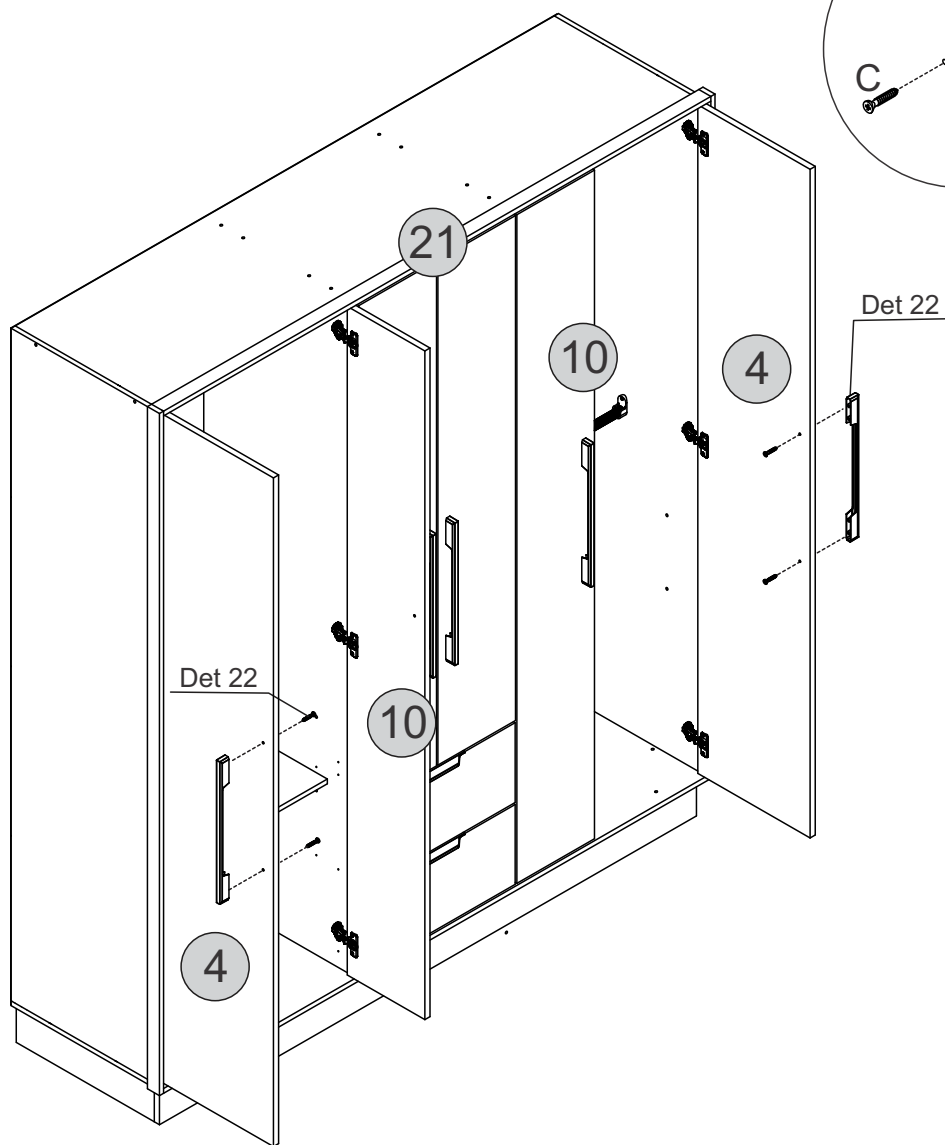
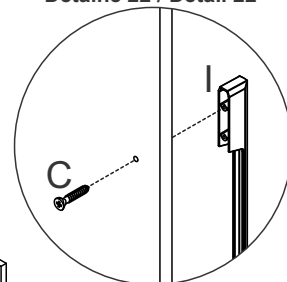

Este es el producto que ha comprado!
This is the product you have purchased!
Esse é o produto que você adquiriu!
Voici le produit que vous avez acheté!

Ref. 1170

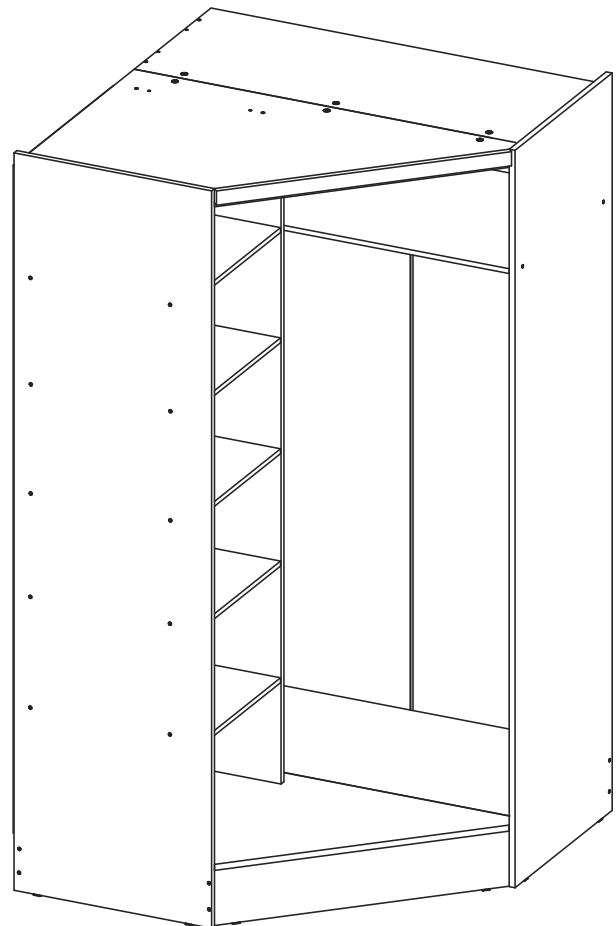
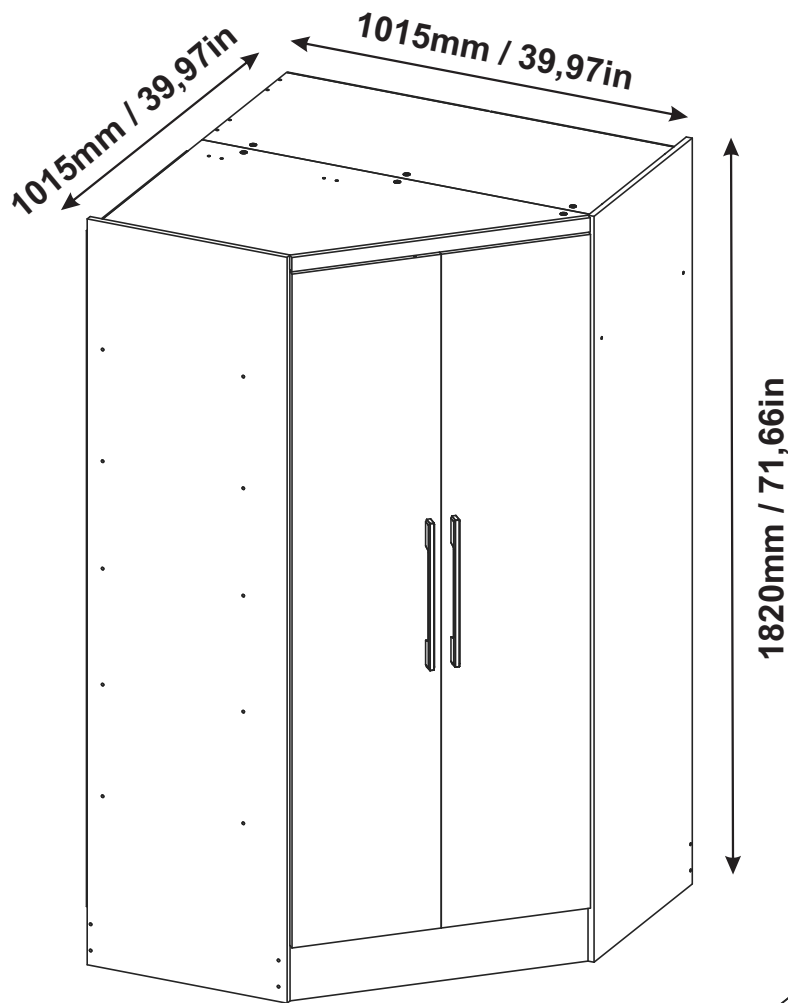

RECOMENDACIONES PARA EL USO Y CUIDADO DEL PRODUCTO
RECOMMENDATIONS FOR THE USE AND CARE OF THE PRODUCT
RECOMENDAÇÕES DE USO E CUIDADOS COM O PRODUTO
RECOMMANDATIONS POUR L'UTILISATION ET L'ENTRETIEN DU PRODUIT



ES: Lea cuidadosamente el manual y siga en el orden indicado las instrucciones de ensamble.
EN: Read the manual carefully and follow the assembly instructions in the order listed.
PT: Leia o manual com atenção e siga as instruções de montagem na ordem listada.
FR: Lisez attentivement le manuel et suivez les instructions de montage dans l'ordre indiqué.

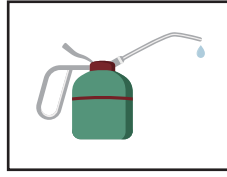

ES: Se recomienda lubricar cada 3 meses rieles, correderas, bisagras y rodachinas.
EN: It is recommended to lubricate the rails, runners, hinges and castors every 3 months.
PT: Recomenda-se a lubrificação de trilhos, corredeiras, dobradiças e rodízios a cada 3 meses.
FR: Il est recommandé de lubrifier les rails, glissières, charnières et roulettes tous les 3 mois.



ES: No pinte ni use elementos abrasivos para limpiar el mueble.
EN: Do not paint or use abrasive items to clean the furniture.
PT: Não pinte ou use itens abrasivos para limpar o móvel.
FR: Ne pas peindre ni utiliser d'objets abrasifs pour nettoyer l'armoire.



ES: No utilizar las gavetas como escaleras ni permitir que los niños se cuelguen de las puertas.
EN: Do not use drawers as ladders or allow children to hang from doors.
PT: Não use gavetas como escadas, nem permita que crianças se pendurem nas portas.
FR: N'utilisez pas les tiroirs comme échelles et ne laissez pas les enfants se suspendre aux portes.

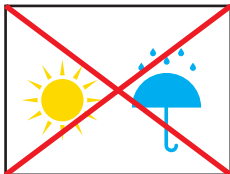

ES: No esponga el mueble al calor ni a la humedad.
EN: Do not expose the furniture to heat or humidity.
PT: Não exponha a mobília ao calor ou umidade.
FR: N'exposez pas le meuble à la chaleur ou à l'humidité.



ES: Evita que el trapeador o elementos similares entren en contacto con tus muebles ya que esto puede deteriorarlos.
EN: Avoid that the mop or similar elements come into contact with your furniture as this can deteriorate them.
PT: Evite que a esfregona ou elementos semelhantes entrem em contacto com os seus móveis, pois pode deteriorá-los.
FR: Évitez que la serpillière ou des éléments similaires entrent en contact avec vos meubles car cela peut les détériorer.



ES: - No arraste el mueble, esto puede causar daños en las piezas.
 - Para desplazar el mueble asegúrese de moverlo cuando este vacío sin objetos.
 - Siempre solicite ayuda a otra persona para moverlo.
EN: - Do not drag the furniture, this can cause damage to the pieces.
 - To move the furniture be sure to move it when it is empty without objects.
 - Always ask someone else to help you move it.



ES: Ubica tus productos en una superficie lisa y plana. Utilice una protección entre el mueble y el piso.
EN: Place your products on a smooth, flat surface. Use a protection between the furniture and the floor.
PT: Coloque seus produtos em uma superfície lisa e plana. Use uma proteção entre a mobília e o chão.
FR: Placez vos produits sur une surface lisse et plane. Utilisez une protection entre le meuble et le sol.

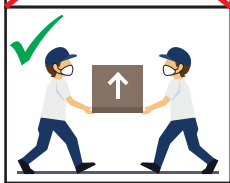

PT: - Não arraste o móvel, pois isso pode causar danos às peças.
 - Para mover o móvel certifique-se de movê-lo quando estiver vazio e sem objetos.
 - Sempre peça a outra pessoa para ajudá-lo a movê-lo.
FR: - Ne traînez pas le meuble, cela peut endommager les pièces.
 - Pour déplacer le meuble veillez à le déplacer lorsqu'il est vide sans objets.
 - Demandez toujours à quelqu'un d'autre de vous aider à le déplacer.

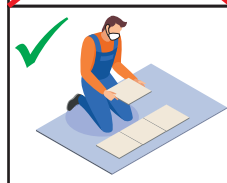

ES: No utilice papel periódico para brillar vidrios y/o espejos, esto los puede rayar. Es recomendable utilizar paños que no dejen pelusa.
EN: Do not use newspaper to shine glass and / or mirrors, this can scratch them. It is recommended to use lint-free cloths.
PT: Não use jornal para lustrar vidros e / ou espelhos, pois podem riscá-los. É aconselhável usar panos sem fiapos.
FR: N'utilisez pas de papier journal pour faire briller le verre et/ou les miroirs, cela peut les rayser. Il est conseillé d'utiliser des chiffons non pelucheux.



ES: Mantén alejado objetos puntiagudos como tijeras, llaves o cuchillos. Éstos pueden causar cortes y/o rayones.
EN: Keep sharp objects like scissors, keys, or knives away. These can cause cuts and / or scratches.
PT: Mantenha objetos pontiagudos como tesouras, chaves ou facas longe. Isso pode causar cortes e / ou arranhões.
FR: Gardez les objets pointus comme des ciseaux, des clés ou des couteaux à distance. Ceux-ci peuvent provoquer des coupures et/ou des rayures.

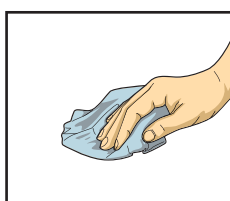

ES: Limpia regularmente la madera con un paño de microfibra para que no se acumule el polvo y así evitar que el mueble pierda su brillo.
EN: Regularly clean the wood with a microfiber cloth so that dust does not accumulate and thus prevent the furniture from losing its shine.
PT: Limpe regularmente a madeira com um pano de microfibra para que o pó não se acumule e evite que o móvel perca o brilho.
FR: Nettoyez régulièrement le bois avec un chiffon microfibre afin que la poussière ne s'accumule pas et ainsi éviter que le meuble ne perde de son éclat.



ES: Evita que el agua entre en contacto con las partes de metal, ya que puede provocar manchas y óxido.
EN: Avoid getting water on metal parts as it can cause stains and rust.
PT: Evite molhar as peças de metal, pois pode causar manchas e ferrugem.
FR: Évitez de mettre de l'eau sur les pièces métalliques car cela peut causer des taches et de la rouille.

Consejos de Conservación y Pesos soportados
Conservation Tips and Supported Weights
Dicas de Conservação e Pesos Suportados
Conseils d'entretien et Poids soutenus

ES: 1. No debe utilizarse en la limpieza, abrasivos como lana de acero, alcohol, limón, o productos corrosivos que puedan rayar o quitar la película en los muebles.

2. Cuando la limpieza de muebles en general, napa y formica, deben utilizarse un paño ligeramente humedecido y jabón suave.
3. Para mover el mueble, es importante que este se eleve desde el suelo, debido a que el arrastre puede causar daño estructural.
4. No deje el mueble en exposición a la intemperie.

EN: 1. Do not use abrasive products to clean such as steel wool, alcohol, vinegar, lemon, scouring powder, or corrosive products which can scratch or peel off the protective film of the furniture.

2. The best way to clean your furniture is to use a slightly moistened cloth with a mild soap.
3. To move the furniture assembled, it is important that it is lifted off the ground, because the drag it can cause structural damage.
4. Do not leave your furniture in weather exposure.

PT: 1. Não utilizar na limpeza produtos abrasivos tais como: palha de aço, álcool, vinagre, limão, saponáceo ou produtos corrosivos que possam riscar ou descolar a película protetora dos móveis.

2. Na limpeza de móveis em geral, naps e fórmicas, deve ser utilizado um pano levemente umedecido e sabão neutro.
3. Para a movimentação do móvel, é importante que este seja levantado do chão, pois ao arrastá-lo pode causar avarias estruturais.
4. Não deixe o móvel em exposição a intempéries.

FR: 1. Ne pas utiliser de produits abrasifs dans le nettoyage, tels que: laine d'acier, alcool, vinaigre, citron, poudre à récurer ou autres produits corrosifs pouvant rayer ou faire décoller la pellicule protectrice des meubles.

2. Pour le nettoyage du meuble, il est recommandé d'utiliser un chiffon humide et du savon neutre.
3. Pour déplacer le meuble, il est important de le soulever du sol car le tirer pourrait causer des dommages dans sa structure.
4. Ne pas exposer le meuble aux intempéries.

ES: Por favor, preste atención a los pesos máximos admitidos por cada compartimento del producto. Tenga cuidado de no exceder estos pesos, con el fin de garantizar la calidad y durabilidad del producto. Es importante recordar que los pesos muestran en caso de ser DISTRIBUIDA en toda el área de la plataforma.

EN: Please pay attention to the maximum weights supported by each compartment product. Be careful not to exceed these weights, in order to ensure the quality and durability of the product. It is important to remember also that the weights shown should be DISTRIBUTED throughout the area of the shelf.

PT: Por favor, preste atenção aos pesos máximos suportados por cada compartimento do produto. Cuide para não exceder esses pesos, afim de garantir a qualidade e a durabilidade do mesmo. É importante lembrar também que, os pesos mostrados devem ser DISTRIBUÍDOS ao longo de toda a área da peça.

FR: Veuillez faire attention aux poids maximums supportés par chaque produit du compartiment. Veuillez à ne pas dépasser ces poids, afin de garantir la qualité et la durabilité du produit. Il est également important de se rappeler que les poids indiqués doivent être RÉPARTIS sur toute la surface du rayon.

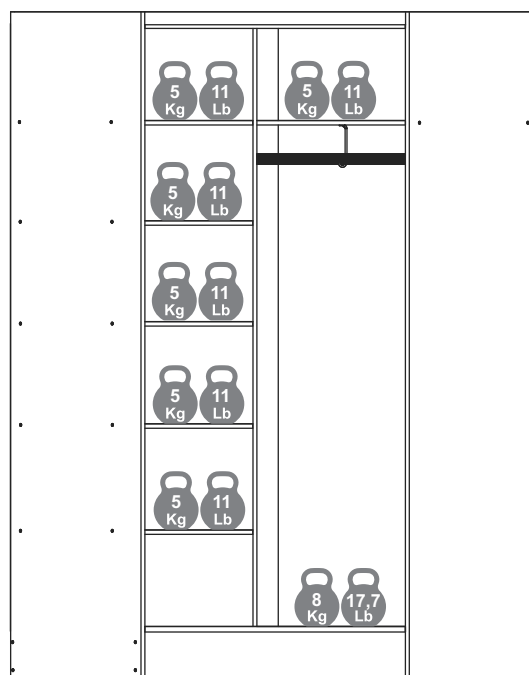



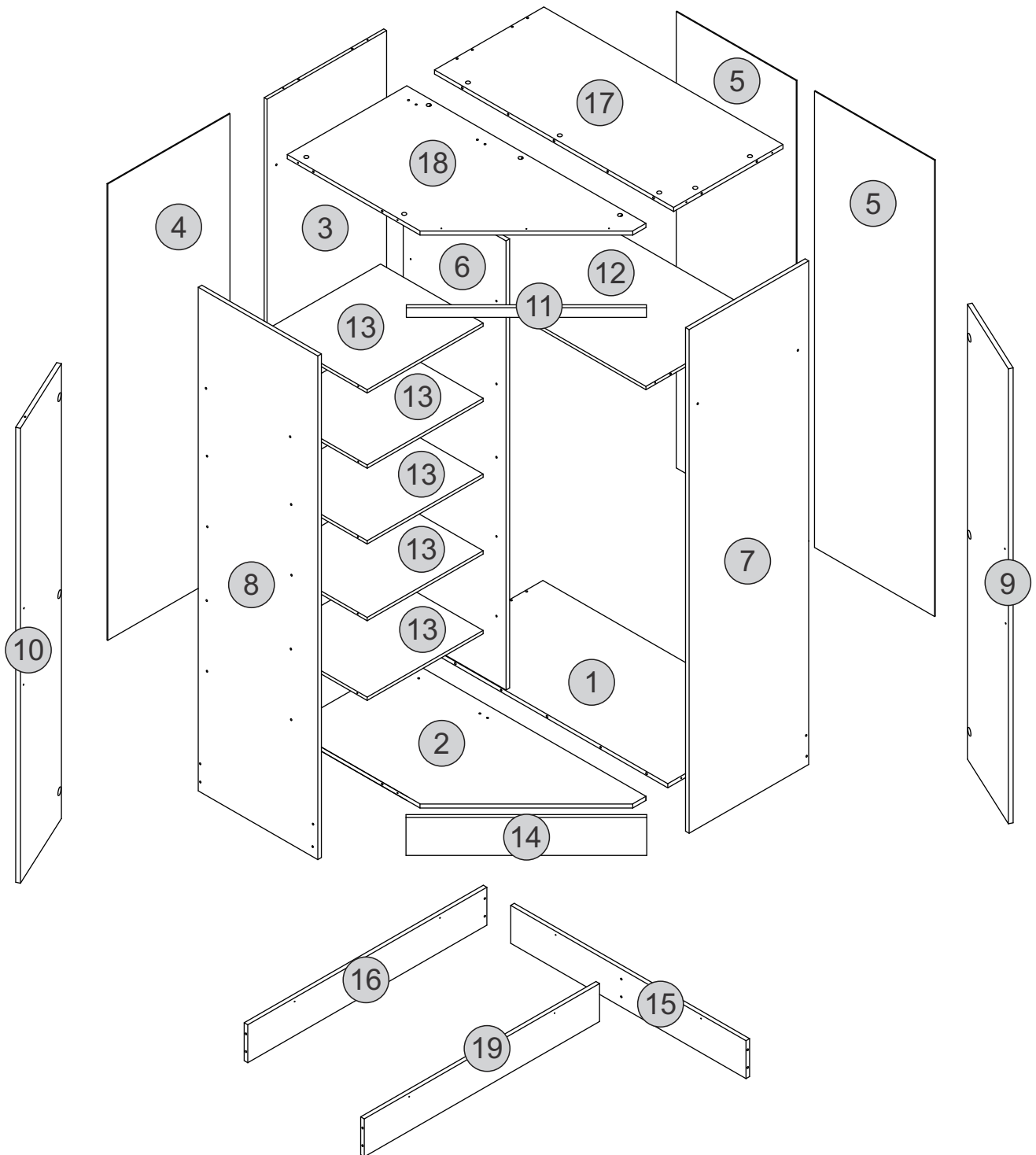







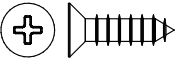
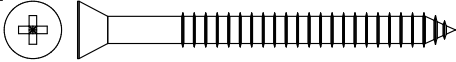

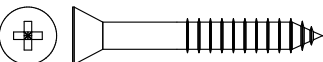
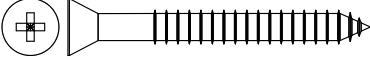
Conocer mejor las piezas de su producto
Getting to know your product parts better
Conhecendo melhor as peças do seu produto
Mieux connaître les pièces de votre produit

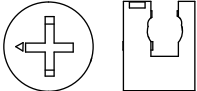
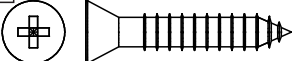
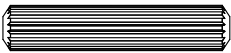

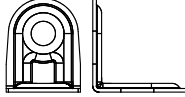
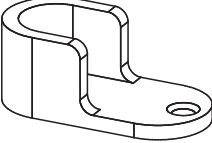
Conocer mejor las piezas de su producto
Getting to know your product parts better
Conhecendo melhor as peças do seu produto
Mieux connaître les pièces de votre produit

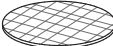
#	Ct. Qt.	Español	English	Português	Français	mm in
1	1	Base	Base	Base	Fond	1000 x 430 x 15 mm 39,37 x 16,93 x 0,59 in
2	1	Base Angular	Angled Base	Base Angulada	Fond Angulaire	1000 x 570 x 15 mm 39,37 x 22,44 x 0,59 in
3	1	Panel Trasero	Backboard	Painel Traseiro	Panneau Arrière	1623 x 500 x 12 mm 63,90 x 19,69 x 0,49 in
4	1	Costado Mayor	Large Back Panel	Costa Maior	Pièce Arrière Grand	1649 x 511 x 3 mm 64,93 x 20,12 x 0,12 in
5	2	Costado Menor	Small Back Panel	Costa Menor	Pièce Arrière Petit	1649 x 502 x 3 mm 64,93 x 19,77 x 0,12 in
6	1	División	Division	Divisão	Séparateur	1623 x 430 x 15 mm 63,90 x 16,93 x 0,59 in
7	1	Lateral Derecha	Right Side	Lateral Direita	Coté Droit	1820 x 500 x 15 mm 71,66 x 19,69 x 0,59 in
8	1	Lateral Izquierda	Left Side	Lateral Esquerda	Coté Gauche	1820 x 500 x 15 mm 71,66 x 19,69 x 0,59 in
9	1	Puerta Derecha	Right Door	Porta Direita	Porte Droit	1644 x 354 x 15 mm 64,73 x 13,94 x 0,59 in
10	1	Puerta Izquierda	Left Door	Porta Esquerda	Porte Gauche	1644 x 354 x 15 mm 64,73 x 13,94 x 0,59 in
11	1	Marco Superior	Upper Frame	Moldura Superior	Cadre Supérieur	708 x 35 x 15 mm 27,88 x 1,38 x 0,59 in
12	1	Repisa Mayor	Large Shelf	Prateleira Maior	Étagère Grand	988 x 499 x 12 mm 38,90 x 19,65 x 0,49 in
13	5	Repisa Menor	Small Shelf	Prateleira Menor	Étagère Petit	485 x 429 x 12 mm 19,10 x 16,89 x 0,49 in
14	1	Zócalo Delantero	Front Baseboard	Rodapé Dianteiro	Socle Avanti	715 x 137 x 15 mm 28,15 x 5,40 x 0,59 in
15	1	Zócalo Trasero	Back Baseboard	Rodapé Traseiro	Socle Arrière	984 x 137 x 15 mm 38,75 x 5,40 x 0,59 in
16	1	Zócalo Mayor Lateral	Large Side Baseboard	Rodapé Maior Lateral	Socle Grand Coté	1000 x 137 x 15 mm 39,37 x 5,40 x 0,59 in
17	1	Tapa	Top panel	Tampo	Dessus Tiroir	1000 x 430 x 15 mm 39,37 x 16,93 x 0,59 in
18	1	Tapa Angular	Angled Top Panel	Tampo Angulado	Dessus Tiroir Angulaire	1000 x 570 x 15 mm 39,37 x 22,44 x 0,59 in
19	1	Zócalo Interno	Internal Baseboard	Rodapé Interno	Socle Interne	984 x 137 x 15 mm 38,75 x 5,40 x 0,59 in

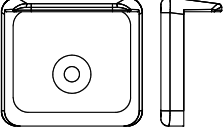
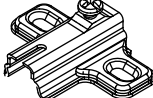
**Y estos son sus Accesorios
And these are your Accessories
E estes são os seus Acessórios
ET voici vos Accessoires**

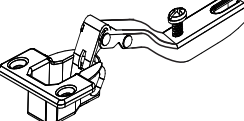
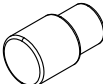
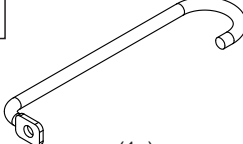
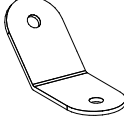
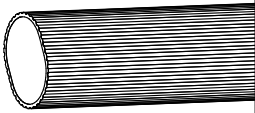
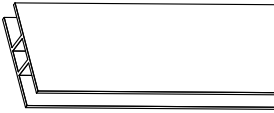
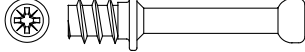
A  Ø4,0x14mm/0,16x0,56in (54x)	B  Ø4,0x50mm/0,16x1,97in (42x)	C  (6x)	
E  Ø4,0x30mm/0,16x1,18in (4x)	F  Ø3,5x40mm/0,14x1,58in (5x)	G  (125x)	H  (20x)
I  Ø4,0x25mm/0,16x0,99in (12x)	J  Ø6,0x30mm/0,24x1,18in (12x)	K  Ø8,0x40mm/0,32x1,58in (4x)	L  (11x)
M  (2x)	N  (1x)	O  (14x)	P  (20x)
Q  Ø8,0x30mm/0,32x1,18in (8x)	R  (12x)	S  (6x)	T  (2x)
U  (6x)	V  (2x)	W  (1x)	X  (1x)
Y  (1x)	Z  (1x)	A1  (8x)	

Y si lo necesitas, mide en la regla al lado
 And if you need to, measure on the ruler beside
 E se precisar, meça na régua ao lado
 ET si vous en avez besoin, mesurez sur la règle à côté

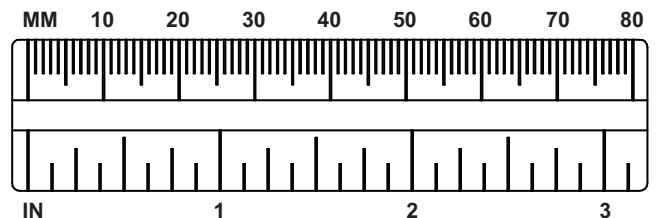

NÚMERO DE PERSONAS Y ÁREA DE ARMADO
 NUMBER OF PEOPLE AND ASSEMBLY AREA
 NÚMERO DE PESSOAS E ÁREA DE MONTAGEM
 NOMBRE DE PERSONNES ET ZONE DE RASSEMBLEMENT

HERRAMIENTAS NECESARIAS / TOOLS REQUIRED / FERRAMENTAS NECESSÁRIAS / OUTILS NÉCESSAIRES

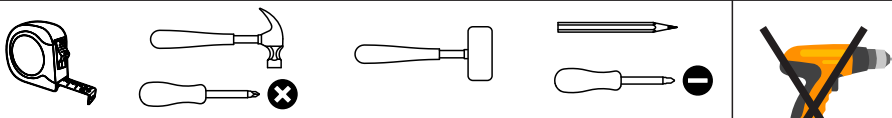

ES: NO UTILICE UN DESTORNILLADOR ELÉCTRICO O A BATERÍADO
 EN: NOT USE A BATTERY OR ELECTRIC SCREWDRIVER
 PT: NÃO UTILIZE PARAFUSADEIRA ELÉTRICA OU À BATERIA
 FR: NE PAS UTILISER DE TOURNEVIS ÉLECTRIQUE OU À BATTERIE

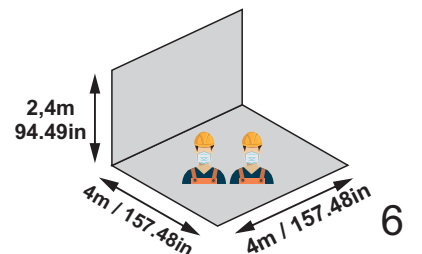

1

Detalle 1.2 / Detail 1.2
Detalhe 1.2 / Détail 1.2

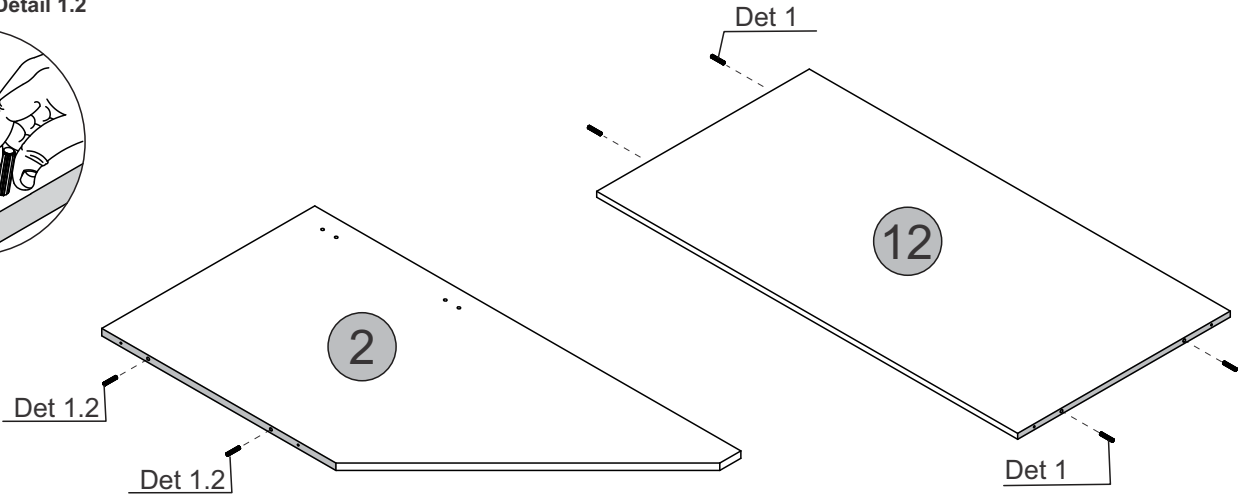

Detalle 1 / Detail 1
Detalhe 1 / Détail 1

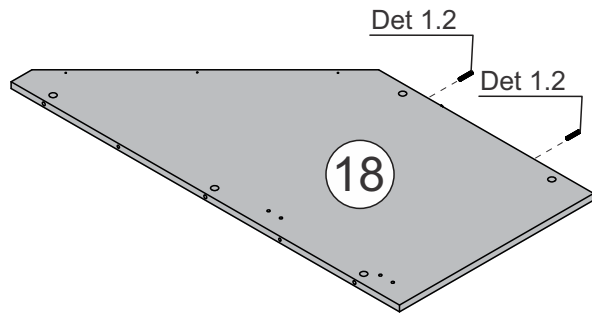

2

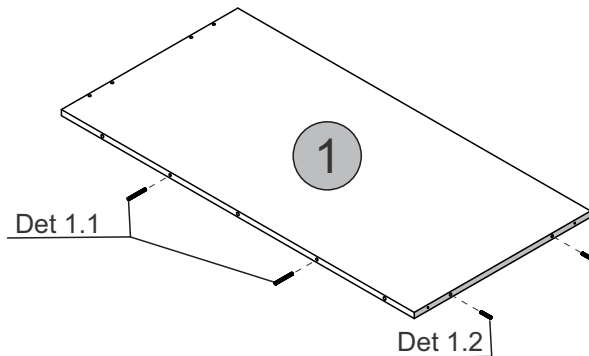
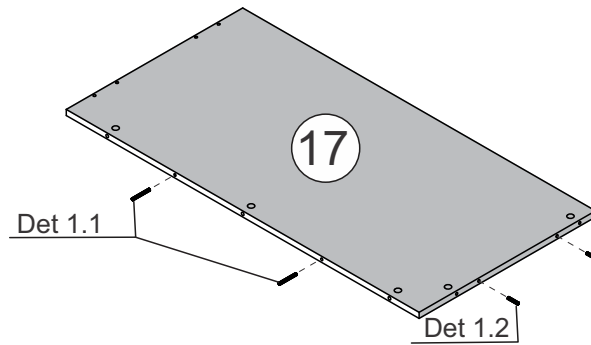

Detalle 1.1 / Detail 1.1
Detalhe 1.1 / Détail 1.1



Detalle 1.2 / Detail 1.2
Detalhe 1.2 / Détail 1.2



3

Detalle 2 / Detail 2
Detalhe 2 / Détail 2

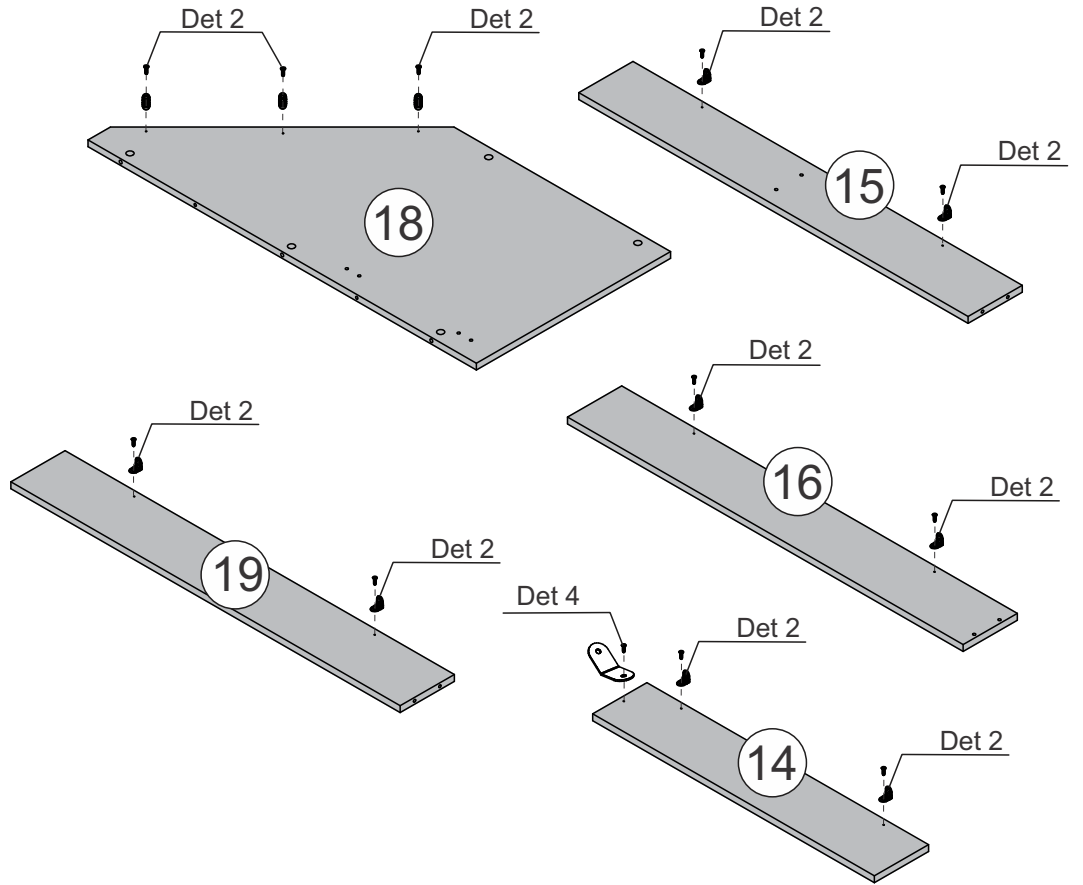
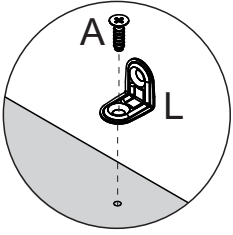

Detalle 4 / Detail 4
Detalhe 4 / Détail 4

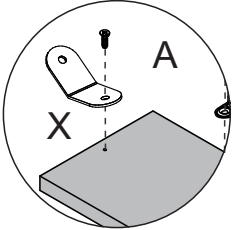

4

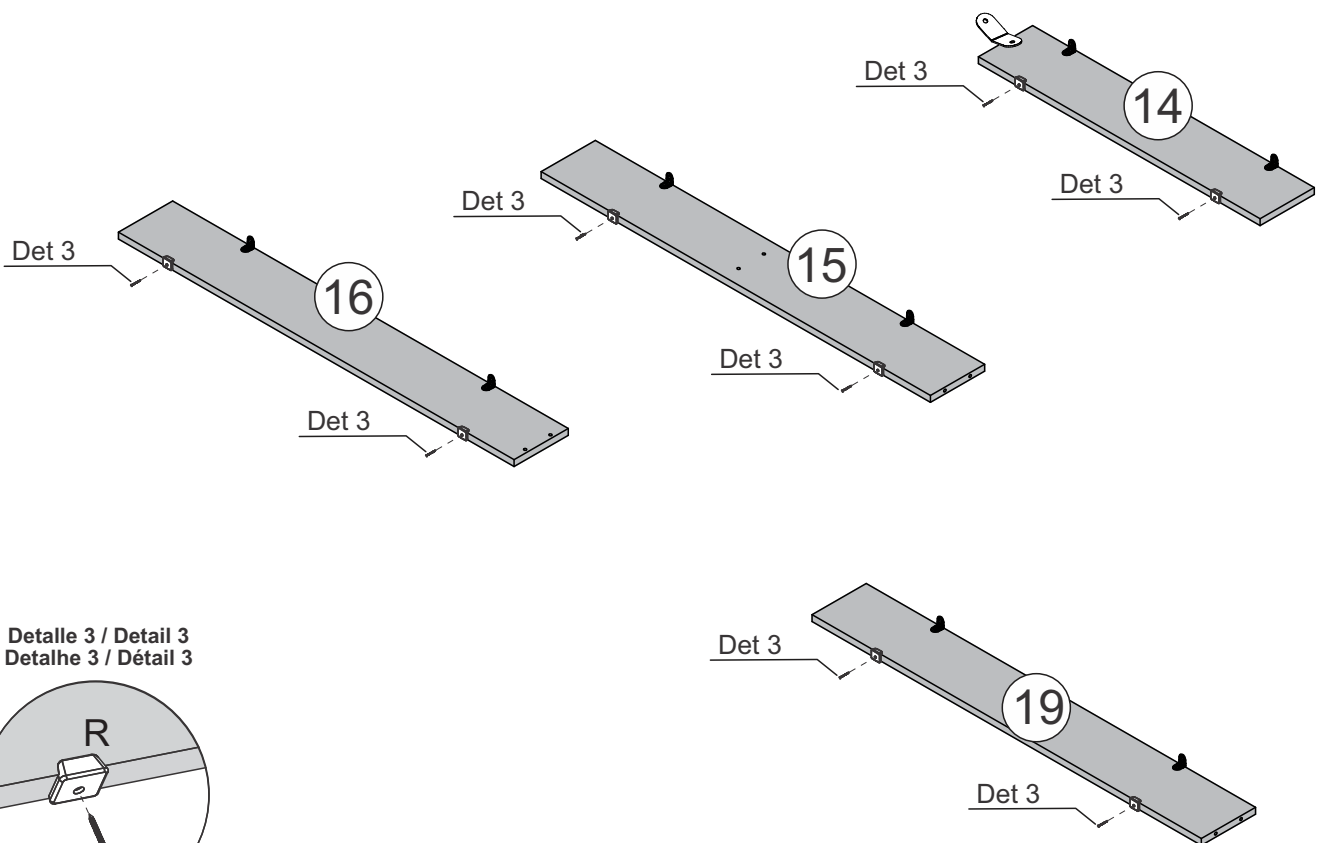

Detalle 3 / Detail 3
Detalhe 3 / Détail 3

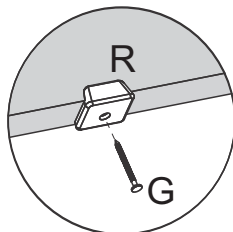

5

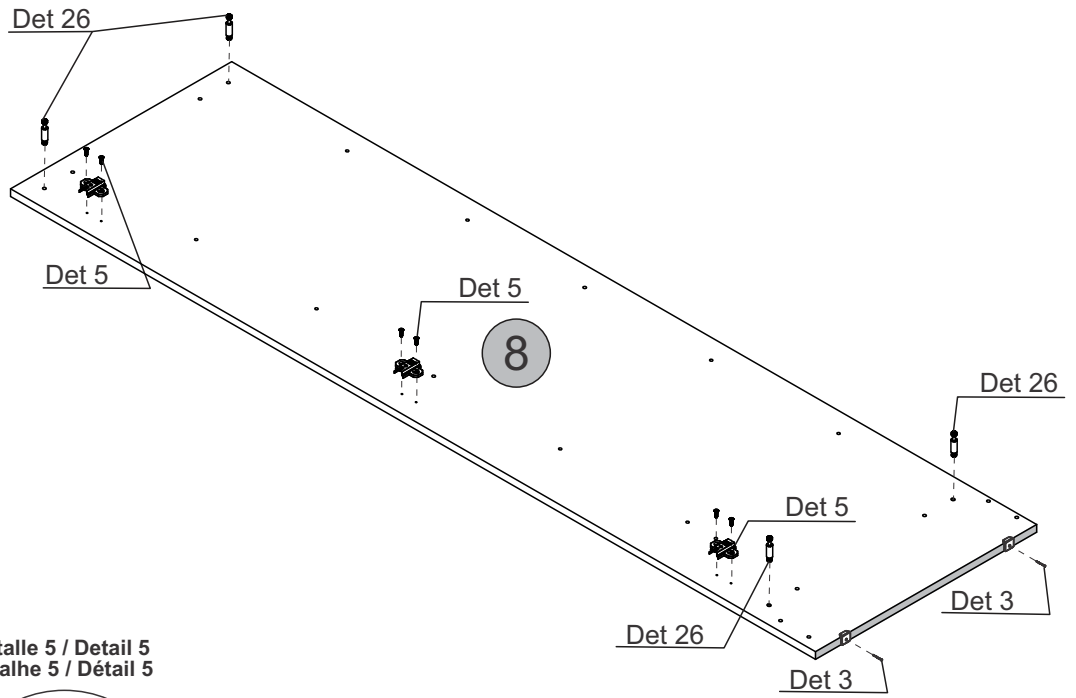

Detalle 26 / Detail 26
Detalhe 26 / Détail 26

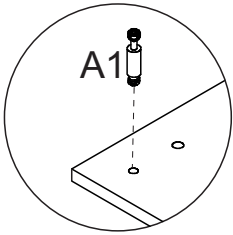

Detalle 3 / Detail 3
Detalhe 3 / Détail 3

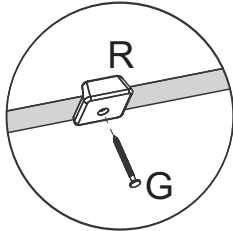

Detalle 5 / Detail 5
Detalhe 5 / Détail 5

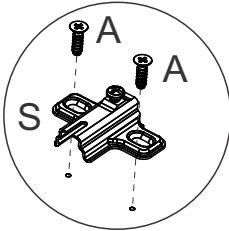

6

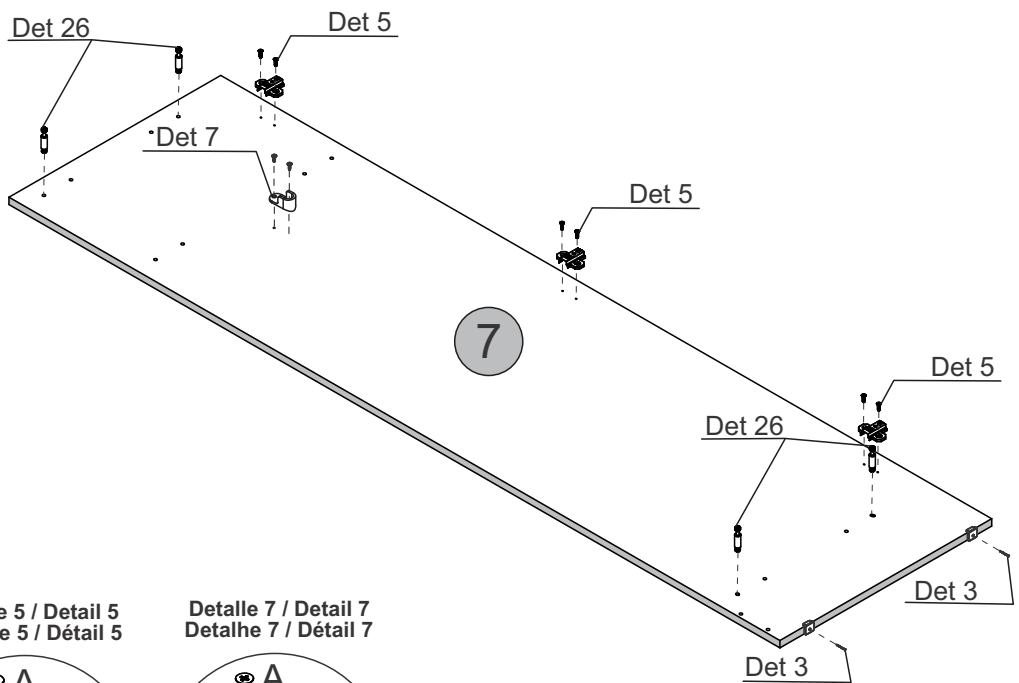

Detalle 26 / Detail 26
Detalhe 26 / Détail 26

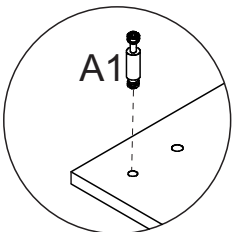

Detalle 3 / Detail 3
Detalhe 3 / Détail 3

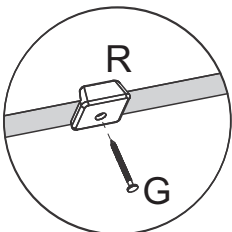

Detalle 5 / Detail 5
Detalhe 5 / Détail 5

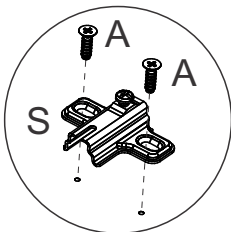

Detalle 7 / Detail 7
Detalhe 7 / Détail 7

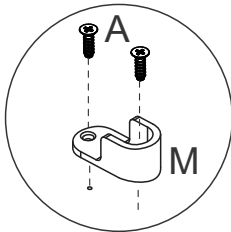

7

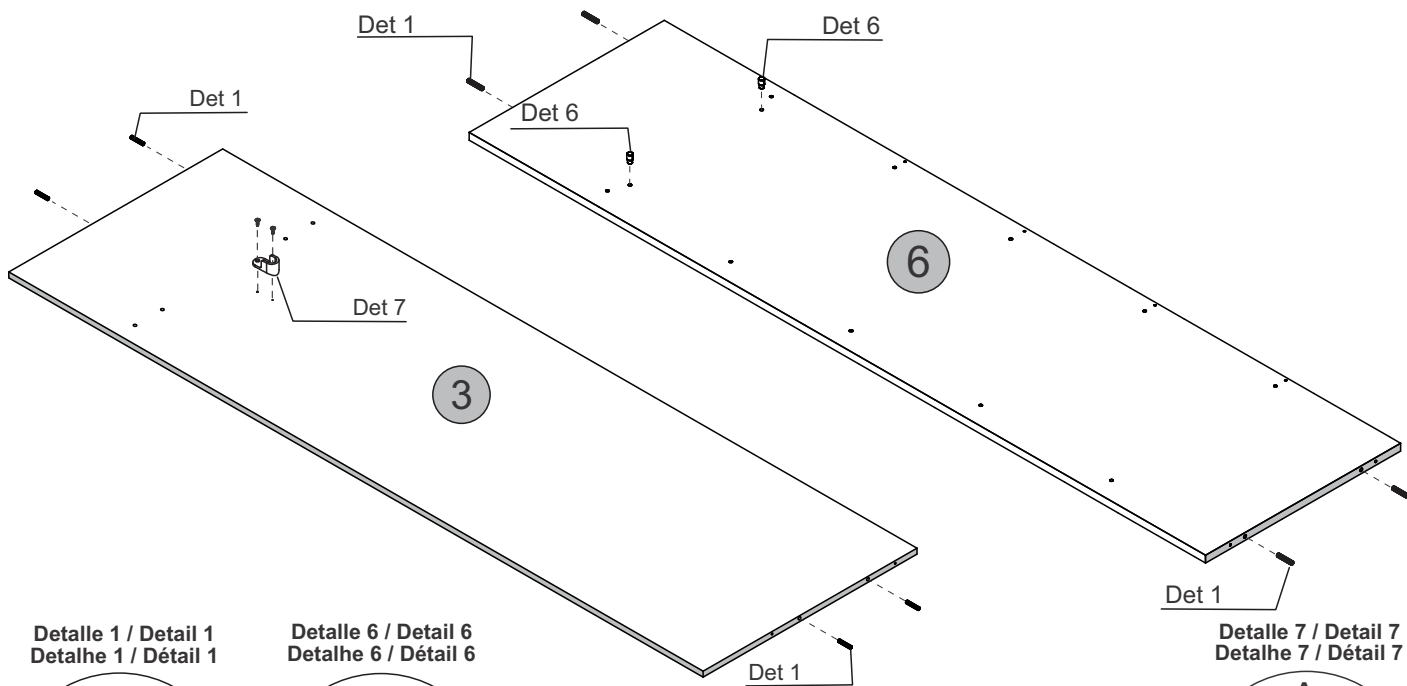

Detalle 1 / Detail 1
Detalhe 1 / Détail 1

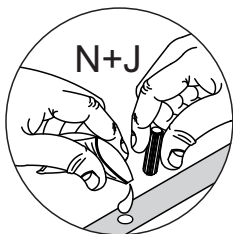

Detalle 6 / Detail 6
Detalhe 6 / Détail 6

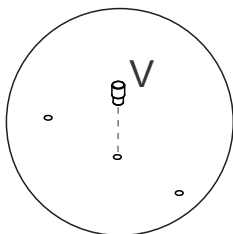

Detalle 7 / Detail 7
Detalhe 7 / Détail 7

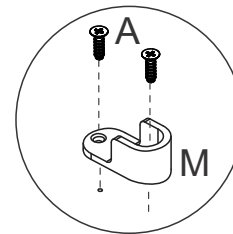

8

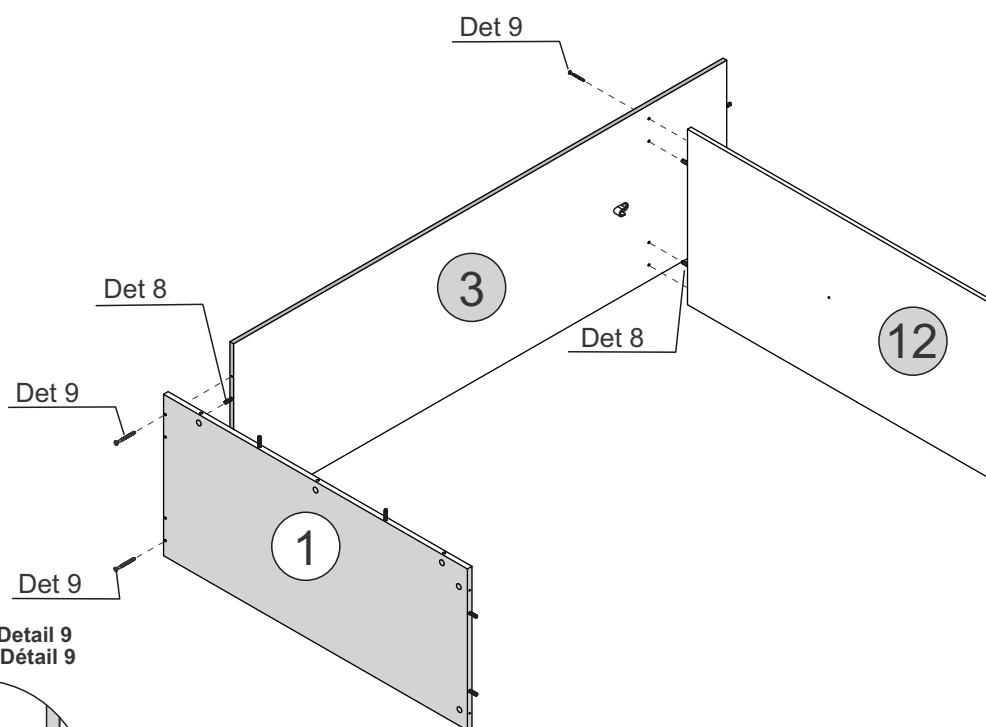

Detalle 8 / Detail 8
Detalhe 8 / Détail 8

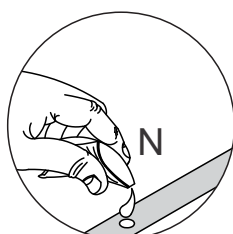

Detalle 9 / Detail 9
Detalhe 9 / Détail 9

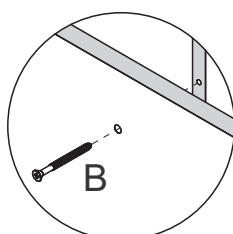

9

Detalle 10 / Detail 10
Detalhe 10 / Détail 10

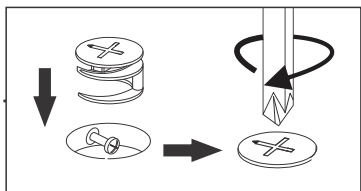
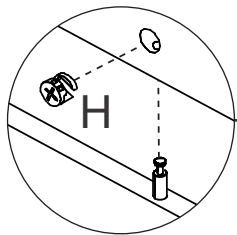

Det 8

Det 9

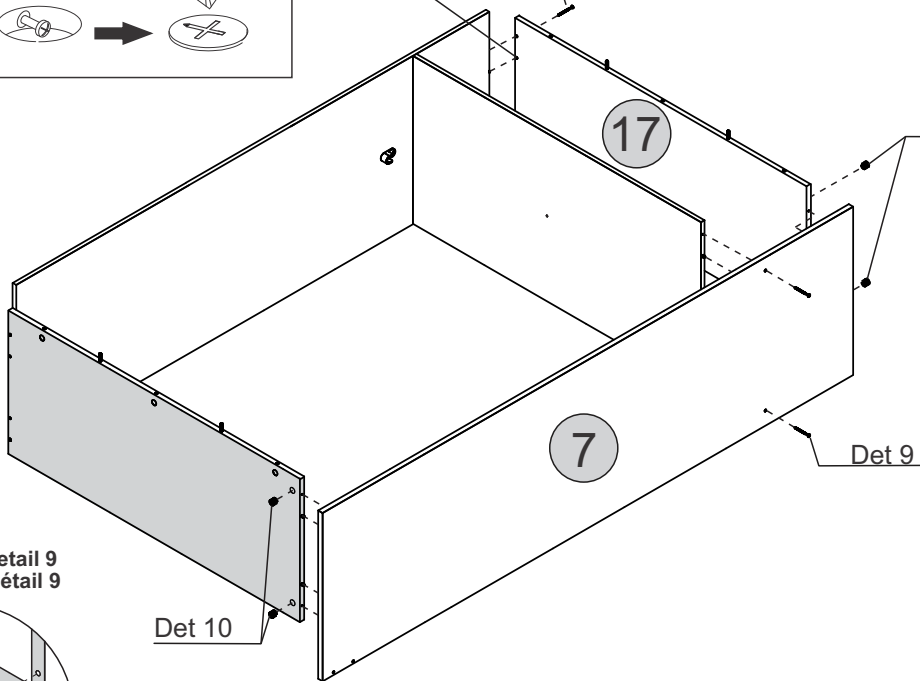

Det 10

Det 9

Det 10

Detalle 8 / Detail 8
Detalhe 8 / Détail 8

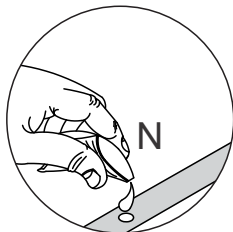

Detalle 9 / Detail 9
Detalhe 9 / Détail 9

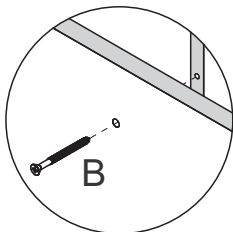

10

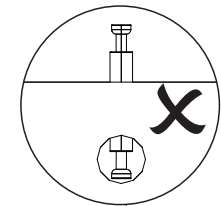
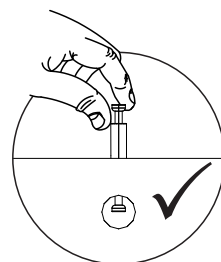
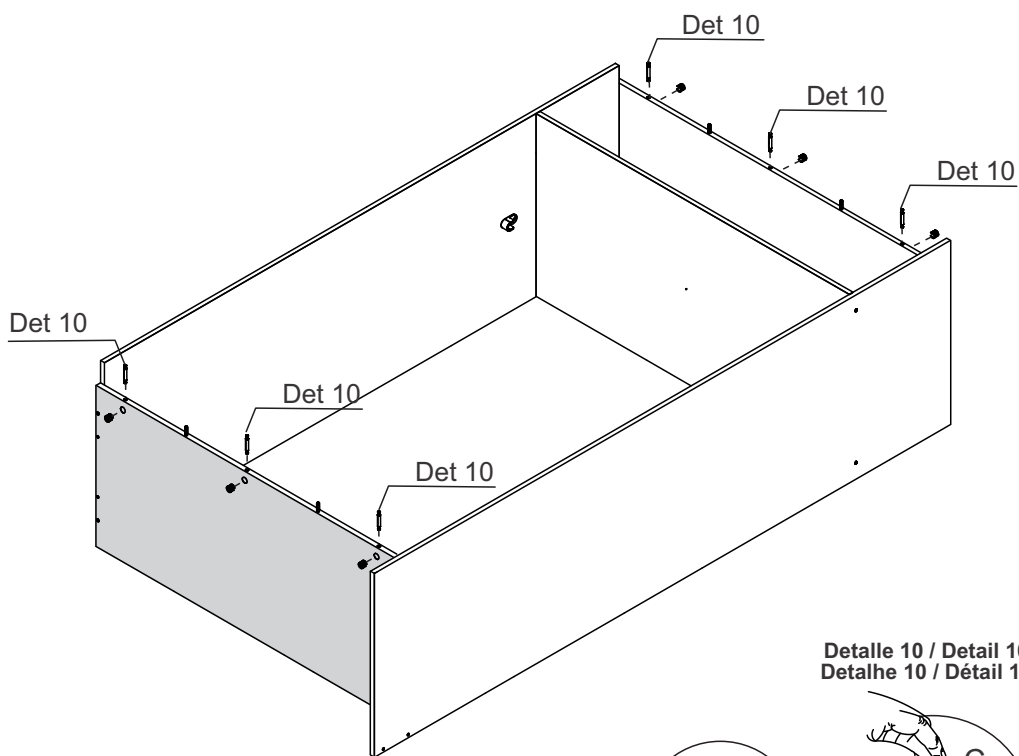

Detalle 10 / Detail 10
Detalhe 10 / Détail 10

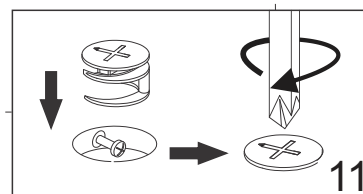
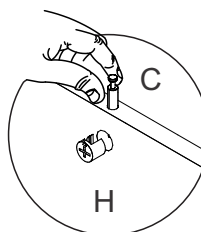
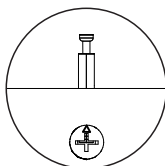

11

11

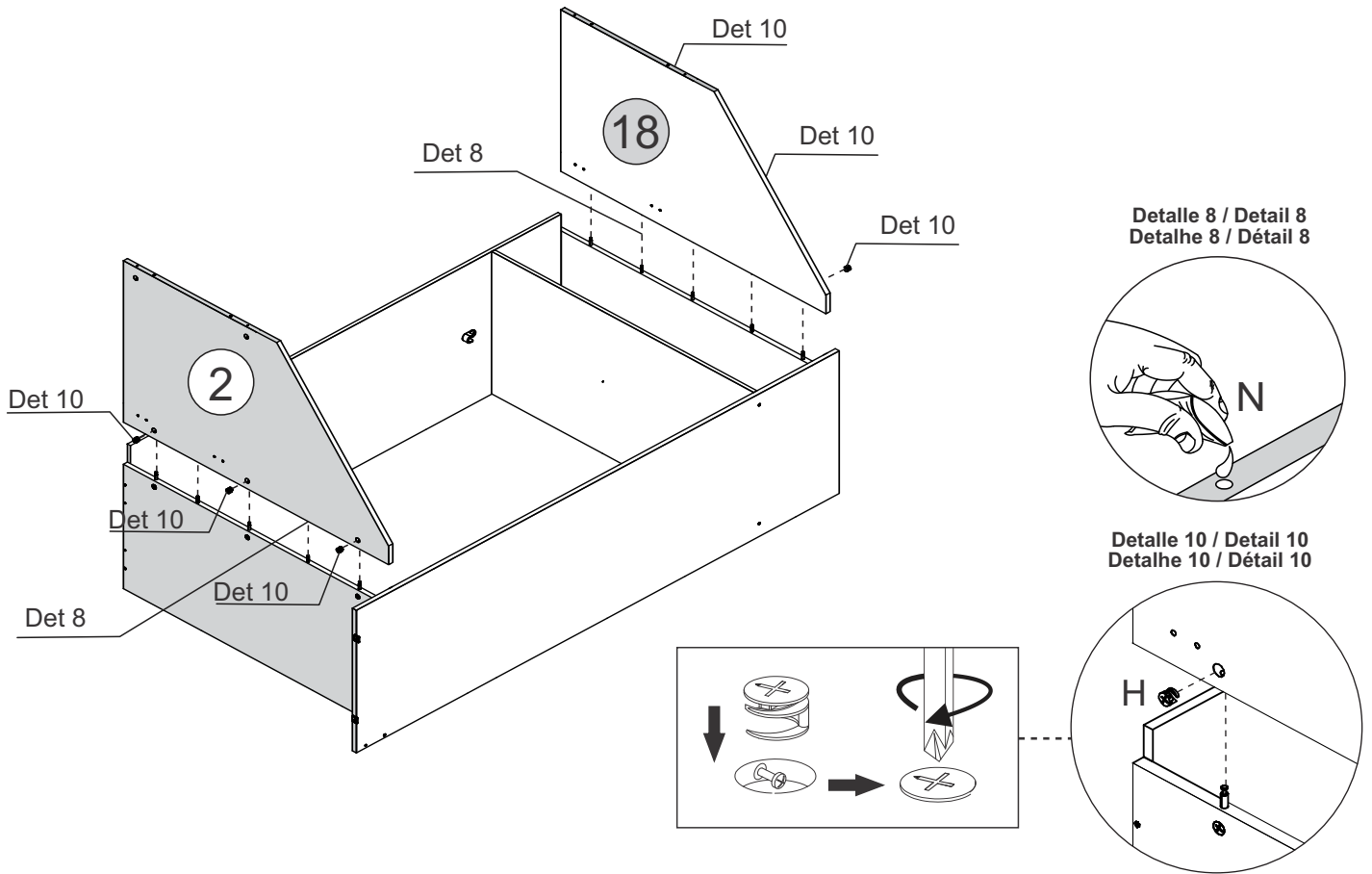

12

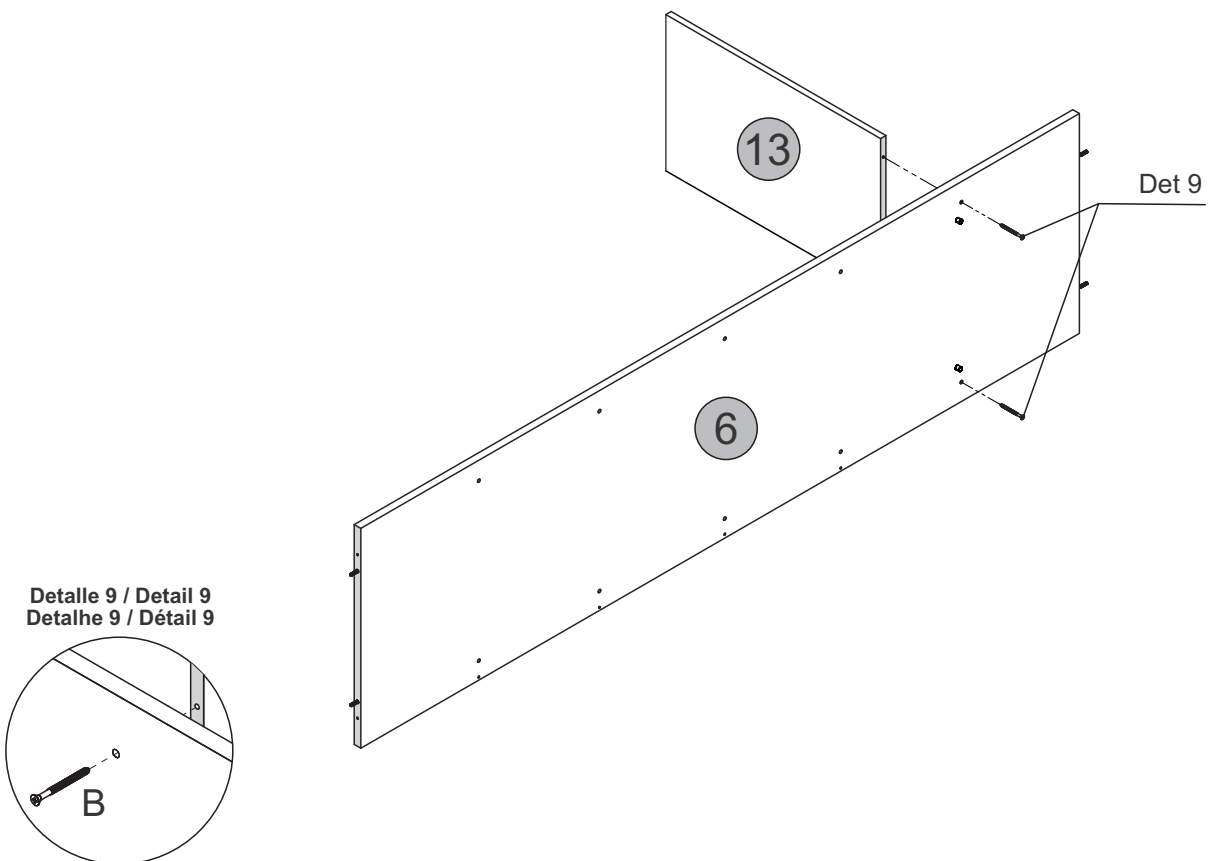

13

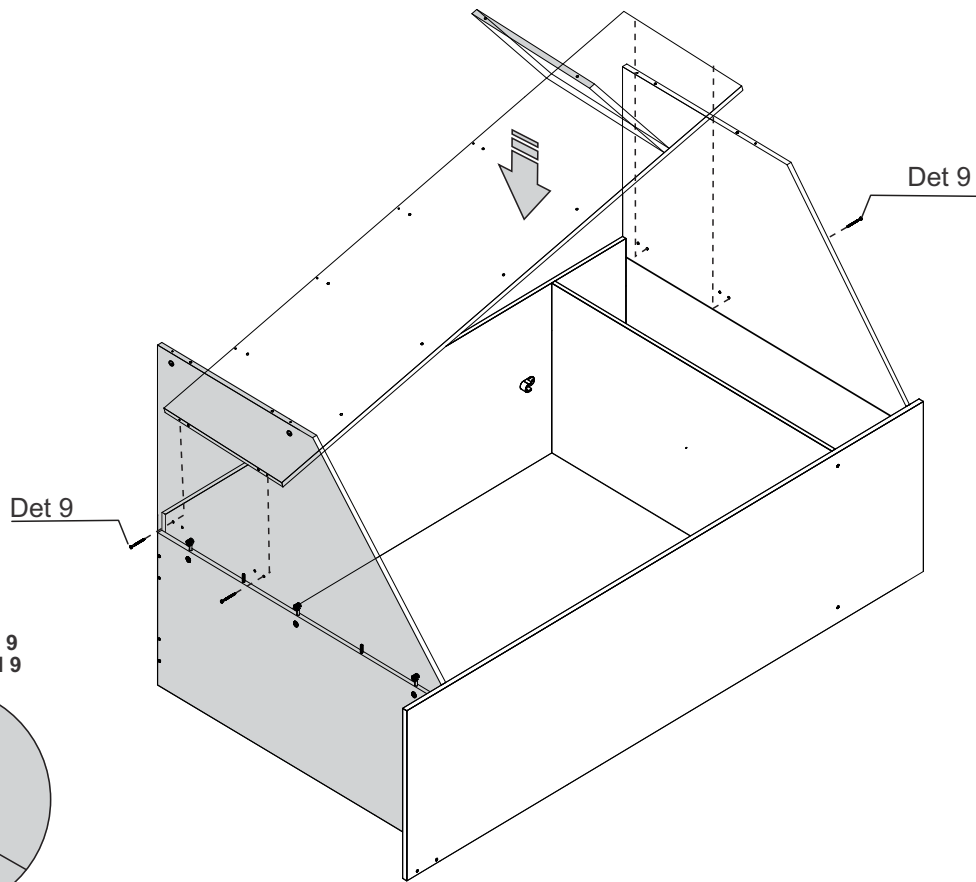

Detalle 9 / Detail 9
Detalhe 9 / Détail 9

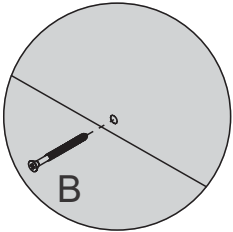

14

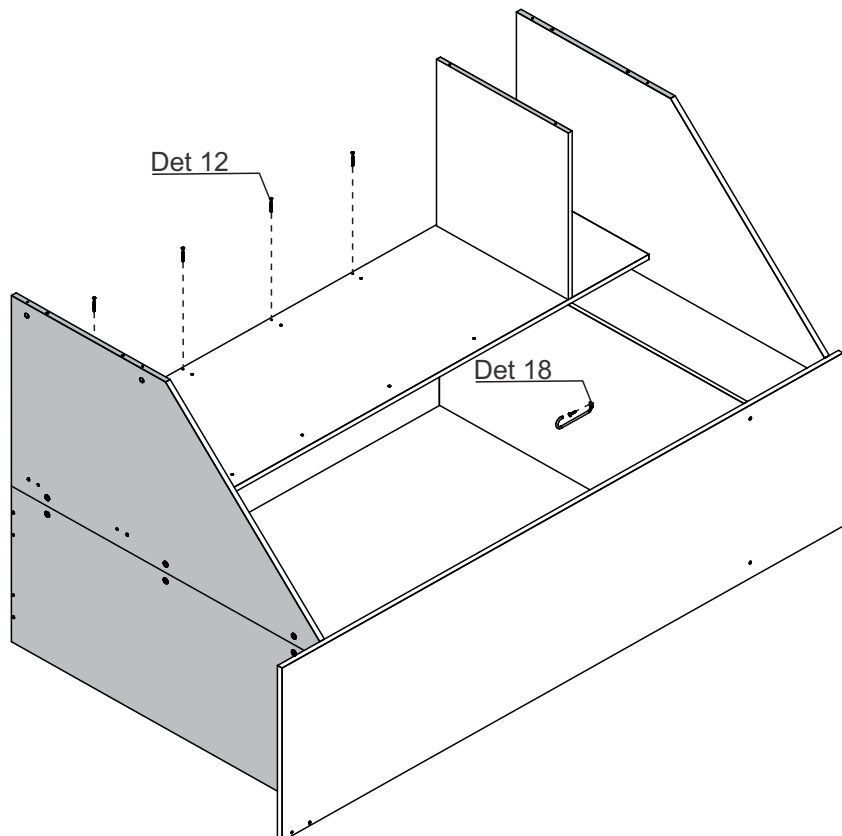

Detalle 12 / Detail 12
Detalhe 12 / Détail 12

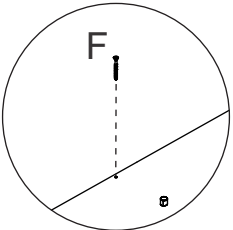

Detalle 18 / Detail 18
Detalhe 18 / Détail 18

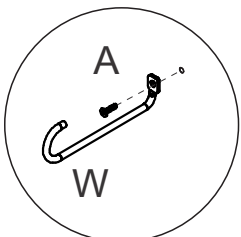

15

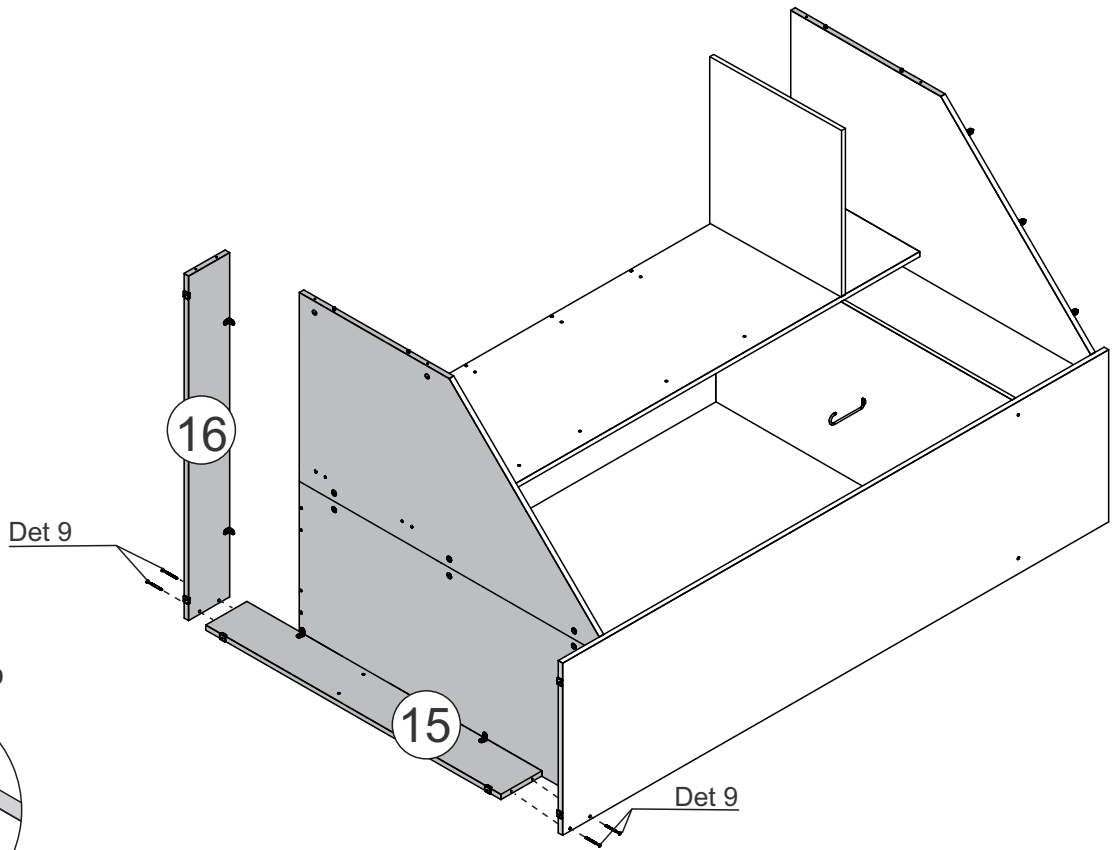

Detalle 9 / Detail 9
Detalhe 9 / Détail 9

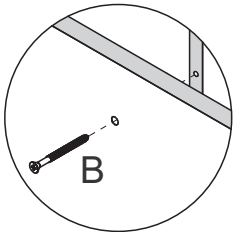

16

Detalle 10 / Detail 10
Detalhe 10 / Détail 10

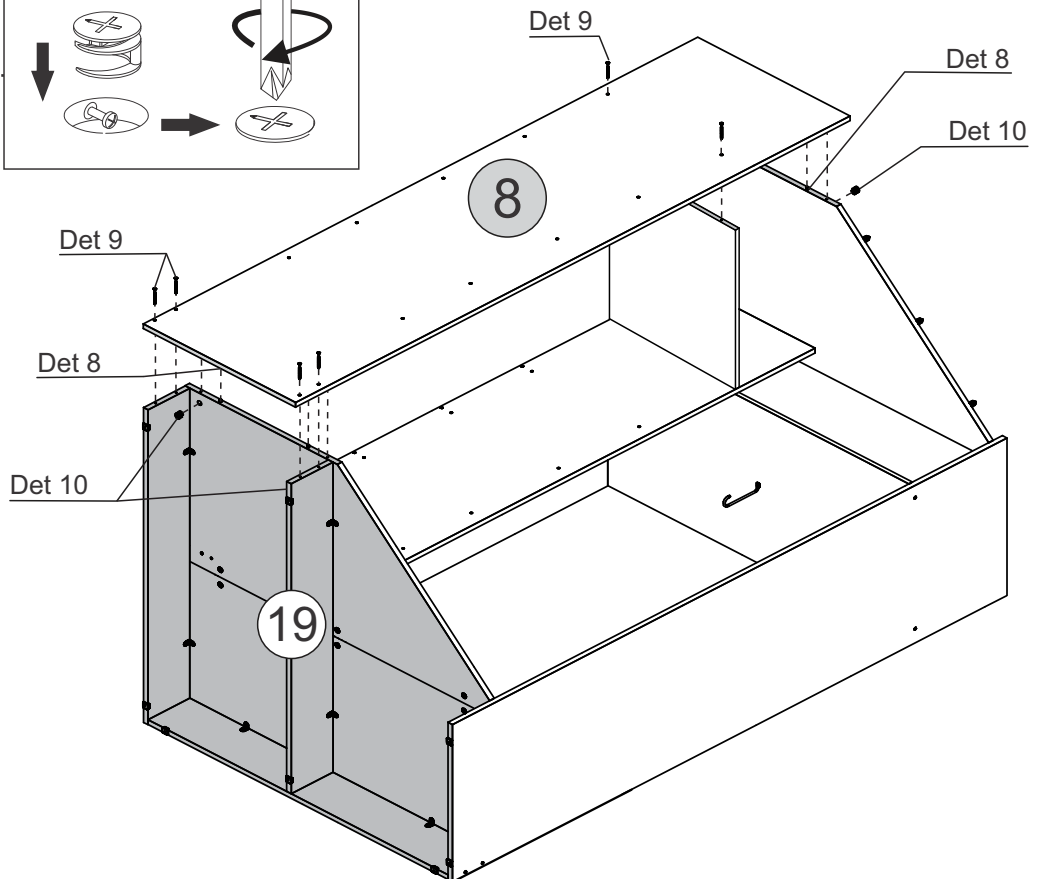
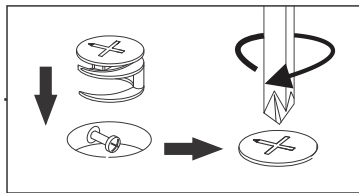
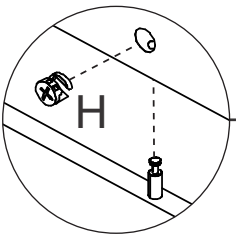

Detalle 8 / Detail 8
Detalhe 8 / Détail 8

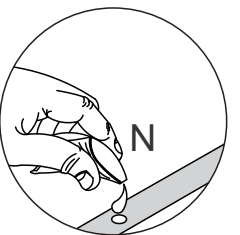

Detalle 9 / Detail 9
Detalhe 9 / Détail 9

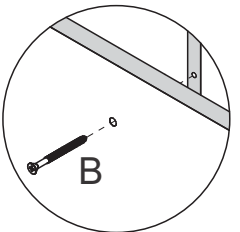

17

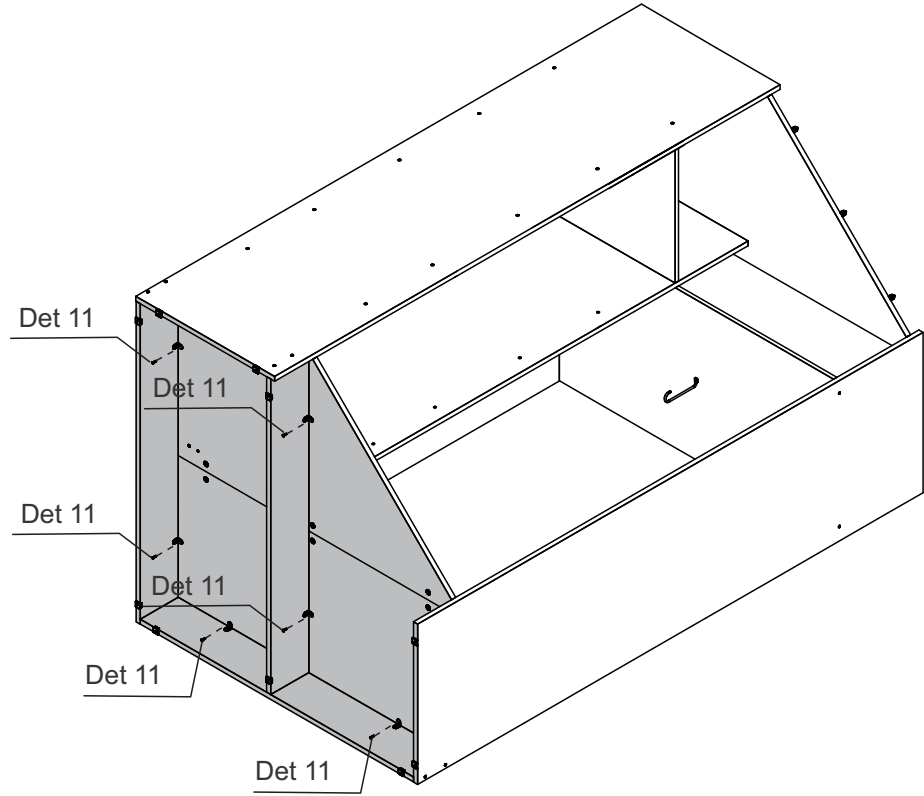

Detalle 11 / Detail 11
Detalhe 11 / Détail 11

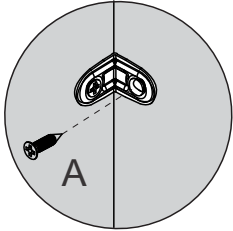

18

Detalle 13 / Detail 13
Detalhe 13 / Détail 13

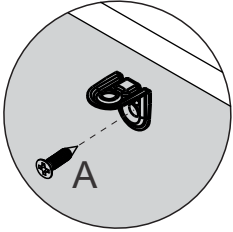

Detalle 17 / Detail 17
Detalhe 17 / Détail 17

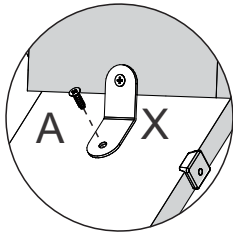

Detalle 14 / Detail 14
Detalhe 14 / Détail 14

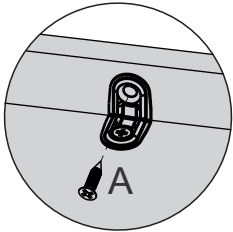

Detalle 15 / Detail 15
Detalhe 15 / Détail 15

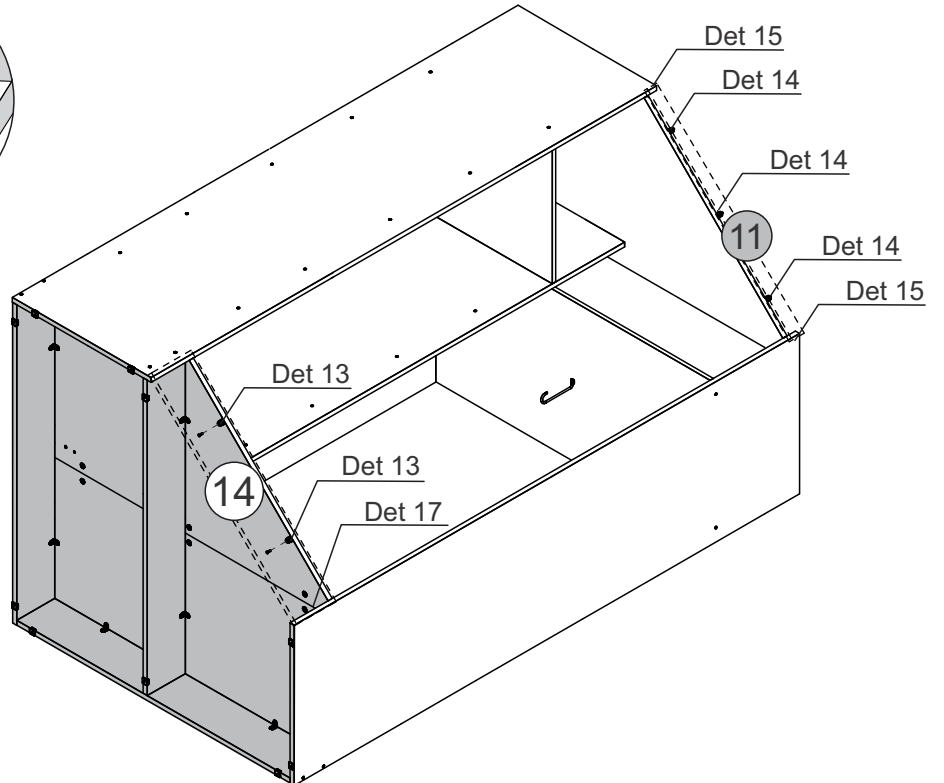
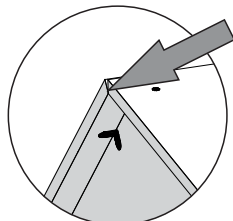

Detalle 9 / Detail 9
 Detalhe 9 / Détail 9

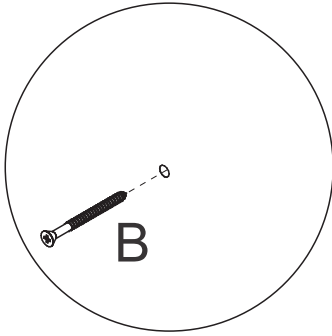

Detalle 23 / Detail 23
 Detalhe 23 / Détail 23

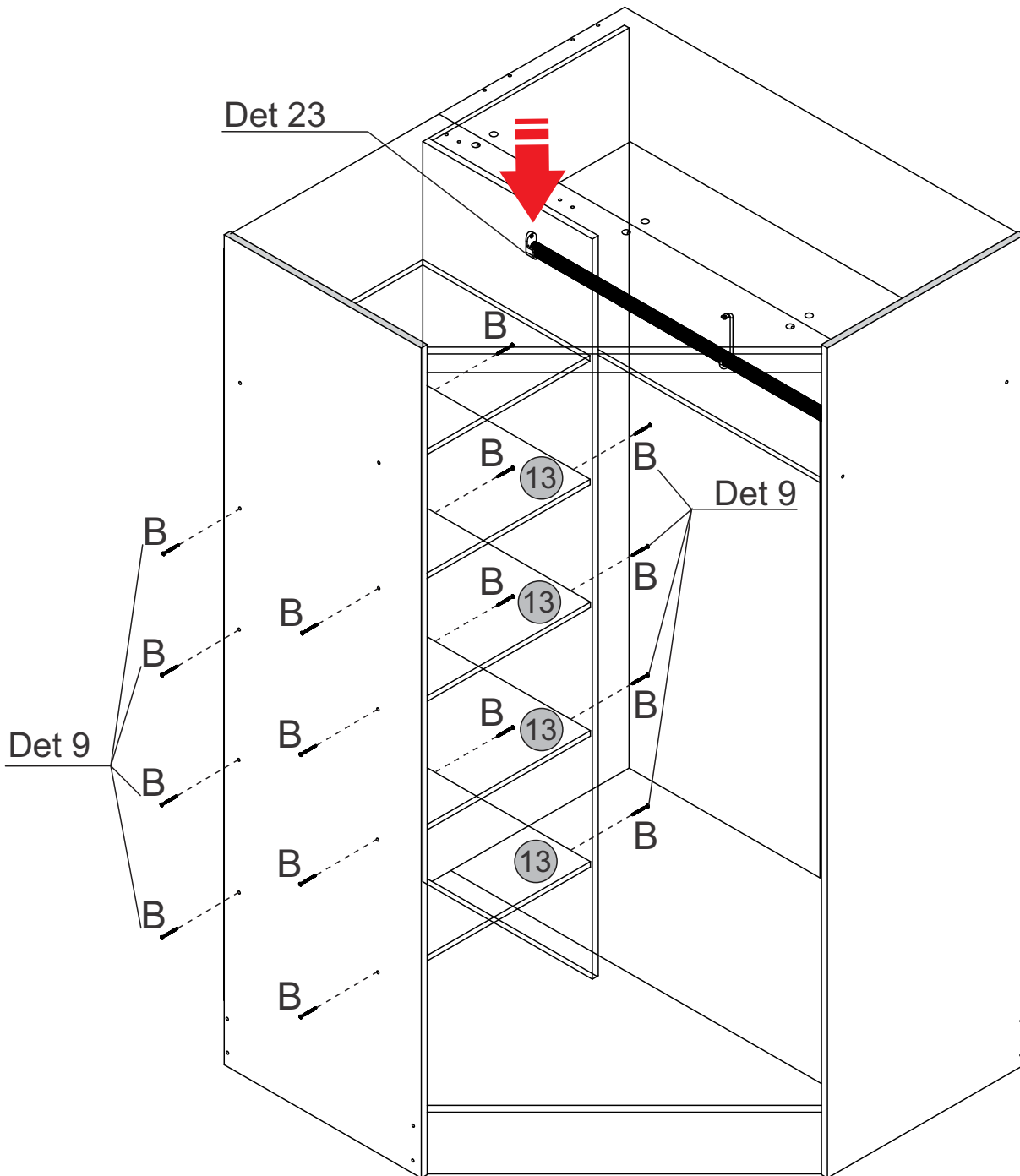
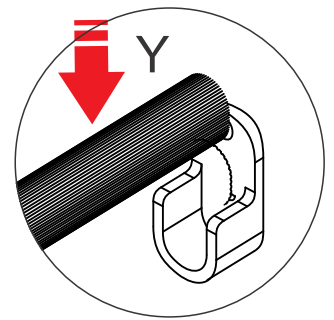

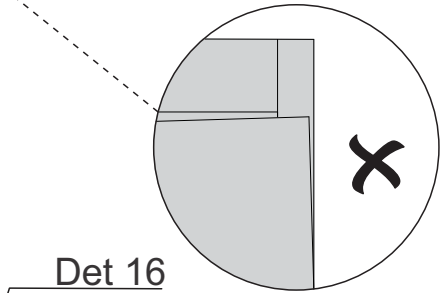
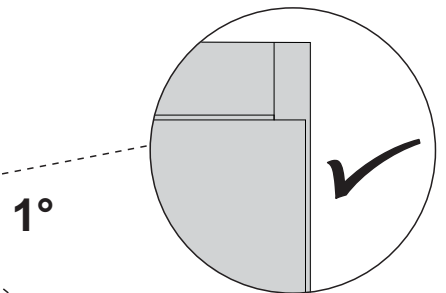
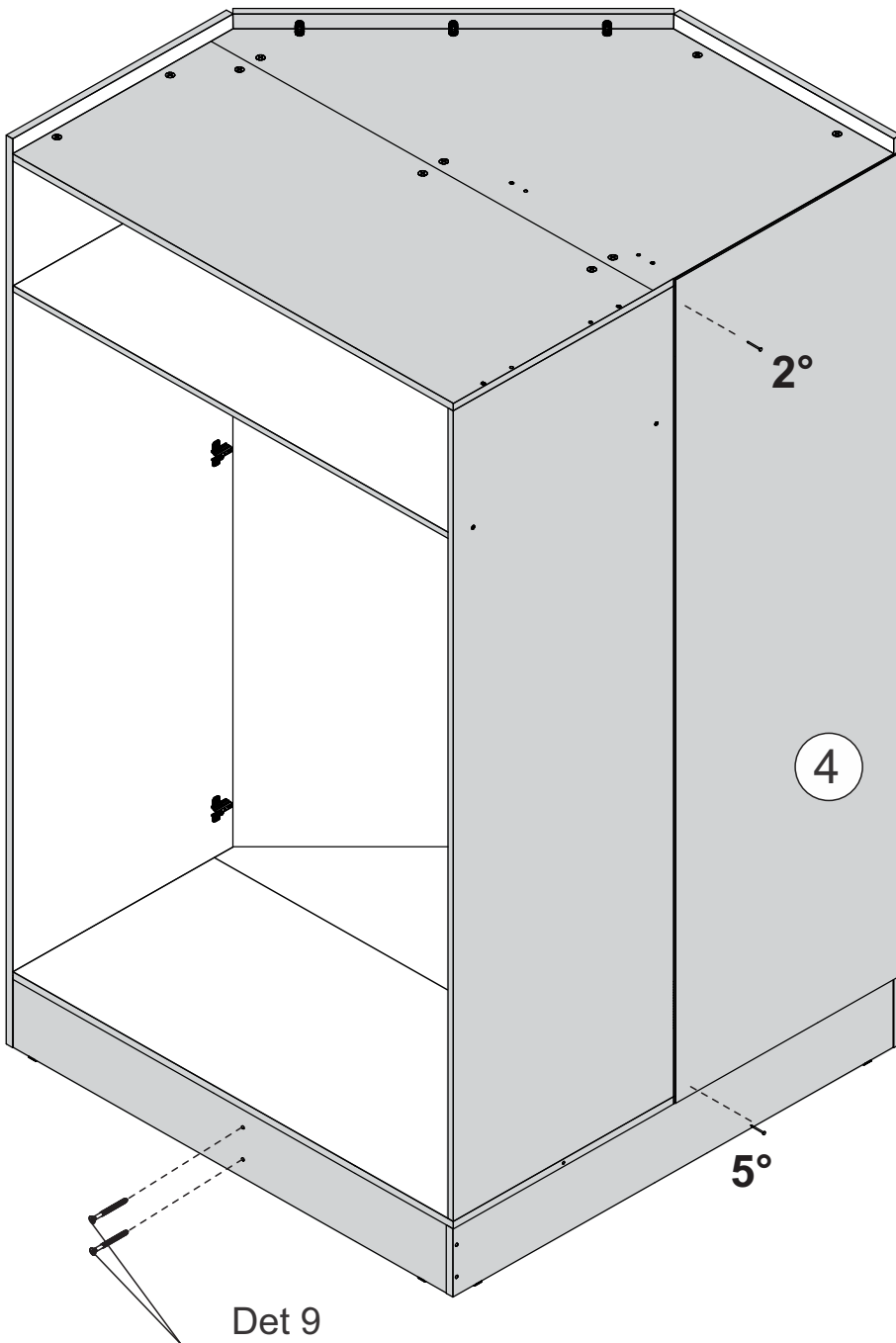
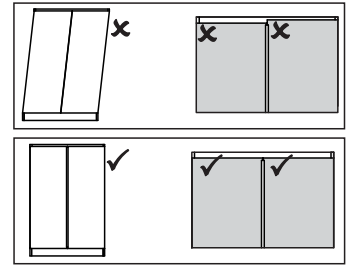

Det 16
3°

Detalle 16 / Detail 16
Detalhe 16 / Détail 16

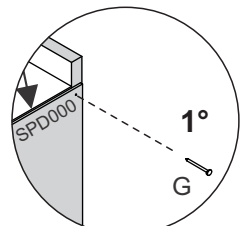

Detalle 9 / Detail 9
Detalhe 9 / Détail 9

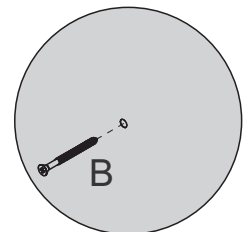

ES: COLOQUE LOS PRIMEROS CLAVOS EN EL ORDEN QUE SE MUESTRA.
 EN: ATTACH THE FIRST NAILS IN THE ORDER SHOWN.
 PT: PRENDA OS PRIMEIROS PREGOS NA ORDEM MOSTRADA.
 FR: ENFONCEZ LES PREMIERS CLOUS DANS L'ORDRE INDIQUÉ.



ES: COLOQUE LOS PRIMEROS 5 CLAVOS, LUEGO INSERTE LA TIRA DEL PANEL TRASERO Y COLOQUE EL OTRO PANEL TRASERO, FIJE LOS OTROS 5 CLAVOS Y TERMINE FIJANDO EL RESTO DE CLAVOS AL PRODUCTO (SIGUIENTE PASO).

EN: ATTACH DE FIRST 5 NAILS, THEN INSERT THE BACK PANEL STRIP AND FIT THE OTHER BACK PANEL, ATTACH THE OTHER 5 NAILS AND FINISH BY ATTACHING THE REST OF THE NAILS TO THE PRODUCT (NEXT STEP).

PT: FIXE OS 5 PRIMEIROS PREGOS, DEPOIS INSIRA A TIRA DO PAINEL TRASEIRO E ENCAIXE O OUTRO PAINEL TRASEIRO, FIXE OS OUTROS 5 PREGOS E FINALIZE FIXANDO O RESTANTE DOS PREGOS NO PRODUTO (PRÓXIMO PASSO).

FR: FIXEZ LES 5 PREMIERS CLOUS, PUIS INSÉREZ LA BANDE DU PANNEAU ARRIÈRE ET AJUSTEZ L'AUTRE PANNEAU ARRIÈRE, FIXEZ LES 5 AUTRES CLOUS ET TERMINEZ EN FIXANT LE RESTE DES CLOUS AU PRODUIT (ÉTAPE SUIVANTE).

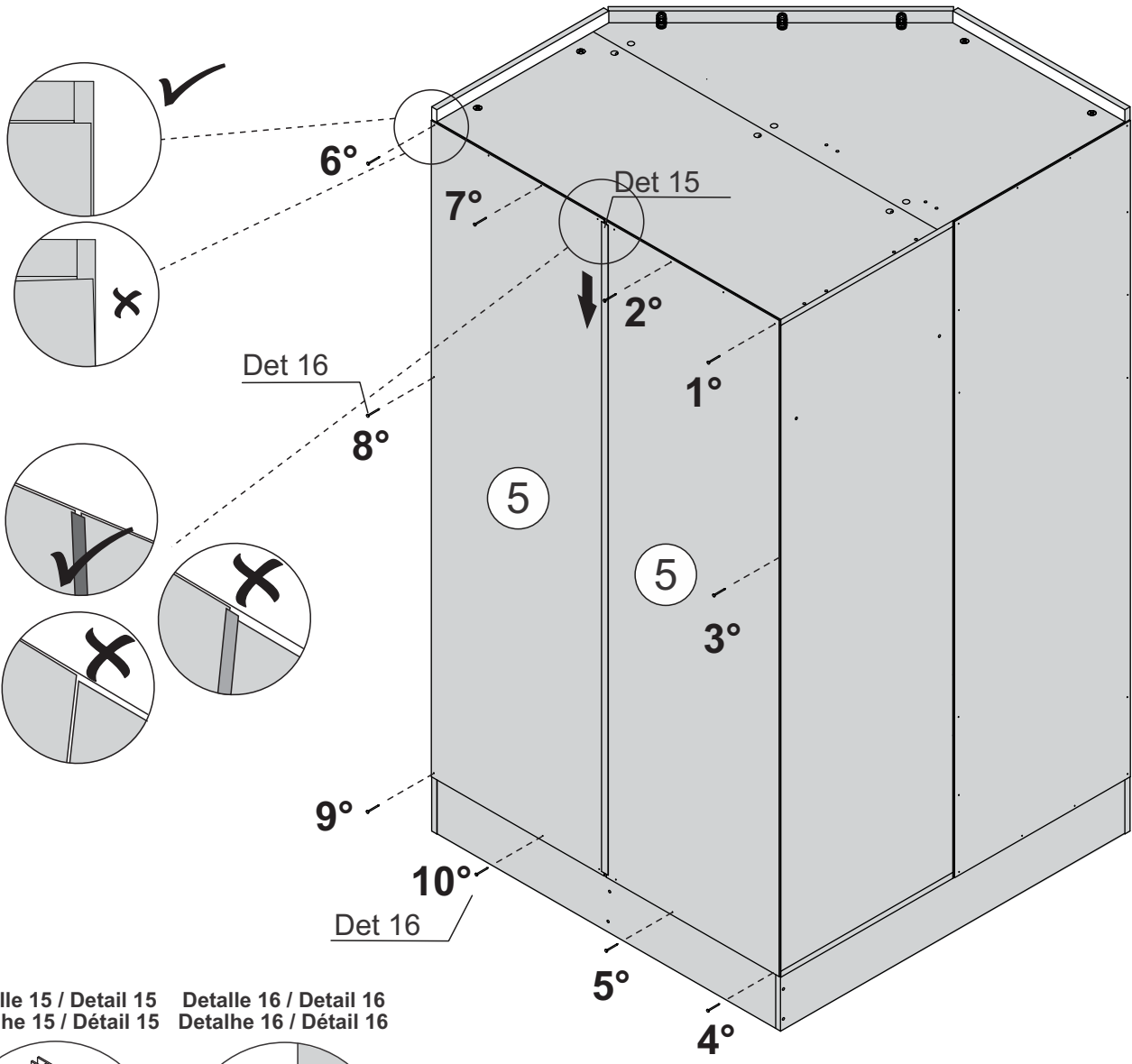
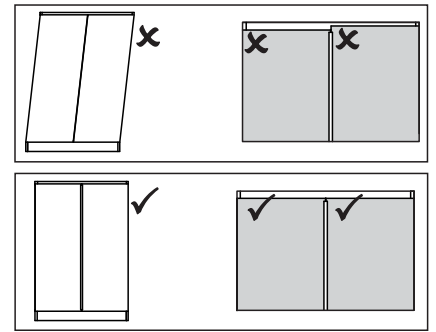

Detalle 15 / Détail 15 Detalle 16 / Détail 16
 Detalhe 15 / Détail 15 Detalhe 16 / Détail 16

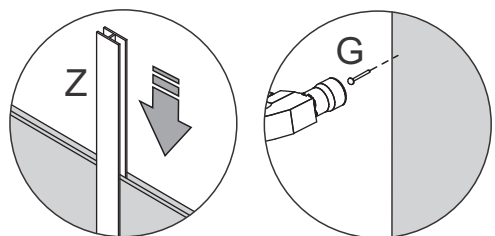

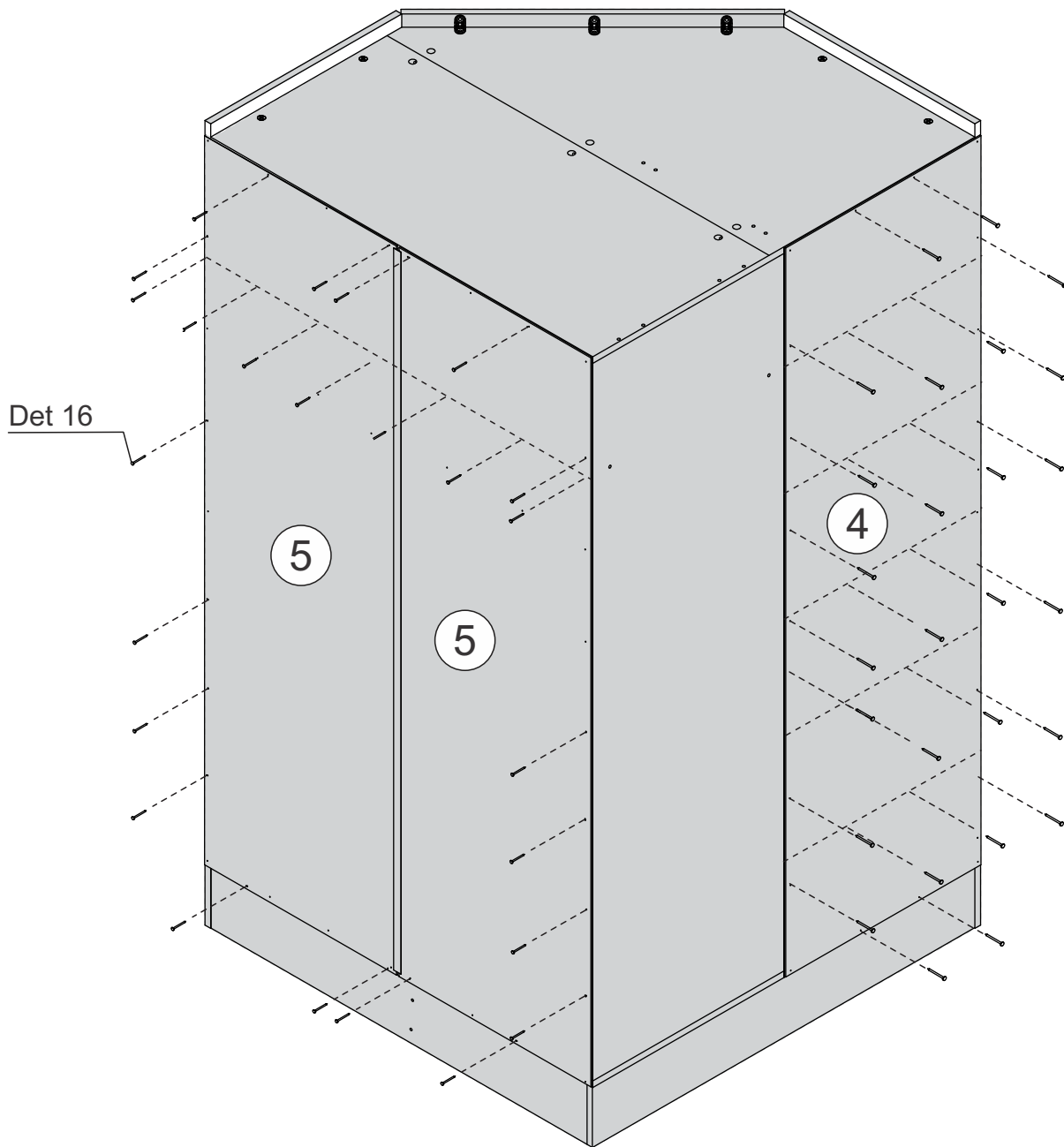

Detalle 16 / Detail 16
 Detalhe 16 / Détail 16

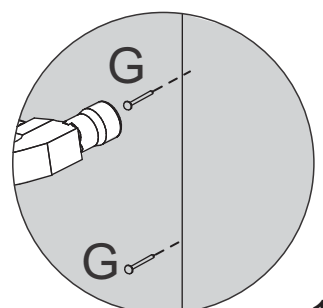

23

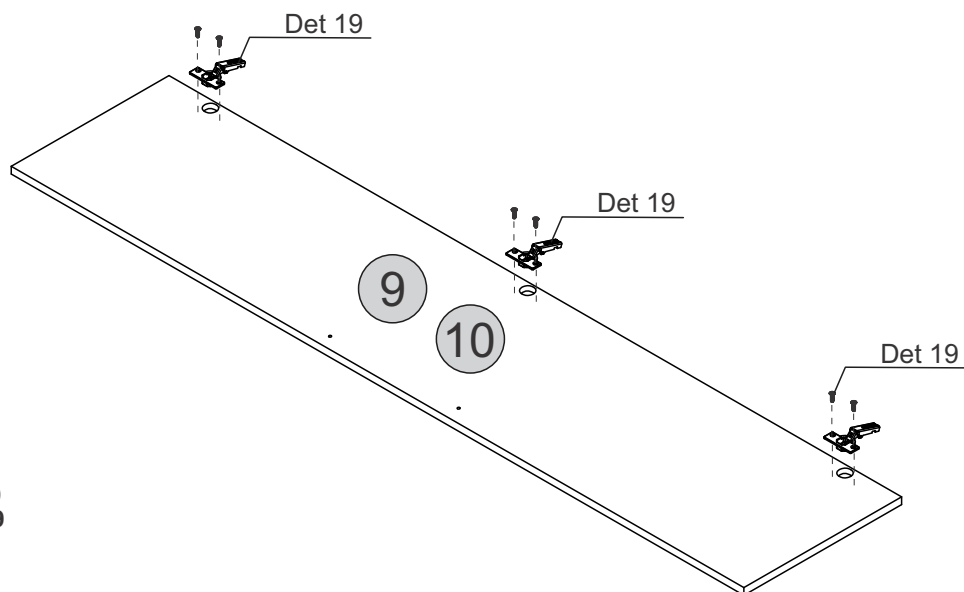

Detalle 19 / Detail 19
Detalhe 19 / Détail 19

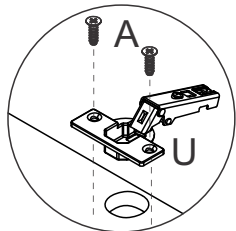

24

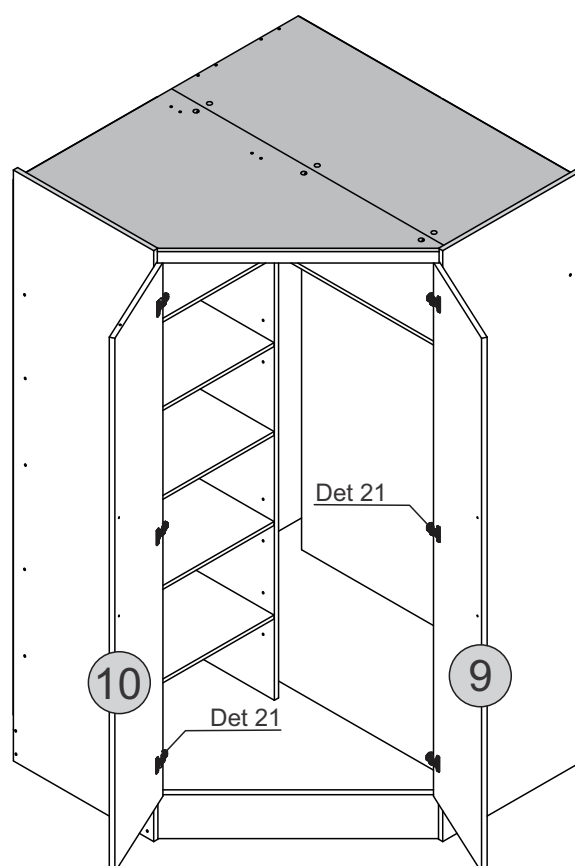

Detalle 21 / Detail 21
Detalhe 21 / Détail 21

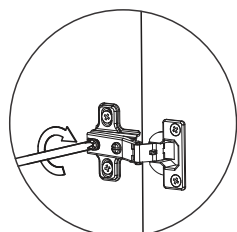
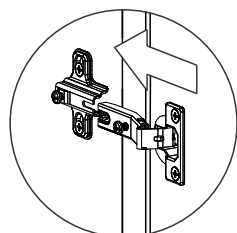

25

Detalle 22 / Detail 22
 Detalhe 22 / Détail 22

Detalle 23 / Detail 23
 Detalhe 23 / Détail 23

Detalle 24 / Detail 24
 Detalhe 24 / Détail 24

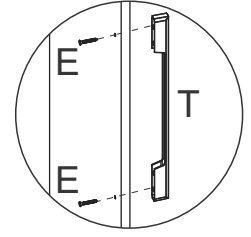
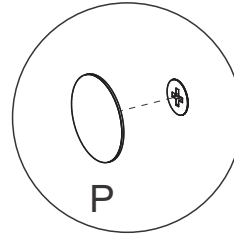
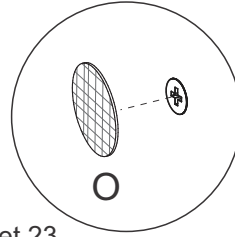
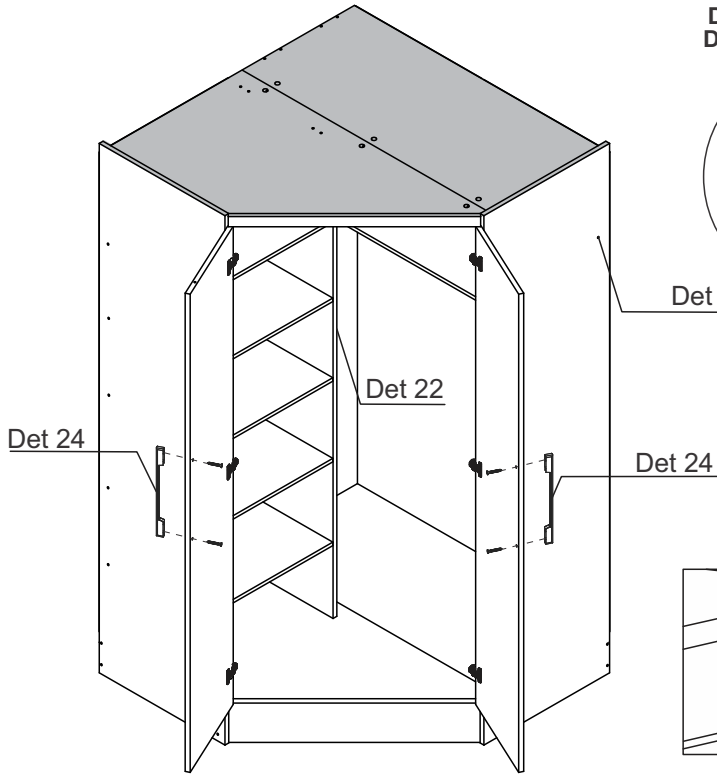

Det 23

Ajustes da Bisagra
Hinge Adjustments
Ajustes da Dobradiça
Ajustements de Charnière

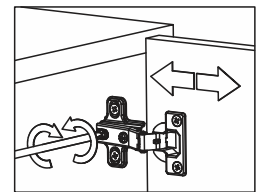
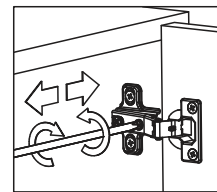
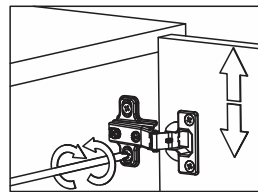

26

Detalle 25 / Detail 25
 Detalhe 25 / Détail 25

