

SKU

N635P466400-N635P466401

DE:Installationsanleitung
UK:Installation Instruction
FR:Instruction d'installation
IT:Istruzioni di installazione
ES: Instrucciones de instalación
NL:Installatie-instructies
SE:Installationsanvisningar
PL: Instrukcje instalacji

Unser Produkt wird Ihnen in 2 Paketen geliefert. Die Lieferzeiten dieser 2 Pakete können abweichen, bitte haben Sie etwas Geduld und vielen Dank für Ihr Verständnis.

Our product will be delivered to you in 2 packages. The delivery times of these 2 packages may differ, please be patient and thank you for your understanding.

Notre produit vous sera livré en 2 colis. Les délais de livraison de ces 2 colis peuvent différer, soyez patient et merci pour votre compréhension.

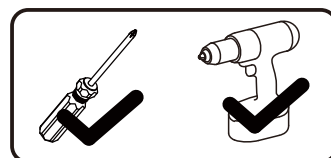
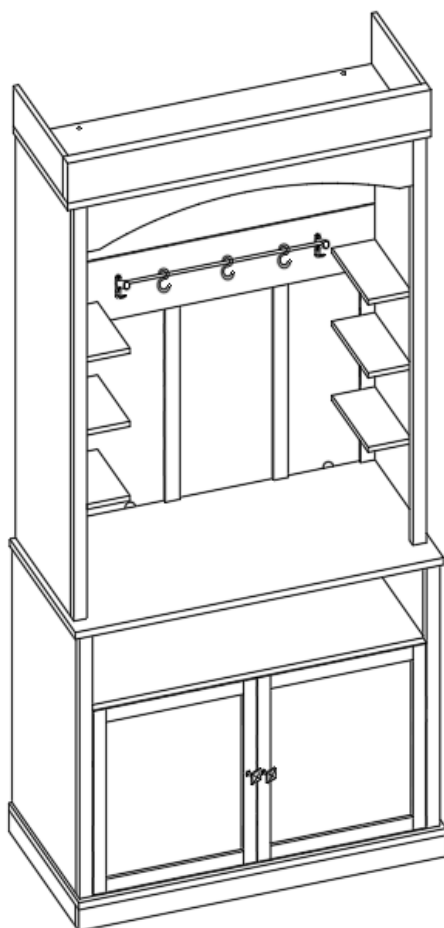

EN_IMPORTANT, RETAIN FOR FUTURE REFERENCE: READ CAREFULLY.

FR_IMPORTANT: A LIRE ATTENTIVEMENT ET À CONSERVER POUR CONSULTATION ULTÉRIEURE.

ES_IMPORTANTE, LEA Y GUARDE PARA FUTURAS REFERENCIAS.

DE_, WICHTIG! SORGFÄLTIG LESEN UND FÜR SPÄTER NACHSCHLAGEN AUFBEWAHREN."

IT_IMPORTANTE! CONSERVARE IL PRESENTE MANUALE PER FUTURO RIFERIMENTO E LEGGERLO ATTENTAMENTE.



DE

Warnung: Die maximale Belastbarkeit dieses Möbels beträgt: 70 kg, bitte nicht überlasten!

EN

Warning: The maximum load-bearing capacity of this furniture is: 70 kg, please do not overload!

FR

Avertissement : La capacité de charge maximale de ce meuble est de : 70 kg, merci de ne pas surcharger !

IT

Attenzione: la capacità di carico massima di questo mobile è: 70 kg, non sovraccaricare!

ES

Advertencia: La capacidad máxima de carga de este mueble es: 70 kg, ¡no lo sobrecargue!



[DE]

Warnung: Lesen Sie diese Anleitung vor dem Zusammenbau bitte vollständig durch. Überprüfen Sie, ob Sie alle auf den Seiten aufgeführten Komponenten und Werkzeuge haben. Bewahren Sie die Anleitung zum späteren Nachschlagen auf. Teile des Zusammenbaus lassen sich mit 2 Personen leichter durchführen. Suchen Sie bei Bedarf professionelle Hilfe.

Warnung: Legen Sie alle Teile auf eine ebene Fläche. Legen Sie eine weiche Decke oder Ähnliches darunter, um sie vor Kratzern oder Flecken zu schützen. Vermeiden Sie es, Komponenten über den Boden zu ziehen oder zu schieben.

Warnung: Überprüfen Sie regelmäßig alle Beschläge und Befestigungen, um sicherzustellen, dass sie sicher sind und um Unfälle zu vermeiden. Wenn Teile fehlen, kaputt, beschädigt oder abgenutzt sind, verwenden Sie das Produkt nicht weiter, bis es mit vom Hersteller autorisierten Teilen repariert wurde.

Warnung: Lassen Sie Kinder nicht auf die Möbel klettern, da dies zum Umkippen und zu schweren Verletzungen führen kann. Bauen Sie die Möbel außerhalb der Reichweite von Kindern zusammen.

Warnung: Stellen Sie die Möbel nicht in die Nähe von Feuerquellen oder heißen Gegenständen, um Brandgefahr zu vermeiden.

Warnung: Reinigen Sie die Möbel mit einem feuchten Tuch oder Alkohol. Verwenden Sie keine Reinigungsmittel mit ätzenden Chemikalien.

Warnung: Dieses Produkt ist mit einer Kippschutzvorrichtung ausgestattet. Bitte installieren Sie diese Vorrichtung unbedingt, um unnötige Verletzungen durch Umkippen zu vermeiden.

[EN]

Warning: Please read these instructions fully before starting assembly. Check you have all the components and tools listed on pages. Keep the instructions for later reference. Parts of the assembly will be easier with 2 people. Seek professional assistance if necessary.

Warning: Please place all parts on a flat surface. Place a soft blanket or similar underneath to protect against scratches or stains. Avoid dragging or sliding components across the floor.

Warning: Regularly check all fittings and fastenings to ensure they are secure and to prevent accidents. If any parts are missing, broken, damaged, or worn, discontinue use of the product until repairs have been made using factory authorized parts.

Warning: Do not allow children to climb on the furniture as this may result in tipping and serious personal injury. Assemble the furniture away from the reach of children.

Warning: Do not place furniture close to fire sources or high-temperature objects to avoid the risk of fire. Do not place furniture in damp environments to prevent material damage.

Warning: Clean furniture with a damp cloth or alcohol, avoid using cleaning agents containing corrosive chemicals.

Warning: This product is equipped with an anti-tilt device. Please be sure to install this device to prevent unnecessary injuries caused by tipping.

[FR]

Avertissement : Veuillez lire attentivement ces instructions avant de commencer l'assemblage. Vérifiez que vous disposez de tous les composants et outils répertoriés sur les pages. Conservez les instructions pour référence ultérieure. Certaines parties de l'assemblage seront plus faciles à 2 personnes. Demandez l'aide d'un professionnel si nécessaire.

Avertissement : Veuillez placer toutes les pièces sur une surface plane. Placez une couverture douce ou similaire en dessous pour les protéger des rayures ou des taches. Évitez de faire glisser les composants sur le sol.

Avertissement : Vérifiez régulièrement tous les raccords et fixations pour vous assurer qu'ils sont bien fixés et pour éviter les accidents. Si des pièces manquent, sont cassées, endommagées ou usées, cessez d'utiliser le produit jusqu'à ce que des réparations aient été effectuées à l'aide de pièces autorisées par l'usine.

Avertissement : Ne laissez pas les enfants grimper sur les meubles car cela pourrait entraîner un basculement et des blessures graves. Assemblez les meubles hors de portée des enfants.

Avertissement : Ne placez pas les meubles à proximité de sources de feu ou d'objets à haute température pour éviter tout risque d'incendie.

Avertissement : Nettoyez les meubles avec un chiffon humide ou de l'alcool, évitez d'utiliser des produits de nettoyage contenant des produits chimiques corrosifs.

Avertissement : Ce produit est équipé d'un dispositif anti-basculement. Assurez-vous d'installer ce dispositif pour éviter les blessures inutiles causées par un basculement.



[IT]

Attenzione: leggere attentamente le istruzioni prima di iniziare il montaggio. Verificare di avere tutti i componenti e gli strumenti elencati nelle pagine.

Attenzione: posizionare tutte le parti su una superficie piana. Posizionare una coperta morbida o simile sotto per proteggere da graffi o macchie. Evitare di trascinare o far scivolare i componenti sul pavimento.

Attenzione: controllare regolarmente tutti i raccordi e i dispositivi di fissaggio per assicurarsi che siano sicuri e per prevenire incidenti. Se alcune parti sono mancanti, rotte, danneggiate o usurate, interrompere l'uso del prodotto fino a quando non siano state eseguite le riparazioni utilizzando parti autorizzate dalla fabbrica.

Attenzione: non consentire ai bambini di arrampicarsi sui mobili poiché ciò potrebbe causare ribaltamenti e gravi lesioni personali. Montare i mobili lontano dalla portata dei bambini.

Attenzione: non posizionare i mobili vicino a fonti di fuoco o oggetti ad alta temperatura per evitare il rischio di incendio.

Attenzione: pulire i mobili con un panno umido o alcol, evitare di utilizzare detergenti contenenti sostanze chimiche corrosive.

[ES]

Advertencia: Lea las instrucciones completamente antes de comenzar el montaje. Compruebe que tiene todos los componentes y herramientas que se enumeran en las páginas.

Advertencia: Coloque todas las piezas sobre una superficie plana. Coloque una manta suave o algo similar debajo para protegerlas de rayones o manchas. Evite arrastrar o deslizar los componentes por el piso.

Advertencia: Verifique regularmente todos los accesorios y fijaciones para asegurarse de que estén seguros y evitar accidentes. Si falta alguna pieza, está rota, dañada o desgastada, deje de usar el producto hasta que se hayan realizado las reparaciones con piezas autorizadas de fábrica.

Advertencia: No permita que los niños se suban a los muebles, ya que esto puede provocar que se vuelquen y lesiones personales graves. Monte los muebles fuera del alcance de los niños.

Advertencia: No coloque los muebles cerca de fuentes de fuego u objetos de alta temperatura para evitar el riesgo de incendio.

Advertencia: Limpie los muebles con un paño húmedo o alcohol, evite usar agentes de limpieza que contengan químicos corrosivos.

Importeur	Decobus Handel GmbH		
Adresse	Innungsstraße 9, 21244 Buchholz, Deutschland		
Email/URL	https://www.decobusgroup.de		
Hersteller	Shine Home Trade Co., Limited		
Adresse	Rm12,19/F, Ho King Comm Ctr, 2-16 Fayuen St, Mongkok Kln Hong Kong		
Email/URL	eileen@fzhollyroom.com		
Partienummer	C979SHI20260202TG		
Hergestellt in	CHINA		
<table border="1"><tr><td>EC</td><td>REP</td></tr></table>	EC	REP	Decobus Handel GmbH Innungsstraße 9, 21244 Buchholz, Deutschland https://www.decobusgroup.de
EC	REP		

EN

Dear customer,

Thank you for purchasing this product. So that your appliance serves you well, please read all the instructions in this user's manual. If you have any questions, please contact our customer care center.

FR

Cher client,

Nous vous remercions d'avoir acheté ce produit. Afin que vous puissiez profiter pleinement de votre appareil, veuillez lire toutes les instructions de ce manuel d'utilisation. Si vous avez la moindre question, veuillez contacter notre centre d'assistance à la clientèle.

DE

Sehr geehrter Kunde,

Vielen Dank, dass Sie dieses Produkt erworben haben. Damit Ihr Gerät Ihnen gute Dienste leistet, lesen Sie bitte alle Hinweise in diesem Benutzerhandbuch. Wenn Sie Fragen haben, wenden Sie sich bitte an unser Kundendienstzentrum.

ES

Queridos clientes,

Gracias por comprar este producto. Para que su electrodoméstico le sirva mejor, lea todas las instrucciones de este manual del usuario. Si tiene alguna pregunta, comuníquese con nuestro Centro de Atención al Cliente.

IT

Caro Cliente,

Grazie per aver acquistato questo prodotto. Per servirti meglio con questo apparecchio ti prego di leggere tutte le istruzioni in presente manuale utente. In caso di dubbio, si prega di contattare il nostro centro assistenza clienti.

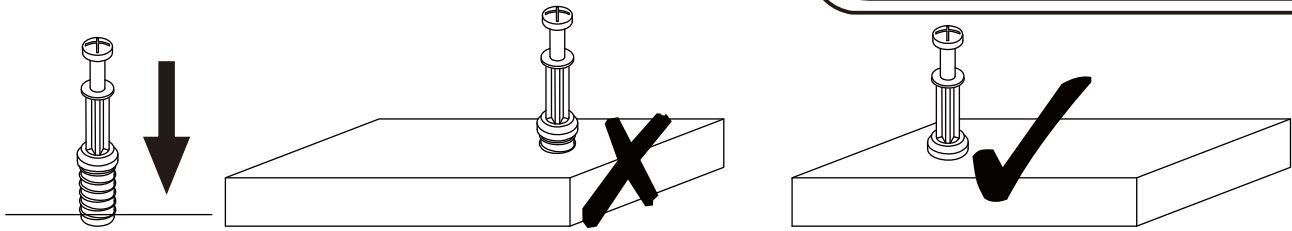

EN_QUICKFIT: Tighten quickfit until shoulder is flush with panel. Do not overtighten or undertighten.

FR_RACCORD RAPIDE: Faites serrer le raccord rapide jusqu'à ce que l'épaulement soit parfaitement encastré dans le panneau. Il ne faut ni trop serrer ni insuffisamment serrer.

ES_QUICKFIT: Apriete quickfit hasta que el hombro se descargue con el panel. NO lo sobreapriete ni lo apriete poco.

DE_QUICKFIT: Ziehen Sie den Quickfit fest, bis die Schulter mit der Platte bündig ist. Bitte nicht zu fest oder zu schwach anziehen.

IT_MONTAGGIO RAPIDO: Stringere il montaggio rapido fino a quando la spalla è a filo con il pannello, non stringere troppo o troppo poco.

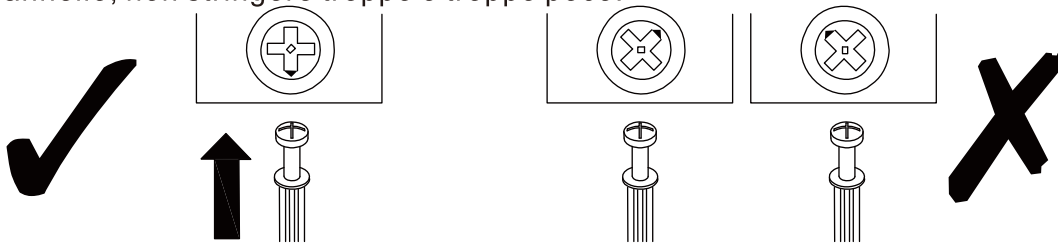

EN_CAM LOCK: When fitting cam lock, ensure starting position is correct before you insert connecting quickfit.

FR_SERRURE BATTEUSE: Avant d'insérer la serrure batteuse, veillez à la bonne orientation avant d'insérer le raccord rapide.

ES_CIERRE DE LA CÁMARA: Cuando instale el cierre de la cámara, asegúrese de que la posición de inicio es correcta antes de que inserte el quickfit conector.

DE_CAM-LOCK: Achten Sie bei der Montage des Cam-Locks auf die richtige Ausgangsposition, bevor Sie den Quickfit einsetzen.

IT_BLOCCAGGIO A CAMMA: Quando si monta il bloccaggio a camma, assicurarsi che la posizione iniziale sia corretta prima di inserire il montaggio rapido di collegamento.

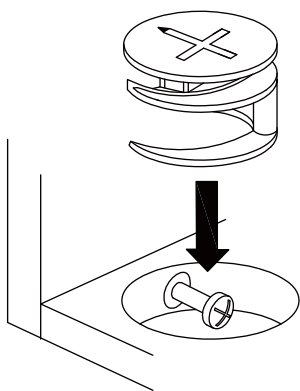

EN_Quickfit head should be in the centre of the cam lock when the two panels are joined.

Cam lock should be inserted before quickfit.

FR_Lorsque les deux panneaux sont assemblés, la tête du raccord rapide doit reposer au centre de la serrure batteuse. Il faut insérer la serrure batteuse avant le raccord rapide.

ES_El cabezal del quickfit debe estar en el centro del cierre de la cámara cuando se unan los dos paneles.

Se debe insertar el cierre de la cámara antes que el quickfit.

DE_Der Quickfit-Kopf sollte sich in der Mitte des Cam-Locks befinden, wenn die beiden Platten zusammengefügt sind.

Der Cam-Lock sollte vor dem Quickfit eingesetzt werden.

IT_La testa del montaggio rapido deve trovarsi al centro del bloccaggio a camma quando i due pannelli sono uniti.

Il Bloccaggio a Camma deve essere inserito prima del montaggio rapido.

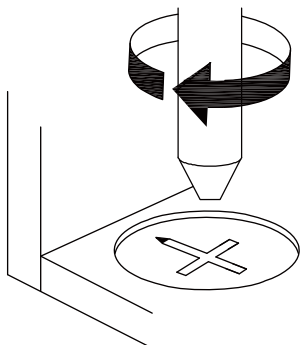

EN_Turn cam lock clockwise to tighten.



FR_Faites tourner la serrure batteuse dans le sens des aiguilles d'une montre pour la resserrer.

ES_Gire el cierre de la cámara en sentido horario para apretarlo.

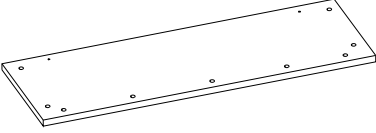
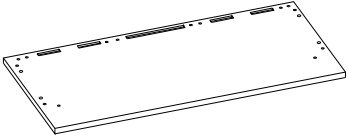
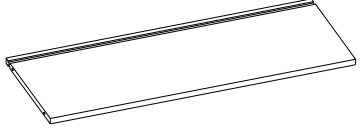
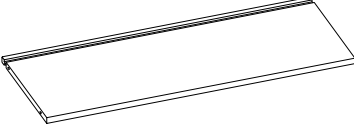
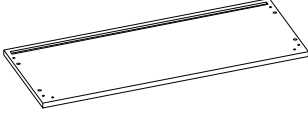
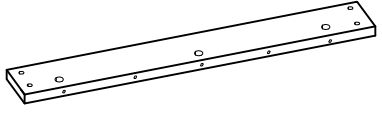
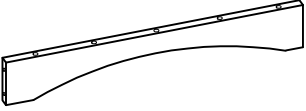
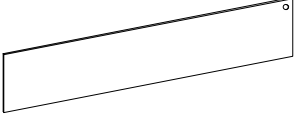
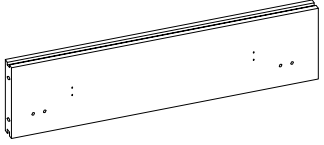

DE_Drehen Sie den Cam-Lock im Uhrzeigersinn, um ihn festzuziehen.

IT_Ruotare il bloccaggio a camma in senso orario per stringere.

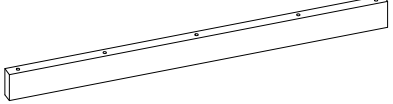
SKU N635P466400

					
①	1pc	②	1pc	③	1pc
					
④	1pc	⑤	1pc	⑮	1pc
					
⑰	1pc	⑱	1pc	⑲	1pc
					
⑳	1pc	㉓	2pcs	㉕	1pc

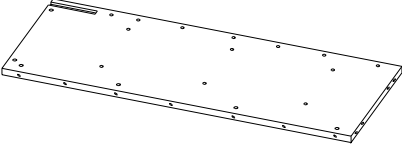
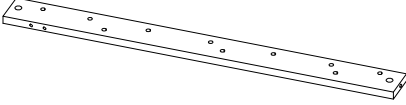
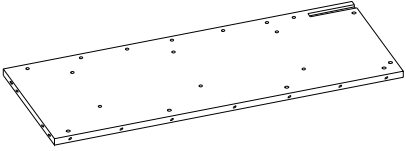
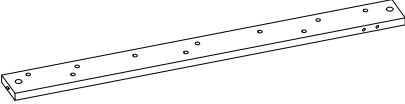
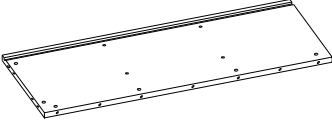
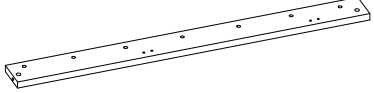
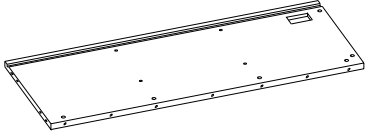
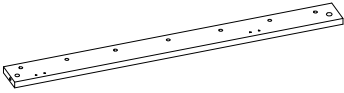
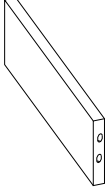
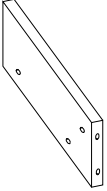

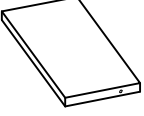
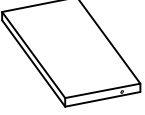
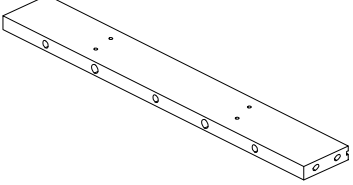
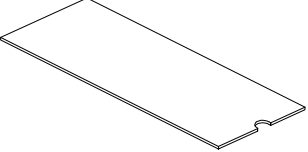
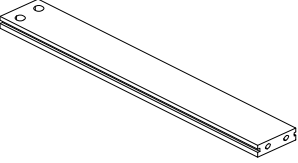
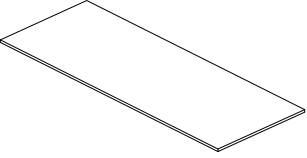



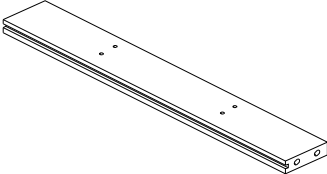
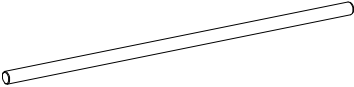
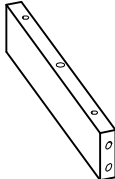
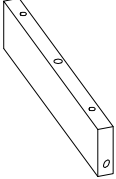
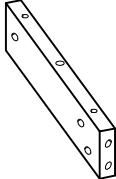
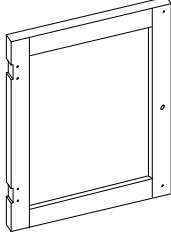
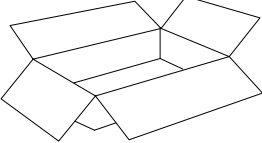

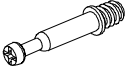

SKU N635P466401

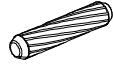
					
⑥	1pc	⑦	1pc	⑧	1pc
					
⑨	1pc	⑩	1pc	⑪	1pc
					
⑫	1pc	⑬	1pc	⑭	1pc
					
⑯	1pc	⑳	1pc	㉑	2pcs
					
㉒	1pc	㉓	2pcs	㉔	1pc
					
㉕	2pcs	㉖	2pcs	㉗	1pc

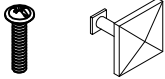
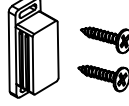
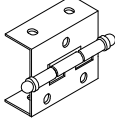
SKU N635P466401

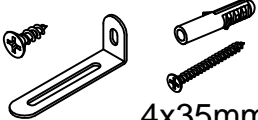
					
28	1pc	31	1pc	32	1pc
					
33	1pc	34	1pc	36	2pcs
 Hardware Kit x1					

SKU N635P466401

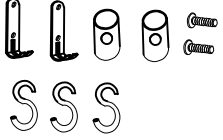
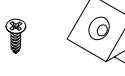
		 <p>6x30mm</p>	 <p>4x35mm</p>
<p>A 95+2pcs</p>	<p>B 95+2pcs</p>	<p>C 52+2pcs</p>	<p>D 28+2pcs</p>
 <p>3.5x14mm</p>	 <p>4x18mm</p>	 <p>3x16mm</p>	
<p>E 22+2pcs</p>	<p>F 2pcs</p>	<p>G 1pc</p>	<p>H 4pcs</p>
	<p>3.5x14mm</p>  <p>4x35mm</p>	 <p>3x12mm</p>	 <p>Ø20mm</p>
<p>J 1pc</p>	<p>K 2pcs</p>	<p>L 2pcs</p>	<p>M 24+2pcs</p>
		 <p>3.5x16mm</p>	
<p>N 1pc</p>	<p>P 1pc</p>	<p>Q 24+2pcs</p>	

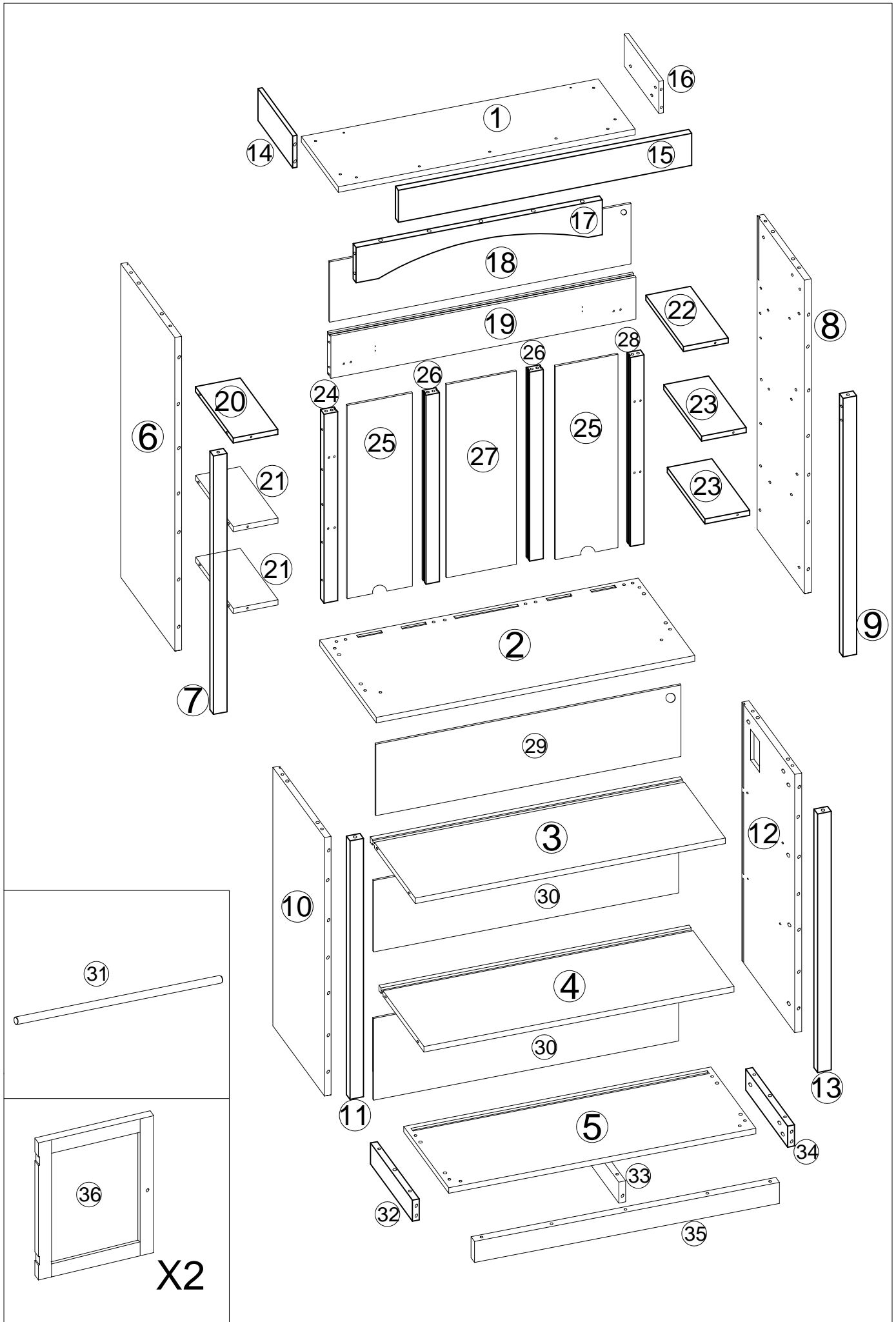

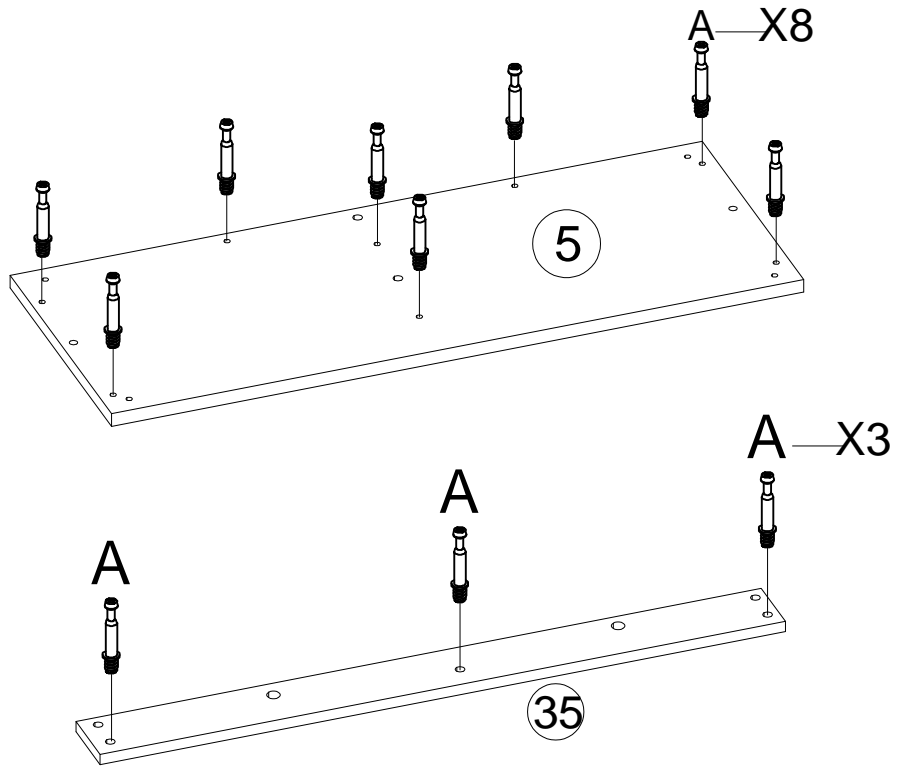

STEP 1

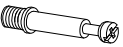

	
(A)	11pcs

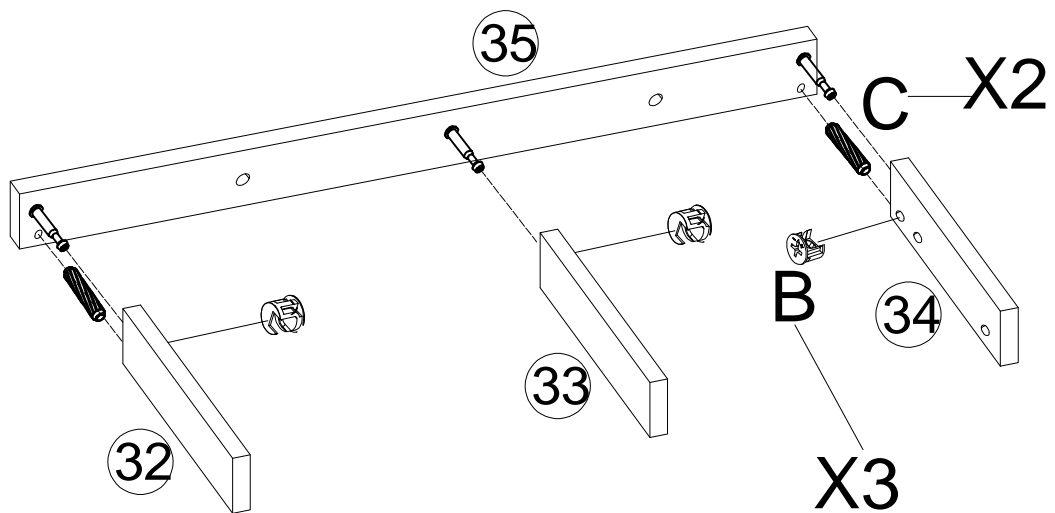

STEP 2

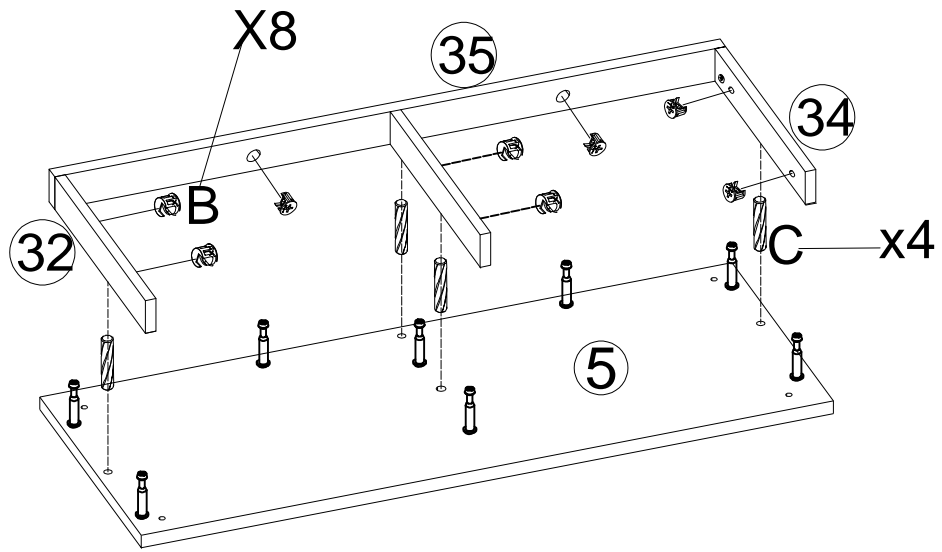

			
(B)	3pcs	(C)	2pcs

STEP 3



	
(B) 8pcs	(C) 4pcs

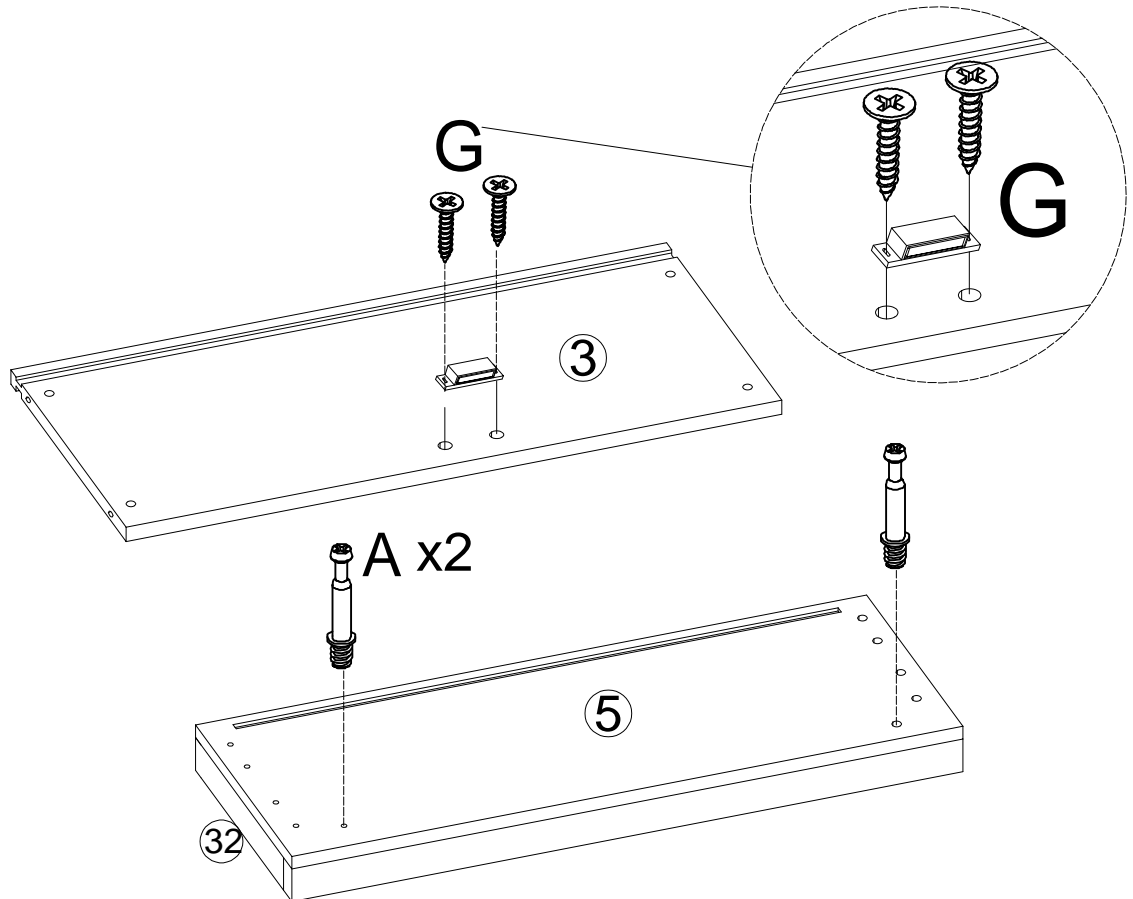

STEP 4

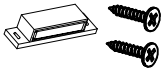

	
(A) 2pcs	(G) 1pc

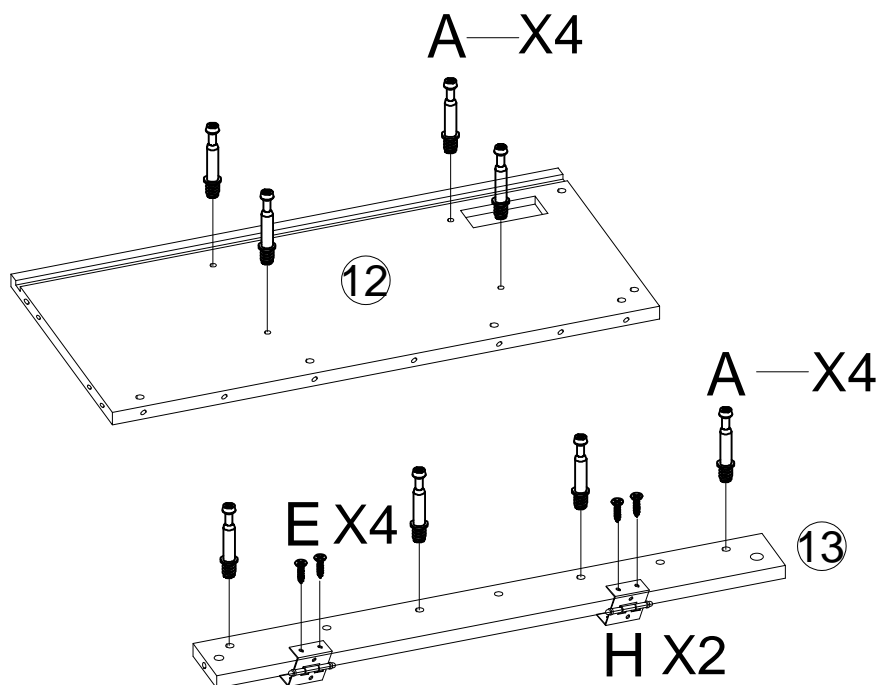

STEP 5



		
(A) 8pcs	(E) 4pcs	(H) 2pcs

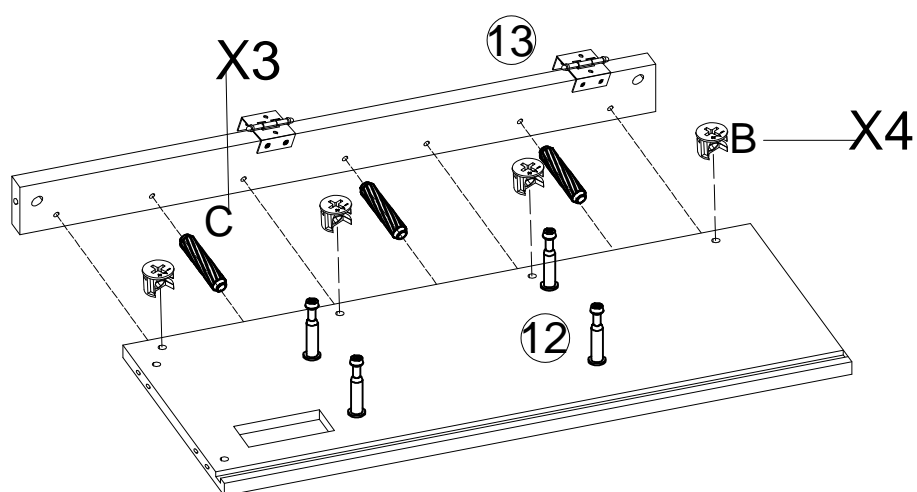

STEP 6



	
(B) 4pcs	(C) 3pcs

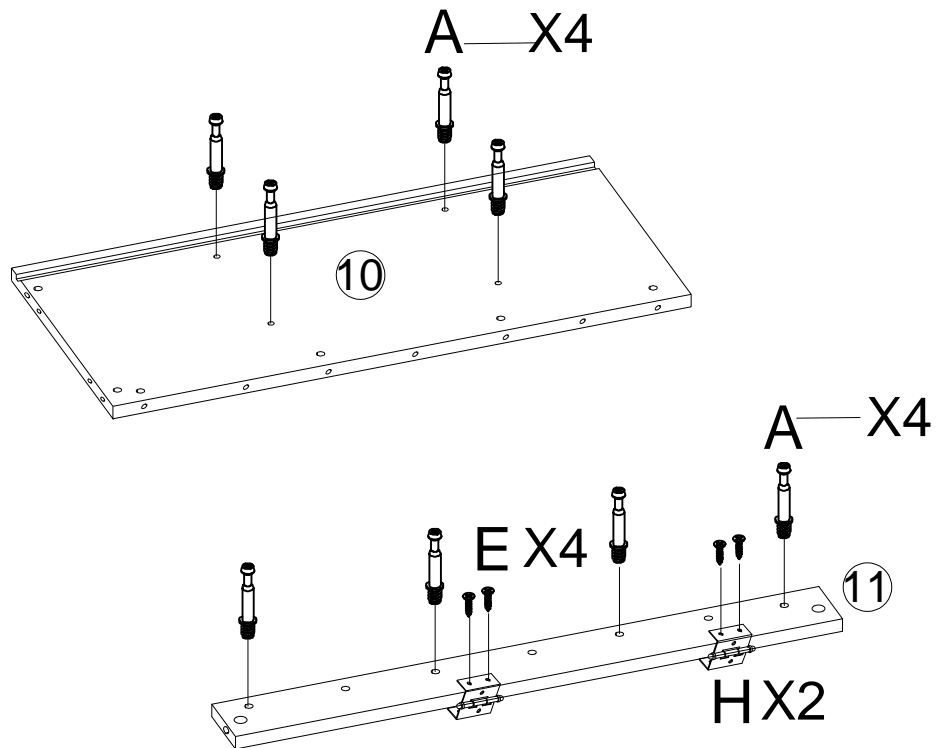

STEP 7

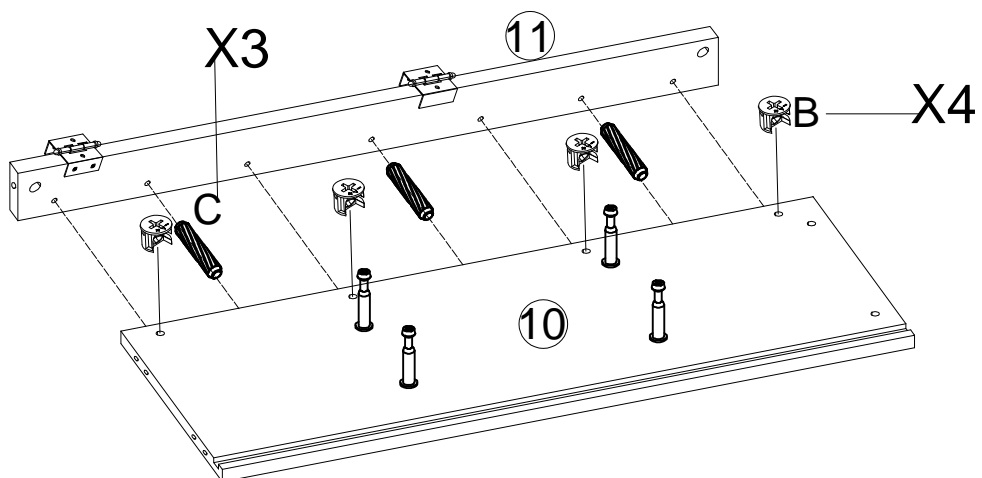

		
(A) 8pcs	(E) 4pcs	(H) 2pcs

STEP 8



	
(B) 4pcs	(C) 3pcs

STEP 9

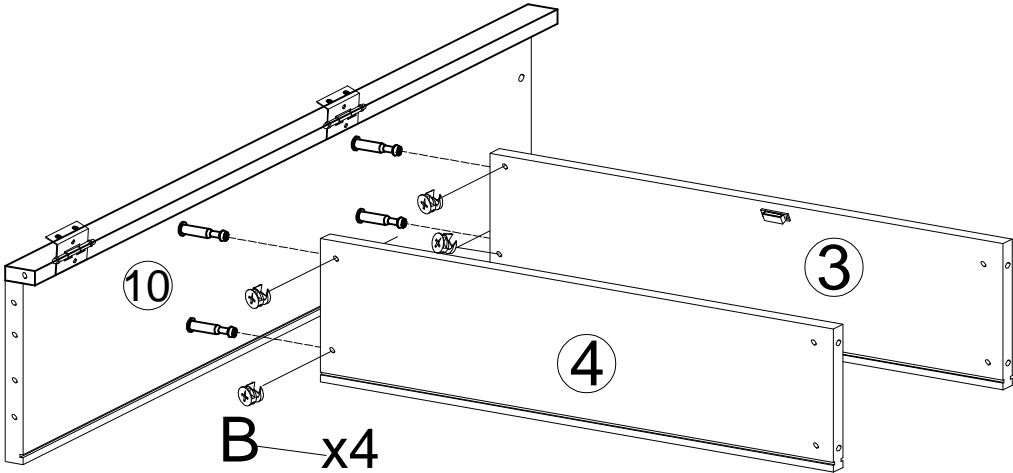

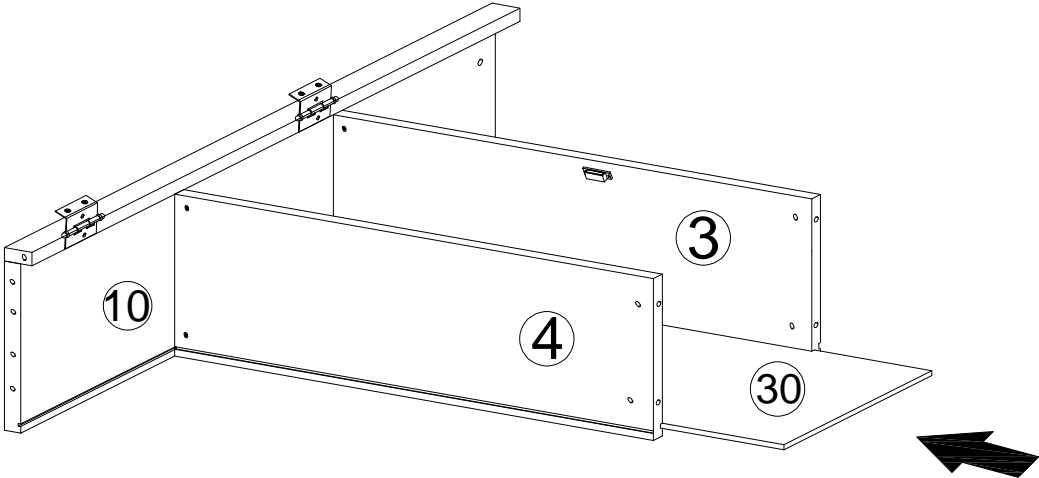

(B) 4pcs

STEP 10

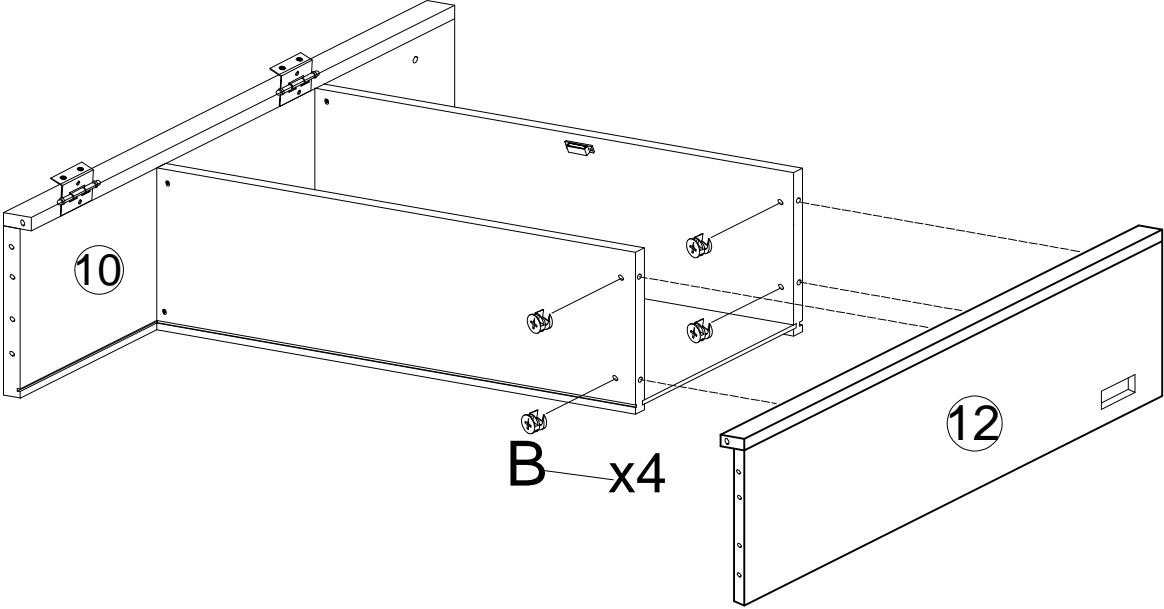

STEP 11



(B)	4pcs

STEP 12

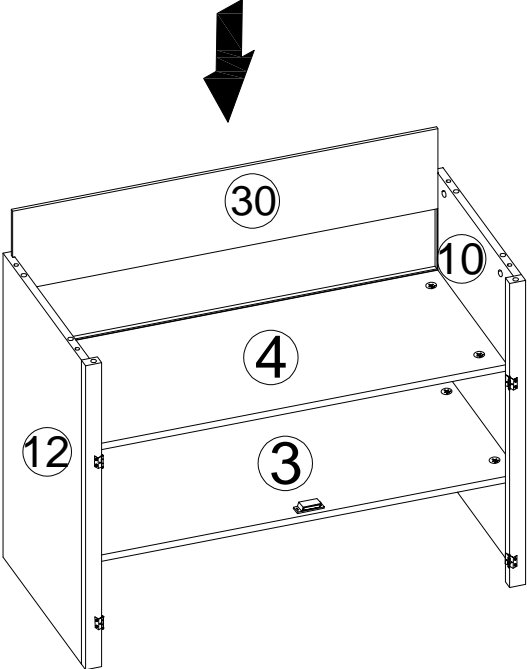

STEP 13

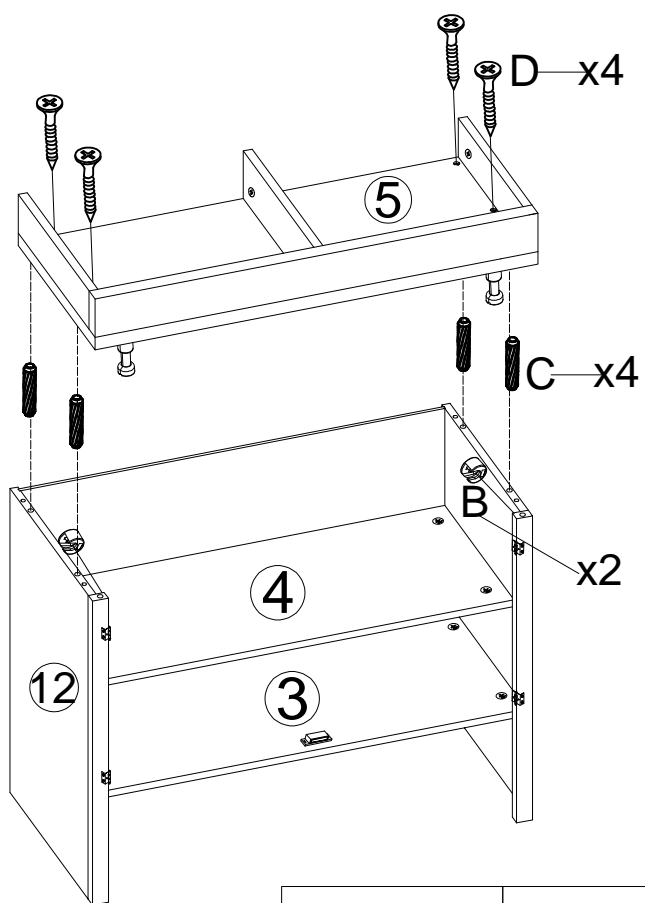

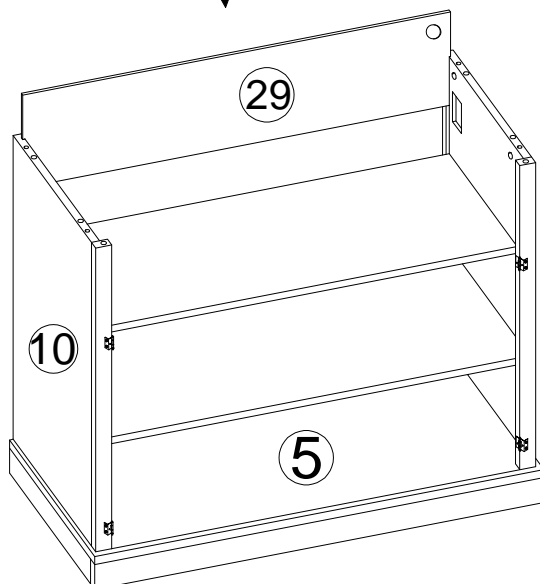

(B) 2pcs	(C) 4pcs	(D) 4pcs

STEP 14



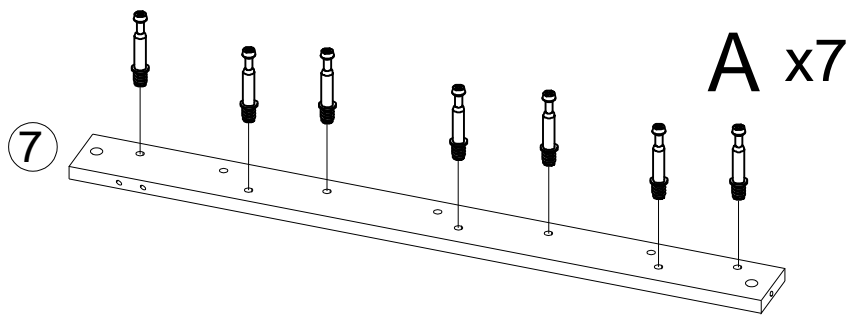
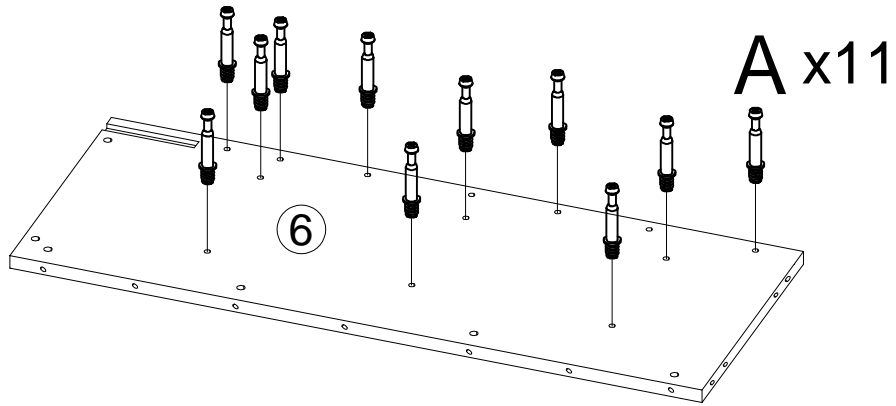

STEP 15



	
(A)	18pcs

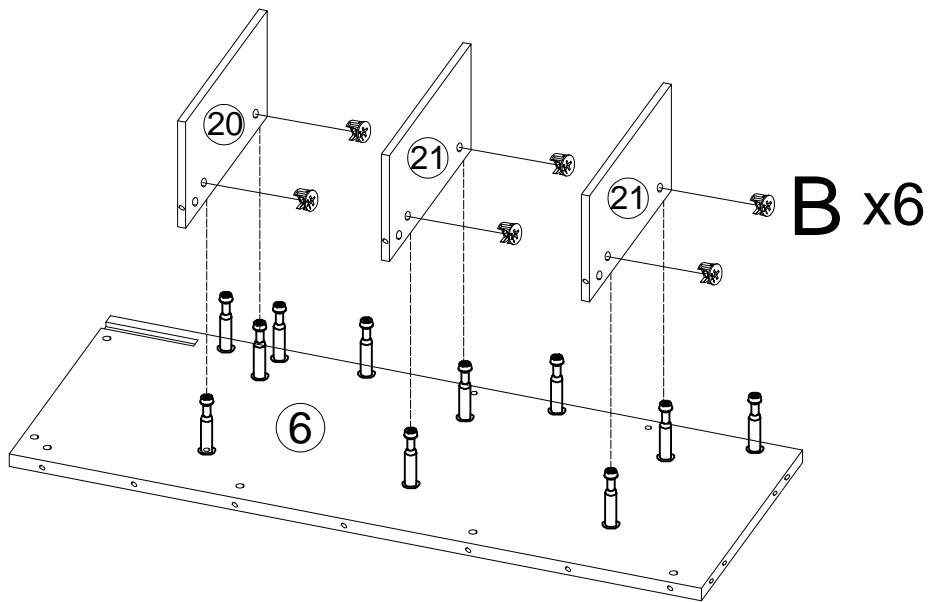

STEP 16

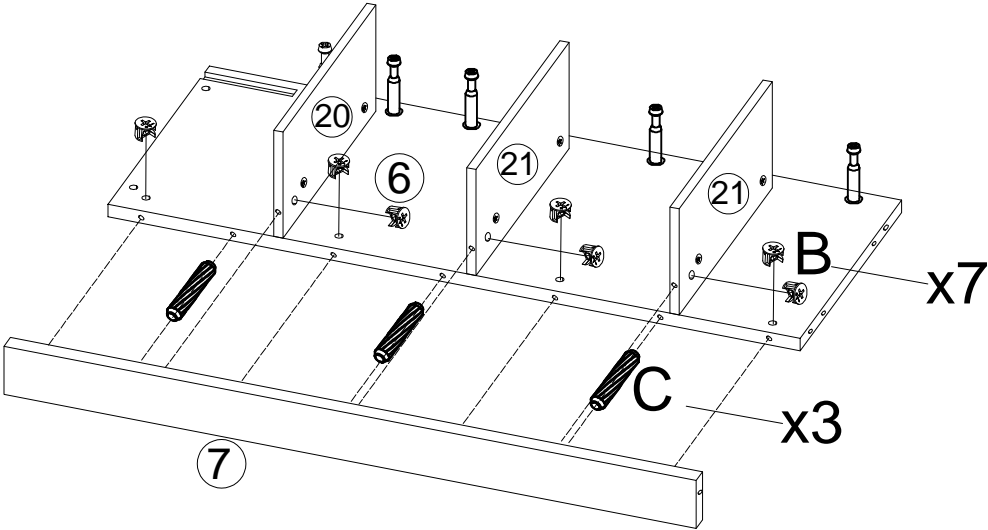

	
(B)	6pcs

STEP 17



	
(B) 7pcs	(C) 3pcs

STEP 18

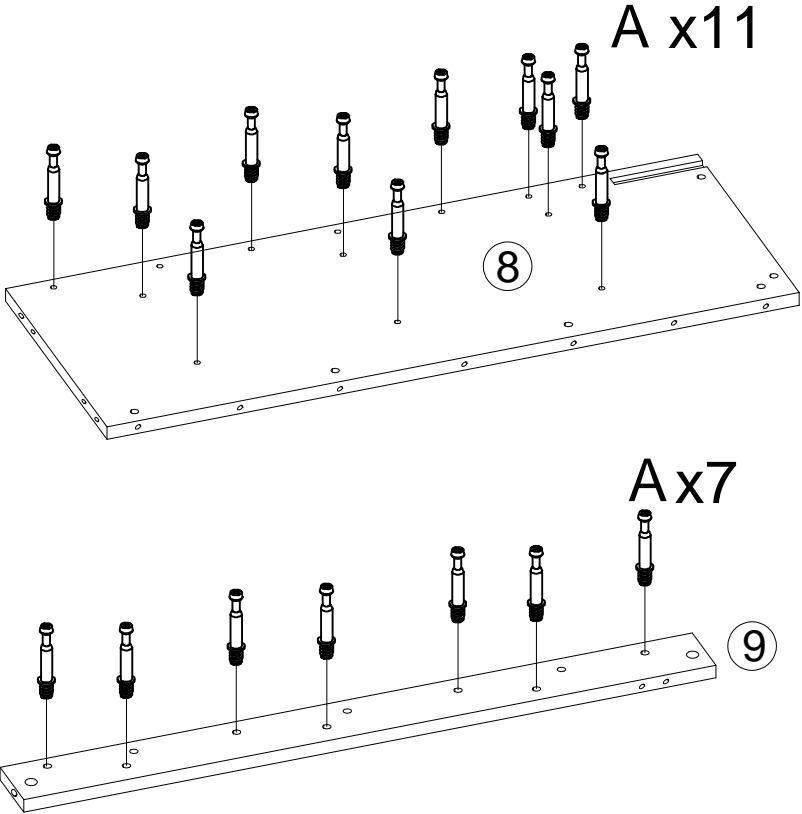



(A) 18pcs

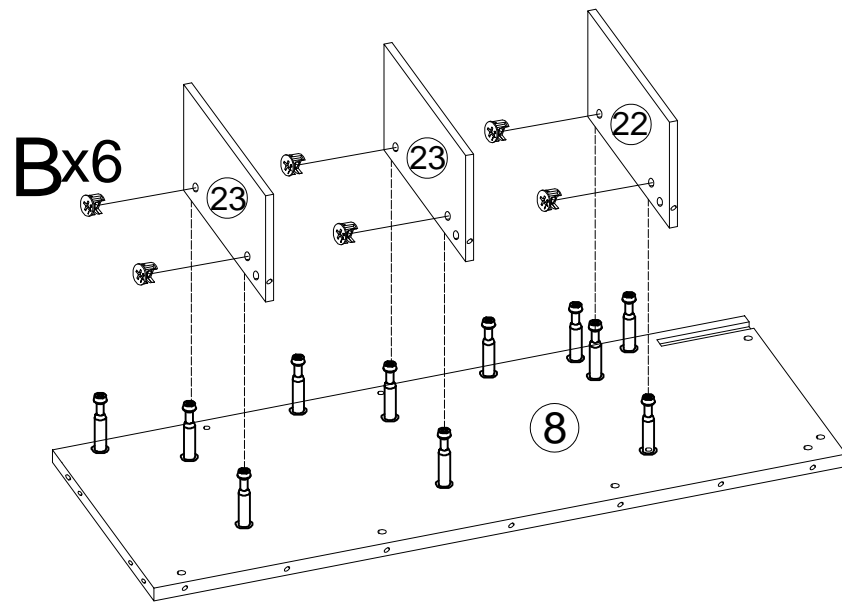

STEP 19

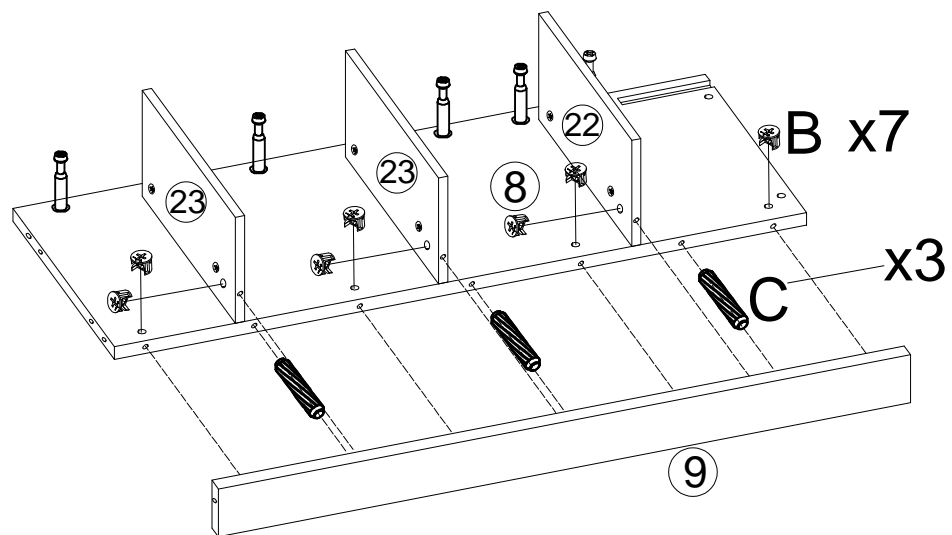

	
(B)	6pcs

STEP 20



			
(B)	7pcs	(C)	3pcs

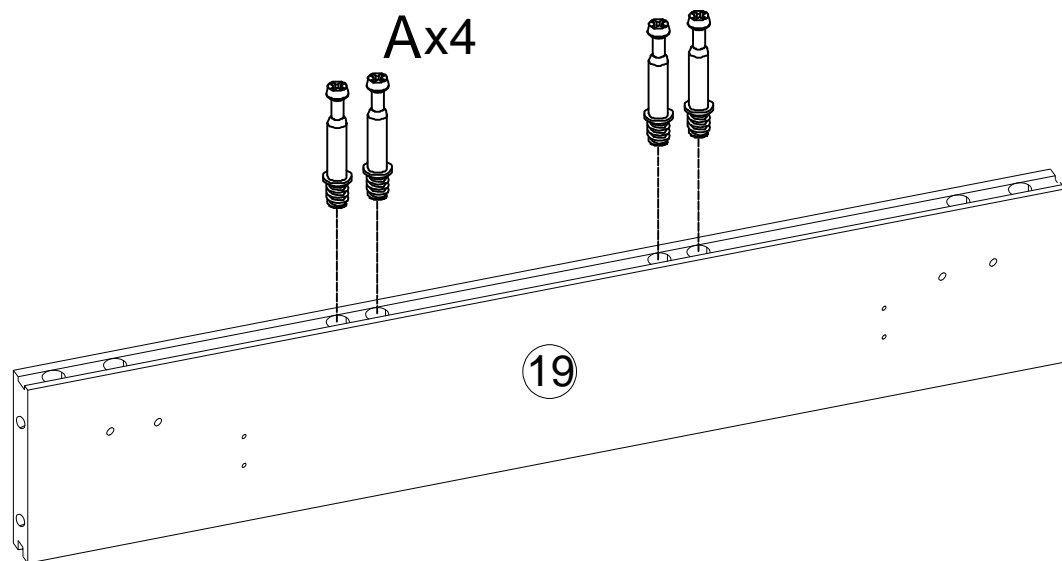

STEP 21

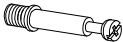

	
(A)	4pcs

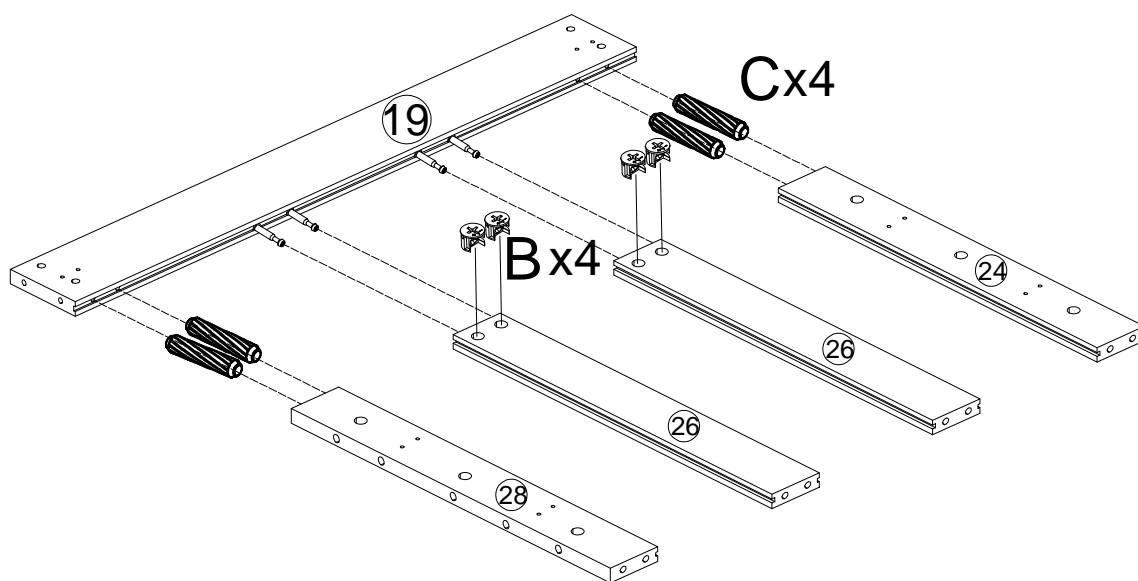
STEP 22



	
(B)	4pcs
(C)	4pcs

STEP 23

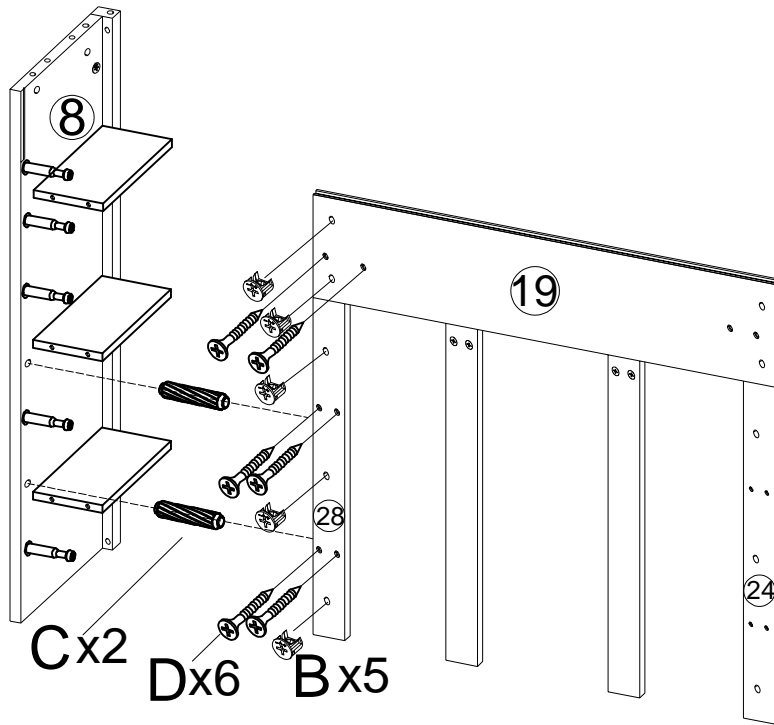

Cx2 Dx6 Bx5

(B) 5pcs	(C) 2pcs	(D) 6pcs

STEP 24

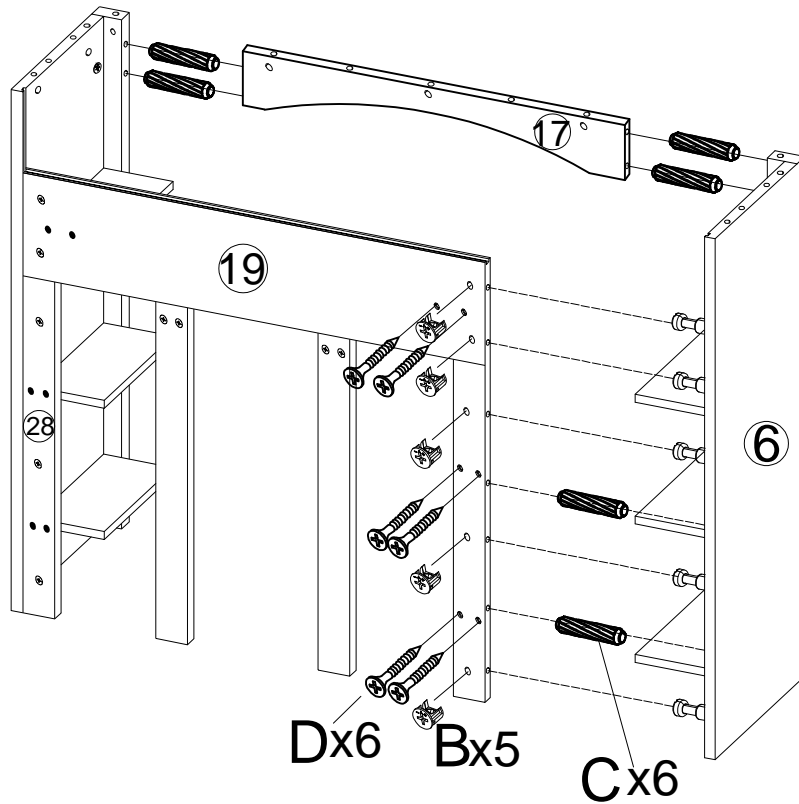

Dx6 Bx5 Cx6

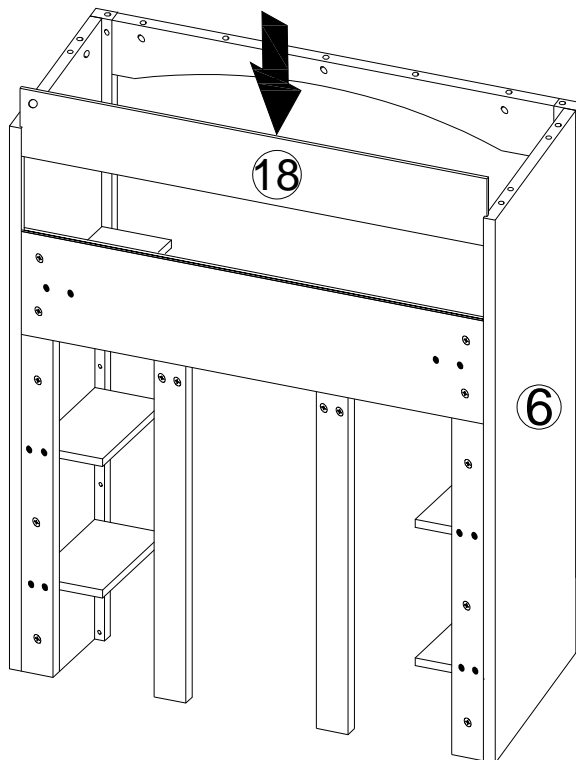

(B) 5pcs	(C) 6pcs	(D) 6pcs

STEP 25



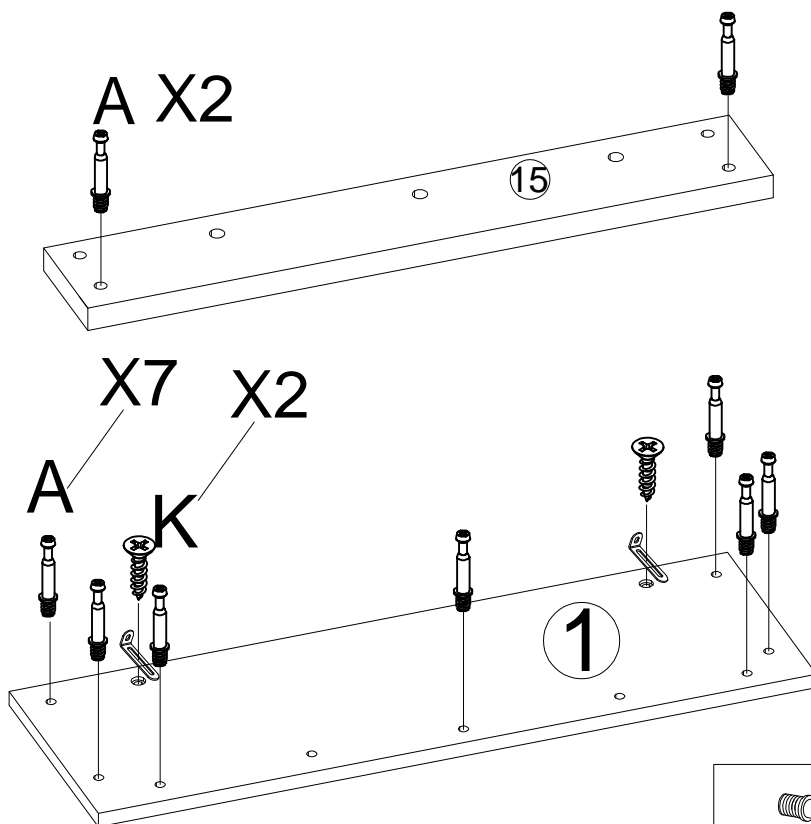

STEP 26



	
(A) 9pcs	(K) 2pcs

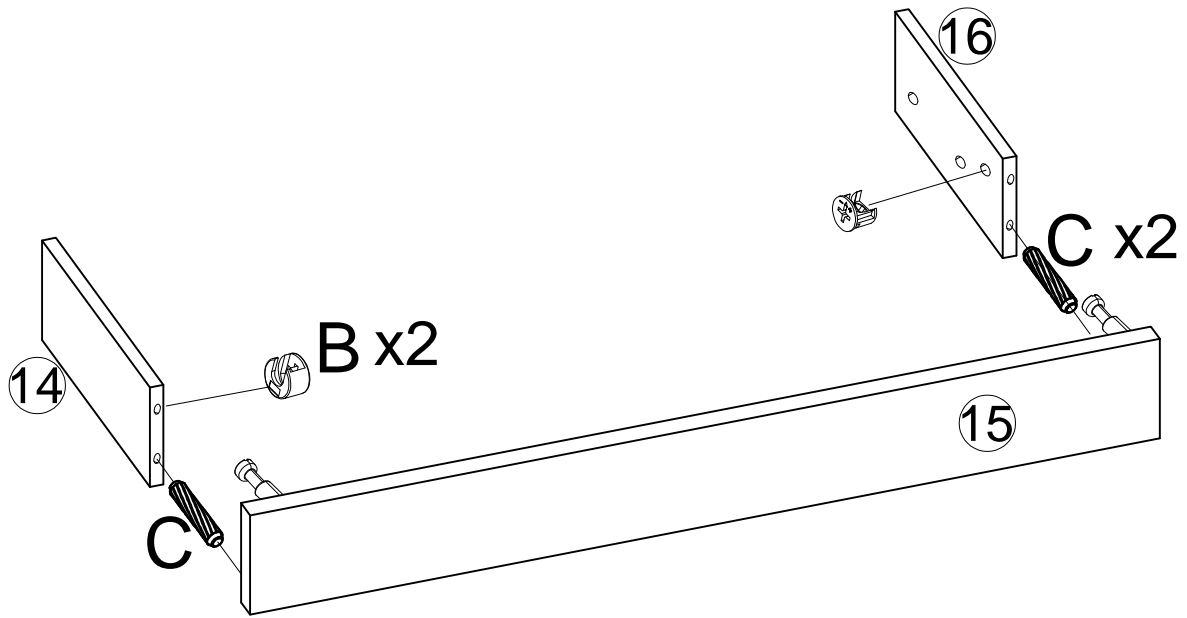

STEP 27

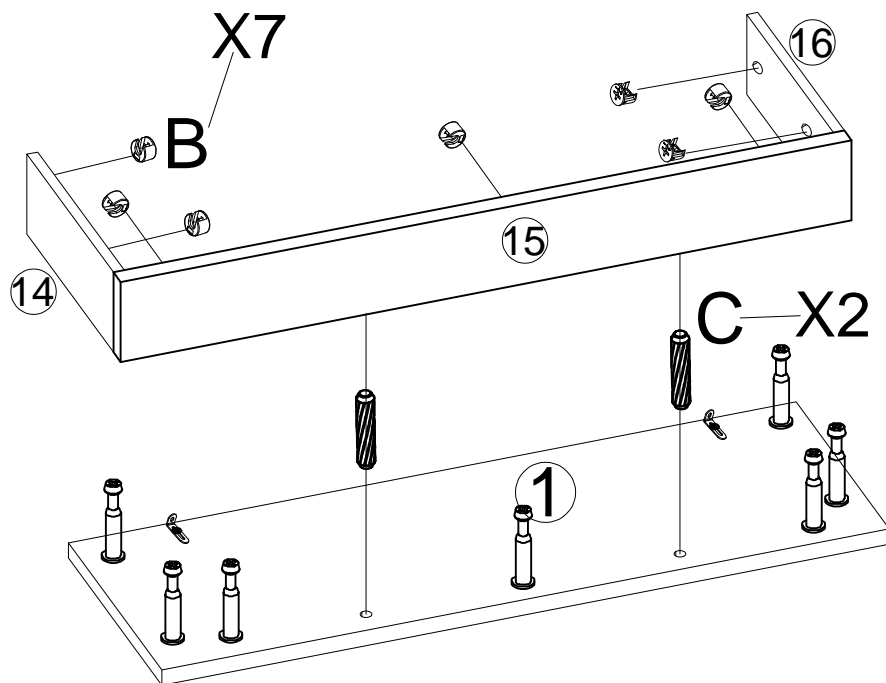

	
(B) 2pcs	(C) 2pcs

STEP 28



	
(B) 7pcs	(C) 2pcs

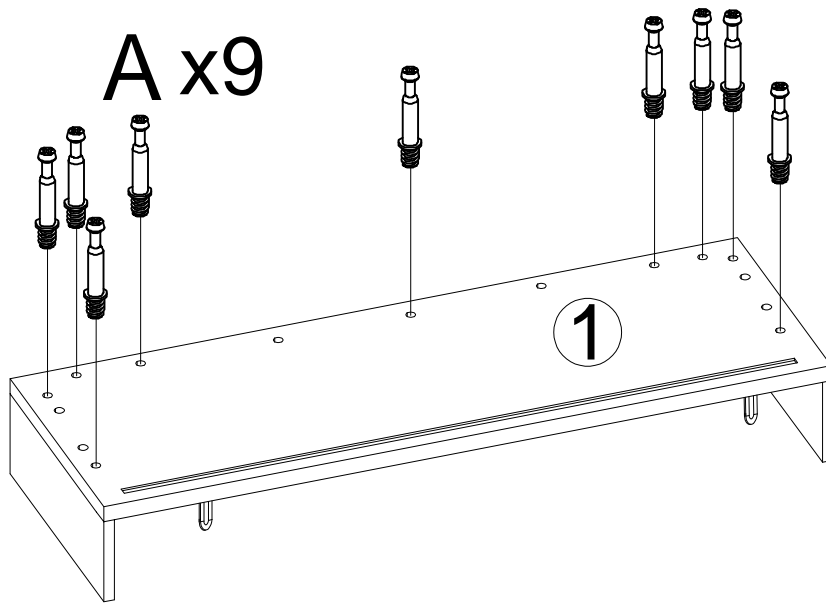

STEP 29

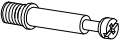

	
(A)	9pcs

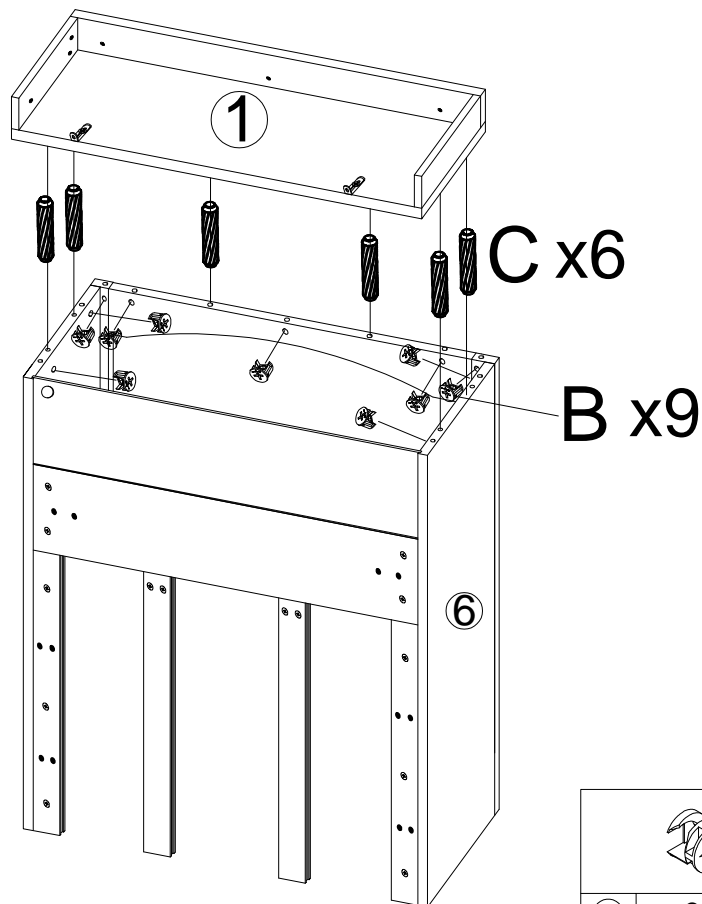
STEP 30



			
(B)	9pcs	(C)	6pcs

STEP 31

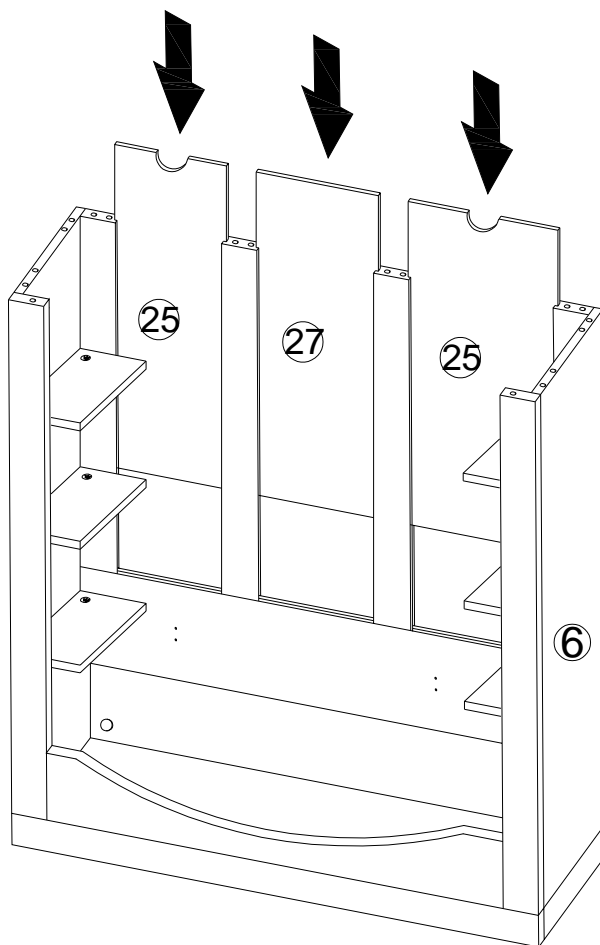



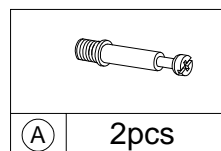
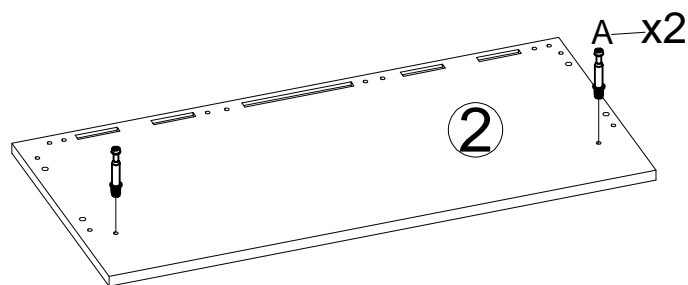

STEP 32

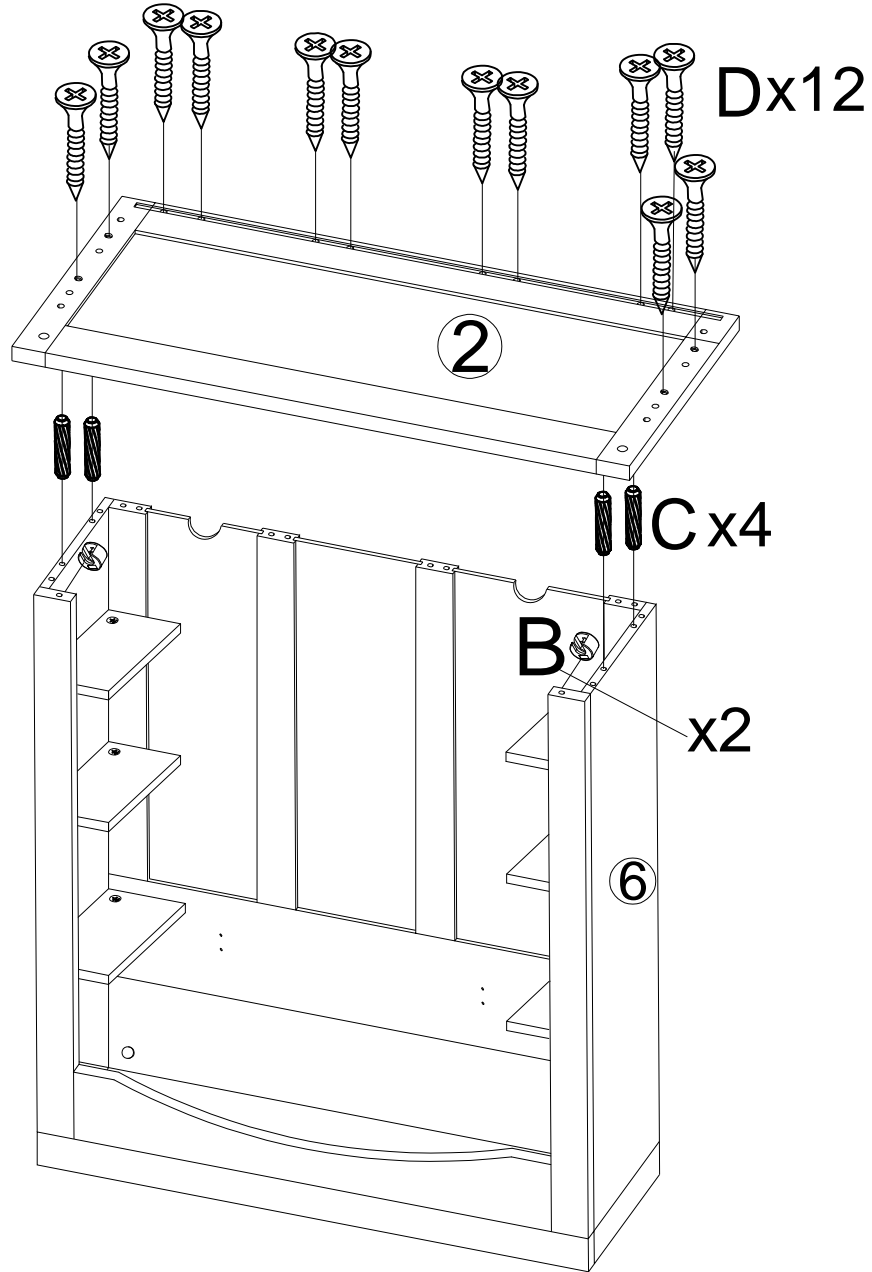

A 2pcs

STEP 33



		
(B) 2pcs	(C) 4pcs	(D) 12pcs

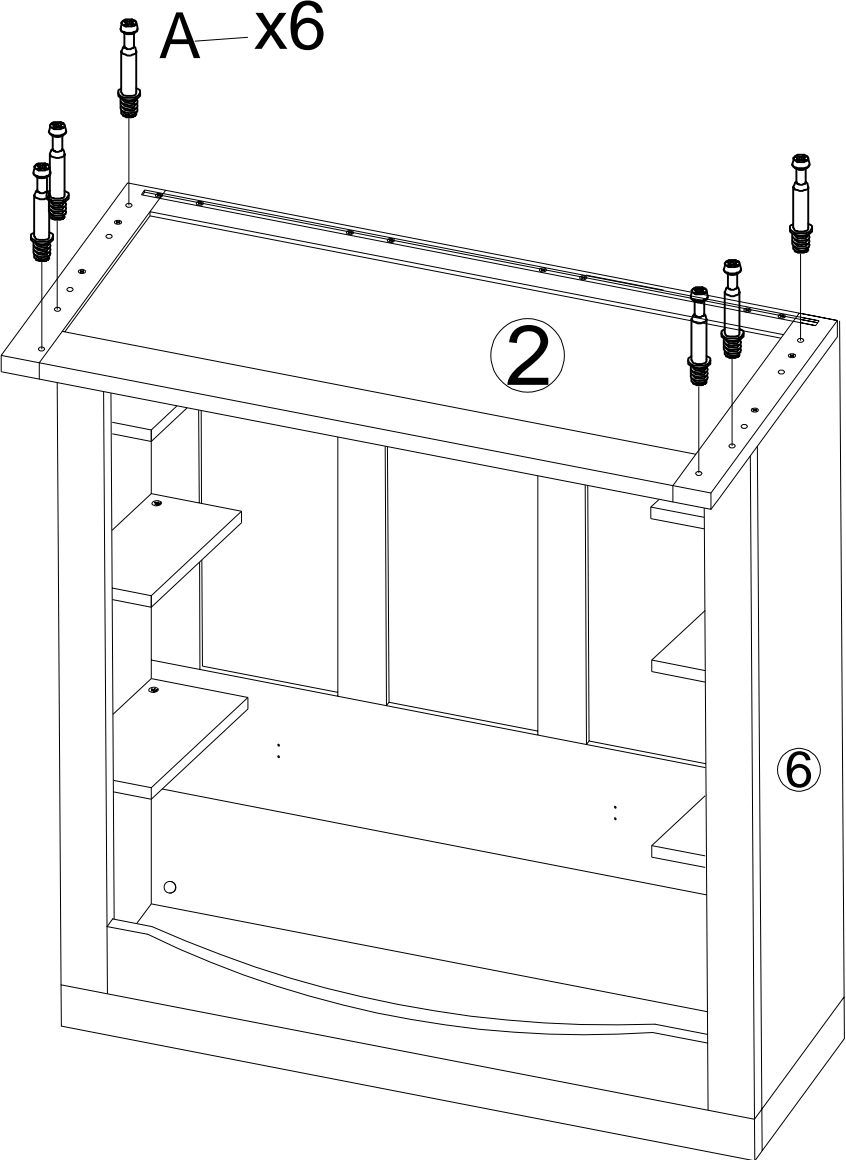

STEP 34

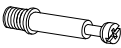

	
A	6pcs

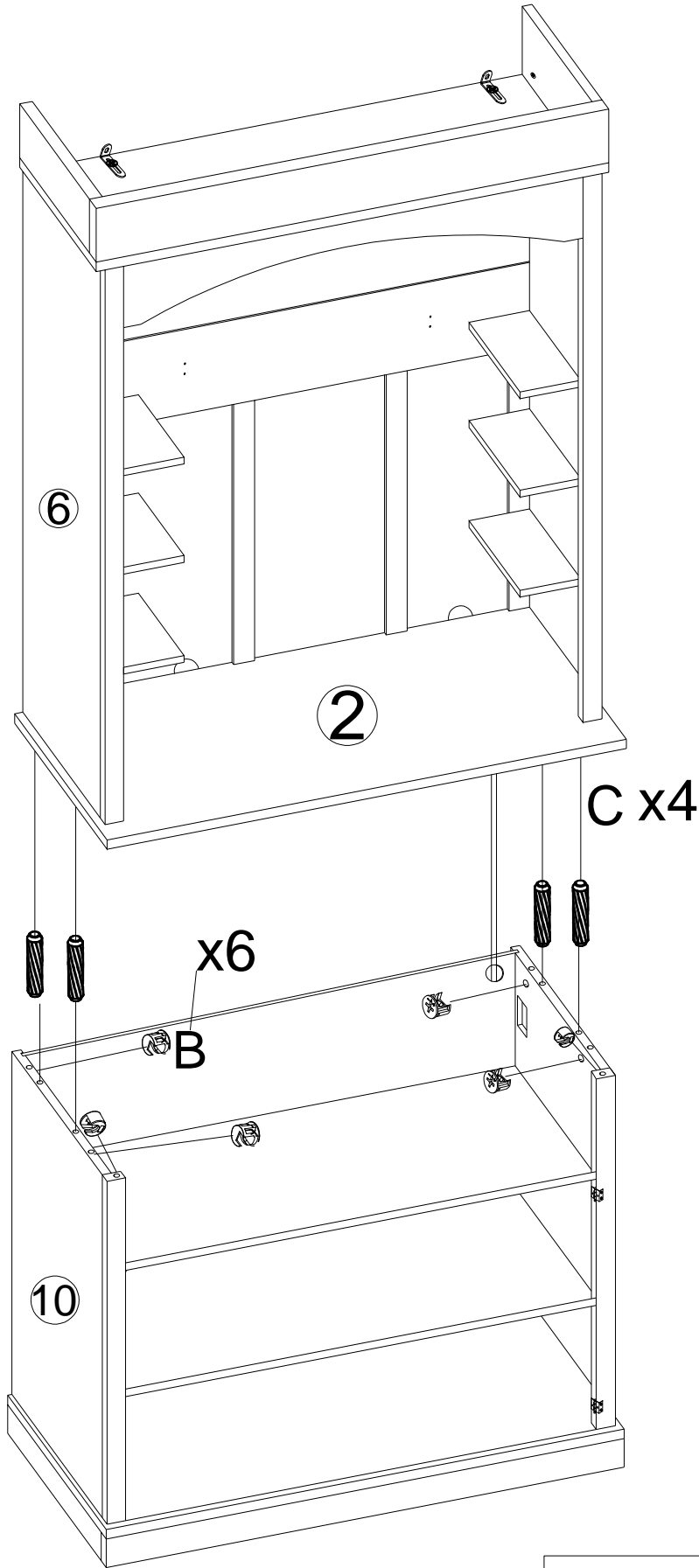

STEP 35

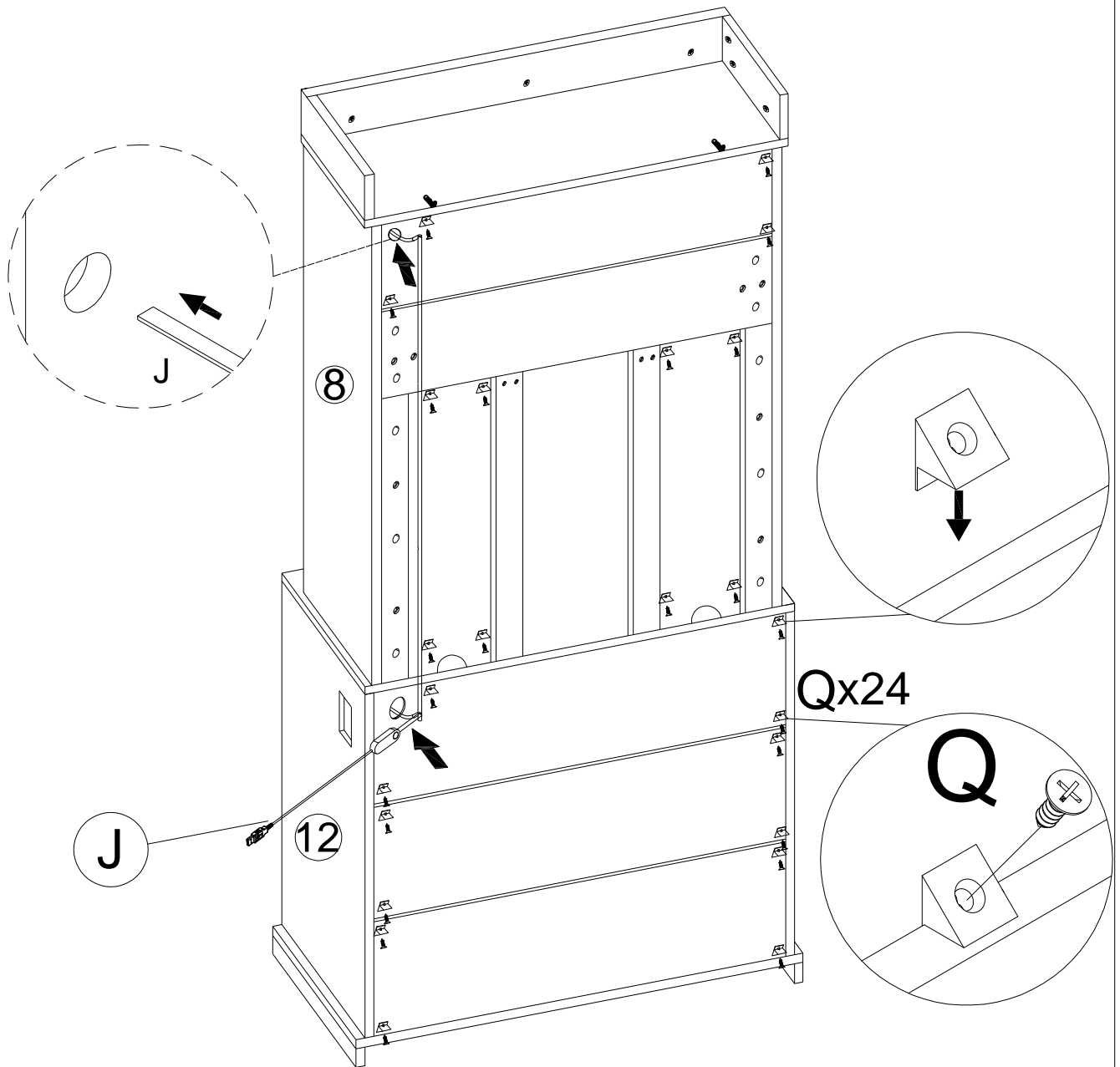

	
(B) 6pcs	(C) 4pcs

STEP 36



	
J 1pc	Q 24pcs

STEP 37

1)

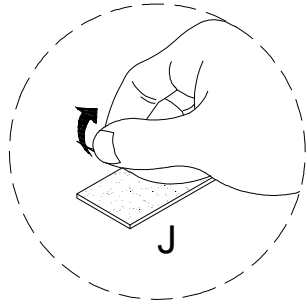

2)

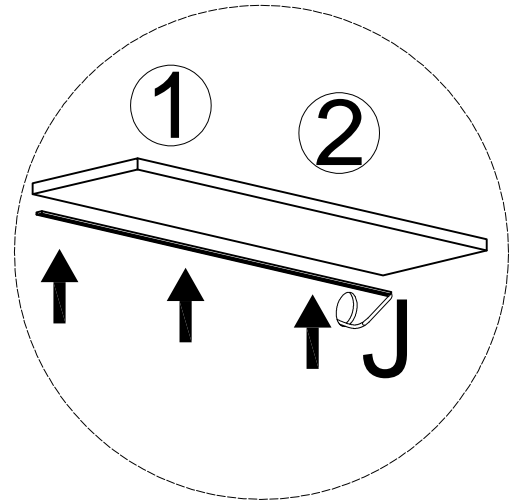
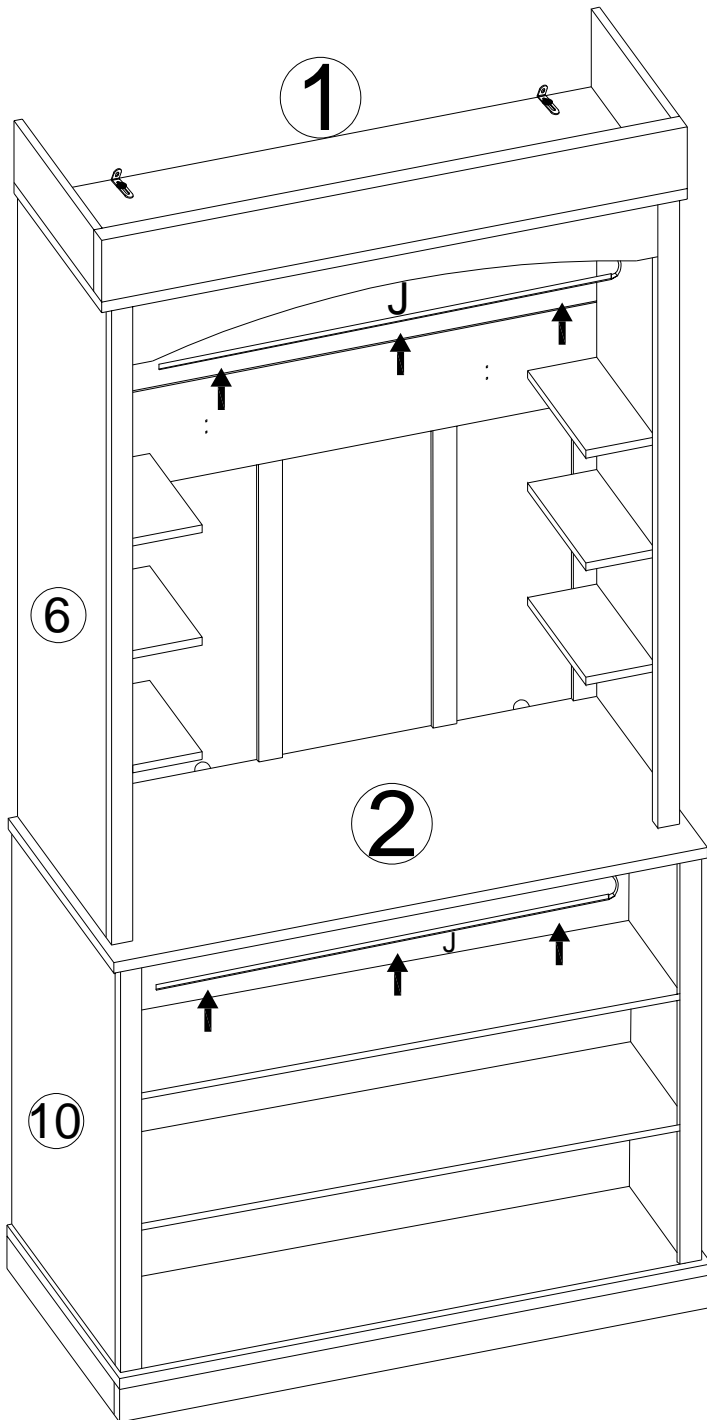
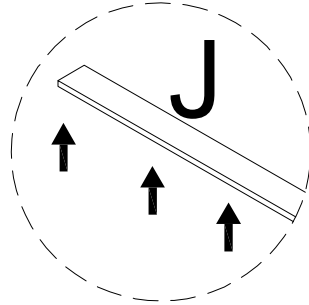

STEP 38

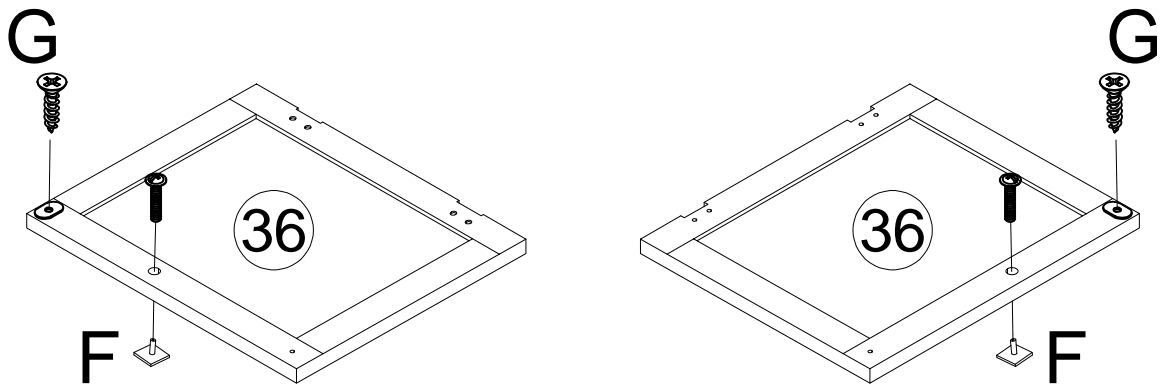

(F) 2pcs	(L) 2pcs

STEP 39

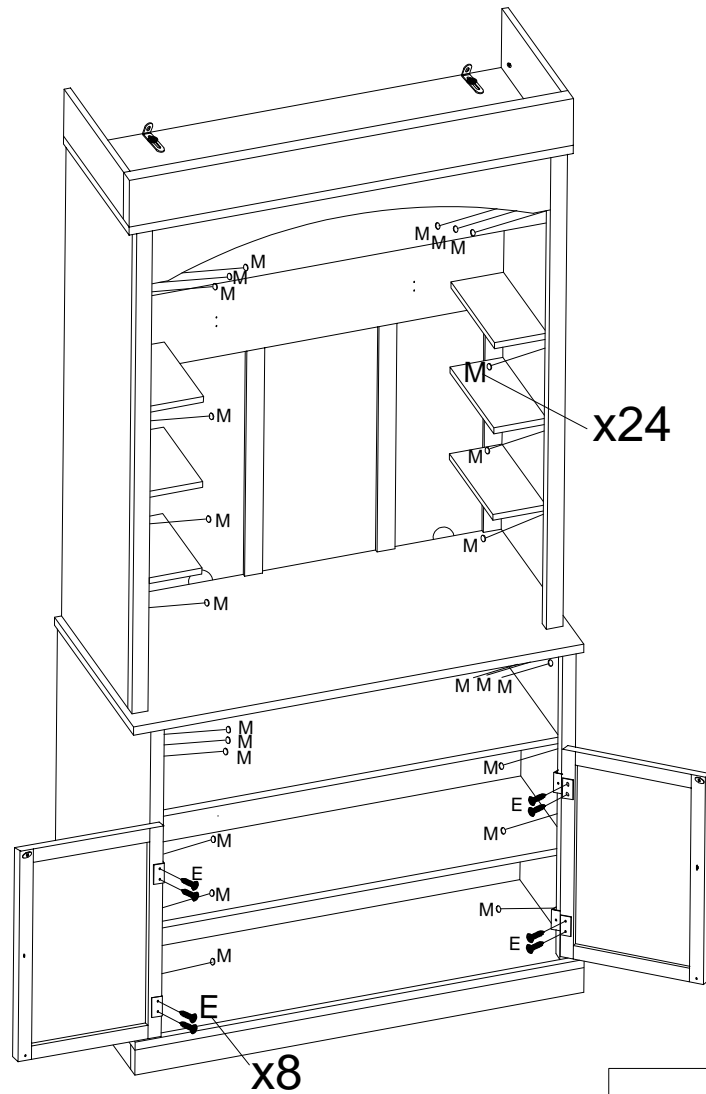

(M) 24pcs	(E) 8pcs

STEP 40

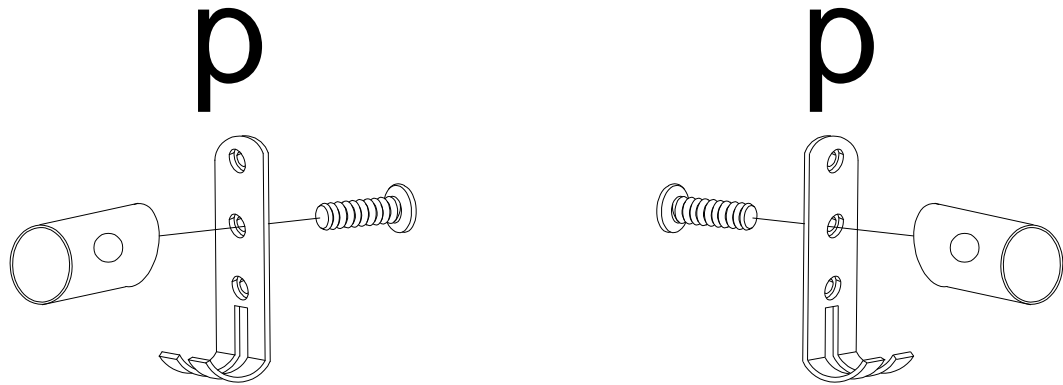



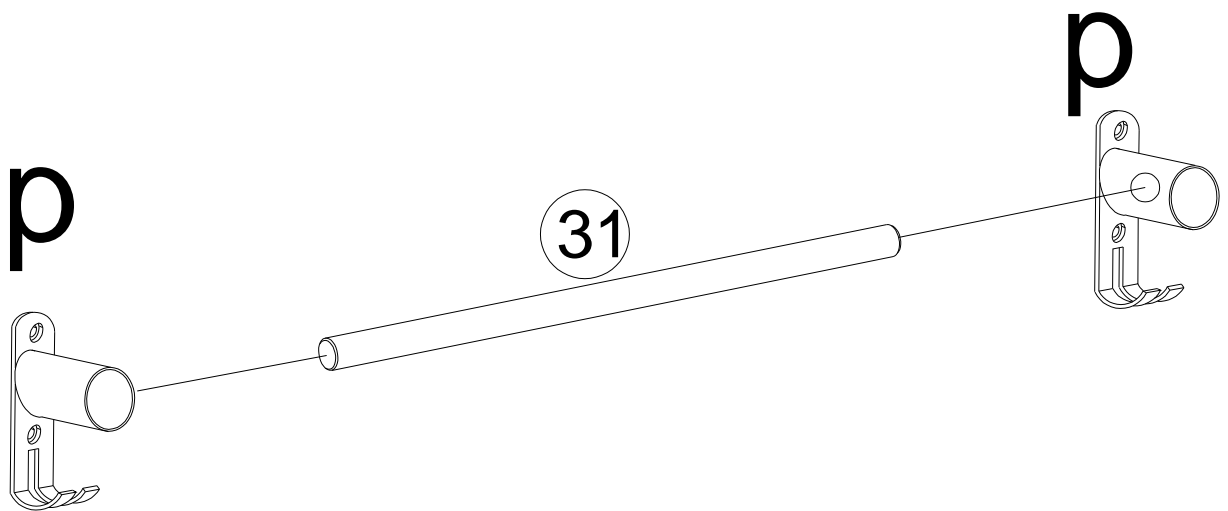

(P) 1pc

STEP 41

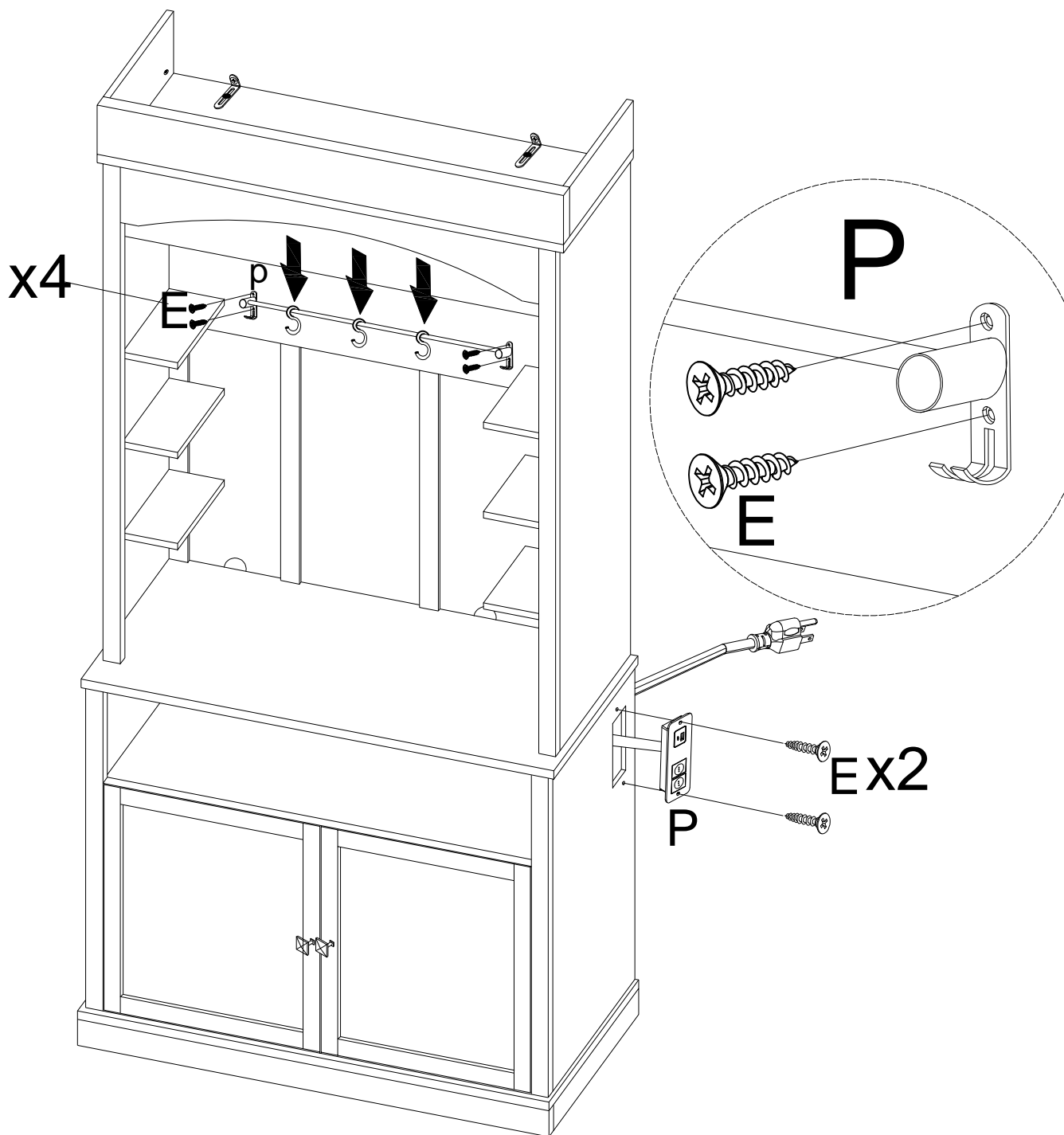

STEP 42



		
(E) 6pcs	(N) 1pc	(P) 1pc

STEP 43

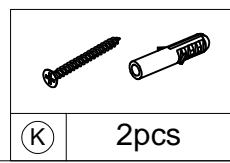
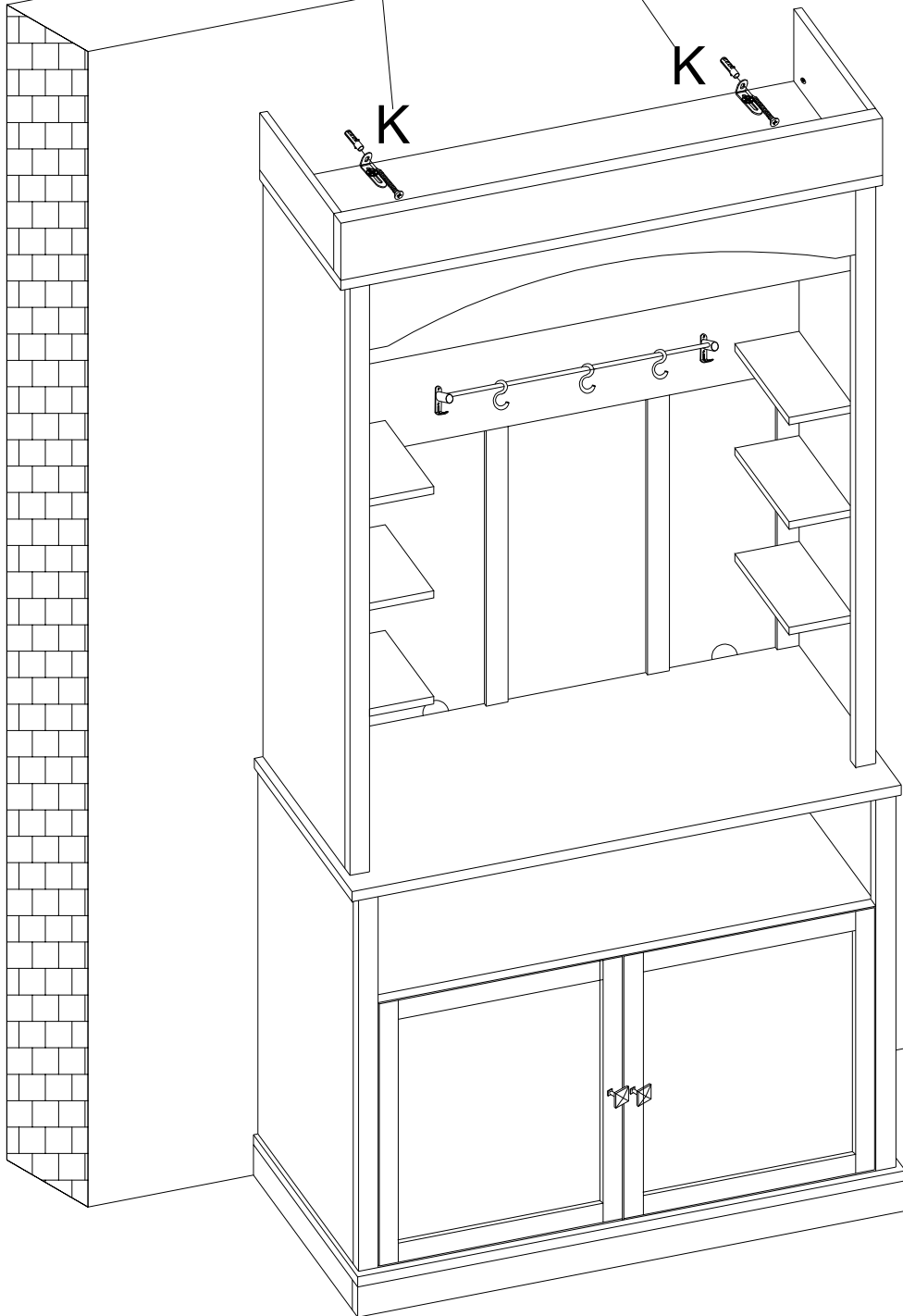
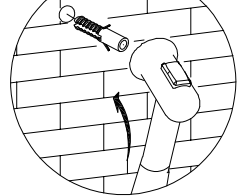
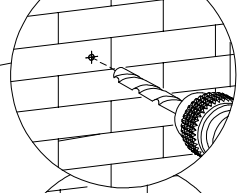
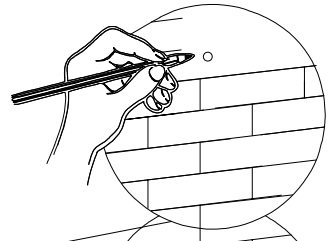
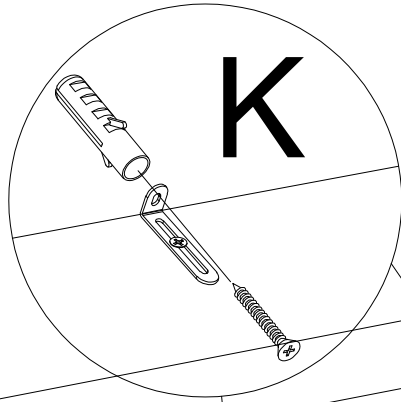

STEP 44

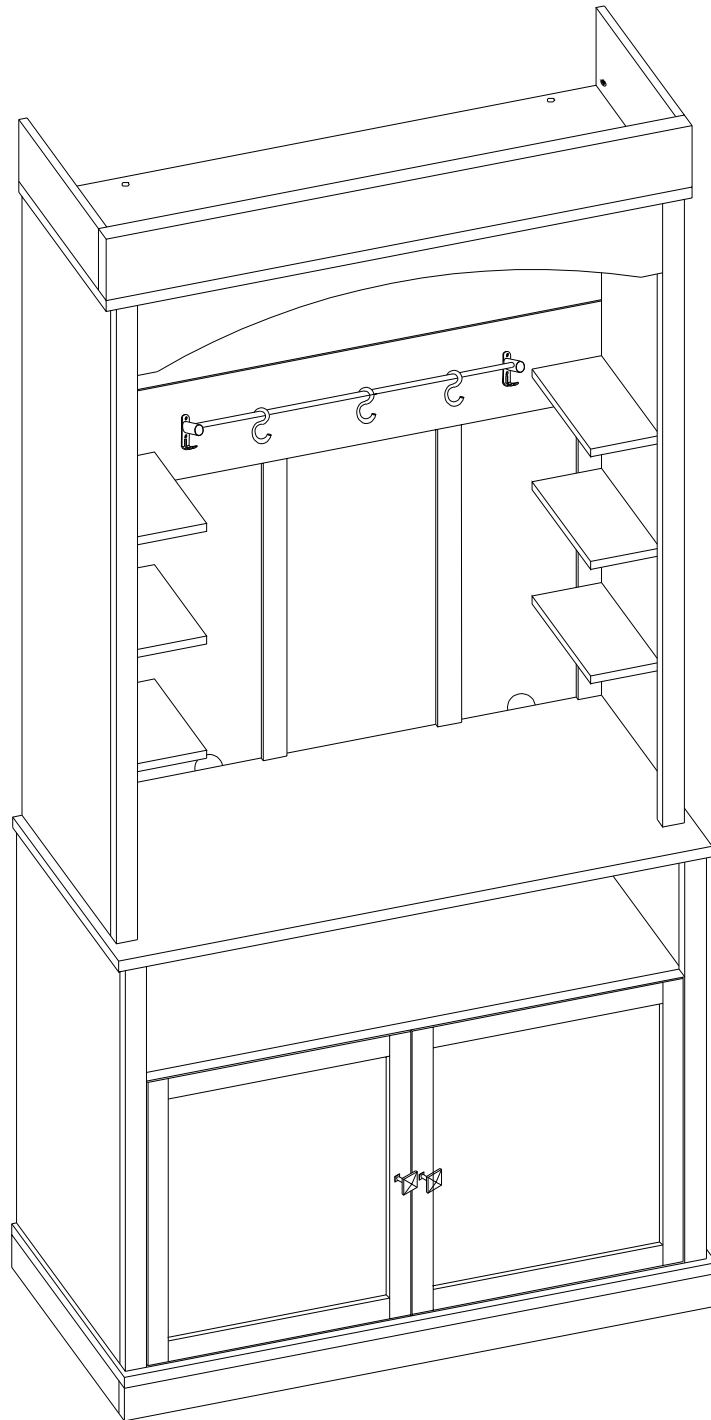



CERTIFICATE OF CONFORMITY

No.: LCT-250803286238

Applicant.....: GUANG TAI ENTERPRISE CO.,LTD.
Address.....: No. 2, Dapianmei District, Dalingshan Town, Dongguan City, Guangdong Province
Manufacturer.....: GUANG TAI ENTERPRISE CO.,LTD.
Address.....: No. 2, Dapianmei District, Dalingshan Town, Dongguan City, Guangdong Province
Product Name.....: Furniture power Distribution Unit
Model(s) JN02-00-112, JN02-00-111, JN02-00-211, JN02-00-22, JN02-00-113, JN02-00-213, JN02-00-113K, JN02-00-21, JN02-00-23, JN02-00-212
Trademark.....: N/A
Test Standard.....: EN 55032: 2015/A1: 2020; EN IEC 61000-3-2: 2019/A2: 2024; EN 61000-3-3:2013+A2:2021; EN 55035:2017/A11:2020.
Directives.....: EMC Directive 2014/30/EU
Report Number...: LCT-250803286238

Remark:

The tests were performed in normal operation mode, the test results apply only to the particular sample tested and to the specific tests carried out. This certificate applies specifically to the sample investigated in our test reference number only.

The CE markings as shown below can be affixed on the product after preparation of necessary technical documentation.

Other relevant Directives have to be observed.



(Manager)

Aug. 26, 2025



CERTIFICATE OF CONFORMITY

No.: LCT-250803286239

Applicant.....: GUANG TAI ENTERPRISE CO.,LTD.
Address.....: No. 2, Dapianmei District, Dalingshan Town, Dongguan City, Guangdong Province
Manufacturer.....: GUANG TAI ENTERPRISE CO.,LTD.
Address.....: No. 2, Dapianmei District, Dalingshan Town, Dongguan City, Guangdong Province
Product Name.....: Furniture power Distribution Unit
Model(s) JN02-00-112, JN02-00-111, JN02-00-211, JN02-00-22, JN02-00-113, JN02-00-213, JN02-00-113K, JN02-00-21, JN02-00-23, JN02-00-212
Trademark.....: N/A
Test Standard.....: IEC 62368-1:2023
 EN IEC 62368-1: 2024 + A11:2024
Directives.....: LVD Directive 2014/35/EU
Report Number...: LCT-250803286239

Remark:

The tests were performed in normal operation mode, the test results apply only to the particular sample tested and to the specific tests carried out. This certificate applies specifically to the sample investigated in our test reference number only.

The CE markings as shown below can be affixed on the product after preparation of necessary technical documentation.

Other relevant Directives have to be observed.



Aug. 26, 2025

Certificate of Compliance

RoHS Directive 2011/65/EU appendix I Revised instructions (EU) 2015/863 of the European parliament and of the council on the restriction of the use of certain hazardous substances in electrical and electronic equipment

Issue Date: Nov.27, 2025

Company Name	: GUANG TAI ENTERPRISE CO.,LTD
Address	: Rm402,Bldg 4,No.2 Dapianmei Rd.Dapianmei Village,Dalingshang DONGGUAN GUANGDONG
Manufacturer	: GUANG TAI ENTERPRISE CO.,LTD
Address	: Rm402,Bldg 4,No.2 Dapianmei Rd.Dapianmei Village,Dalingshang DONGGUAN GUANGDONG
Sample Name	: Furniture Power Distribution Unit
Sample Model	: JN02-00-21;JN02-00-111;JN02-00-112;JN02-00-212; JN02-00-22;JN00-00-02K;JN02-00-113K;JN02-00-113; JN02-00-213;JN02-00-23;JN00-00-03K;JN00-00-03; JN00-00-04K;JN00-00-04; JN02-00-23K

This certificate of compliance is based on a test procedure or an evaluation of the above-mentioned product. This is to certify that the above-mentioned product is in compliance with the According to IEC63000:2018+AMD1:2017 and RoHS Directive 2011/65/EU Revised instructions (EU) 2015/863 of the European parliament.

It is only valid in connection with the test report (Report No.: COBO25110736-R1)

RoHS

Signed for and on Behalf of COBO



Sam Xie / Technical Manager

GUANGDONG TI COBO TESTING CO.,LTD.

E A601, Yeshi Building No.9,Zongbu 2nd Road,Songshan Lake Sci.&Tech. Park,Dongguan, Guangdong, China

Tel:86-769-26622283 Fax:86-769-26622012

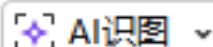

CERTIFICATE OF COMPLIANCE

No.: AiTSZ-250710061C-C01

Product: 5050 RGB LED Strip Lights with Bluetooth App Controller
Trade Mark: N/A
Model: LED 5050 RGB
Applicant: Shenzhen Pinchengxin Technology Co., Ltd
Address: 3rd floor, 8 building Yuanling industrial zon, No. 39 Yuanlingcun road,Shiyan street, Bao'an district, Shenzhen
Manufacture: Shenzhen Pinchengxin Technology Co., Ltd
Address: 3rd floor, 8 building Yuanling industrial zon, No. 39 Yuanlingcun road,Shiyan street, Bao'an district, Shenzhen

The test sample of product has passed the test according to requirements of the following standards:

Standard(s):	Test report(s) No.:
EN 55032:2015+A11:2020 EN 55035:2017+A11:2020	AiTSZ-250710061CE1

Based on the voluntary assessment of the product sample and technical file, we confirm that the above-mentioned product meets the essential requirements of the Electromagnetic Compatibility (EMC) Directive 2014/30/EU.

The CE mark as show below can be used, under the responsibility of the manufacturer or the importer, after completion of an EC declaration of conformity and follow the CE mark usage rules.

CE

Approved by/Date:



Allen.Wang

Jul 23, 2025



The statement is based on a single evaluation of one sample of above mentioned products. It does not imply an assessment of the whole production and does not permit the use of the test lab's logo.

Guangdong Asia Hongke Test Technology Limited

B1/F, Building 11, Junfeng Industrial Park, Chongqing Road, Heping Community, Fuhai Street,
Bao'an District, Shenzhen, Guangdong, China

www.aitek.org.cn

E-mail:info@aitek.org.cn



CERTIFICATE OF COMPLIANCE

No.: AiTSZ-250710061C-C02

Product: 5050 RGB LED Strip Lights with Bluetooth App Controller
Trade Mark: N/A
Model: LED 5050 RGB
Applicant: Shenzhen Pinchengxin Technology Co., Ltd
Address: 3rd floor, 8 building Yuanling industrial zon, No. 39 Yuanlingcun road,Shiyan street, Bao'an district, Shenzhen
Manufacture: Shenzhen Pinchengxin Technology Co., Ltd
Address: 3rd floor, 8 building Yuanling industrial zon, No. 39 Yuanlingcun road,Shiyan street, Bao'an district, Shenzhen

The test sample of product has passed the test according to requirements of the following standards:

	Standard(s):	Test report(s) No.:
Article 3.1a)	EN 60598-2-4:2018 used in conjunction with EN IEC 60598-1:2021+A11:2022	AiTSZ-250710061S
	EN 62479: 2010 EN 50663: 2017	AiTSZ-250710061CW3
Article 3.1b)	ETSI EN 301 489-1 V2.2.3 (2019-11) ETSI EN 301 489-17 V3.2.4 (2020-09)	AiTSZ-250710061CW1
Article 3.2)	ETSI EN 300 328 V2.2.2 (2019-07)	AiTSZ-250710061CW2

Based on the voluntary assessment of the product sample and technical file, we confirm that the above-mentioned product meets the essential requirements of the Radio Equipment Directive (RED) 2014/53/EU.

The CE mark as show below can be used, under the responsibility of the manufacturer or the importer, after completion of an EC declaration of conformity and follow the CE mark usage rules.



Approved by/Date:

Sean She
Sean She

Aug.07 2025



The statement is based on a single evaluation of one sample of above mentioned products. It does not imply an assessment of the whole production and does not permit the use of the test lab's logo.

Guangdong Asia Hongke Test Technology Limited

B1/F, Building 11, Junfeng Industrial Park, Chongqing Road, Heping Community, Fuhai Street,
Bao'an District, Shenzhen, Guangdong, China

www.aitek.org.cn

E-mail:info@aitek.org.cn



Certificate of Compliance

Certificate No.: AITSZ-250710061RC09

The EUT described above has been consolidated by us and found in compliance with the council RoHS 2.0 Directive(EU)2015/863and(EU)2017/2102 amending Annex I to Directive2011/65/EU.

Applicant : Shenzhen Pinchengxin Technology Co., Ltd
Address : 3rd floor, 8 building Yuanling industrial zon, No. 39 Yuanlingcun road, Shiyan street, Bao'an district, Shenzhen
Manufacturer : Shenzhen Pinchengxin Technology Co., Ltd
Address : 3rd floor, 8 building Yuanling industrial zon, No. 39 Yuanlingcun road, Shiyan street, Bao'an district, Shenzhen
Product : 5050 RGB LED Strip Lights with Bluetooth App Controller
Model No. : LED 5050 RGB
Trade mark : N/A
Test Report No. : AITSZ-250710061R

Test Standards :

IEC 62321-3-1: 2013
IEC 62321-4:2013+AMD1:2017 CSV
IEC 62321-5:2013
IEC 62321-6:2015
IEC 62321-7-1:2015
IEC 62321-7-2:2017
IEC 62321-8:2017

RoHS

Lizhen

Lizhen

Date: Jul.18, 2025



The statement is based on a single evaluation of one sample of above mentioned products. It does not imply an assessment of the whole production and does not permit the use of the test lab logo.



Guangdong Asia Hongke Test Technology Co.,Ltd.

B1/F, Building 11, Junfeng Industrial Park, Chongqing Road, Heping Community, Fuhai Street, Bao'an District, Shenzhen, Guangdong, China

Tel:+86. 0755-23096763

<https://www.aitek.org.cn>

E-mail:info@aitek.org.cn