

























Read this instruction carefully. See hardware and furniture part list for guidance. Be sure all parts are complete, before you assemble. Place all wooden furniture parts on a clean and flat soft surface to prevent from being scratched. Follow the figure to start assembling.

- CAUTIONS** :
1. Do not FULLY - TIGHTEN the nut or nut bolt until all nut or bolt is ready assembled.
 2. Do not OVER - TIGHTEN the nut or bolt to avoid causing damages to the thread.
 3. Keep all hardware parts out of reach of children.

NOTE : THE LIST AND QUANTITY SHOWN ARE FOR 1 UNIT ASSEMBLY.

Tool needed : Screwdriver & Rubber Mallet (not provider).

PART LIST		
ITEM	DESCRIPTION	QTY
A	HEADBOARD	1 PC
B	FOOTBOARD	1 PC
C	SIDE RAIL	2 PCS
D	BED LEG	4 PCS
E	HANDLE	2 PCS
F	METAL FRAME	1 SET
G	PP TAPE	1 PC
H	GAS SPRING	2 PCS
I	METAL SUPPORT LEG	1 PC
J	HORIZONTAL SUPPORT WOOD	5 PCS
K	CENTER SUPPORT LEG	5 PCS
L	HEADBOARD SUPPORT WOOD	1 PC
M	FOOTBOARD SUPPORT WOOD	2 PCS
N	BOTTOM SUPPORT BOARD	4 PCS
O	BED SLAT	34 PCS
P	2 SMALL ANGLE	2 PCS
Q	HEADBOARD WINGS (L & R)	2 PCS

HARDWARE LIST		
ITEM	DESCRIPTION	QTY
1	JCBC BOLT M6 x 30mm 	5 PCS
2	JCBC BOLT M6 x 40mm 	8 PCS
3	JCBC BOLT M6 x 70mm 	6 PCS
4	JCBB BOLT M8 x 40mm 	16 PCS
5	WOOD SCREW M4 x 20mm 	8 PCS
6	WOOD DOWEL M8 x 30mm 	4 PCS
7	BED SLAT CENTER FITTER 	34 PCS
8	BED SLAT SIDE FITTER 	17 PCS
9	M4 ALLEN KEY (BALL SHAPE) 	1 PC
10	M5 ALLEN KEY (BALL SHAPE) 	1 PC
11	JCBC BOLT M6 x 40mm 	6 PCS
12	JCBB BOLT M8 x 70mm 	8 PCS
13	M6 FLAT WASHER 	12 PCS
14	M6 SPRING WASHER 	6 PCS
15	M8 FLAT WASHER 	20 PCS
16	M8 SPRING WASHER 	20 PCS
17	M6 HEX NUT 	6 PCS
18	M8 HEX NUT 	16 PCS
19	SPANNER (10mm) 	1 PC
20	SPANNER (13mm) 	1 PC
21	SPECIAL HEX NUT 	6 PCS
22	JCBC BOLT M8 x 20mm 	4 PCS
23	HANDLE SCREW M8 x 70mm 	2 PCS
24	M8 PLASTIC COVER 	8 PCS
25	PLASTIC WASHER 	4 PCS

STEP 1

Take out HEADBOARD WING (Q) from the HEABBOARD (A).

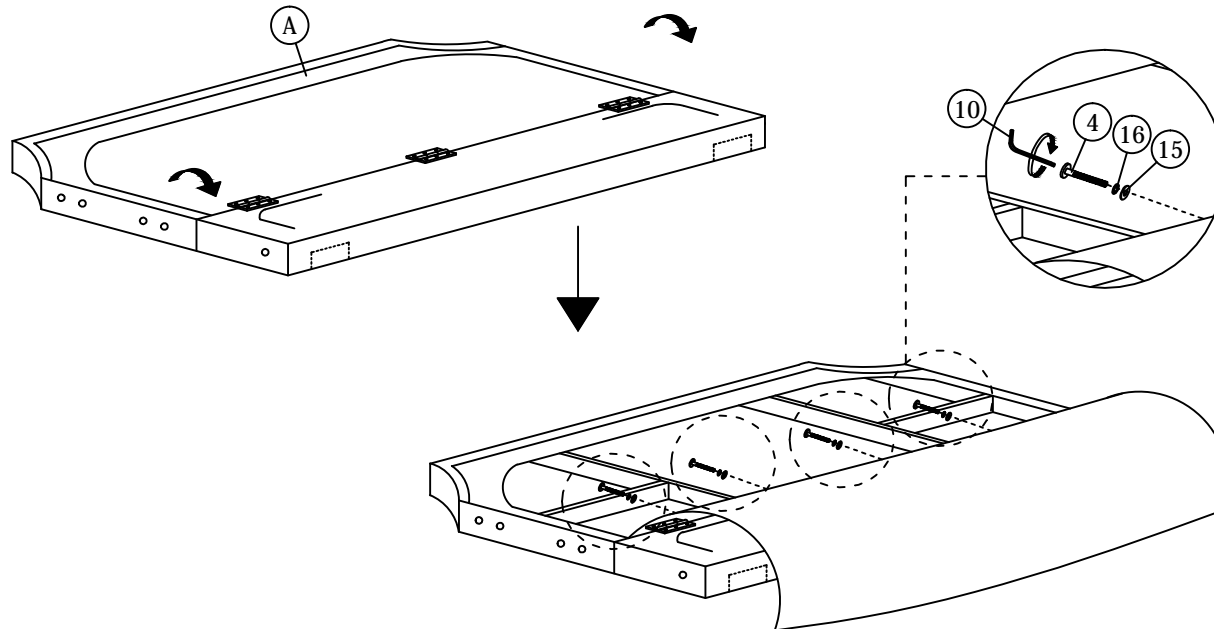

ASSEMBLY INSTRUCTIONS

STEP 2

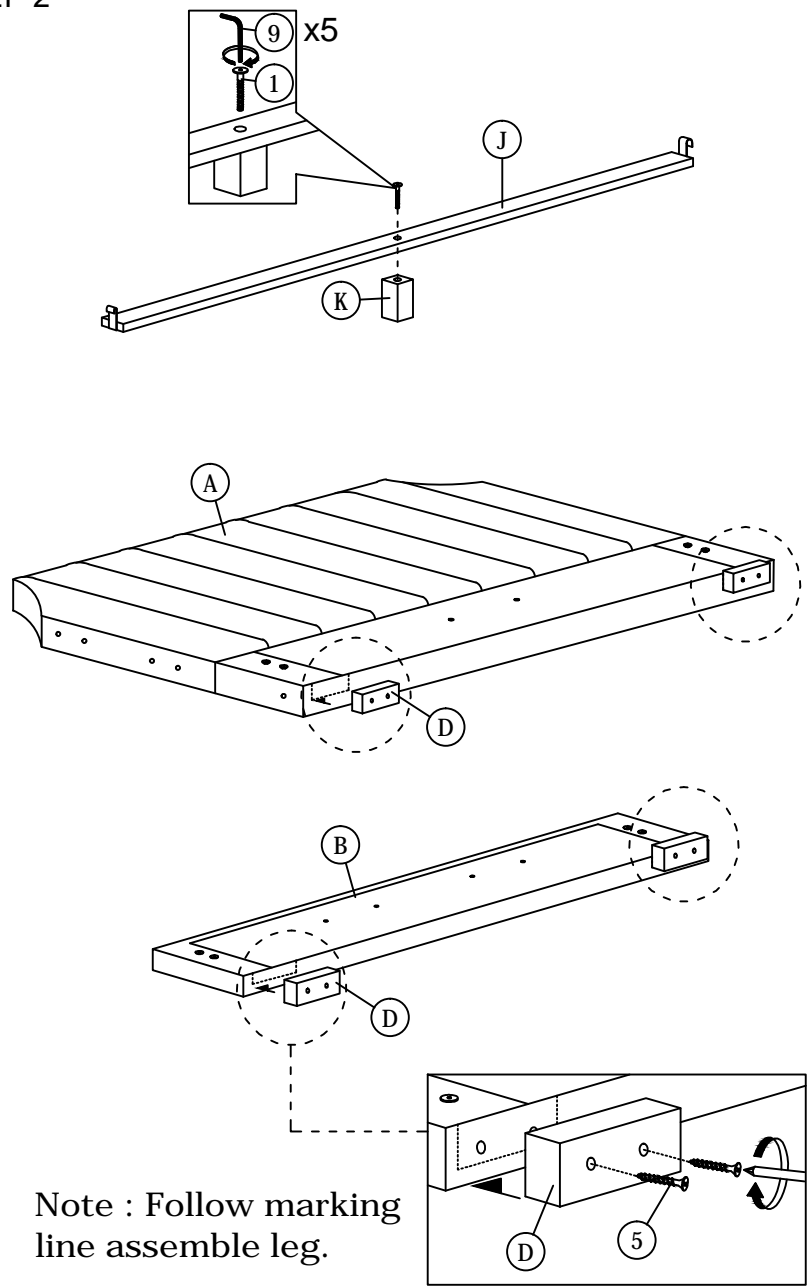

STEP 3

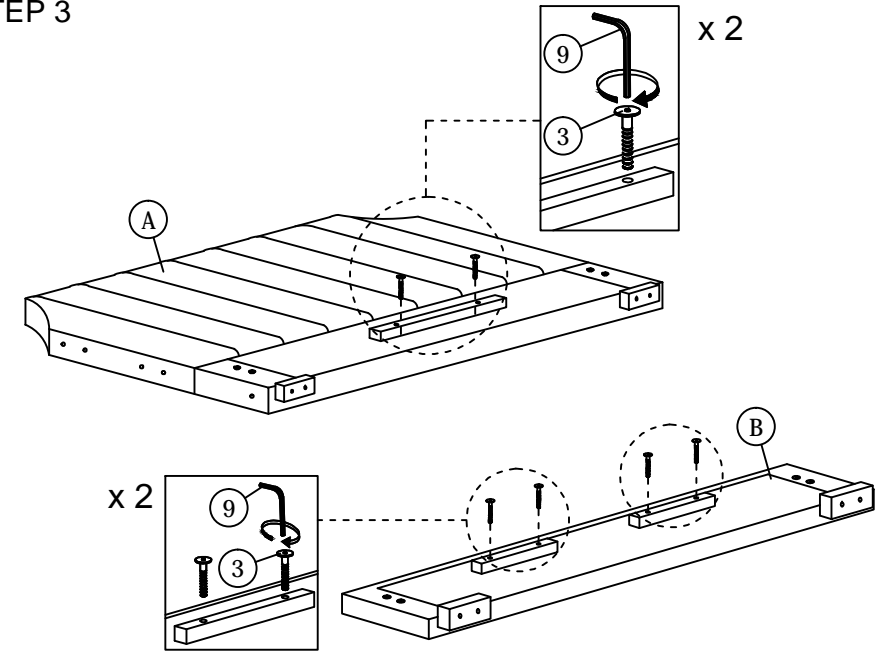

STEP 4

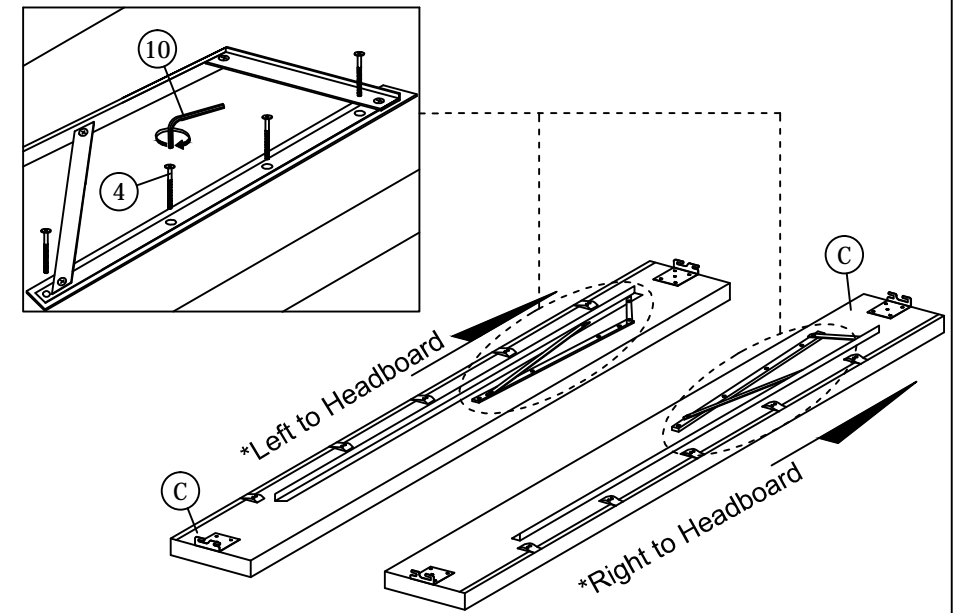

ASSEMBLY INSTRUCTIONS

STEP 5

STEP 5.1

Loosen the pre-inserted bolt on the Headboard & Footboard using Allen key ball shape (10).

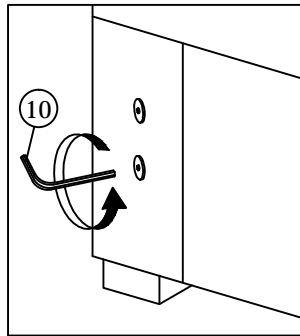

STEP 5.2

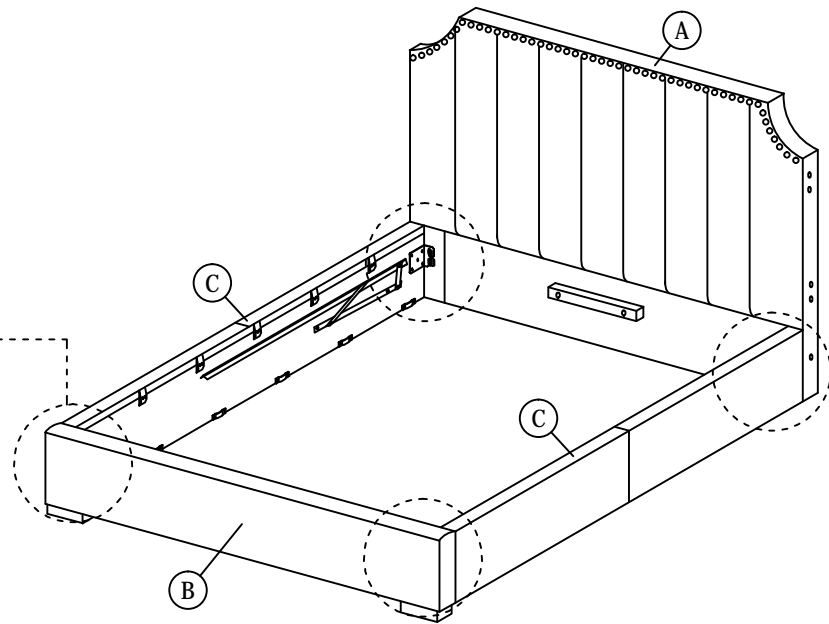
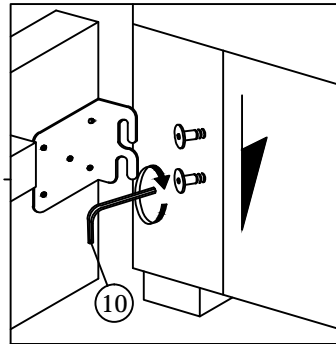

STEP 6

STEP 6.1

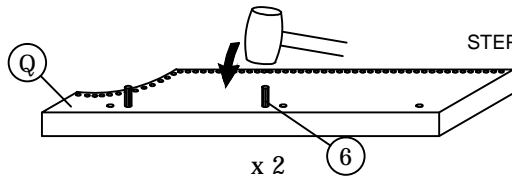

x 2 (6)

STEP 6.2

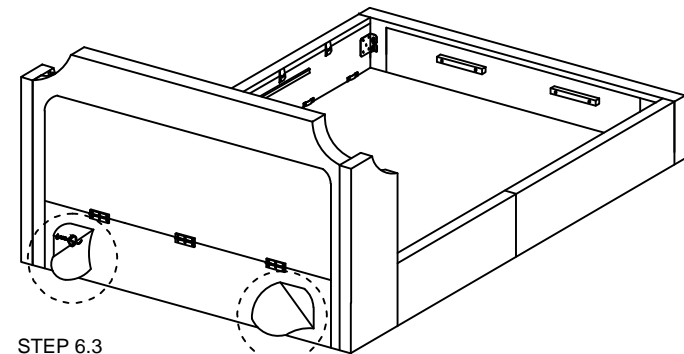
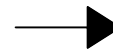
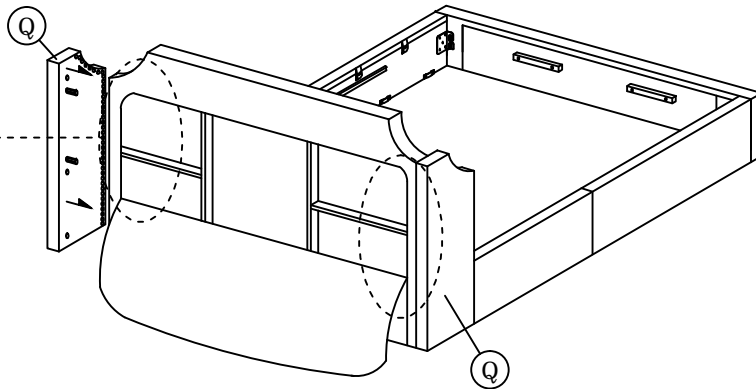
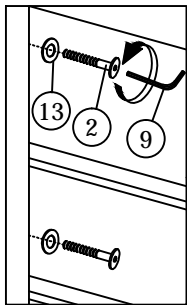

STEP 6.3

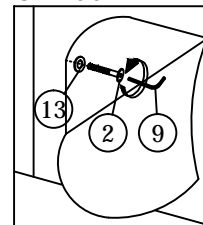

ASSEMBLY INSTRUCTIONS

STEP 7

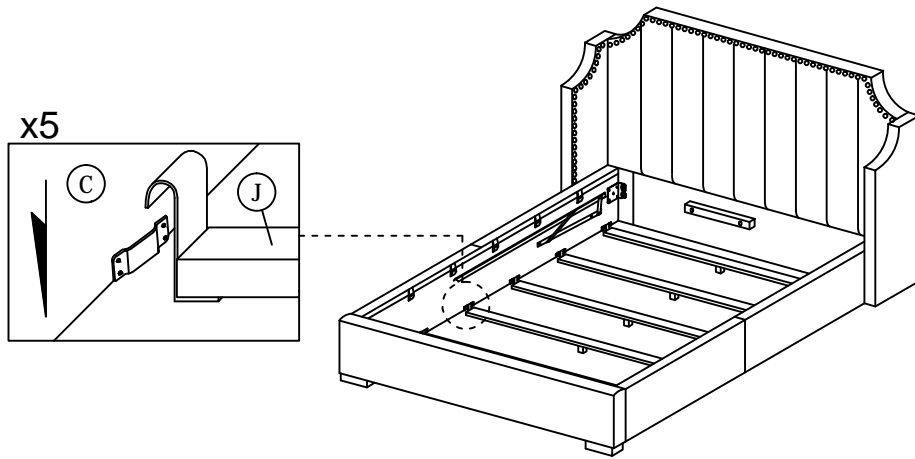

STEP 8

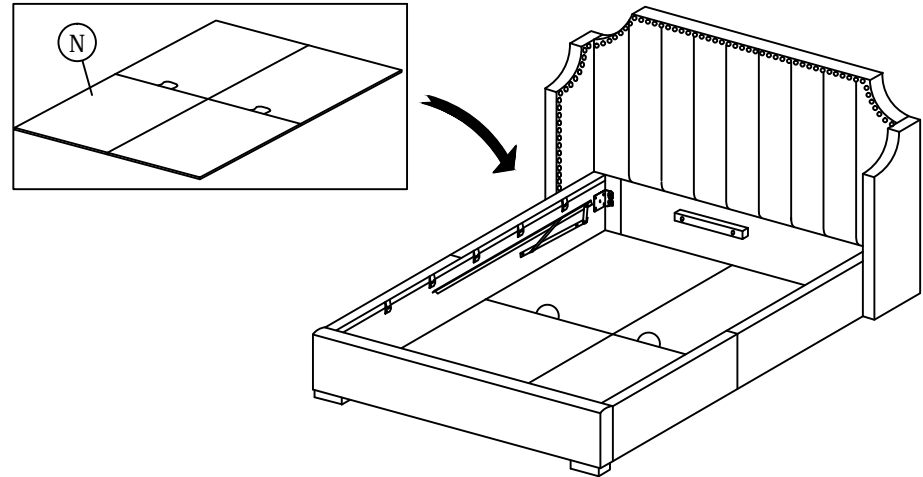

STEP 9

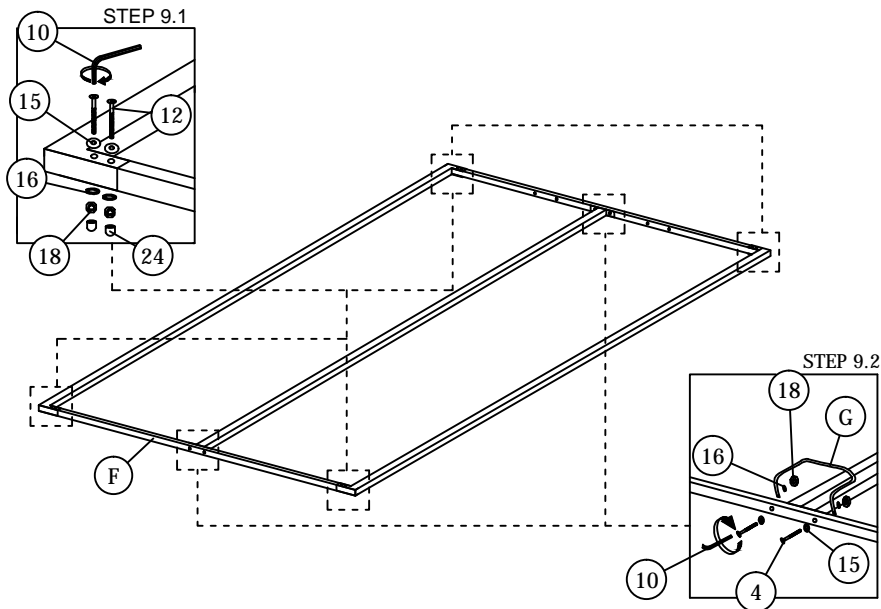

STEP 10

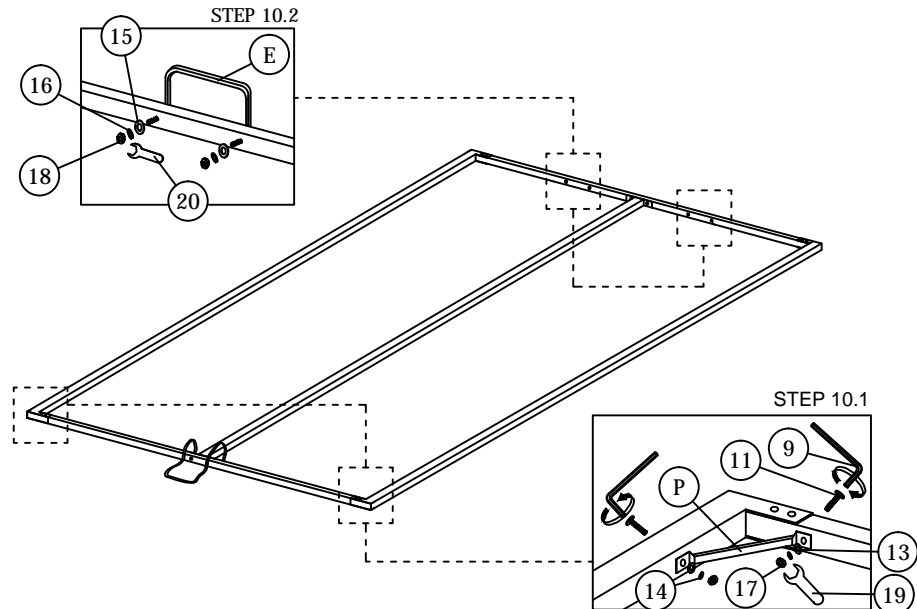

ASSEMBLY INSTRUCTIONS

STEP 11

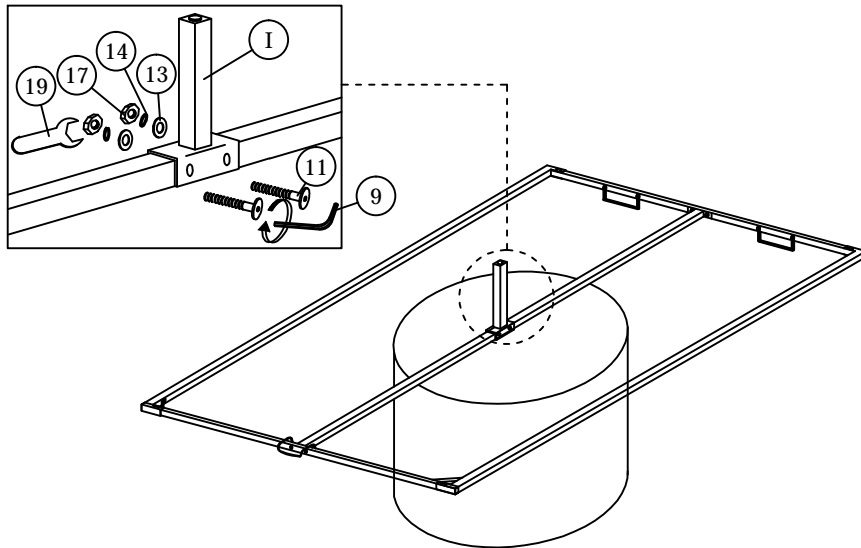

STEP 12

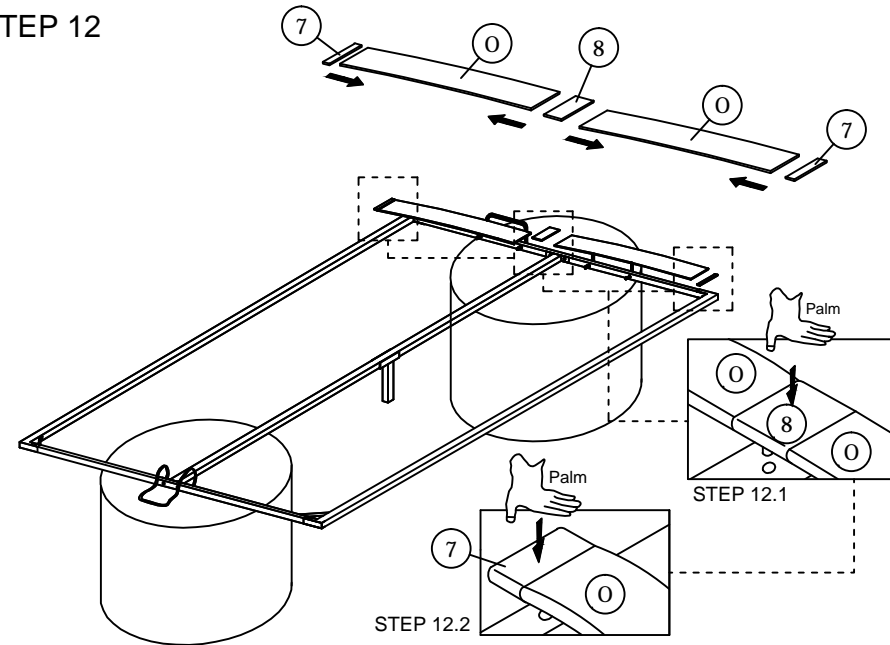

STEP 13

Attention :
A person need to hold up the metal frame from footboard side, and the other person assemble the gas spring (Item H).

Loosen the pre-inserted Special Hex Nut on the side rail metal (C) using Spanner 13mm (20).

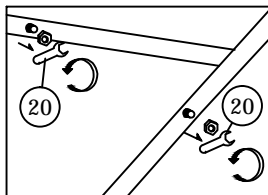

STEP 13.1

STEP 13.2

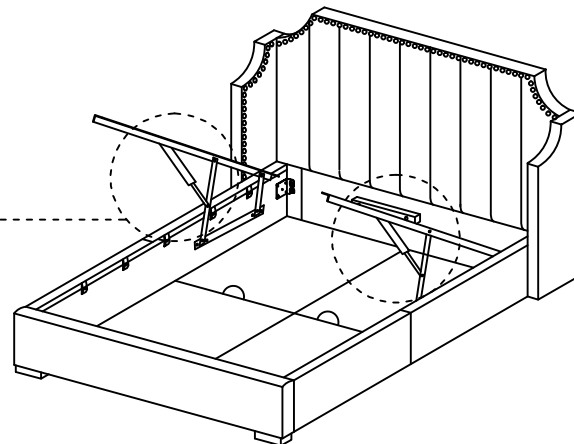
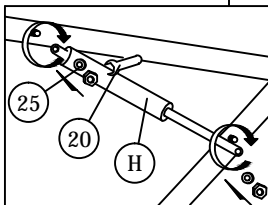

STEP 14

Note : This step requires two people.

STEP 14.1

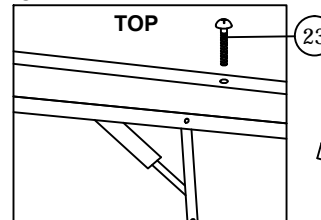

STEP 14.2

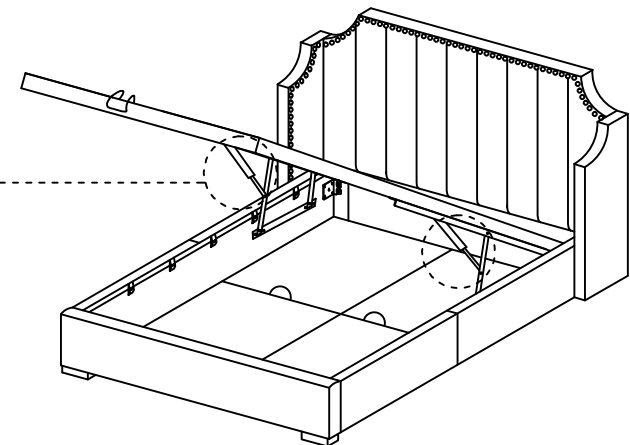
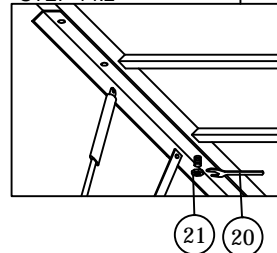

ASSEMBLY INSTRUCTIONS

STEP 15

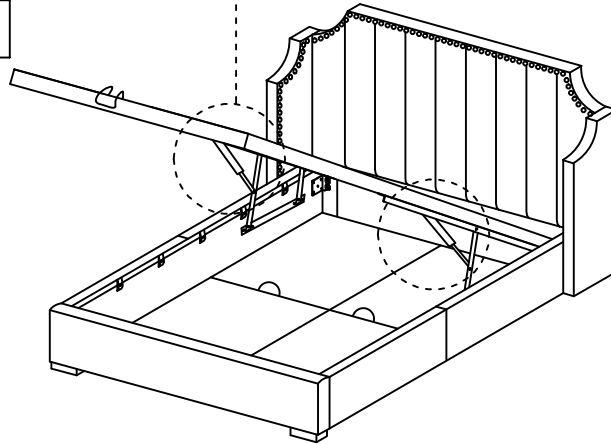
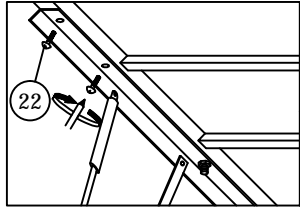

STEP 16

Attention :

1. This king size bed can't put more than 70kg mattress.

2. Place your mattress onto the bed frame BEFORE closing or this could results in damage to the bed (MATTRESS NOT INCLUDED) .

3. It is imperative that the bed is aligned squarely to prevent the frame from catching on and damaging the upholstered side rails
Please use extra caution when opening and closing the bed for the first few times.

Ensure a similar spacing on each side of the frame.

Ensure open and close the bed frame thru center of bed by using PP tape on center of metal frame.

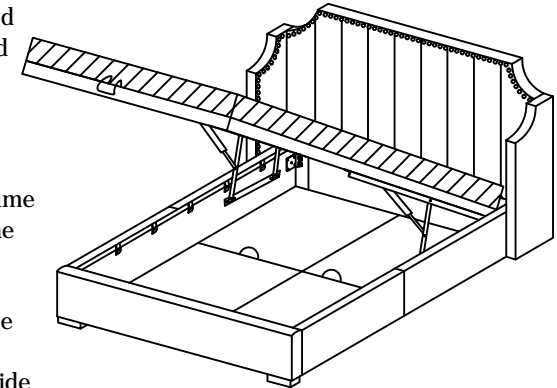

STEP 17

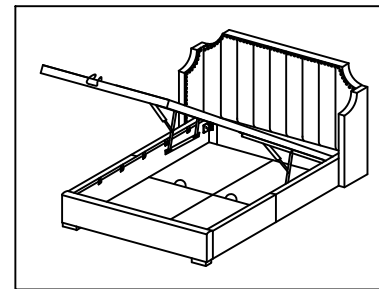
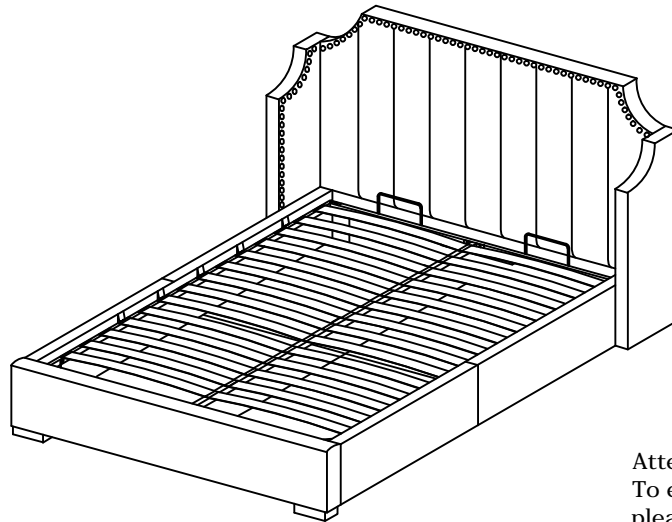

Attention :

To ensure your bed frame remains in optimum condition, please periodically check all the screw and re-tightening if necessary.