

Montageanleitung | Instructionsde montage Assembly Instructions | Instruccionesde montaje

SKUNUMBER:
N636P414885/N636P414886

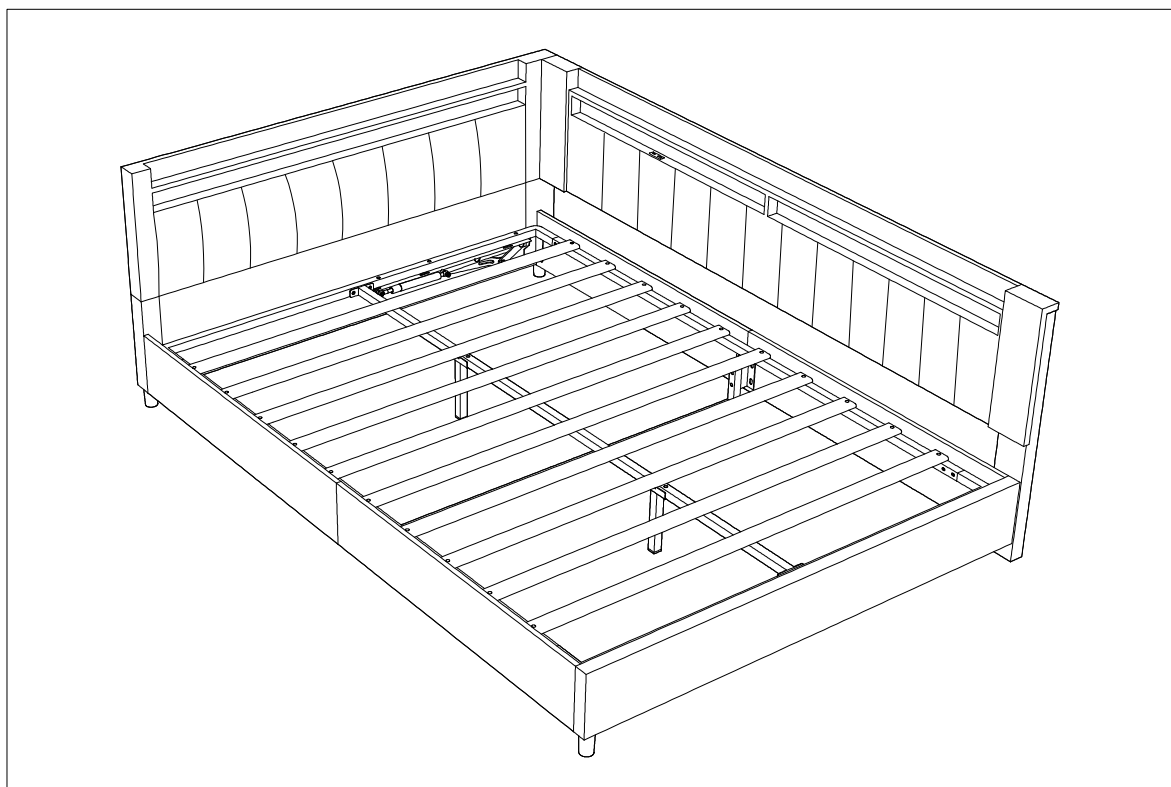

● Unser Produkt wird Ihnen in 2 Paketen geliefert. Die Lieferzeiten dieser 2 Pakete können abweichen, bitte haben Sie etwas Geduld und vielen Dank für Ihr Verständnis.

● Our product will be delivered to you in 2 packages. The delivery times of these 2 packages may differ, please be patient and thank you for your understanding.

● Notre produit vous sera livré en 2 colis. Les délais de livraison de ces 2 colis peuvent différer, soyez patient et merci pour votre compréhension.



DE: Vor dem Einbau die Schrauben in die Löcher stecken und festziehen, aber nicht bis 100%, 70% bis 80% anziehen reicht aus. Schließlich, nachdem alle Schrauben installiert sind, ziehen Sie alle Schrauben auf 100%. Wenn Sie auf diese Probleme stoßen, wie z. B. Fehlausrichtung der Löcher oder Unfähigkeit, bestimmte Teile zu installieren, überprüfen Sie bitte, ob die Schrauben korrekt verwendet werden und passen Sie die Dichtigkeit der Schrauben an.

UK: Before installation, insert the screws into the holes and tighten them, but do not tighten them to 100%, 70% to 80% is sufficient. Finally, after all screws are installed, tighten all screws to 100%. If you encounter these issues, such as if the holes cannot be aligned or some parts cannot be installed, please check if the screws are used correctly and adjust the tightness of the screws.

FR: Insérer la vis dans le trou avant la fin de l'assemblage, serrer la vis, mais ne pas serrer à 100%, 70% ~ 80% est correct. Enfin, une fois que toutes les vis sont bien serrées, toutes les vis sont serrées à 100%. Si vous rencontrez ces problèmes, par exemple si les trous ne sont pas alignés ou si certaines pièces ne peuvent pas être montées, vérifiez que les vis sont utilisées correctement et Ajustez leur serrage.

English

IMPORTANT FOR GAS LIFT BEDS&MAINTAINANCE

- Please place the mattress on top of the bed frame.
- Please do not pull on the strap handles.
- Please press heavily to release the compressed gas.
- Periodically check all screw & fixings to ensure they are secure.
- When moving your product, carefully lift into place.
- Wipe clean with a slightly damp cloth- please do not use abrasive chemicals or bleach.
- Do NOT allow children to operate the lift mechanism.
- Do NOT allow children near the lift base when operating the mechanism.
- Do NOT stand inside the bed or the internal storage base.
- Do NOT overload the internal storage base.
- DO NOT jump on the product or any of its parts.

Deutsch

WICHTIG FÜR GASLIFT-BETTEN&WARTUNG

- Bitte legen Sie die Matratze oben auf den Bettrahmen.
- Bitte ziehen Sie nicht an den Gurtgriffen.
- Bitte drücken Sie kräftig, um das komprimierte Gas freizusetzen.
- Überprüfen Sie regelmäßig alle Schrauben und Befestigungen, um sicherzustellen, dass sie sicher sind.
- Wenn Sie Ihr Produkt bewegen, heben Sie es vorsichtig an seinen Platz.
- Mit einem leicht feuchten Tuch abwischen - bitte keine scheuernden Chemikalien oder Bleichmittel verwenden.
- Erlauben Sie Kindern NICHT, den Hebemechanismus zu bedienen.
- Lassen Sie Kinder NICHT in die Nähe des Liftsockels, wenn Sie den Mechanismus bedienen.
- Stellen Sie sich NICHT in das Bett oder in die Innenablage.
- Überlasten Sie den internen Liftsockel NICHT.
- Springen Sie NICHT auf das Produkt oder eines seiner Teile.

Français

IMPORTANT POUR LES LITS À RELEVAGE DE GAZ&MAINTENANCE

- Veuillez placer le matelas sur le dessus du cadre de lit.
- Ne tirez pas sur les poignées de la sangle.
- Appuyez fortement pour libérer le gaz comprimé.
- Vérifiez régulièrement que toutes les vis et fixations sont bien en place.
- Lorsque vous déplacez votre produit, soulevez-le avec précaution pour le mettre en place.
- Nettoyez avec un chiffon légèrement humide - n'utilisez pas de produits chimiques abrasifs ou d'eau de Javel.
- Ne laissez pas les enfants utiliser le mécanisme de levage.
- Ne laissez pas les enfants s'approcher de la base de levage lorsqu'ils actionnent le mécanisme.
- Ne vous tenez PAS à l'intérieur du lit ou de la base de stockage interne.
- Ne surchargez pas la base de stockage interne.
- Ne pas sauter sur le produit ou l'une de ses parties.

Italiano

IMPORTANTE PER I LETTI CON SOLLEVAMENTO A GAS E LA MANUTENZIONE

- Posizionare il materasso sopra la struttura del letto.
- Non tirare le maniglie della cinghia.
- Premere con forza per rilasciare il gas compresso.
- Controllare periodicamente tutte le viti e i fissaggi per assicurarsi che siano saldi.
- Quando si sposta il prodotto, sollevarlo con cautela.
- Pulire con un panno leggermente umido, senza usare prodotti chimici abrasivi o candeggina.
- NON permettere ai bambini di azionare il meccanismo di sollevamento.
- NON permettere ai bambini di avvicinarsi alla base di sollevamento quando si aziona il meccanismo.
- NON sostare all'interno del letto o della base di contenimento interna.
- NON sovraccaricare la base di contenimento interna.
- NON saltare sul prodotto o sulle sue parti.

Español

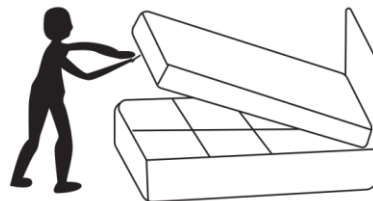
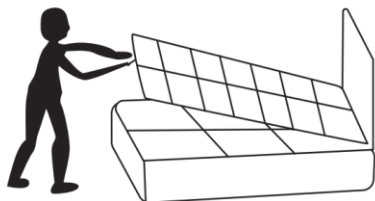

IMPORTANTE PARA LAS CAMAS ELEVADORAS DE GAS&MANTENIMIENTO

- Coloque el colchón sobre el somier.
- No tire de las asas de la correa.
- Presione con fuerza para liberar el gas comprimido.
- Compruebe periódicamente que todos los tornillos y fijaciones estén bien sujetos.
- Al mover el producto, levántelo con cuidado para colocarlo en su sitio.
- Limpie con un paño ligeramente humedecido; no utilice productos químicos abrasivos ni lejía.
- NO permita que los niños accionen el mecanismo de elevación.
- NO permita que los niños se acerquen a la base elevadora cuando accionen el mecanismo.
- NO se ponga de pie dentro de la cama o de la base de almacenamiento interna.
- NO sobrecargue el somier.
- NO salte sobre el producto ni sobre ninguna de sus piezas.

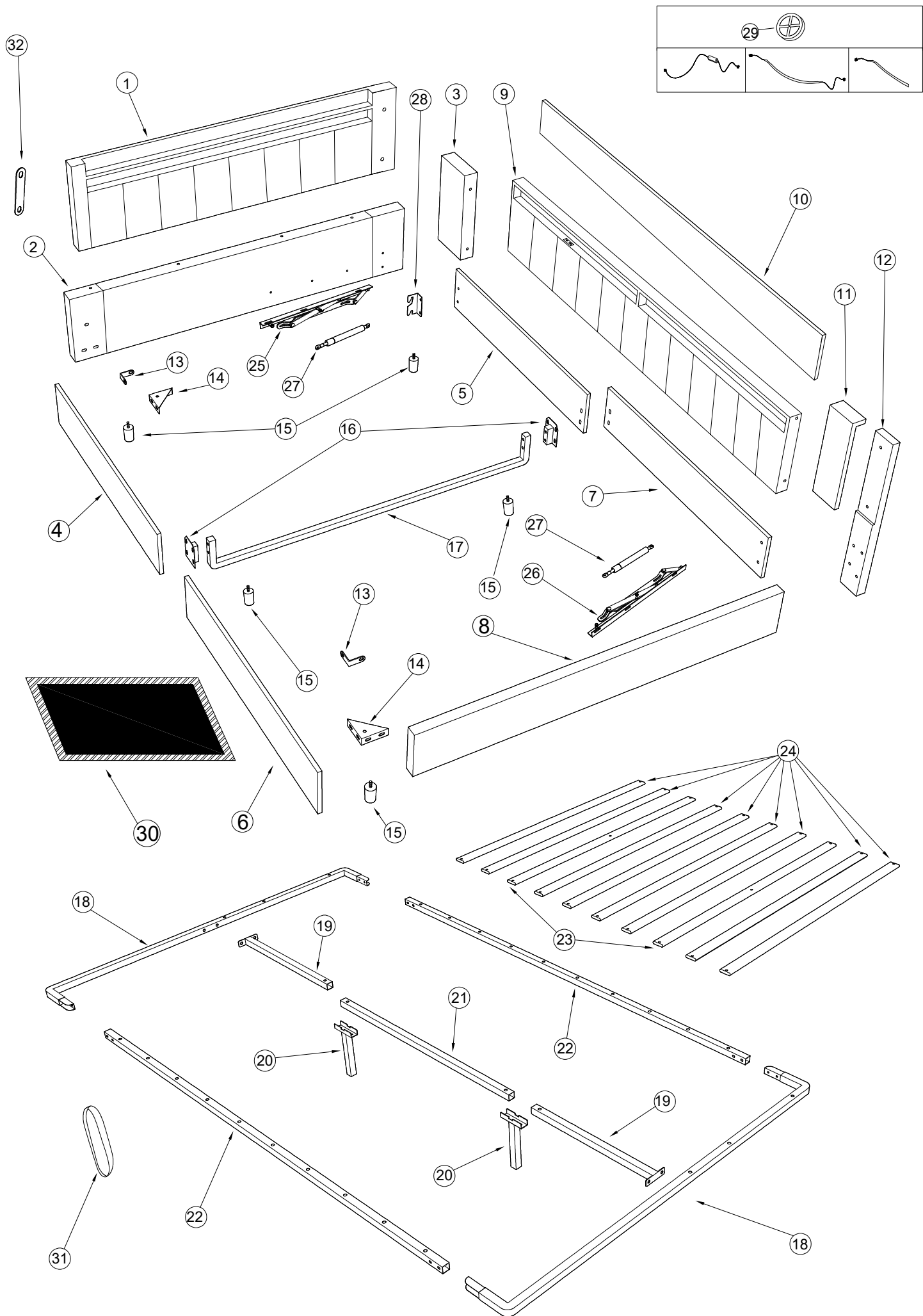

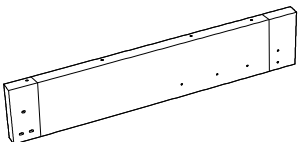
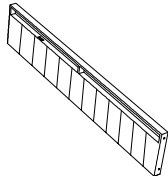
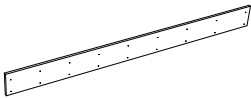
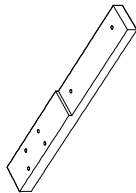
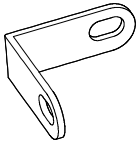
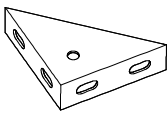
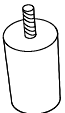
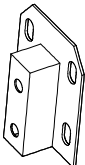
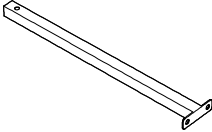
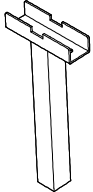
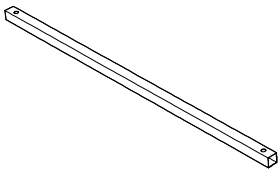
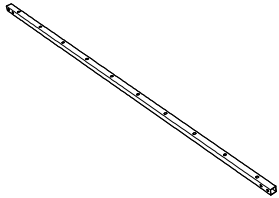
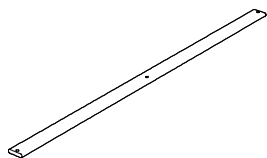
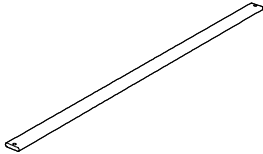
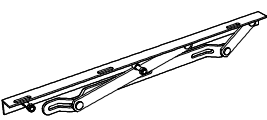
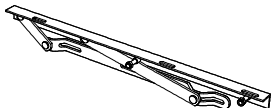
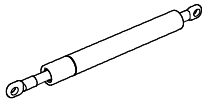

Part List/ Teileliste/ Liste des pièces
N636P414885





2		x1	9		x1
10		x1	12		x1
13		x2	14		x2
15		x5	16		x2
19		x2	20		x2
21		x1	22		x2
23		x2	24		x8
25		x1	26		x1
27		x2	28		x1

Part List/ Teileliste/ Liste des pièces
N636P414885

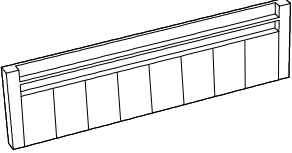
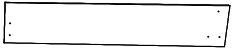
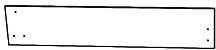
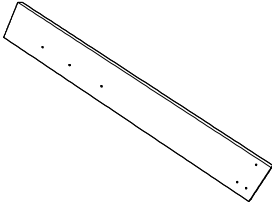
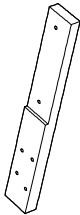
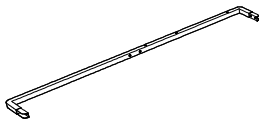
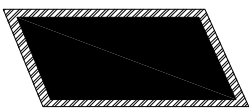
32		×1
----	---	----

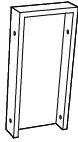
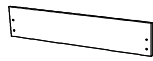
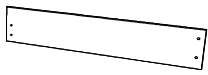

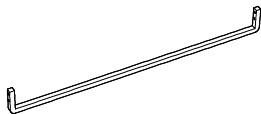
Part List/ Teileliste/ Liste des pièces
N636P414886



1		×1
4		×1
6		×1
8		×1
12		×1
18		×2
30		×1

3		×1
5		×1
7		×1
11		×1
17		×1
29		×1
31		×1

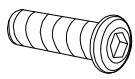
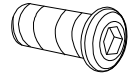
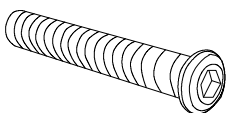
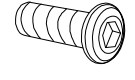
Hardware List/ Hardware-Liste/ Liste du matériel

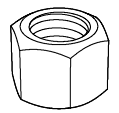
N636P414885

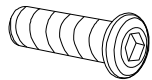
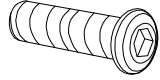
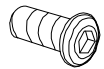
<p>(A)</p>	<p>M8*35MM</p> 	<p>×20</p>
<p>(C)</p>	<p>M8*20MM</p> 	<p>×36</p>
<p>(E)</p>	<p>M8*65MM</p> 	<p>×2</p>
<p>(G)</p>	<p>M6*25MM</p> 	<p>×20</p>
<p>(I)</p>		<p>×1</p>
<p>(K)</p>		<p>×6</p>

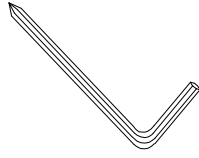
<p>(B)</p>	<p>M8*40MM</p> 	<p>×6</p>
<p>(D)</p>	<p>M8*47MM</p> 	<p>×4</p>
<p>(F)</p>	<p>M6*14MM</p> 	<p>×8</p>
<p>(H)</p>	<p>φ3*25MM</p> 	<p>×21</p>
<p>(J)</p>		<p>×1</p>

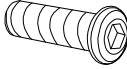
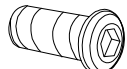
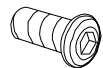
A	M8*35MM 	×20
C	M8*20MM 	×36
F	M6*14MM 	×8

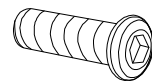
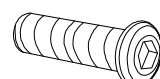
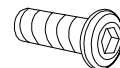
B	M8*40MM 	×6
D	M8*47MM 	×4
G	M6*25MM 	×20

DE:Bitte beachten Sie, dass die Formen der Schrauben A und B und C und D und F und G ähnlich sind. Bitte installieren Sie entsprechend der Anleitung und unterscheiden Sie sie!

UK:Please note that the shapes of screws A and B and C and D and F and G are similar. Please install according to the instructions and distinguish them!

FR:Notez que les vis A et B et C et D et F et G ont des formes similaires. Veuillez les installer en suivant les instructions pour les séparer!

1

$\phi 3 \times 25 \text{MM}$
H×21PCS

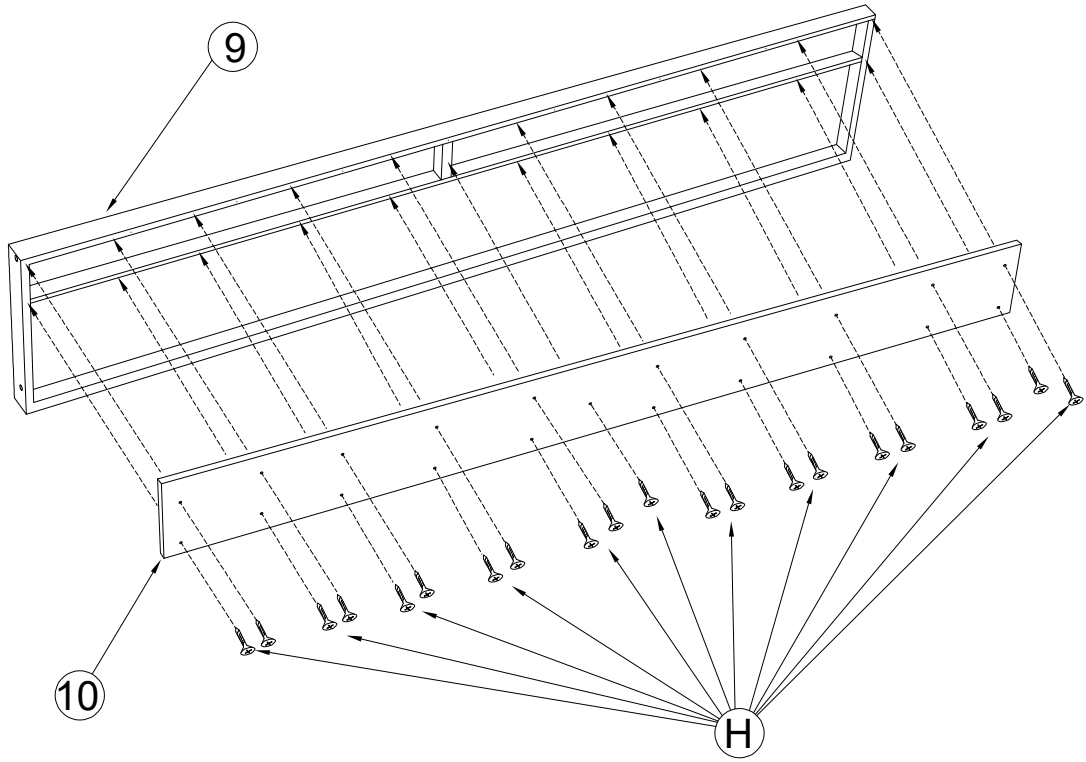

2

M8×35MM
A×4PCS

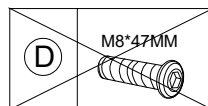
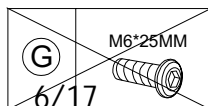
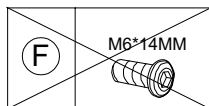
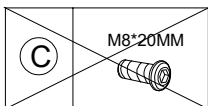
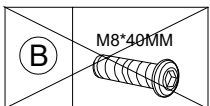
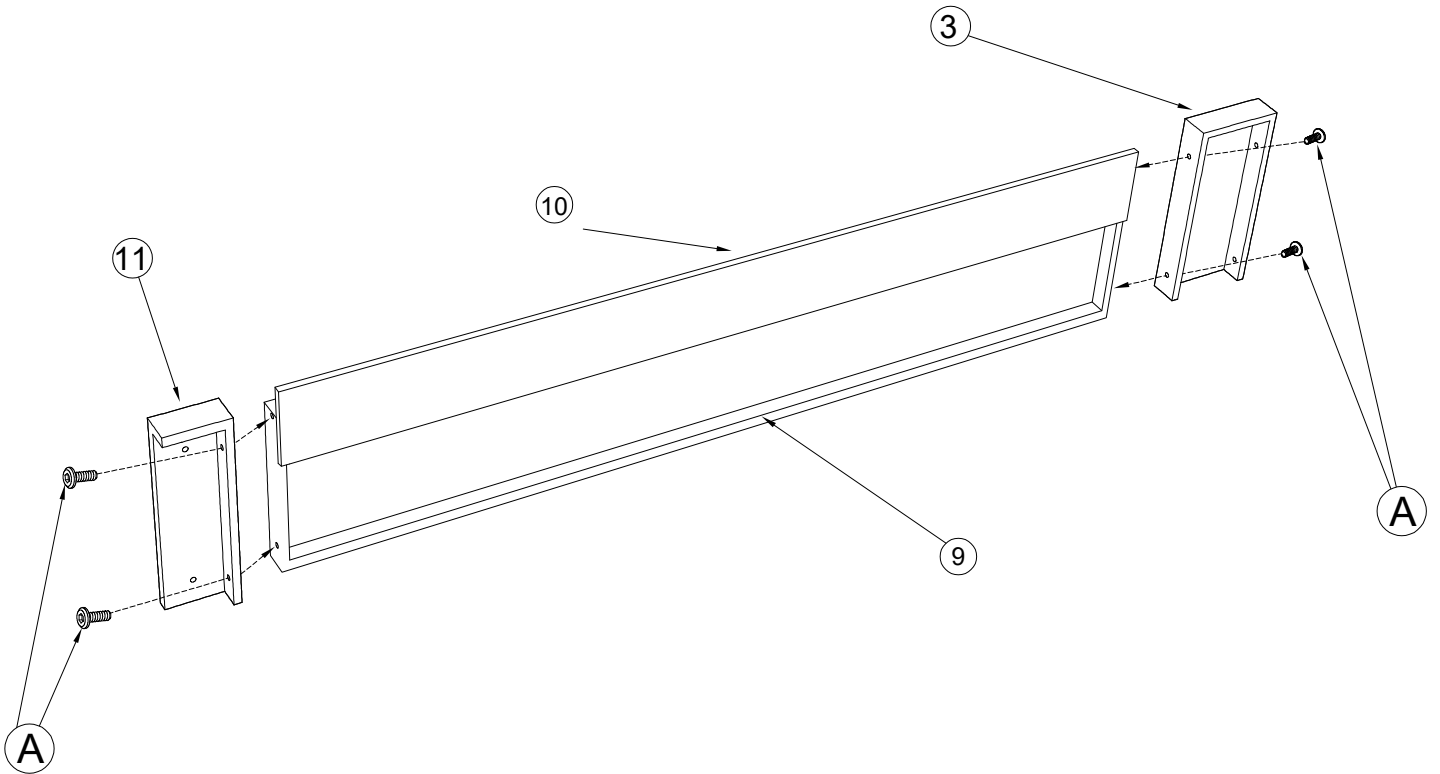

3

M8*47MM
D×2PCS

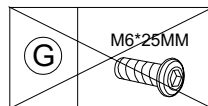
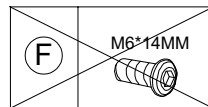
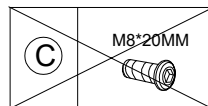
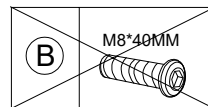
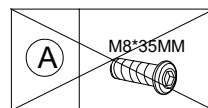
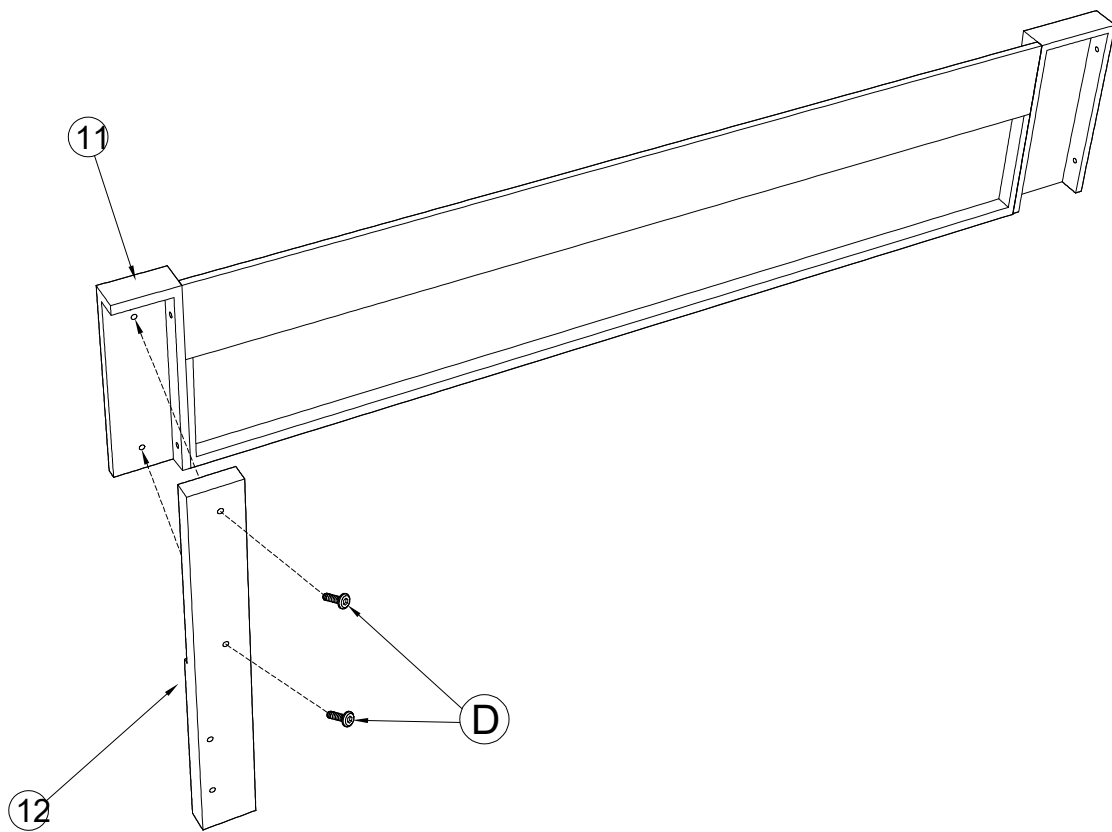

4

M8*35MM A×4PCS
M8*20MM C×5PCS

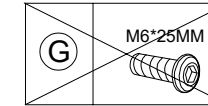
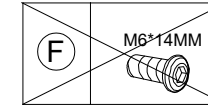
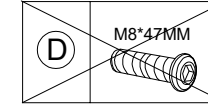
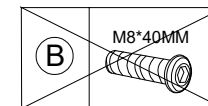
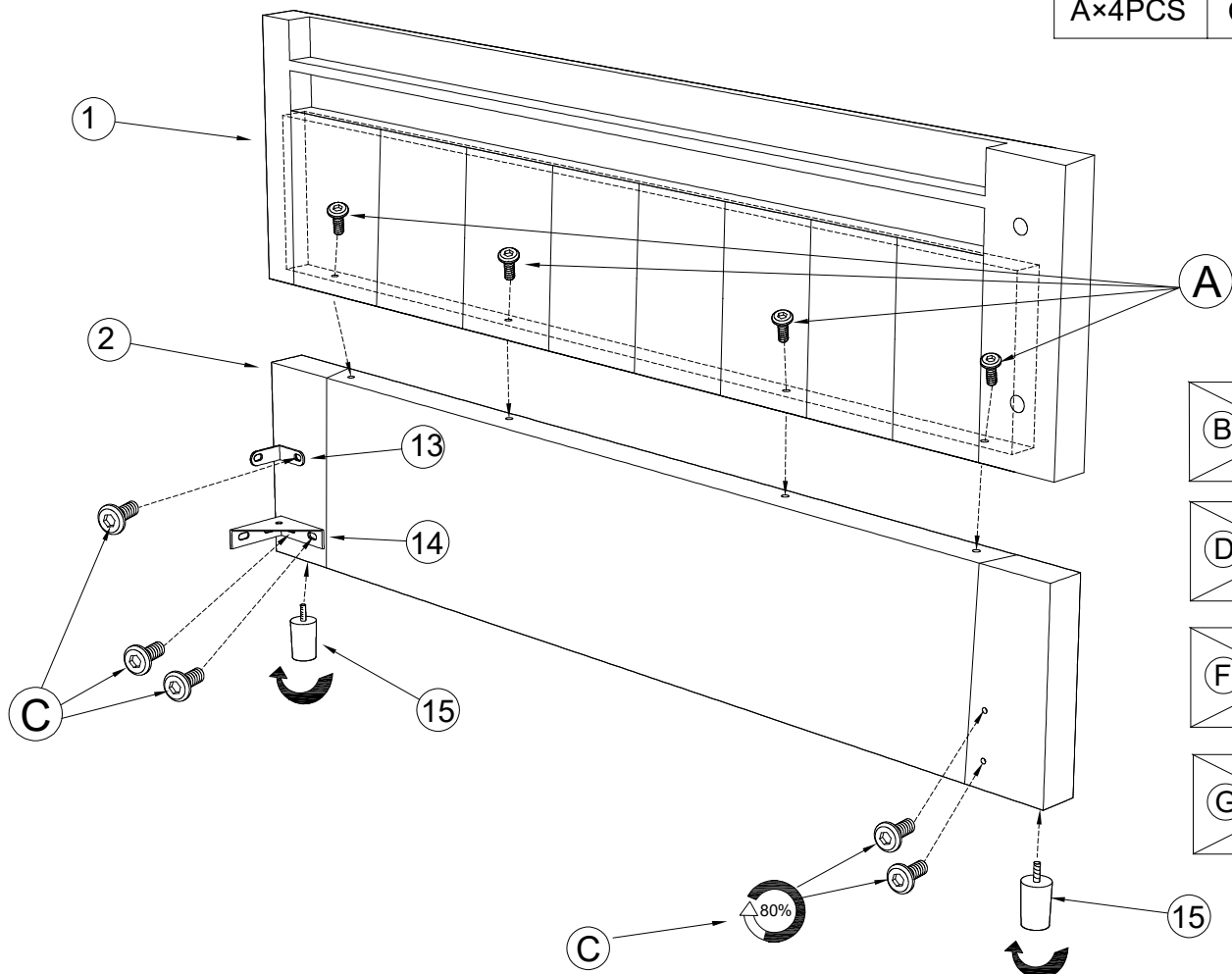

5

M8*20MM
C×3PCS

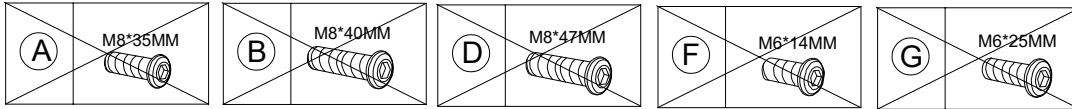
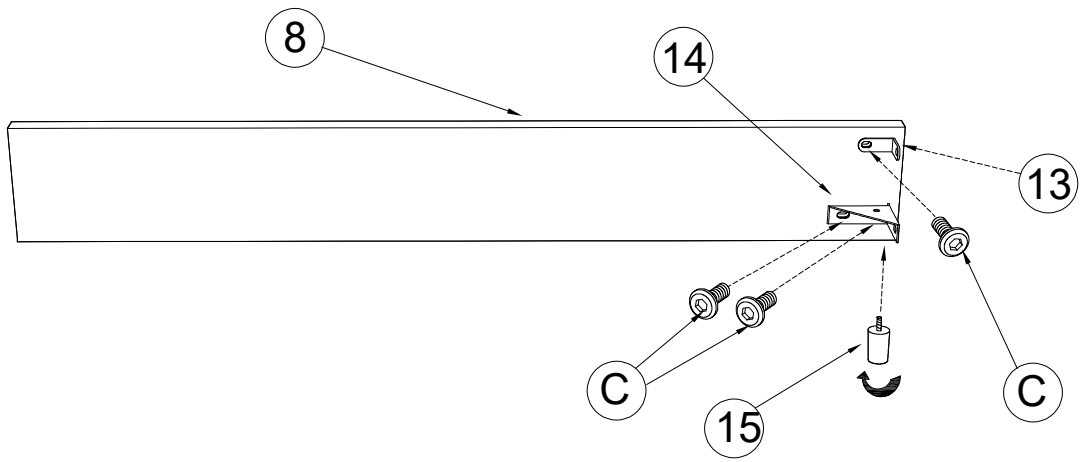

6

M8*20MM
C×10PCS

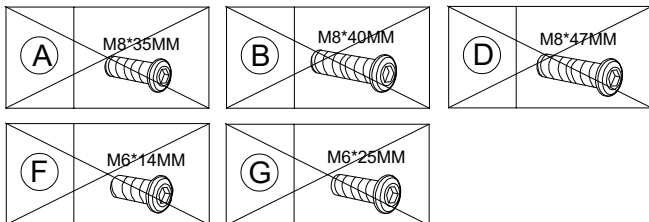
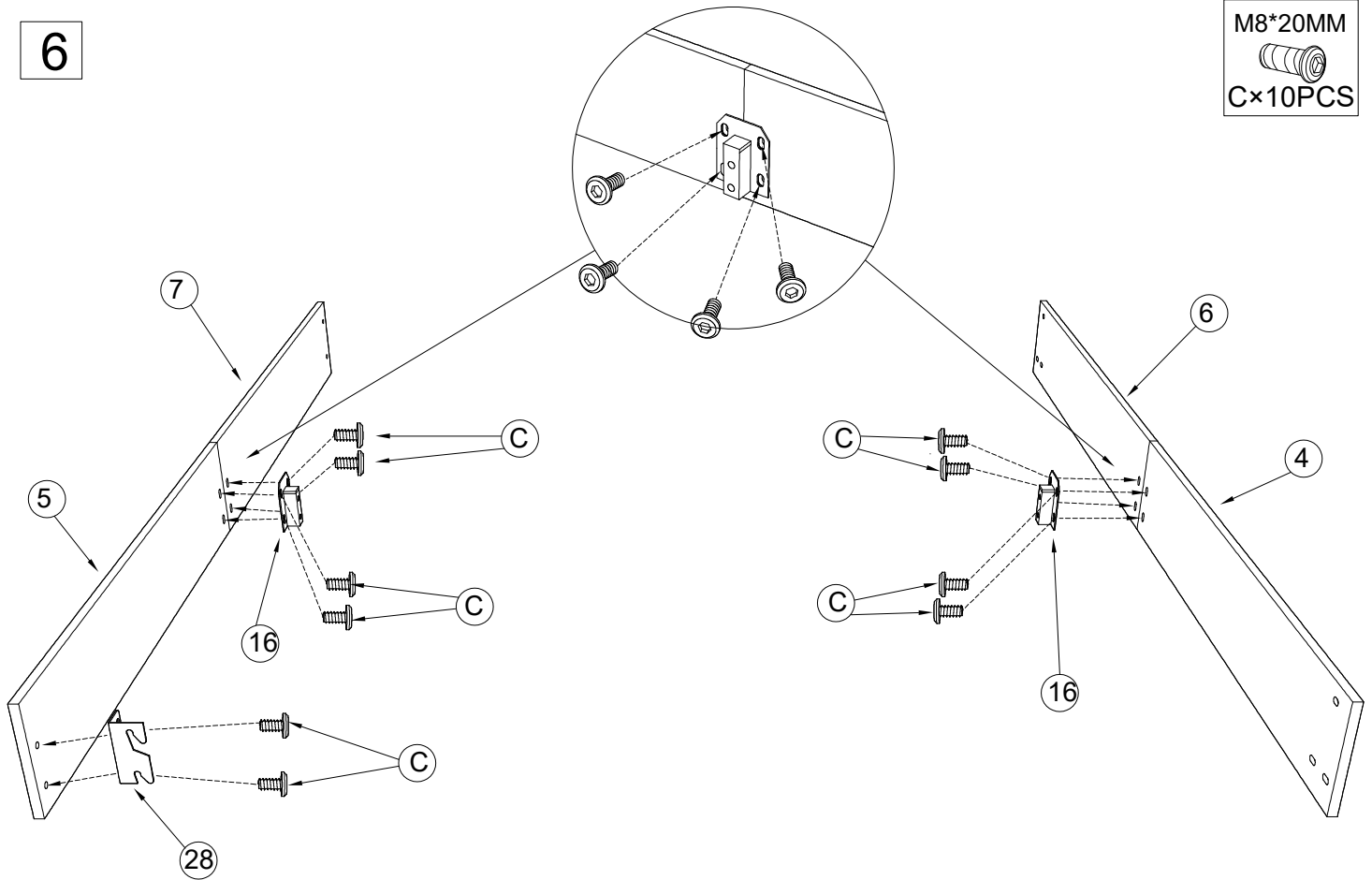

M8*35MM



A*4PCS

M8*20MM



C*8PCS

M8*65MM



E*2PCS

7

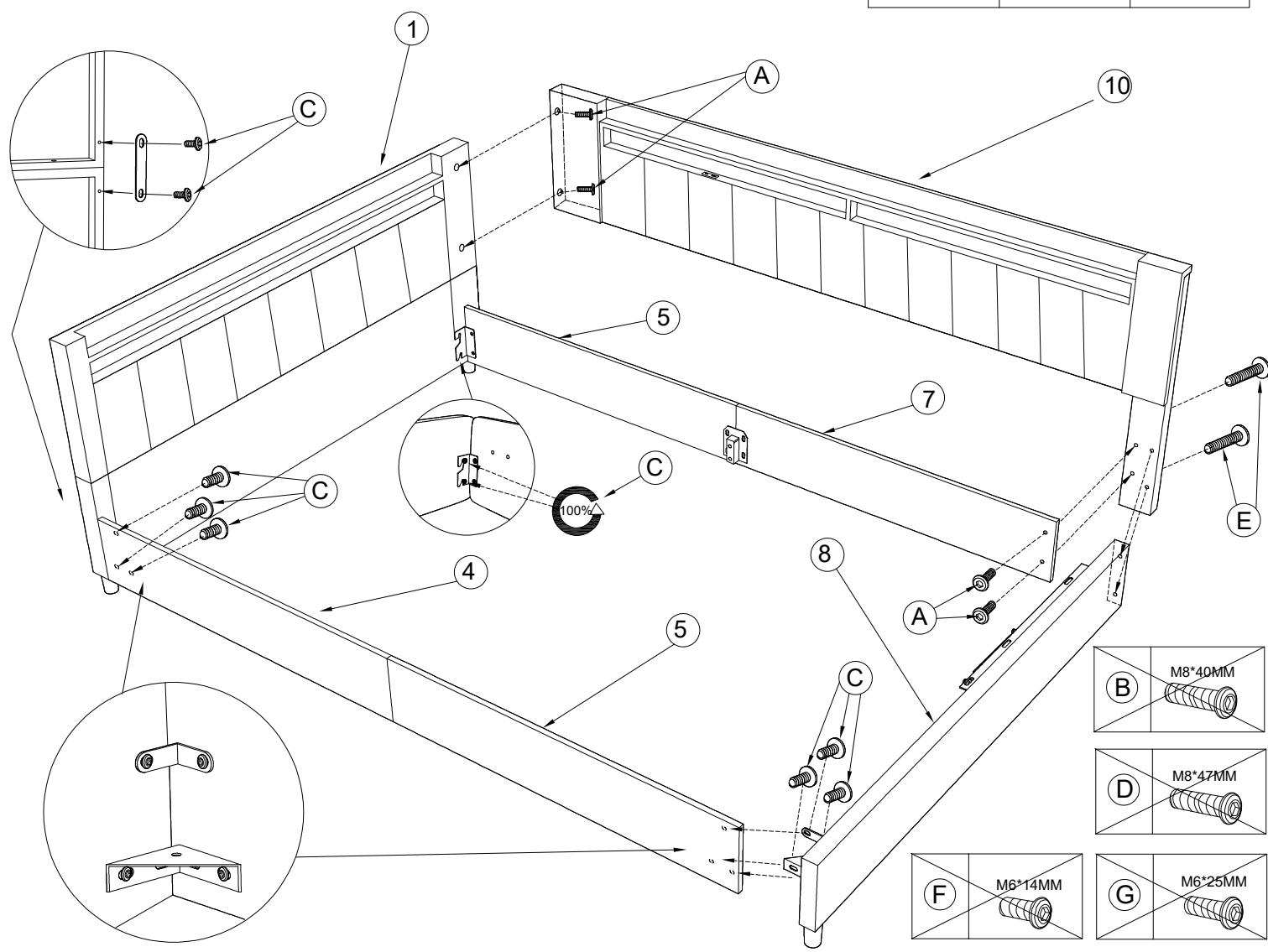

M8*35MM



A*4PCS

M8*20MM



C*4PCS

M6*14MM



F*8PCS

8

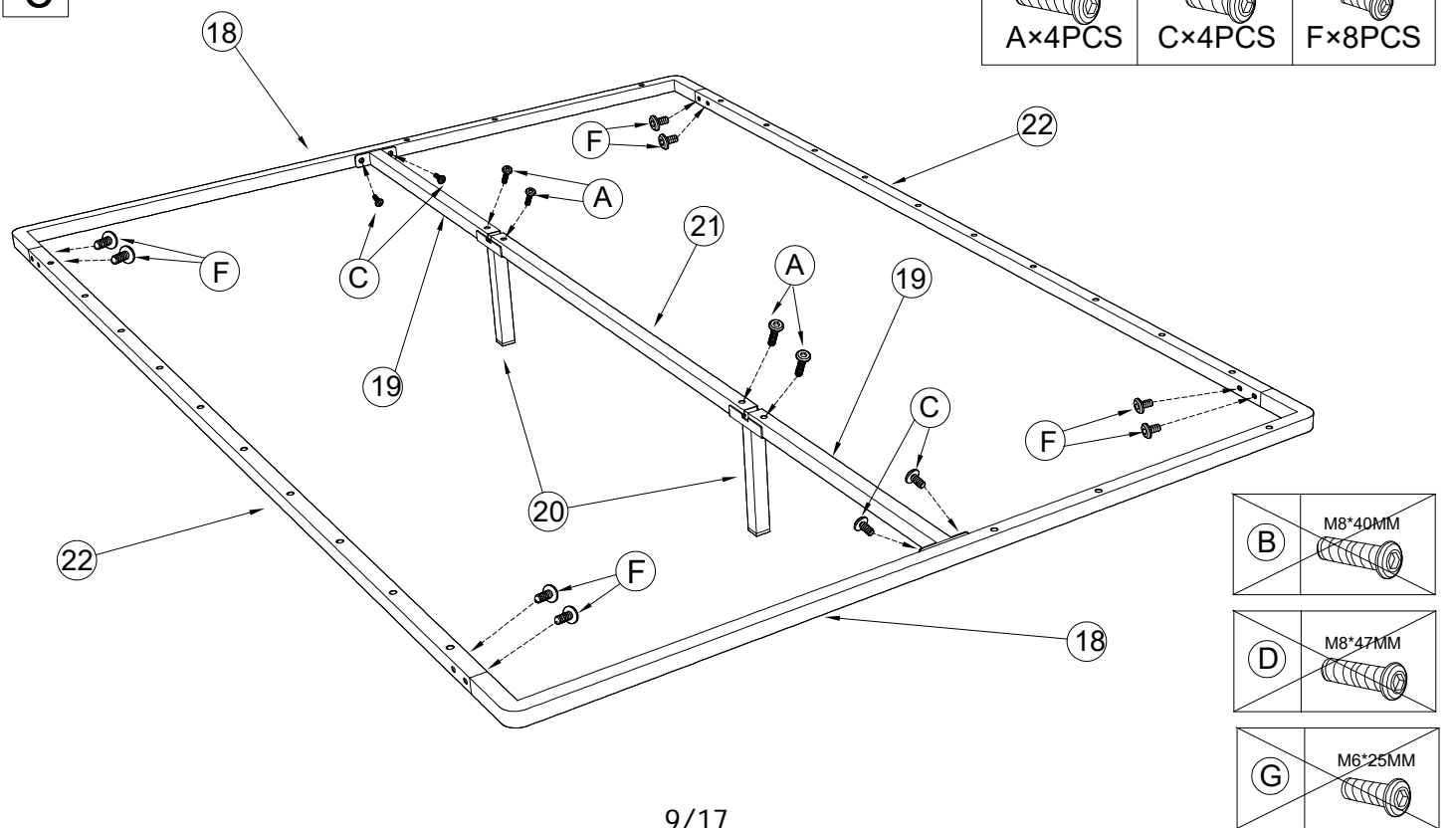

9

1

10

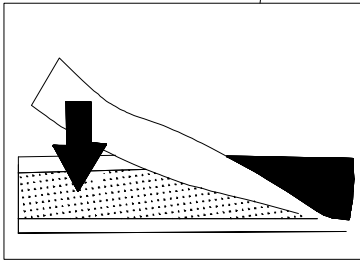
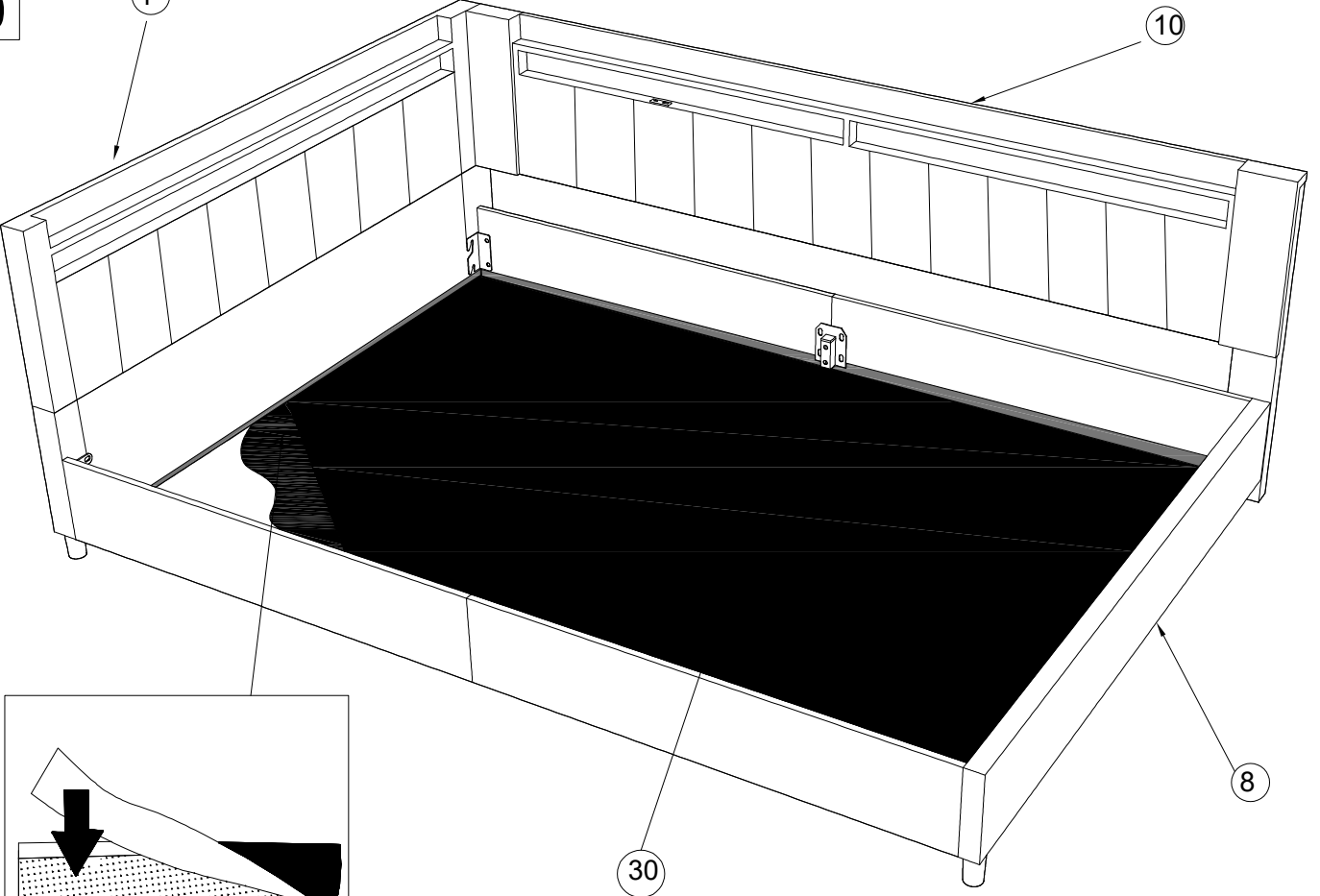

30

8

10

M8*20MM

 Cx3PCS

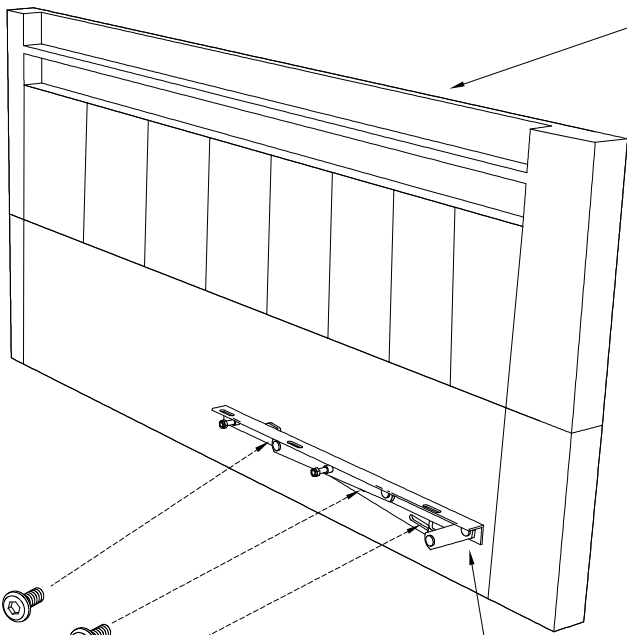
1

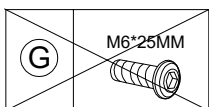
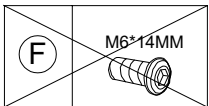
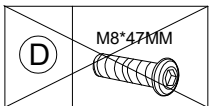
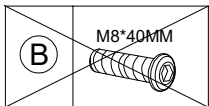
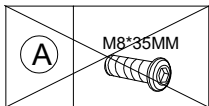

C

25



11

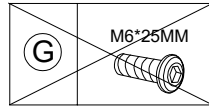
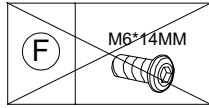
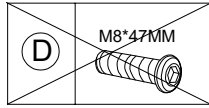
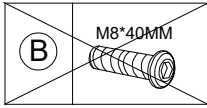
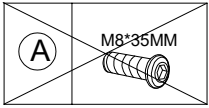
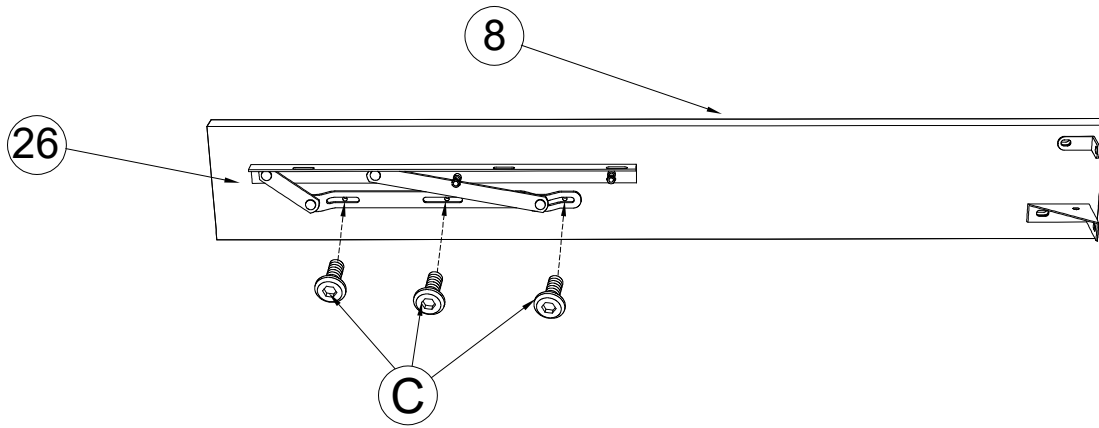

M8*20MM
C×3PCS

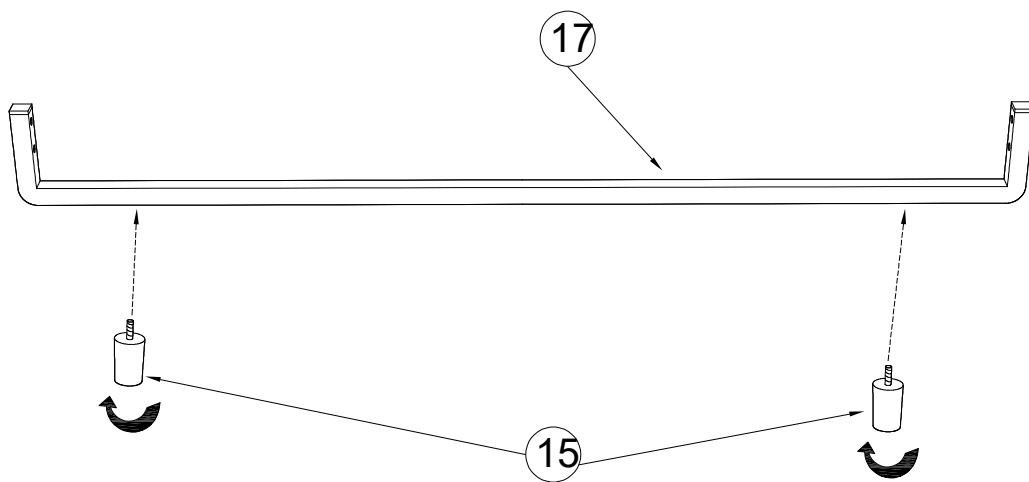

12

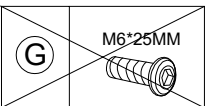
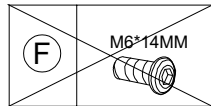
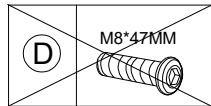
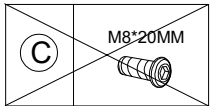
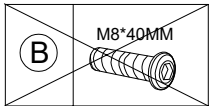
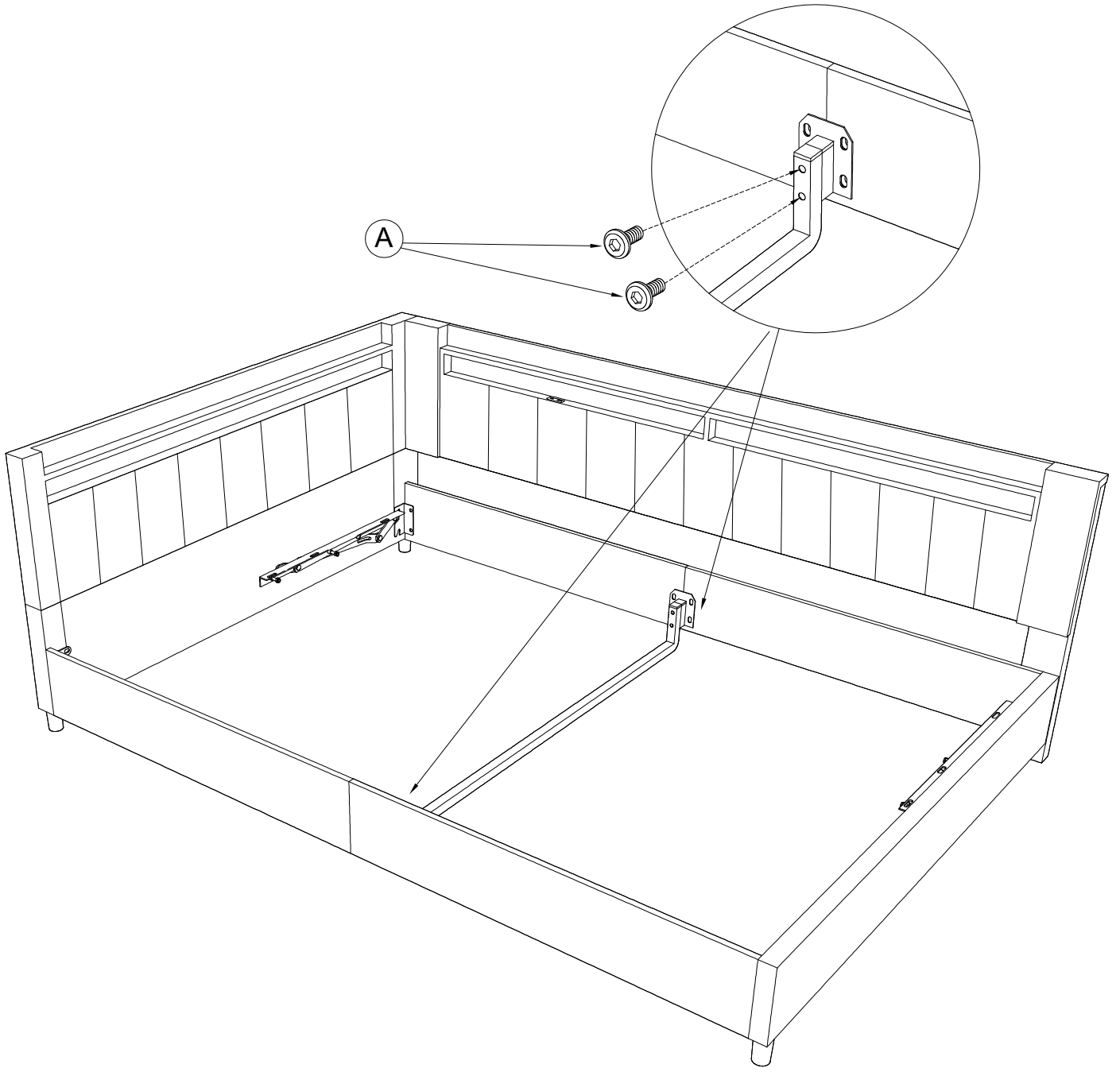



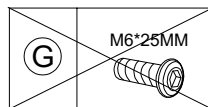
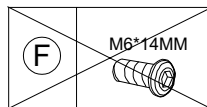
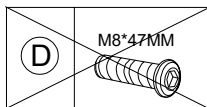
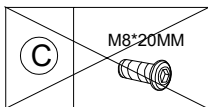
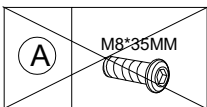
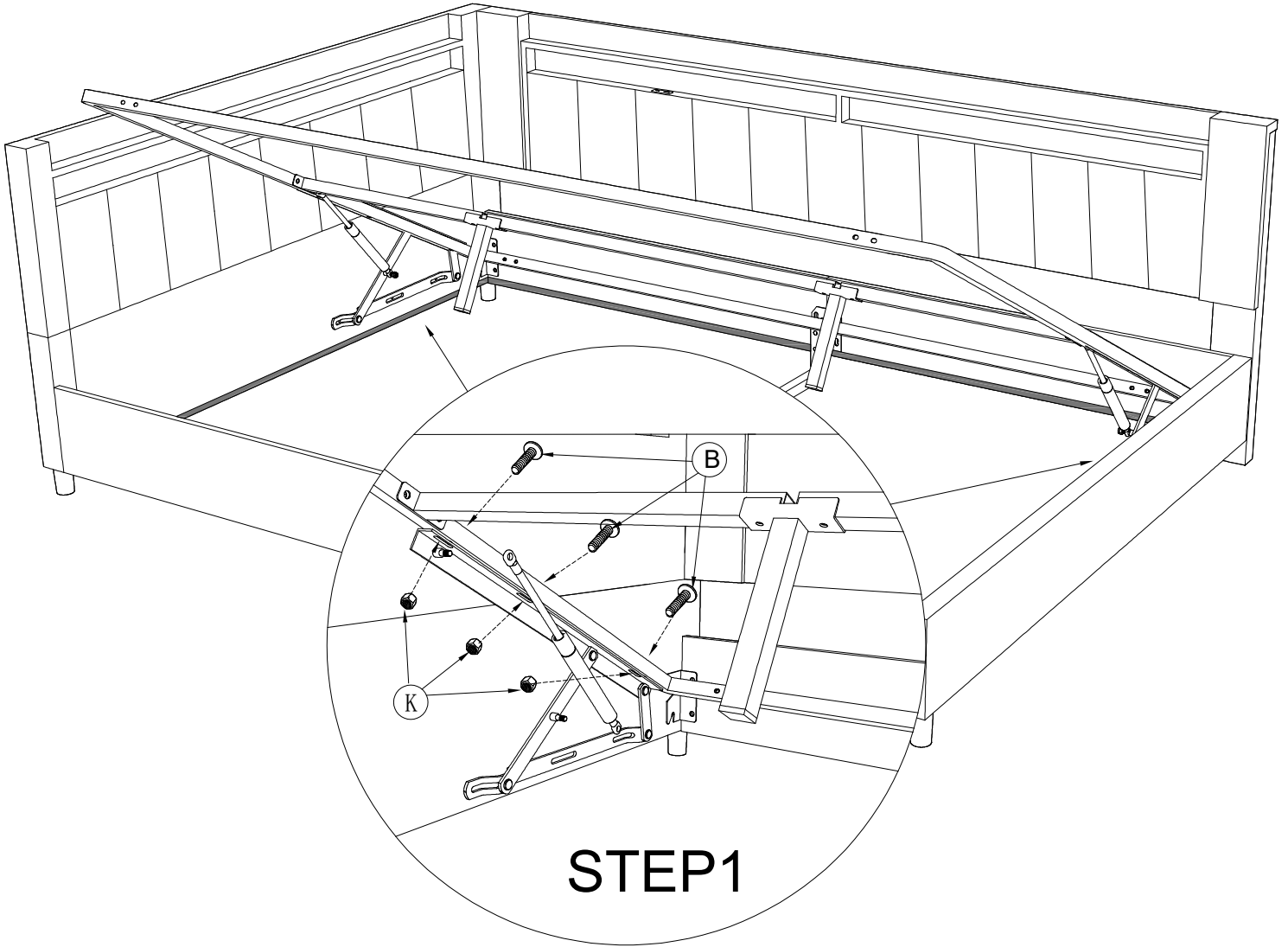

M8*40MM  B*6PCS	 J*1PCS	 K*6PCS
---	---	--

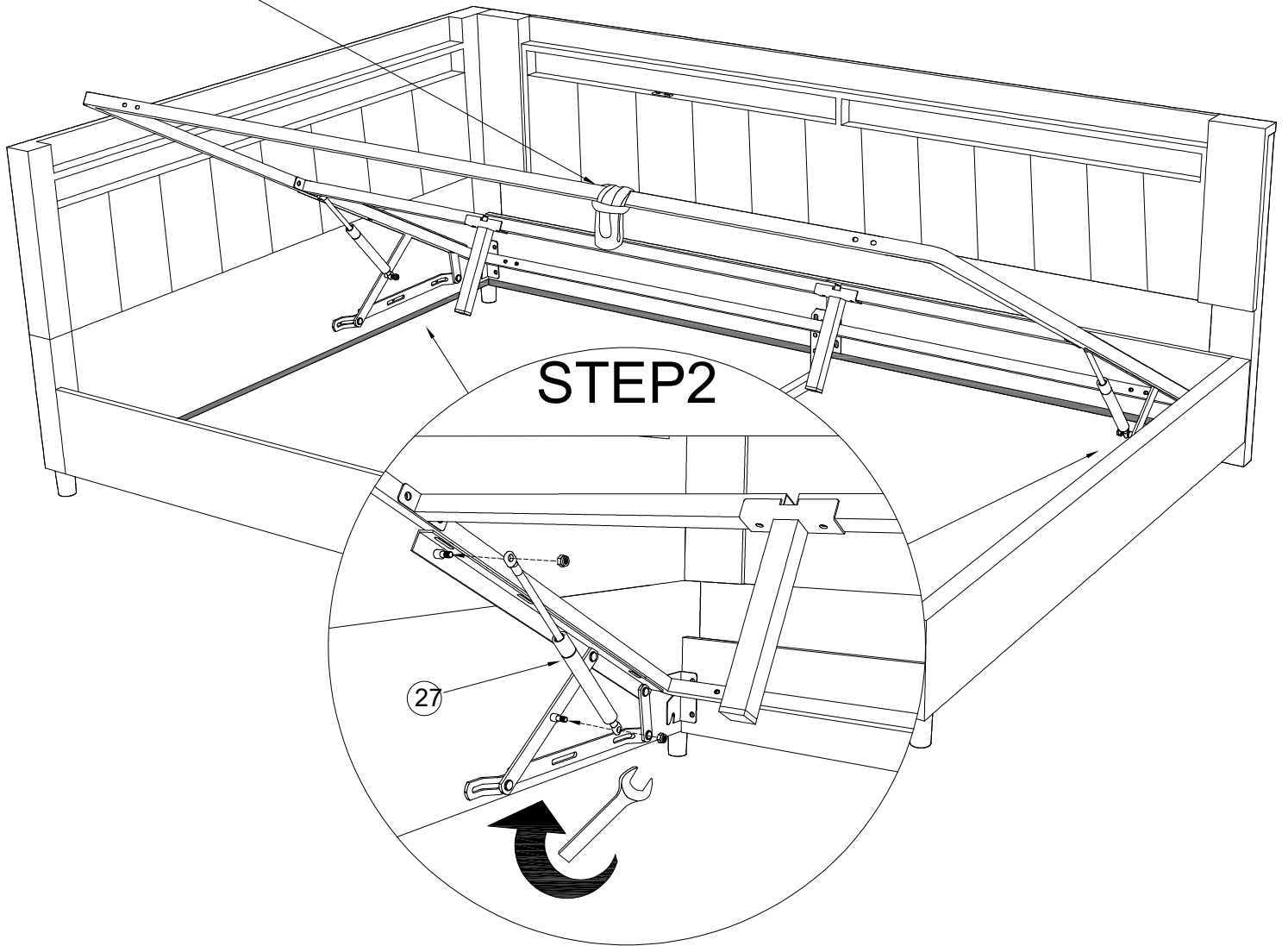
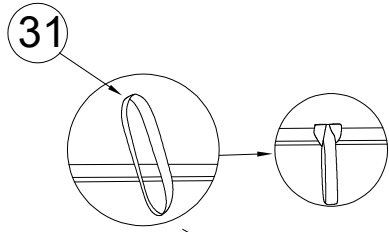



16

M8*47MM  D×2PCS	M6*25MM  G×20PCS
---	--

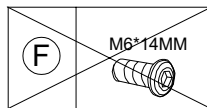
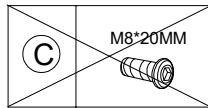
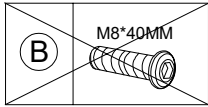
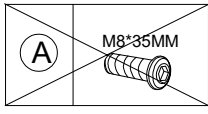
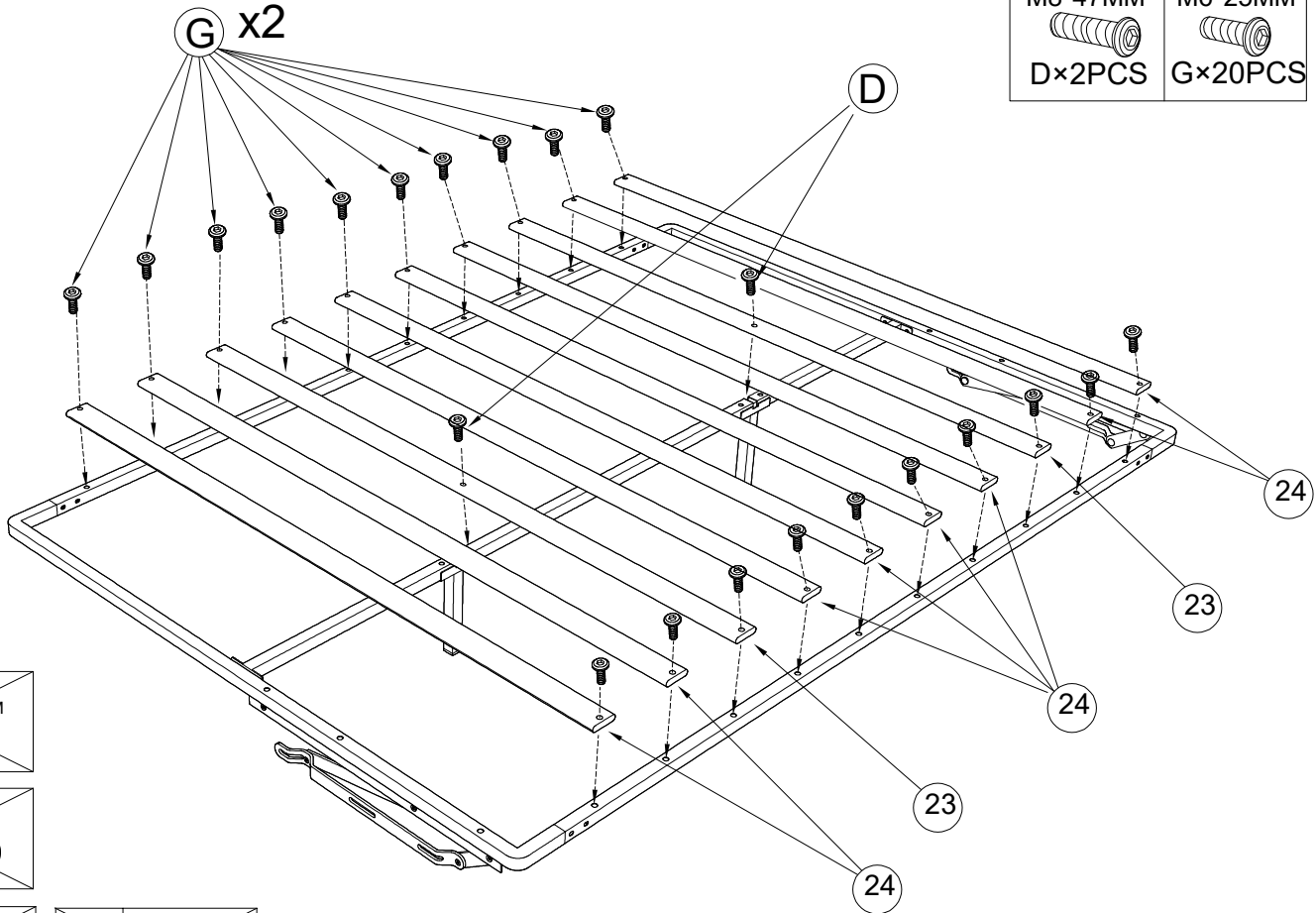

17

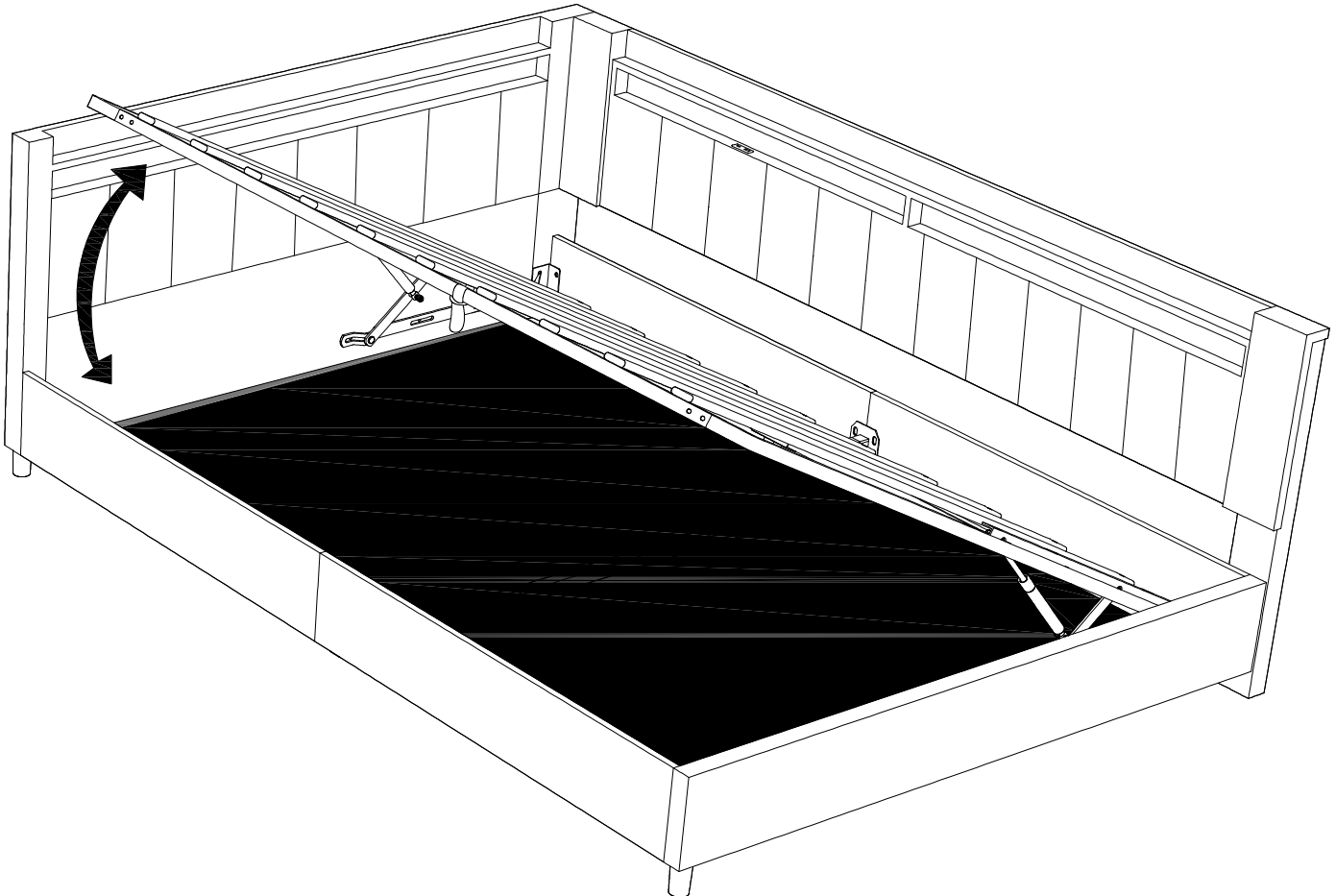

STEP1

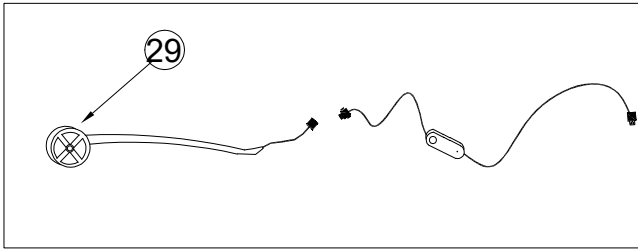

STEP2

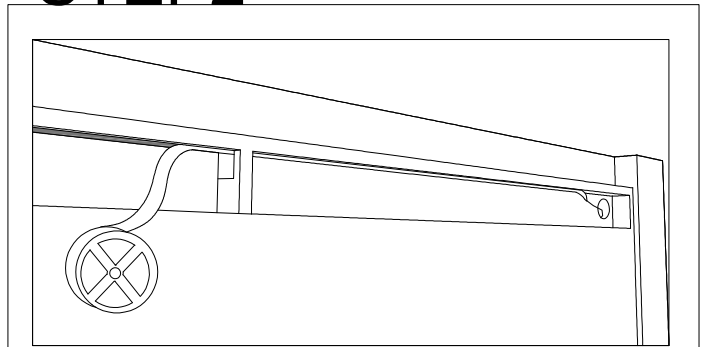

STEP3

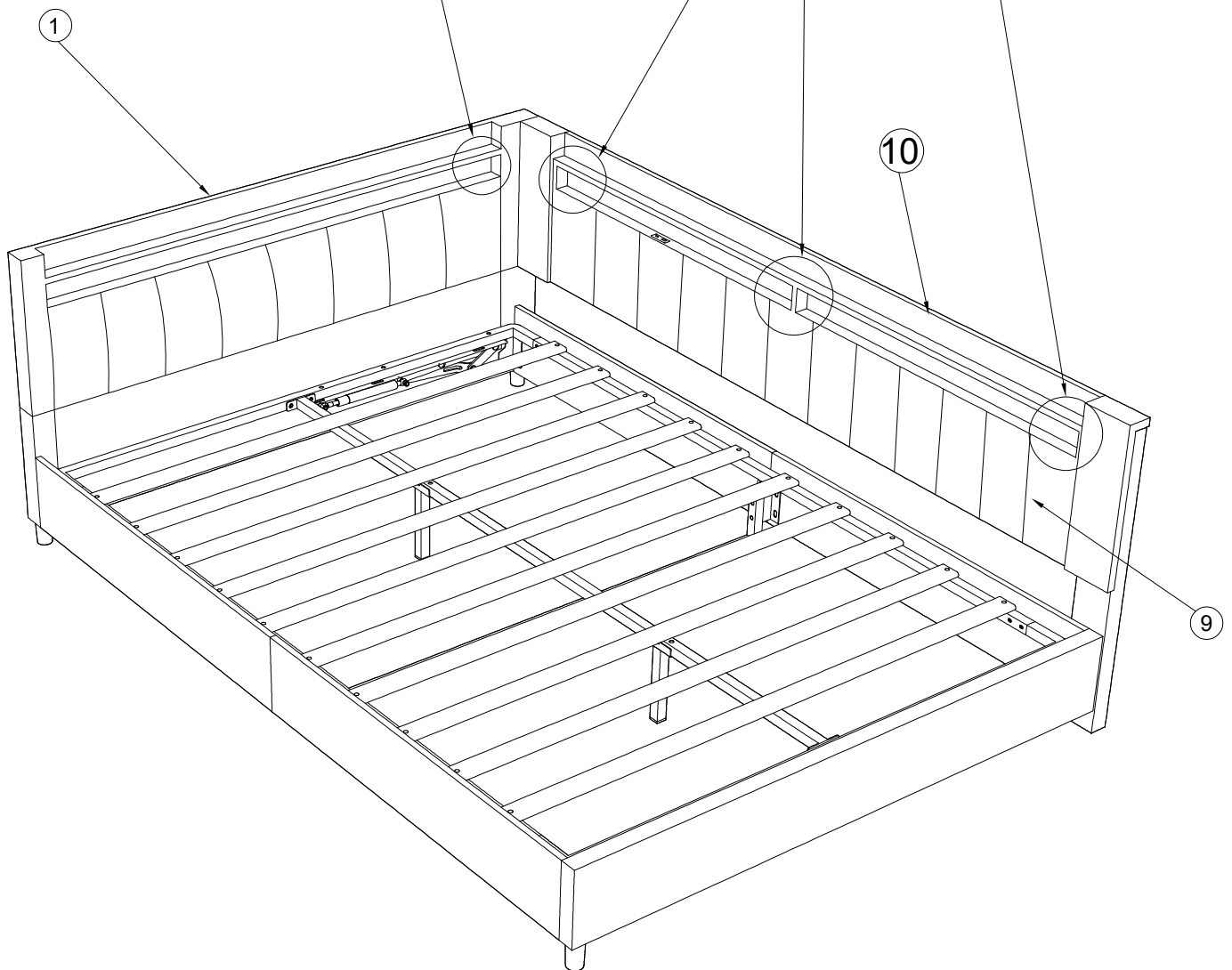
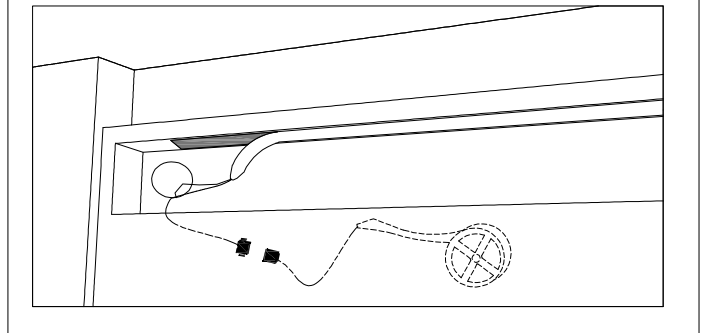
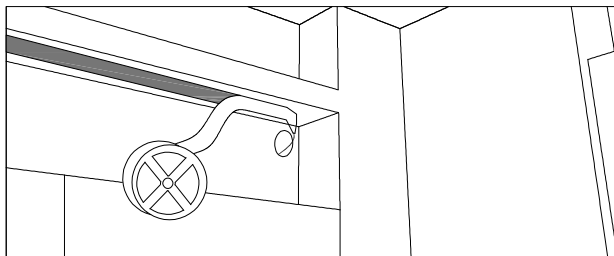

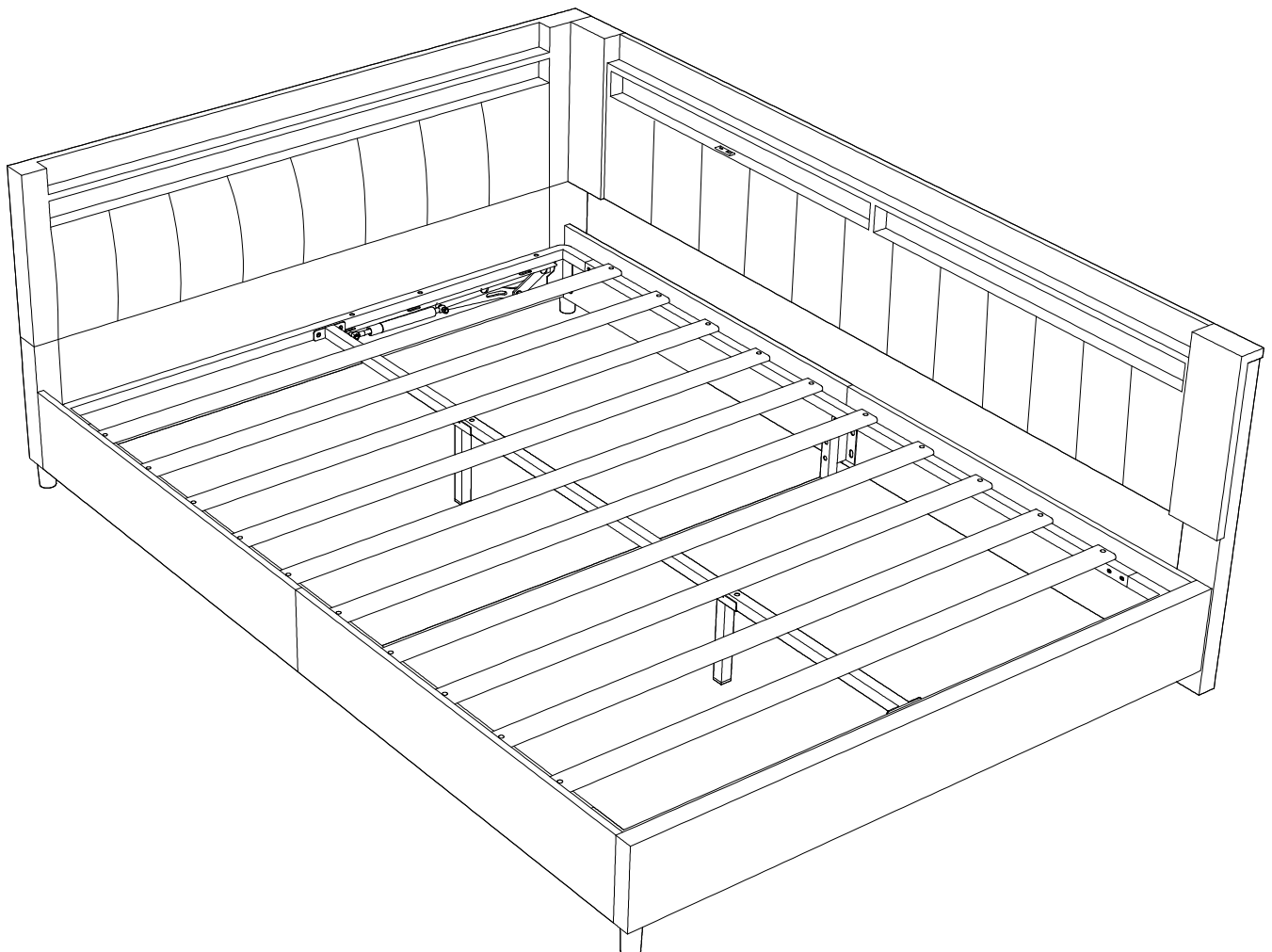
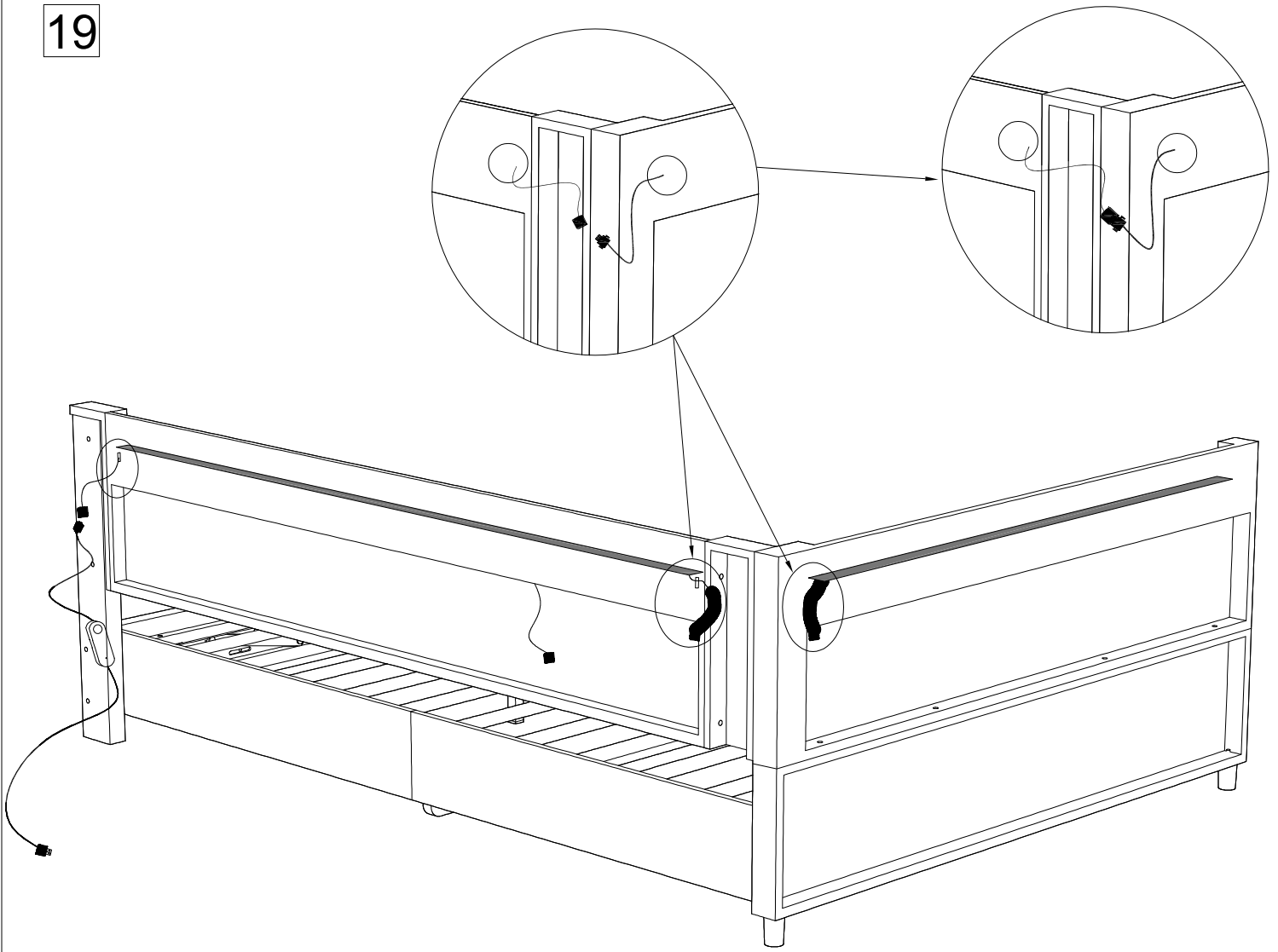

LotusLantern APP Manual

1. Software Overview

1.1 Overview

LotusLantern is a mobile APP to control LED strip by both Apple and Android phones.

The traditional control ways like infrared, 433MHz, 2.4GHz and others old wired ways will be replaced by mobile phone control way with convenient, powerful and scalable features.

Through this mobile APP, you can not only control the color, brightness and color temperature of the LED strips but also set up all kinds of fancy flash mode; Also this APP can change the light of the LED strip according to the rhythm of the music. This APP can set and control several LED strips through Bluetooth and the operation is very simple, easy to learn and easy to use.

1.2 Features

- Adjust color LED strips with 60,000 colors to change color and brightness and adjust monochrome LED strips to change brightness and color temperature
- Play music or turn on a sound playback device, you can let the light change the color and brightness with the rhythm of music, the music rhythm beautiful
- Inside multiple setting mode for color change and control LED strips without mobile
- Long distance control with omni-directional antenna, and many-to-many group control mode
- Once the connection is successful, connect automatically next time

1.3 Performance

LotusLantern APP is easy for use as well as great compatible for all kinds of smart phones; After the actual test of hundreds of mobile phones verification, the compatibility is above 95% of mobile phones in the market. APP is small and convenient, it consumes less system resources, so the requirements of the mobile configuration are low. Control delay is small, the operation feel good, light control is smooth with people's visual sense.

2. Operating Environment

This APP program requires phones of system above Andriod 4.3 and iOS 8.0. Mobile phone configuration is not limited.

3. Instuctions

Note: Android version and iOS version download and use the same method, here in the Android version as an example.

3.1 APP Download

- Scan the QR code

iOS and Android systems can download the "LotusLantern" APP by scanning the QR code. Open the browser or other tools with "Scan QR code" function, scan the "LotusLantern" QR code as below:



3.2 App Operation

- (1) Click on the LotusLantern APP icon, enter the APP page:

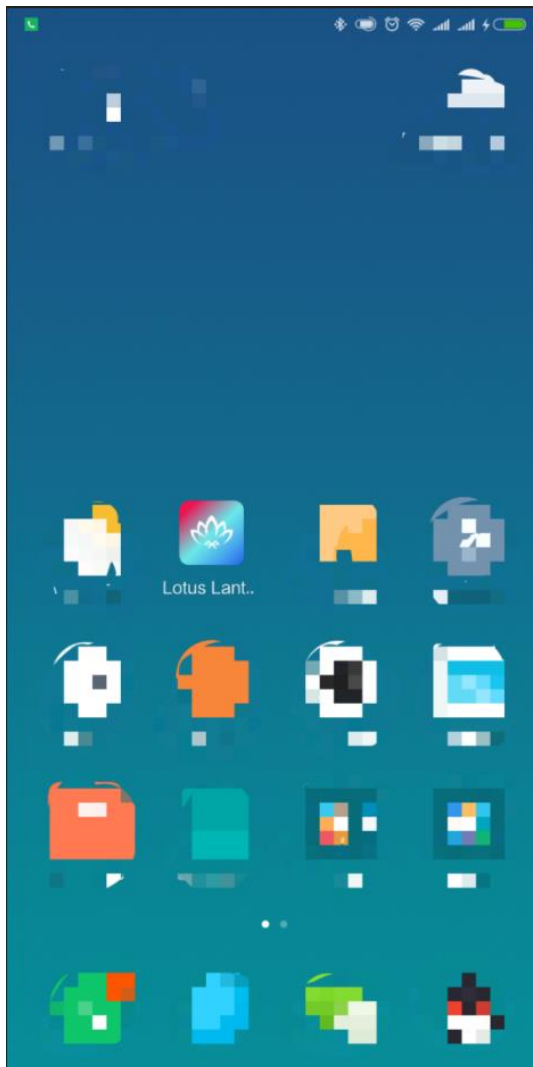

(2) After entering the APP interface, if Bluetooth is not enabled, "an application wants to enable the Bluetooth function of this device." Click [Allow]

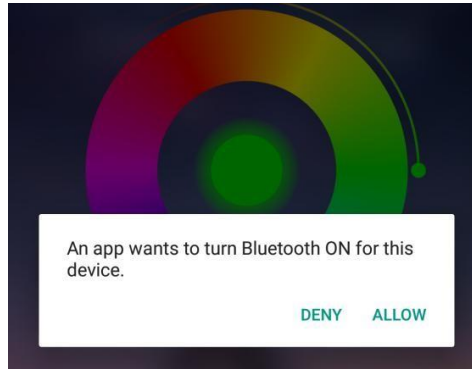

(3) switch to color and brightness interface:

A screenshot of a mobile application interface for color and brightness control. The interface is dark-themed. At the top, there is a navigation bar with a hamburger menu icon, a color wheel icon, and a gear icon. Below the navigation bar, there is a large color wheel for selecting colors. To the right of the color wheel is a toggle switch for the lamp. Below the color wheel, there is a section for RGB values: R 98, G 193, B 111. Below the RGB values is a brightness slider. At the bottom, there are two rows of color preset buttons: "Preset" and "Classic". At the very bottom, there is a navigation bar with icons for "Adjust", "Style", "Music", "Online", and "Mic".

Click to show the lamp list

Switch the color wheel

Click to display setting view

Lamp switch button

Adjust the color

Display the RGB value
Click to manual adjustment view

Click square icon to adjust the color

Click to shift the interface

(4) click to show the lamp list, view lamp list:

Bluetooth auto connect after search for devices

Lamp list

Status of device connection

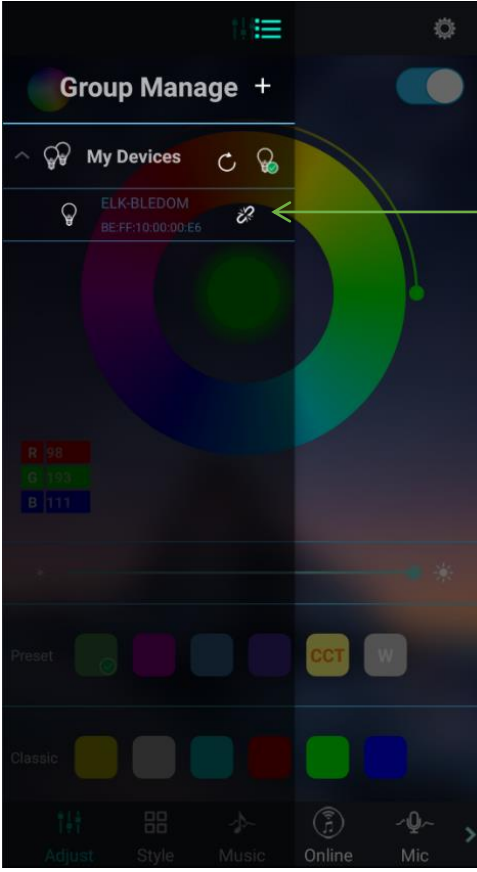
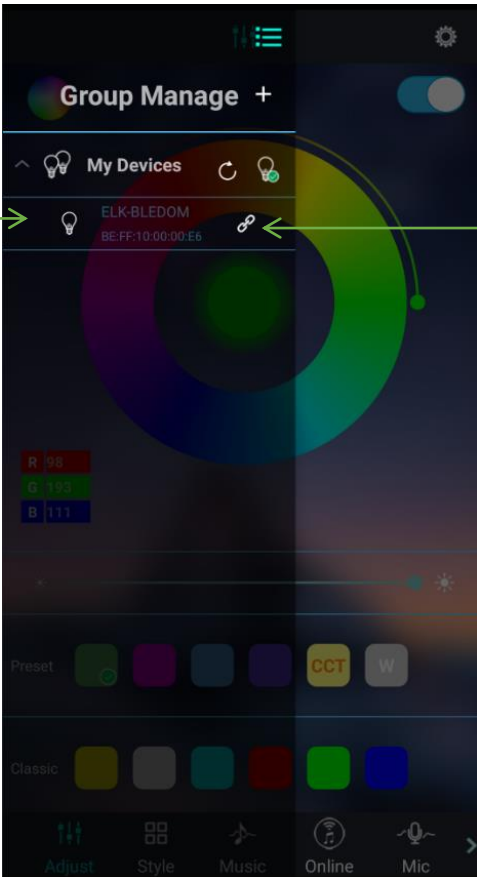

Status of device connection

(5) Click to RGB manual adjustment view:

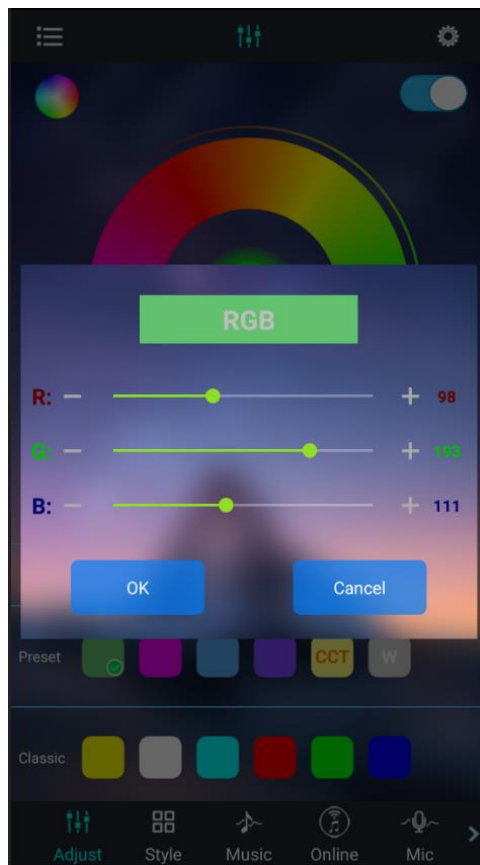

(6) switch to the mode interface:

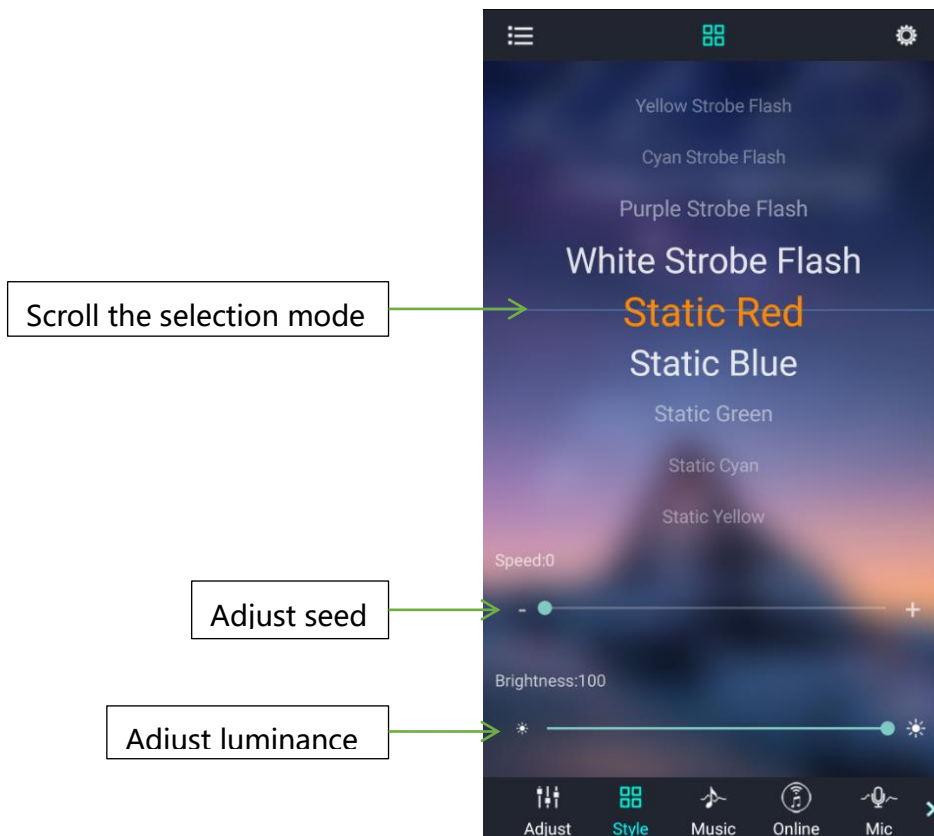

(7) switch to the music rhythm interface:

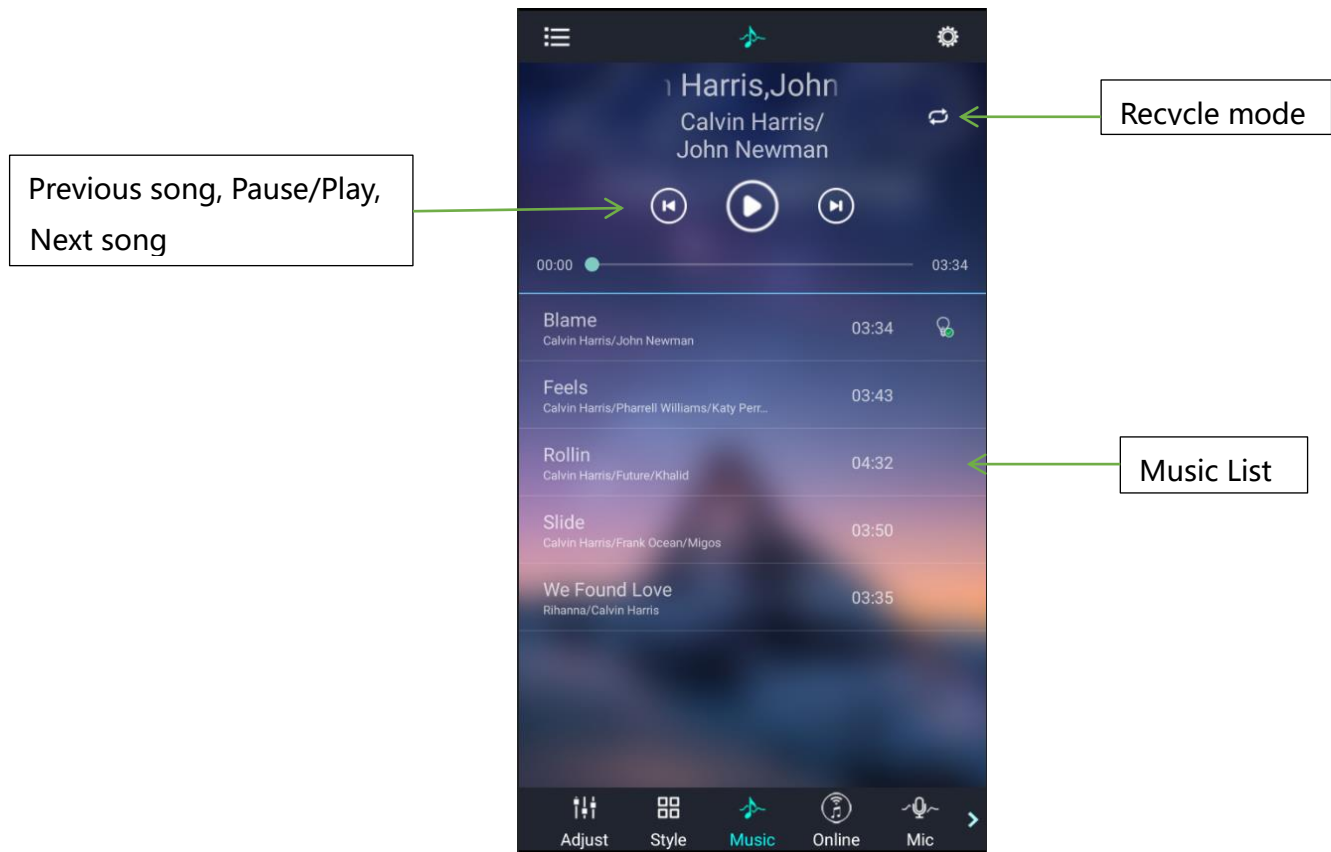

(8) Switch to the online music interface:

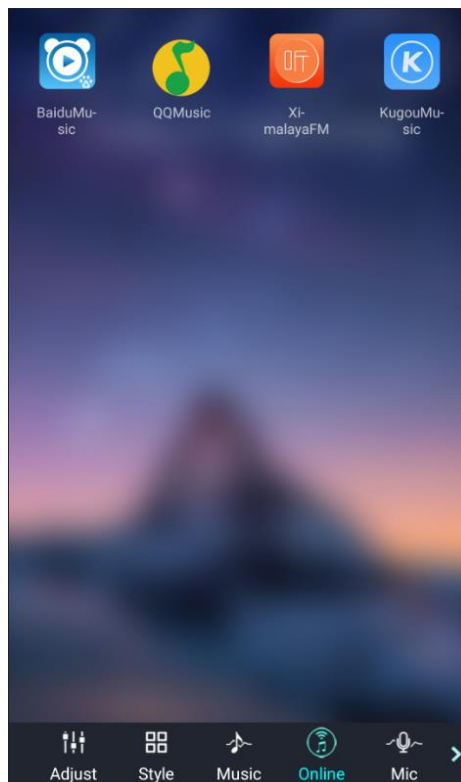

(9) Switch to the microphone rhythm interface:

Music rhythm through cell phone microphone

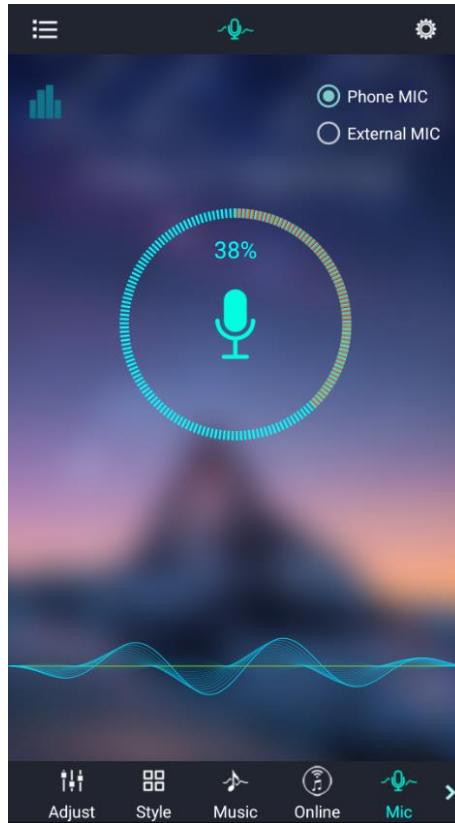

Switch phone microphone and external microphone

Music rhythm through the microphone on the product

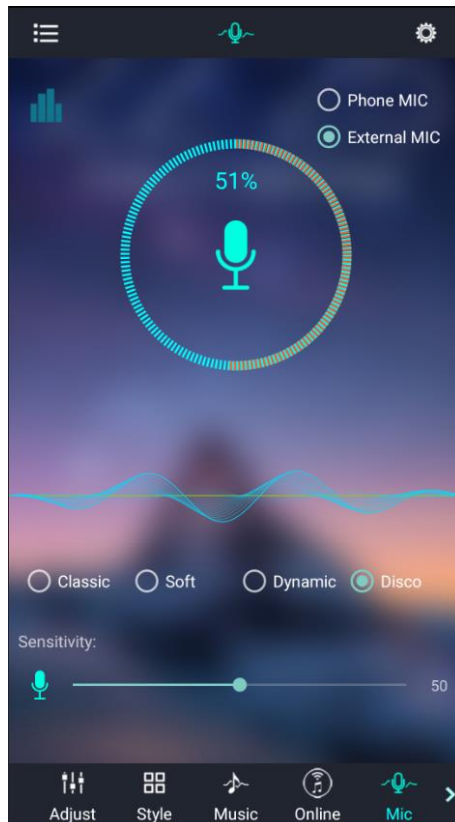

Switch phone microphone and external microphone

4-style rhythm

Change the sensitivity of MIC to match the sound

(10) Switch to the schedule interface:

The screenshot shows the 'Schedule' interface with two main sections: 'Schedule On' and 'Schedule Off'. Each section has a toggle switch, a 'Time' field set to '00:00', and a 'Repeat' row with seven day buttons (MO, TU, WE, TH, FR, SA, SU). The 'Schedule On' toggle is currently off, and the 'Schedule Off' toggle is also off. The bottom navigation bar includes 'Style', 'Music', 'Online', 'Mic', and 'Schedule'.

Annotations on the left side:

- Set the time of Light-On (points to the 'Time' field under 'Schedule On')
- Set the time of Light-Off (points to the 'Time' field under 'Schedule Off')

Annotations on the right side:

- Enable or disable the Light-On function (points to the 'Schedule On' toggle)
- Repeat setting
No selection for once Light-On (points to the 'Repeat' row under 'Schedule On')
- Enable or disable the Light-Off function (points to the 'Schedule Off' toggle)
- Repeat setting
No selection for once Light-Off (points to the 'Repeat' row under 'Schedule Off')

(11) Switch to the modify pin sequence interface:

The screenshot shows the 'Modify Pin Sequence' interface. At the top, there is a 'Modify Pin Sequence' title and a back arrow. Below the title is a 3D rendering of a pin header with a white connector. Below the pin header is a grid of 12 buttons arranged in 3 rows and 4 columns. The first row has buttons labeled 'V+', 'R', 'G', and 'W'. The second and third rows have buttons labeled 'G', 'B', and 'W'. A red box highlights the first column of buttons (R, G, B). A callout box points to the 'R' button.

Annotations on the left side:

- Click to save the new assignment (points to the 'R' button)
- Change the real color of this line (points to the 'R' button)

Shenzhen ZKT Technology Co., Ltd.

1/F, No. 101, Building B, No. 6, Tangwei Community Industrial Avenue,
Fuhai Street, Bao'an District, Shenzhen, China



Certificate of Compliance

Certificate Number: ZKT-25070215182C

Certificate's Holder : Dongguan Yihong Hardware Electronics Co., Ltd
Room 1106, No.2, Shangheng Road, Chang' an Town,
Dongguan

Manufacturer : Dongguan Yihong Hardware Electronics Co., Ltd
Room 1106, No.2, Shangheng Road, Chang' an Town,
Dongguan

Trade Mark : N/A

Product : LED controller

Model(s) : YH-6183
YH-252, YH-284, YH-290, YH-287, YH-358, YH-360, YH-6180,
YH-6184

Requirement	Standard	Report No.
Art.3.1(a) Safety	EN IEC 62368-1:2024+A11:2024	ZKT-25070215183S
Art.3.1(a) Health	EN IEC 62311:2020 EN 50665:2017	ZKT-25070215182E-1
Art.3.1(b) EMC	ETSI EN 301 489-1 V2.2.3 (2019-11) ETSI EN 301 489-17 V3.3.0 (2024-07)	ZKT-25070215182E-2
Art.3.2 Radio	ETSI EN 300 328 V2.2.2 (2019-07)	ZKT-25070215182E-3

This Attestation of Compliance is issued on a voluntary basis for electrical equipment below the voltage limits of Radio Equipment Directive (RED) 2014/53/EU. The essential requirements are fulfilled accordingly based on the technical specifications applicable at the time of issuance.

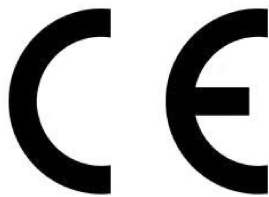

This Certificate of Conformity is based on single evaluation of the submitted sample(s) of the above mentioned product. It does not imply an assessment of the whole product and relevant Directives to be observed.

Verification of Compliance

Verification No.: MK25070091P01-C01

Name and address of Applicant: **Shenzhen CWG Technology Co., Ltd**
3/F, Building A, Yongshenghui Industrial Park, Chuangye Road, Shiyan Street, Bao'an District, Shenzhen

Name and address of Manufacturer: **Shenzhen CWG Technology Co., Ltd**
3/F, Building A, Yongshenghui Industrial Park, Chuangye Road, Shiyan Street, Bao'an District, Shenzhen

Product name: **LED Strip**
CWG-5050RGB-60D-5V, CWG-5050RGB-30D-12V, CWG-5050RGB-18D-12V, CWG-5050RGB-60D-24V, CWG-5050RGB-60D-12V, CWG-5050RGB-30D-5V, CWG-5050RGB-18D-5V, CWG-5050-60D-12V, CWG-5050-30D-12V, CWG-5050-60D-24V, CWG-HC5050RGB-60D-12V, CWG-HC5050RGB-30D-12V, CWG-HC5050RGB-60D-24V, CWG-HC5050-60D-12V, CWG-HC5050-30D-12V, CWG-HC5050-60D-24V, CWG-HC5050RGB-30D-5V, CWG-HC5050RGB-60D-5V, CWG-HC5050RGB-144D-5V, CWG-2835-60D-12V, CWG-2835-120D-12V, CWG-2835-60D-24V, CWG-2835-120D-24V, CWG-2835-60D-5V, CWG-2835-120D-5V

Product model(s):

Product trademark: 创唯光

This verification confirms that the product meets the requirements of the following standard. The conformity was demonstrated based on following standard(s) listed by European Commission as harmonized with Directive RoHS 2.0 Directive (EU) 2015/863 and (EU)2017/2102 amending Annex II to Directive 2011/65/EU

- | | |
|----------------------------|--------------------|
| IEC 62321-1:2013 | IEC 62321-3-1:2013 |
| IEC 62321-4:2013/AMD1:2017 | IEC 62321-5:2013 |
| IEC 62321-6:2015 | IEC 62321-7-1:2015 |
| IEC 62321-7-2:2017 | IEC 62321-8:2017 |
| IEC 62321-2:2021 | |

The verification has been carried out in accordance with individual rules and conditions agreed with the applicant. Evaluation has been carried out in accordance with:

Test report(s) No.: MK25070091P01-C01
 Test conducted by: TMC Testing Services (Shenzhen) Co., Ltd.
 Verification issue date: July 17, 2025

Notes:

This verification refers to the above mentioned product and its conformity in regards of above mentioned standard(s) was proven on test sample.
This verification does not imply meeting all essential requirements, assessment of the series-production or any other restricted Notified Bodies conformity assessment procedure appropriate for the product.
This verification holder shall use this verification in connection to verification of conformity and technical data relevant for the product the verification was issued.

TMC Testing Services (Shenzhen) Co., Ltd.

t:86-755-86642861 cert@tmc-lab.com www.tmc-lab.com
 1st Floor, Block A1, Zone A, Xinshidai Gongrong Industrial Park, No. 2, Shihuan Road, Shiyan Street, Baoan District, Shenzhen, China





Product Service

Attestation of Conformity

No. E8A 128892 0006 Rev. 00

Holder of Attestation: **GUANG TAI ENTERPRISE CO., LTD.**Rm 402, Bldg 4. No.2 Dapianmei Rd.
Dapianmei Village, Dalingshan
523000 Dongguan, Guangdong
PEOPLE'S REPUBLIC OF CHINA**Name of Object:** **Power supply
(Furniture Power Distribution Unit)****Model(s):** **JN00-00-02K, JN00-00-03K, JN00-00-04K, JN02-00-21,
JN02-00-22, JN02-00-23, JN02-00-23K, JN02-00-24K,
JN02-00-24, JN02-00-22M, JN02-00-23M, JN02-00-23KM****Description of Object:** Ratings:
Input: 220-250VAC, 50Hz, Max 16A, Max 3680W
USB A1/USB A2 Output: 5.0VDC, 2.1A, 10.5W Max
Total USB output: 5.0VDC, 2.1A, 10.5W Max
Protection Class: I**Tested according to:** EN 55032:2015/A1:2020
EN 55035:2017/A11:2020
EN IEC 61000-3-2:2019/A1:2021
EN 61000-3-3:2013/A2:2021

This Attestation of Conformity is issued on a voluntary basis according to the Directive 2014/30/EU relating to electromagnetic compatibility. It confirms that the listed apparatus complies with the principal protection requirements of the directive and is based on the technical specifications applicable at the time of issuance. It refers only to the particular sample submitted for conformity assessment. For details see: www.tuvsud.com/ps-cert

Test report no.: 657602423101**Date,** 2025-01-10

(Laurent Yuan)

Page 1 of 1

This Attestation does not replace the regulatory EU Declaration of Conformity (DoC) and does not allow for CE marking. After preparation of the necessary documentation and establishing compliance to requirements of all applicable directives, the manufacturer may sign a DoC and apply the CE marking. The DoC is issued under the sole responsibility of the manufacturer.



SLG-CPC Testlaboratory Dongguan Co., Ltd.

VERIFICATION OF CONFORMITY

No.: 24050295C-C

This verification is issued for

GUANG TAI ENTERPRISE CO LTD

Rm 402, Bldg 4, No.2 Dapianmei Rd., Dapianmei Village, Dalingshan, DONGGUAN, Guangdong, China

The product with designation of type

Furniture Power Distribution Unit

Trade Mark: N/A

Model/s: JN00-00-02K; JN00-00-02KM; JN00-00-03K; JN00-00-03KM; JN00-00-04; JN00-00-04K; JN00-00-04KM; JN02-00-21; JN02-00-22; JN02-00-22M; JN02-00-23; JN02-00-23K; JN02-00-23M; JN02-00-23KM; JN02-00-24K; JN02-00-24; JN02-00-24M; JN02-00-24KM

This is to declare that the technical file of the products complies the essential requirements of below European Directives:

Low Voltage Directive 2014/35/EU;

Reference standards:

**IEC 60884-2-7:2011+ AMD1:2013
IEC 60884-1:2002 + AMD1:2006
IEC 62368-1:2018 (EN IEC 62368-1:2020 + A11:2020)**

This verification is based on the following file

90340-24-70-24-PP001

And is valid only if the product is manufactured in accordance with the corresponding tested sample.

This verification is the result of tests carried out on one sample and does not represent the serial production of this product.

The CE mark as show can be used, under the responsibility of the manufacturer, after completion of an EC Declaration of Conformity and compliance with all relevant EC Directives.

This verification of conformity loses its validity in the following cases:

- if the reference standards and/or EC Directives are modified;
- if any modifications are made to the model/s without our approval.



2024-05-11

(Date)

Owen Zhan
Owen Zhan
Technical Director

Certificate of Compliance

RoHS Directive 2011/65/EU appendix II Revised instructions (EU) 2015/863 of the European parliament and of the council on the restriction of the use of certain hazardous substances in electrical and electronic equipment

Issue Date: Nov.27, 2025

Company Name	: GUANG TAI ENTERPRISE CO.,LTD
Address	: Rm402,Bldg 4,No.2 Dapianmei Rd.Dapianmei Village,Dalingshang DONGGUAN GUANGDONG
Manufacturer	: GUANG TAI ENTERPRISE CO.,LTD
Address	: Rm402,Bldg 4,No.2 Dapianmei Rd.Dapianmei Village,Dalingshang DONGGUAN GUANGDONG
Sample Name	: Furniture Power Distribution Unit
Sample Model	: JN02-00-21;JN02-00-111;JN02-00-112;JN02-00-212; JN02-00-22;JN00-00-02K;JN02-00-113K;JN02-00-113; JN02-00-213;JN02-00-23;JN00-00-03K;JN00-00-03; JN00-00-04K;JN00-00-04; JNO2-00-23

This certificate of compliance is based on a test procedure or an evaluation of the above-mentioned product. This is to certify that the above-mentioned product is in compliance with the RoHS Directive 2011/65/EU appendix II Revised instructions (EU) 2015/863 of the European parliament.

It is only valid in connection with the test report (Report No.: COBO25110736)

RoHS

Signed for and on Behalf of COBO



Sam Xie / Technical Manager

GUANGDONG TICOBO TESTING CO.,LTD.

EA601,Yishili Building No.9,Zongbu 2nd Road,Songshan Lake Sci.&Tech. Park,Dongguan,Guangdong,China

Tel:86-769-26622263 Fax:86-769-26622012

