

N635P466403

N635P466404

N635P466405

Product manual

Gebrauchsanweisung

Manuel du produit

Manual del producto

Manuale del prodotto

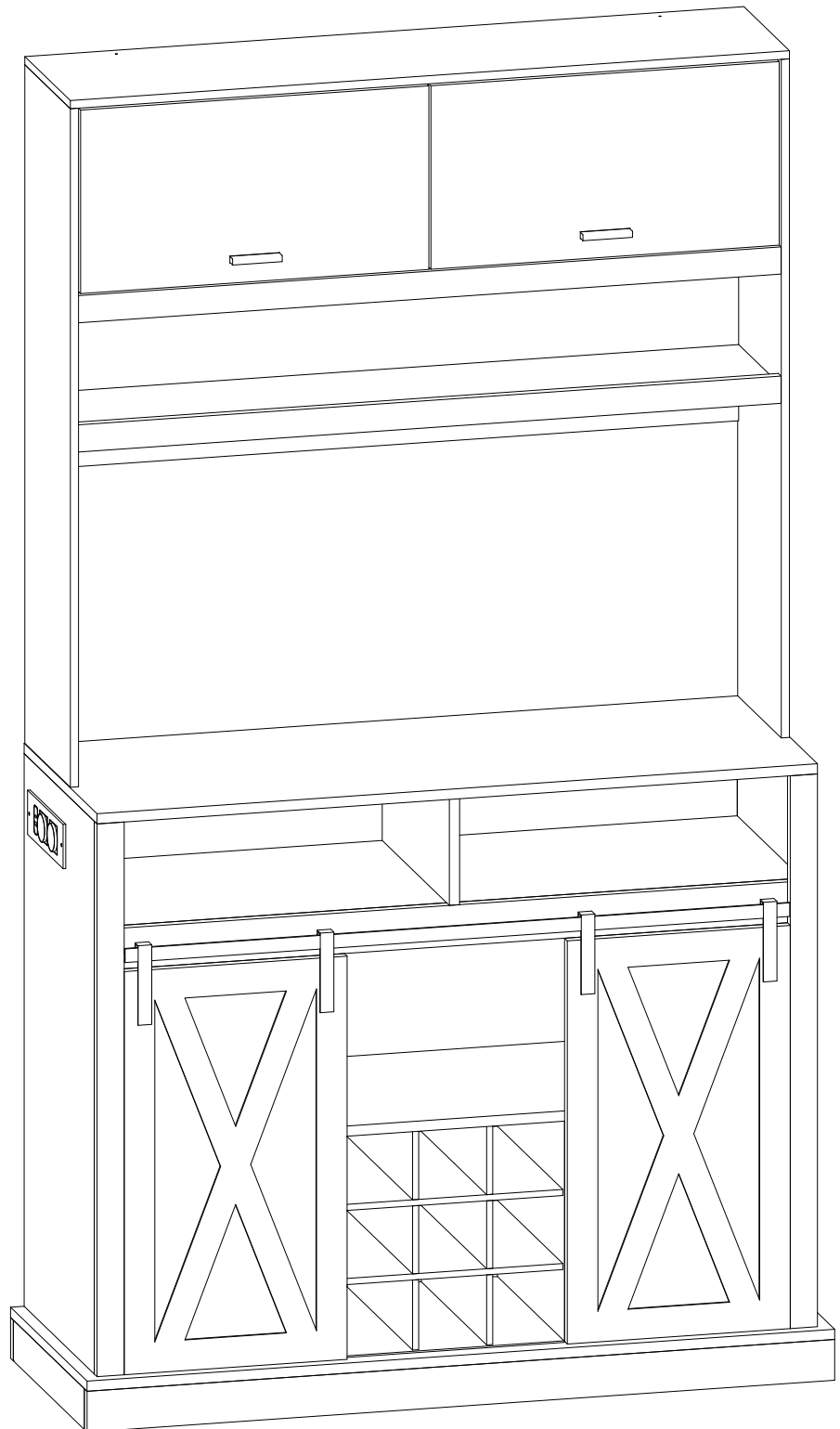

EN:Our product will be delivered to you in 3 packages.The delivery times of these 3 packages may differ, please be patient and thank you for your understanding
FR:Notre produit vous sera livré en 3 colis.Les délais de livraison de ces 3 colis peuvent différer,soyez patient et merci de votre compréhension.

DE:Unser Produkt wird Ihnen in 3 Paketen geliefert.Die Lieferzeiten dieser 3 Pakete können abweichen, bitte haben Sie etwas Geduld und vielen Dank für Ihr Verständnis

IT:I nostri prodotti vengono trasportati in 3 pacchetti. I tempi di consegna dei 3 pacchetti sono diversi:abbiate pazienza e vi ringrazio per la vostra comprensione.

ES:Nuestro producto se entrega en 3 paquetes. El tiempo de entrega de estos 3 paquetes es diferente. Por favor, sea paciente. Gracias por su comprensión.

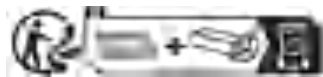



[DE]

Warnung: Lesen Sie diese Anleitung vor dem Zusammenbau bitte vollständig durch. Überprüfen Sie, ob Sie alle auf den Seiten aufgeführten Komponenten und Werkzeuge haben. Bewahren Sie die Anleitung zum späteren Nachschlagen auf. Teile des Zusammenbaus lassen sich mit 2 Personen leichter durchführen. Suchen Sie bei Bedarf professionelle Hilfe.

Warnung: Legen Sie alle Teile auf eine ebene Fläche. Legen Sie eine weiche Decke oder Ähnliches darunter, um sie vor Kratzern oder Flecken zu schützen. Vermeiden Sie es, Komponenten über den Boden zu ziehen oder zu schieben.

Warnung: Überprüfen Sie regelmäßig alle Beschläge und Befestigungen, um sicherzustellen, dass sie sicher sind und um Unfälle zu vermeiden. Wenn Teile fehlen, kaputt, beschädigt oder abgenutzt sind, verwenden Sie das Produkt nicht weiter, bis es mit vom Hersteller autorisierten Teilen repariert wurde.

Warnung: Lassen Sie Kinder nicht auf die Möbel klettern, da dies zum Umkippen und zu schweren Verletzungen führen kann. Bauen Sie die Möbel außerhalb der Reichweite von Kindern zusammen.

Warnung: Stellen Sie die Möbel nicht in die Nähe von Feuerquellen oder heißen Gegenständen, um Brandgefahr zu vermeiden.

Warnung: Reinigen Sie die Möbel mit einem feuchten Tuch oder Alkohol. Verwenden Sie keine Reinigungsmittel mit ätzenden Chemikalien.

Warnung: Dieses Produkt ist mit einer Kippschutzvorrichtung ausgestattet. Bitte installieren Sie diese Vorrichtung unbedingt, um unnötige Verletzungen durch Umkippen zu vermeiden.

[EN]

Warning: Please read these instructions fully before starting assembly. Check you have all the components and tools listed on pages. Keep the instructions for later reference. Parts of the assembly will be easier with 2 people. Seek professional assistance if necessary.

Warning: Please place all parts on a flat surface. Place a soft blanket or similar underneath to protect against scratches or stains. Avoid dragging or sliding components across the floor.

Warning: Regularly check all fittings and fastenings to ensure they are secure and to prevent accidents. If any parts are missing, broken, damaged, or worn, discontinue use of the product until repairs have been made using factory authorized parts.

Warning: Do not allow children to climb on the furniture as this may result in tipping and serious personal injury. Assemble the furniture away from the reach of children.

Warning: Do not place furniture close to fire sources or high-temperature objects to avoid the risk of fire. Do not place furniture in damp environments to prevent material damage.

Warning: Clean furniture with a damp cloth or alcohol, avoid using cleaning agents containing corrosive chemicals.

Warning: This product is equipped with an anti-tilt device. Please be sure to install this device to prevent unnecessary injuries caused by tipping.

[FR]

Avertissement : Veuillez lire attentivement ces instructions avant de commencer l'assemblage. Vérifiez que vous disposez de tous les composants et outils répertoriés sur les pages. Conservez les instructions pour référence ultérieure. Certaines parties de l'assemblage seront plus faciles à 2 personnes. Demandez l'aide d'un professionnel si nécessaire.

Avertissement : Veuillez placer toutes les pièces sur une surface plane. Placez une couverture douce ou similaire en dessous pour les protéger des rayures ou des taches. Évitez de faire glisser les composants sur le sol.

Avertissement : Vérifiez régulièrement tous les raccords et fixations pour vous assurer qu'ils sont bien fixés et pour éviter les accidents. Si des pièces manquent, sont cassées, endommagées ou usées, cessez d'utiliser le produit jusqu'à ce que des réparations aient été effectuées à l'aide de pièces autorisées par l'usine.

Avertissement : Ne laissez pas les enfants grimper sur les meubles car cela pourrait entraîner un basculement et des blessures graves. Assemblez les meubles hors de portée des enfants.

Avertissement : Ne placez pas les meubles à proximité de sources de feu ou d'objets à haute température pour éviter tout risque d'incendie.

Avertissement : Nettoyez les meubles avec un chiffon humide ou de l'alcool, évitez d'utiliser des produits de nettoyage contenant des produits chimiques corrosifs.

Avertissement : Ce produit est équipé d'un dispositif anti-basculement. Assurez-vous d'installer ce dispositif pour éviter les blessures inutiles causées par un basculement.

[IT]

Attenzione: leggere attentamente queste istruzioni prima di iniziare il montaggio. Verificare di avere tutti i componenti e gli strumenti elencati nelle pagine. Conservare le istruzioni per riferimento futuro. Alcune parti del montaggio saranno più facili con 2 persone. Se necessario, chiedere assistenza professionale.

Attenzione: posizionare tutte le parti su una superficie piana. Posizionare una coperta morbida o simile sotto per proteggere da graffi o macchie. Evitare di trascinare o far scivolare i componenti sul pavimento.

Attenzione: controllare regolarmente tutti i raccordi e i dispositivi di fissaggio per assicurarsi che siano sicuri e per prevenire incidenti. Se alcune parti sono mancanti, rotte, danneggiate o usurate, interrompere l'uso del prodotto fino a quando non siano state eseguite le riparazioni utilizzando parti autorizzate dalla fabbrica.

Attenzione: non consentire ai bambini di arrampicarsi sui mobili poiché ciò potrebbe causare ribaltamenti e gravi lesioni personali. Montare i mobili lontano dalla portata dei bambini.

Attenzione: non posizionare i mobili vicino a fonti di fuoco o oggetti ad alta temperatura per evitare il rischio di incendio

Attenzione: pulire i mobili con un panno umido o alcol, evitare di utilizzare detergenti contenenti sostanze chimiche corrosive.

Attenzione: questo prodotto è dotato di un dispositivo antiribaltamento. Assicurarsi di installare questo dispositivo per prevenire lesioni inutili causate dal ribaltamento.

[ES]

Advertencia: Lea estas instrucciones completamente antes de comenzar el montaje. Compruebe que tiene todos los componentes y herramientas que se enumeran en las páginas. Conserve las instrucciones para consultarlas más adelante. El montaje de algunas partes será más sencillo con 2 personas. Busque ayuda profesional si es necesario.

Advertencia: Coloque todas las piezas sobre una superficie plana. Coloque una manta suave o algo similar debajo para protegerlas de rayones o manchas. Evite arrastrar o deslizar los componentes por el piso.

Advertencia: Verifique regularmente todos los accesorios y fijaciones para asegurarse de que estén seguros y evitar accidentes. Si falta alguna pieza, está rota, dañada o desgastada, deje de usar el producto hasta que se hayan realizado las reparaciones con piezas autorizadas de fábrica.

Advertencia: No permita que los niños se suban a los muebles, ya que esto puede provocar que se vuelquen y lesiones personales graves. Monte los muebles fuera del alcance de los niños.

Advertencia: No coloque los muebles cerca de fuentes de fuego u objetos de alta temperatura para evitar el riesgo de incendio.

Advertencia: Limpie los muebles con un paño húmedo o alcohol, evite usar agentes de limpieza que contengan químicos corrosivos.

Advertencia: Este producto está equipado con un dispositivo antivuelco. Asegúrese de instalar este dispositivo para evitar lesiones innecesarias causadas por vuelcos.

Importeur	Decobus Handel GmbH
Adresse	Innungsstraße 9, 21244 Buchholz, Deutschland
Email/URL	https://www.decobusgroup.de
Hersteller	Xiamen Worldwide Industry Co., Ltd.
Adresse	Unit 803, Hongyihua Palace, 388 Qishan Rd, Huli High-tech Park, Xiamen, China
Email/URL	info@wdwide.com
Partienummer	N635P466403/N635P466404/N635P466405
Hergestellt in	China
	Decobus Handel GmbH Innungsstraße 9, 21244 Buchholz, Deutschland https://www.decobusgroup.de

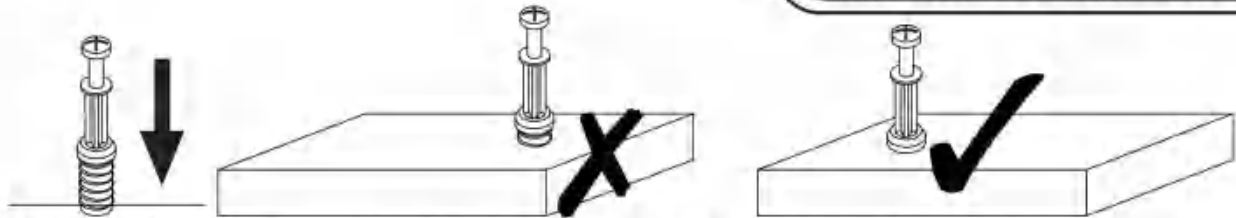

EN_QUICKFIT: Tighten quickfit until shoulder is flush with panel. Do not overtighten or undertighten.

FR_RACCORD RAPIDE: Faites serrer le raccord rapide jusqu'à ce que l'épaulement soit parfaitement encastré dans le panneau. Il ne faut ni trop serrer ni insuffisamment serrer.

ES_QUICKFIT: Apriete quickfit hasta que el hombro se descargue con el panel. NO lo sobreapriete ni lo apriete poco.

DE_QUICKFIT: Ziehen Sie den Quickfit fest, bis die Schulter mit der Platte bündig ist. Bitte nicht zu fest oder zu schwach anziehen.

IT_MONTAGGIO RAPIDO: Stringere il montaggio rapido fino a quando la spalla è a filo con il pannello, non stringere troppo o troppo poco.

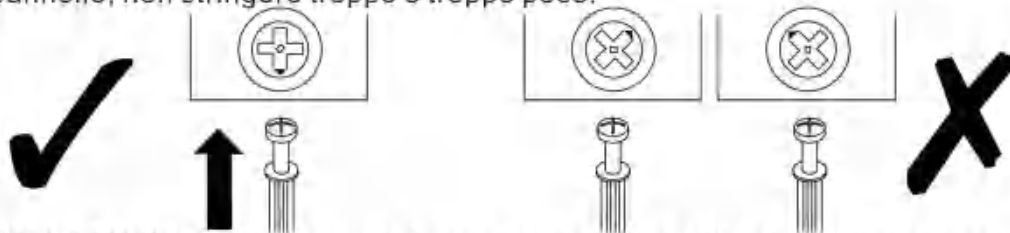

EN_CAM LOCK: When fitting cam lock, ensure starting position is correct before you insert connecting quickfit.

FR_SERRURE BATTEUSE: Avant d'insérer la serrure batteuse, veillez à la bonne orientation avant d'insérer le raccord rapide.

ES_CIERRE DE LA CÁMARA: Cuando instale el cierre de la cámara, asegúrese de que la posición de inicio es correcta antes de que inserte el quickfit conector.

DE_CAM-LOCK: Achten Sie bei der Montage des Cam-Locks auf die richtige Ausgangsposition, bevor Sie den Quickfit einsetzen.

IT_BLOCCAGGIO A CAMMA: Quando si monta il bloccaggio a camma, assicurarsi che la posizione iniziale sia corretta prima di inserire il montaggio rapido di collegamento.

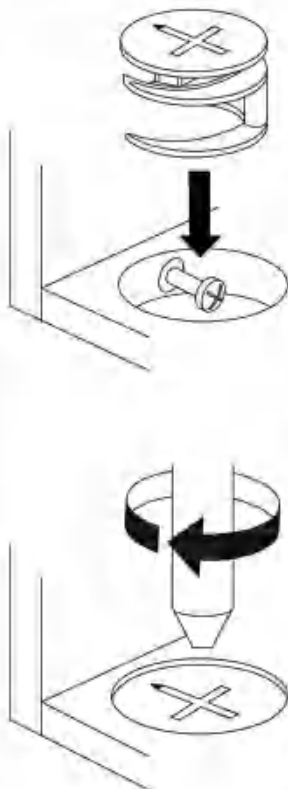

EN_Quickfit head should be in the centre of the cam lock when the two panels are joined.

Cam lock should be inserted before quickfit.

FR_Lorsque les deux panneaux sont assemblés, la tête du raccord rapide doit reposer au centre de la serrure batteuse. Il faut insérer la serrure batteuse avant le raccord rapide.

ES_El cabezal del quickfit debe estar en el centro del cierre de la cámara cuando se unan los dos paneles.

Se debe insertar el cierre de la cámara antes que el quickfit.

DE_Der Quickfit-Kopf sollte sich in der Mitte des Cam-Locks befinden, wenn die beiden Platten zusammengefügt sind.

Der Cam-Lock sollte vor dem Quickfit eingesetzt werden.

IT_La testa del montaggio rapido deve trovarsi al centro del bloccaggio a camma quando i due pannelli sono uniti.

Il Bloccaggio a Camma deve essere inserito prima del montaggio rapido.

EN_Turn cam lock clockwise to tighten.

FR_Faites tourner la serrure batteuse dans le sens des aiguilles d'une montre pour la resserrer.

ES_Gire el cierre de la cámara en sentido horario para apretarlo.

DE_Drehen Sie den Cam-Lock im Uhrzeigersinn, um ihn festzuziehen.

IT_Ruotare il bloccaggio a camma in senso orario per stringere.

EN_ It may be necessary to adjust the hinges so that the doors align. Use the instructions below as a guide.

FR_ Il est parfois nécessaire d'ajuster les charnières pour un meilleur alignement des portes. Servez-vous des instructions ci-dessous comme guide.

ES_ Puede que sea necesario ajustar los quicios de forma que se alineen las puertas. Use las instrucciones que aparecen debajo como guía.

DE_ Möglicherweise müssen Sie die Scharniere so einstellen, dass die Türen ausgerichtet sind. Verwenden Sie die nachstehenden Anweisungen als Leitfaden.

IT_ Potrebbe essere necessario regolare le cerniere in modo che le porte siano allineate. Per fare ciò attenersi alle istruzioni sottostanti.

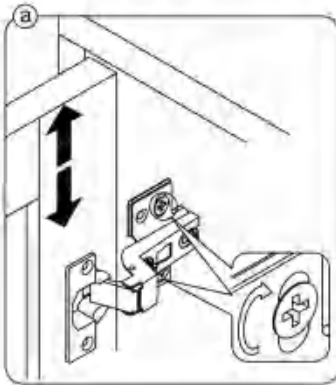

EN_ To adjust the door vertically loosen the screw as shown and move up and down as needed.

FR_ Si vous souhaitez régler la porte **verticalement**, desserrez la vis comme indiqué et déplacez la porte de haut en bas selon les besoins.

ES_ Para ajustar la puerta **verticalmente** afloje el tornillo tal y como se muestra y muévalo hacia arriba o hacia abajo según sea necesario.

DE_ Um die Tür **vertikal** auszurichten, lösen Sie die Schraube wie abgebildet und bewegen Sie sie nach Bedarf nach oben oder nach unten.

IT_ Per allineare la porta **verticalmente** allentare la vite come mostrato e spostarla in alto o in basso secondo necessità.

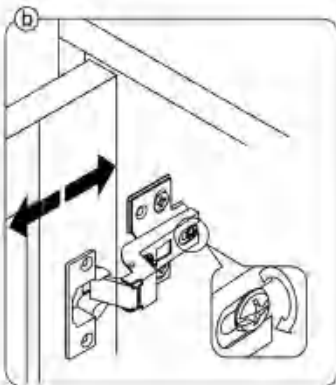

EN_ To adjust the gap from the door to the main frame turn the screw clockwise or anti-clockwise as needed.

FR_ Si vous souhaitez ajuster l'**écart** entre la porte et le cadre principal, tournez la vis dans le sens des aiguilles d'une montre ou dans le sens inverse, si nécessaire.

ES_ Para ajustar el **espacio** desde la puerta al marco principal, gire el tornillo en sentido horario o antihorario, según se necesite.

DE_ Um den **Abstand** von der Tür zum Hauptrahmen auszurichten, drehen Sie die Schraube je nach Bedarf im oder gegen den Uhrzeigersinn.

IT_ Per regolare lo **spazio** tra la porta e il telaio principale, avvitare o svitare la vite secondo necessità.

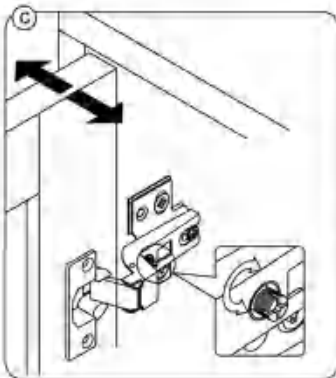

EN_ To adjust the door laterally adjust the screw as shown by turning clockwise or anti-clockwise.

FR_ Si vous souhaitez ajuster la porte **latéralement**, ajustez la vis comme indiqué en tournant dans le sens des aiguilles d'une montre ou dans le sens inverse des aiguilles d'une montre.

ES_ Para ajustar la puerta **lateralmente** ajuste el tornillo tal y como se muestra girándolo en sentido horario y antihorario.

DE_ Um die Tür **seitlich** auszurichten, stellen Sie bitte die Schraube wie abgebildet durch Drehen im oder gegen den Uhrzeigersinn ein.

IT_ Per allineare la porta **lateralmente** regolare la vite come mostrato, avvitandola o svitandola.

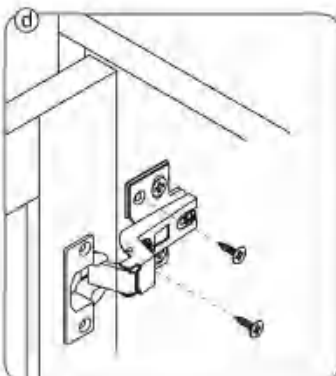

EN_ Please fix other screws

FR_ Merci de serrer les autres vis.







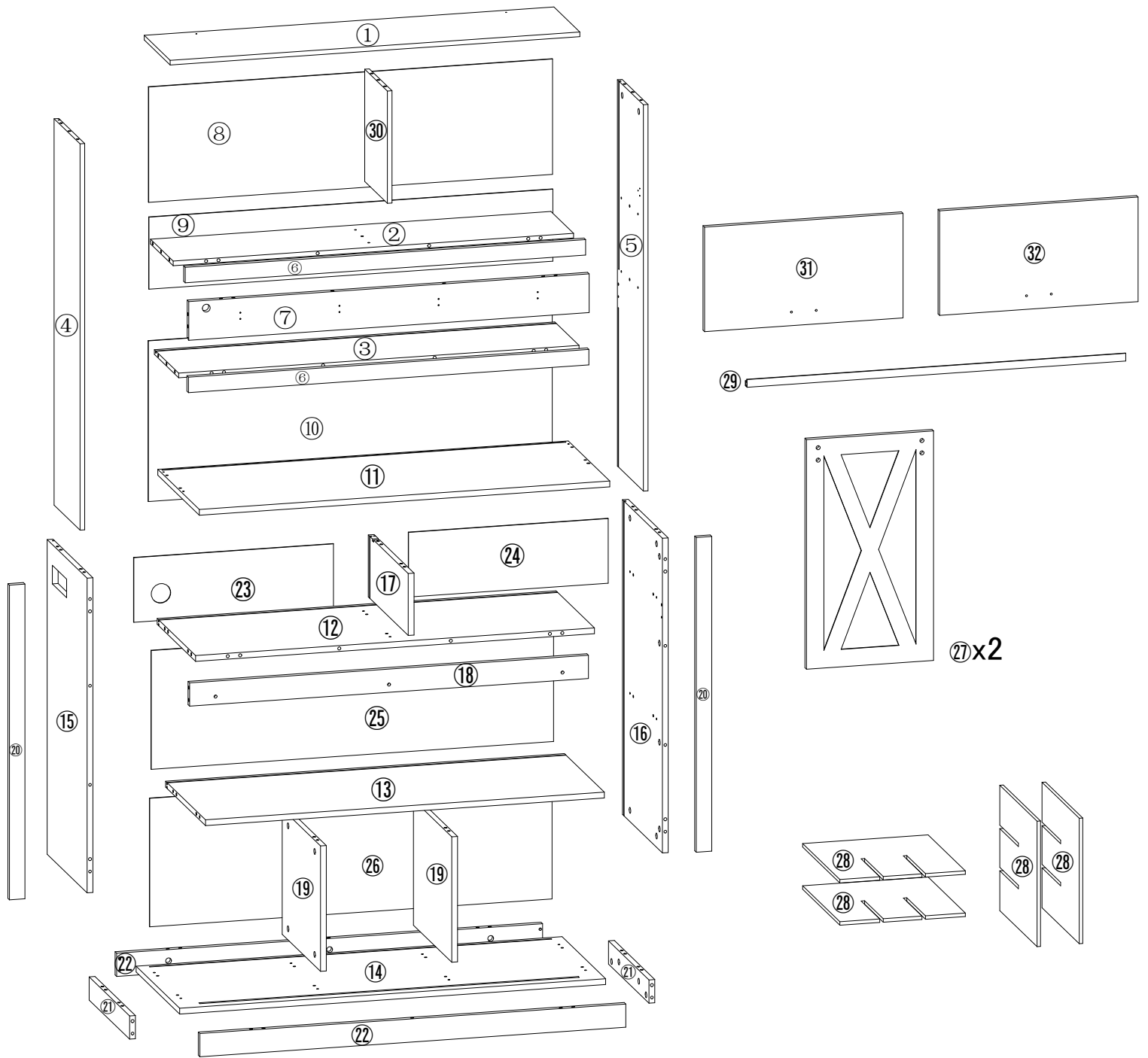



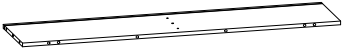

ES_ Fije los demás tornillos

DE_ Befestigen Sie bitte die anderen Schrauben









IT_ Fissare le altre viti

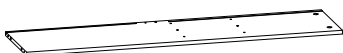



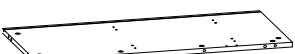



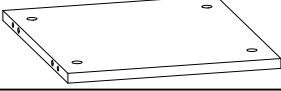

N635P466403 - Box:1/3





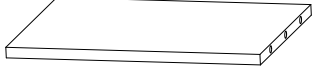

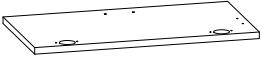



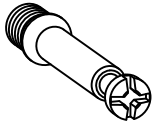



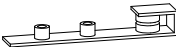



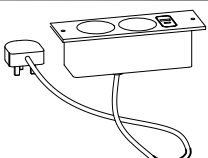

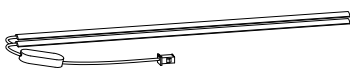

			
① x 1pc	② x 1pc	③ x 1pc	⑥ x 2pcs
			
⑦ x 1pc	⑧ x 1pc	⑨ x 1pc	⑩ x 1pc
			
⑪ x 1pc	⑭ x 1pc	⑳ x 2pcs	㉕ x 1pc
			
㉖ x 1pc			

N635P466404 - Box:2/3

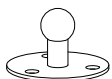
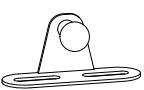

			
④ x 1pc	⑤ x 1pc	⑫ x 1pc	⑬ x 1pc
			
⑮ x 1pc	⑯ x 1pc	⑱ x 1pc	㉐ x 2pcs
			
㉑ x 1pc			

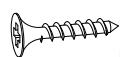
			
①7 x 1pc	①9 x 2pcs	②1 x 2pcs	②3 x 1pc
			
②4 x 1pc	②7 x 2pcs	②8 x 4pcs	③0 x 1pc
			
③1 x 1pc	③2 x 1pc		

Hardware-Liste :N635P466405- Box:3/3

 M6x35mm	 Φ15x9mm	 Φ6x30mm	 M6x12mm
A x 86pcs	B x 86pcs	C x 68pcs	D x 8pcs
			 M3x16mm
F x 4pcs	G x 10pcs	H x 4pcs	I x 42pcs
			
J x1pc	K x 1pc	M x 2pcs	N x 4pcs
 M4x14mm			
O x 34pcs	P x 2pcs	Qx 28pcs	R x 1 pc
			 M6x25mm
S x 1 pc	U x 12pcs	V x 4 pcs	W x 3 pcs
		 M4x18mm	 M3x12mm
X x 2 pcs	Y x 2 pcs	Z x 4 pcs	Aa x 6 pcs
 M3x12mm	 M4x45mm		
Bb x 6 pcs	Cc x 4 pcs	Dd x 1 pc	

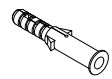
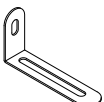
Prevent dumping of spare parts+ N639P466405 - Box:3/3

		 M4x14mm	 M4x35mm
E x 2pcs	L x 2pcs	O x 2pcs	T x 2pcs

1.

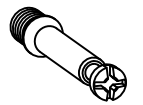
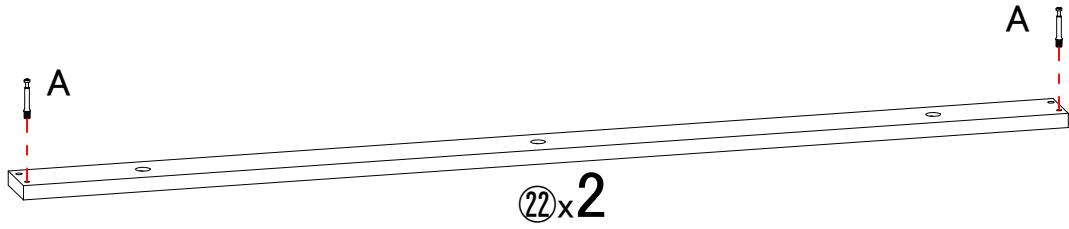

A x 4pcs

2.

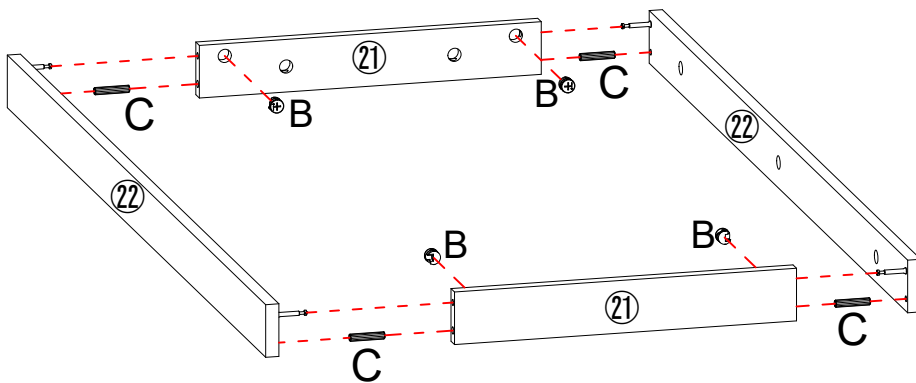

B x4pcs



C x 4pcs

3.

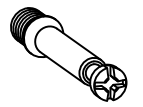
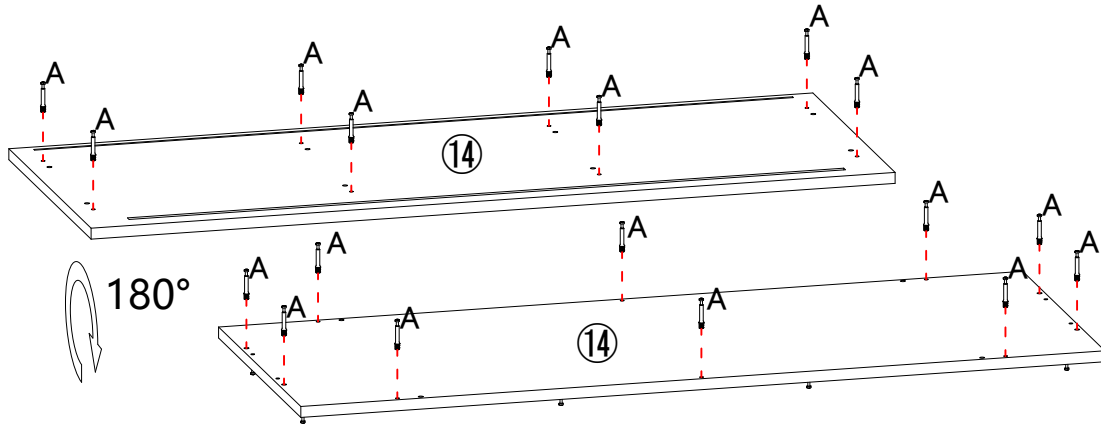

A x 18pcs

4.

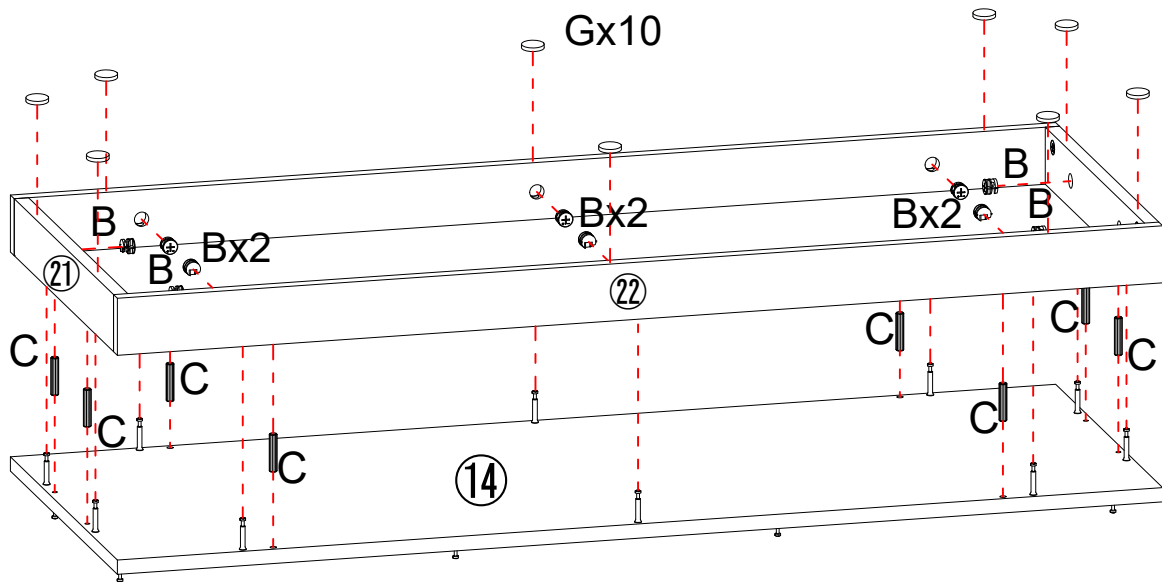

B x 10pcs





C x 8pcs

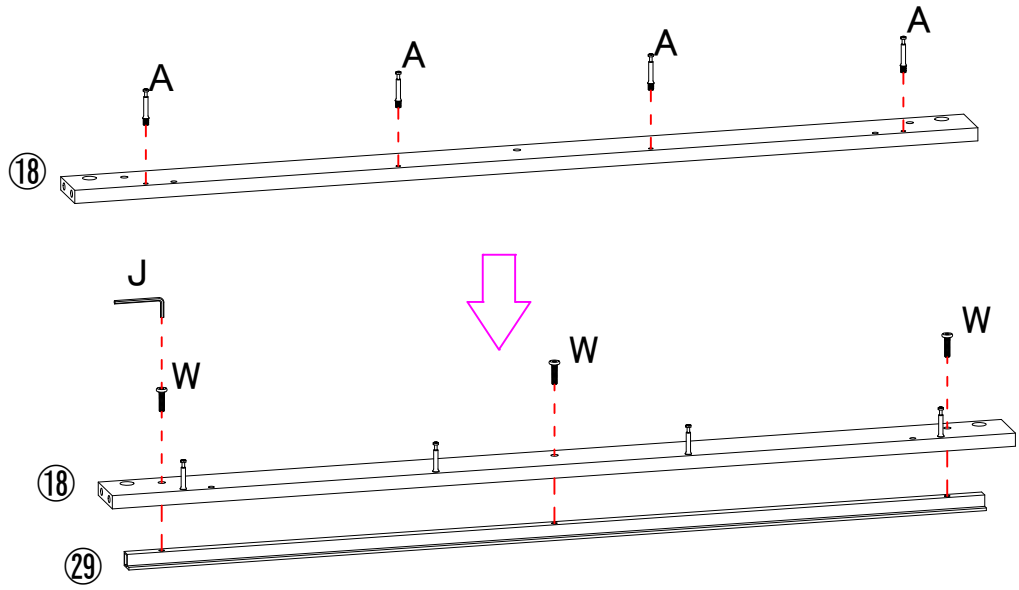

G x 10pcs

5.

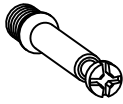

		
A x 4pcs	W x 3pcs	J x 1pc

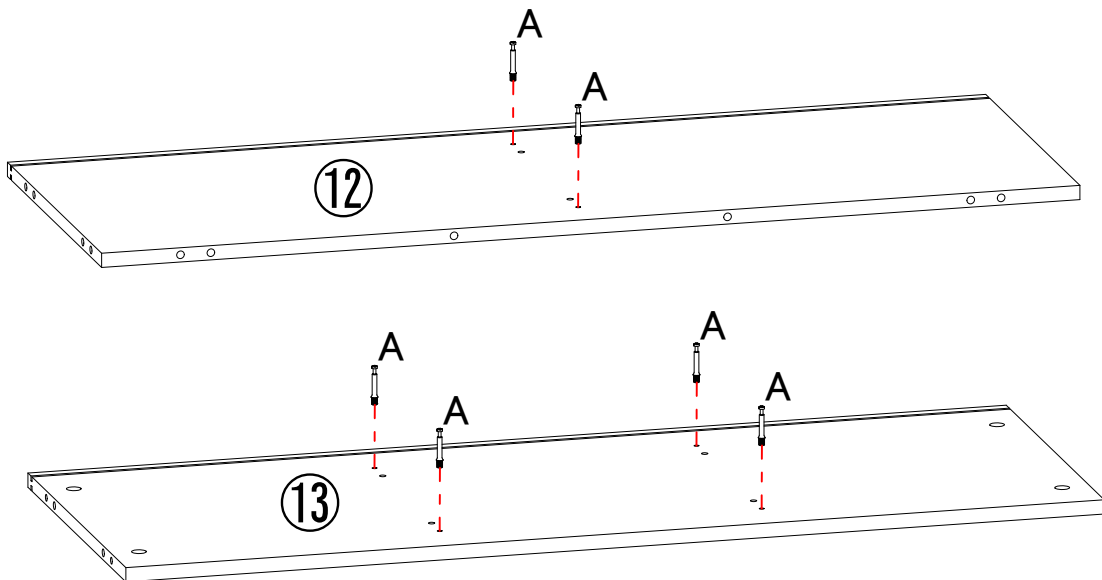

6.

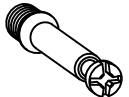

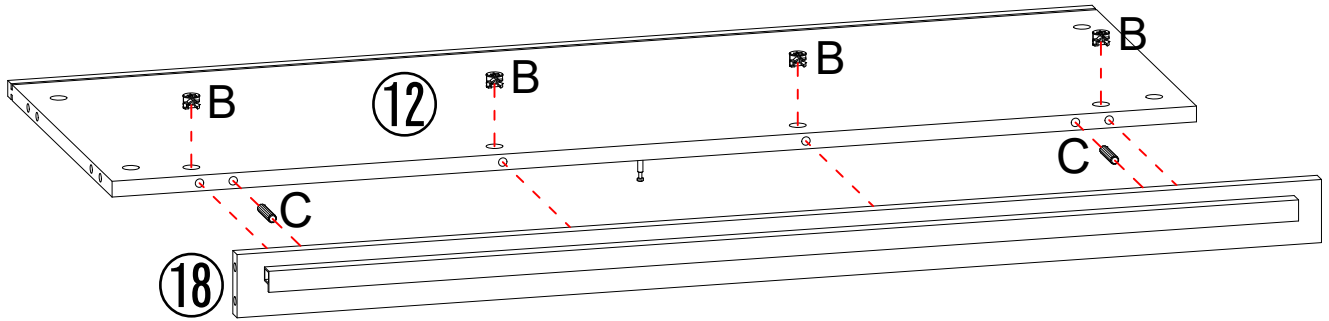

A x 6pcs

7.



	
B x4pcs	C x 2pcs

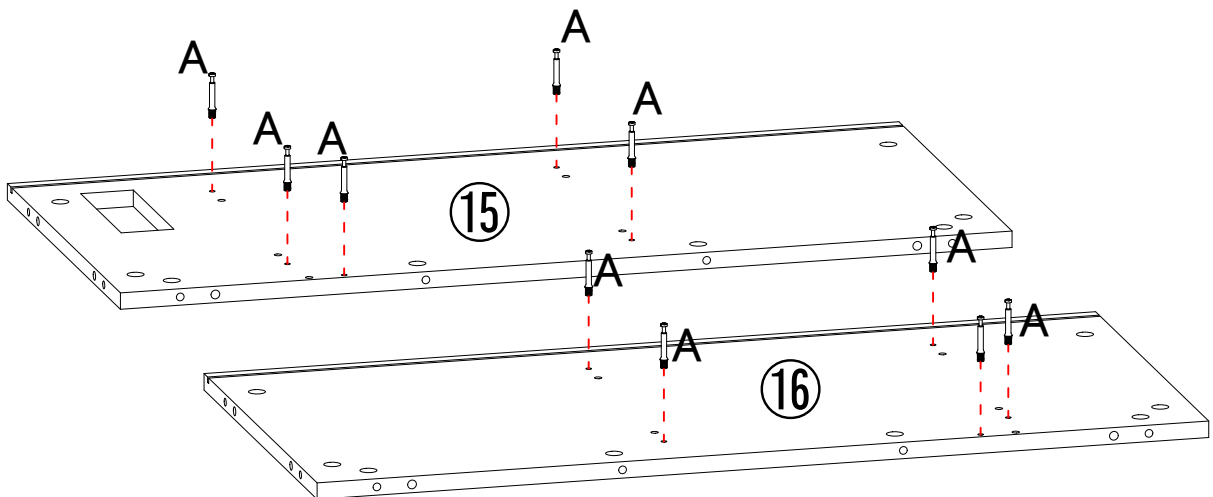

8.

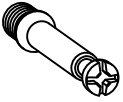

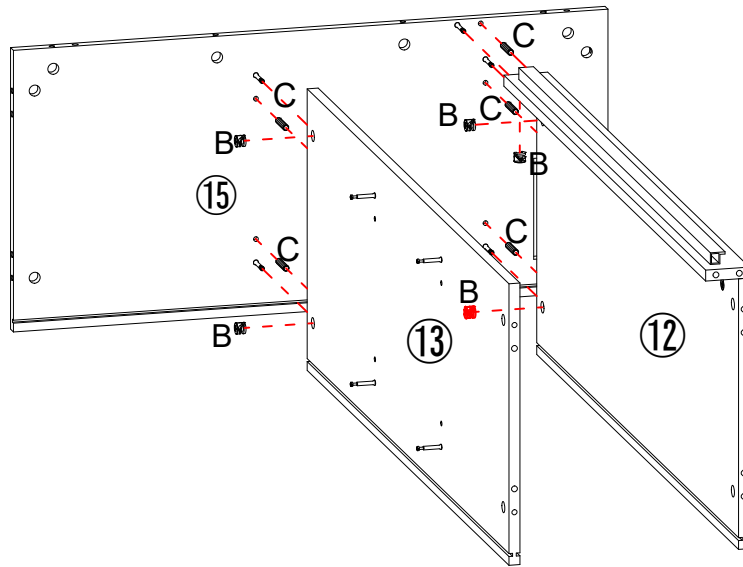

A x 10pcs

9.



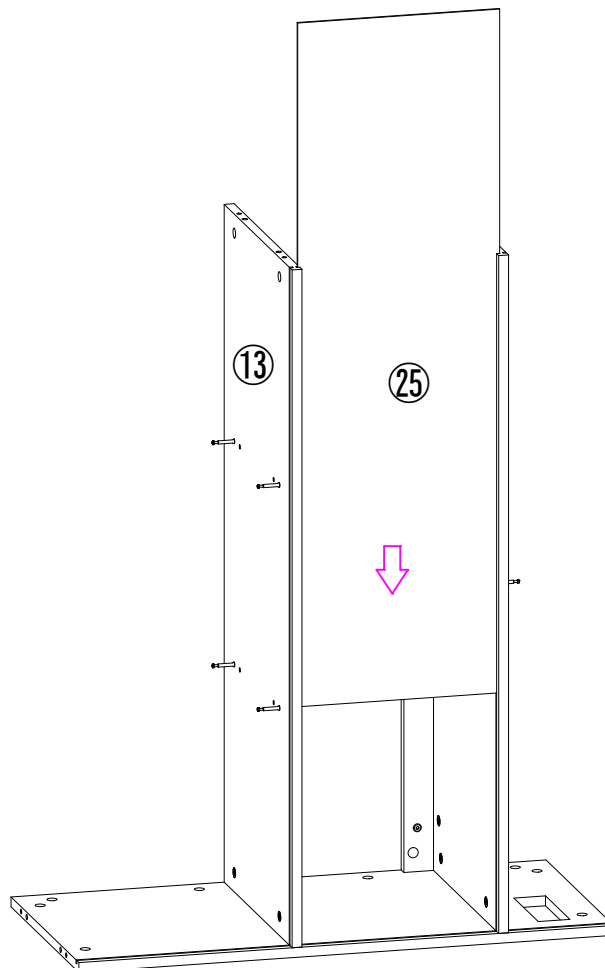

	
B x5pcs	C x 5pcs

10.



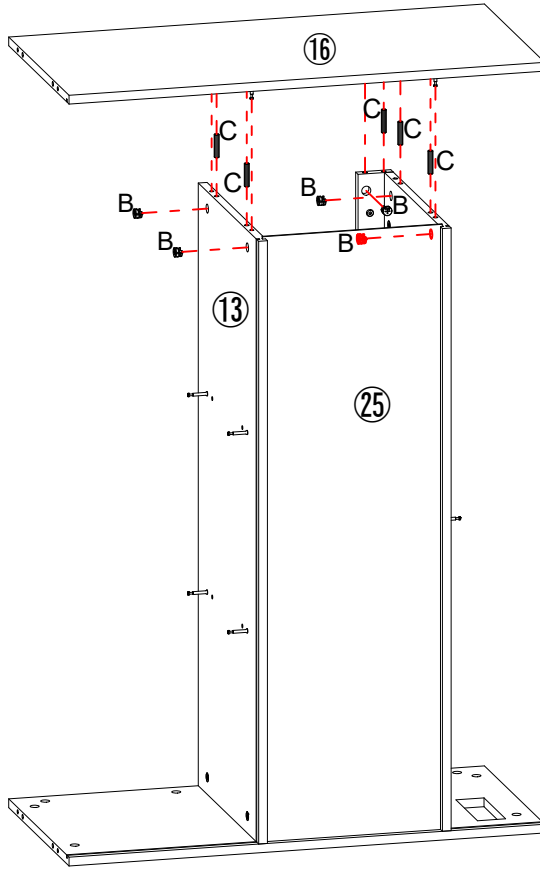

11.

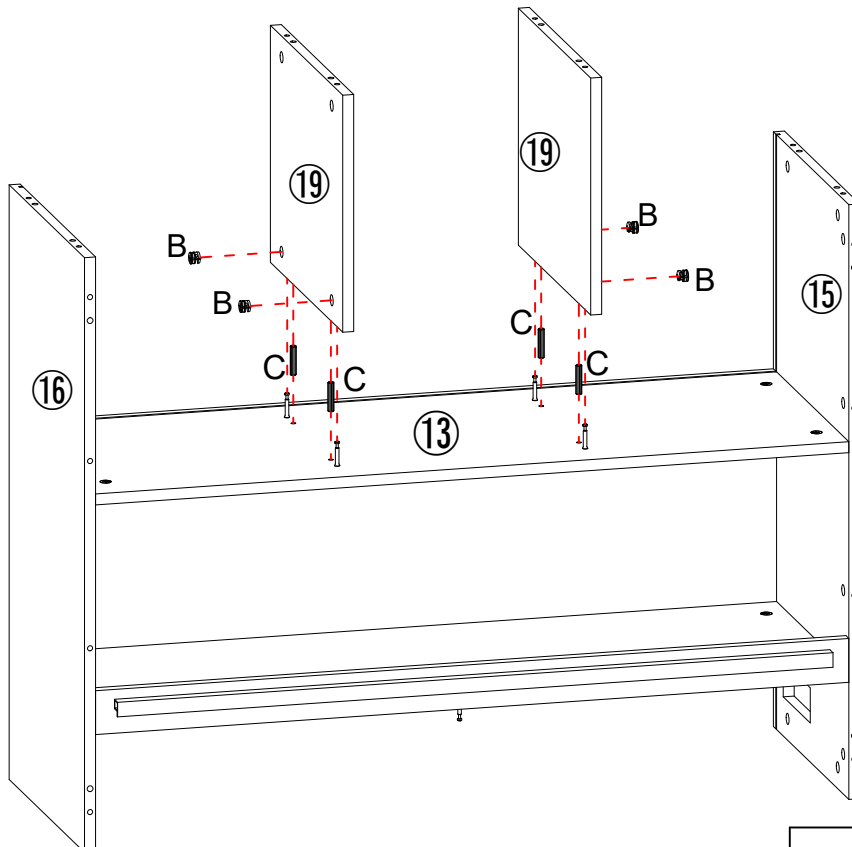

	
B x5pcs	C x 5pcs

12.



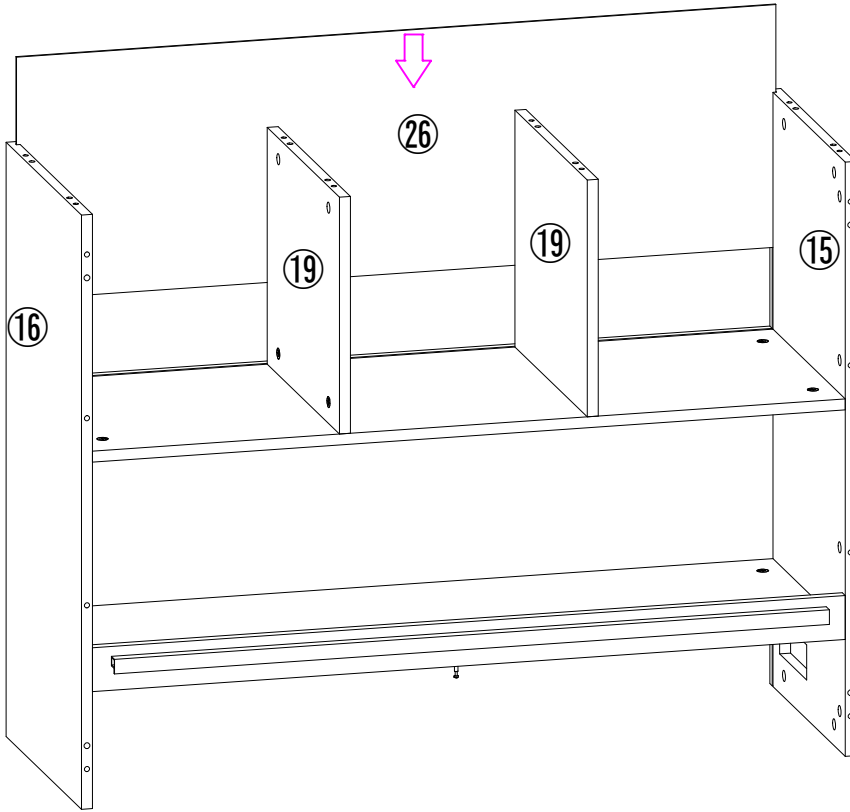

	
B x4pcs	C x 4pcs

13.

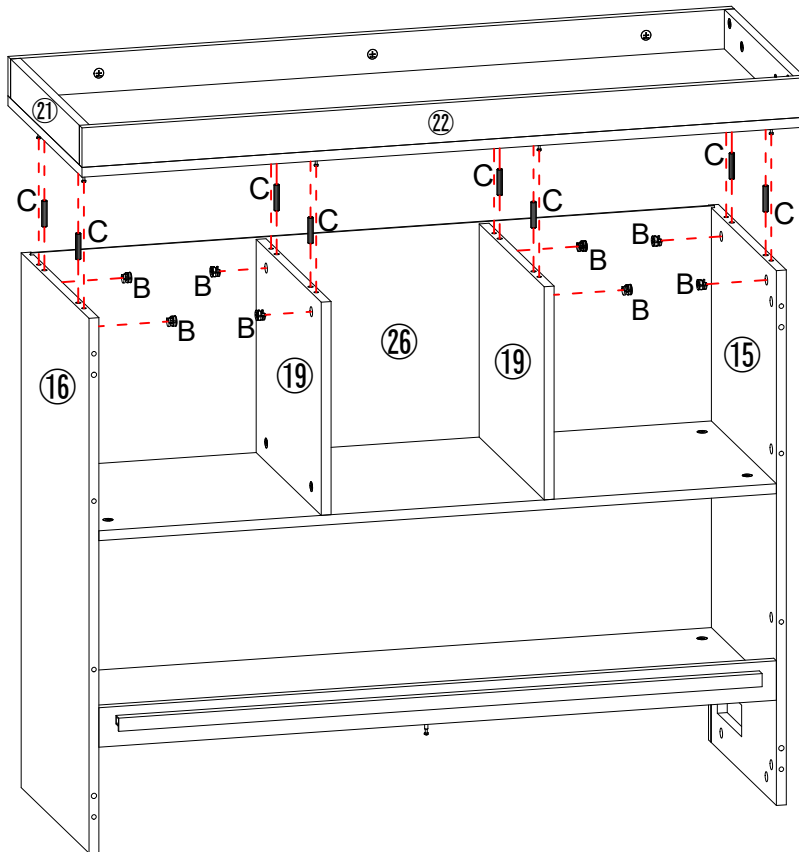

14.



	
B x 8pcs	C x 8pcs

15.

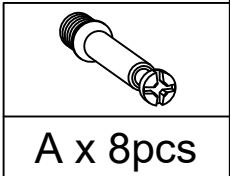
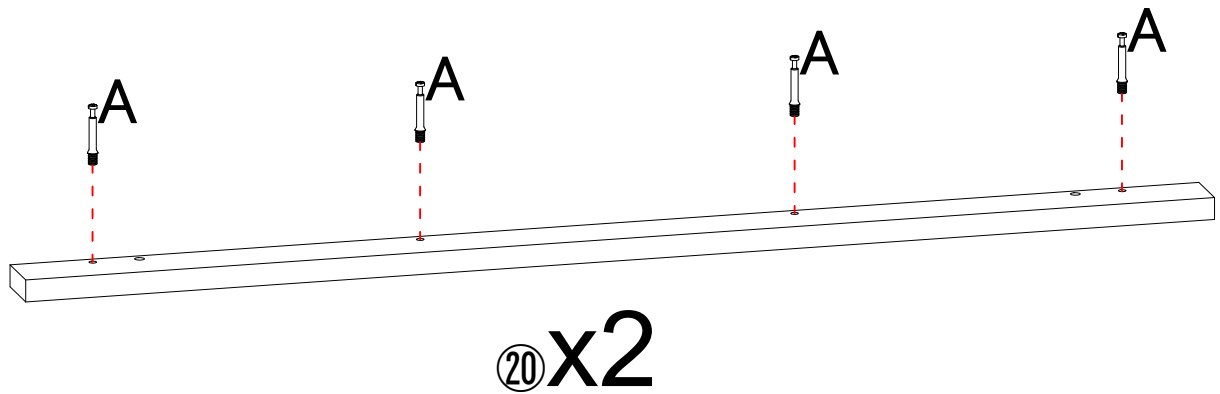

16.

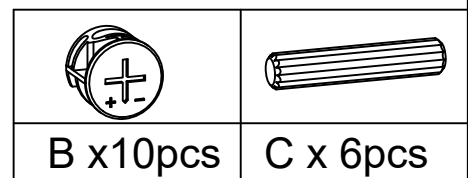
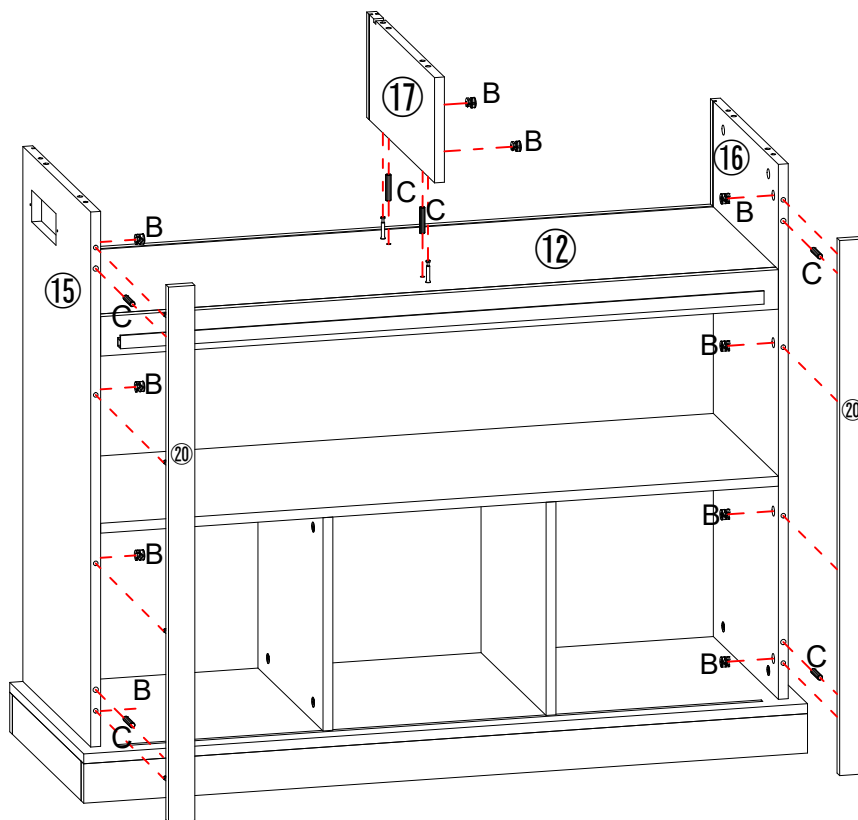

17.

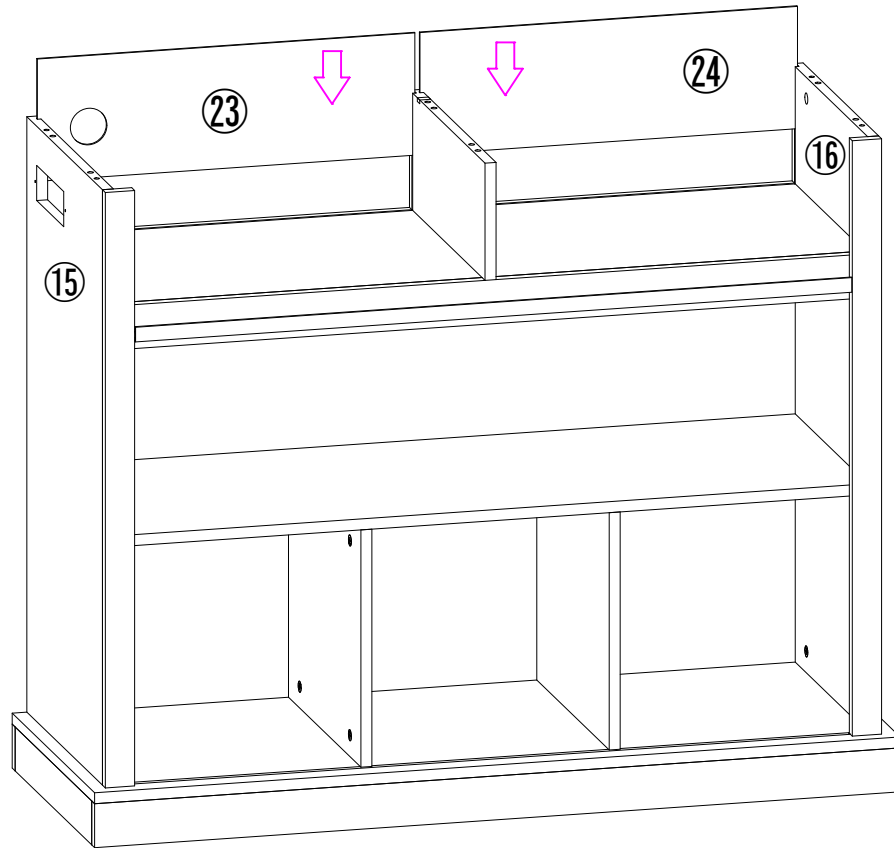

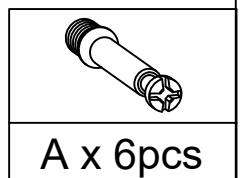
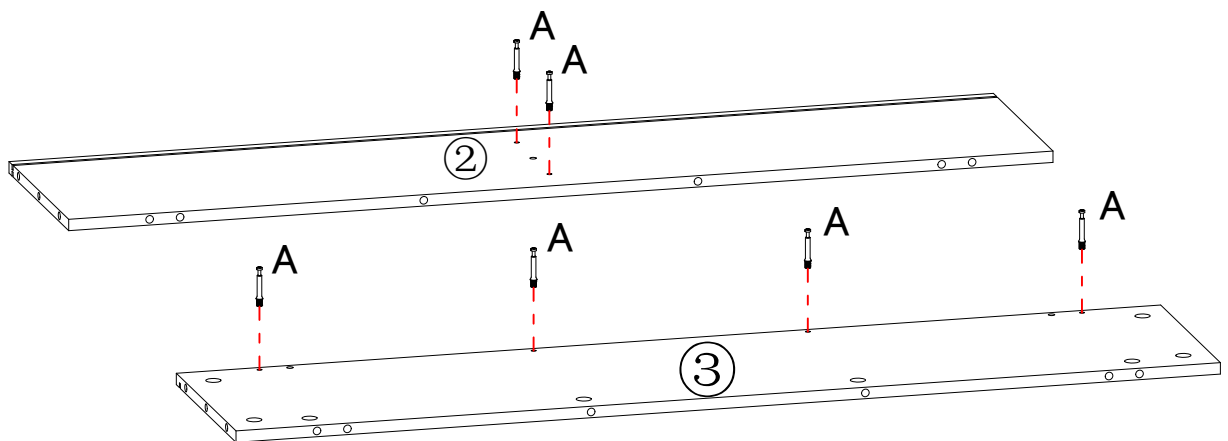

18.



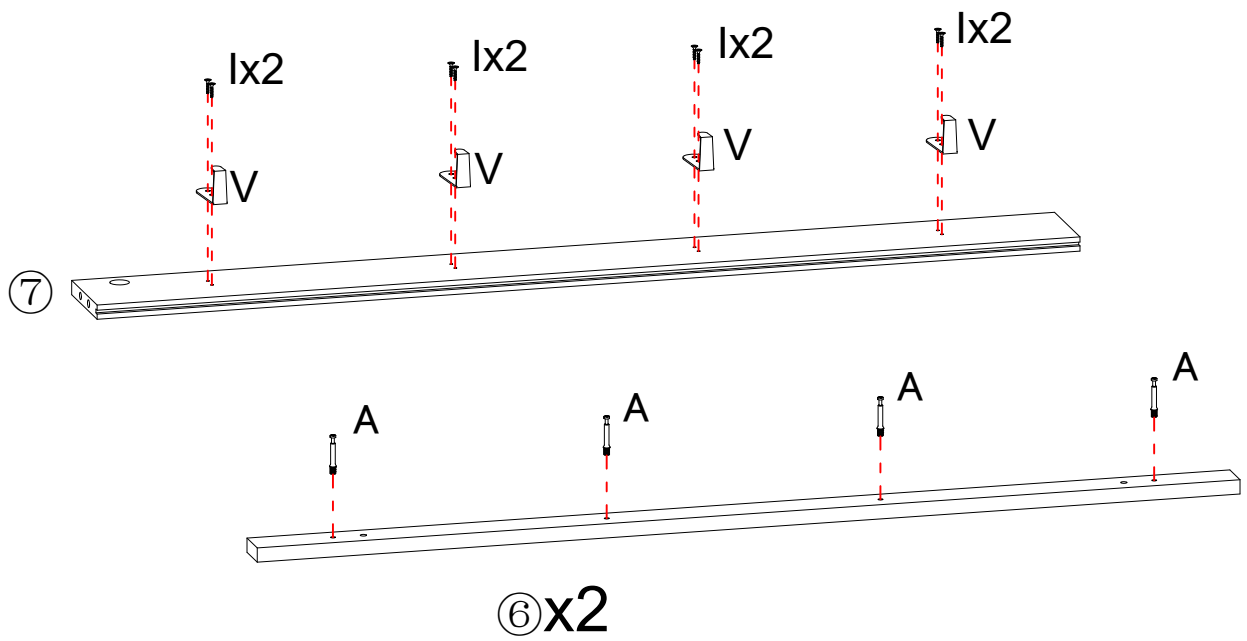

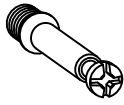
19.



		
A x 8 pcs	I x 8 pcs	V x 4 pcs

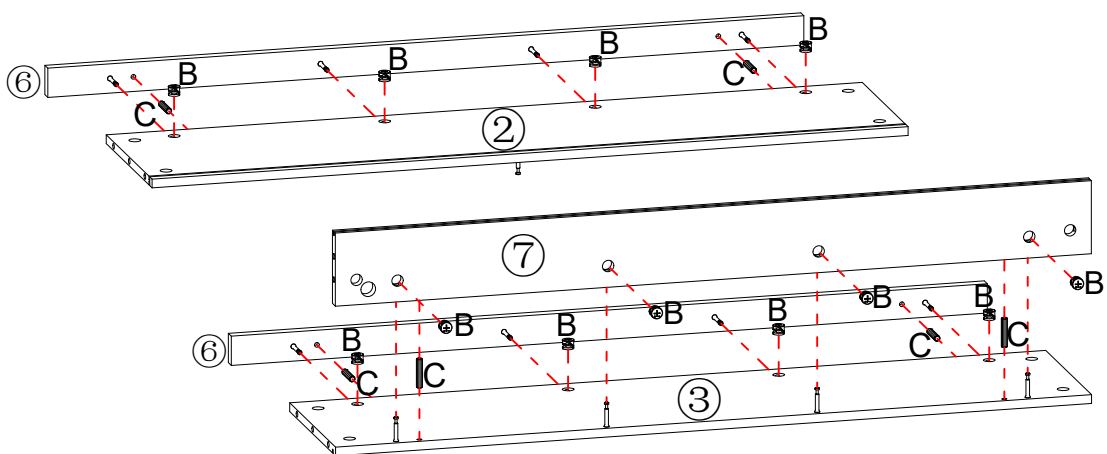

20.



	
B x 12 pcs	C x 6 pcs

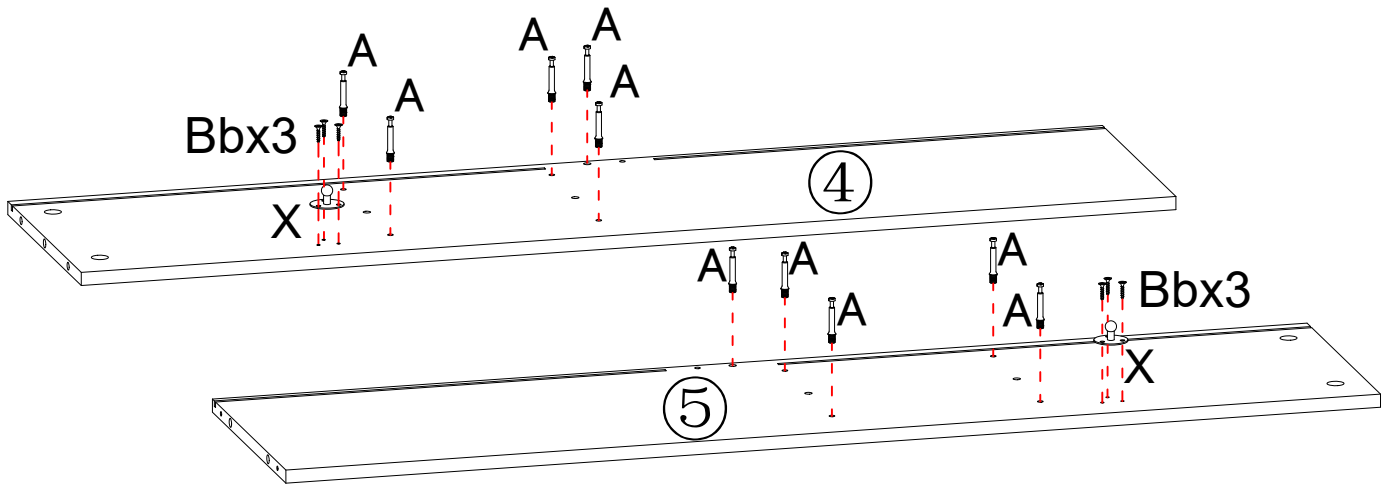

21.

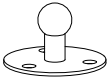

	 M3*12mm	
A x 10pcs	Bb x 6pcs	Xx 2pcs

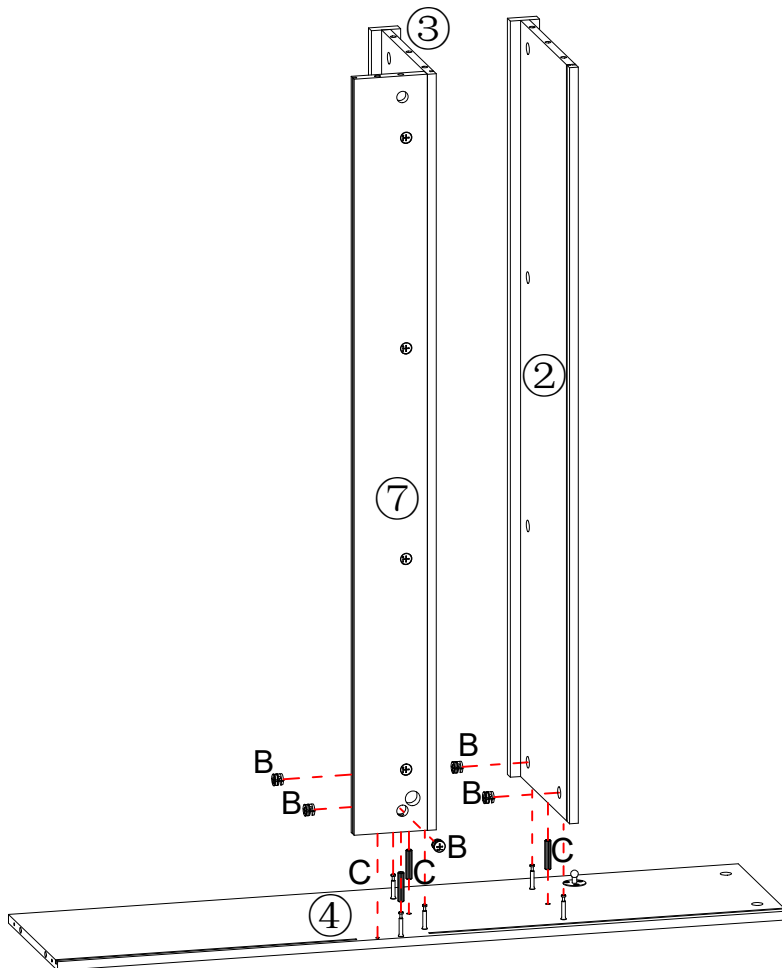
22.



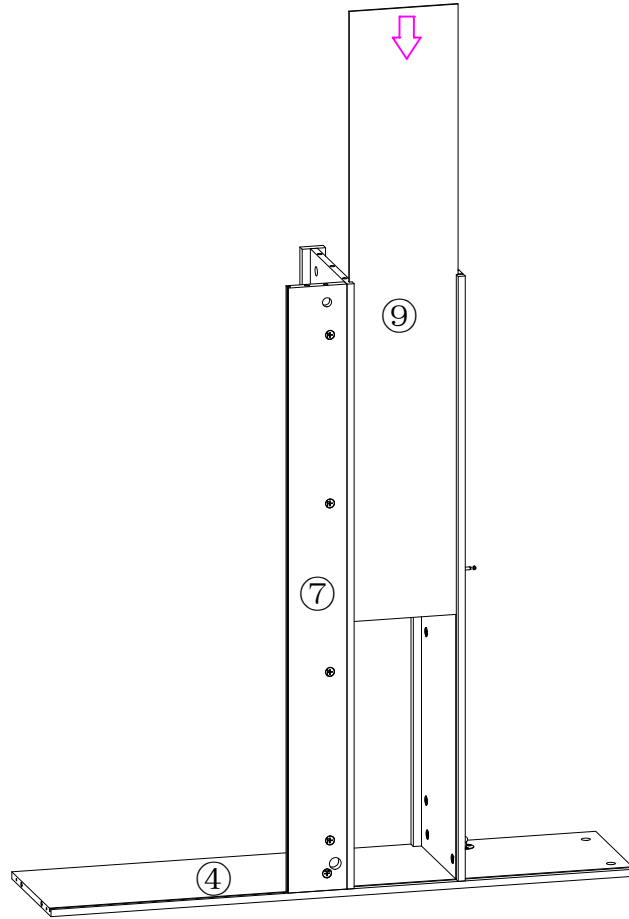

	
B x 5pcs	C x 3pcs

23.

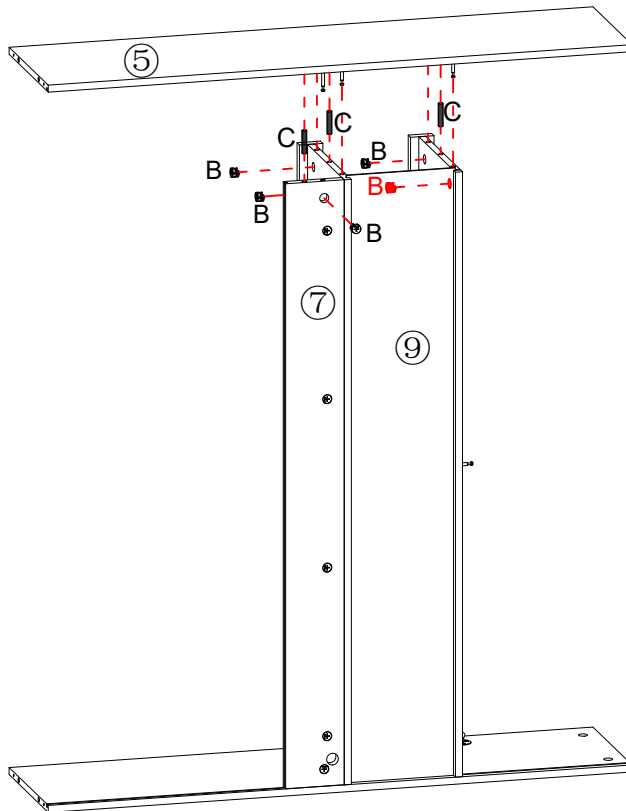

24.



	
B x5pcs	C x 3pcs

25.

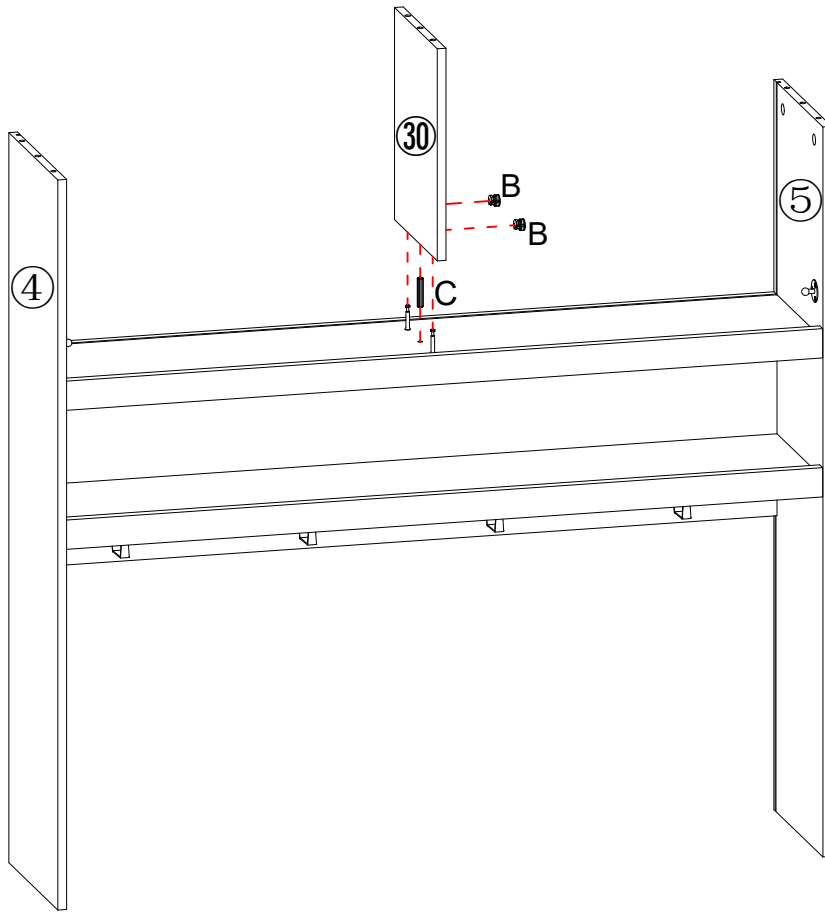

B x2pcs



C x 1pc

26.

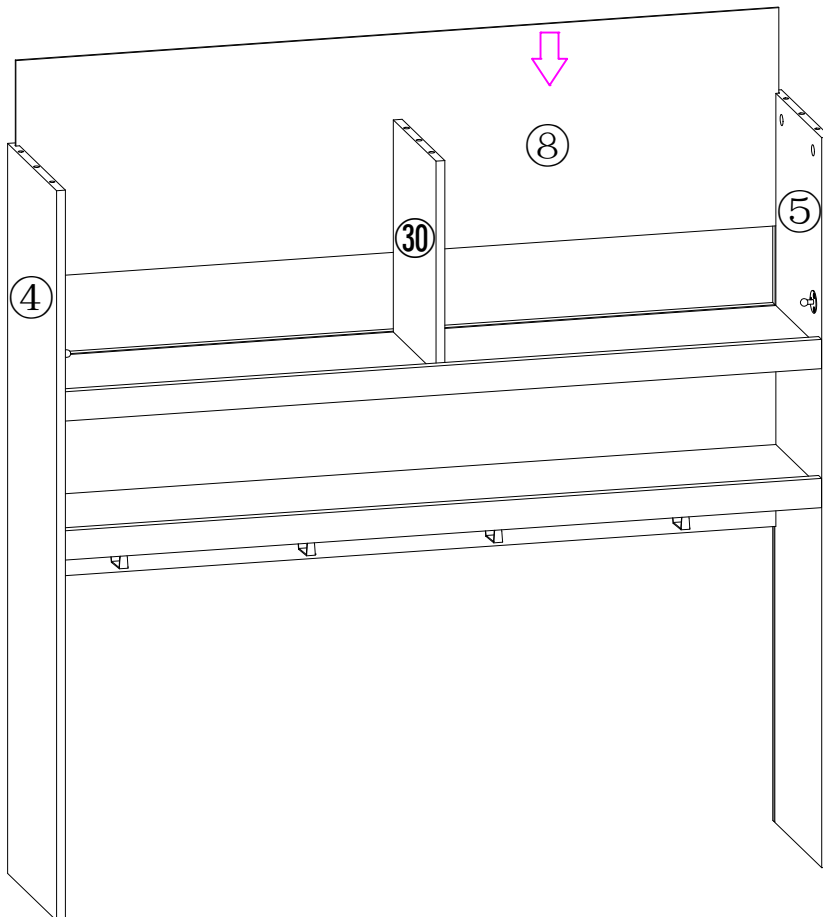

27.

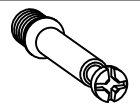
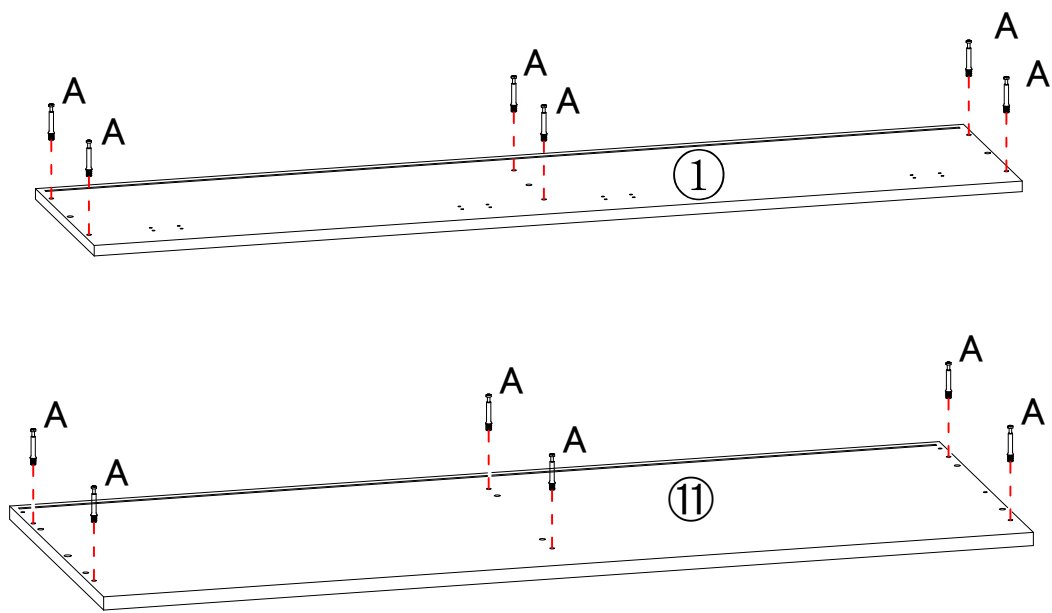

A x 12pcs

28.

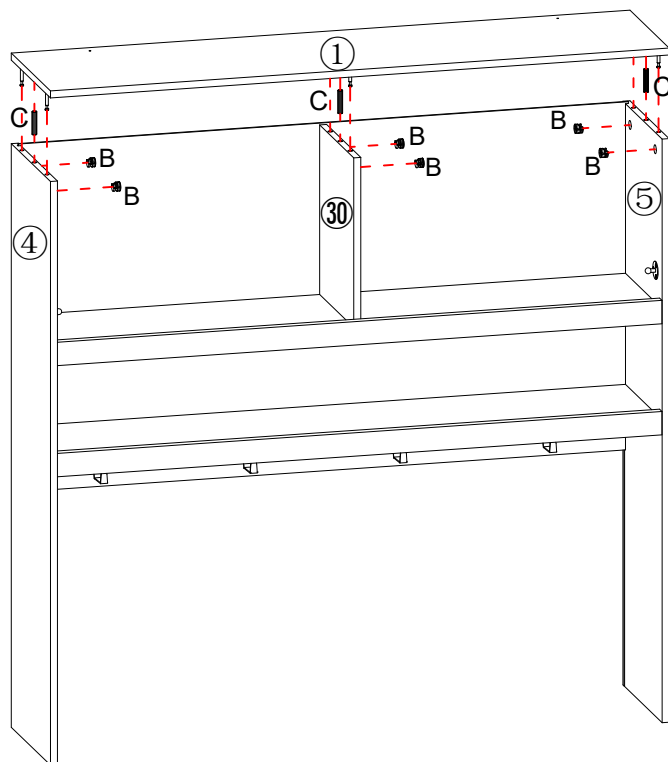

B x 6pcs



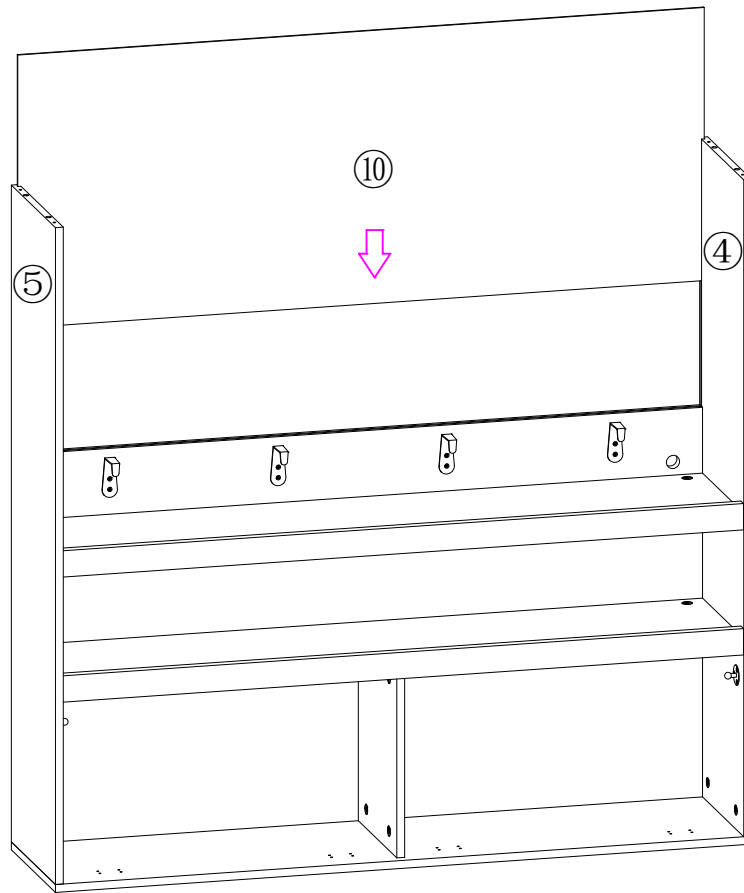

C x 3pcs

29.



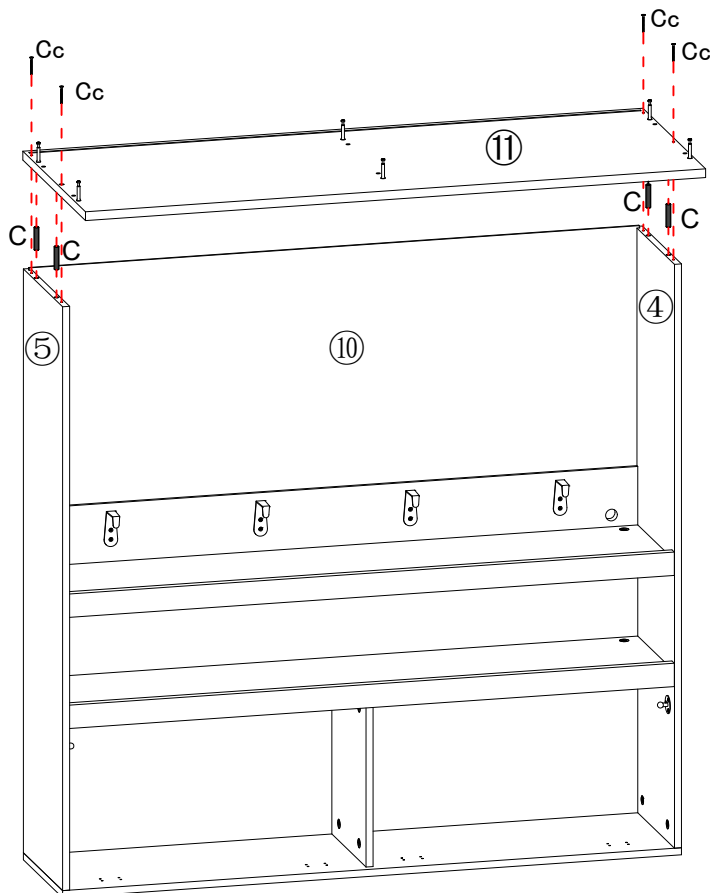

30.

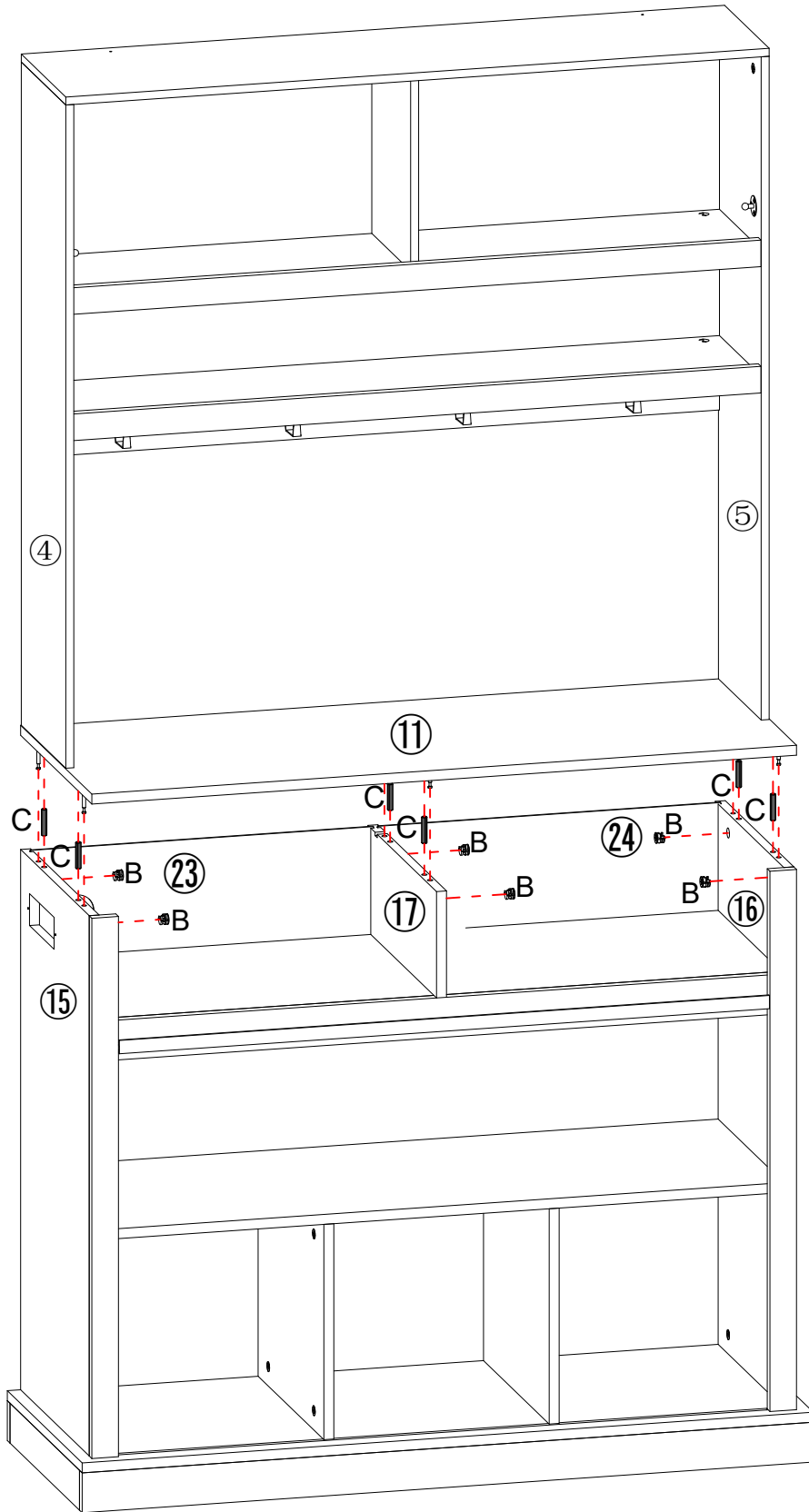

	
C x 4pc	Cc x 4pcs

31.



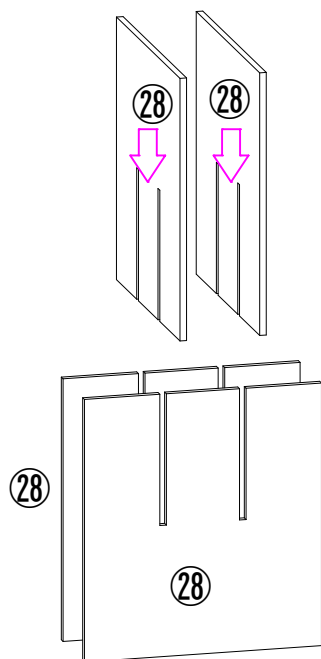

	
B x6pcs	C x 6pcs

32.

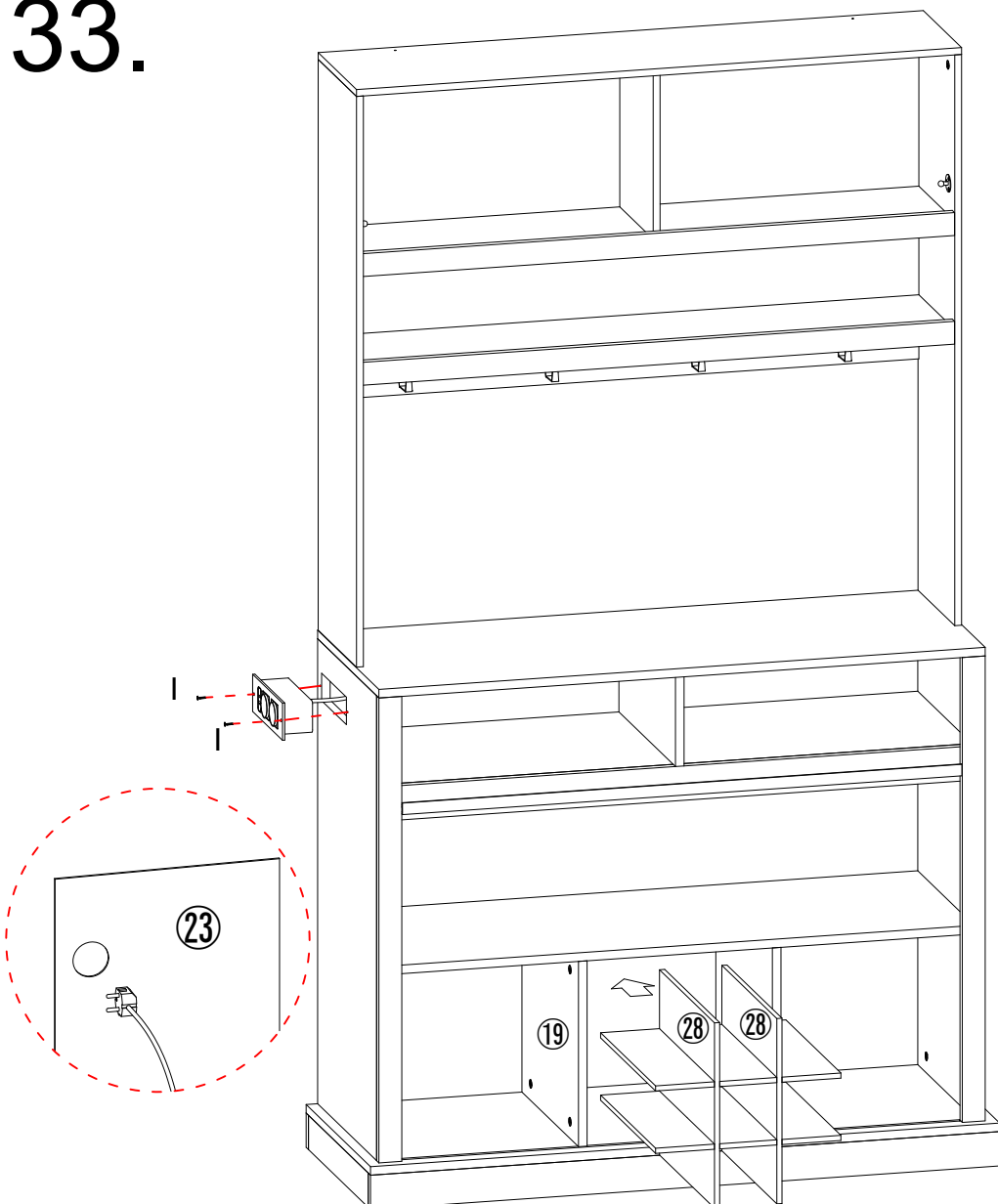

33.

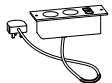

	
I x2pcs	K x 1pc

34.

DE: Durchdringen Sie die beiden Lampenbänder durch die Löcher 7 und 23, reißen Sie dann die Membran hinter dem Lampenbänder ab und kleben Sie an den Boden der Teile 3 und 11 und befestigen Sie es mit dem Zubehör Aa.





UK: Thread two light strips through holes 7 and 23 respectively, then tear off the film behind the light strips and stick them to the bottom of parts 3 and 11, and fix them with accessory Aa.

FR: Les deux rubans lumineux sont percés de trous dans les pièces 7 et 23 respectivement, puis le film derrière le ruban lumineux est arraché et collé au fond des pièces 3 et 11, puis la ferrure Aa est fixée.

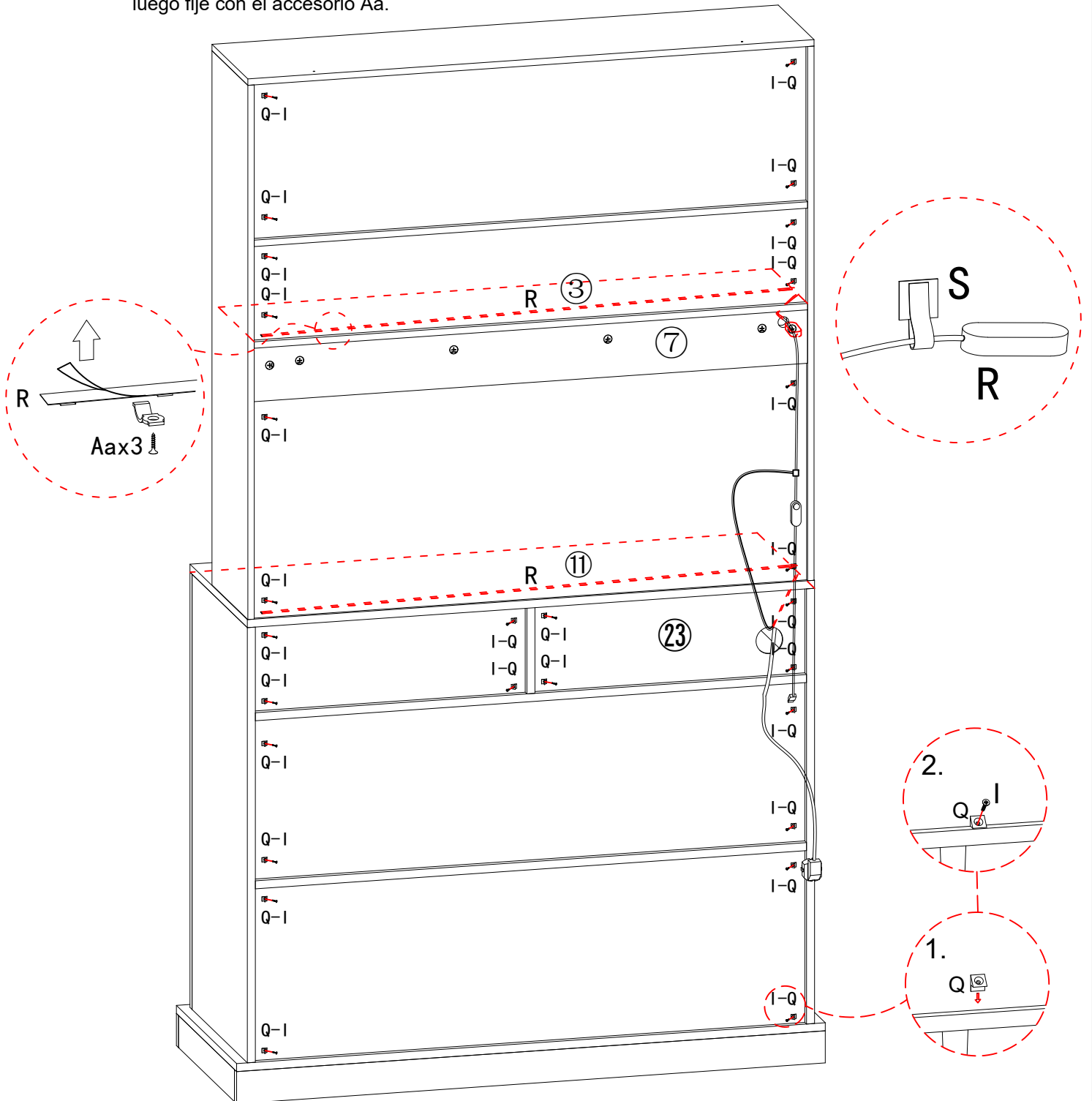

IT: Inserire due nastri di luce attraverso i fori dei componenti 7 e 23, quindi strappare la membrana dietro il nastro di luce incollata alla parte inferiore dei componenti 3 e 11 e fissare con l'accessorio Aa.

ES: Introduzca las dos cintas de luz a través de los agujeros 7 y 23 de los componentes, respectivamente, y luego rompa la película detrás de las cintas de luz y pegue en la parte inferior de los componentes 3 y 11, y luego fije con el accesorio Aa.

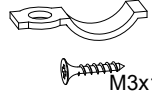

				
I x 28pcs	Q x 28pcs	R x 1pc	S x 1pc	Aa x 3pcs

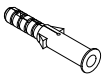
35.

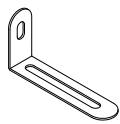
	 M4x35mm
E x 2pcs	T x 2pcs
 M4x14mm	
O x 2pcs	L x 2pcs

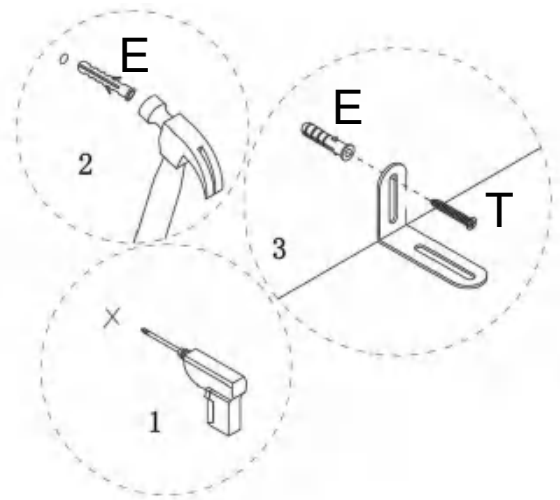
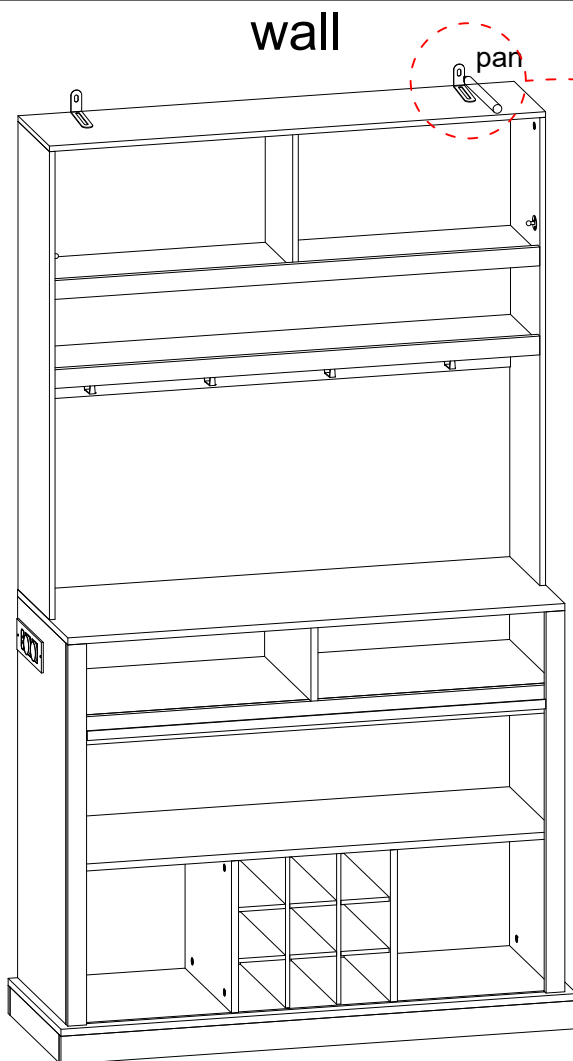
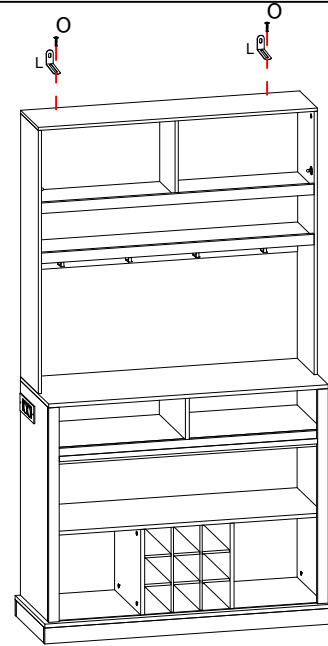

DE:ACHTUNG: Zur Sicherheit und Stabilität empfehlen wir Ihnen, die Kippsicherungszubehör an der Wand zu befestigen, um ein Umkippen, Verletzungen und Sachschäden zu verhindern.

UK:ATTENTION: For safety and stability, we suggest you have to secure the anti tip accessories to the wall to prevent tipping, injury, and property damage.

FR:ATTENTION : Pour la sécurité et la stabilité, nous vous recommandons de fixer les accessoires anti-basculement au mur afin d'éviter tout renversement, blessure et dommage matériel.

IT:ATTENZIONE: Per garantire sicurezza e stabilità, ti consigliamo di fissare gli accessori di sicurezza contro il ribaltamento alla parete, per prevenire ribaltamenti, lesioni e danni materiali.

ES:ATENCIÓN: Para garantizar seguridad y estabilidad, le recomendamos que fije los accesorios de seguridad contra el vuelco a la pared para prevenir vuelcos, lesiones y daños materiales.

36.

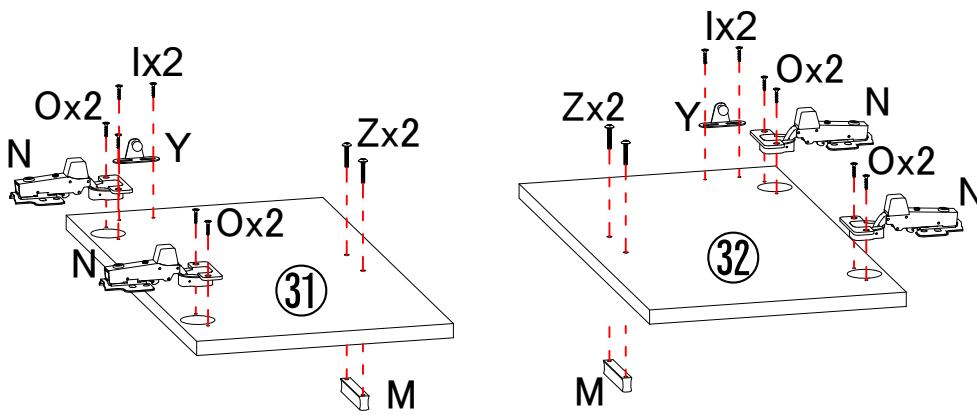

N x 4pcs	M3x16 I x 4pcs	M4x14 O x 8pcs	Y x 2pcs	Z x 4pcs	M x 2pcs

37.

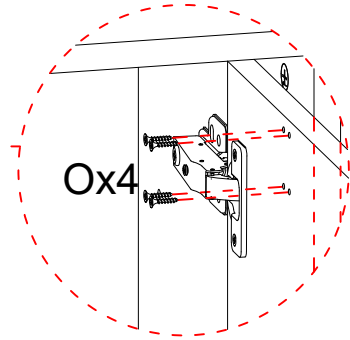
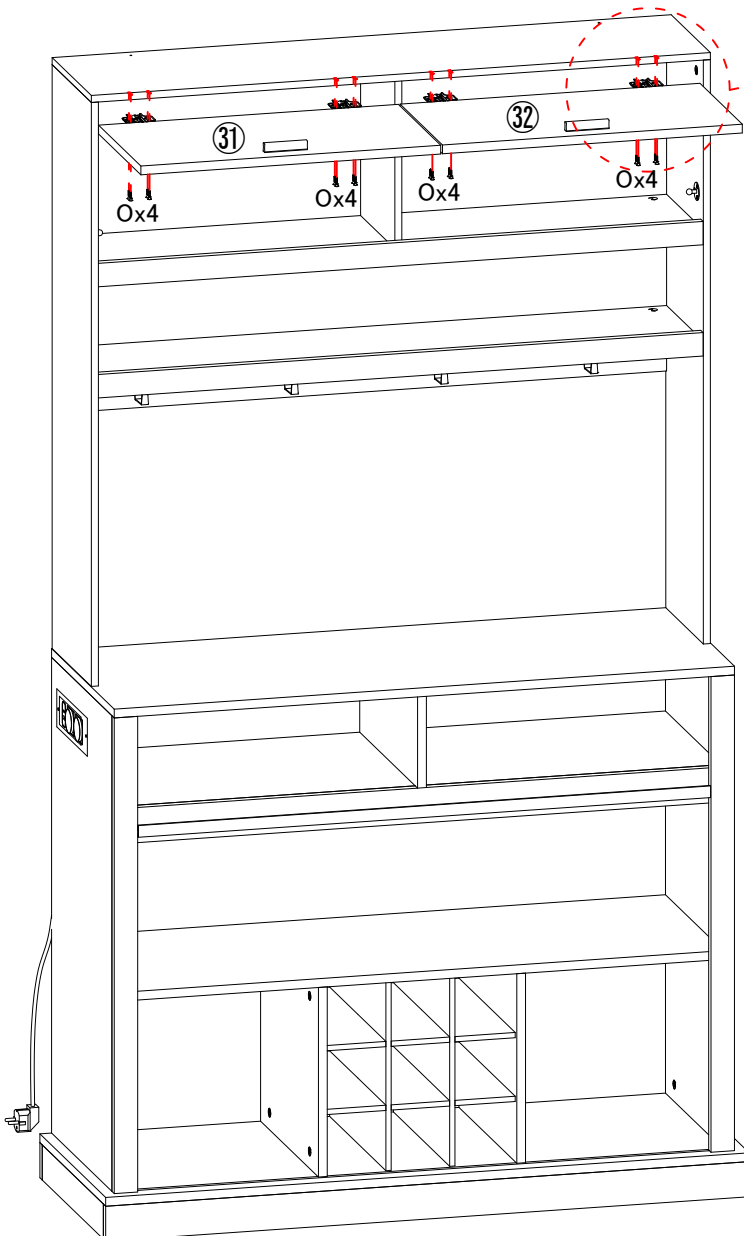

1 Sideways / Tilt adjustment

Turn the screw clockwise to move the door further away from the side of the cabinet
anticlockwise to move the door closer to the side of the cabinet

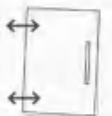

2 Height adjustment

While supporting the weight of the door, turn the screws clockwise to move the door up
anticlockwise to move the door down

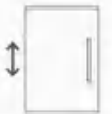

3 Forward and back adjustment

If the gap between the back of the door and the cabinet is too small, and the door may not close fully. Turn the screw clockwise to decrease the gap between the door and the cabinet
anticlockwise to increase the gap between the door and the cabinet



M4x14mm

O x 16pcs

38.

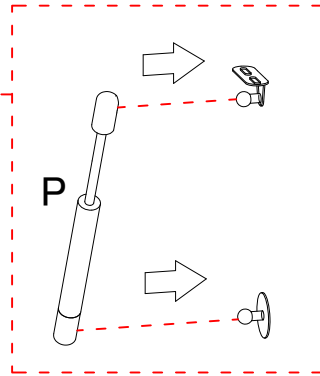
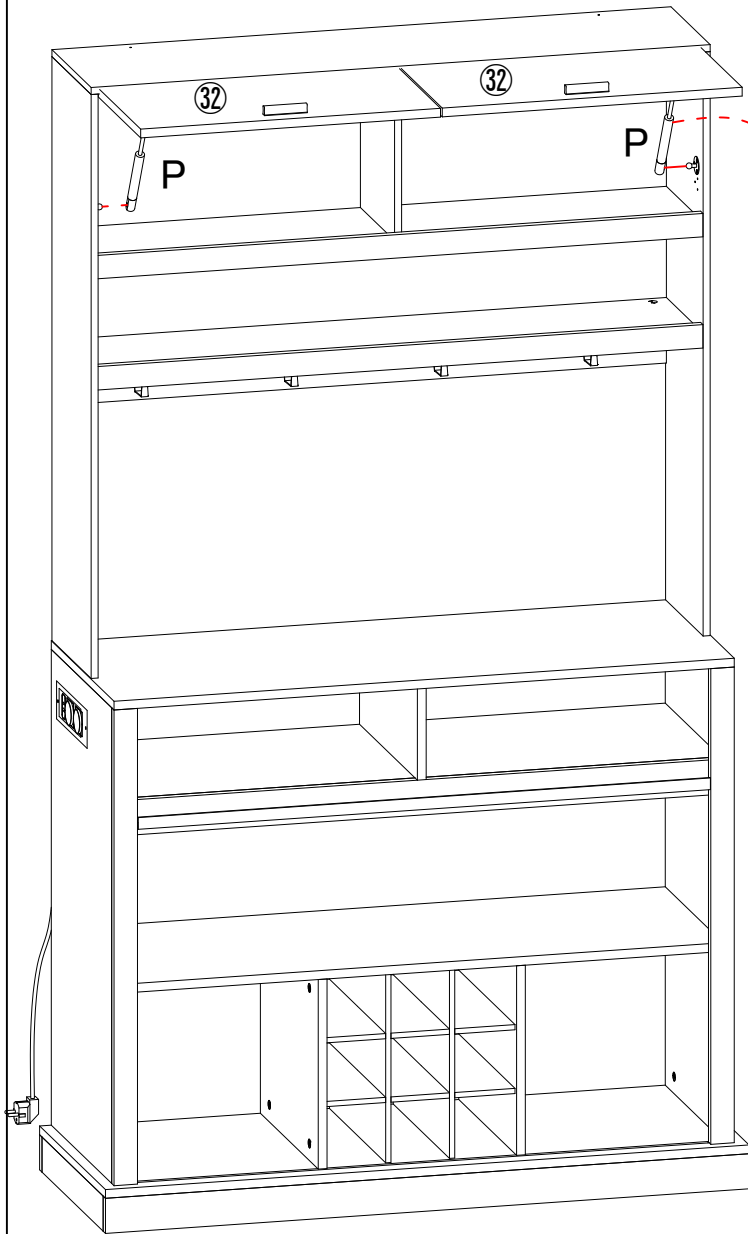

1 Sideways / Tilt adjustment

Turn the screw clockwise to move the door further away from the side of the cabinet
anticlockwise to move the door closer to the side of the cabinet

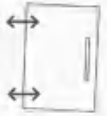

2 4 Height adjustment

While supporting the weight of the door, turn the screws clockwise to move the door up
anticlockwise to move the door down



3 Forward and back adjustment

If the gap between the back of the door and the cabinet is too small, and the door may not close fully. Turn the screw clockwise to decrease the gap between the door and the cabinet
anticlockwise to increase the gap between the door and the cabinet.

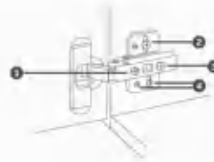

39.

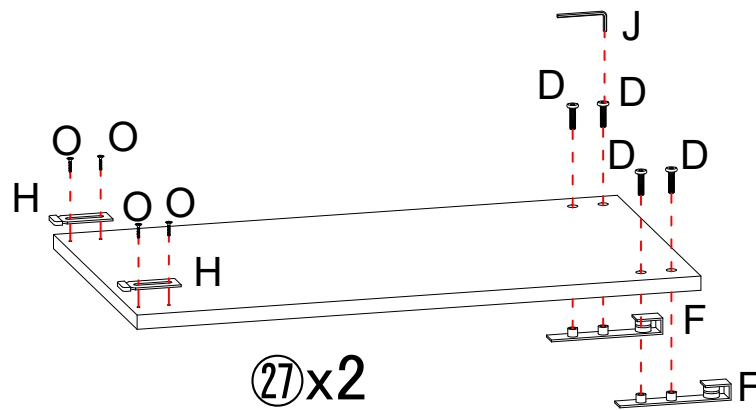

O x8pcs	Dx 8pcs	F x4pcs	H x 4pcs	J x 1pc

40.

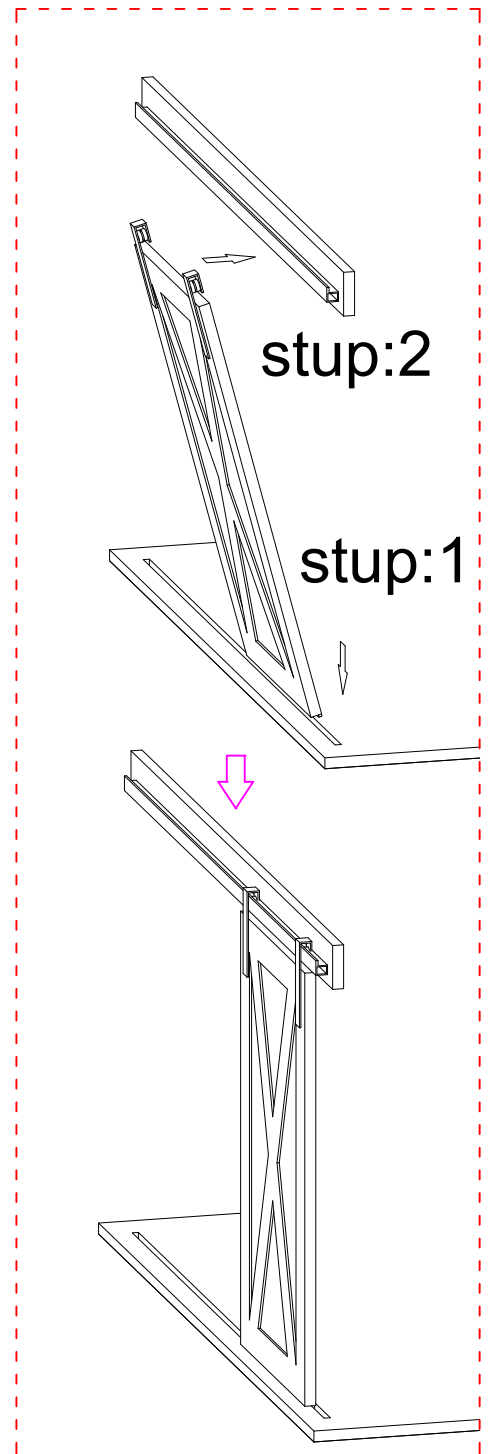
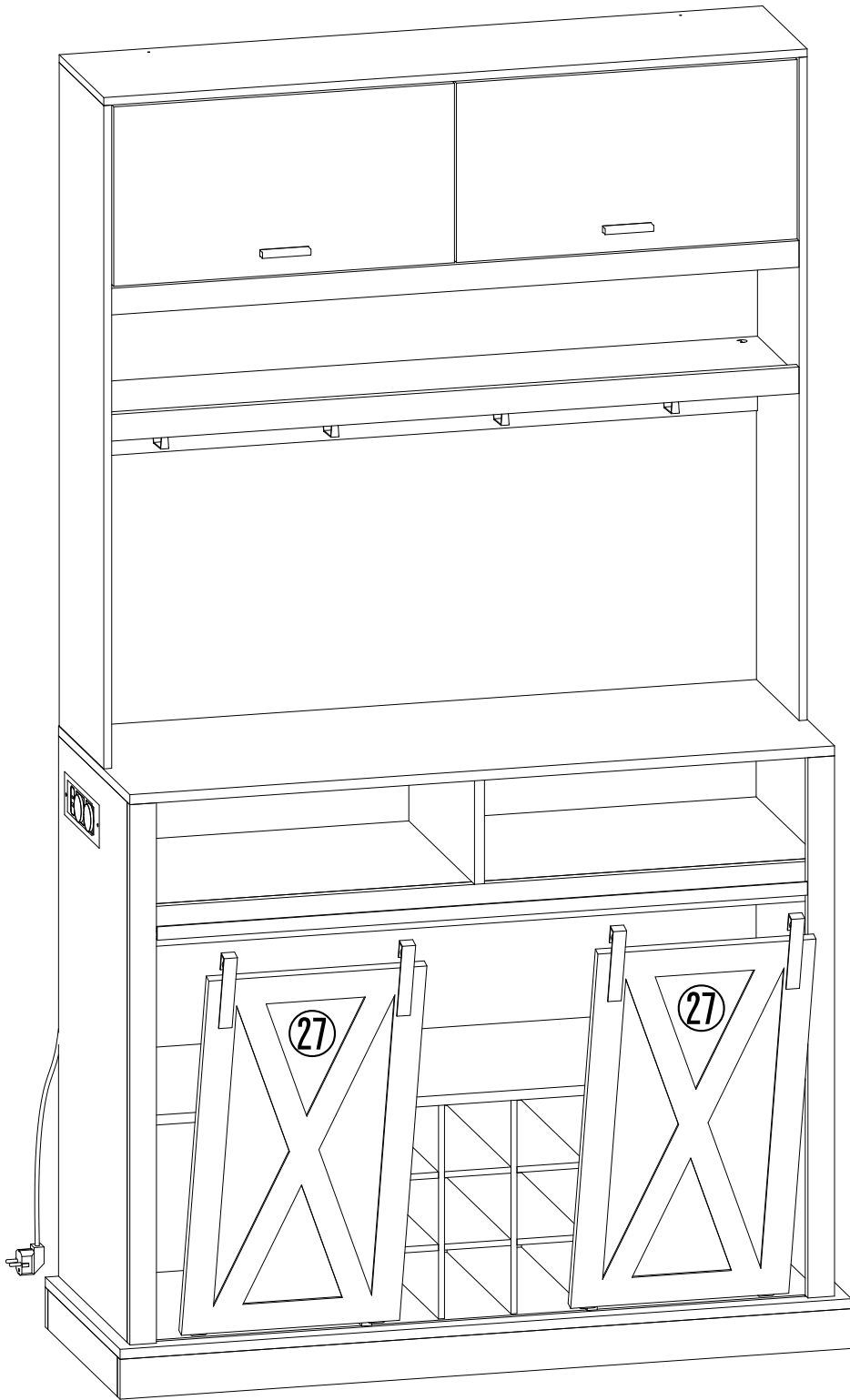

41.



U x 12pcs

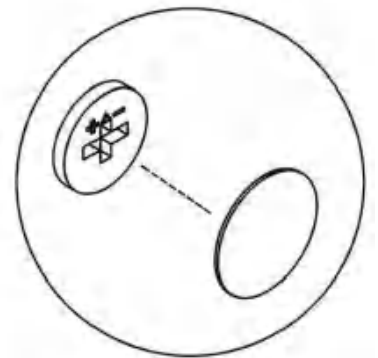
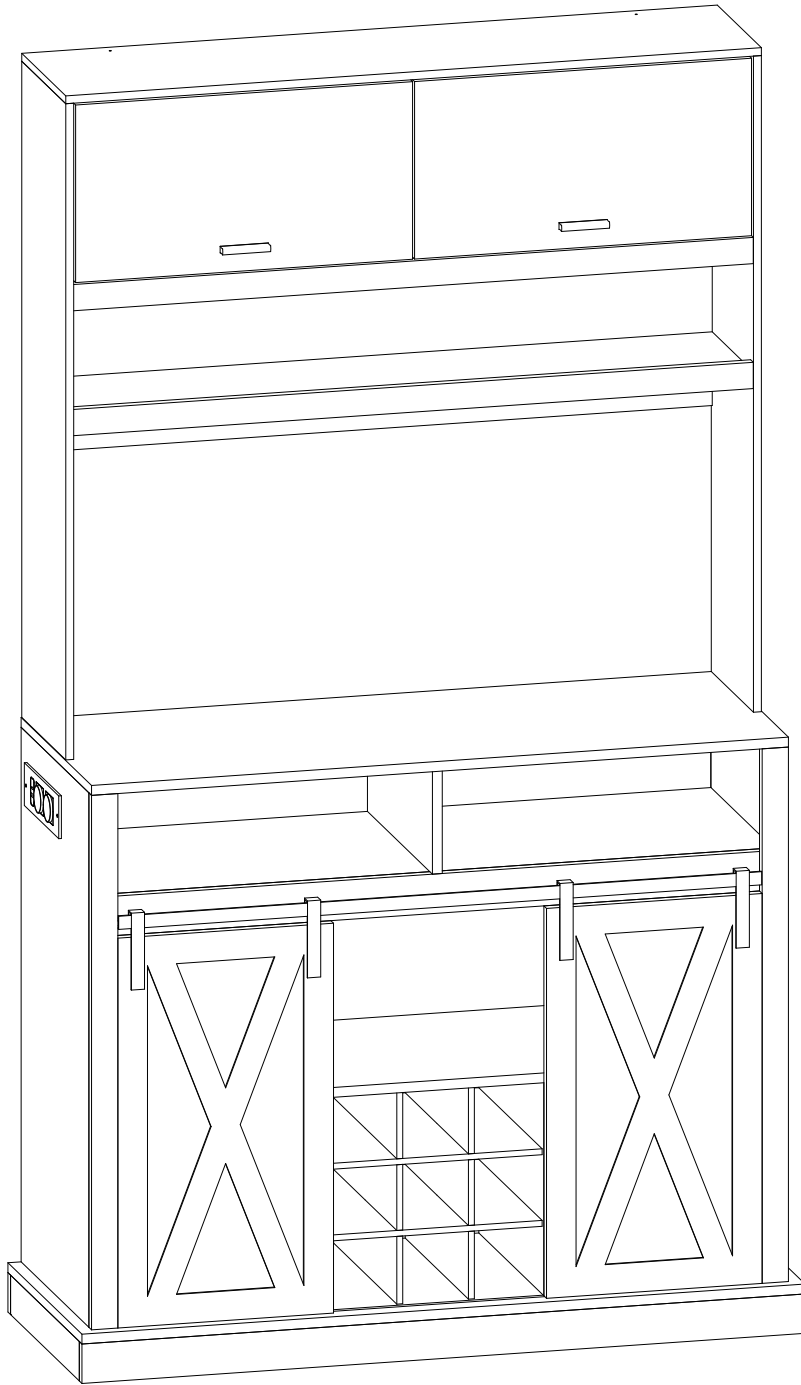

EN:In order to make the product more beautiful,please paste hardware U on the exposed holes.

DE:Um das Produkt noch schöner zu machen, kleben Sie bitte Hardware U auf die freiliegenden Löcher.

FR:Afin de rendre le produit plus beau, s' il vous plaît coller le matériel U sur les trous exposés.

IT:Per rendere il prodotto più bello,incollare l'hardware U sui fori esposti.

ES:Con el fin de hacer el producto más hermoso, por favor pega hardware U en los agujeros expuestos.

Importeur	Decobus Handel GmbH
Adresse	Innungsstraße 9, 21244 Buchholz, Deutschland
URL	https://www.decobusgroup.de
Hersteller	Dongguan Yihong Hardware Electronics Co., Ltd
Adresse	Room 1106, No.2, Shangheng Road, Chang' an Town,Dongguan
URL/Email	yy.67786@163.com
Productiondatum	2026/04
Hergestellt In	China
	Decobus Handel GmbH Innungsstraße 9, 21244 Buchholz,Deutschland https://www.decobusgroup.de
 	Product: Bluetooth 2.4G remote controller Modell: YH-284 Nennspannung: 5V Nennfrequenz: 50-60HZ Leistung: 2A

Importeur	Decobus Handel GmbH
Adresse	Innungsstraße 9, 21244 Buchholz, Deutschland
URL	https://www.decobusgroup.de
Hersteller	Dongguan Xinyi Technology co., LTD
Adresse	5F, Building 2, No.492, Jienanroad, Humen, Dongguan,Guangdong. China
URL/Email	yy.67786@163.com
Productiondatum	2026/04
Hergestellt In	China
	Decobus Handel GmbH Innungsstraße 9, 21244 Buchholz,Deutschland https://www.decobusgroup.de
 	Product: LED light strip Modell: 5050-60D-RGB-10MM-5V Nennspannung: 5V Nennfrequenz: 50-60HZ Leistung: 2A



Registration No. : WTF25F05113956
Reference No. : WTF25F05113956E
Applicant : Dongguan Xinyi Technology co., LTD
Address : 5F, Building 2, No.492, Jienanroad, Humen, Dongguan, Guangdong, China
Manufacturer : The same as above
Address : The same as above
Product : LED strip light
Model No. : Refer to the attached model list
Technical data : Refer to the attached model list

Test specification:

EN IEC 55015:2019+A11:2020
EN IEC 61547:2023

The above product has been tested by us with the listed standards and found in compliance with the European Electromagnetic Compatibility Directive 2014/30/EU. It is possible to use CE marking to demonstrate the compliance with this EMC Directive.

EN IEC 55015: Limits and methods of measurement of radio Disturbance characteristics of electrical lighting and similar equipment.
EN IEC 61547: Equipment for general lighting purposes — EMC immunity requirements

The referred test report(s) show that the product complies with standard(s) recognized as giving presumption of compliance with the essential requirements in the above mentioned EU Directive. Other relevant Directives have to be observed.

After preparation of the necessary technical documentation as well as the conformity declaration, the CE marking as shown below can be affixed on the equipment.



The statement is based on a single evaluation of the sample of above mentioned product. It does not imply an assessment of the whole production.

Waltek Testing Group (Foshan) Co., Ltd.
Hotline: 400-840-2288
Http://www.waltek.com.cn
E-mail: info@waltek.com.cn

WTF0124, WALTEK is registered trademark. Utilization and application requires prior approval.

Attachment

Model list

Reference No.: WTF25F05113956E

Item	Model	Rating	Light Source
1	XYDA-2835-60D		
2	XYDA-2835-120D		
3	XYDA-2835-144D		
4	XYDA-2835-168D	DC 5V, 8W; DC 12V, 9W; DC 24V, 15W	2835
5	XYDA-2835-180D		
6	XYDA-2835-240D		
7	XYDA-2835-192D		
8	XYDA-5050-RGB		
9	XYDA-5050-60D		
10	XYDA-5050-RGBW	DC 5V, 8W; DC 12V, 9W; DC 24V, 14W	5050
11	XYDA-5050-RGB-IC		
12	XY-COB-3-252D		
13	XY-COB-3-528D		
14	XY-COB-5-252D		
15	XY-COB-5-288D		
16	XY-COB-5-320D		
17	XY-COB-5-420D		
18	XY-COB-5-512D		
19	XY-COB-5-528D		
20	XY-COB-8-252D		
21	XY-COB-8-256D		
22	XY-COB-8-384D		
23	XY-COB-8-480D		
24	XY-COB-8-512D		
25	XY-COB-8-528D	DC 5V, 5W; DC 12V, 8W; DC 24V, 10W	COB

Waltek Testing Group (Foshan) Co., Ltd.
Hotline: 400-840-2288
Http://www.waltek.com.cn
E-mail: info@waltek.com.cn

WTF0124, WALTEK is registered trademark. Utilization and application requires prior approval.



TEST REPORT

Report No. : WTF25F05125576C
 Job No. : FSW2505200803CJ
 Applicant : Dongguan Xinyi Technology co., LTD
 Address : 5F, Building 2, No.492, Jiennan road, Humen, Dongguan, Guangdong, China
 Manufacturer : Dongguan Xinyi Technology co., LTD
 Address : 5F, Building 2, No.492, Jiennan road, Humen, Dongguan, Guangdong, China
 Sample Name : LED strip light
 Sample Model : XYDA-2835-80D
 Reference Model : Refer to next page (s)
 Test Requested : With reference to EU RoHS Directive 2011/65/EU and its amendment Directive EU 2015/863, to determine the Pb, Cd, Hg, Cr*, PBBs, PBDEs, DBP, BBP, DEHP, DIBP content in the submitted sample.
 Test Method : Refer to next page (s)
 Test Conclusion : Pass
 Date of Receipt Sample : 2025-05-20
 Testing Period : 2025-05-20 to 2025-05-24
 Date of Issue : 2025-07-08
 Test Result : Refer to next page (s)

Prepared By: **Waltek Testing Group (Foshan) Co., Ltd.**
 Address: No.13-19, 2/F., 2nd Building, Sunlink Machinery City, Xingye 4 Road, Guanglong Industrial Park, Chihua Neighborhood Committee, Chencun, Shunde District, Foshan, Guangdong, China
 Tel:+86-757-23811398 Fax:+86-757-23811381 E-mail:info@waltek.com.cn



Signed for and on behalf of
 Waltek Testing Group (Foshan) Co., Ltd.



Swing Liang
 Waltek Testing Group (Foshan) Co., Ltd.
 http://www.waltek.com.cn



Report No.: WTF25F05125576C Job No.: FSW2505200803CJ

Reference Model

XYDA-2835-120D, XYDA-2835-144D, XYDA-2835-168D, XYDA-2835-180D, XYDA-2835-240D,
 XYDA-2835-192D, XYDA-5050-RGB, XYDA-5050-60D, XYDA-5050-RGBW, XYDA-5050-RGB-IC,
 XY-COB-3-252D, XY-COB-3-528D, XY-COB-5-252D, XY-COB-5-288D, XY-COB-5-320D, XY-COB-5-420D,
 XY-COB-5-512D, XY-COB-5-528D, XY-COB-8-252D, XY-COB-8-256D, XY-COB-8-384D, XY-COB-8-480D,
 XY-COB-8-512D, XY-COB-8-528D, XY-COB-RGB-10-576D, XY-COB-RGB-10-768D, XY-COB-RGB-10-784D,
 XY-COB-RGB-10-784D

Sample photo:





Attestation of Compliance

Attestation No. : LCS220317036AE
Approval Holder : Dongguan Yihong Hardware Electronics Co., Ltd
Address : Room 1106, No.2, Shangheng Road, Chang' an Town, Dongguan
Manufacturer : Dongguan Yihong Hardware Electronics Co., Ltd
Address : Room 1106, No.2, Shangheng Road, Chang' an Town, Dongguan
Brand Name : YH
Product : Bluetooth 2.4G remote controller
Type/Model Name : YH-284, YH-290, YH-287, YH-358, YH-360
H/S Version : HW: /
SW: /

Attestation of the technical design of the radio equipment according to the following essential requirements set out in article 3 of the RED 2014/53/EU:

Article 3.1a): Health and Safety	Conform
Article 3.1b): Electromagnetic Compatibility	Conform
Article 3.2: Effective Use of the Radio Spectrum	Conform

CE-marking



Marking Example (Class 1)



This attestation is issued in accordance with the Directive 2014/53/EU of the European Parliament and of the Council of 16 April 2014 on the harmonisation of the laws of the Member States relating to the making available on the market of radio equipment.

April 28, 2022

Date of issue



Shenzhen LCS Compliance Testing Laboratory Ltd.
Room 101, 201, Building A and Room 301, Building C, Juji Industrial Park, Yabianzhuwei, Shajing Street, Bao'an District,
Shenzhen, Guangdong, China
Tel: (86)755-82591330
Fax: (86)755-82591332
Http://www.LCS-cert.com
Email: webmaster@LCS-cert.com

Importeur	Decobus Handel GmbH
Adresse	Innungsstraße 9, 21244 Buchholz, Deutschland
URL	https://www.decobusgroup.de
Hersteller	DONGGUAN BAIYOU ELECTRONIC CO.,LTD
Adresse	2F A Building WuFeng Industrial Park 21st JinTan Road ShanWu ShiJie Town DongGuan City GuangDong
URL/Email	dgbaiyou@163.com
Produktionsdatum	2026/04
Hergestellt In	China
	Decobus Handel GmbH Innungsstraße 9, 21244 Buchholz, Deutschland https://www.decobusgroup.de
 	Product: Furniture socket Modell: BAYU-AE02AC0524 Nennspannung: 16A Nennfrequenz: 230V Leistung: 3680W

Test Verification of Conformity

Verification Number: 250805098GZU-VOC001

On the basis of the tests undertaken, the sample(s) of the below product has been tested by an accredited 3rd party laboratory in accordance to the referenced specification(s)/standards(s) at the time the tests were carried out. This verification is part of the full test report(s) and should be read in conjunction with it them(s).

This document can be used in support of a claim in meeting relevant EU legislation and mandatory Conformity Marking. And in accordance with EU law, the claim is the sole obligation of the Manufacturer/ Importer.

Applicant Name & Address:	Dongguan baiyou electronic Co., Ltd 2 F A building wufeng industrial jintanroad shijie town DONGGUAN Guangdong, China
Product Description:	Multiple socket outlets
Ratings & Principle Characteristics:	See appendix
Models/Type References:	See appendix
Brand Names:	BAYU
Specification(s)/Standards:	SS 428 08 34: 2013+T1:2018 Low Voltage Directive 2014/35/EU
Verification Issuing Office Name & Address:	Intertek Testing Services Shenzhen Ltd, Guangzhou Branch Room101/301/401/102/202/302/402/502/602/702/802, No. 7-2, Caipin Road, Huangpu District, Guangzhou, Guangdong, China
Date of Tests:	2025-08-05 to 2025-12-16
Test Report Number(s):	250805098GZU-001: 2026-01-04 250805098GZU-002: 2026-01-04

Hunter Chu

Signature

Name: Hunter Chu
Position: Manager
Date: Jan. 12, 2026

This verification is for the exclusive use of Intertek's clients and is provided pursuant to the agreement between Intertek and its Client. Intertek's responsibility and liability are limited to the terms and conditions of the agreement. Intertek does not verify any data, other than to the extent of its assistance with the agreement. Any data, document or sample submitted by the client of this verification. Only the Client is authorized to permit copying or distribution of this verification. Any use of the Intertek name or one of its marks for the sale or advertisement of the actual material, product or service must first be approved in writing by Intertek. This observation and test/reporting results referenced in this verification are always only to the sample tested/inspected. This verification is valid provided that the physical product, or service is of the same type as the Intertek certificate/verification.

APPENDIX: Test Verification of Conformity

This is an Appendix to Test Verification of Conformity Number: 250805098GZU-VOC001

Models/Type References:

BAYU-****-**
The first ** may be AE, AEF, AER.
The second ** may be 01, 02, 03, 04, 05, 06.
The third ** may be AA, AC, ACC.
The fourth ** may be 0524, 1215.
The fifth ** may be K or blank.
The sixth ** may be AC, DC, USB.
250V~, 50Hz, 16A, Max. 3680W@230V~
For Type A+A USB charger:
USB A1/A2: 5VDC2.4A
Total output: 5VDC2.4A.
For Type A+C USB charger:
1): USB-C: 5VDC2.4A
USB-A: 5VDC2.4A
Total output: 5VDC2.4A.
2): USB-C: 5VDC3A, 9VDC2.22A, 12VDC1.67A
USB-A: 5VDC3A, 9VDC2A, 12VDC1.5A
USB-A+USB-C: 5VDC 3A Max
3): USB-C: 5VDC3A, 9VDC2.22A, 12VDC1.67A
USB-A: 5VDC3A
USB-A+USB-C: 5VDC 3A Max
For Type A+C+USB charger:
1): USB-C1/C2: 5VDC2.4A
USB-A: 5VDC2.4A
Total output: 5VDC2.4A
2): USB-C1/C2: 5VDC3A, 9VDC2.22A, 12VDC1.67A
USB-A: 5VDC3A, 9VDC2A, 12VDC1.5A
USB-A+USB-C1+USB-C2: 5VDC 3A Max

Ratings & Principle Characteristics:

Hunter Chu

Signature

Name: Hunter Chu
Position: Manager
Date: Jan. 12, 2026

This verification is for the exclusive use of Intertek's clients and is provided pursuant to the agreement between Intertek and its Client. Intertek's responsibility and liability are limited to the terms and conditions of the agreement. Intertek does not verify any data, other than to the extent of its assistance with the agreement. Any data, document or sample submitted by the client of this verification. Only the Client is authorized to permit copying or distribution of this verification. Any use of the Intertek name or one of its marks for the sale or advertisement of the actual material, product or service must first be approved in writing by Intertek. This observation and test/reporting results referenced in this verification are always only to the sample tested/inspected. This verification is valid provided that the physical product, or service is of the same type as the Intertek certificate/verification.

Test Verification of Conformity

Verification Number: 250811262GZU-VOC001

On the basis of the tests undertaken, the sample(s) of the below product has been tested by an accredited 3rd party laboratory in accordance to the referenced specification(s)/standard(s) at the time the tests were carried out. This verification is part of the full test report(s) and should be read in conjunction with it (them).

This document can be used in support of a claim in meeting relevant 2014/30/EU legislation and mandatory Conformity Marking. And in accordance with EU law, the claim is the sole obligation of the Manufacturer/ Importer.

<p>Applicant Name & Address: Dongguan baiyou electronic Co., Ltd 2 F A Building wufeng industrial jintanroad shijie town DONGGUAN Guangdong, China</p> <p>Product Description: Multiple socket-outlets 250V~, 50Hz, 16A, Max. 3680W@230V~</p> <p>Ratings & Principal Characteristics: For Type A+A USB charger: USB A1/A2: 5VDC2.4A, Total output: 5VDC2.4A. For Type A+C USB charger: 1]-USB-C: 5VDC2.4A, USB-A: 5VDC2.4A, Total output: 5VDC2.4A. 2]-USB-C: 5VDC3A, 9VDC2.22A, 12VDC1.67A, USB-A: 5VDC3A, 9VDC2A, 12VDC1.5A USB-A+USB-C: 5VDC 3A Max 3]-USB-C: 5VDC3A, 9VDC2.22A, 12VDC1.67A, USB-A: 5VDC3A, USB-A+USB-C: 5VDC 3A Max For Type A+4G+C USB charger: 1]-USB-C1/C2: 5VDC2.4A, USB-A: 5VDC2.4A, Total output: 5VDC2.4A 2]-USB-C1/C2: 5VDC3A, 9VDC2.22A, 12VDC1.67A, USB-A: 5VDC3A, 9VDC2A, 12VDC1.5A USB-A+USB-C1+USB-C2: 5VDC 3A Max. see Appendix</p> <p>Models/Type References: —</p> <p>Brand Names: EN IEC 61000-6-3:2021 EN IEC 61000-6-1:2019</p> <p>Specifications<->Standards: Intertek Testing Services Shenzhen Ltd, Guangzhou Branch Room101/301/401/102/202/302/402/502/602/702/802, No. 7-2, Caipin Road, Huangpu District, Guangzhou, Guangdong, China</p> <p>Address: 08 September 2025-15 September 2025 250811262GZU-001</p> <p>Date of Tests: Test Report Number(s): Additional information in Appendix.</p>	<p>Signature</p> <p>Name: Dean Liu Position: Sr. Project Engineer Date: 13 January 2026</p>
---	---

This verification is for information only and does not constitute a warranty. The manufacturer is responsible for ensuring that the product complies with the relevant standards and regulations. The user of the product should read the manufacturer's instructions and safety warnings. Intertek is not responsible for any damage or loss resulting from the use of the product. This document is the property of Intertek and should be kept confidential. The information and data provided in this document is for the sole use of the client and should not be used for any other purpose without the prior written consent of Intertek.

APPENDIX: Test Verification of Conformity

This is an Appendix to Test Verification of Conformity Number: 250811262GZU-VOC001

Models/Type References:

- BAYU-****, **
- "BAYU" represents the company name.
- The subsequent fields indicate product features in the following order:
 - AE: Regular long strip shape.
 - AER: Regular long strip shape with built-in USB charger assembly in the middle.
 - The second "*" indicates the number of socket-outlets. Options include: 01, 02, 03, 04, 05, 06.
 - The third "*" specifies the type of USB charger module, it can be blank or following features:
 - AA: A + A USB ports.
 - AC: A + C USB ports.
 - ACC: A + C + C USB ports.
 - The fourth "*" defines the USB charging output specification, it can be blank or following features:
 - 0524: Maximum output 5V DC / 2.4A.
 - 1215: Maximum output 12V DC / 1.5A.
 - The fifth "*" indicates whether the product is equipped with CBE functionality. Currently, the options are K or blank.
 - The sixth "*" refers to additional output features: It can be blank or following features:(The same as the USB module. On the PCB board, solder the USB and DC lines at the A port pin location):
 - AC: Equipped with a single non-rewirable socket outlet (250V~, 2.5A).
 - DC: Equipped with a single DC port output (5VDC,2.4A).
 - USB: Equipped with a single USB port output (5V DC, 2.4A).

Dean Liu

Signature

Name: Dean Liu
Position: Sr. Project Engineer
Date: 13 January 2026

This verification is for information only and does not constitute a warranty. The manufacturer is responsible for ensuring that the product complies with the relevant standards and regulations. The user of the product should read the manufacturer's instructions and safety warnings. Intertek is not responsible for any damage or loss resulting from the use of the product. This document is the property of Intertek and should be kept confidential. The information and data provided in this document is for the sole use of the client and should not be used for any other purpose without the prior written consent of Intertek.

