

N657P282997

N657P282998

Product manual
Gebrauchsanweisung
Manuel du produit
Manual del producto
Manuale del prodotto

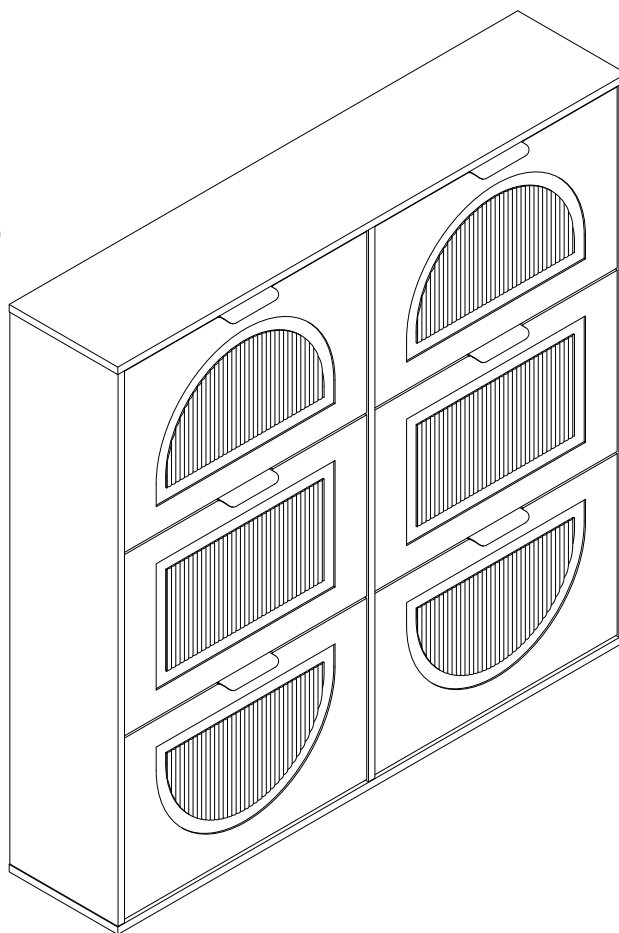

EN:Our product will be delivered to you in 2 packages.
The delivery times of these 2 packages may differ, please
be patient and thank you for your understanding

FR:Notre produit vous sera livré en 2 colis. Les délais de
livraison de ces 2 colis peuvent différer, soyez
patient et merci de votre compréhension.

DE:Unser Produkt wird Ihnen in 2 Paketen geliefert. Die
Lieferzeiten dieser 2 Pakete können abweichen, bitte haben
Sie etwas Geduld und vielen Dank für Ihr Verständnis

IT:I nostri prodotti vengono trasportati in due pacchetti. I
tempi di consegna dei due pacchetti sono diversi:

abbiate pazienza e vi ringrazio per la vostra comprensione.

ES:Nuestro producto se entrega en dos paquetes. El
tiempo de entrega de estos dos paquetes es diferente. Por
favor, sea paciente. Gracias por su comprensión.

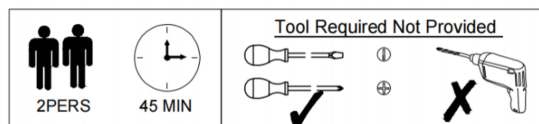

Importeur	Decobus Handel GmbH
Adresse	Innungsstraße 9, 21244 Buchholz, Deutschland
URL	https://www.decobusgroup.de
Hersteller	Chengdu Shuhongyang Furniture Co., Ltd
Adresse	379 North Street, Sanyang Community, Shi Yang Town, Dujiangyan City, Chengdu City, Sichuan Province, China
Email/URL	wxq18280176339@163.com

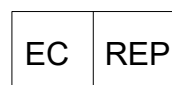

Decobus Handel GmbH

Innungsstraße 9, 21244 Buchholz, Deutschland

<https://www.decobusgroup.de>

English

IMPORTANT ! KEEP FOR FUTURE REFERENCE : READ CAREFULLY

- To be assembled by an adult. Assembly must be checked by an adult before use.
- WARNING ! Keep all screws, small parts and plastic bags out of the reach of children.
- Properly identify all parts before assembling.
- Anchor unit to stud or wall.
- Always use on a level, even surface.
- Avoid the risk of fire by not placing furniture near sources of ignition or hot items.
- DO NOT place hot or cold items directly onto the surface.
- DO NOT place the item next to a radiator or direct sunlight.
- DO NOT allow children to climb on unit.
- DO NOT put the product in a humid environment.

Deutsch

WICHTIG ! ZUM SPÄTEREN NACHSCHLAGEN AUFBEWAHREN: SORGFÄLTIG LESEN

- Muss von einem Erwachsenen zusammengebaut werden. Der Zusammenbau muss vor der Benutzung von einem Erwachsenen überprüft werden.
- WARNUNG! Bewahren Sie alle Schrauben, Kleinteile und Plastikbeutel außerhalb der Reichweite von Kindern auf.
- Kennzeichnen Sie vor dem Zusammenbau alle Teile ordnungsgemäß.
- Verankern Sie das Gerät an einem Ständer oder einer Wand.
- Benutzen Sie das Gerät immer auf einer ebenen, geraden Fläche.
- Vermeiden Sie das Risiko eines Brandes, indem Sie die Möbel nicht in der Nähe von Zündquellen oder heißen Gegenständen aufstellen.
- Stellen Sie KEINE heißen oder kalten Gegenstände direkt auf die Oberfläche.
- Stellen Sie das Gerät NICHT in der Nähe eines Heizkörpers oder direkter Sonneneinstrahlung auf.
- Erlauben Sie Kindern NICHT, auf das Gerät zu klettern.
- Stellen Sie das Gerät NICHT in einer feuchten Umgebung auf.

Français

IMPORTANT ! CONSERVER POUR RÉFÉRENCE ULTÉRIEURE : LIRE ATTENTIVEMENT

- A assembler par un adulte. Le montage doit être vérifié par un adulte avant utilisation.
- ATTENTION ! Conservez toutes les vis, les petites pièces et les sacs en plastique hors de portée des enfants.
- Identifiez correctement toutes les pièces avant de les assembler.
- Fixer l'appareil à un montant ou à un mur.
- Utilisez toujours l'appareil sur une surface plane et uniforme.
- Évitez les risques d'incendie en ne plaçant pas les meubles à proximité de sources d'inflammation ou d'objets chauds.
- NE PAS placer d'objets chauds ou froids directement sur la surface.
- NE PAS placer l'appareil à côté d'un radiateur ou de la lumière directe du soleil.
- NE PAS laisser les enfants grimper sur l'appareil.
- NE PAS placer le produit dans un environnement humide.

Italiano

IMPORTANTE! CONSERVARE PER RIFERIMENTO FUTURO: LEGGERE ATTENTAMENTE

- Deve essere assemblato da un adulto. L'assemblaggio deve essere controllato da un adulto prima dell'uso.
- **AVVERTENZA !** Tenere tutte le viti, le piccole parti e i sacchetti di plastica fuori dalla portata dei bambini.
- Identificare correttamente tutte le parti prima dell'assemblaggio.
- Ancorare l'unità a un pilastro o a una parete.
- Utilizzare sempre su una superficie piana e uniforme.
- Evitare il rischio di incendio non collocando i mobili vicino a fonti di accensione o ad oggetti caldi.
- **NON** collocare oggetti caldi o freddi direttamente sulla superficie.
- **NON** collocare l'apparecchio vicino a un termosifone o alla luce diretta del sole.
- **NON** permettere ai bambini di arrampicarsi sull'unità.
- **NON** collocare il prodotto in un ambiente umido.

Español

¡ IMPORTANTE ! CONSERVELO PARA FUTURAS CONSULTAS: LEA ATENTAMENTE

- Debe montarlo un adulto. El montaje debe ser comprobado por un adulto antes del uso.
- **ADVERTENCIA** Mantenga todos los tornillos, piezas pequeñas y bolsas de plástico fuera del alcance de los niños.
- Identifique correctamente todas las piezas antes del montaje.
- Ancle la unidad a un montante o pared.
- Utilí celo siempre sobre una superficie plana y nivelada.
- Evite el riesgo de incendio no colocando los muebles cerca de fuentes de ignición o artículos calientes.
- **NO** coloque objetos calientes o fríos directamente sobre la superficie.
- **NO** coloque el mueble cerca de un radiador o de la luz solar directa.
- **NO** permita que los niños se suban a la unidad.
- **NO** coloque el producto en un ambiente húmedo.

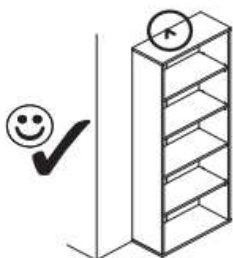

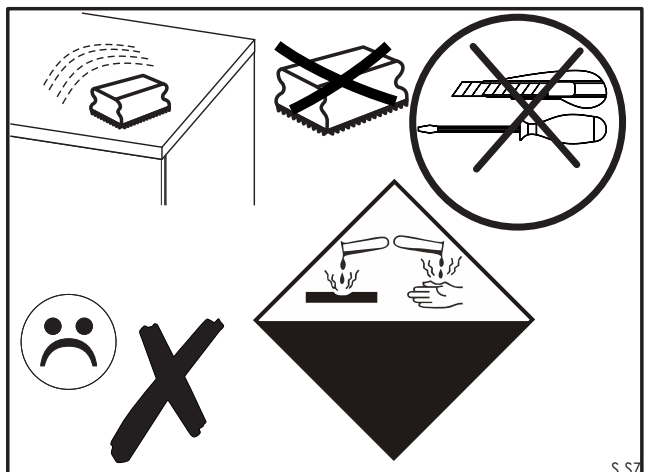
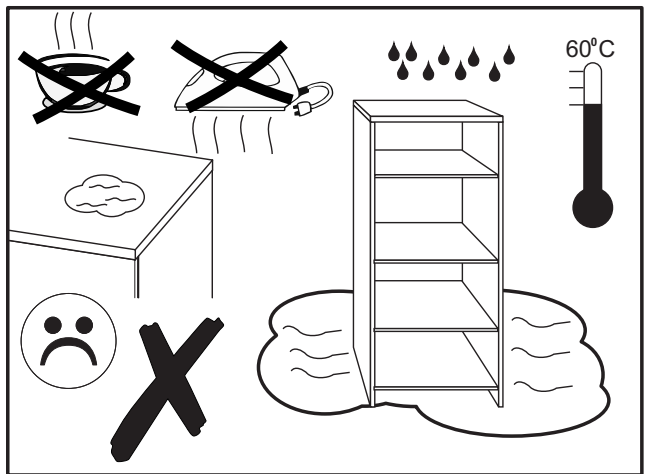
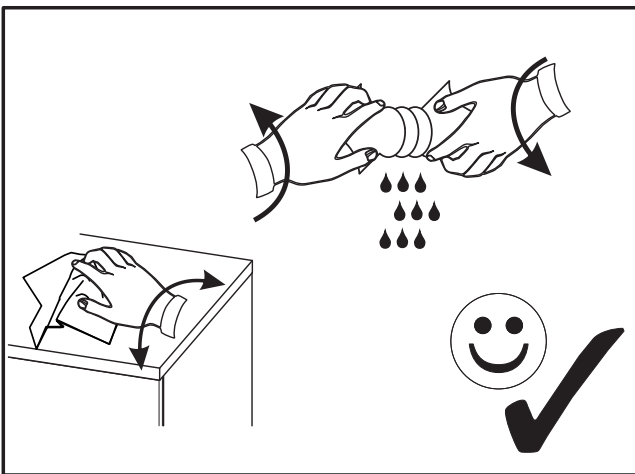
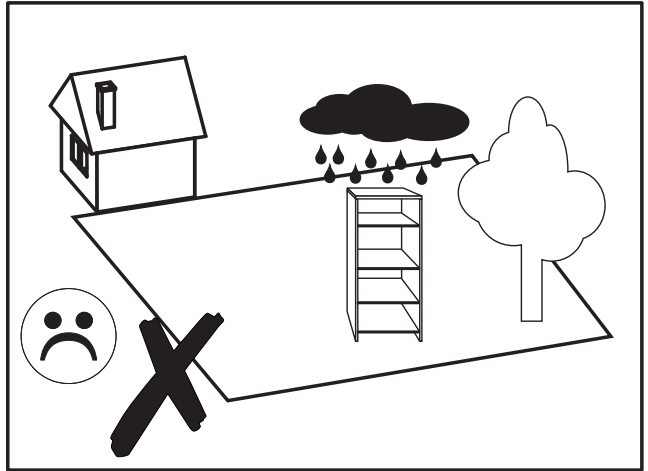
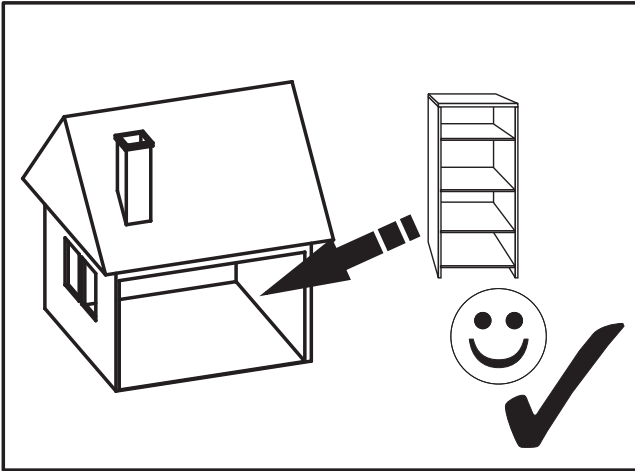

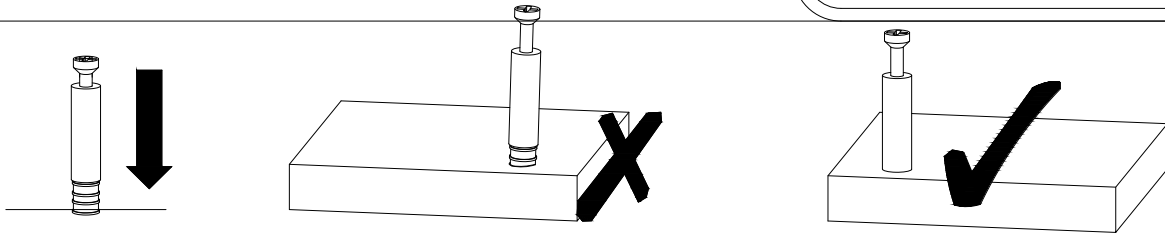

EN_Q4ICKFIT:Tighten quickfit until shoulder is flush with panel.Do not overtighten or undertighten
 FR_RACCORD RAPIDE:Faites serrer le raccord rapide jusqu'à ce que l'épaulement soit parfaitement encastré dans le panneau. Il ne faut ni trop serrer ni insuffisamment serrer.
 ES_QUICKFIT:Apriete quickfit hasta que el hombro se descargue con el panel. NO lo sobreapriete nilo apriete poco.
 PT_AJUSTE RAPIDO: Aperte o ajuste rápido até estar nivelada com o painel. Não apertar demasiado ou excessivamente.
 DE_QUICKFIT:Ziehen Sie den Quickfit fest, bis die Schulter mit der Platte bundig ist. Bite nicht zu fest oder zu schwach anziehen.
 IT_MONTAGGIO RAPIDO:Stringere il montaggio rapido fino a quando la spalla è a filo con il pannello,non stringere troppo o troppo poco.

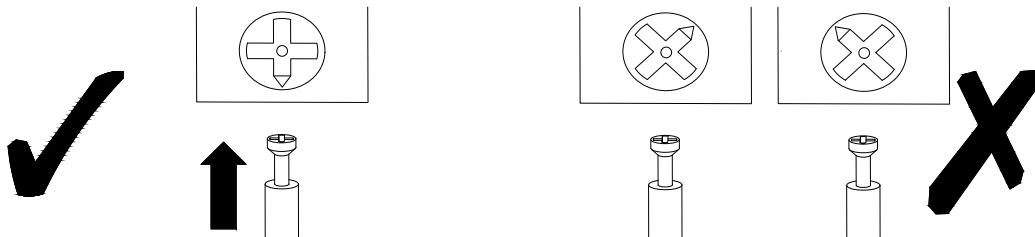

EN_CAM LOCK:When fitting cam lock, ensure starting position is correct before you insert connecting quickfit.

FR_SERRURE BATTEUSE:Avant d'insérer la serrure batteuse, veillez à la bonne orientation avant d'insérer le raccord rapide.

ES_CIERRE DE LA CAMARA:Cuando instale el cierre de la cámara, asegúrese de que la posición de inicio es correcta antes de que inserte el quickfit conector.

PT_BLOQUEIO: Ao instalar o bloqueio, assegurar-se de que a posição inicial está correcta antes de inserir o encaixe de ligação rápida.

DE_CAM-LOCK:Achten Sie bei der Montage des Cam-Locks auf die richtige Ausgangsposition. bevor Sie den Quickfit einsetzen.

IT_BLOCCAGGIO A CAMMA:Quando si monta il bloccaggio a camma, assicurarsi che la posizione iniziale sia corretta prima di inserire il montaggio rapido di collegamento.

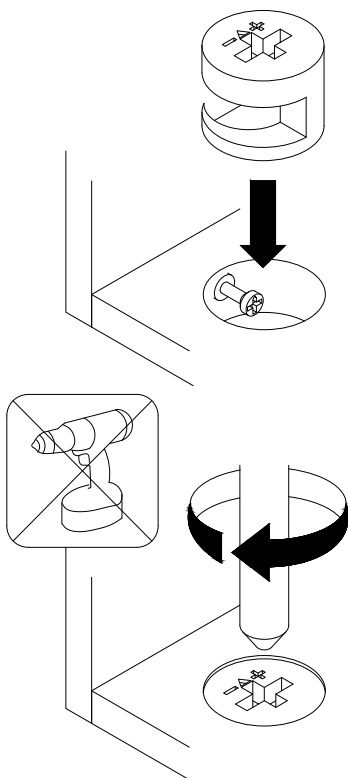

EN_Quickfit head should be in the centre of the cam lock when the two panels are joined.

Camlock should be inserted before quickfit.

FR_Lorsque les deux panneaux sont assemblés, la tête du raccord rapide doit se poser au centre de la serrure batteuse.

Il faut insérer la serrure batteuse avant le raccord rapide.

ES_El cabezal del quickfit debe estar en el centro del cierre de la cámara cuando se unan los dos paneles.

Se debe insertar el cierre de la cámara antes que el quickfit.

PT_A cabeça de ajuste rápido deve estar no centro da fechadura quando os dois painéis estão unidos.

A fechadura de cammas deve ser inserida antes de ser rápida.

DE_Der Quickfit-Kopf sollte sich in der Mitte des Cam-Locks befinden. wenn die beiden Platten zusammengefügt sind.

Der Cam-Lock sollte vor dem Quickfit eingesetzt werden.

IT_La testa del montaggio rapido deve trovarsi al centro del bloccaggio a camma quando i due pannelli sono uniti.

Il Bloccaggio a Camma deve essere inserito prima del montaggio rapido.

EN_Turn cam lock clockwise to tighten.

FR_Faites tourner la serrure batteuse dans le sens des aiguilles d'une montre pour la resserrer.

ES_Gire el cierre de la cámara en sentido horario para apretarlo.

PT_Rodar o bloqueio no sentido dos ponteiros do relógio para o apertar.

DE_Drehen Sie den Cam-Lock im Uhrzeigersinn, um ihn festzuziehen.

IT_Ruotare il bloccaggio a camma in senso orario per stringere.

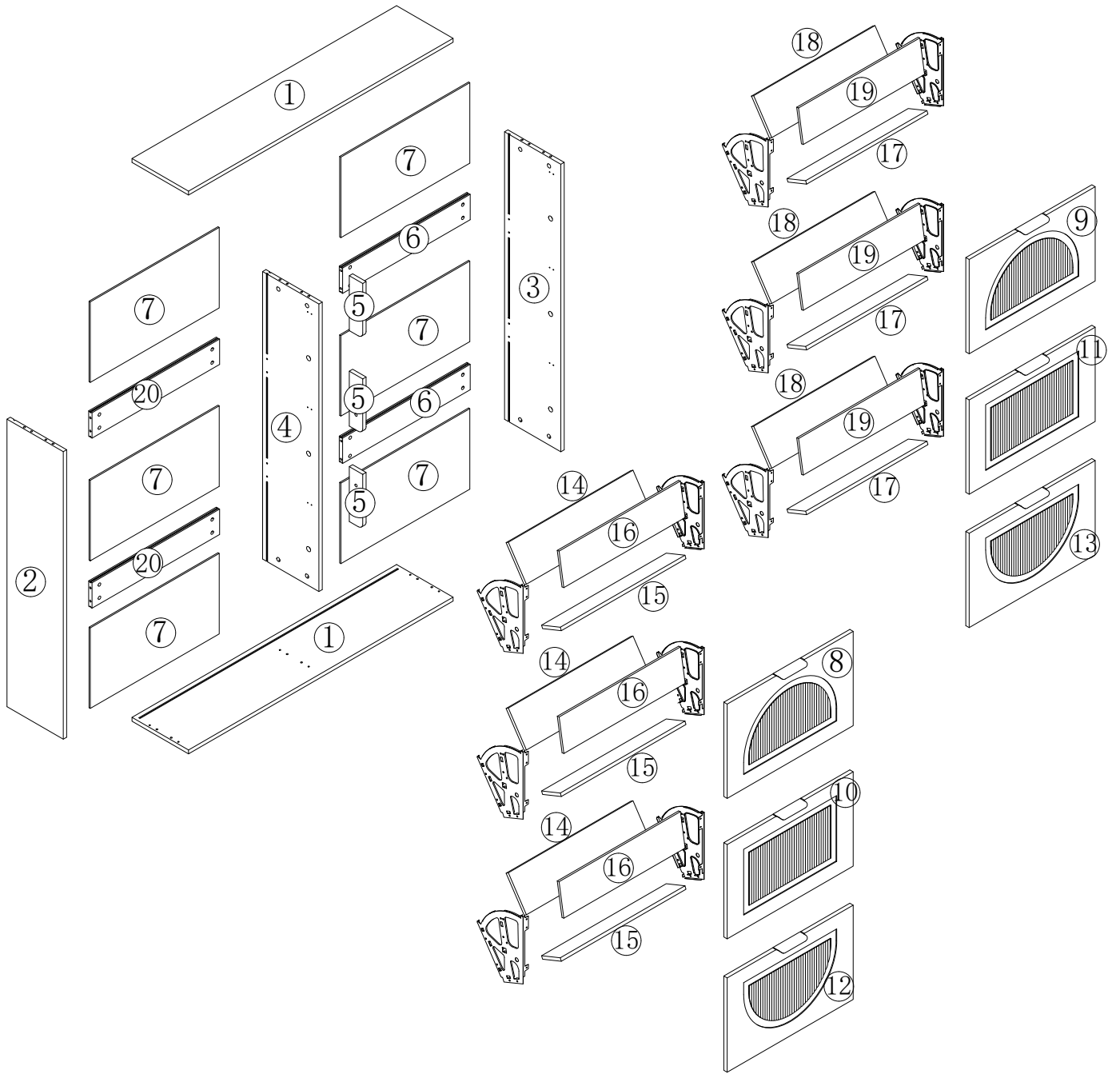

BOX1:N657P282997

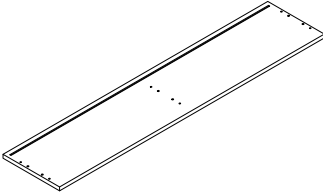
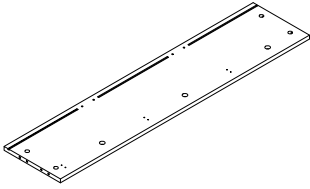
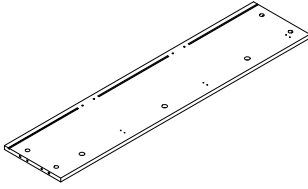
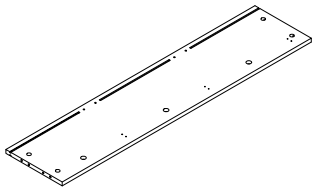
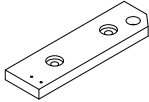
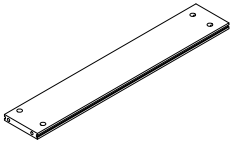
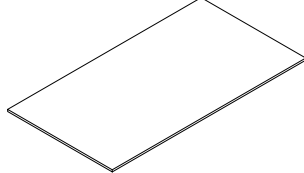
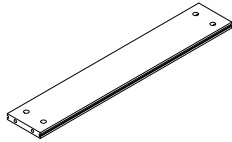
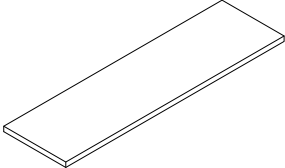
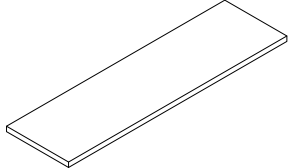

			
① x2pcs	② x1pc	③ x1pc	④ x1pc
			
⑤ x3pcs	⑥ x2pcs	⑦ x6pcs	⑳ x2pcs
			
⑯ x3pcs	⑲ x3pcs		

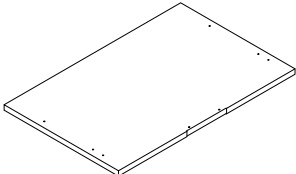
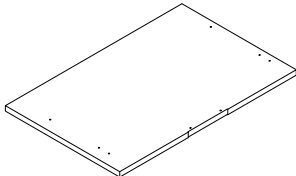
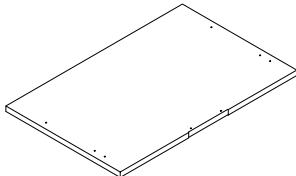
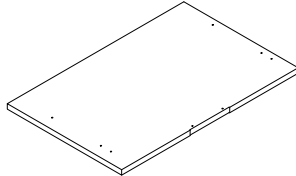
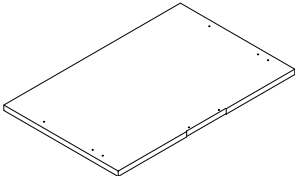
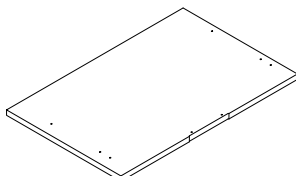
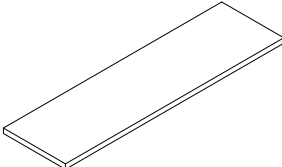
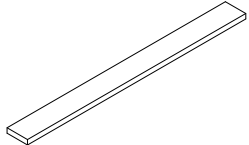
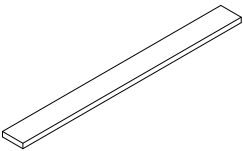
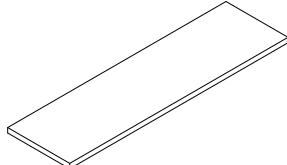
BOX2: N657P282998

			
⑧ x1pc	⑨ x1pc	⑩ x1pc	⑪ x1pc
			
⑫ x1pc	⑬ x1pc	⑭ x3pcs	⑮ x3pcs
			
⑰ x3pcs	⑱ x3pcs		

Hardware liste

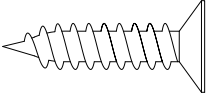
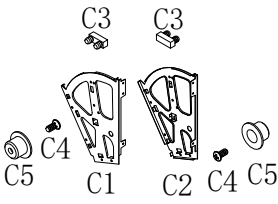
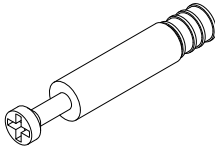
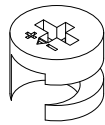
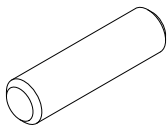
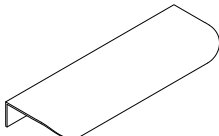
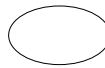
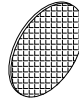
N657P282998

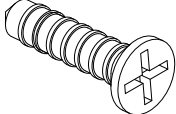
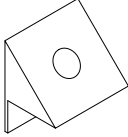
 M3*14mm	 C3 C3 C4 C5 C1 C2 C4 C5	 M6*34mm	 Ø12*10mm	 Ø6*30mm
Ⓐ x110pcs	Ⓒ x6pcs	Ⓓ x28pcs	Ⓔ x28pcs	Ⓕ x12pcs
		 Φ 15*2mm		 M6*22
Ⓖ x6pcs	Ⓗ x28pcs	Ⓘ x6pcs	Ⓙ x1pc	Ⓝ x6pcs
				
Ⓟ x24pcs				

Hardware list N657P282998

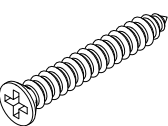
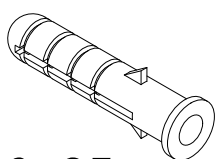
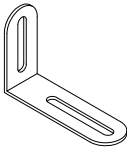
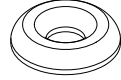
 M4*30mm	 Ø6*25mm		
Ⓑ x2pcs	Ⓚ x2pcs	Ⓛ x2pcs	Ⓠ x4pcs

Note: Metal hooks are a bonus gift. Installation position could be adjusted according to your own preference.

1

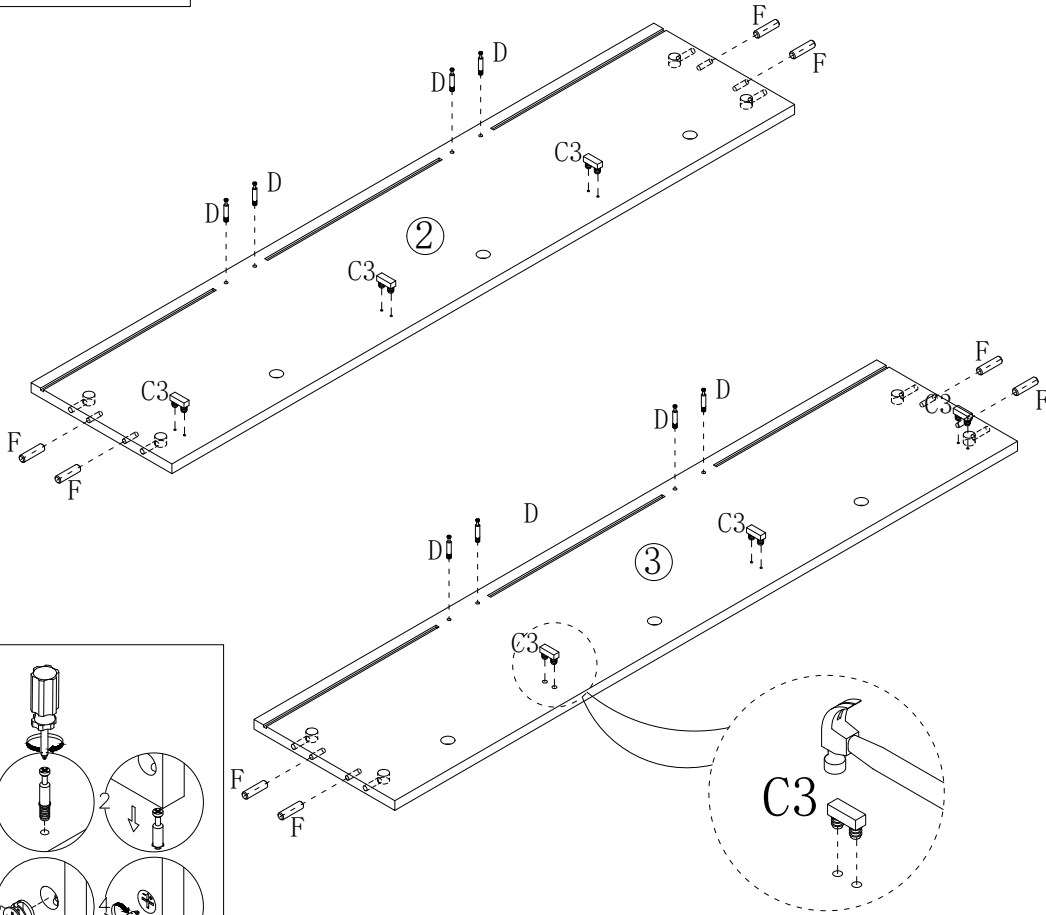

ø6*30mm	M6*34mm
ⓕ x8pcs	ⓓ x8pcs

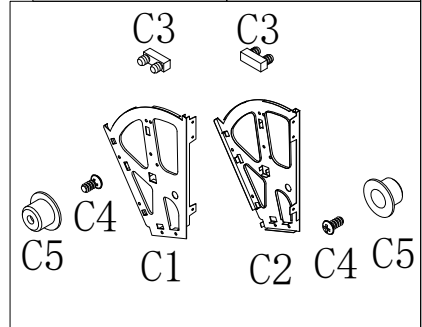

ⓐ x3pcs

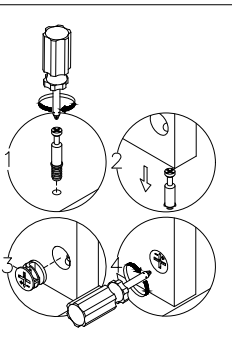
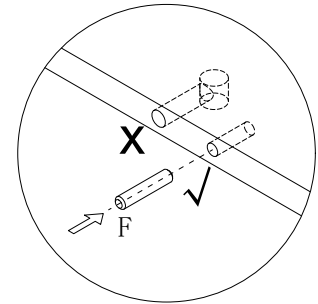

2

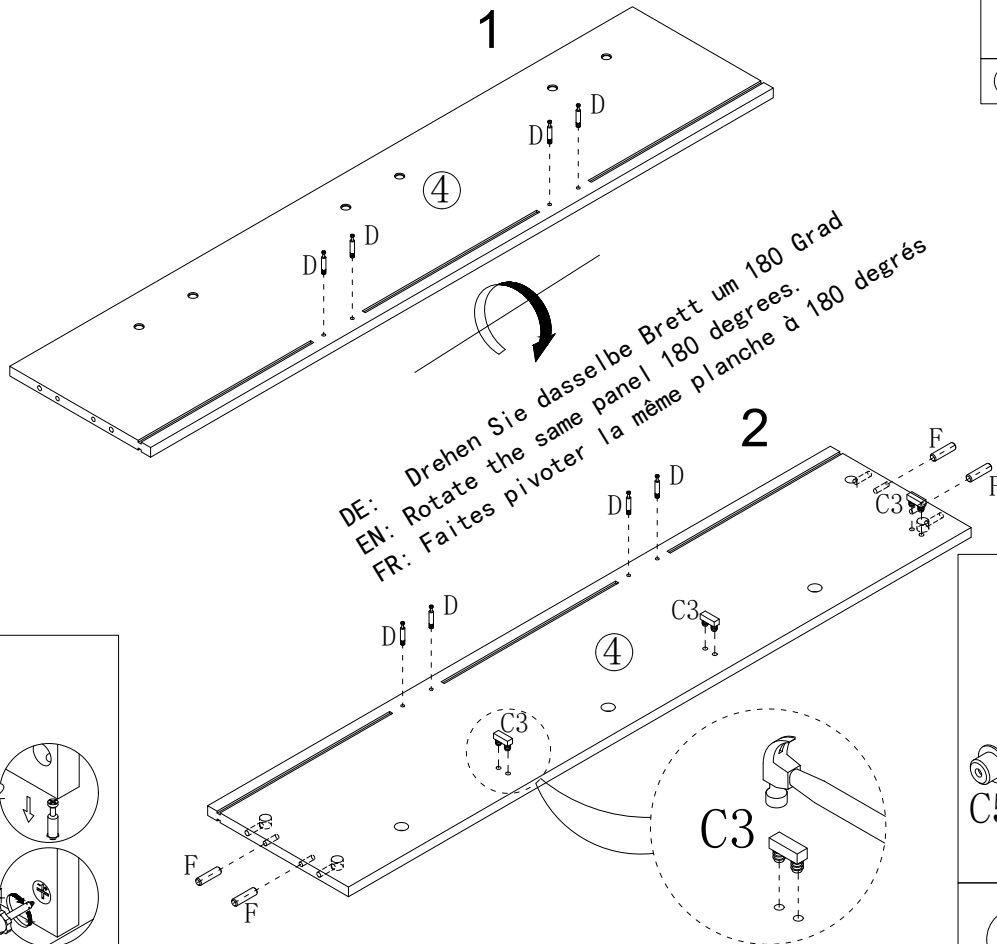

ø6*30mm	M6*34mm
ⓕ x4pcs	ⓓ x8pcs

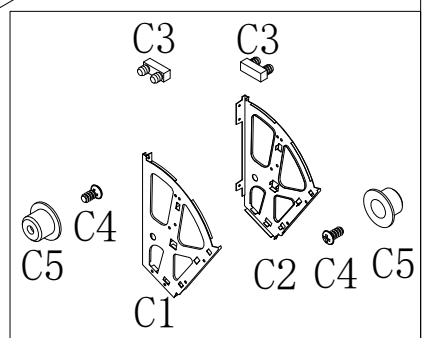
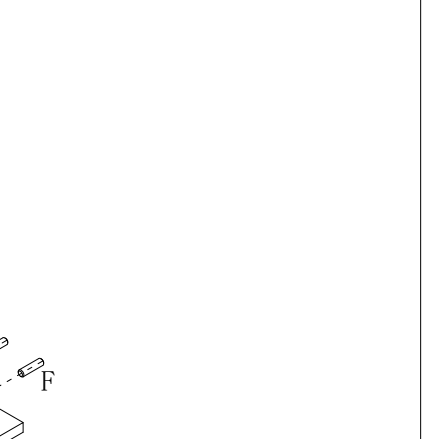

ⓐ x3pcs

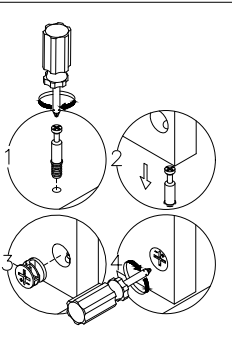

3

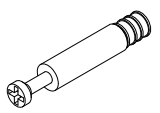
	
$\Phi 15*2\text{mm}$	M6*34mm
① x6pcs	② x12pcs

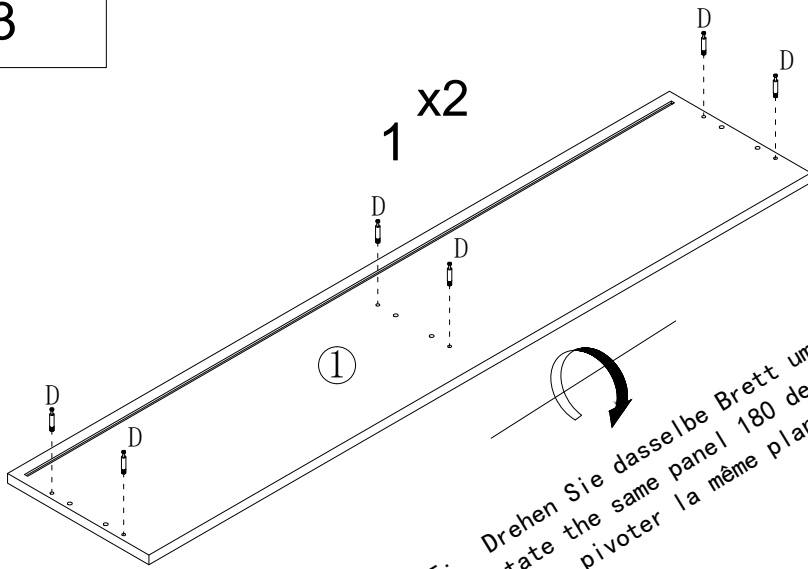

DE: Drehen Sie dasselbe Brett um 180 Grad
 EN: Rotate the same panel 180 degrees.
 FR: Faites pivoter la même planche à 180 degrés

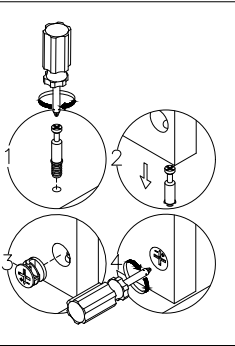
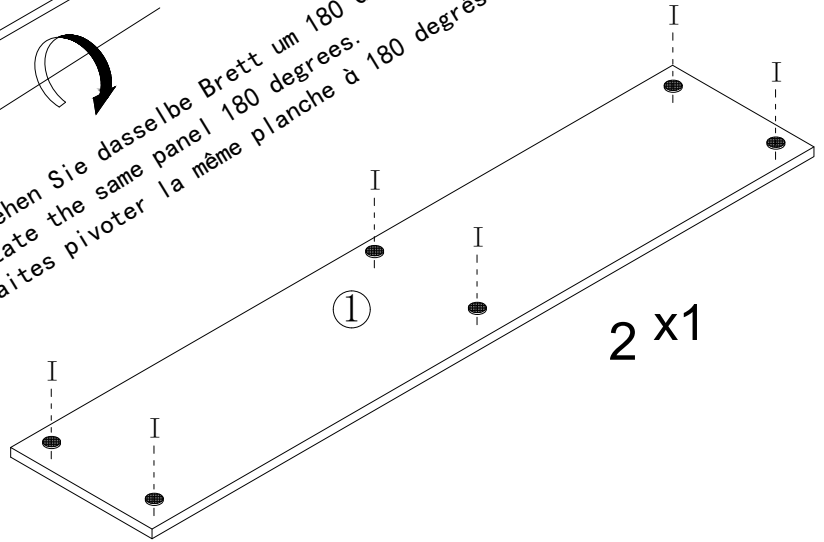

4

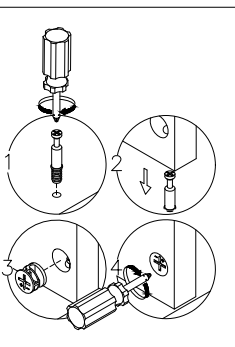
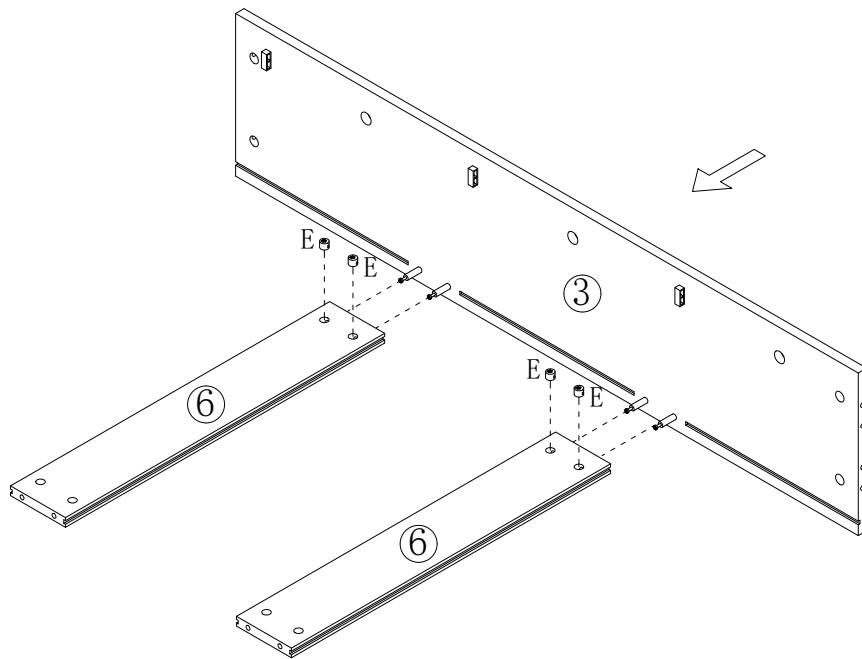

$\phi 12*10\text{mm}$
③ x4pcs

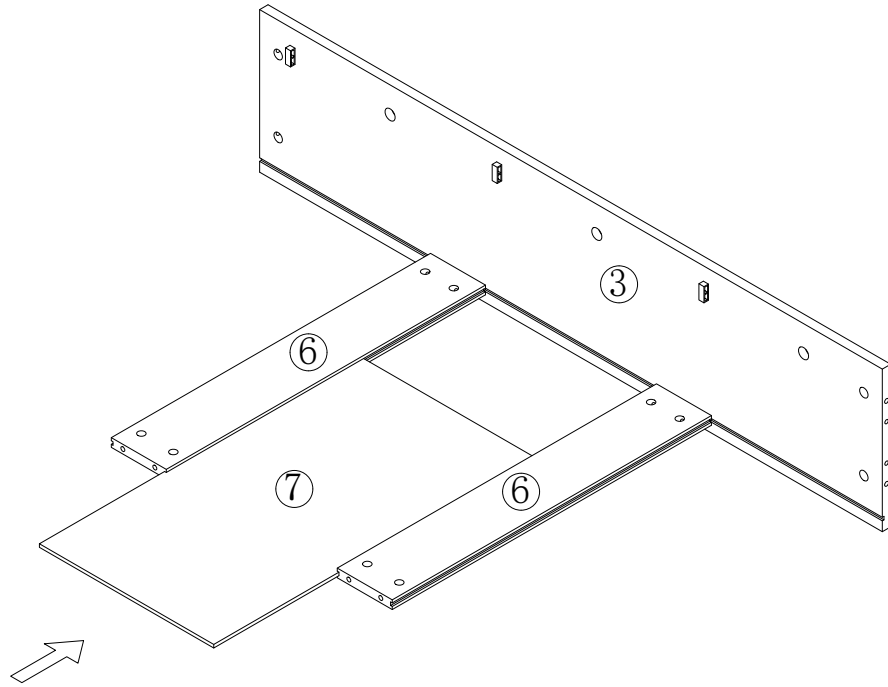

5

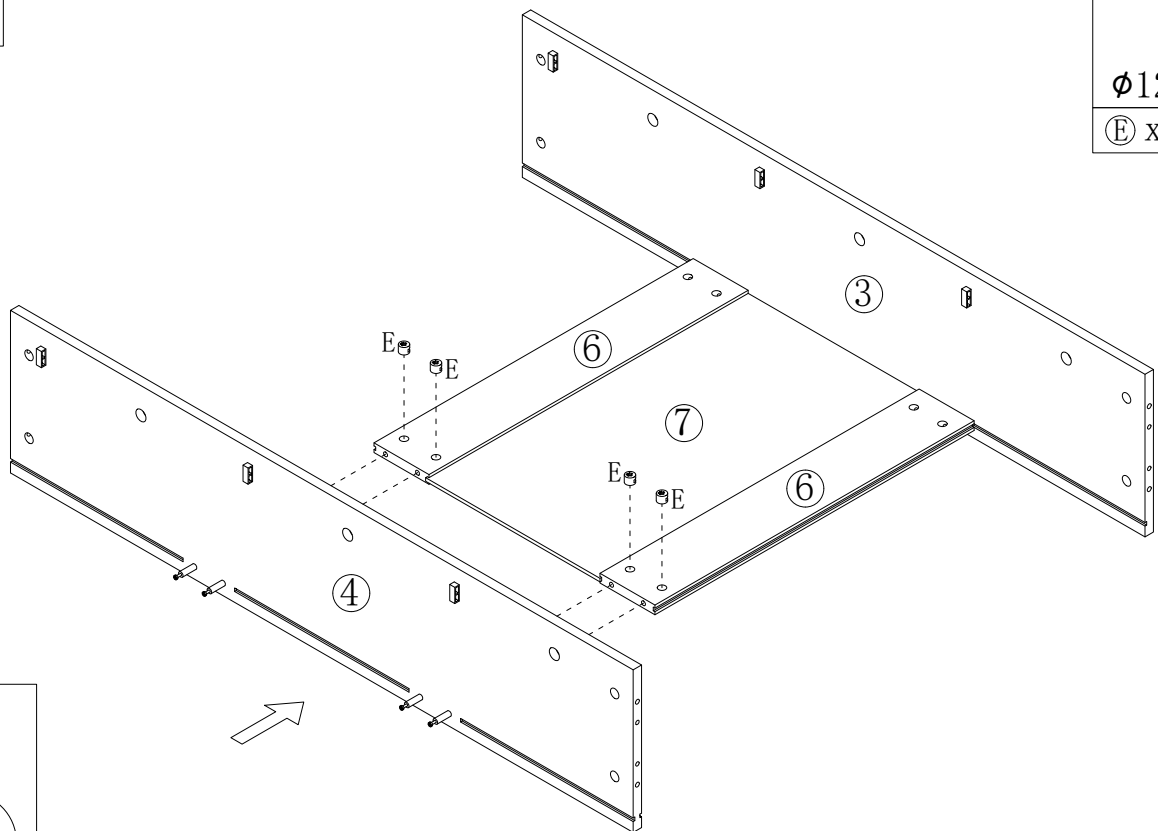

6



Ø12*10mm

ⓔ x4pcs

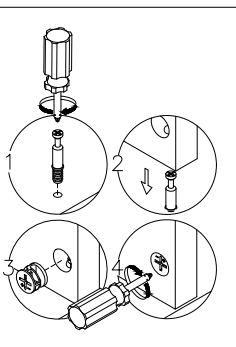

7



Ø12*10mm

ⓔ x4pcs

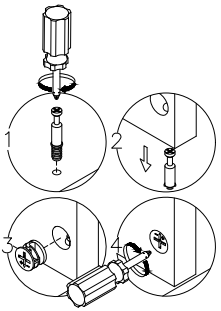
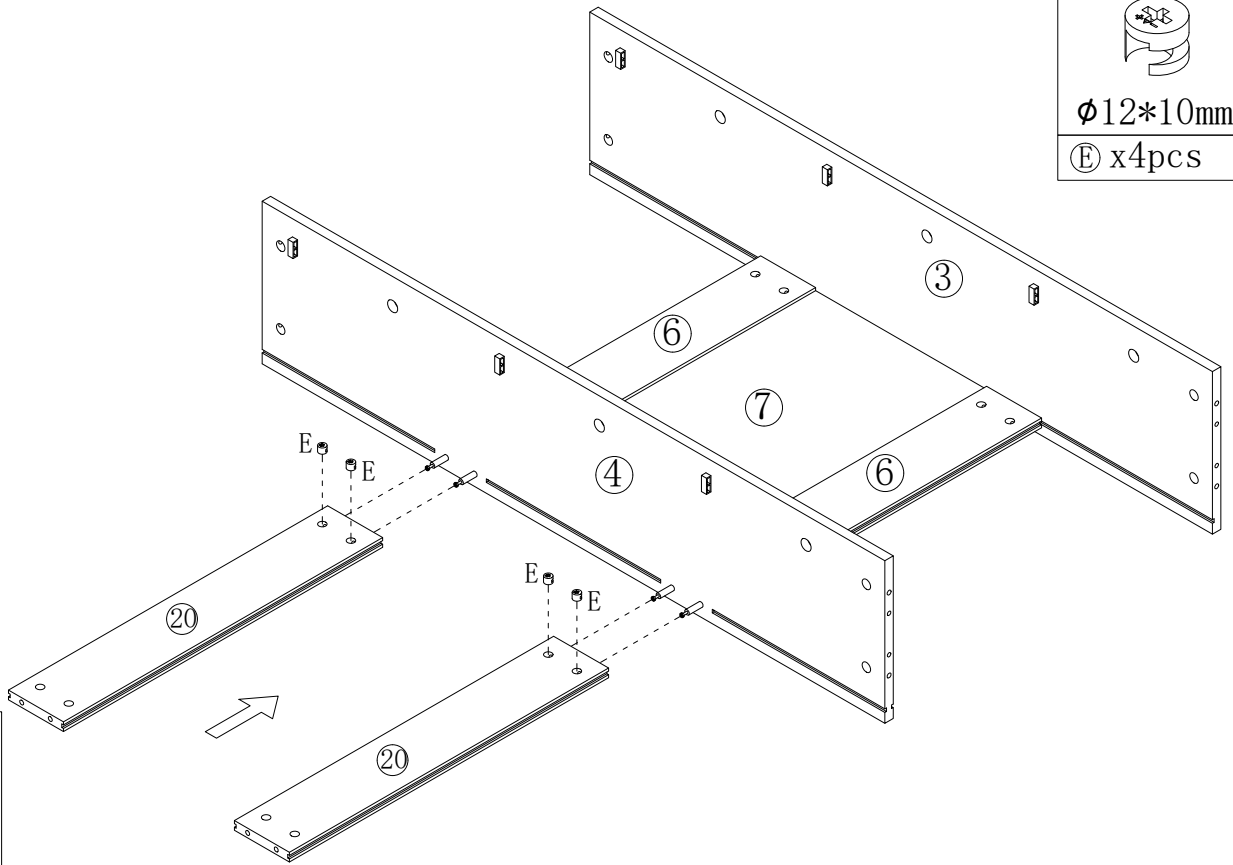

8

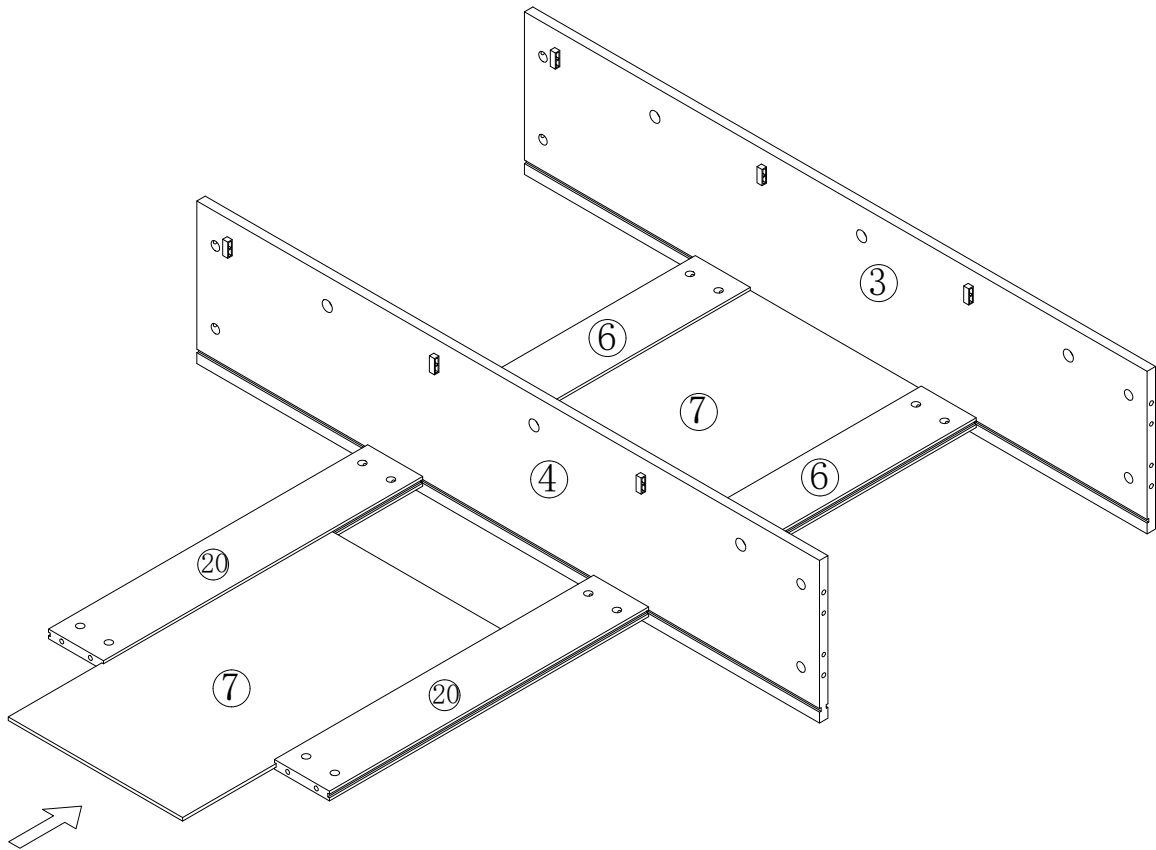

9



Ø12*10mm

ⓔ x4pcs

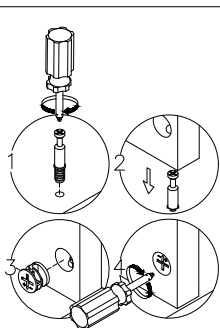
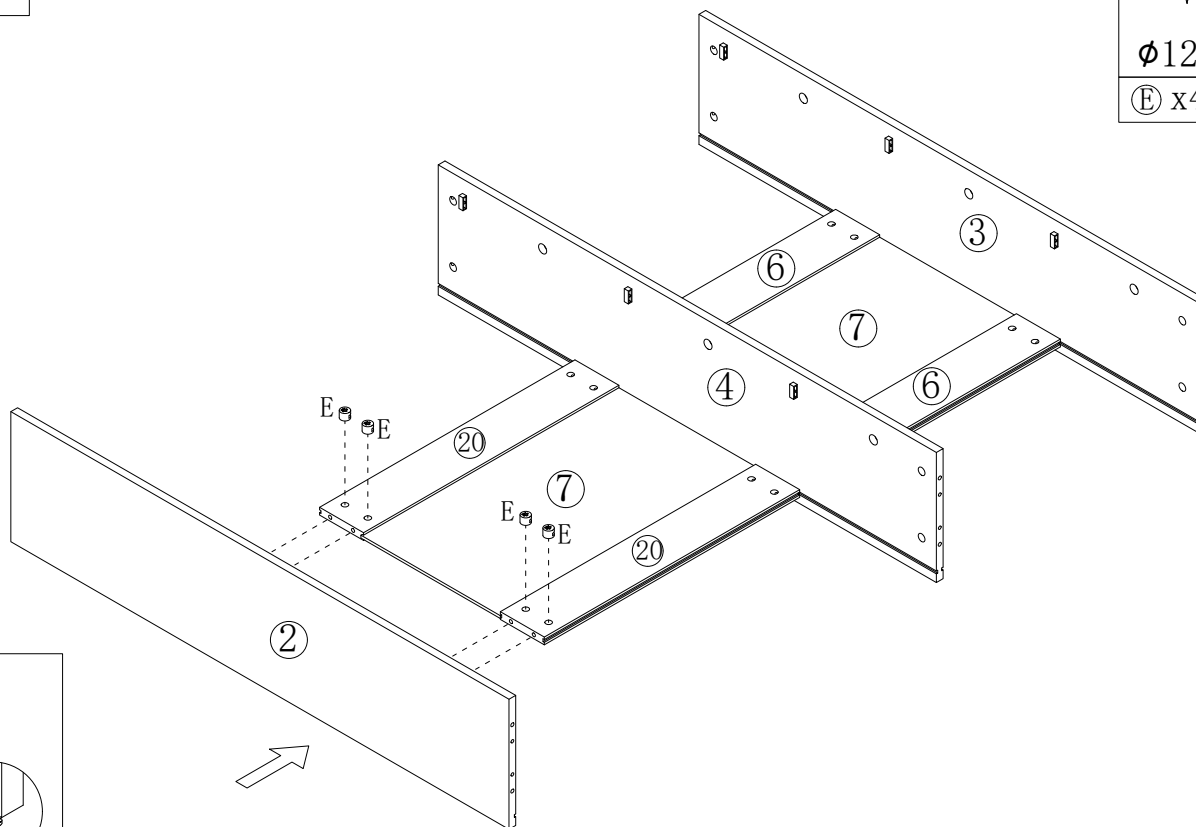

10

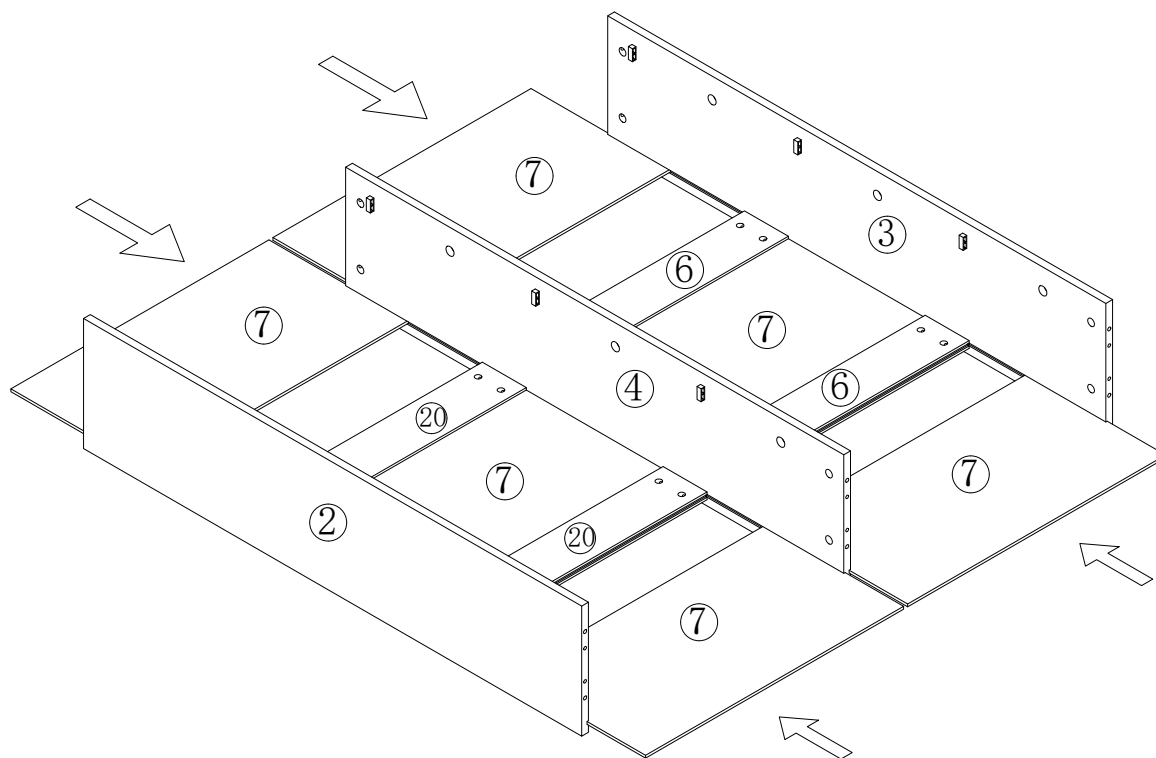

11



Ø12*10mm

ⓔ x12pcs

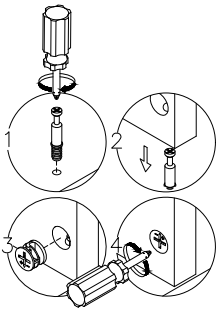
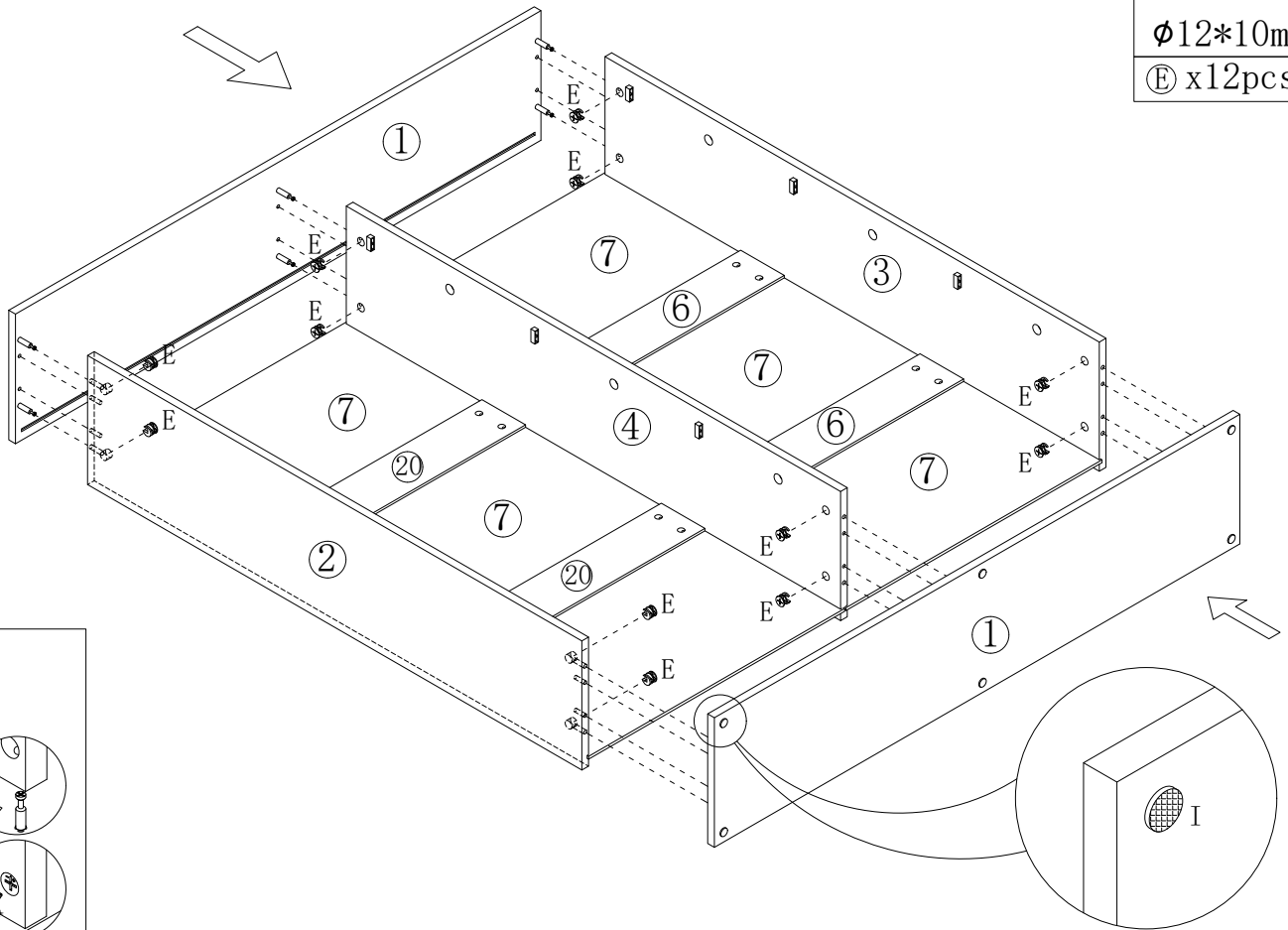

12

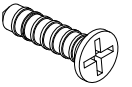

M6*22

Ⓝ x6pcs

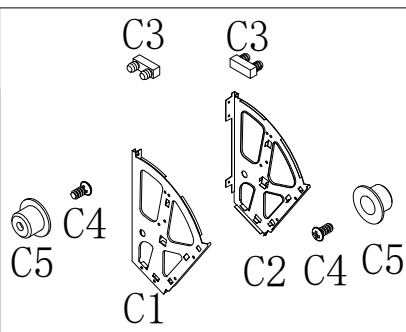
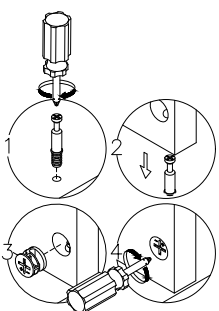
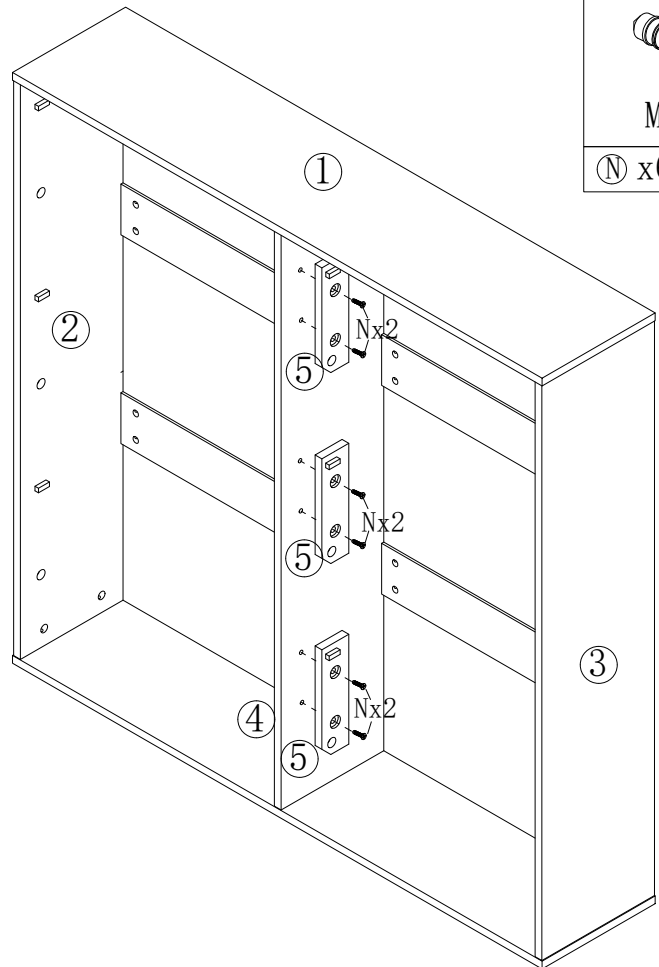
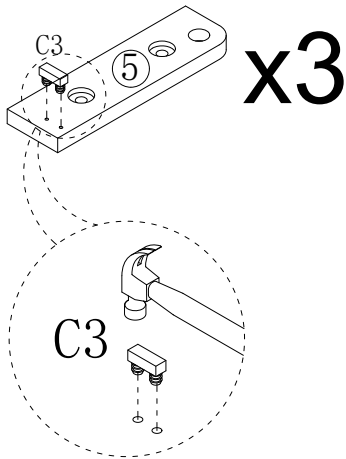

Ⓢ x3pcs

⑧ ⑩ ⑫

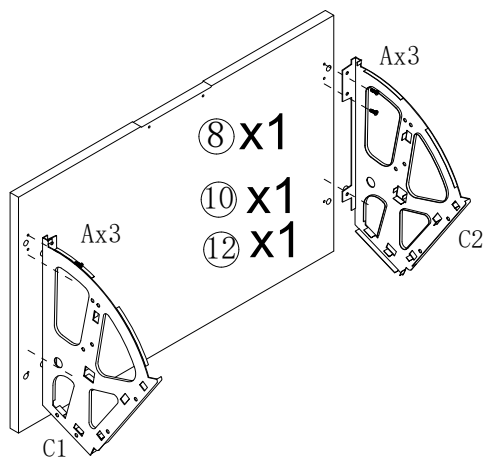
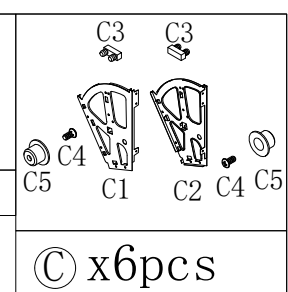
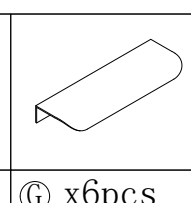
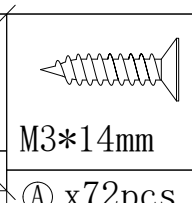
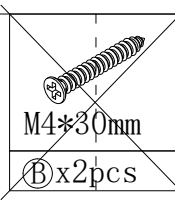

⑨ ⑪ ⑬

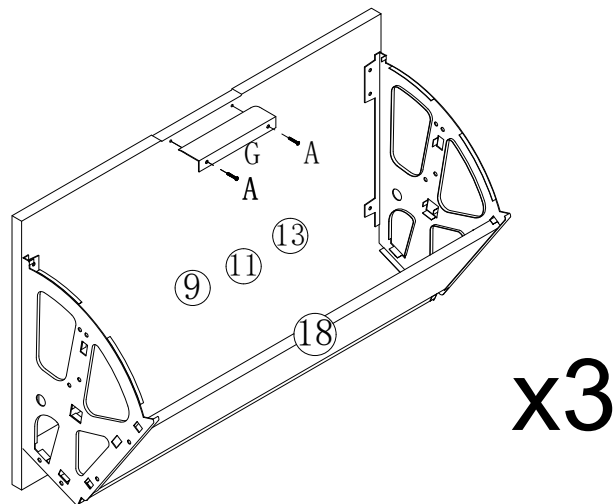
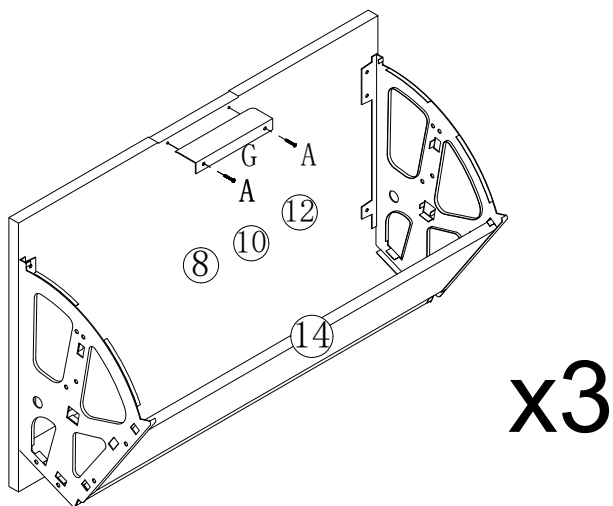
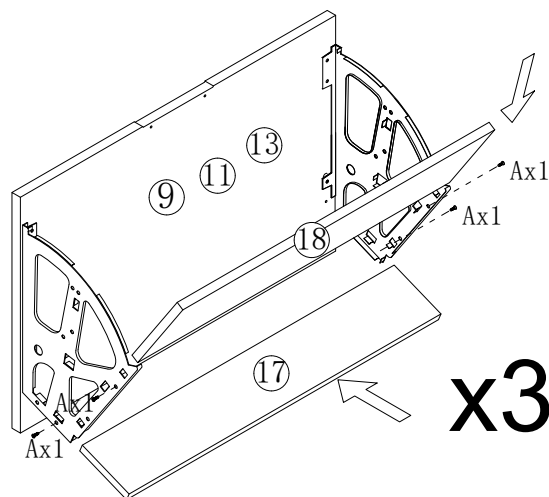
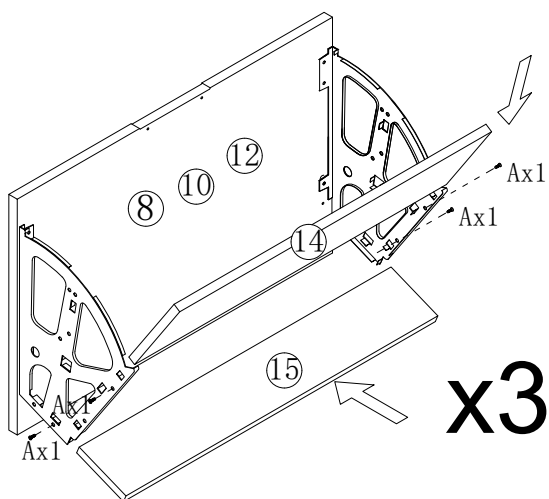
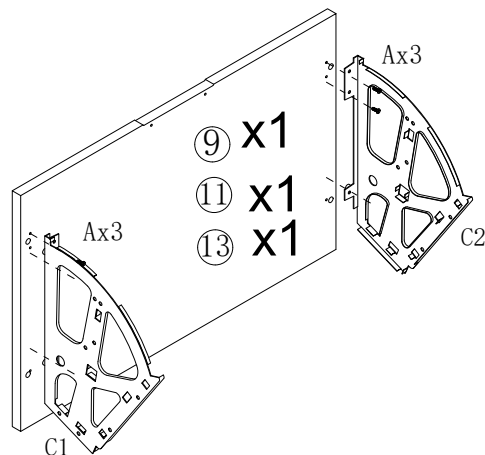

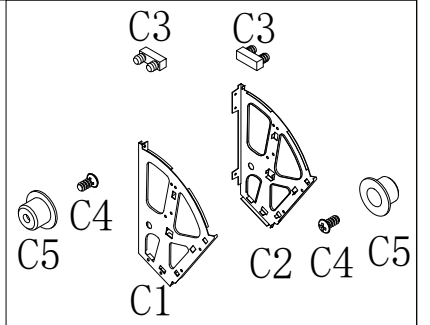

Ⓢ x3pcs

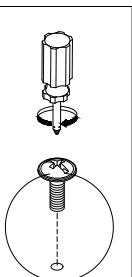
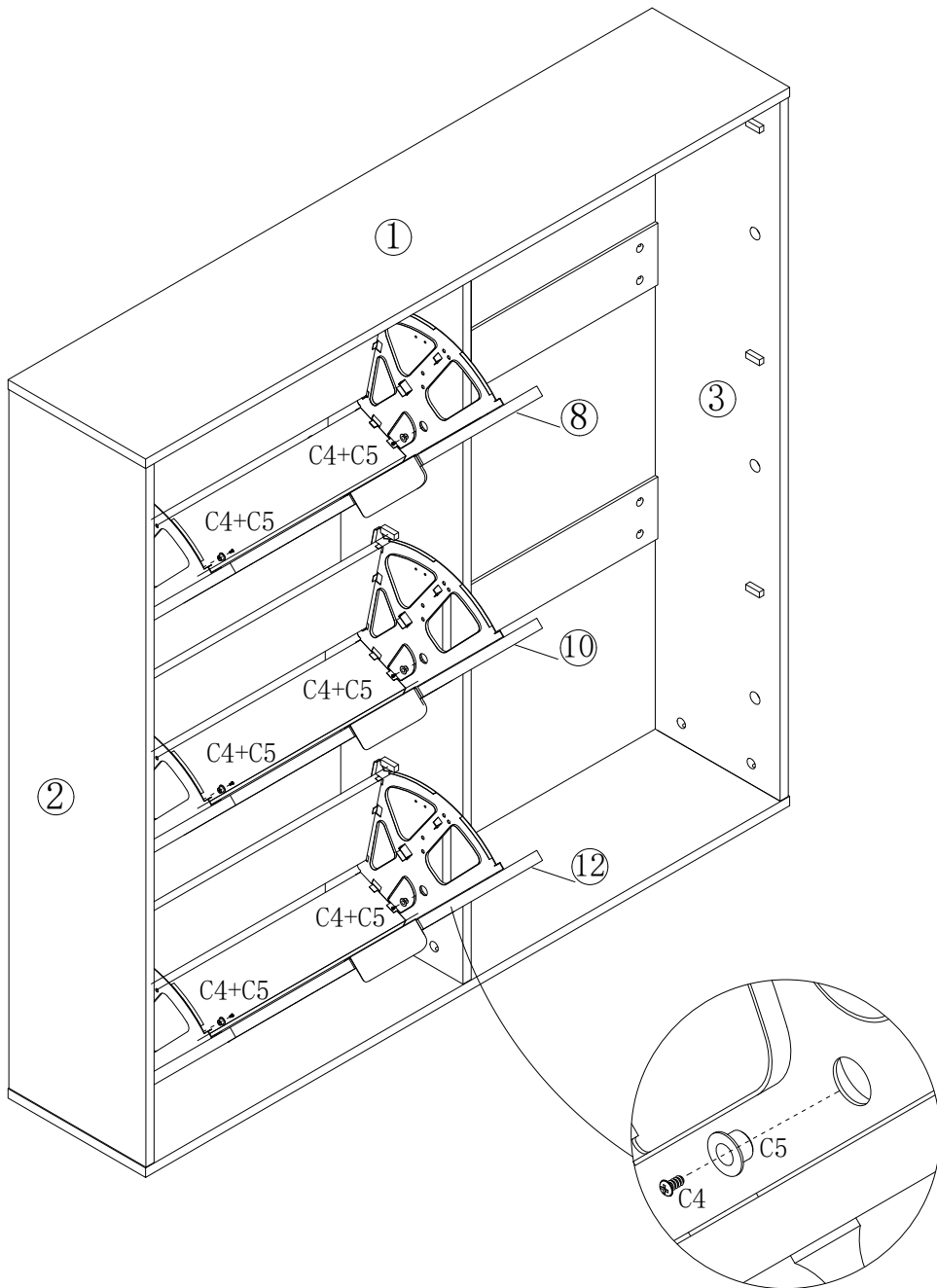

15

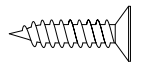

M3*14mm

Ⓐ x6pcs

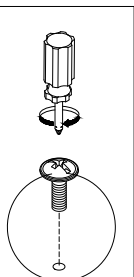
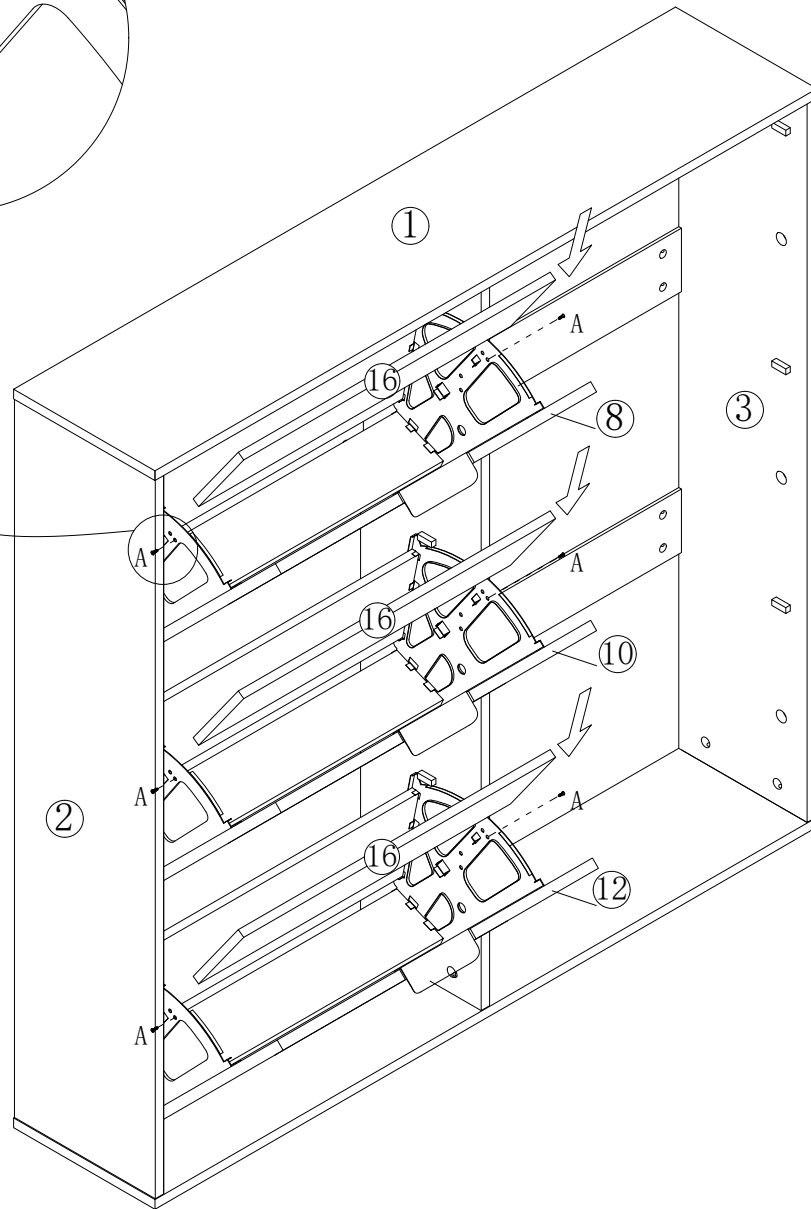
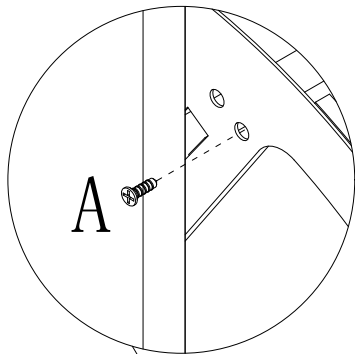

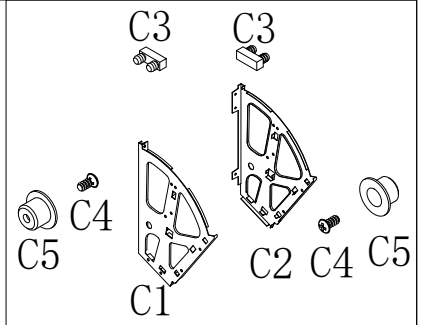

Ⓢ x3pcs

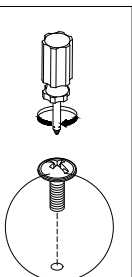
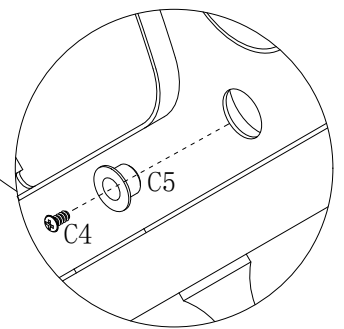
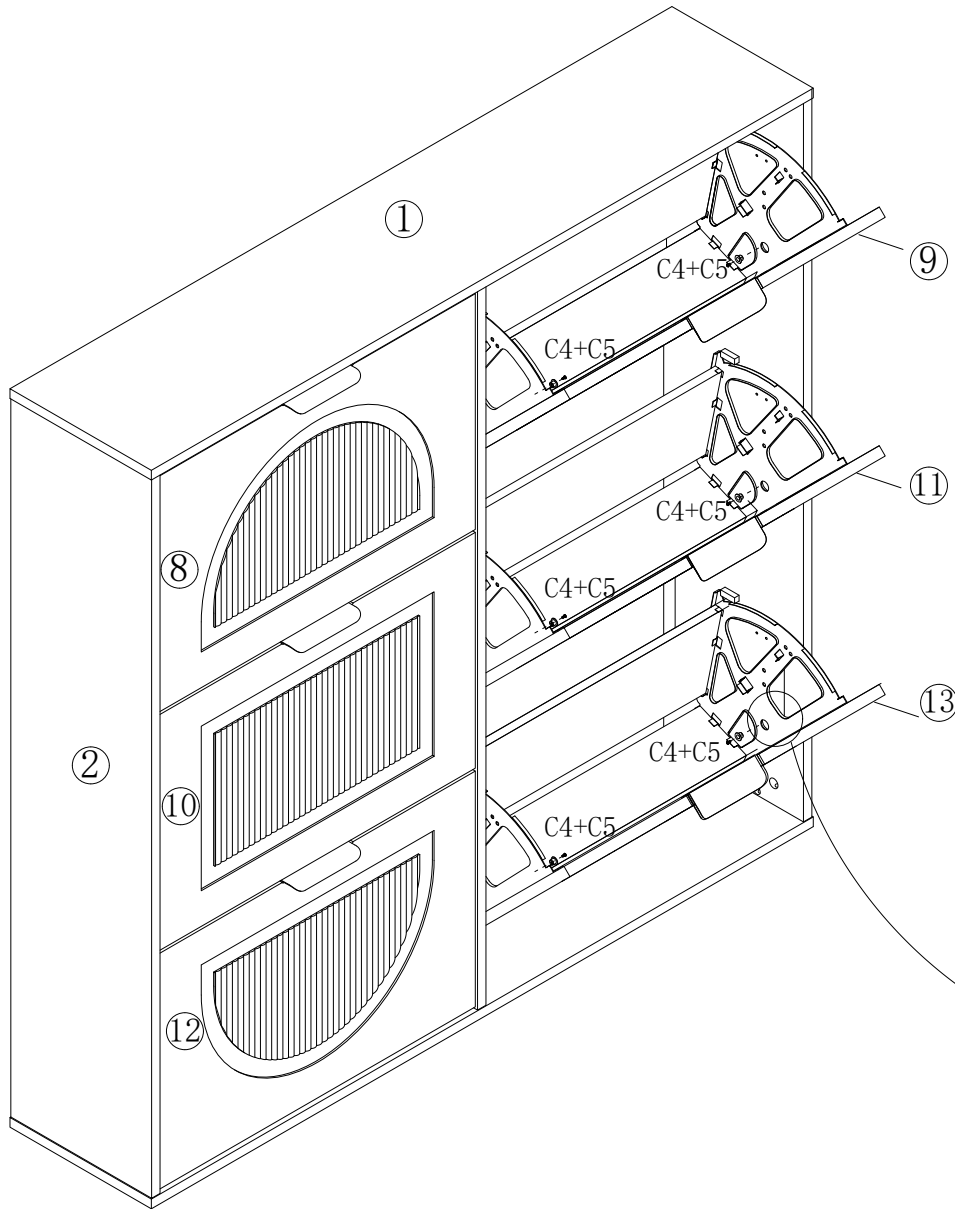

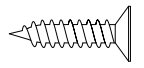

M3*14mm

Ⓐ x6pcs

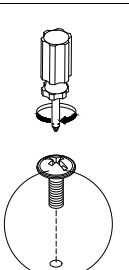
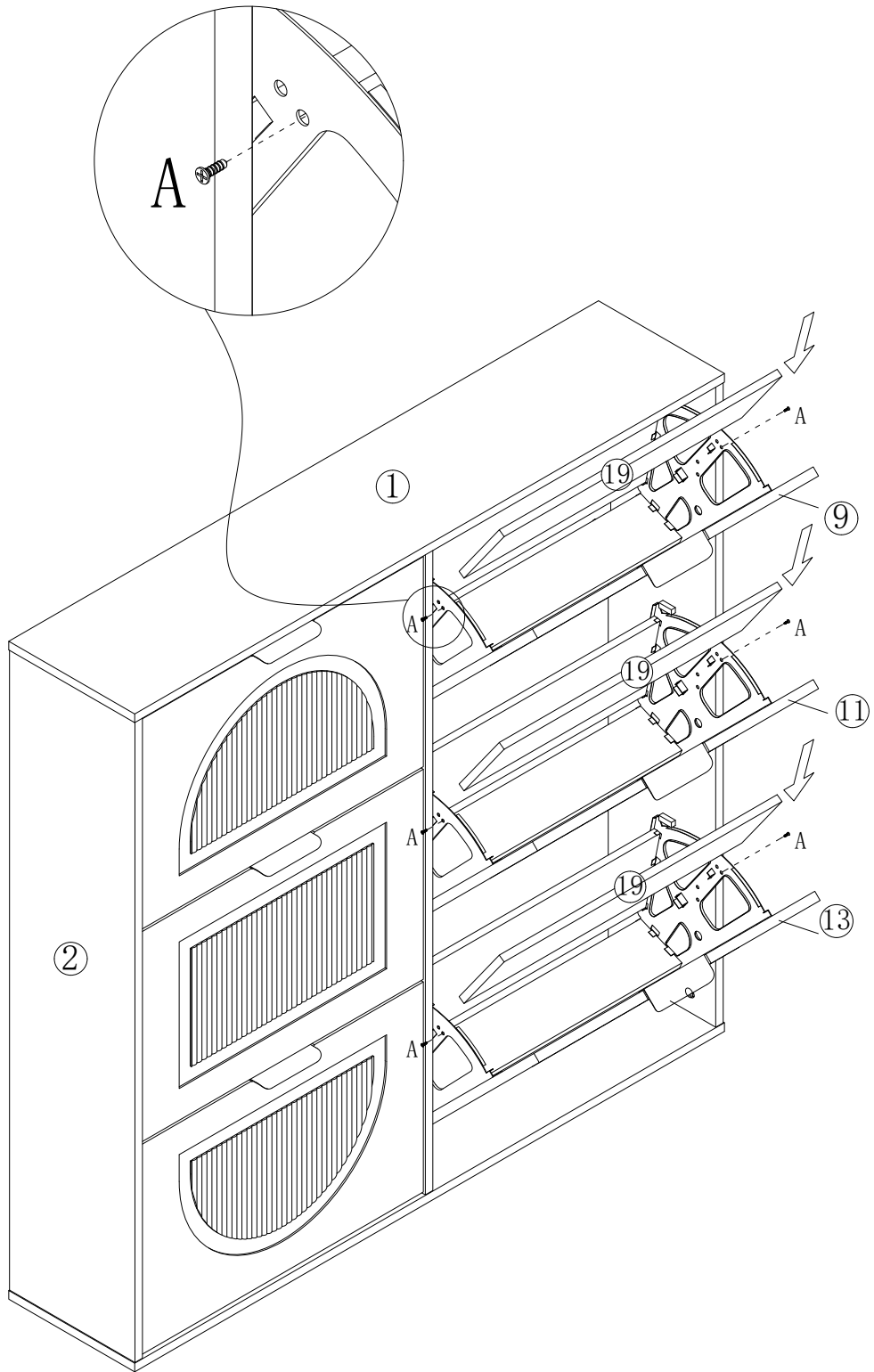

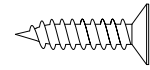

M3*14mm

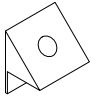

Ⓐ x24pcs

Ⓟ x24pcs

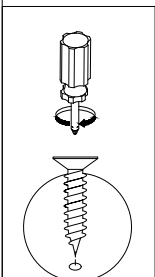
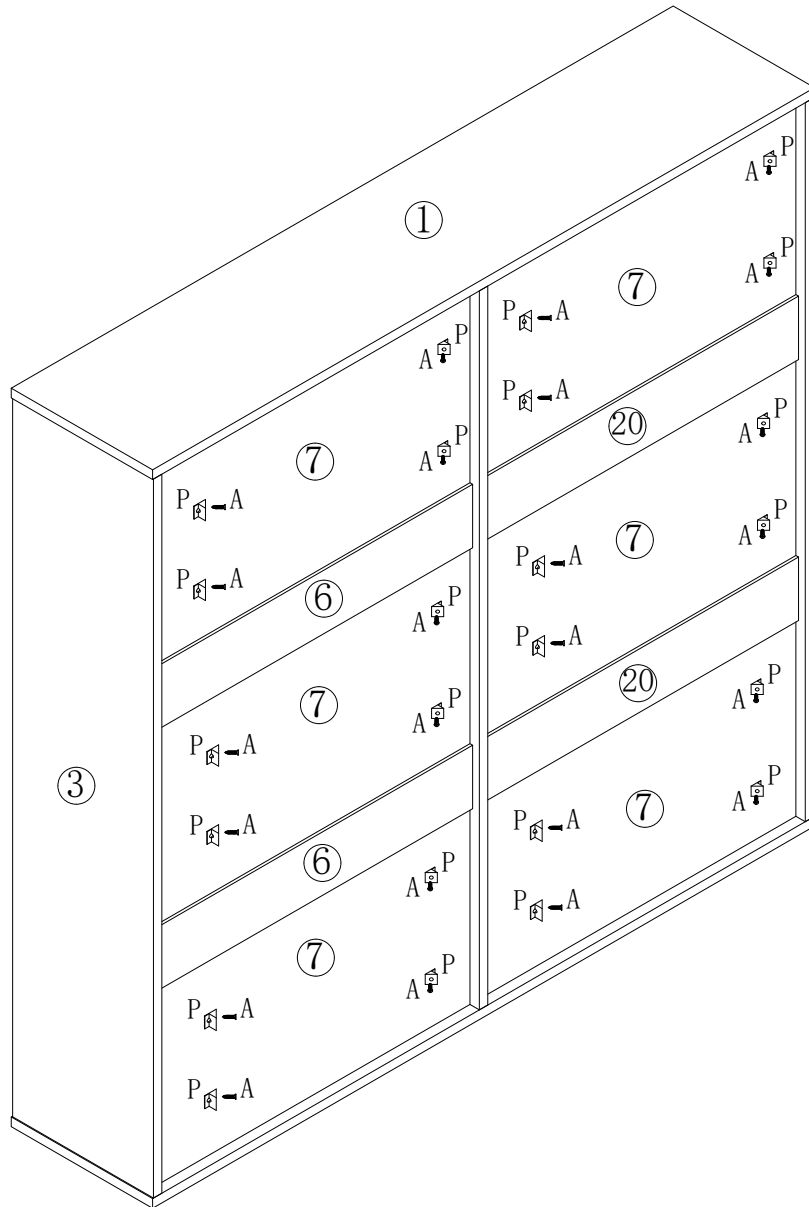

19

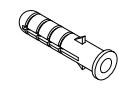
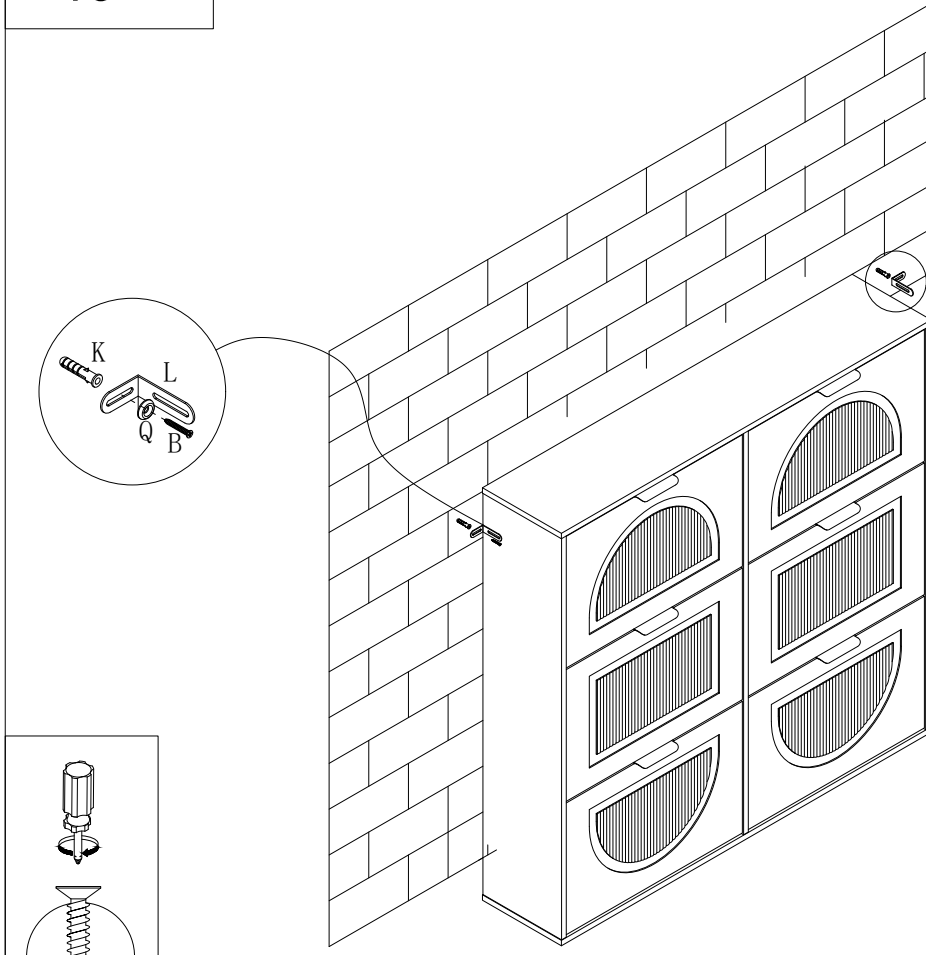

∅6*25mm

Ⓚ x2pcs

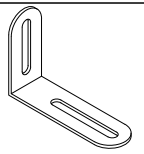

Ⓛ x2pcs

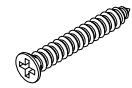

M4*30mm

ⓑ x2pcs

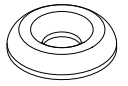

Ⓚ x2pcs

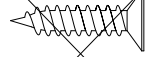

~~M3*14mm~~

~~ⓐ x2pcs~~

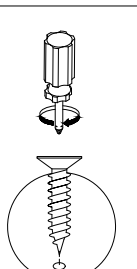
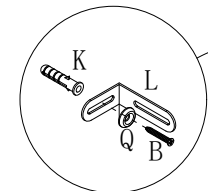
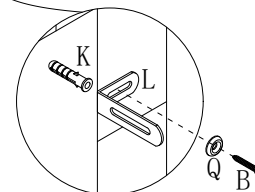

20

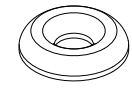
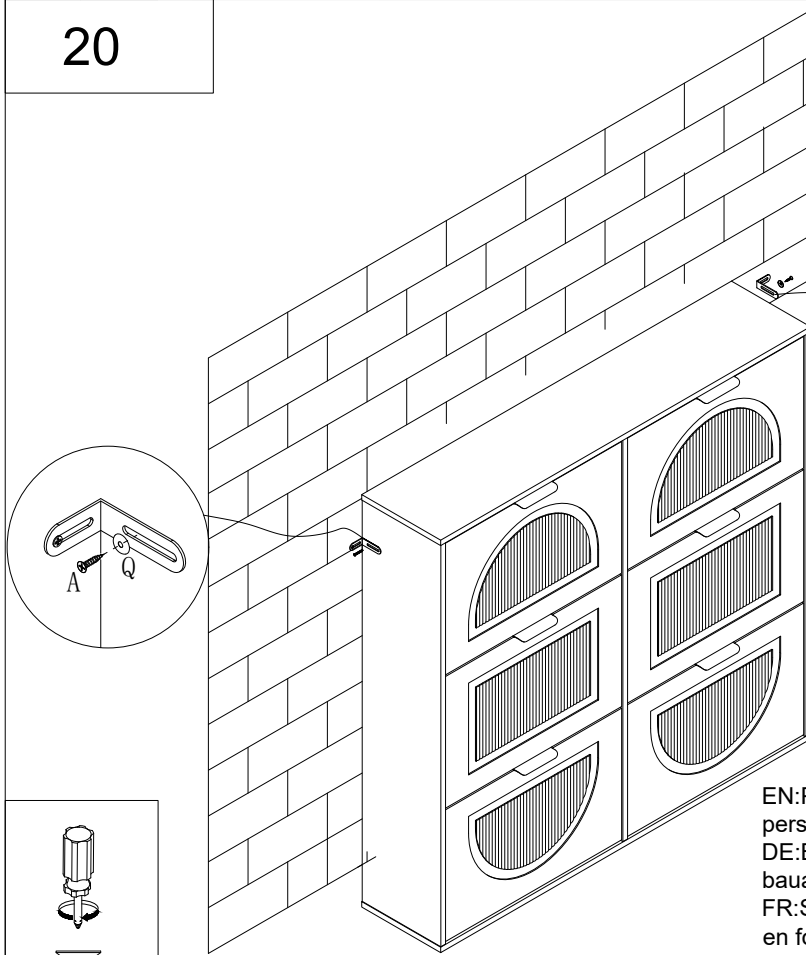

Ⓚ x2pcs

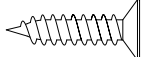

M3*14mm

ⓐ x2pcs

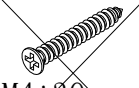

~~M4*30mm~~

~~ⓑ x2pcs~~

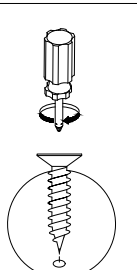
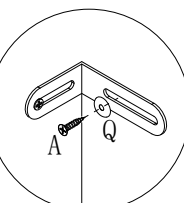
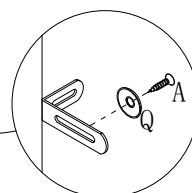

EN:Please decide whether to add anti tipping accessories based on personal needs
 DE:Bitte entscheiden sie in bezug auf ihre bedürfnisse, ob sie bauausrüstung hinzufügen sollen
 FR:S'il vous plaît décider d'ajouter des accessoires anti-basculement en fonction des besoins personnels
 IT:Decidere se aggiungere accessori anti-ribaltamento in base alle esigenze personali
 ES:Por favor, decida si desea añadir accesorios antipropinas en función de sus necesidades personales



Ⓜ x28pcs

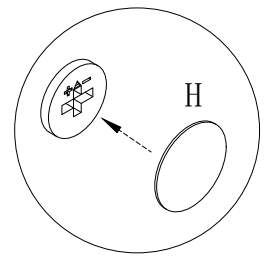
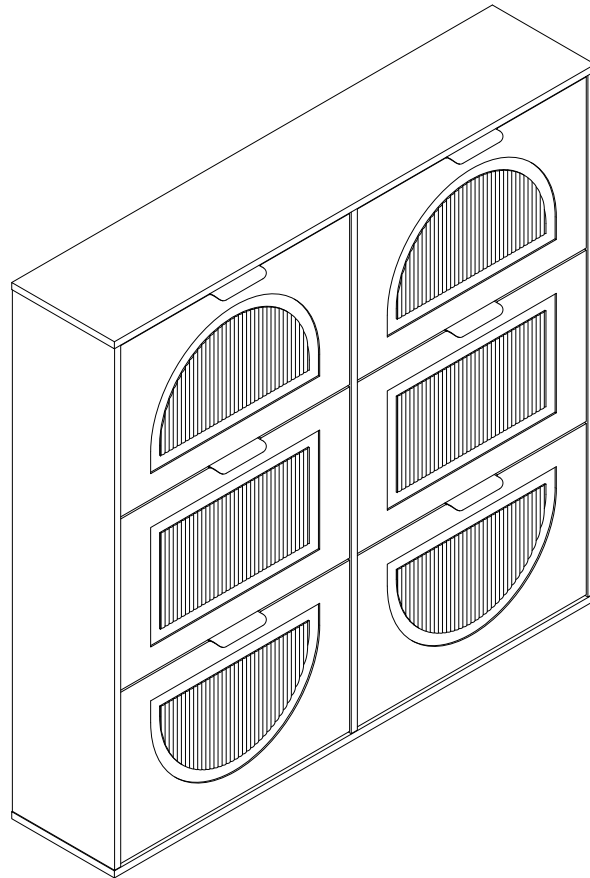

EN: In order to make the product more beautiful, please paste hardware H on the exposed holes.

DE: Um das Produkt noch schöner zu machen, kleben Sie bitte Hardware H auf die freiliegenden Löcher.

FR: Afin de rendre le produit plus beau, s'il vous plaît coller le matériel H sur les trous exposés.

IT: Per rendere il prodotto più bello, incollare l'hardware H sui fori esposti.

ES: Con el fin de hacer el producto más hermoso, por favor pega hardware H en los agujeros expuestos

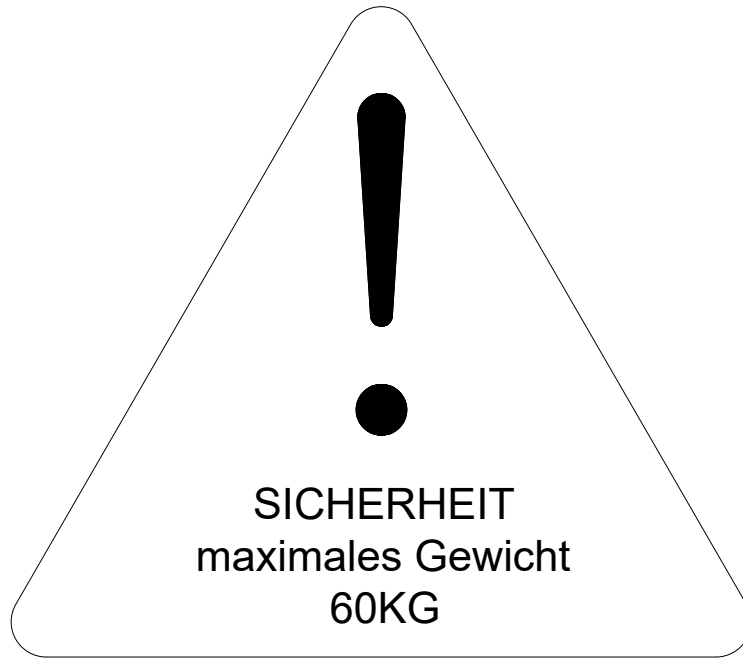

DE

Warnung: Die maximale Belastbarkeit dieses Möbels beträgt:
60 kg, bitte nicht überlasten!

EN

Warning: The maximum load-bearing capacity of this furniture is:
60 kg, please do not overload!

FR

Avertissement : La capacité de charge maximale de ce meuble
est de :
60 kg, merci de ne pas surcharger !

IT

Attenzione: la capacità di carico massima di questo mobile è:
60 kg, non sovraccaricare!

ES

Advertencia: La capacidad máxima de carga de este mueble es:
60 kg, no lo sobrecargue!

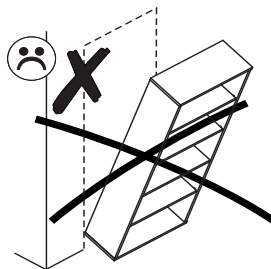
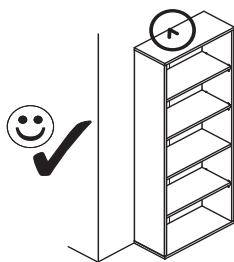

PL.

UWAGA! Mebel należy trwale zamocować do ściany, aby uniknąć ryzyka związanego z przewróceniem się mebla. W paczce znajdują się elementy mocujące odpowiednie wytycznie do ścian betonowych lub z pełnej cegły.

Jeśli Twoja ściana wykonana jest z innego materiału lub nie masz pewności co do budowy tej ściany, skonsultuj się w kwestii montażu ze specjalistą.

D.

ACHTUNG! Um alle mit dem Umkippen des Möbels verbundenen Risiken auszuschließen, muss das Möbel fest an der Wand verankert werden.

Die im Paket enthaltenen Beschläge für die Wandbefestigung sind ausschließlich für Wände aus Beton oder Vollziegeln geeignet. Sollten die heimischen Wände aus anderem Baumaterial bestehen oder sollte es Zweifel in Hinsicht auf dieses Baumaterial geben, bitte eine Fachkraft zu Rate ziehen.

FR.

ATTENTION! Ce meuble doit être fixé en permanence au mur pour éviter les risques de chute. L'ensemble comprend des moyens de fixation adaptés uniquement aux murs de béton ou de brique. Si votre mur est fait d'un matériau différent ou si vous êtes incertain quant à la construction du mur, consultez un spécialiste.

I.

ATTENZIONE! Il mobile deve essere permanentemente fissato alla parete per evitare i rischi derivanti da un ribaltamento del mobile. La confezione contiene solo elementi di fissaggio adatti per pareti in calcestruzzo o in laterizio pieno. Se la vostra parete è realizzata in materiale diverso o avete dubbi sulla costruzione della parete, consultare uno specialista per un montaggio corretto.

RU.

ПРИМЕЧАНИЕ! Эту мебель необходимо всегда прикреплять к стене, чтобы избежать рисков, связанных с переворотом мебели. В пакете находятся крепительные элементы, которые подходят исключительно к бетонным стенам или из целого кирпича. Если стена изготовлена из другого материала или Вы не уверены относительно строения стены, проконсультируйтесь относительно монтажа со специалистом.

EN.

WARNING! To prevent this furniture from tripping over, fix it to the wall permanently. The package includes fastening elements only suitable for concrete or full-brick walls. If your wall is made of a different material or you are unsure as to the construction of the wall, please consult a specialist regarding installation.

SK.

POZOR! Nábytok musí byť trvalo pripevnený k stene tak, aby sa zamedzilo riziku prevrátenia. V balíku sa nachádzajú upevňovacie komponenty výlučne pre betónové steny alebo steny z plnej tehly. Ak je Vaša stena z iného materiálu alebo ak si nie ste istí, z čoho je stena vyhotovená, vyžiadajte si odbornú pomoc.

CZ.

POZOR! Nábytek je nutné pevně připevnit ke zdi, abychom se vyhnuli riziku spojenému s jeho převrnutím. V balíčku se nacházejí připevňující prvky vhodné výhradně do betonových zdí nebo zdí z plných cihel. Pokud jsou Vaše zdi zhotoveny z jiného materiálu nebo si nejste jejich konstrukcí jisti, konzultujte otázku montáže se specialistou.

RO.

ATENȚIE! Mobila trebuie ancorată permanent în perete pentru a evita riscul de răsturnare a mobilei. Pachetul conține elementele de fixare potrivite numai pentru pereții din beton sau din cărămidă solidă. Dacă peretele Dvs. este realizat dintr-un alt material sau nu sunteți sigur care este structura peretelui, consultați un specialist în privința montajului.

NL.

OPMERKING! De meubelen moeten permanent aan de muur worden bevestigd om te voorkomen dat de meubelen kantelen. Het pakket bevat bevestigings-elementen die alleen geschikt zijn voor betonnen of massieve bakstenen muren. Als uw muur van een ander materiaal is gemaakt of als u niet zeker bent over de constructie van deze muur, raadpleeg dan een specialist voor de installatie.

TR.

DİKKAT! Devrilmeye riskini önlemek için mobilya duvara sabitlenmelidir. Pakette, sadece beton veya tam tuğla duvarlara uygun sabitleme elemanları bulunmaktadır. Eğer duvarınız başka bir malzeme ile yapıldıysa veya duvar yapısından emin değilseniz, montaj konusunda bir uzmana danışınız.

AR.

ملاحظة!

يجب تثبيت الأثاث بإحكام إلى الحائط أو الجدار لتجنب خطر انقلابه. تحتوي العبوة على مسامير التثبيت التي تناسب الجدران الخرسانية أو الطوب. إذا كان جدارك مصنوعاً من مادة مختلفة أو لم تكن متأكدًا من مادة بنائه اسأل المتخصص عن كيفية التثبيت.

E.

¡ATENCIÓN! El mueble debe ser fijado permanentemente a la pared para evitar el riesgo relacionado con el vuelco del mueble. En el paquete hay elementos de fijación adecuados solo para paredes de hormigón o de ladrillo entero. Si su pared está hecha de otro material o no está seguro sobre la construcción de esta pared, consulte el montaje con un especialista.

CN.

注意！本家具需要固定在墙上以免倒塌。本包所包含的固定部件仅适用于混凝土墙及整砖墙。欲使用在其他墙体或不确定墙体时，请向专家询问安装方式。

HR.

NAPOMENA! Namještaj mora biti trajno pričvršćen za zid, kako bi se izbjegao rizik od njegova prevrtanja. U paketu se nalaze elementi za pričvršćivanje prikladni isključivo za betonske zidove ili punu ciglu. Ako je Vaš zid izrađen od drugog materijala ili niste sigurni od čega je napravljen Vaš zid, konzultirajte se sa stručnjakom u vezi sa montažom.

SLO.

POZOR! Pohištvo trajno pritrdite na steno, da preprečite tveganje, da se prevrne. V paketu so pritrđilni elementi, ki so ustrezni izključno za betonske stene in za stene iz polne opeke. Če je vaša stena izdelana iz drugih materialov ali niste gotovi glede konstrukcije stene, se o montaži posvetujte s strokovnjakom.

HU.

FIGYELEM! Rögzítse a bútorokat a falhoz, hogy elkerülje a bútor felborulásának kockázatát. A készletben kizárólag beton- vagy téglafalhoz használható kötőelemek találhatók. Ha a fal más anyagból készült, vagy ha nem tudja, milyen falak találhatók otthonában, forduljon szakemberhez.