

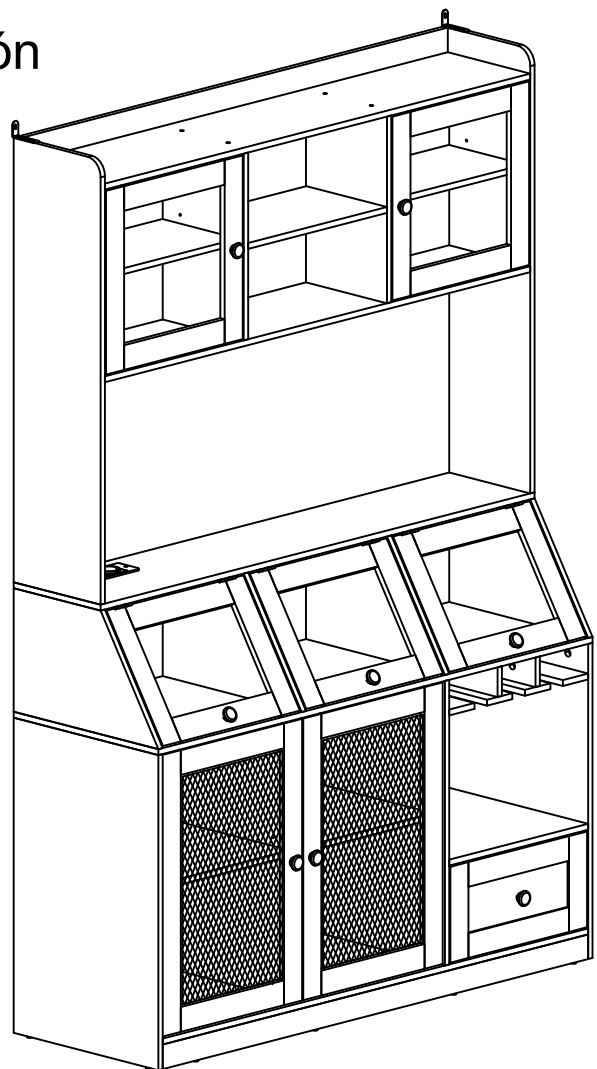



ASSEMBLY INSTRUCTIONS

N620P429906 & N620P429907

DE: Installationsanleitung
UK: Installation Instruction
FR: Instruction d'installation
IT: Istruzioni di installazione
ES: Instrucciones de instalación
NL: Installatie-instructies
SE: Installationsanvisningar
PL: Instrukcje instalacji

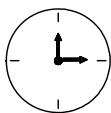
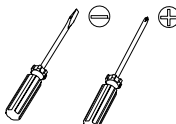
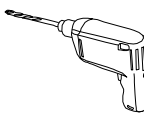
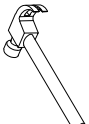

 2PERS	 120 MIN	Tool Required Not Provided     
--	--	--

DE

Unser Produkt wird Ihnen in 2 Paketen geliefert. Die Lieferzeiten dieser 2 Pakete können abweichen, bitte haben Sie etwas Geduld und vielen Dank für Ihr Verständnis

UK

Our product will be delivered to you in 2 packages. The delivery times of these 2 packages may differ, please be patient and thank you for your understanding

FR

Notre produit vous sera livré en 2 colis. Les délais de livraison de ces 2 colis peuvent différer, soyez patient et merci pour votre compréhension

IT

Il nostro prodotto verrà consegnato in 2 pacchi. I tempi di consegna di questi 2 pacchi possono variare; vi preghiamo di avere un po' di pazienza e vi ringraziamo per la vostra comprensione

ES

Nuestro producto se entregará en 2 paquetes. Los tiempos de entrega de estos 2 paquetes pueden variar; por favor, tenga un poco de paciencia y gracias por su comprensión.

NL

Ons product wordt in 2 pakketten bij u geleverd. De levertijden van deze 2 pakketten kunnen verschillen, we vragen om uw geduld en bedanken u voor uw begrip.

SE

Vår produkt kommer att levereras till dig i 2 paket. Leveranstiderna för dessa 2 paket kan variera, vi ber om ditt tålamod och tackar för din förståelse.

PL

Nasz produkt zostanie dostarczony w 2 paczkach. Czas dostawy tych 2 paczek może się różnić, prosimy o cierpliwość i dziękujemy za zrozumienie.

WARNING

(DE)

1. Die maximale Tragfähigkeit des Produkts beträgt 60 kg, bitte nicht überladen.
2. Lassen Sie Kinder nicht auf Möbel klettern, da dies Umkippen und schwere Verletzungen verursachen kann.
3. Um die Sicherheit zu gewährleisten, installieren Sie bitte gemäß der Anleitung und ziehen Sie bei Bedarf Fachleute zurate.
4. Stellen Sie Möbel nicht in die Nähe von Feuerquellen oder heißen Gegenständen, um das Brandrisiko zu vermeiden.
5. Stellen Sie Möbel nicht in feuchten Umgebungen auf, um Materialschäden zu verhindern.
6. Überprüfen Sie regelmäßig alle Verbindungen und Befestigungen, um sicherzustellen, dass sie fest sind, um Unfälle zu vermeiden.
7. Reinigen Sie Möbel mit einem feuchten Tuch oder Alkohol, vermeiden Sie die Verwendung von reinigenden Mitteln mit ätzenden Chemikalien.

(UK)

1. The maximum weight capacity of the product is 60kg; do not overload.
2. Do not allow children to climb on furniture, as it may cause tipping and serious injury.
3. For safety, please install correctly according to the instructions, and seek professional assistance if necessary.
4. Do not place furniture near fire sources or hot items to avoid fire risk.
5. Do not place furniture in damp environments to prevent material damage.
6. Regularly check all connections and fasteners to ensure they are secure to prevent accidents.
7. Clean furniture with a damp cloth or alcohol; avoid using cleaners with corrosive chemicals.

(FR)

1. La capacité maximale de charge du produit est de 60 kg, ne pas surcharger.
2. Ne laissez pas les enfants grimper sur les meubles, cela peut entraîner un basculement et des blessures graves.
3. Pour garantir la sécurité, veuillez installer correctement selon les instructions et demander de l'aide à des professionnels si nécessaire.
4. Ne placez pas les meubles près de sources de chaleur ou d'objets chauds pour éviter les risques d'incendie.
5. Ne placez pas les meubles dans des environnements humides pour éviter d'endommager les matériaux.
6. Vérifiez régulièrement tous les raccords et fixations pour vous assurer qu'ils sont sécurisés afin d'éviter les accidents.
7. Nettoyez les meubles avec un chiffon humide ou de l'alcool, évitez d'utiliser des nettoyants contenant des produits chimiques corrosifs.

WARNING

(IT)

1. La capacità massima del prodotto è di 60 kg, non sovraccaricare.
2. Non permettere ai bambini di arrampicarsi sui mobili, poiché ciò potrebbe causare ribaltamenti e gravi infortuni.
3. Per garantire la sicurezza, installare correttamente secondo le istruzioni e chiedere assistenza a professionisti se necessario.
4. Non posizionare i mobili vicino a fonti di calore o oggetti caldi per evitare rischi di incendio.
5. Non posizionare i mobili in ambienti umidi per prevenire danni ai materiali.
6. Controllare regolarmente tutte le connessioni e le viti per assicurarsi che siano sicure e prevenire incidenti.
7. Pulire i mobili con un panno umido o alcol; evitare di utilizzare detergenti contenenti sostanze chimiche corrosive.

(ES)

1. La capacidad máxima del producto es de 60 kg, no sobrecargar.
2. No permita que los niños escalen los muebles, ya que puede provocar vuelcos y lesiones graves.
3. Para garantizar la seguridad, instale correctamente según las instrucciones y busque asistencia profesional si es necesario.
4. No coloque muebles cerca de fuentes de fuego u objetos calientes para evitar riesgos de incendio.
5. No coloque muebles en ambientes húmedos para evitar daños en los materiales.
6. Revise regularmente todas las conexiones y sujetadores para asegurarse de que estén firmes y prevenir accidentes.
7. Limpie los muebles con un paño húmedo o alcohol; evite usar limpiadores con productos químicos corrosivos.

(NL)

1. De maximale draagcapaciteit van het product is 60 kg; niet overbelasten.
2. Laat kinderen niet op meubels klimmen, dit kan omvallen en ernstige verwondingen veroorzaken.
3. Installeer correct volgens de instructies voor de veiligheid en vraag indien nodig om professionele hulp.
4. Plaats meubels niet in de buurt van vuurbronnen of hete voorwerpen om brandrisico te voorkomen.
5. Plaats meubels niet in vochtige omgevingen om materiaalschade te voorkomen.
6. Controleer regelmatig alle verbindingen en bevestigingen om ervoor te zorgen dat ze stevig zijn en ongelukken te voorkomen.
7. Maak meubels schoon met een vochtige doek of alcohol; vermijd het gebruik van schoonmaakmiddelen met bijtende chemicaliën.

WARNING

(SE)

1. Den maximala belastningen för produkten är 60 kg; överbelasta inte.
2. Låt inte barn klättra på möbler, eftersom det kan leda till att de tippas och orsakar allvarliga skador.
3. För att säkerställa säkerheten, installera korrekt enligt instruktionerna och be om professionell hjälp vid behov.
4. Placera inte möbler nära värmekällor eller heta föremål för att undvika brandrisk.
5. Placera inte möbler i fuktiga miljöer för att förhindra materialskador.
6. Kontrollera regelbundet alla anslutningar och fästen för att säkerställa att de är säkra för att förhindra olyckor.
7. Rengör möbler med en fuktig trasa eller alkohol; undvik att använda rengöringsmedel med frätande kemikalier.

(PL)

1. Maksymalne obciążenie produktu wynosi 60 kg; nie przeciążaj.
2. Nie pozwalaj dzieciom wspinąć się na meble, ponieważ może to prowadzić do przewrócenia i poważnych obrażeń.
3. Aby zapewnić bezpieczeństwo, zainstaluj poprawnie zgodnie z instrukcjami i w razie potrzeby skorzystaj z pomocy specjalistów.
4. Nie stawiaj mebli w pobliżu źródeł ognia lub gorących przedmiotów, aby uniknąć ryzyka pożaru.
5. Nie umieszczaj mebli w wilgotnym środowisku, aby zapobiec uszkodzeniu materiałów.
6. Regularnie sprawdzaj wszystkie połączenia i mocowania, aby upewnić się, że są solidne, aby zapobiec wypadkom.
7. Czyść meble wilgotną szmatką lub alkoholem; unikaj używania środków czyszczących z żrącymi chemikaliami.

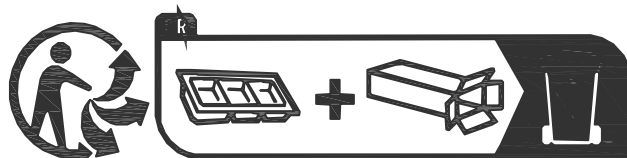
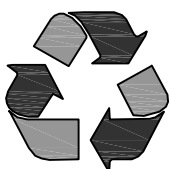

DE: Vor dem Einbau die Schrauben in die Löcher stecken und festziehen, aber nicht bis 100%, 70% bis 80% anziehen reicht aus. Schließlich, nachdem alle Schrauben installiert sind, ziehen Sie alle Schrauben auf 100%.

Wenn Sie auf diese Probleme stoßen, wie z. B. Fehlausrichtung der Löcher oder Unfähigkeit, bestimmte Teile zu installieren, überprüfen Sie bitte, ob die Schrauben korrekt verwendet werden und passen Sie die Dichtigkeit der Schrauben an.

UK: Before installation, insert the screws into the holes and tighten them, but do not tighten them to 100%, 70% to 80% is sufficient. Finally, after all screws are installed, tighten all screws to 100%. If you encounter these issues, such as if the holes cannot be aligned or some parts cannot be installed, please check if the screws are used correctly and adjust the tightness of the screws.

FR: Insérer la vis dans le trou avant la fin de l'assemblage, serrer la vis, mais ne pas serrer à 100%, 70% ~ 80% est correct. Enfin, une fois que toutes les vis sont bien serrées, toutes les vis sont serrées à 100%. Si vous rencontrez ces problèmes, par exemple si les trous ne sont pas alignés ou si certaines pièces ne peuvent pas être montées, vérifiez que les vis sont utilisées correctement et ajustez leur serrage.

IT: Prima dell'installazione, inserire le viti nei fori e stringerle, ma non al 100%, è sufficiente stringerle al 70% - 80%. Infine, dopo aver installato tutte le viti, stringere tutte le viti al 100%. Se riscontri problemi come disallineamenti dei fori o difficoltà nell'installare alcuni componenti, verifica che le viti siano utilizzate correttamente e regola la tensione delle viti.

ES: Antes de la instalación, coloque los tornillos en los agujeros y apriéte los, pero no al 100%; apretar al 70% - 80% es suficiente. Finalmente, después de haber instalado todos los tornillos, apriete todos los tornillos al 100%. Si se encuentra con problemas como desalineación de los agujeros o dificultad para instalar ciertas piezas, verifique que los tornillos se estén utilizando correctamente y ajuste la tensión de los tornillos.

NL: Voordat u begint met de installatie, plaatst u de schroeven in de gaten en draait u ze aan, maar draai ze niet volledig aan; 70% tot 80% is voldoende. Draai uiteindelijk, nadat alle schroeven zijn geplaatst, alle schroeven volledig aan. Als u problemen ondervindt, zoals niet uitgelijnde gaten of onderdelen die niet kunnen worden geïnstalleerd, controleer dan of de schroeven correct zijn gebruikt en pas de spanning van de schroeven aan.

SE: Innan installation, sätt i skruvarna i hålen och dra åt dem, men dra inte åt dem helt; 70% till 80% är tillräckligt. Slutligen, när alla skruvar är installerade, dra åt alla skruvar helt. Om du stöter på problem, som att hålen inte kan justeras eller vissa delar inte kan installeras, kontrollera om skruvarna används korrekt och justera skruvarnas åtdragning.

PL: Przed instalacją wstaw śruby w otwory i dokręć je, ale nie dokręcaj ich na 100%; 70% do 80% wystarczy. Na koniec, po zainstalowaniu wszystkich śrub, dokręć wszystkie śruby do 100%. Jeśli napotkasz problemy, takie jak niedopasowane otwory lub części, które nie mogą być zainstalowane, sprawdź, czy śruby są używane prawidłowo i dostosuj ich dokręcenie.

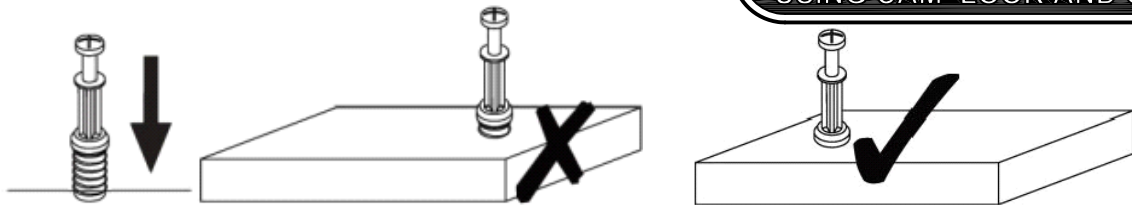

EN_QUICKFIT: Tighten quickfit until shoulder is flush with panel. Do not overtighten or undertighten.

FR_RACCORD RAPIDE: Faites serrer le raccord rapide jusqu'à ce que l'épaulement soit parfaitement encastré dans le panneau. Il ne faut ni trop serrer ni insuffisamment serrer.

ES_QUICKFIT: Apriete quickfit hasta que el hombro se descargue con el panel. NO lo sobreapriete ni lo apriete poco.

DE_QUICKFIT: Ziehen Sie den Quickfit fest, bis die Schulter mit der Platte bündig ist. Bitte nicht zu fest oder zu schwach anziehen.

IT_MONTAGGIO RAPIDO: Stringere il montaggio rapido fino a quando la spalla è a filo con il pannello, non stringere troppo o troppo poco.

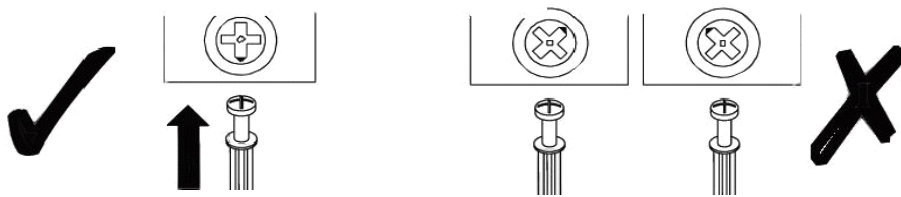

EN_CAM LOCK: When fitting cam lock, ensure starting position is correct before you insert connecting quickfit.

FR_SERRURE BATTEUSE: Avant d'insérer la serrure batteuse, veillez à la bonne orientation avant d'insérer le raccord rapide.

ES_CIERRE DE LA CÁMARA: Cuando instale el cierre de la cámara, asegúrese de que la posición de inicio es correcta antes de que inserte el quickfit conector.

DE_CAM-LOCK: Achten Sie bei der Montage des Cam-Locks auf die richtige Ausgangsposition, bevor Sie den Quickfit einsetzen.

IT_BLOCCAGGIO A CAMMA: Quando si monta il bloccaggio a camma, assicurarsi che la posizione iniziale sia corretta prima di inserire il montaggio rapido di collegamento.

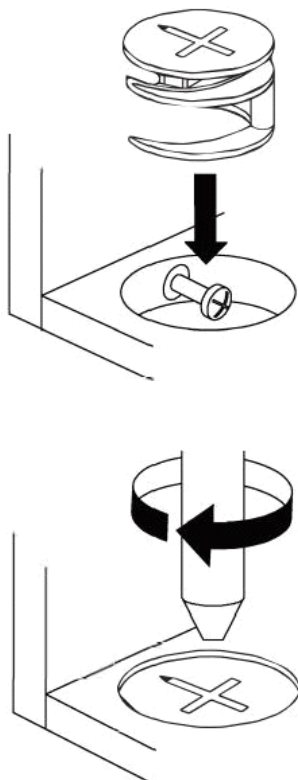

EN_Quickfit head should be in the centre of the cam lock when the two panels are joined.

Cam lock should be inserted before quickfit.

FR_Lorsque les deux panneaux sont assemblés, la tête du raccord rapide doit reposer au centre de la serrure batteuse. Il faut insérer la serrure batteuse avant le raccord rapide.

ES_El cabezal del quickfit debe estar en el centro del cierre de la cámara cuando se unan los dos paneles.

Se debe insertar el cierre de la cámara antes que el quickfit.

DE_Der Quickfit-Kopf sollte sich in der Mitte des Cam-Locks befinden, wenn die beiden Platten zusammengefügt sind.

Der Cam-Lock sollte vor dem Quickfit eingesetzt werden.

IT_La testa del montaggio rapido deve trovarsi al centro del bloccaggio a camma quando i due pannelli sono uniti.

Il Bloccaggio a Camma deve essere inserito prima del montaggio rapido.

EN_Turn cam lock clockwise to tighten.

FR_Faites tourner la serrure batteuse dans le sens des aiguilles d'une montre pour la resserrer.

ES_Gire el cierre de la cámara en sentido horario para apretarlo.

DE_Drehen Sie den Cam-Lock im Uhrzeigersinn, um ihn festzuziehen.

IT_Ruotare il bloccaggio a camma in senso orario per stringere.

Parts list

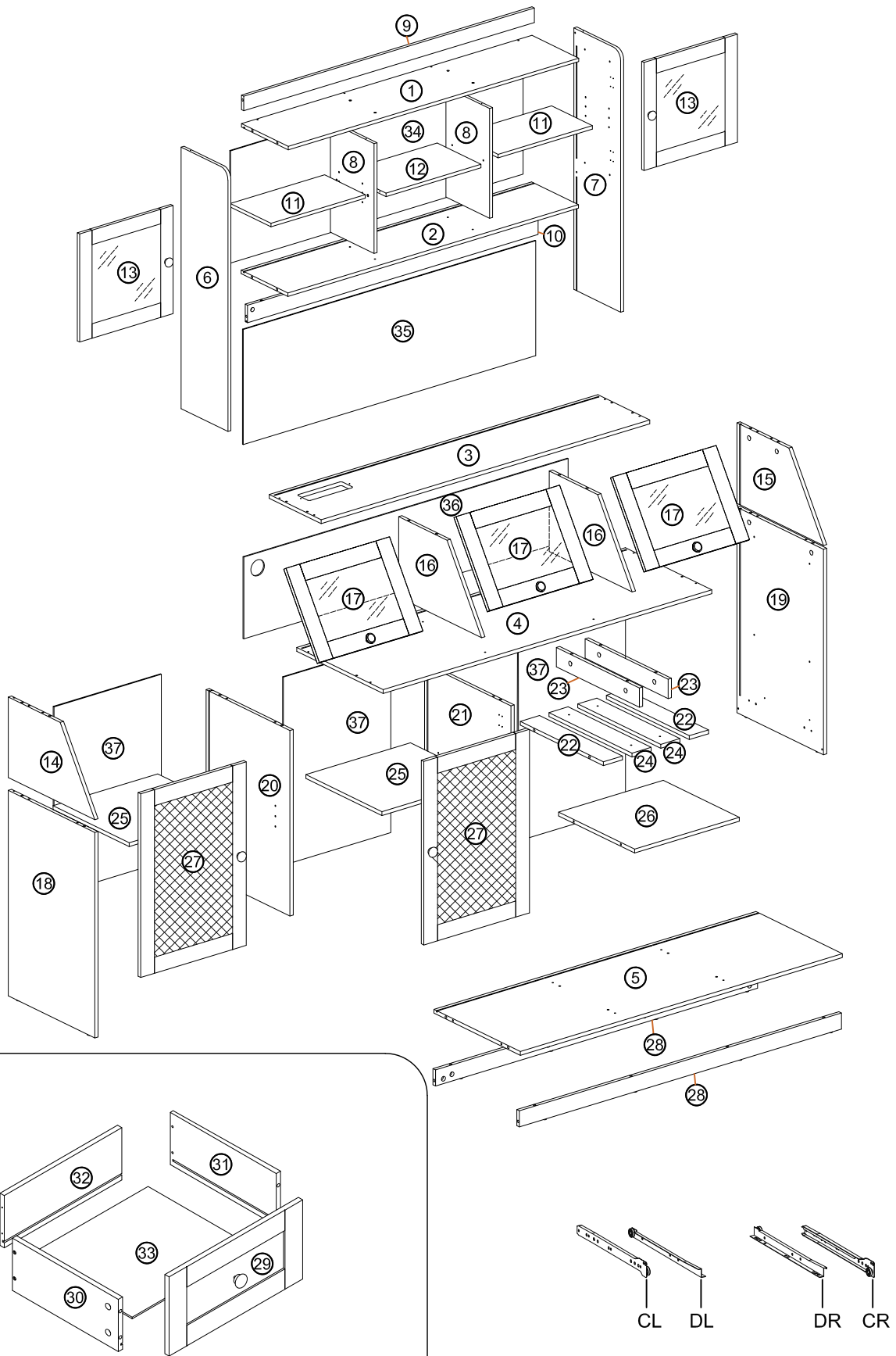



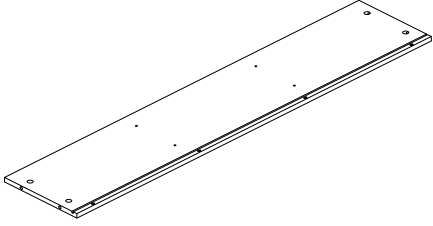
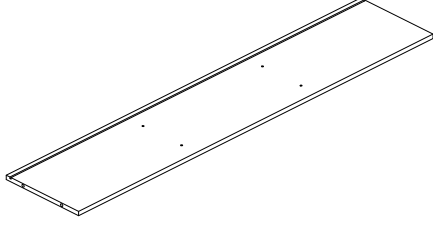
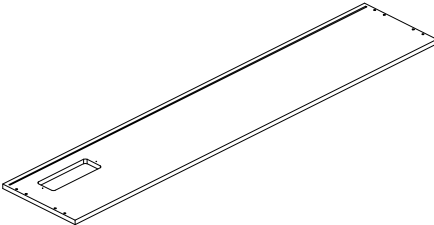
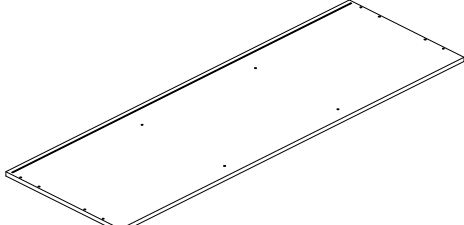
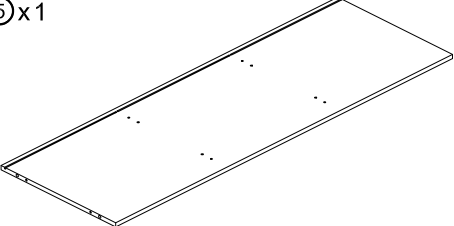
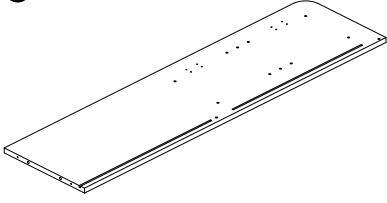
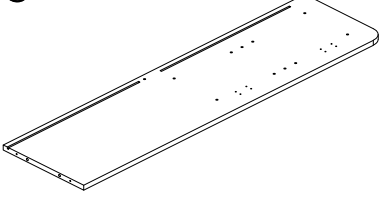
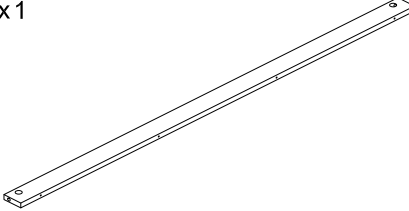
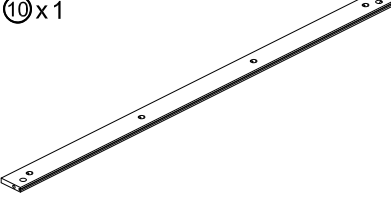
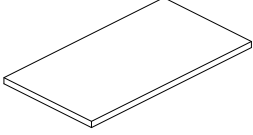
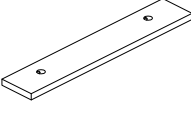
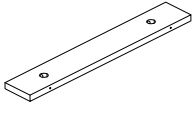
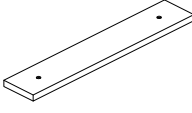
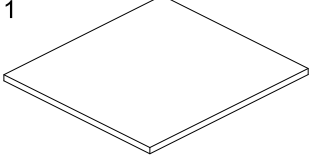
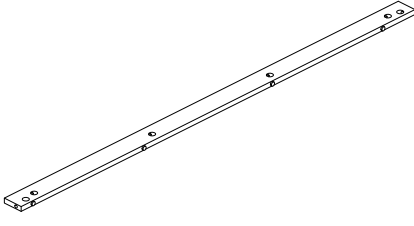
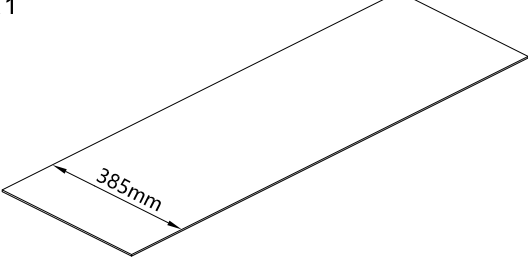
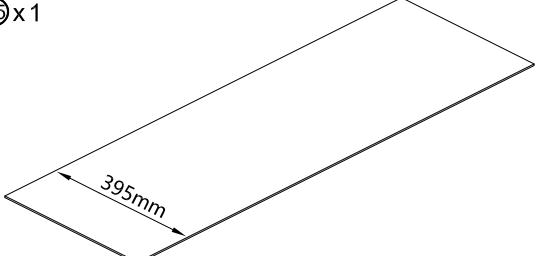
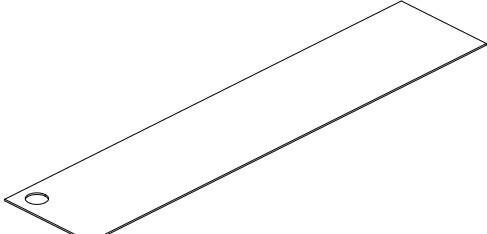
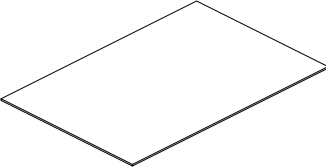



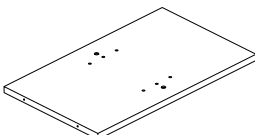
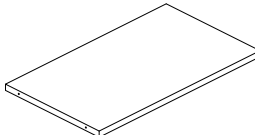
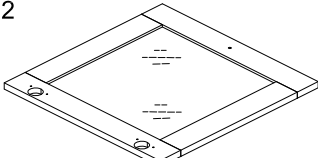
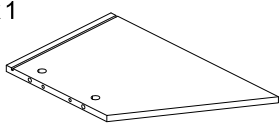
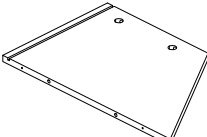
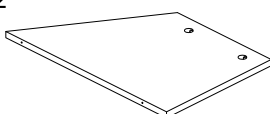
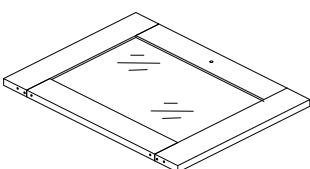
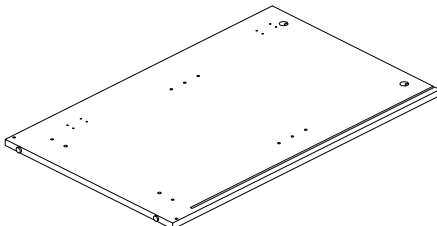
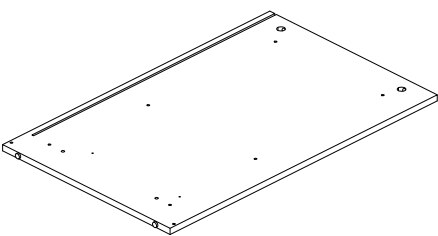
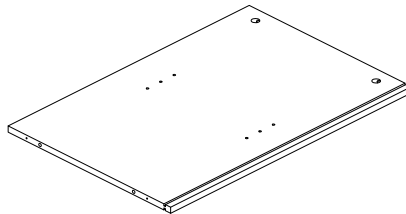
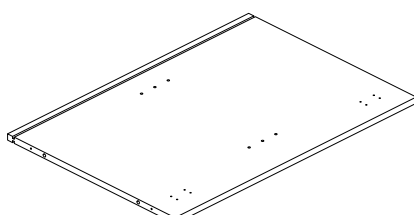
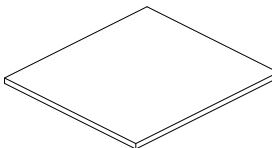
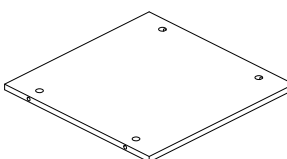
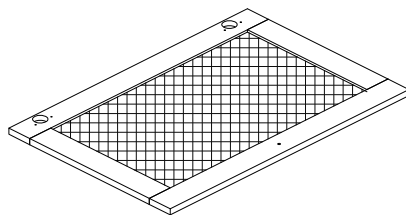
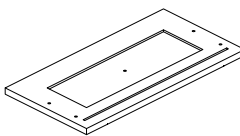
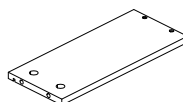
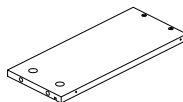
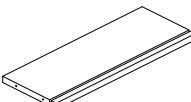
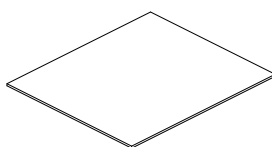
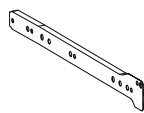
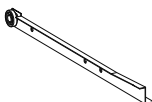
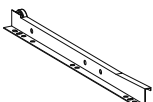
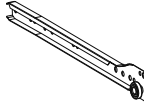











N620P429906

① x1 	② x1 		
③ x1 	④ x1 		
⑤ x1 	⑥ x1 	⑦ x1 	
⑨ x1 	⑩ x1 	⑪ x2 	
⑫ x2 	⑬ x2 	⑭ x2 	⑮ x1 
⑯ x2 	⑳ x1 		
㉑ x1 	㉒ x1 		
㉓ x3 			

N620P429907

<p>⑧x2</p> 	<p>⑫x1</p> 	<p>⑬x2</p> 	
<p>⑭x1</p> 	<p>⑮x1</p> 	<p>⑯x2</p> 	
<p>⑰x3</p> 	<p>⑱x1</p> 		
<p>⑲x1</p> 	<p>⑳x1</p> 		
<p>㉑x1</p> 	<p>㉕x1</p> 	<p>㉖x1</p> 	
<p>㉗x2</p> 	<p>㉙x1</p> 	<p>㉚x1</p> 	
<p>㉛x1</p> 	<p>㉜x1</p> 	<p>㉞x1</p> 	<p>CLx1</p> 
<p>DLx1</p> 	<p>DRx1</p> 	<p>CRx1</p> 	

Hardware N620P429907

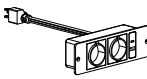
A	x64	B	x64	C	x28	D	x116	E	x40	F	x2
										F1  Φ 4x45mm	
Φ 6x36mm		Φ 15mm		Φ 6x30mm		Φ 3.5*12mm		Φ 4x35mm		F2  Φ 8x35mm	
G	x2	H	x22	J	x16	K	x8	M	x6	L	x1
											
Φ 4x14mm		15x10mm		5x19mm						M4x6mm	
N	x7	P	x2	Q	x8	R	x1	S	x1		
						T1  T2 					
M4x15mm						1100mm					

(DE) Bitte beachten Sie, dass die Formen der Schrauben D und E ähnlich sind. Bitte installieren Sie entsprechend der Anleitung und unterscheiden Sie sie

(UK) Please note that the shapes of screws D and E are similar. Please install according to the instructions and distinguish them!

(FR) Notez que les vis D et E ont des formes similaires. Veuillez les installer en suivant les instructions pour les séparer!

(IT) Si prega di notare che le forme delle viti D e E sono simili. Si prega di installarle seguendo le istruzioni e di distinguerle!

(ES) Por favor, tenga en cuenta que las formas de los tornillos D y E son similares. Por favor, instálelos de acuerdo con las instrucciones y distíngalos.

(NL) Let op, de vormen van schroeven D en E zijn vergelijkbaar. Installeer volgens de instructies en maak onderscheid tussen ze!

(SE) Observera att formerna på skruvarna D och E är lika. Installera enligt anvisningarna och särskilj dem!

(PL) Zauważ, że kształty śrub D i E są podobne. Zainstaluj zgodnie z instrukcjami i rozróżnij je!

1

A	x4
Φ6x36mm	

K	x1

L	x1
M4x6MM	

2

E	x4
Φ4x35mm	

3

4

B	x4
Φ15mm	

5

D	x4
Φ3.5*12mm	

DL	x1

DR	x1

6

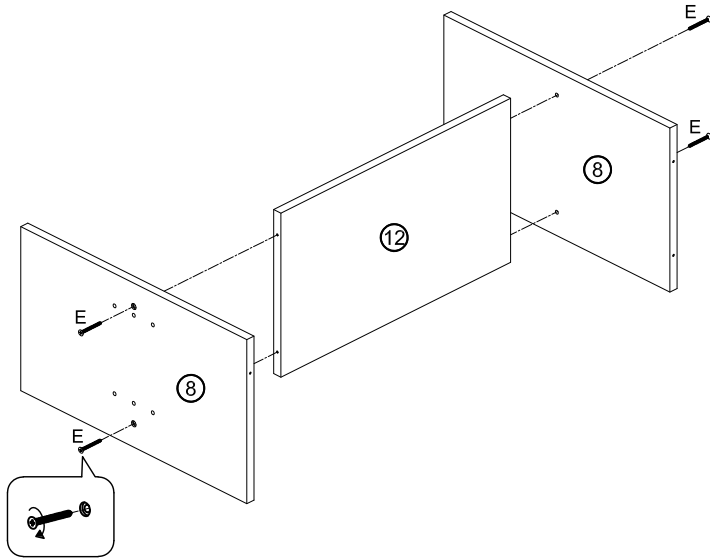

E	x4
	
Φ4x35mm	

7

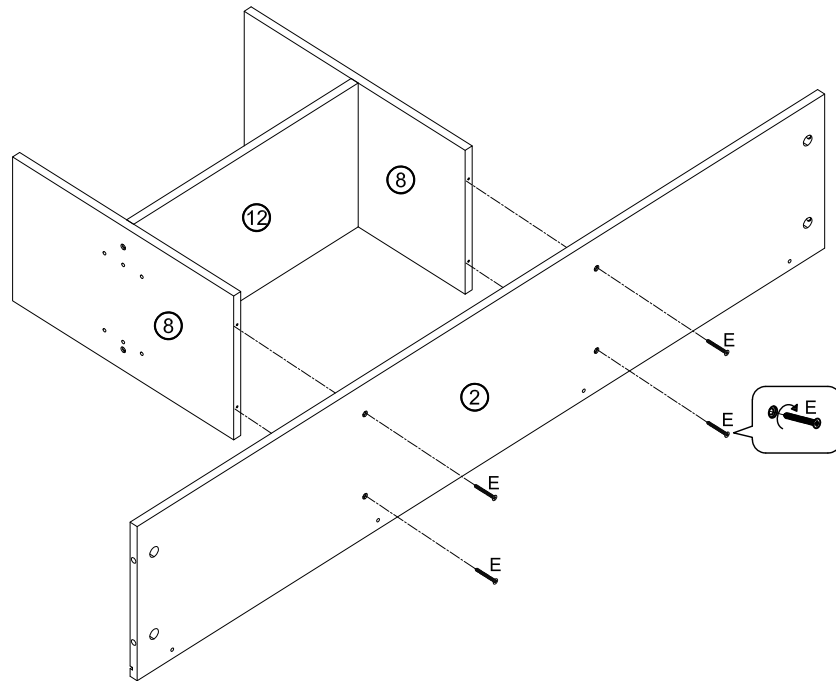

E	x4
	
Φ4x35mm	

8

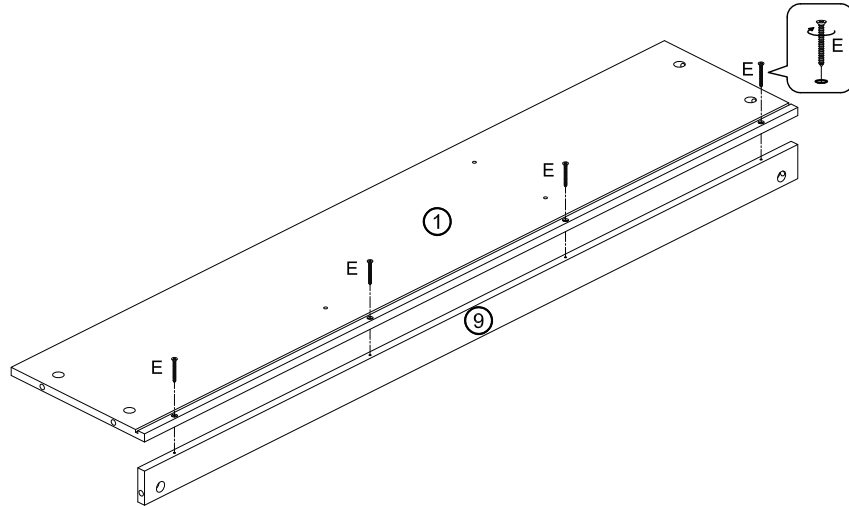

E	x4
	
Φ4x35mm	

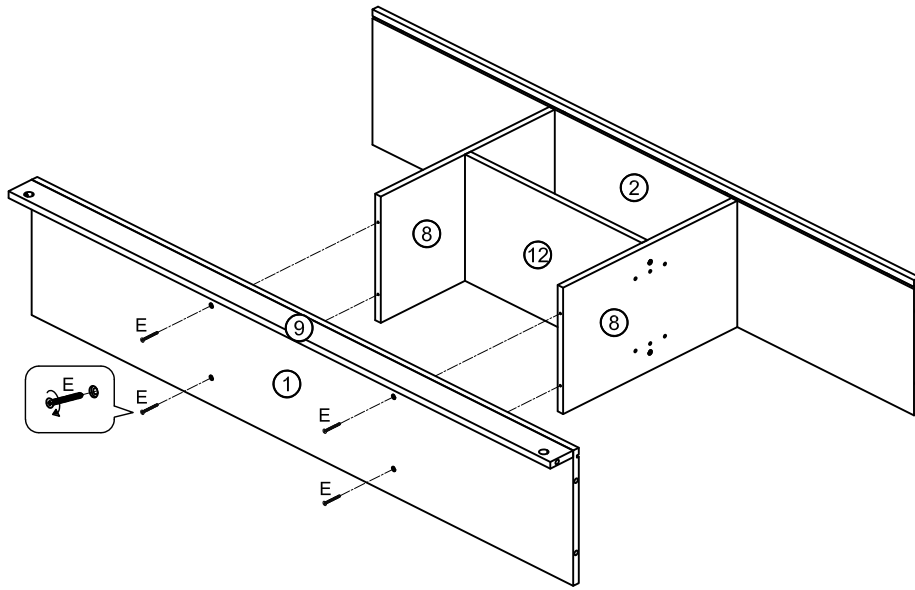

9

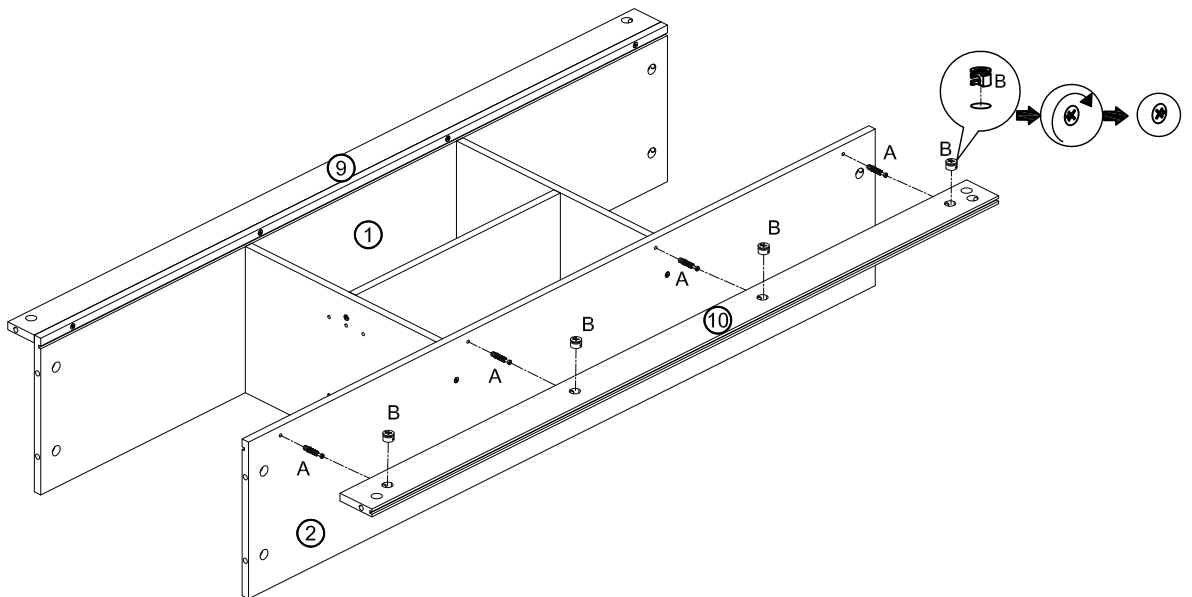

E	x4
	
Φ4x35mm	

10



A	x4	B	x4
			
Φ6x36mm		Φ15mm	

11

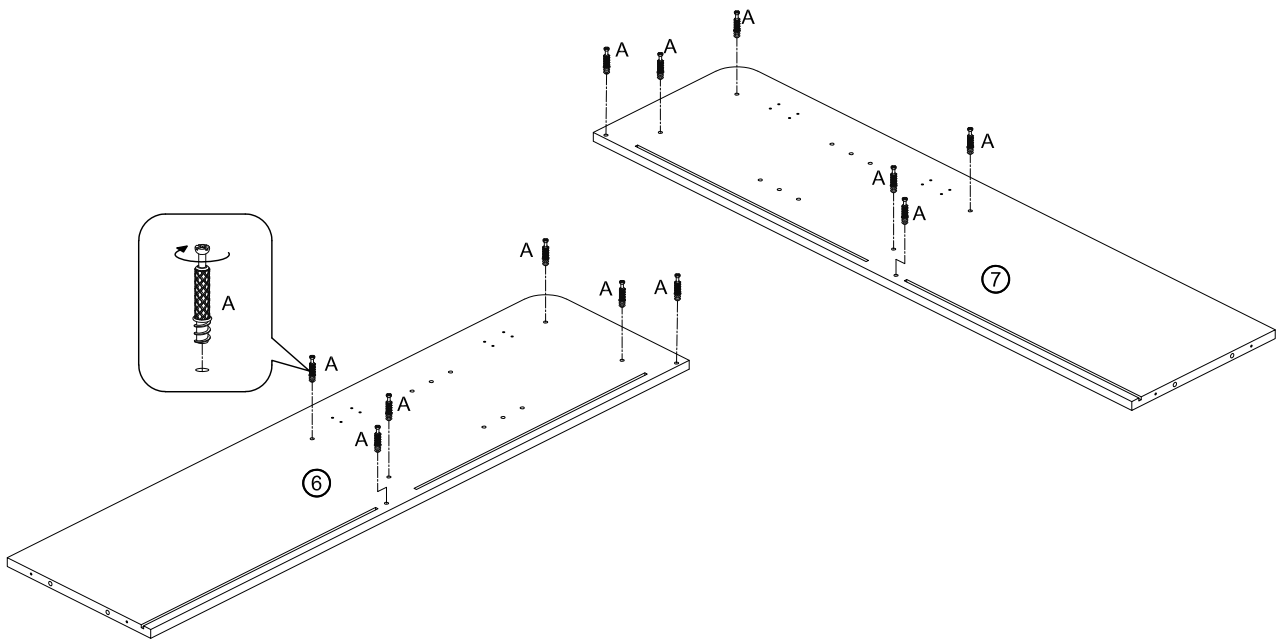

A	x 12
	
Φ6x36mm	

12

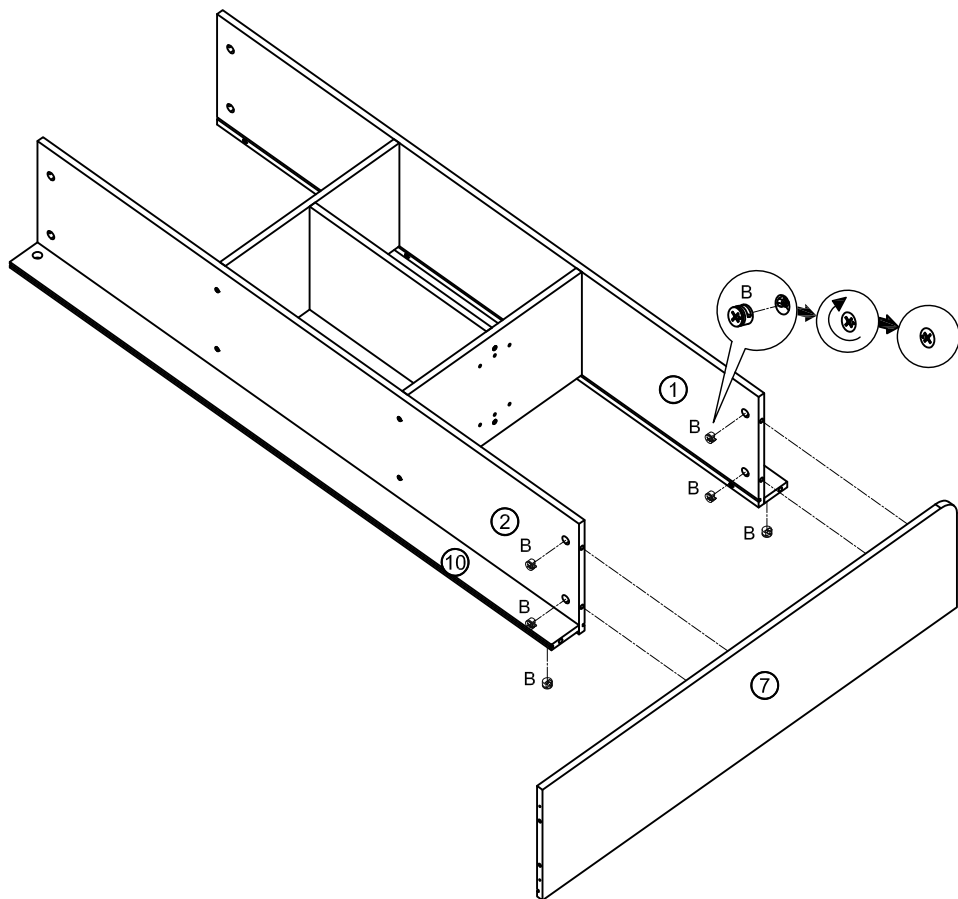

B	x 6
	
Φ15mm	

13

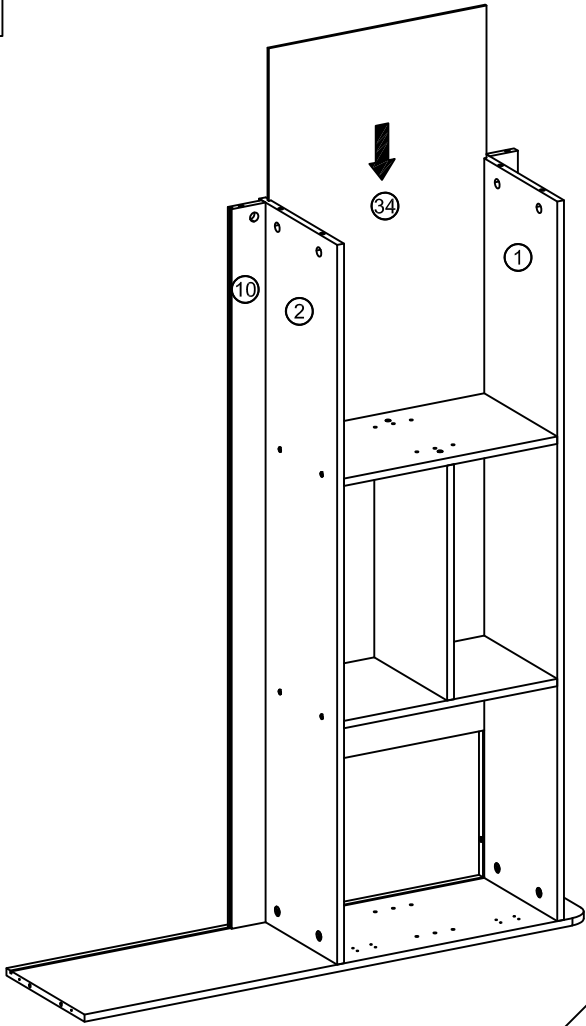

14

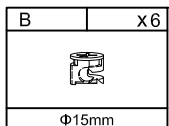
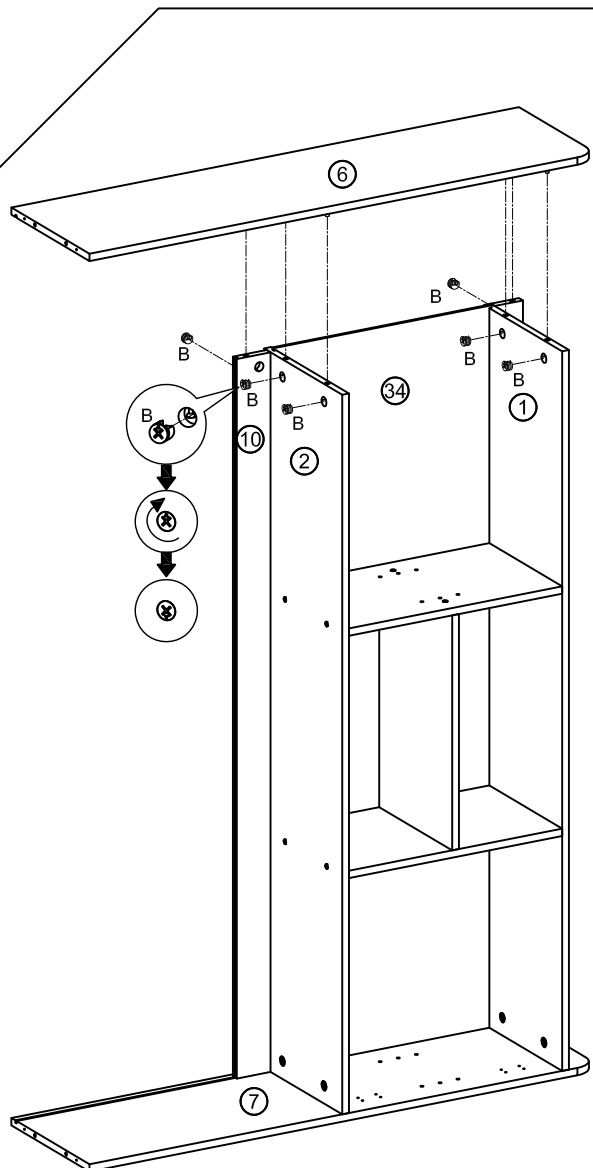

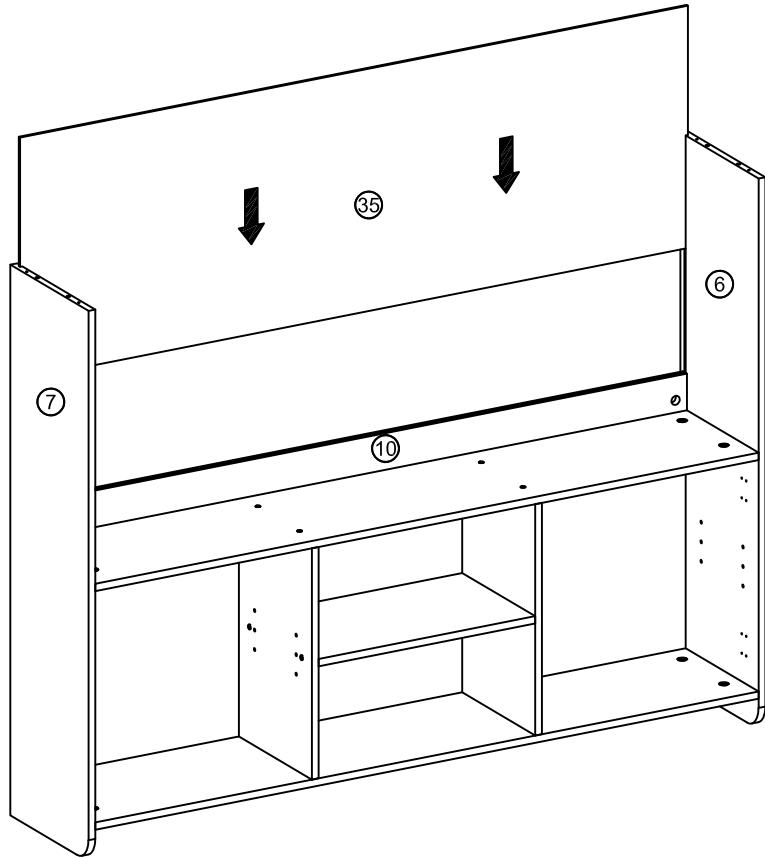

15



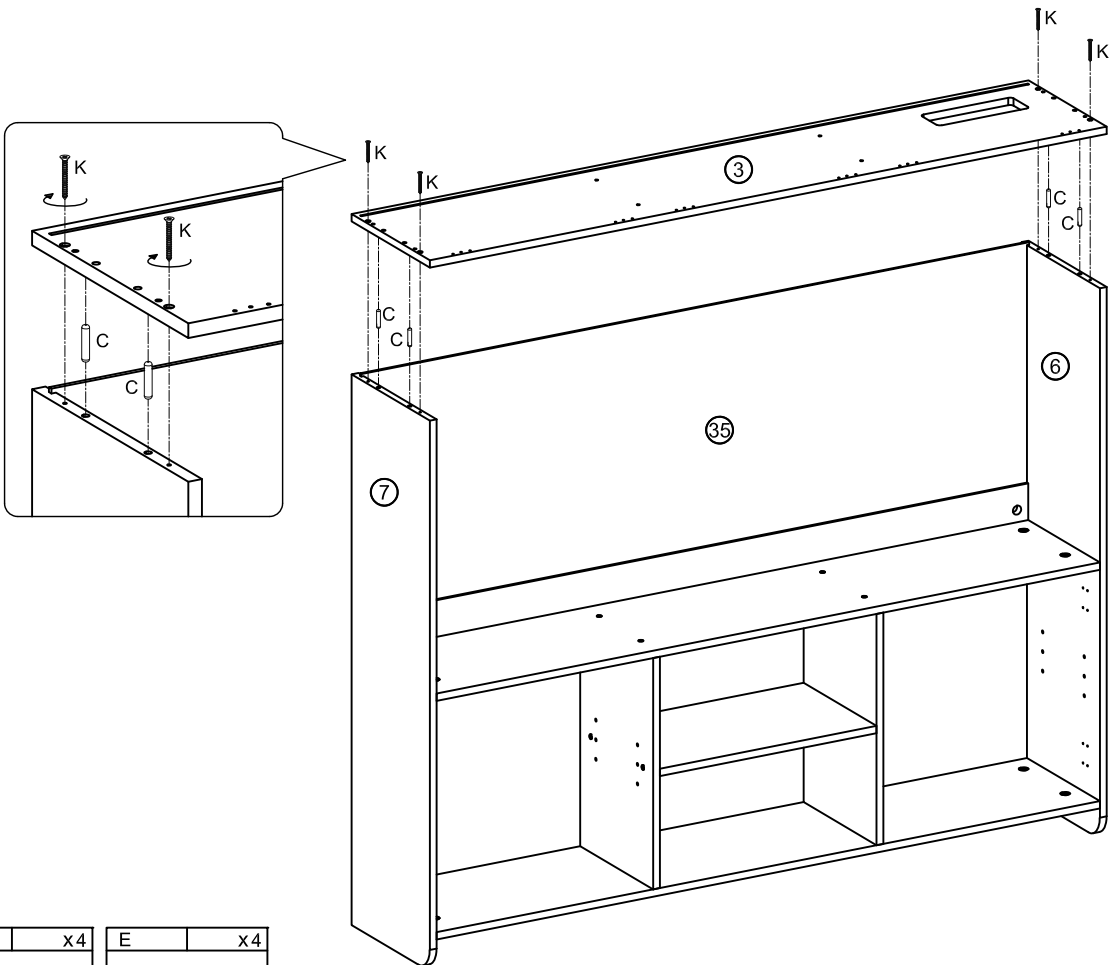



16

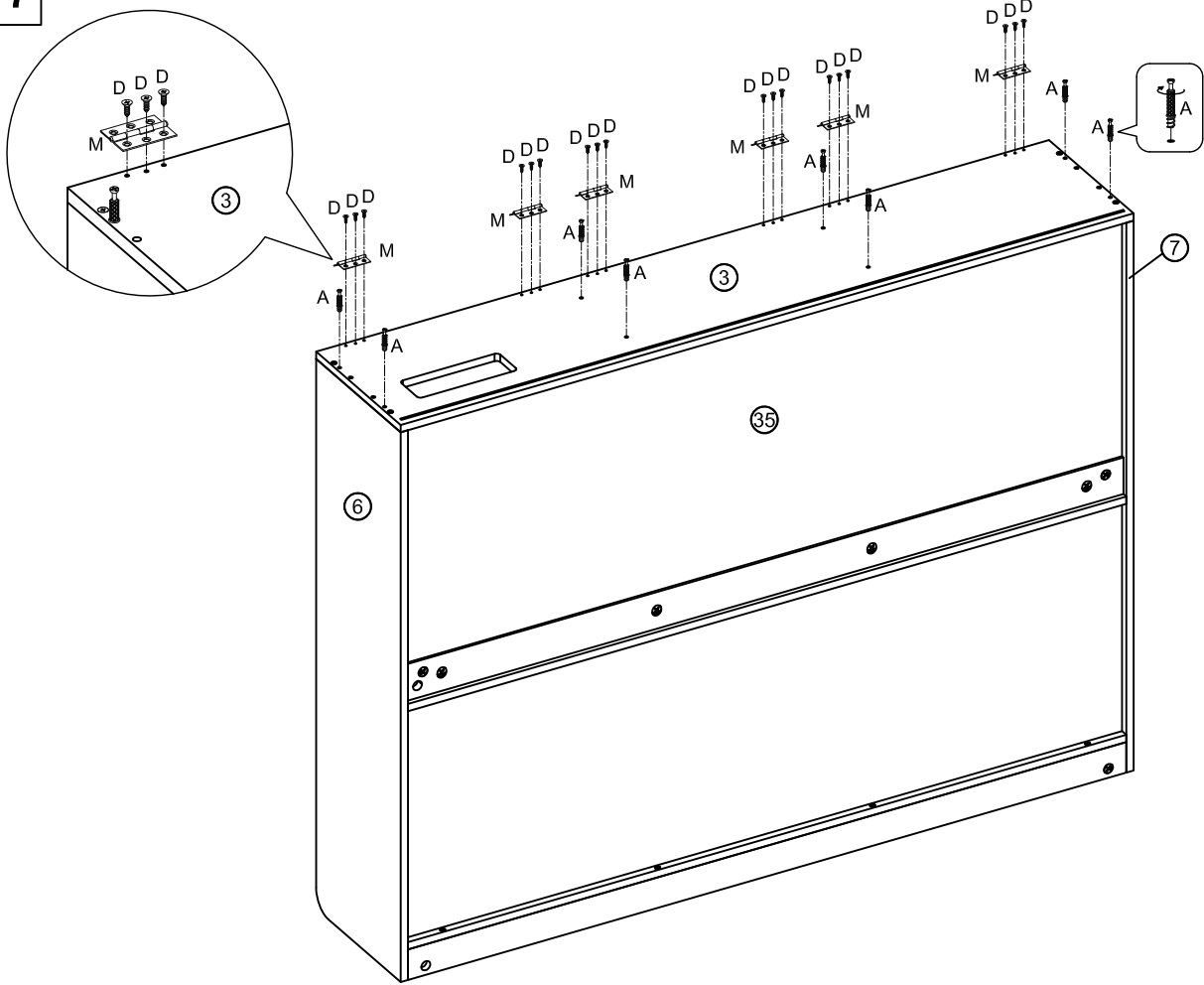

C	x4	E	x4
			
Φ6x30mm		Φ4x35mm	

17



A	x8	D	x18	M	x6
					
Φ6x36mm		Φ3.5*12mm			

18

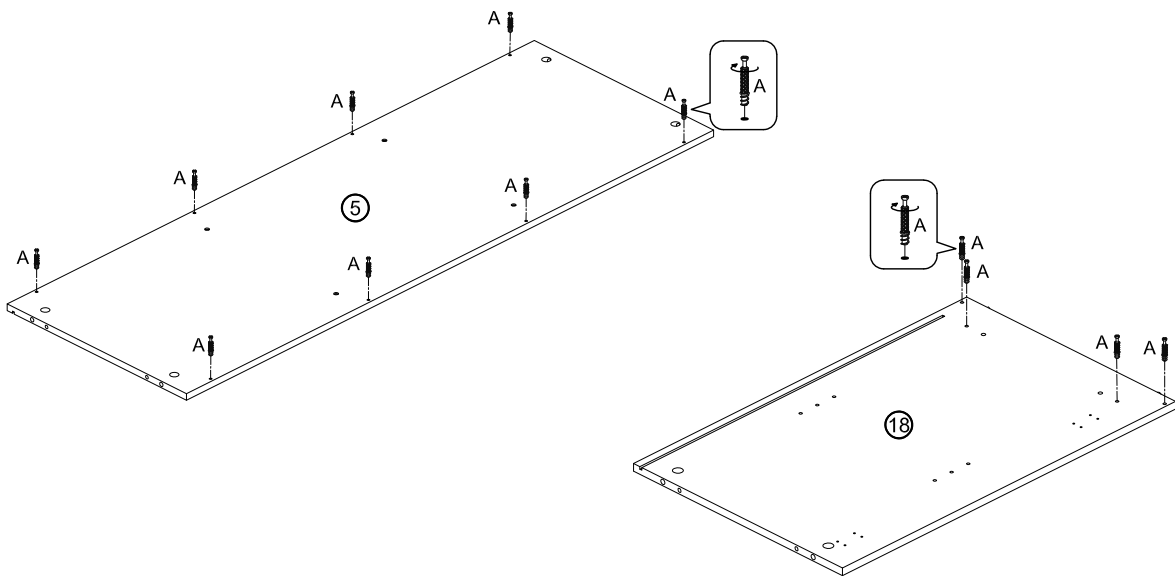

A	x12
	
Φ6x36mm	

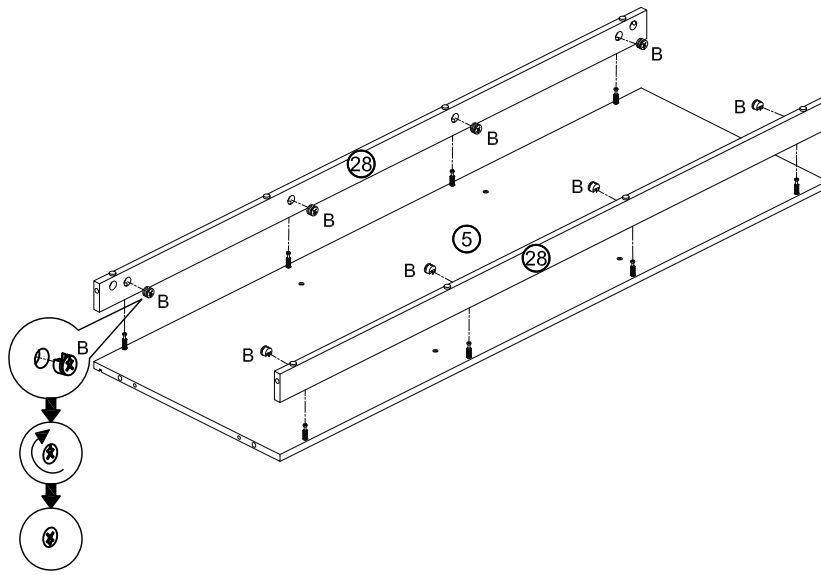

19



B	x8
	
Φ15mm	

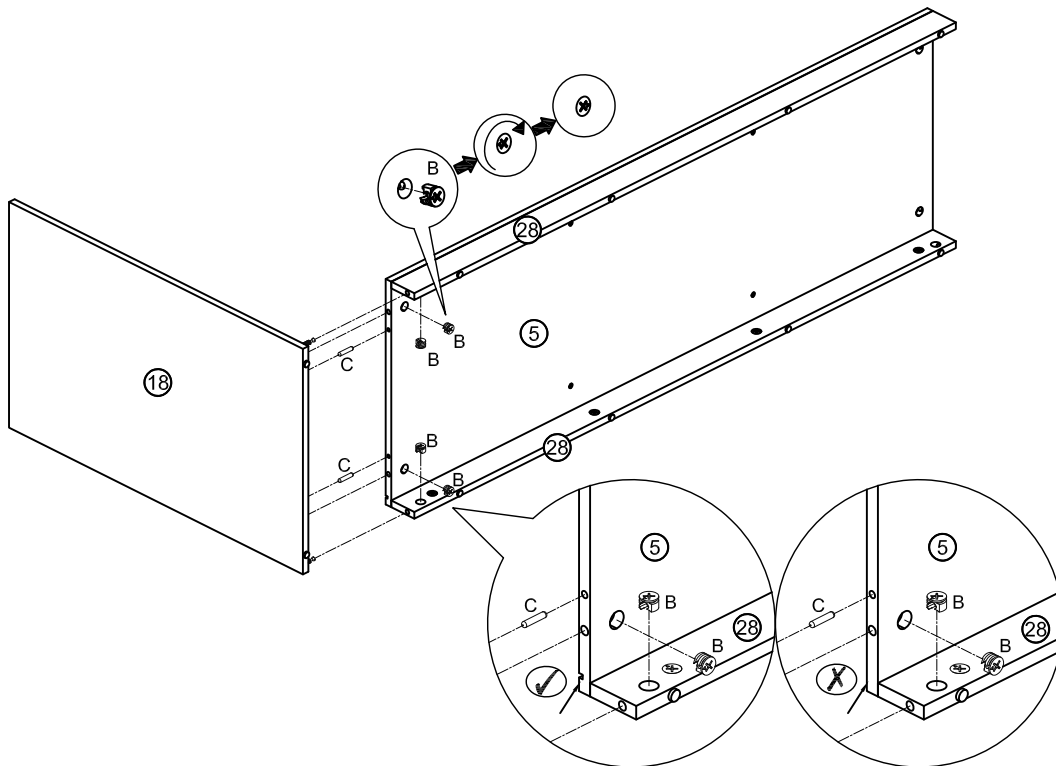

20



B	x4	C	x2
			
Φ15mm		Φ6x30mm	

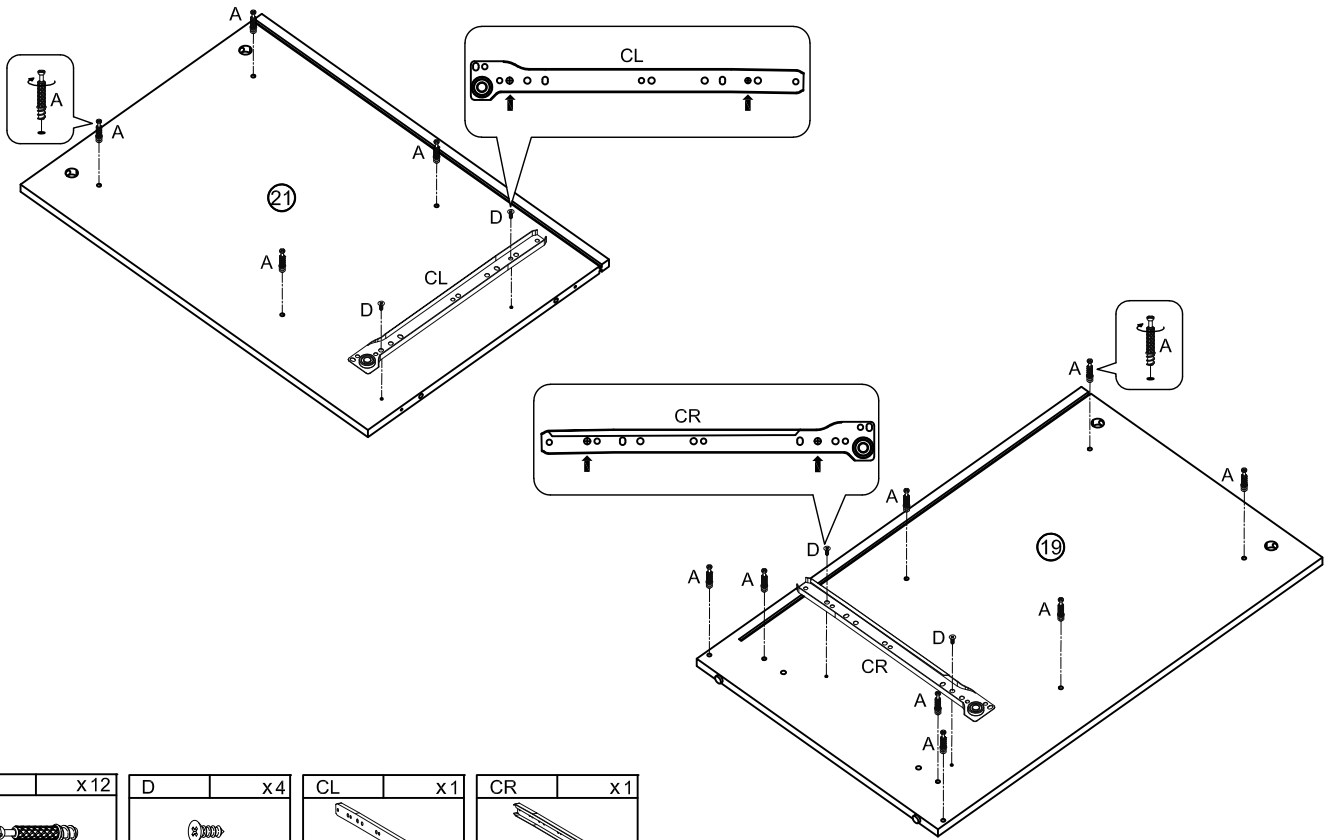

21

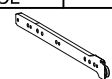
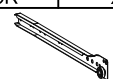

A	x12	D	x4	CL	x1	CR	x1
							
Φ6x36mm		Φ3.5*12mm					

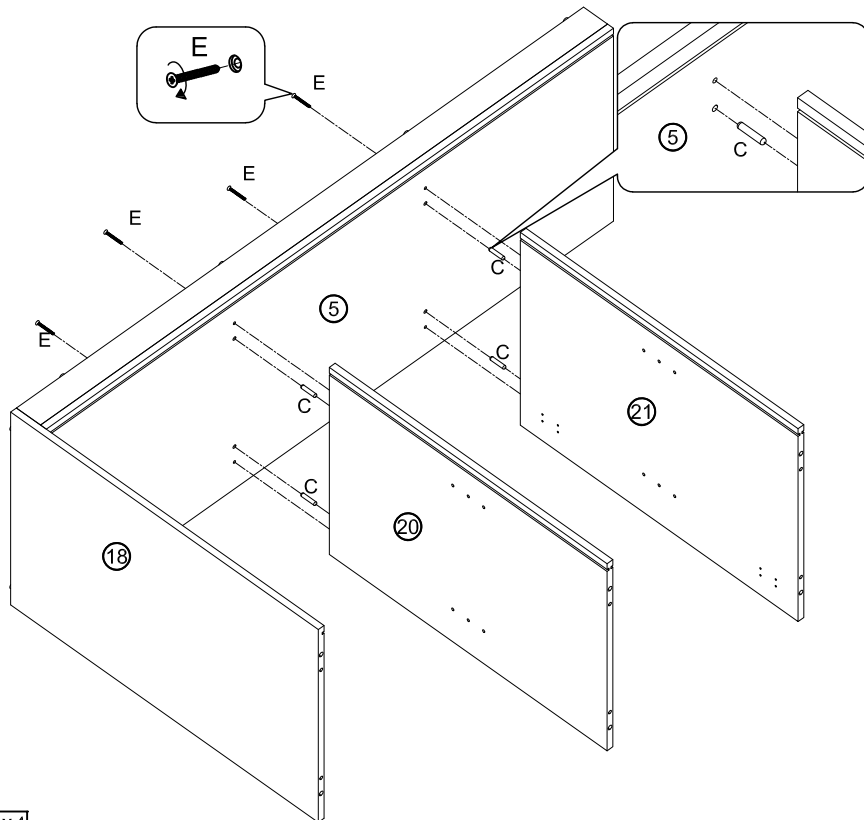
22



C	x4	E	x4
			
Φ6x30mm		Φ4x35mm	

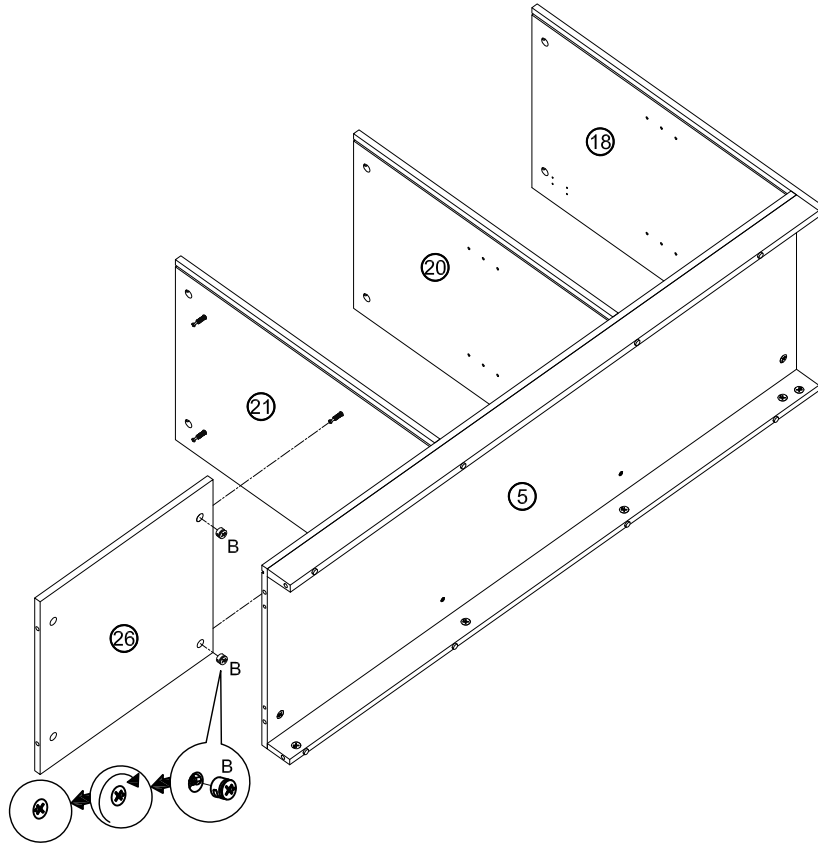

23

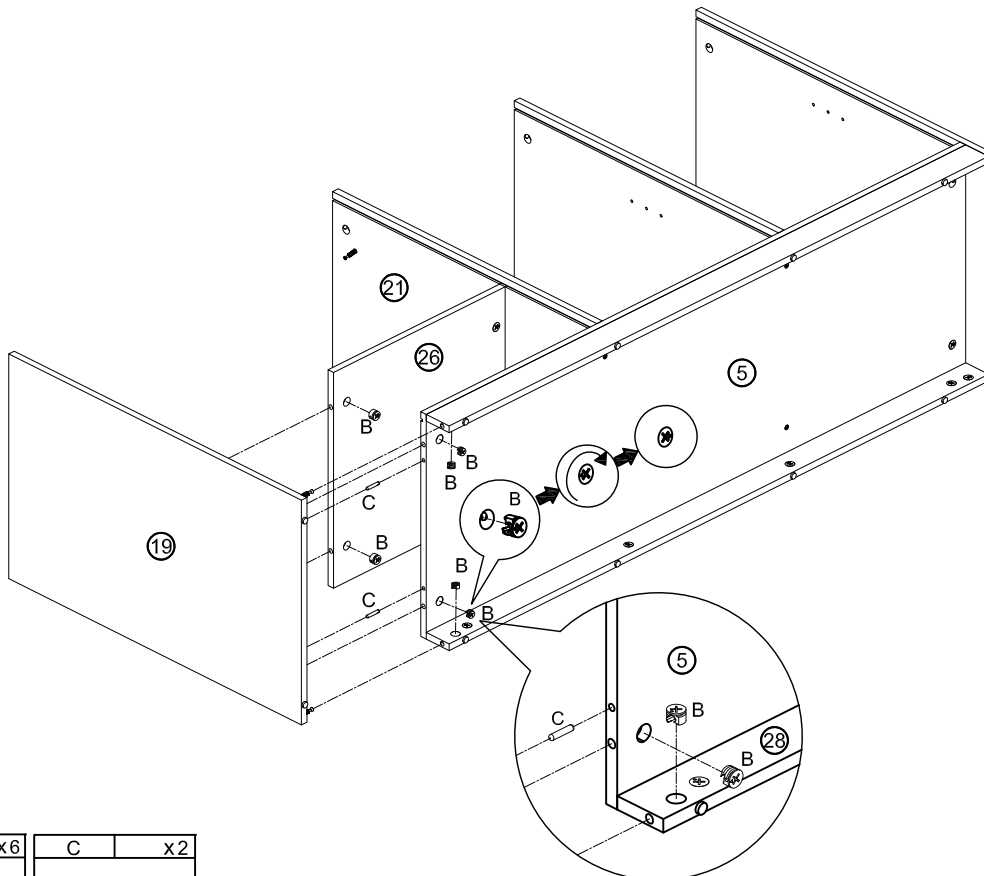

B	x2
	
Φ15mm	

24



B	x6	C	x2
			
Φ15mm		Φ6x30mm	

25

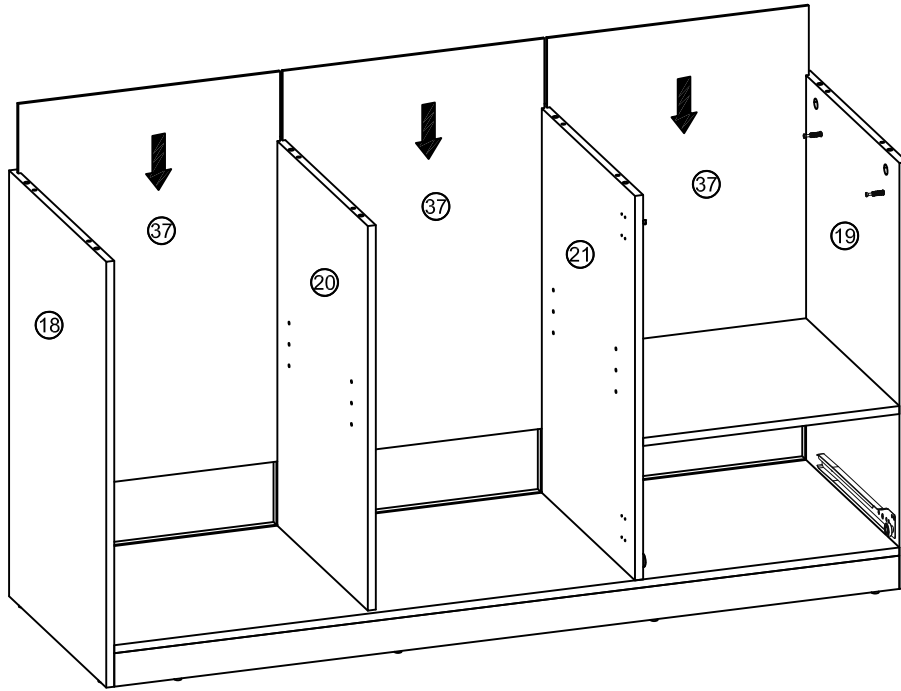

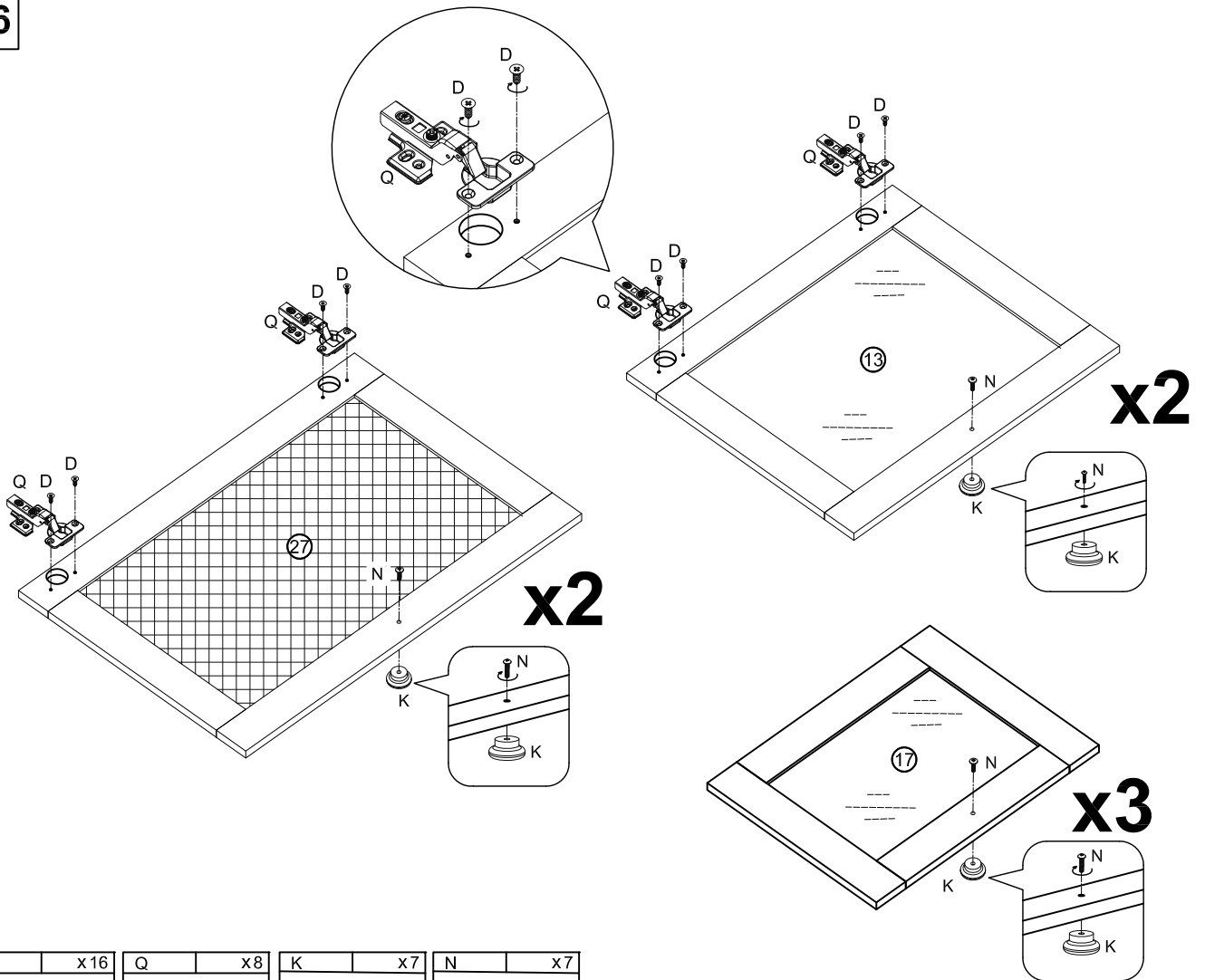

26

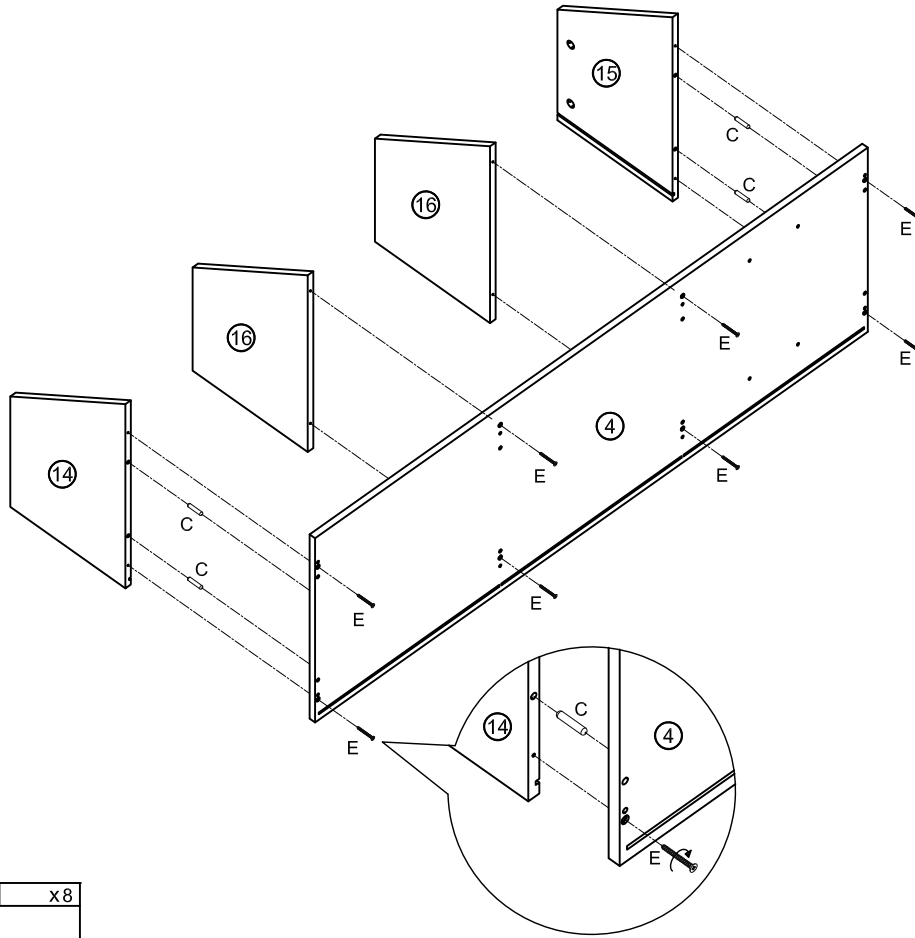

D	x16	Q	x8	K	x7	N	x7
Φ3.5*12mm						M4x15mm	

27



C	x4	E	x8
			
Φ6x30mm		Φ4x35mm	

28

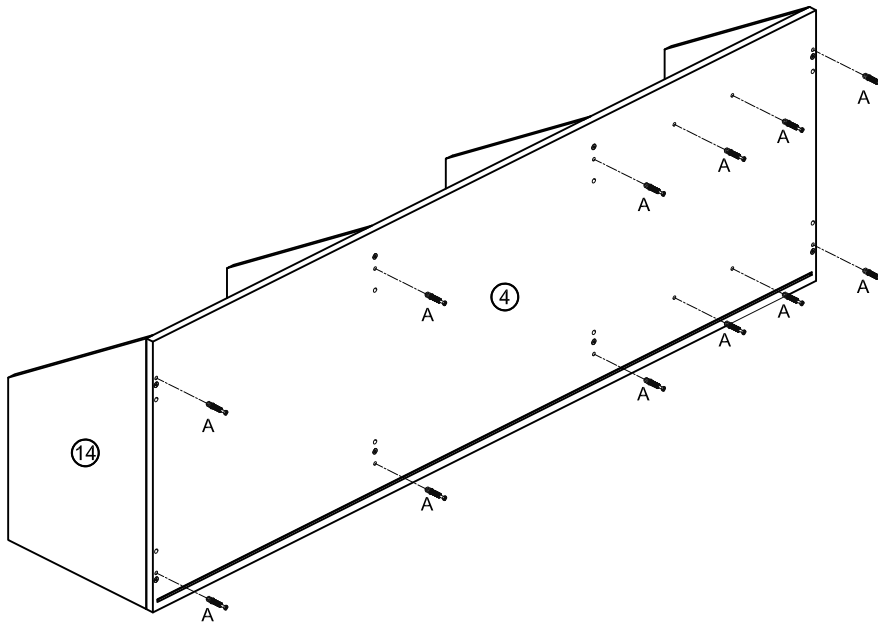

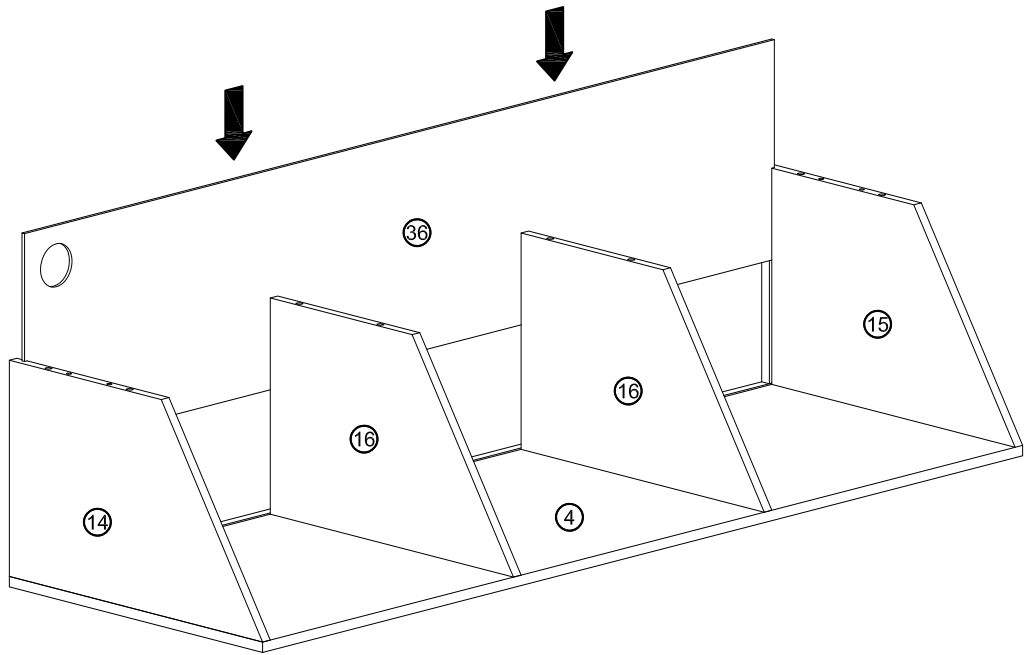

A	x12
	
Φ6x36mm	

29



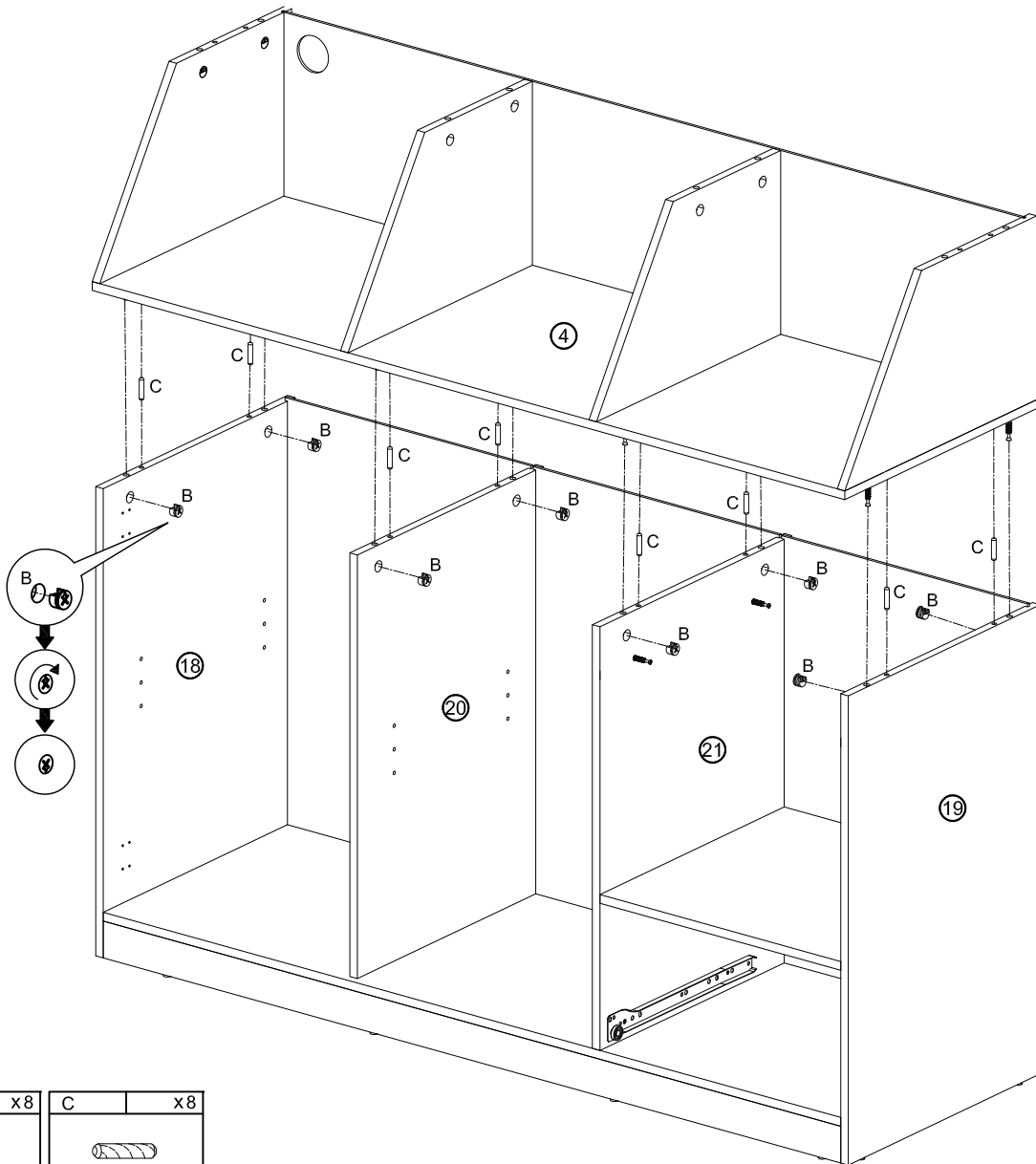

30

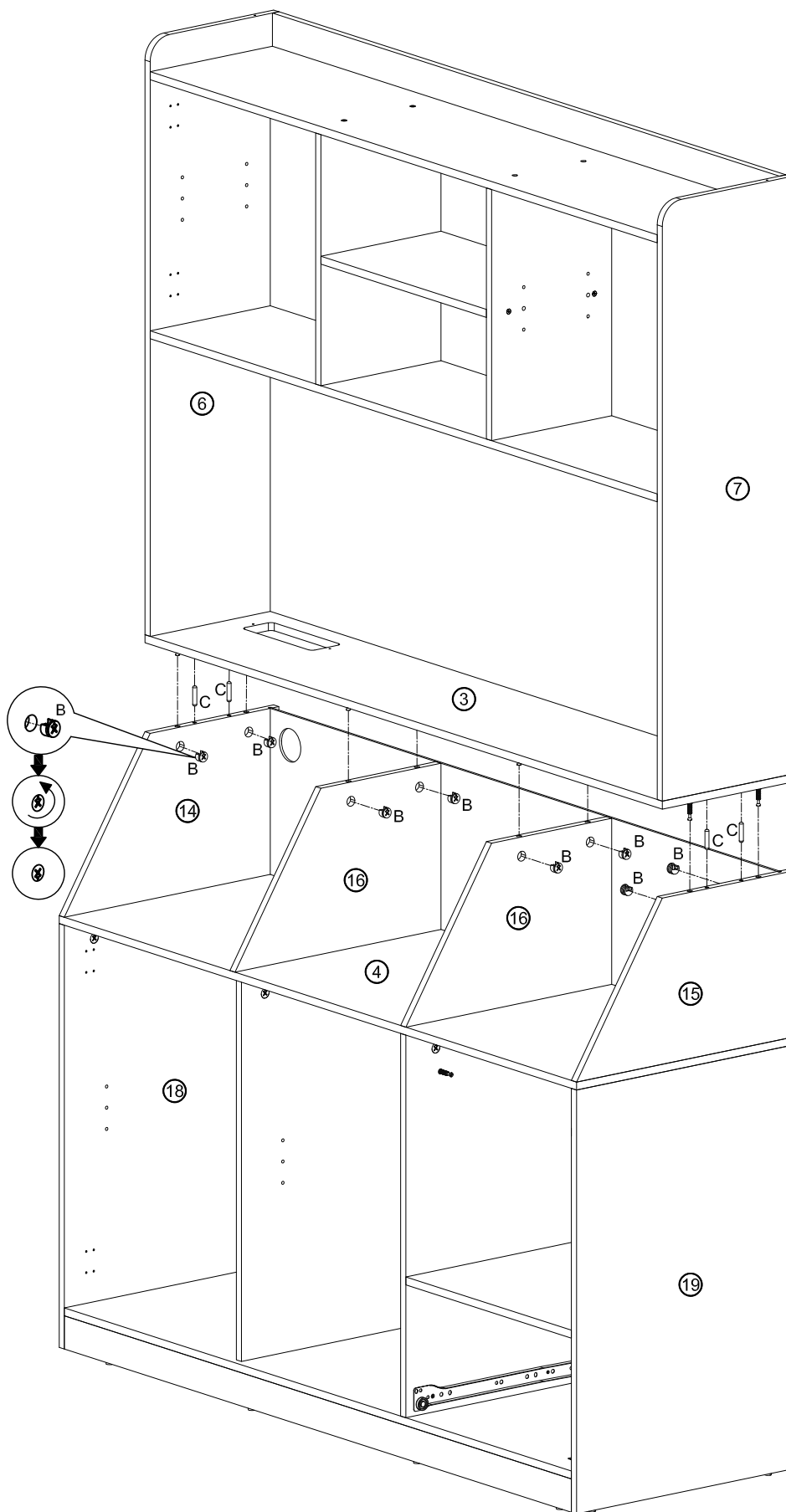

B	x8	C	x8
			
Φ15mm		Φ6x30mm	



B	x8	C	x4
			
Φ15mm		Φ6x30mm	

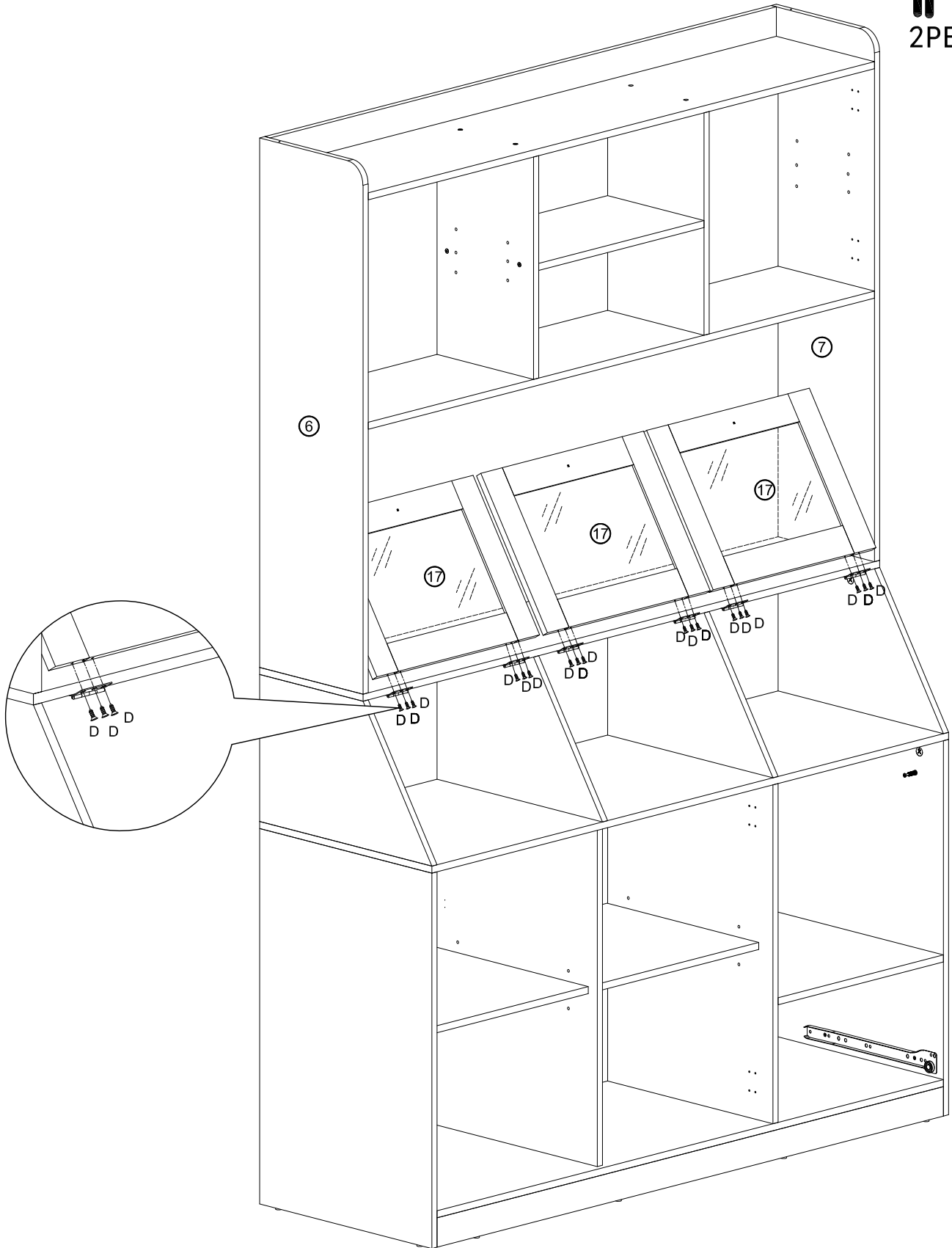

D	x18
	
Φ3.5*12mm	

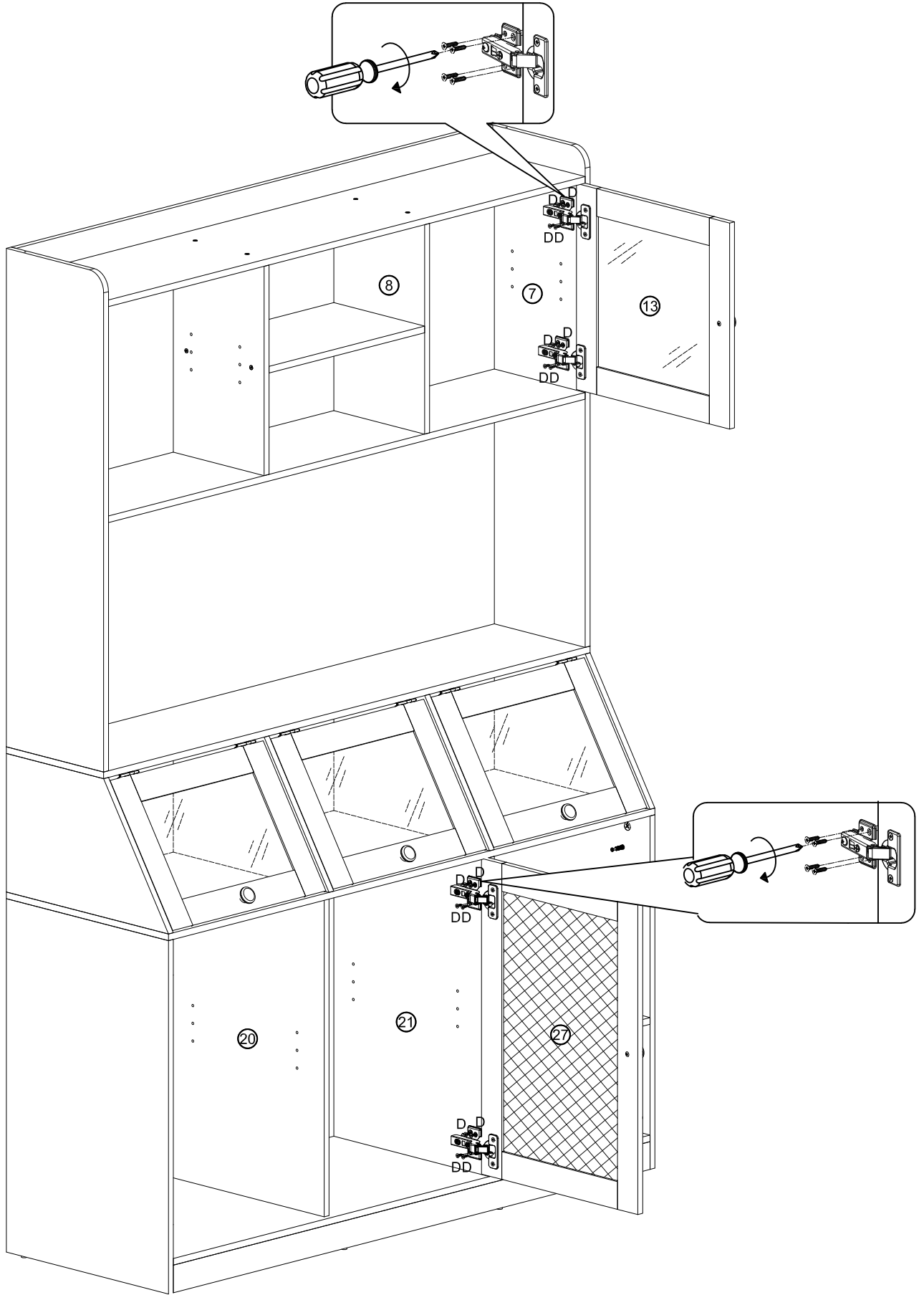

D	x16
	
$\Phi 3.5 \times 12\text{mm}$	

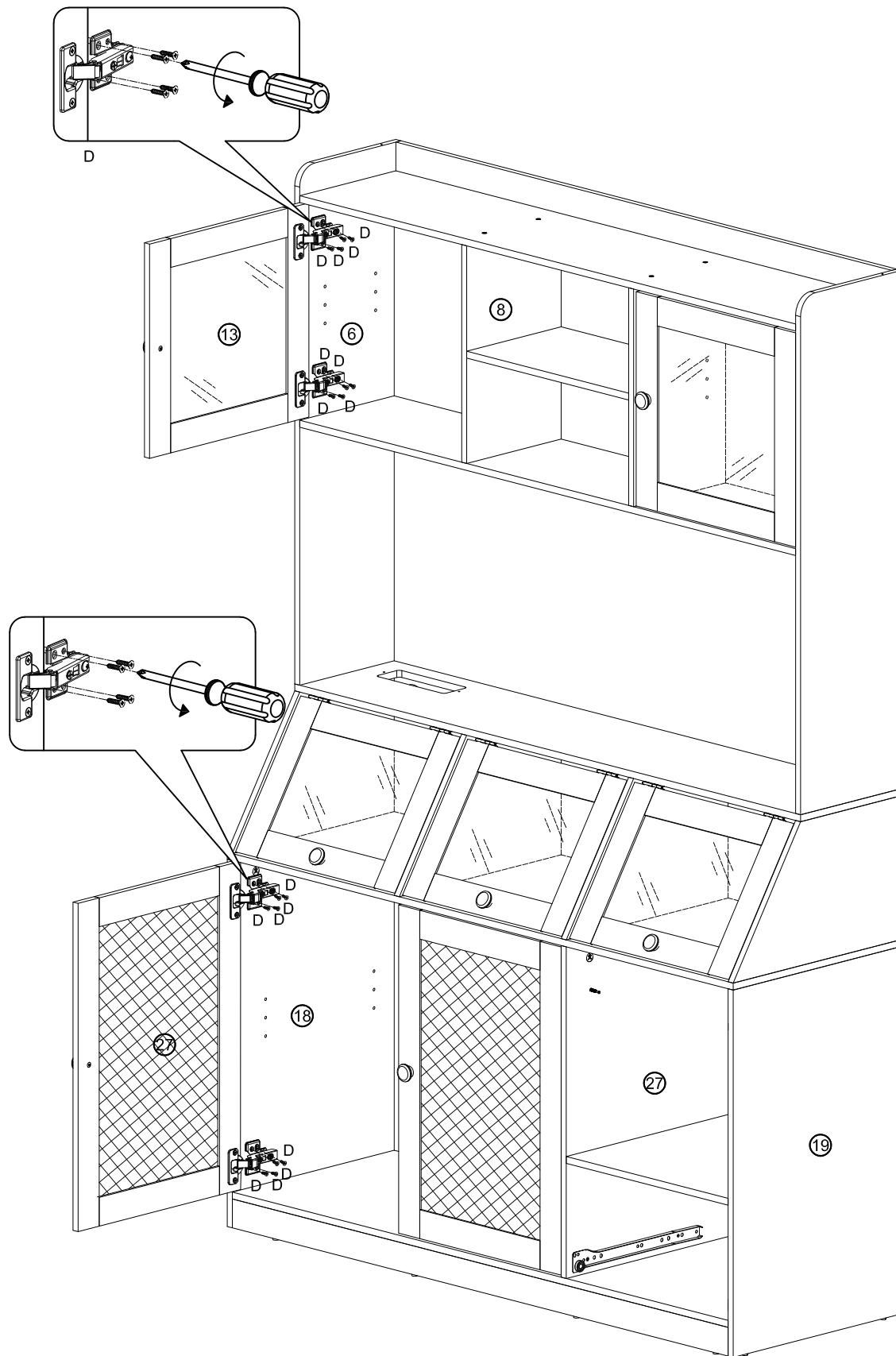

D	x16
	
Φ3.5*12mm	

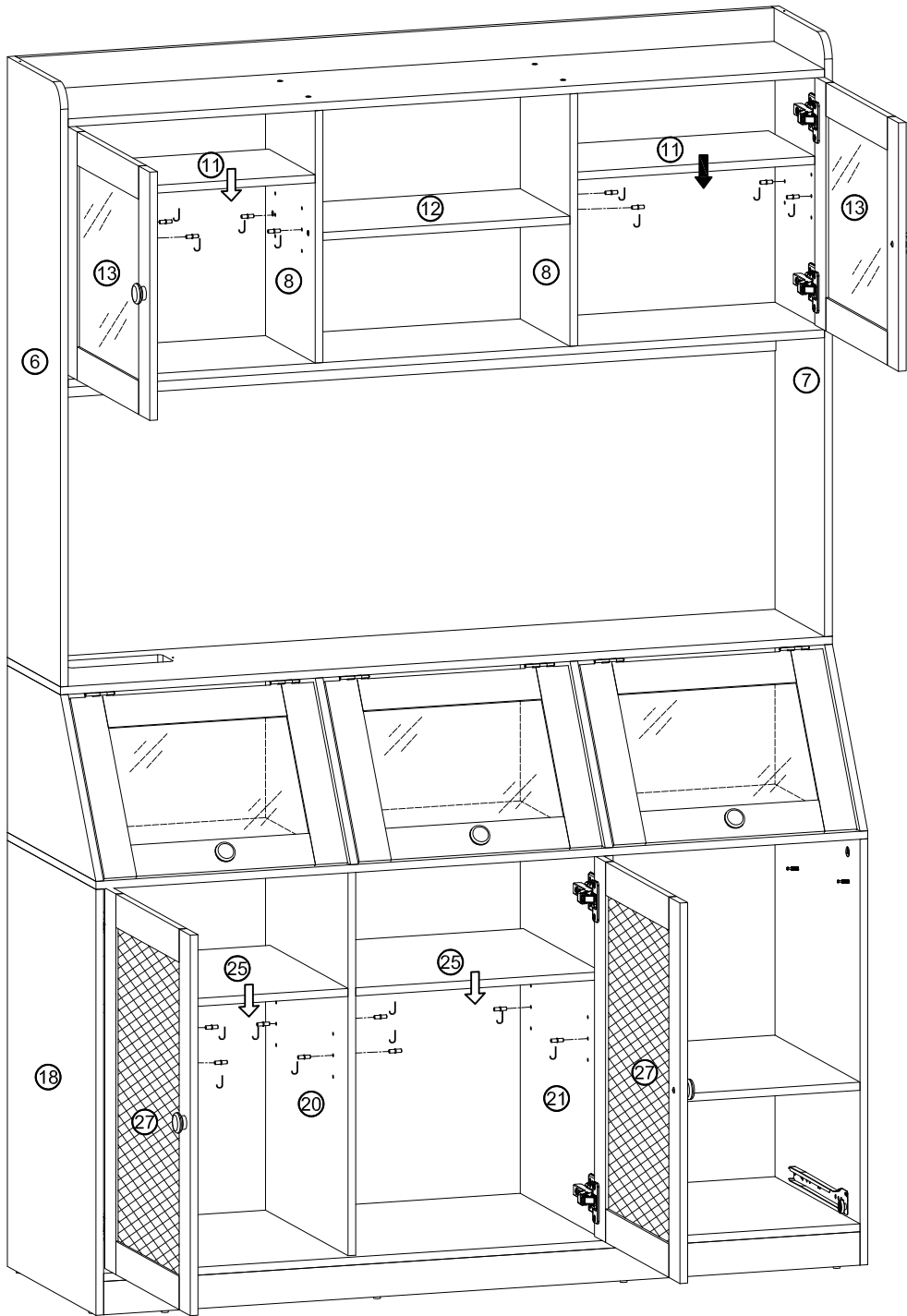

J	x16
5x19mm	

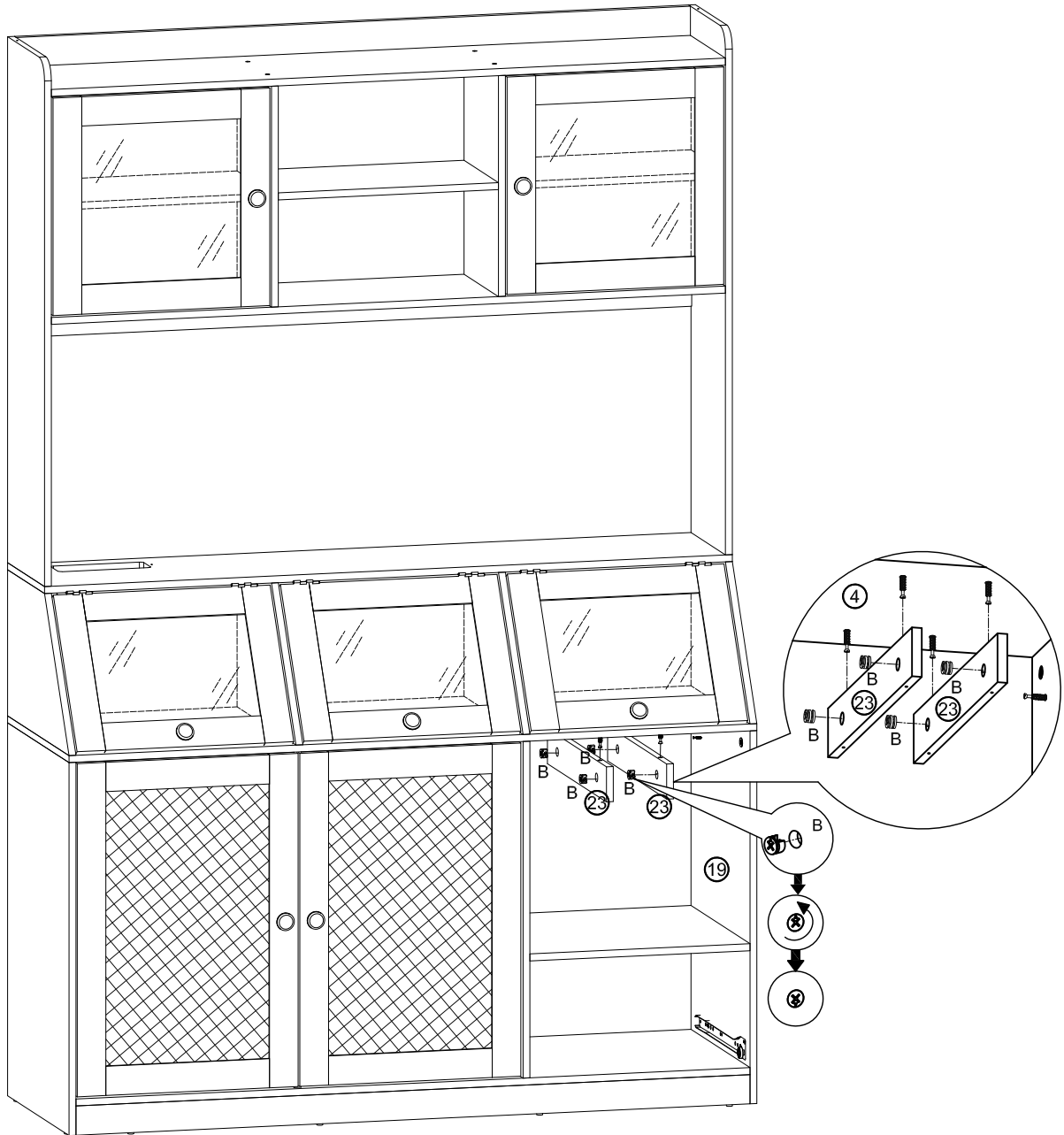

B	x4
	
$\Phi 15\text{mm}$	

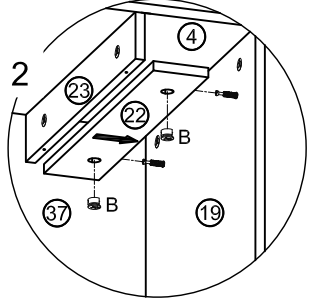
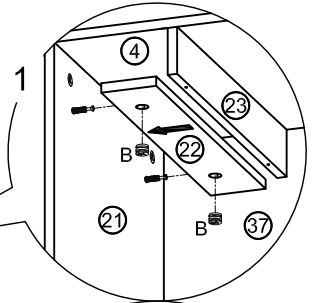
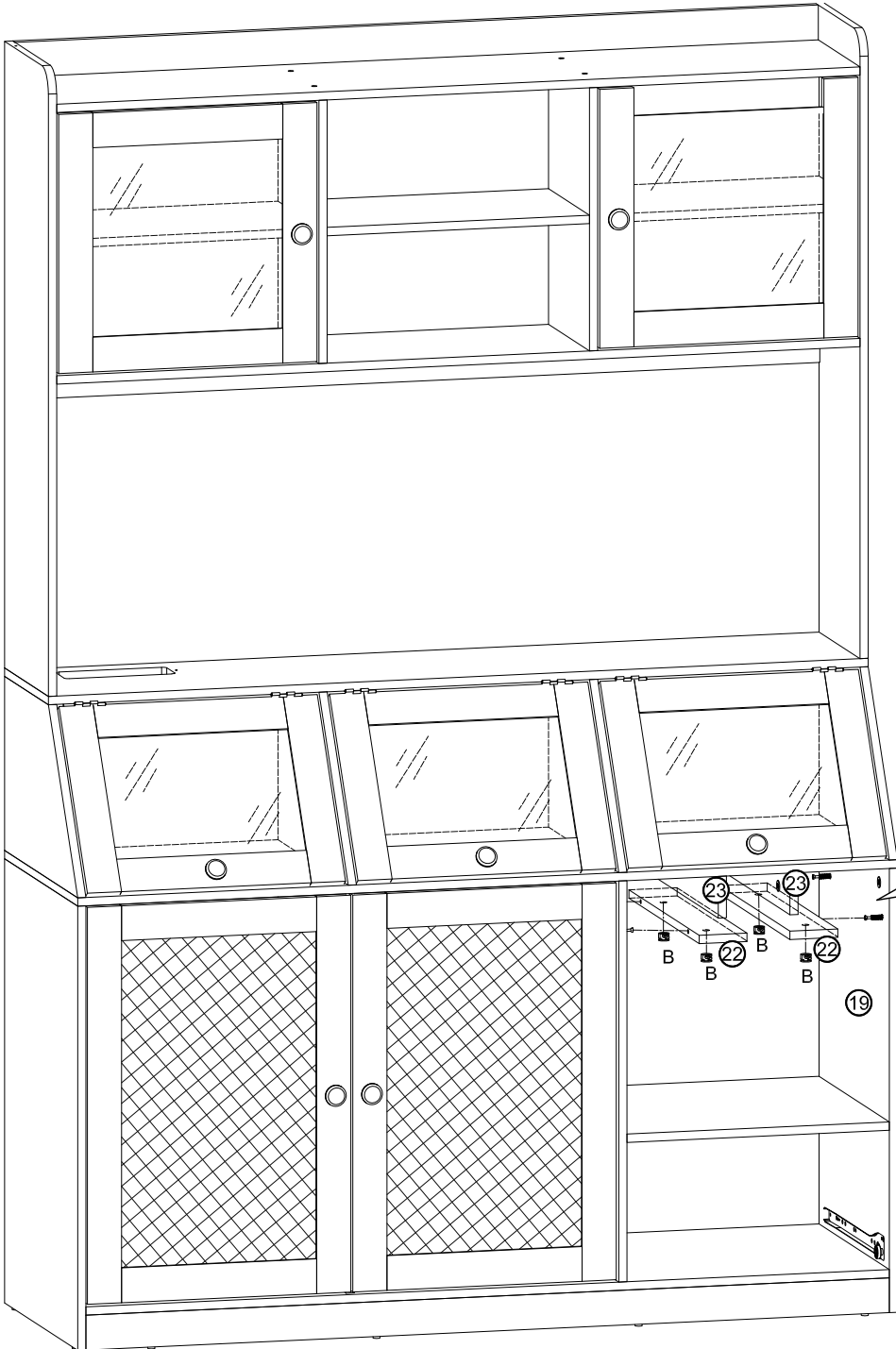

B	x4
	
$\Phi 15\text{mm}$	

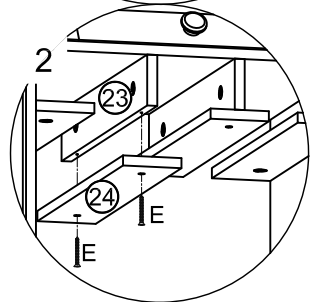
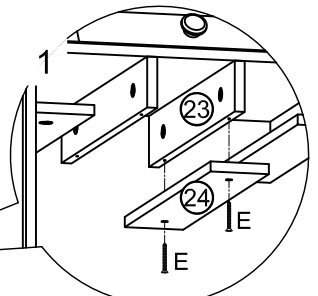
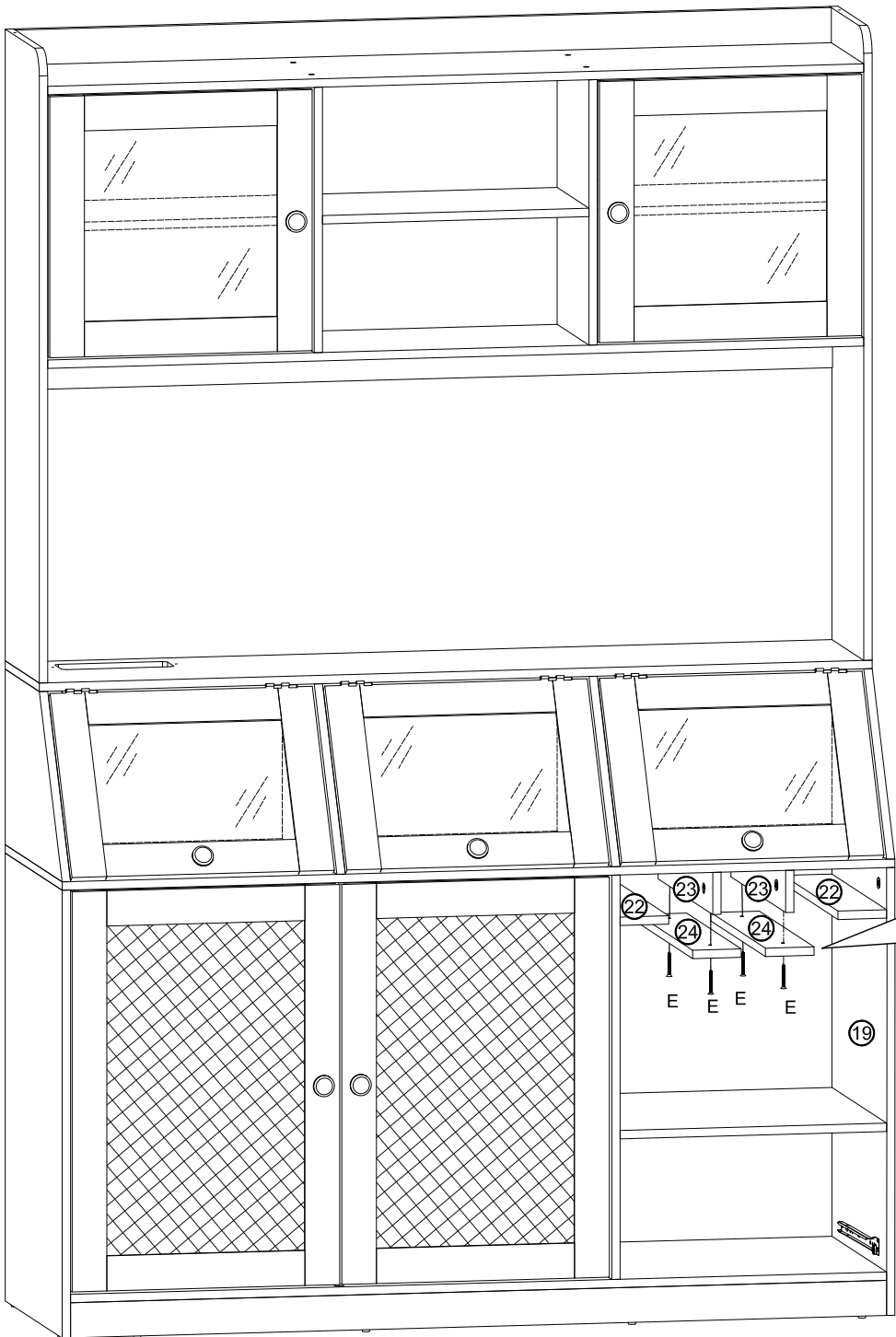

E	x4
	
Φ4x35mm	

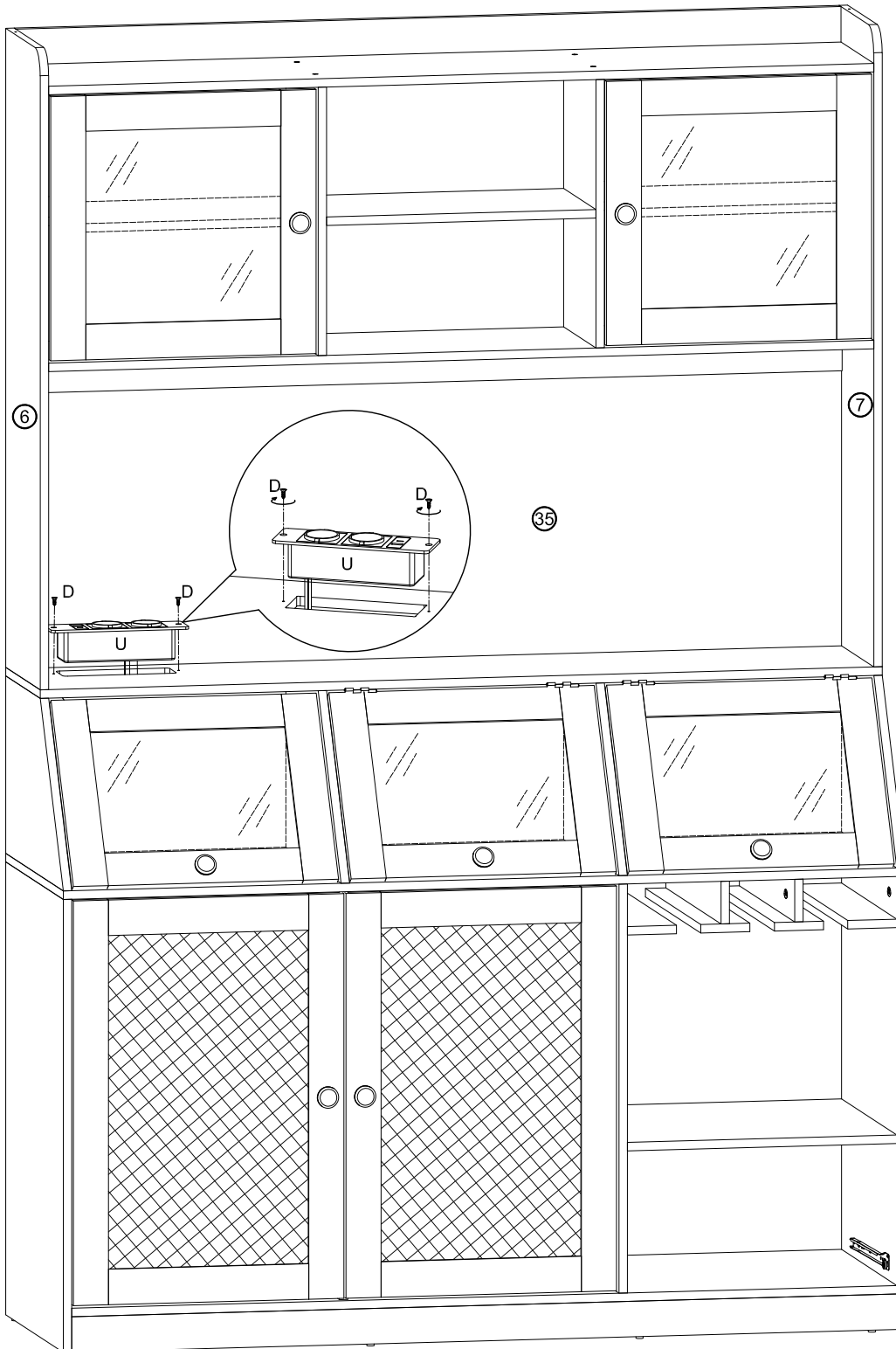

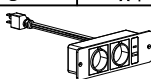
D	x2	U	x1
			
Φ3.5*12mm			

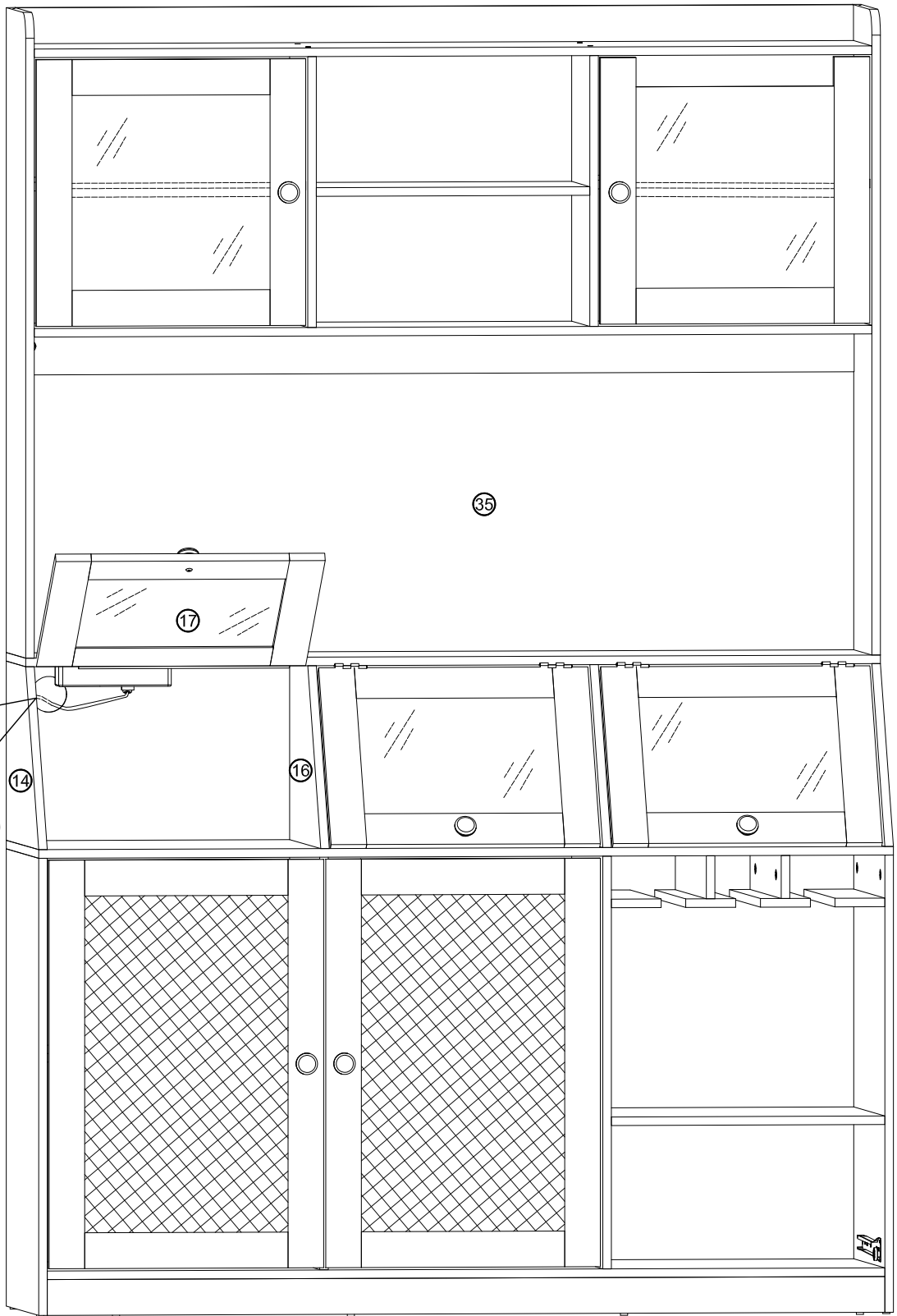

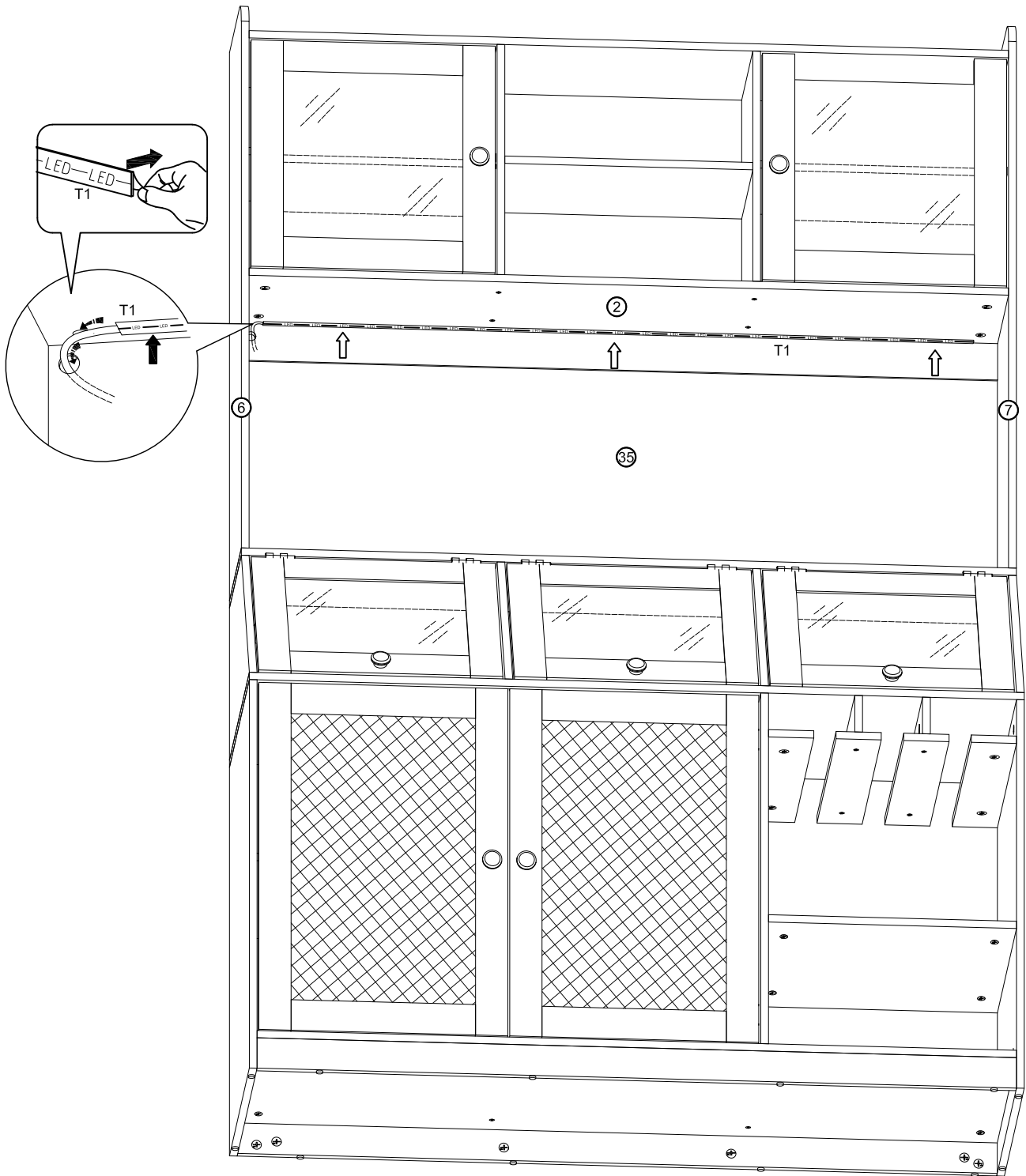



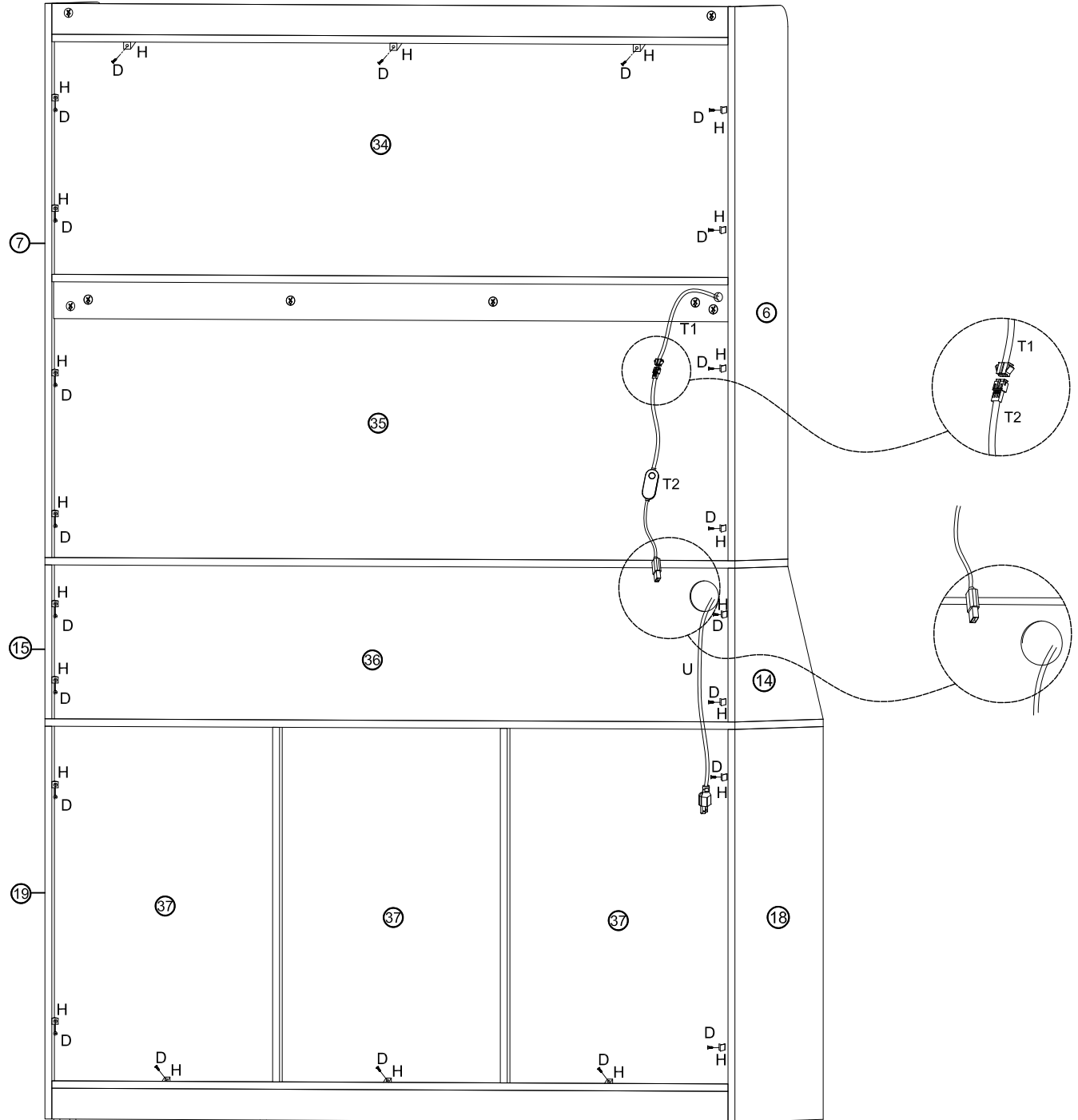

T1	x1
1100mm	

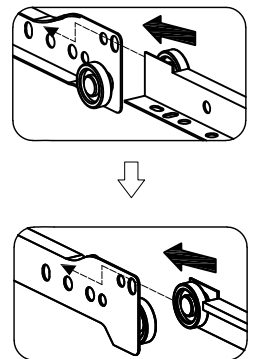
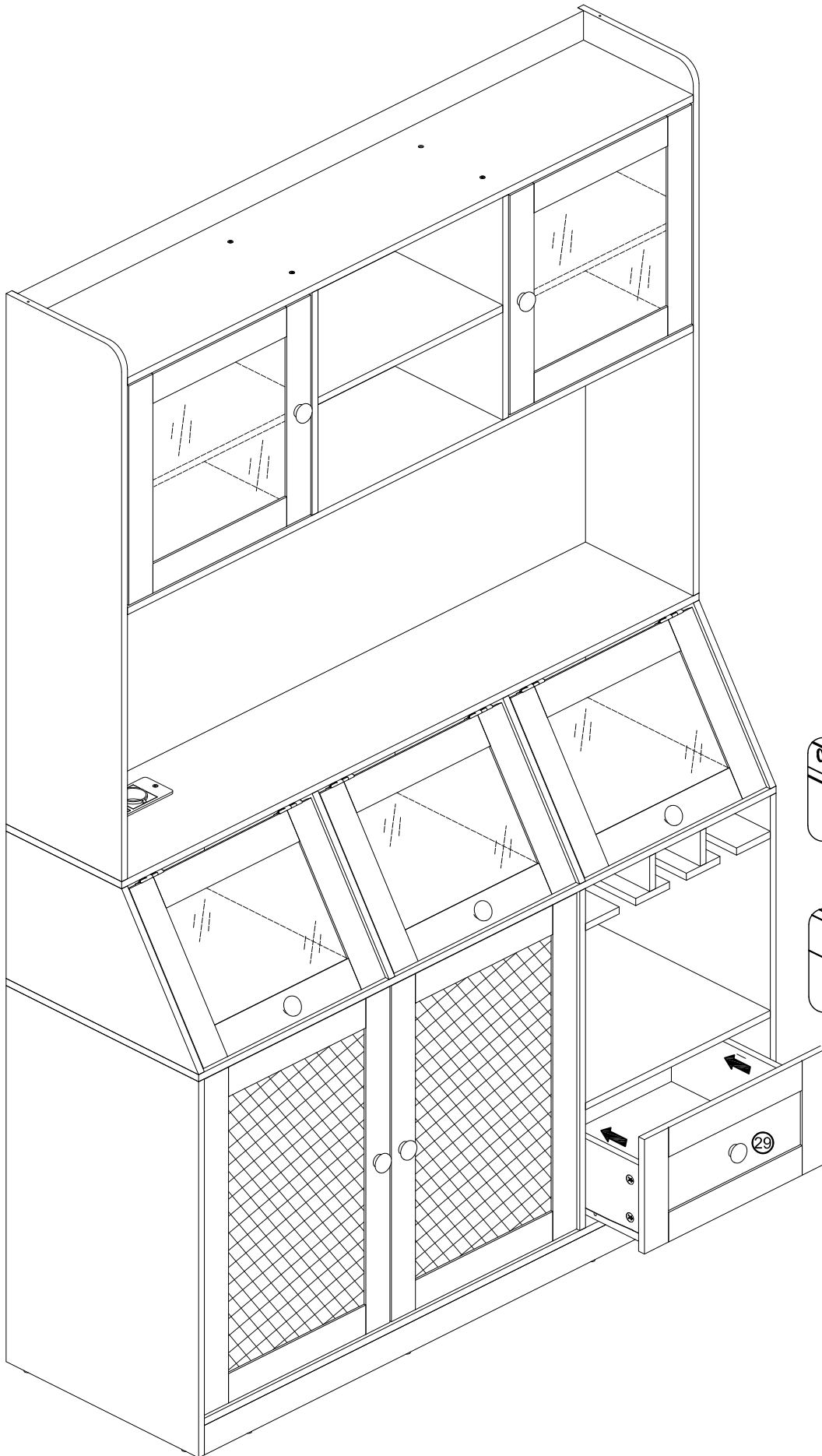

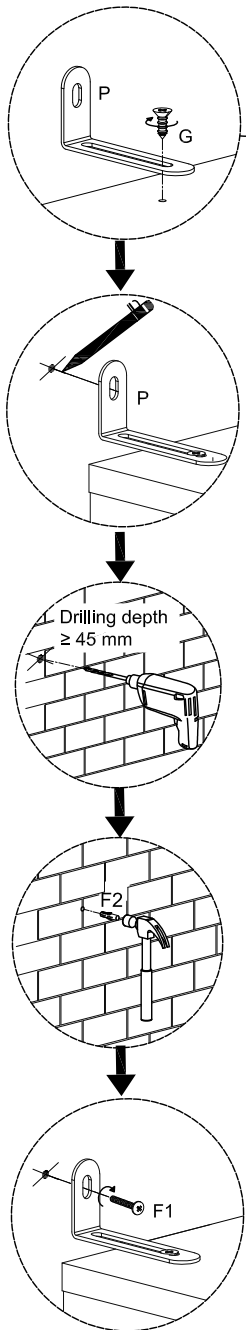
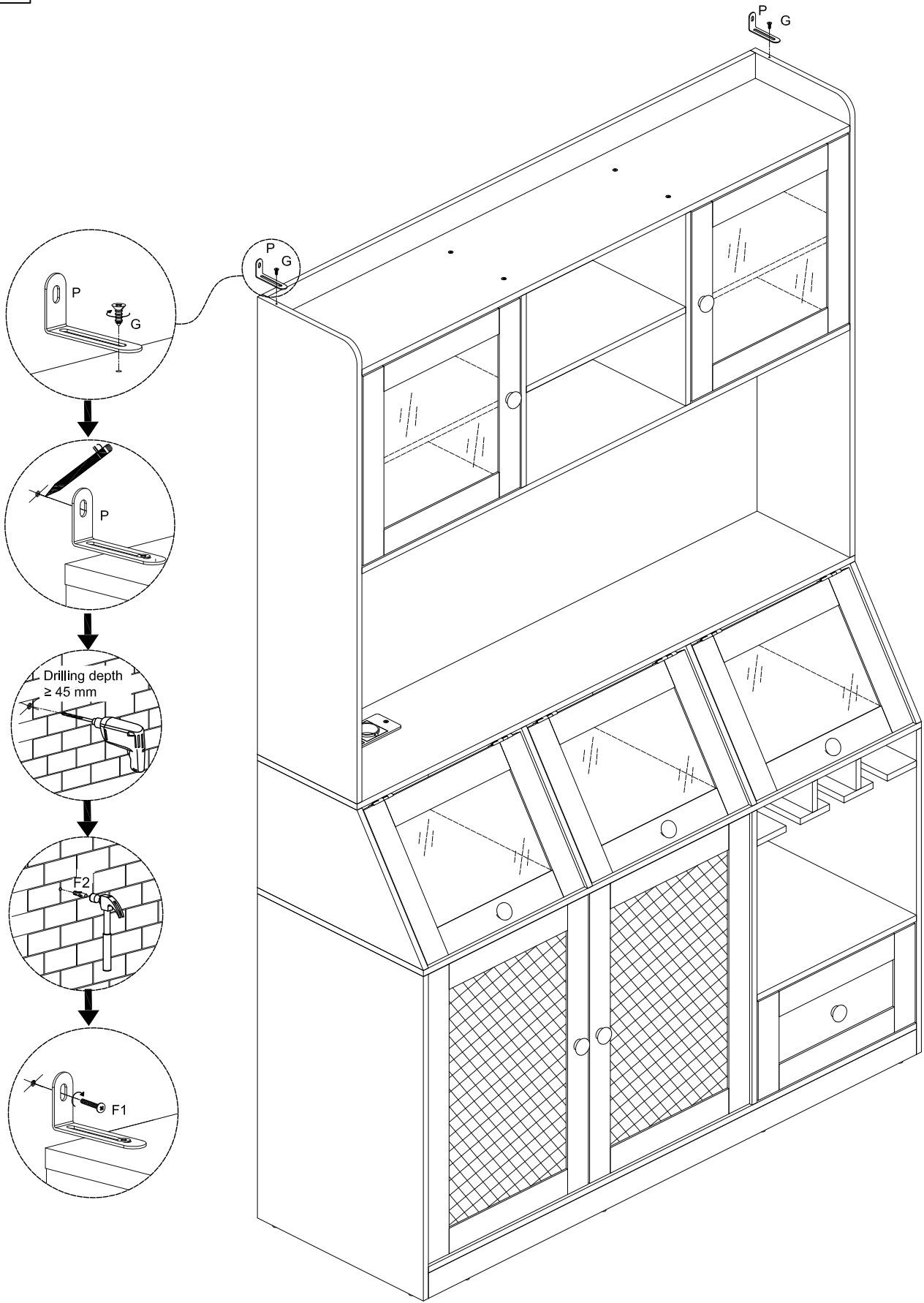
D	x22	H	x22	T2	x1
Φ3.5*12mm		15x10mm			



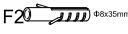

G	x2	F	x2	P	x2
		F1  $\varnothing 4 \times 5 \text{ mm}$			
$\varnothing 4 \times 14 \text{ mm}$		F2  $\varnothing 8 \times 35 \text{ mm}$			

Certificate of Conformity

No.: LP24030331C02-01R1

The following products have been tested by us with the listed standards and found in compliance with the council LVD directive 2014/35/EU. It is possible to use CE marking to demonstrative for the compliance with this LVD Directive.

Applicant : Dongguan Nanfan Electronic Technology Co ., Ltd.
Address : Room 202,NO.19, Wanbu Road, Changping Town 523586
Dongguan Guangdong, China
Product : Socket outlet (Furniture Power Distribution Unit)
Trade Mark : N/A
Model No. : NFxx-EUyy-16A/250Vz (x, y and z are variables , detail see test report)
Rated Input : 250V~, 50/60Hz, 16A
Rated Output: USB output ratings see test report

Test Standards : DIN VDE 0620-1:2021 Plug and socket-outlets for household and similar purposes-Part 1: General
EN IEC 62368-1:2020/Requirements on fixed socket-out
A11:2020 Audio/video, information and
communication technology equipment
Part 1: Safety requirements



Manager: Haylen Li
Date: 2025-05-26

Dongguan Lepont Testing Service Co., Ltd.

Tel.: 86-769-8308 6888 Fax.: 86-769-8309 6886
Room 102, Building 11, No. 7, Houjie Science And Technology
Avenue, Houjie, Dongguan, Guangdong, China

The statement is based on a single evaluation of one sample of above mentioned products. It does not imply an assessment of the whole production and does not permit the use of the test lab's logo.

Certificate of Conformity

No.: LP24030331C02-02

The following products have been tested by us with the listed standards and found in compliance with the council EMC directive 2014/30/EU. It is demonstrative for the compliance with this EMC Directive.

Applicant : Dongguan Nanfan Electronic Technology Co., Ltd.
Address : Room 202,NO.19, Wanbu Road, Changping Town 523586
Dongguan Guangdong, China
Product : Furniture Power Distribution Unit
Model No. : NF-EUxAA-y, NF-EUxAC-y, NF-EUxAAC-y, NF-EUxACC-y
("x", "y" are variables, see page 4 of the test report for details.)
Trade Mark: : NANFAN
Test Standards : EN 55032:2015+A11:2020+A1:2020
EN 55035:2017+A11:2020
EN IEC 61000-3-2:2019+A1:2021
EN 61000-3-3:2013+A1:2019+A2:2021



Manager: Frank Shen
Date: July 15, 2024

Dongguan Lepont Testing Service Co., Ltd.

Tel.:86-769-83086888 Fax.:86-769-83096886

Room 102, Building 11, No.7, Houjie Science And Technology Avenue, Houjie, Dongguan,
Guangdong, China

The statement is based on a single evaluation of one sample of above mentioned products. It does not imply an assessment of the whole production and does not permit the use of the test lab's logo.



Certificate of Conformity

No.:CCI240700866EN-2CER

Reference Report No. : CCI240700866EN-2

Applicant : Dongguan Nanfan Electronic Technology Co ., Ltd.
Address : Room 202,NO.19, Wanbu Road, Changping Town 523586
Dongguan Guangdong, China

Sample Name : Furniture Power Distribution Unit
NF01-EU01, NF02-EU01, NF03-EU01, NF04-EU01, NF01-EU02,
Model/Item No. : NF02-EU02,NF03-EU02, NF04-EU02, NF01-EU03, NF02-EU03,
NF02-EU03 ,NF04-EU03,NF01-EU04, NF02-EU04, NF03-EU04,
NF04-EU04

Test Standards : IEC 62321-4: 2013+A1:2017 IEC 62321-7-1:2015
IEC 62321-5: 2013 IEC 62321-7-2:2017
IEC 62321-6:2015 IEC 62321-8:2017

The submitted sample(s) stated as above has(have) been tested by us with the listed standards and found in conformity with the requirements stated in Directive 2011/65/EU of the European Parliament and of the Council with regard to the restriction of the use of certain hazardous substances in electrical and electronic equipment and its subsequent amendments as well as Commission Delegated Directive (EU) 2015/863. It is possible to use CE marking on the product to demonstrate the conformity with this Directive.

This certification is part of the full test report(s) and should be read in conjunction with it. The certificate is based on a single evaluation of one sample of above-mentioned products. It does not imply an assessment of the whole production. Other CE marking directives may be applied, they have not been considered during this RoHS conformity assessment.



Technical director
Aug. 13, 2024

Shenzhen ZKT Technology Co., Ltd.

1/F, No. 101, Building B, No. 6, Tangwei Community Industrial Avenue,
Fuhai Street, Bao'an District, Shenzhen, China



Certificate of Compliance

Certificate Number: ZKT-25070715599C-R1

Certificate's Holder : Natulighting(shenzhen) TechnologyCo.,LTD
2nd Floor, Building A9, Xinghua Xiong Industrial Park,
Baihuadong, Guangming District, Shenzhen

Manufacturer : Natulighting(shenzhen) TechnologyCo.,LTD
2nd Floor, Building A9, Xinghua Xiong Industrial Park,
Baihuadong, Guangming District, Shenzhen

Trade Mark : N/A

Product : Colorful Light strip

Model(s) : 5V-60-RGB
5V-30-RGB

REQUIREMENT	STANDARD	Report No.
Art.3.1(a) Safety	EN IEC 62368-1:2024+A11:2024	ZKT-25070715600S-R1
Art.3.1(a) Health	EN IEC 62311:2020 EN 50665:2017	ZKT-25070715599E-1-R1
Art.3.1(b) EMC	ETSI EN 301 489-1 V2.2.3 (2019-11) ETSI EN 301 489-17 V3.3.1 (2024-09) ETSI EN 301 489-3 V2.3.2 (2023-01)	ZKT-25070715599E-2-R1
Art.3.2 Radio	ETSI EN 300 328 V2.2.2 (2019-07)	ZKT-25070715599E-3-R1
	ETSI EN 300 440 V2.2.1 (2018-07)	ZKT-25070715599E-4-R1

This Attestation of Compliance is issued on a voluntary basis for electrical equipment below the voltage limits of Radio Equipment Directive (RED) 2014/53/EU. The essential requirements are fulfilled accordingly based on the technical specifications applicable at the time of issuance.



Manager
Sep. 19, 2025

This Certificate of Conformity is based on single evaluation of the submitted sample(s) of the above mentioned product. It does not imply an assessment of the whole product and relevant Directives to be observed.

Shenzhen ZKT Technology Co., Ltd.

1/F, No. 101, Building B, No. 6, Tangwei Community Industrial Avenue,
Fuhai Street, Bao'an District, Shenzhen, China



Certificate of Compliance

Certificate Number: ZKT-24122719690C

- Certificate's Holder** : Natu lighting (Shenzhen) Technology Co.,LTD.
Floor 4, Building 3, Zone E, Xinyongfeng Industrial Park,
Shilong Avenue, Shiyan Shuitian Scommunity,
Baoan District, Shenzhen
- Manufacturer** : Natu lighting (Shenzhen) Technology Co.,LTD.
Floor 4, Building 3, Zone E, Xinyongfeng Industrial Park,
Shilong Avenue, Shiyan Shuitian Scommunity,
Baoan District, Shenzhen
- Trade Mark** : NT
- Product** : Colorful light strip
- Model(s)** : 5V-60-RGB
5V-30-RGB
- Test Standard** : EN IEC 55015:2019/A11:2020, EN IEC 61547:2023,
EN IEC 61000-3-2:2019/A1:2021/A2:2024,
EN 61000-3-3:2013/A1:2019/A2:2021,
EN 61000-4-2:2009, EN IEC 61000-4-3:2020,
EN 61000-4-4:2012, EN 61000-4-5:2014/A1:2017,
EN IEC 61000-4-6:2023, EN 61000-4-8:2010,
EN IEC 61000-4-11:2020

This Attestation of Compliance is issued on a voluntary basis for electrical equipment below the voltage limits of EMC Directive 2014/30/EU. The essential requirement are fulfilled accordingly based on the technical specifications applicable at the time of issuance. See also notes overleaf. It is only valid in connection with the test report number: ZKT-24122719690E.



This Certificate of Conformity is based on single evaluation of the submitted sample(s) of the above mentioned product. It does not imply an assessment of the whole product and relevant Directives to be observed.

Shenzhen ZKT Technology Co., Ltd.

1/F, No. 101, Building B, No. 6, Tangwei Community Industrial Avenue,
Fuhai Street, Bao'an District, Shenzhen, China



Certificate of Compliance

Certificate Number: ZKT-24122719691C

Certificate's Holder	: Natu lighting (Shenzhen)Technology Co.,LTD. Floor 4, Building 3, Zone E, Xinyongfeng Industrial Park, Shilong Avenue, Shiyan Shuitian Scommunity, Baoan District, Shenzhen
Manufacturer	: Natu lighting (Shenzhen)Technology Co.,LTD. Floor 4, Building 3, Zone E, Xinyongfeng Industrial Park, Shilong Avenue, Shiyan Shuitian Scommunity, Baoan District, Shenzhen
Trade Mark	: NT
Product	: Colorful light strip
Model(s)	: 5V-60-RGB 5V-30-RGB
Test Method	: IEC 62321-3-1:2013, IEC 62321-4:2013+A1:2017, IEC 62321-5:2013, IEC 62321-6:2015, IEC 62321-7-1:2015, IEC 62321-7-2:2017, IEC 62321-8:2017

The following products have been tested by us and found in conformity with the (RoHS) Directive 2011/65/EU Annex II amending Annex (EU)2015/863 and amending Annex (EU)2017/2102. It is possible to use CE Marking to demonstrate the conformity with this Directive.It is only valid in connection with the test report number: ZKT-24122719691R.

RoHS

Manager
Jan. 03, 2025

This Certificate of Conformity is based on single evaluation of the submitted sample(s) of the above mentioned product. It does not imply an assessment of the whole product and relevant . Directives to be observed.