

Montageanleitung | Instructions de montage Assembly Instructions | Instrucciones de montaje

SKU NUMBER:

N623P457241

N623P457242

N623P457243

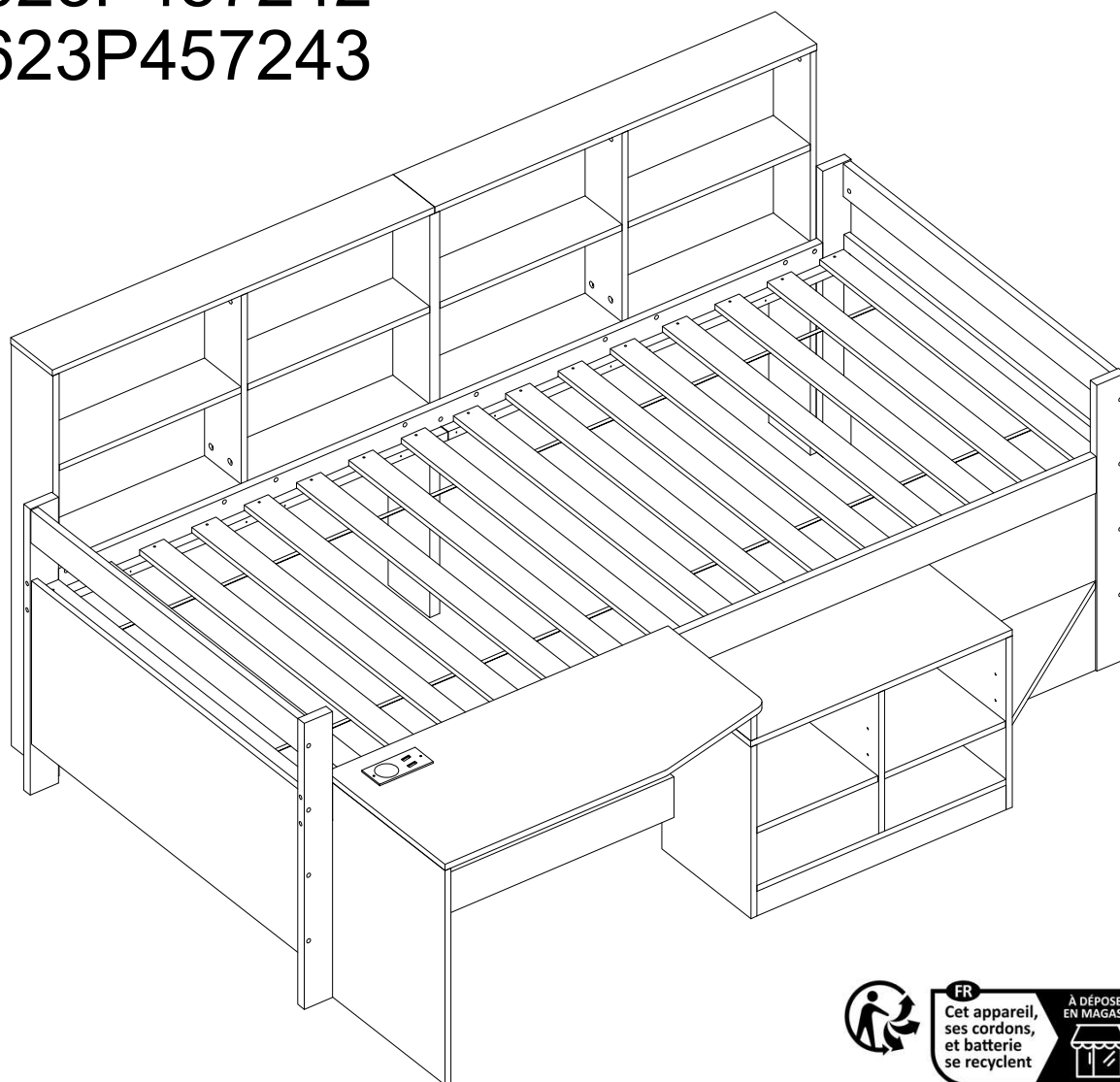
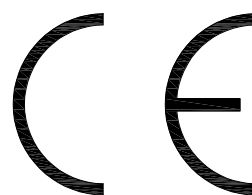

Points de collecte sur www.quefairedemesdechets.fr
Privilégiez la réparation ou le don de votre appareil !

GB This set comes in 3 boxes. If you do not receive a full set of 3 boxes, please contact our customer service.

DE Dieses Set wird in 3 Schachteln geliefert. Wenn Sie nicht einkomplettes Set von 3 Boxen erhalten, kontaktieren Sie bitte unseren Kundenservice.

FR Ce set est livré en 3 boîtes. Si vous ne recevez pas un jeu complet de 3 boîtes, veuillez contacter notre service clientèle.

English

IMPORTANT ! KEEP FOR FUTURE REFERENCE : READ CAREFULLY

- To be assembled by an adult. Assembly must be checked by an adult before use
- **WARNING !** Keep all screws, small parts and plastic bags out of the reach of children
- Properly identify all parts before assembling
- Never use your item if any of its parts are broken or missing
- Should any problems arise, please contact our After Sales Service
- Manufacturer's instructions shall be followed at all times
- Care: Clean with a soft, dry cloth. In case of larger stains, carefully rub with a slightly damp, non-abrasive sponge
- Avoid the risk of fire by not placing furniture near sources of ignition or hot items
- Do not jump on the bed

Deutsch

WICHTIG ! ZUM SPÄTEREN NACHSCHLAGEN AUFBEWAHREN: SORGFÄLTIG LESEN

- Muss von einem Erwachsenen zusammengebaut werden. Der Zusammenbau muss vor dem Gebrauch von einem Erwachsenen überprüft werden
- **WARNUNG!** Bewahren Sie alle Schrauben, Kleinteile und Plastikbeutel außerhalb der Reichweite von Kindern auf
- Kennzeichnen Sie vor dem Zusammenbau alle Teile richtig
- Benutzen Sie Ihren Artikel niemals, wenn Teile gebrochen sind oder fehlen
- Sollten Probleme auftreten, wenden Sie sich bitte an unseren Kundendienst
- Die Anweisungen des Herstellers sind stets zu befolgen
- Pflege: Mit einem weichen, trockenen Tuch reinigen. Bei größeren Flecken vorsichtig mit einem leicht feuchten, nicht scheuernden Schwamm abreiben. nicht scheuernden Schwamm
- Vermeiden Sie die Gefahr eines Brandes, indem Sie die Möbel nicht in der Nähe von Zündquellen oder heißen Gegenständen aufstellen
- Nicht auf das Bett springen

Français

IMPORTANT ! CONSERVER POUR RÉFÉRENCE ULTÉRIEURE : LIRE ATTENTIVEMENT

- Le montage doit être effectué par un adulte. Le montage doit être vérifié par un adulte avant Utilisation
- **ATTENTION !** Tenir les vis, les petites pièces et les sachets en plastique hors de portée des enfants
- Identifiez correctement toutes les pièces avant de les assembler
- N'utilisez jamais votre article si l'une de ses pièces est cassée ou manquante
- En cas de problème, veuillez contacter notre service après-vente
- Les instructions du fabricant doivent être respectées à tout moment
- Entretien : nettoyer avec un chiffon doux et sec. En cas de taches plus importantes, frotter soigneusement avec une éponge non abrasive légèrement humide. légèrement humide et non Abrasive
- Évitez les risques d'incendie en ne plaçant pas les meubles à proximité de sources d'inflammation ou d'objets chauds
- Ne pas sauter sur le lit

Italiano

IMPORTANTE! CONSERVARE PER RIFERIMENTO FUTURO: LEGGERE ATTENTAMENTE

- Deve essere assemblato da un adulto. L'assemblaggio deve essere controllato da un adulto prima dell'uso
- **ATTENZIONE!** Tenere tutte le viti, le piccole parti e i sacchetti di plastica fuori dalla portata dei bambini
- Identificare correttamente tutte le parti prima dell'assemblaggio
- Non utilizzare mai l'articolo se alcune parti sono rotte o mancanti
- In caso di problemi, si prega di contattare il nostro Servizio Post Vendita
- Le istruzioni del produttore devono essere sempre seguite
- Cura: Pulire con un panno morbido e asciutto. In caso di macchie più estese, strofinare accuratamente con una spugna leggermente umida e nonspugna leggermente umida e non abrasiva
- Evitare il rischio di incendio, non collocando i mobili vicino a fonti di accensione o a oggetti caldi
- Non saltare sul letto

Español

¡ IMPORTANTE ! CONSERVELO PARA FUTURAS CONSULTAS: LEA ATENTAMENTE

- Debe ser montado por un adulto. El montaje debe ser comprobado por un adulto antes del uso
- ADVERTENCIA** Mantenga todos los tornillos, piezas pequeñas y bolsas de plástico fuera del alcance de los niños.
- Identifique correctamente todas las piezas antes de montarlas
 - Nunca utilice su artículo si alguna de sus piezas está rota o falta
 - Si surge algún problema, póngase en contacto con nuestro Servicio Postventa
 - Las instrucciones del fabricante deben seguirse en todo momento
 - Cuidado: Limpiar con un paño suave y seco. En caso de manchas más grandes, frote cuidadosamente con una esponja no abrasiva ligeramente humedecida.
 - Evite el riesgo de incendio no colocando los muebles cerca de fuentes de ignición u objetos calientes.
 - No saltar sobre la cama.

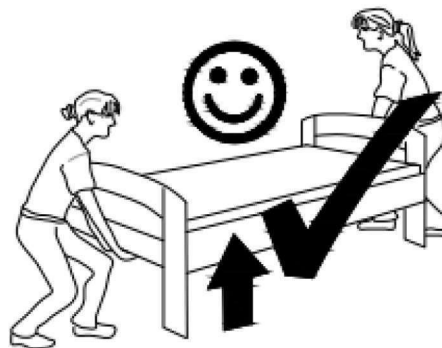
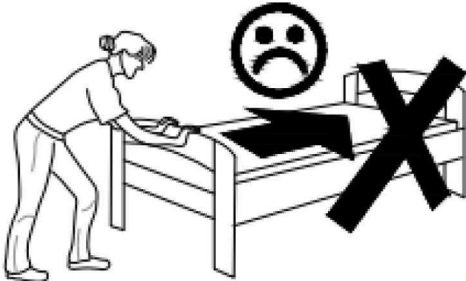

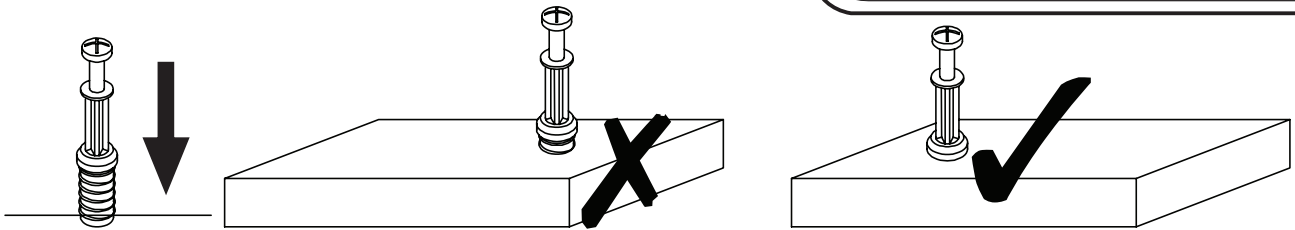

EN_QUICKFIT: Tighten quickfit until shoulder is flush with panel. Do not overtighten or undertighten.

FR_RACCORD RAPIDE: Faites serrer le raccord rapide jusqu'à ce que l'épaulement soit parfaitement encastré dans le panneau. Il ne faut ni trop serrer ni insuffisamment serrer.

ES_QUICKFIT: Apriete quickfit hasta que el hombro se descargue con el panel. NO lo sobreapriete ni lo apriete poco.

DE_QUICKFIT: Ziehen Sie den Quickfit fest, bis die Schulter mit der Platte bündig ist. Bitte nicht zu fest oder zu schwach anziehen.

IT_MONTAGGIO RAPIDO: Stringere il montaggio rapido fino a quando la spalla è a filo con il pannello, non stringere troppo o troppo poco.

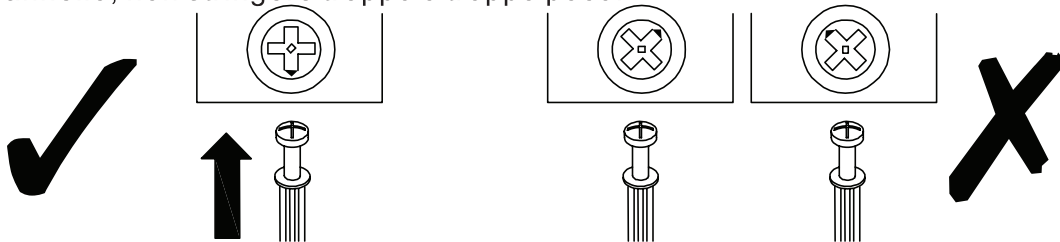

EN_CAM LOCK: When fitting cam lock, ensure starting position is correct before you insert connecting quickfit.

FR_SERRURE BATTEUSE: Avant d'insérer la serrure batteuse, veillez à la bonne orientation avant d'insérer le raccord rapide.

ES_CIERRE DE LA CÁMARA: Cuando instale el cierre de la cámara, asegúrese de que la posición de inicio es correcta antes de que inserte el quickfit conector.

DE_CAM-LOCK: Achten Sie bei der Montage des Cam-Locks auf die richtige Ausgangsposition, bevor Sie den Quickfit einsetzen.

IT_BLOCCAGGIO A CAMMA: Quando si monta il bloccaggio a camma, assicurarsi che la posizione iniziale sia corretta prima di inserire il montaggio rapido di collegamento.

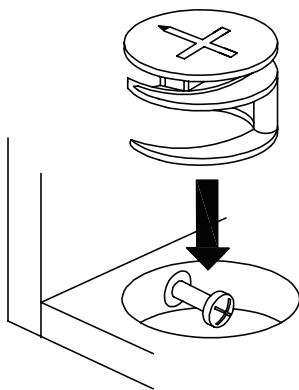

EN_Quickfit head should be in the centre of the cam lock when the two panels are joined.

Cam lock should be inserted before quickfit.

FR_Lorsque les deux panneaux sont assemblés, la tête du raccord rapide doit reposer au centre de la serrure batteuse. Il faut insérer la serrure batteuse avant le raccord rapide.

ES_El cabezal del quickfit debe estar en el centro del cierre de la cámara cuando se unan los dos paneles.

Se debe insertar el cierre de la cámara antes que el quickfit.

DE_Der Quickfit-Kopf sollte sich in der Mitte des Cam-Locks befinden, wenn die beiden Platten zusammengefügt sind. Der Cam-Lock sollte vor dem Quickfit eingesetzt werden.

IT_La testa del montaggio rapido deve trovarsi al centro del bloccaggio a camma quando i due pannelli sono uniti.

Il Bloccaggio a Camma deve essere inserito prima del montaggio rapido.

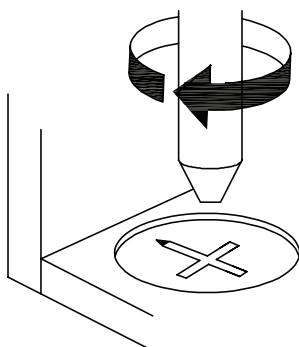

EN_Turn cam lock clockwise to tighten.

FR_Faites tourner la serrure batteuse dans le sens des aiguilles d'une montre pour la resserrer.

ES_Gire el cierre de la cámara en sentido horario para apretarlo.

DE_Drehen Sie den Cam-Lock im Uhrzeigersinn, um ihn festzuziehen.

IT_Ruotare il bloccaggio a camma in senso orario per stringere.

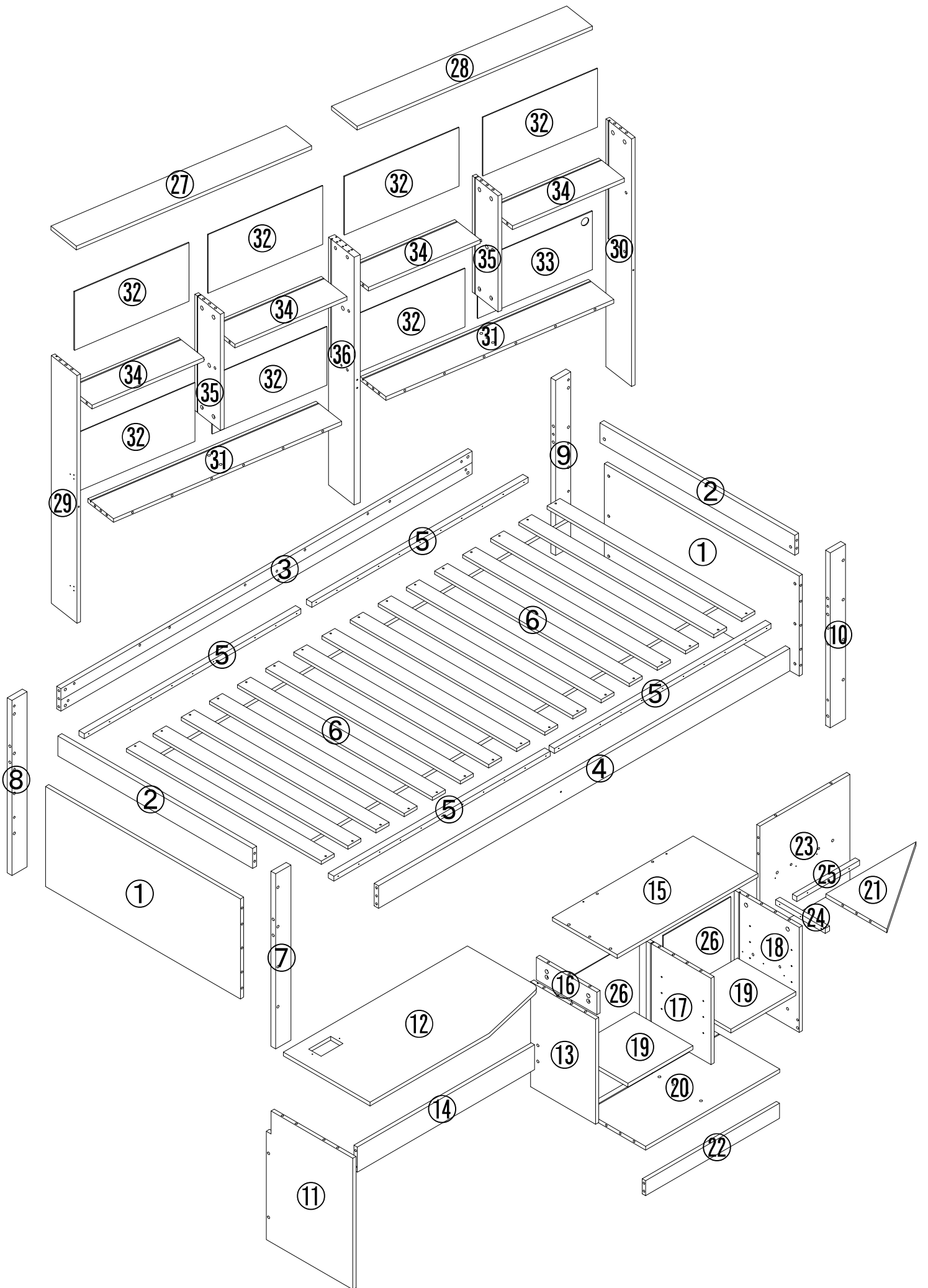

N623P457241

②

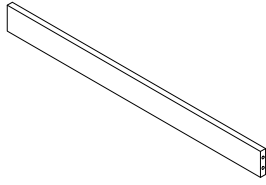

2PCS

⑧

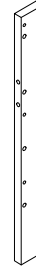

1PC

③

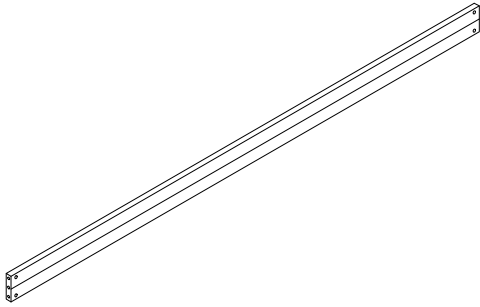

1PC

⑨



1PC

④

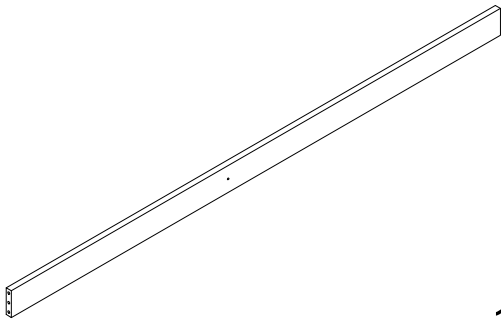

1PC

⑩



1PC

⑤

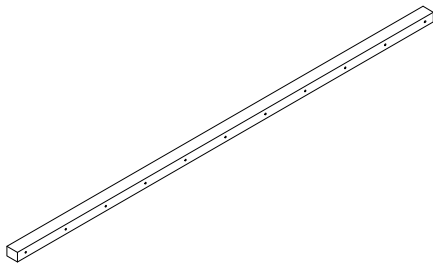

4PCS

⑳

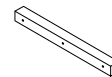

1PC

⑥

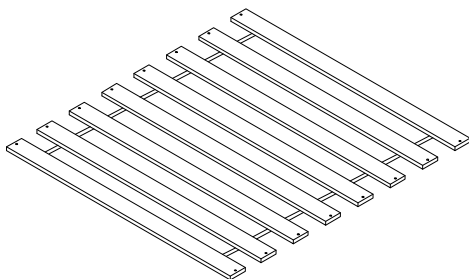

2PCS

㉕

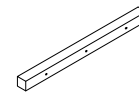

1PC

⑦



1PC

N623P457242

①

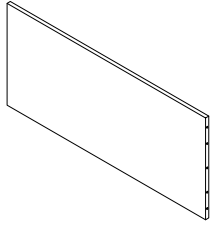

2PCS

⑱

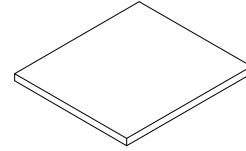

2PCS

⑪

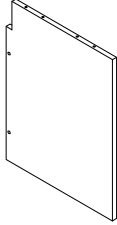

1PC

⑳

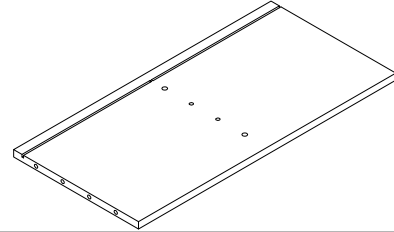

1PC

⑫

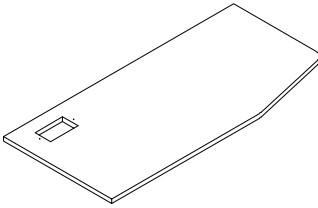

1PC

㉑

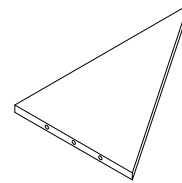

1PC

⑬

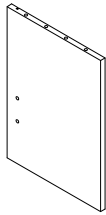

1PC

㉒

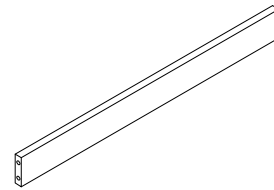

1PC

⑮

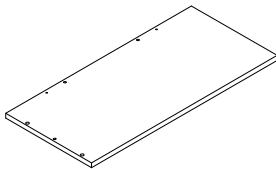

1PC

㉓

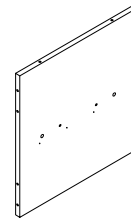

1PC

⑯

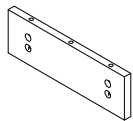

1PC

㉔

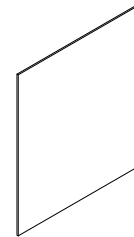

2PCS

⑰

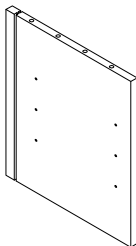

1PC

F

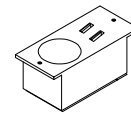

1PC

⑱

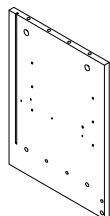

1PC

T

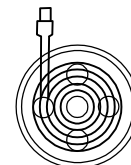

1PC

N623P457243

14

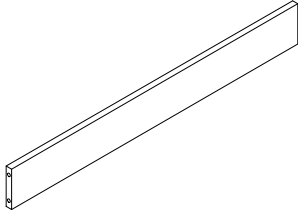

1PC

34

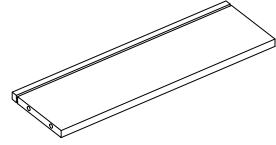

4PCS

27

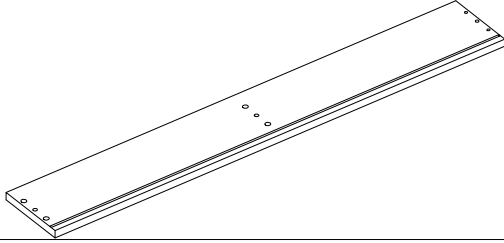

1PC

35

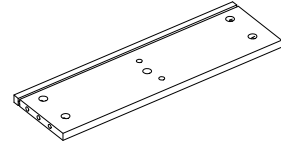

2PCS

28

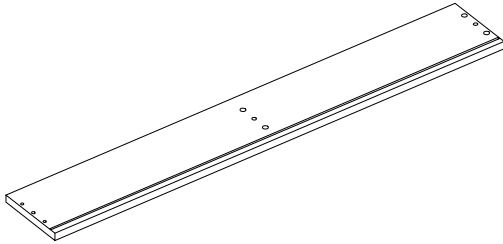

1PC

36

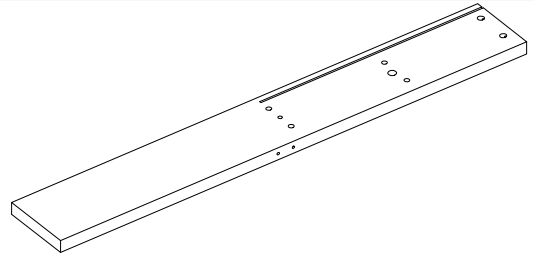

1PC

29

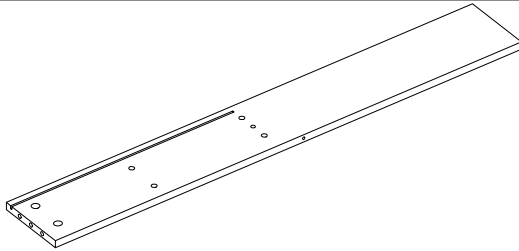

1PC

Hardware

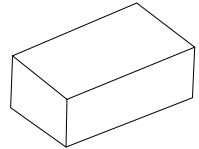

30

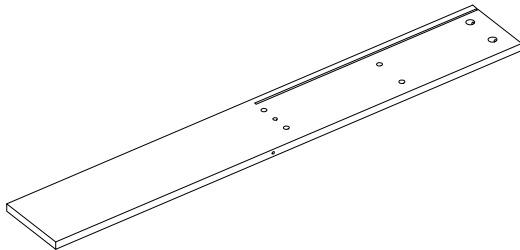

1PC

31

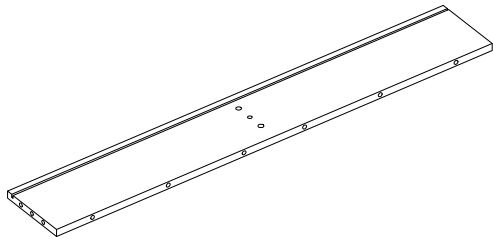

2PCS

32

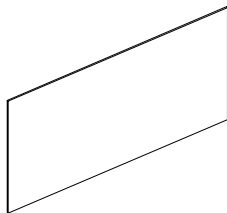





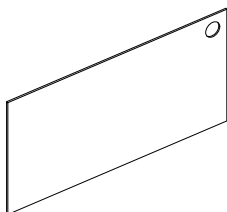

7PCS

33

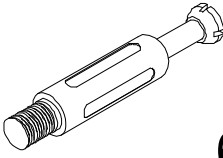
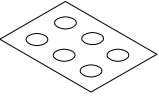

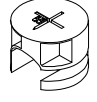
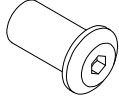

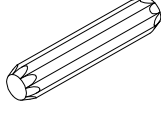
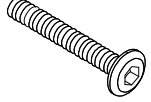
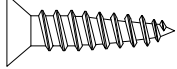
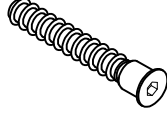
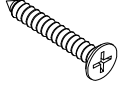
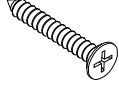
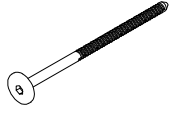
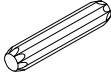
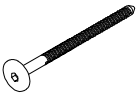
1PC

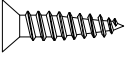
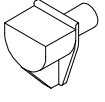
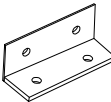
N623P457243

<p>A  40mm 62PCS</p>	<p>L  54PCS</p>	<p>W  32PCS</p>
<p>B  15*10 66PCS</p>	<p>M  6PCS</p>	<p>M4  2PCS</p>
<p>C  8*40 61PCS</p>	<p>N  6*25 6PCS</p>	
<p>D  3.5*14 2PCS</p>	<p>P  7*50 21PCS</p>	
<p>E  3*30 32PCS</p>	<p>Q  4*30 44PCS</p>	
<p>G  6*120 10PCS</p>	<p>R  6*30 2PCS</p>	
<p>H  6*70 16PCS</p>	<p>S  4PCS</p>	
<p>J  26PCS</p>	<p>U  3.5*14 48PCS</p>	
<p>K  8PCS</p>	<p>V  4PCS</p>	

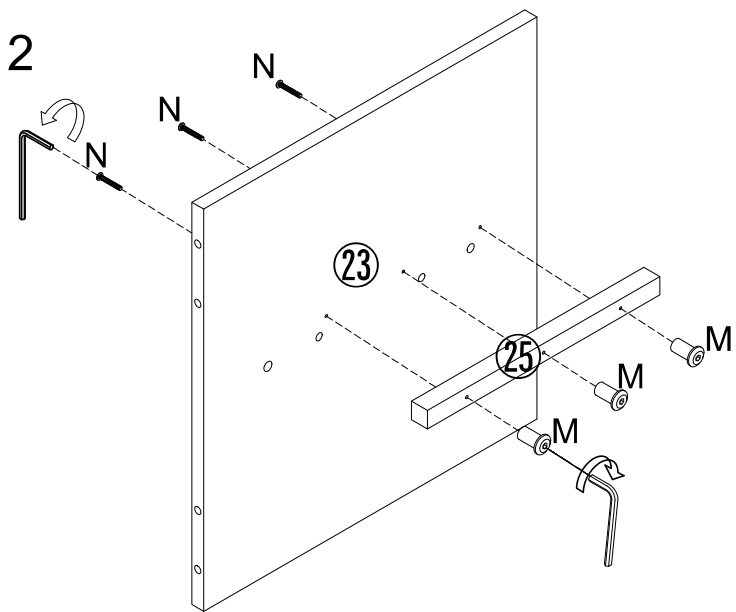
2



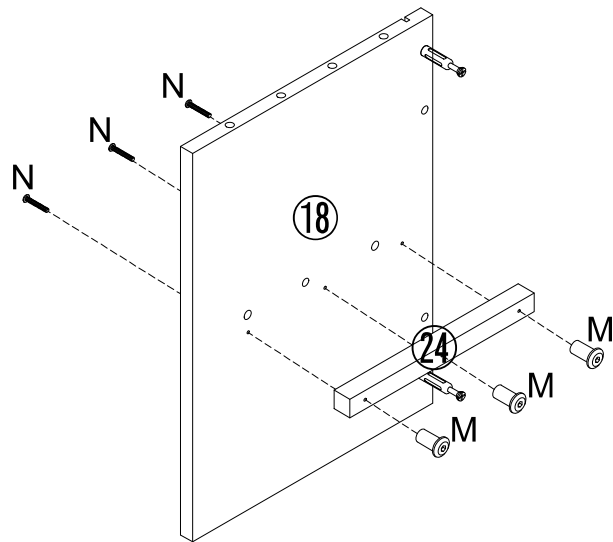

- M  6PCS
- N  6*25 6PCS

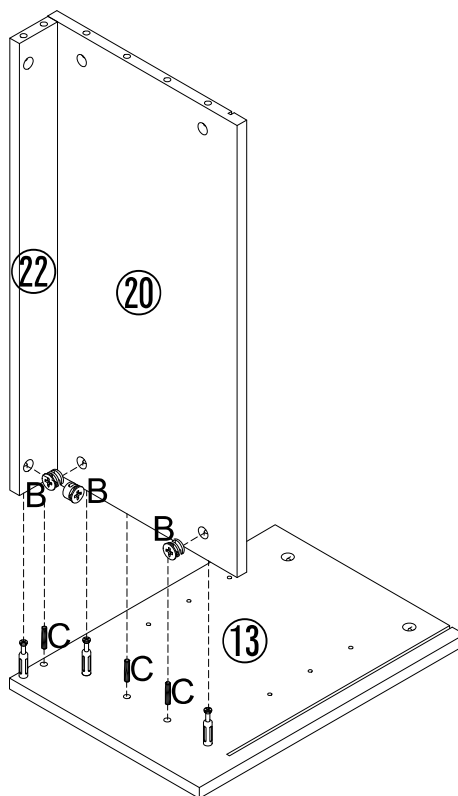
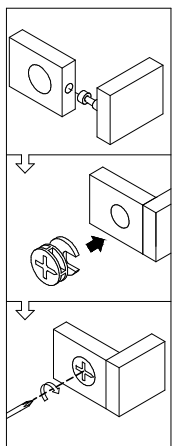

3



- B  3PCS 8*40
- C  3PCS

4

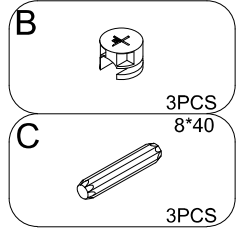
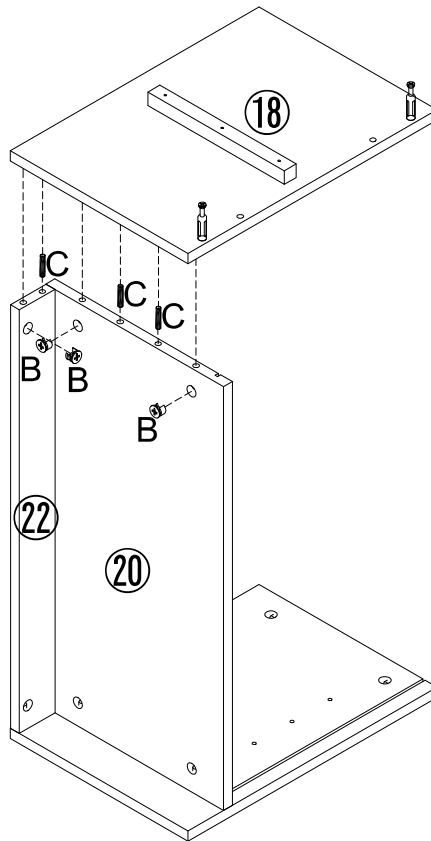
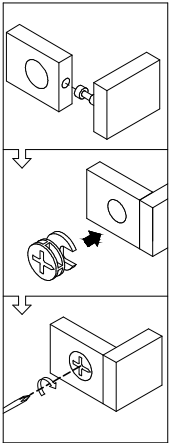

5

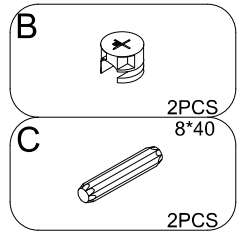
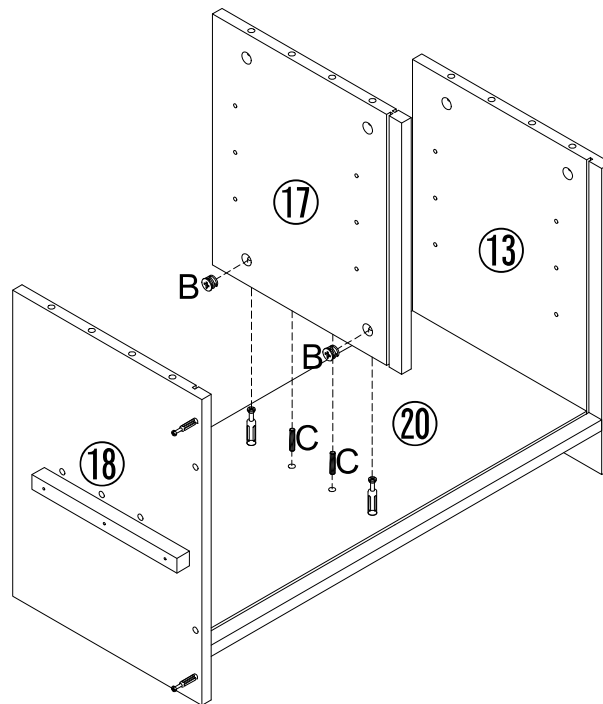
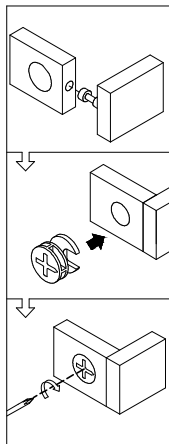

6

- C 8*40
2PCS
- P 8*40
2PCS

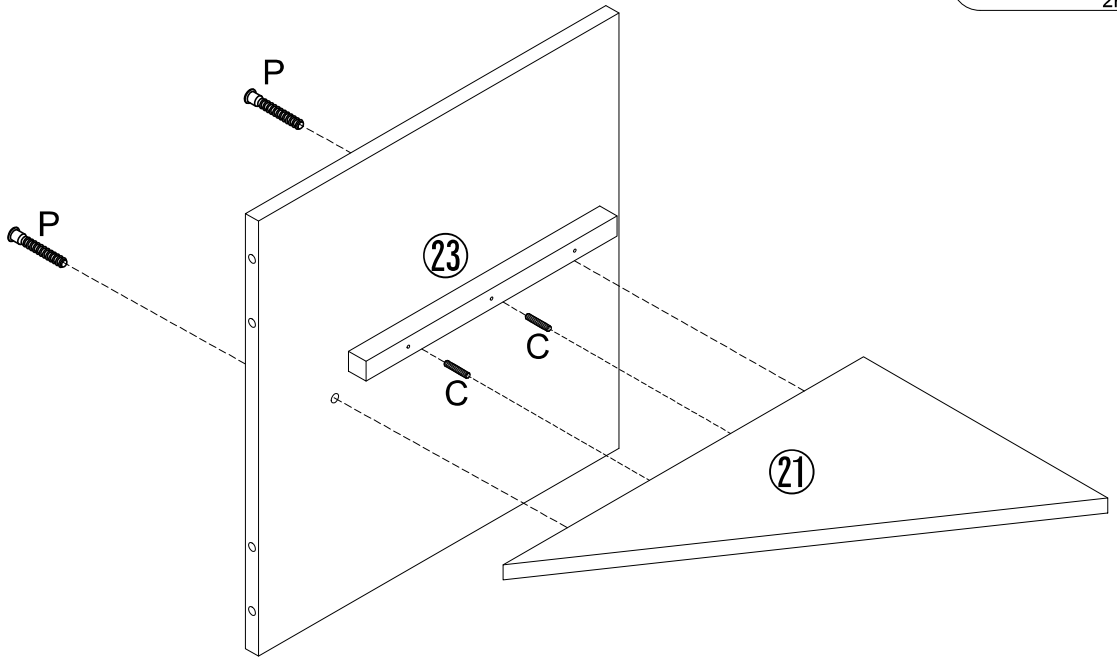

7

- B 2PCS
8*40
- C 3PCS
8*40
- P 2PCS
8*40

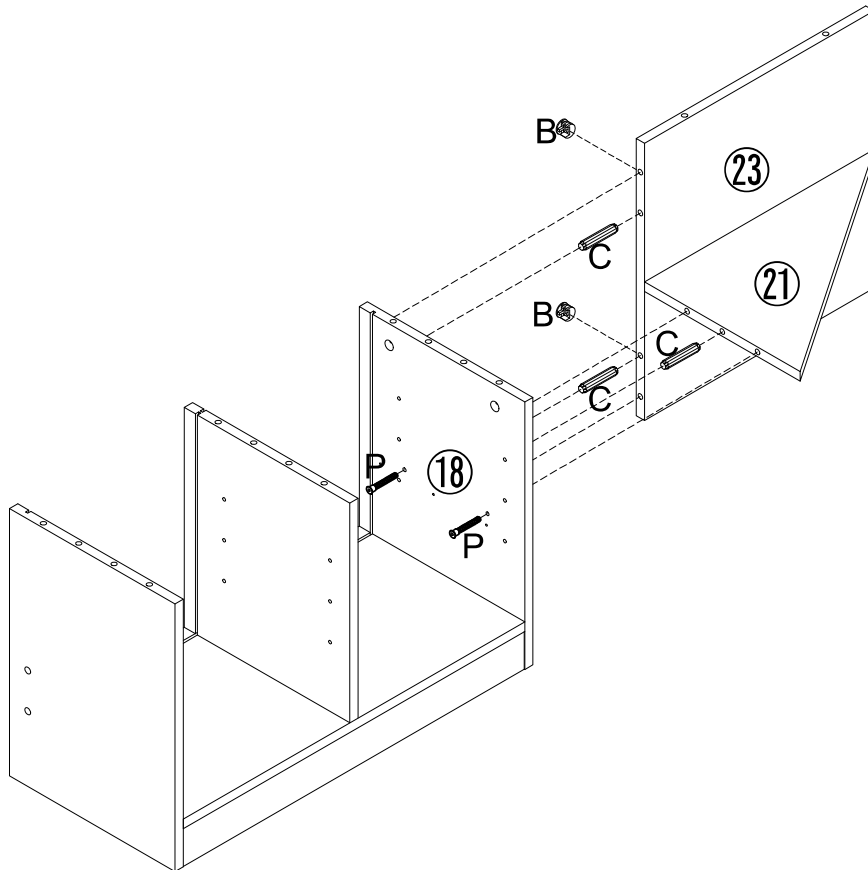
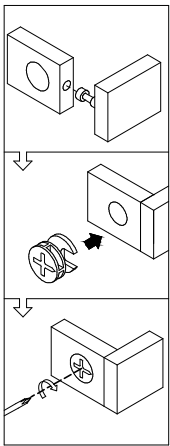

8

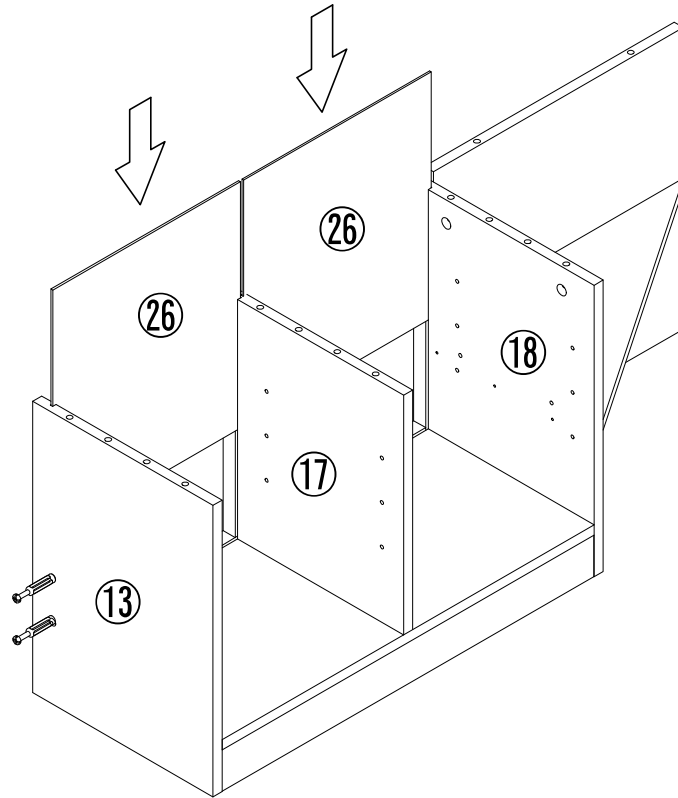

9

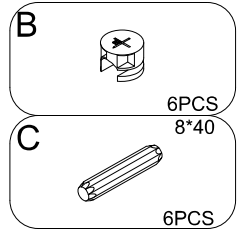
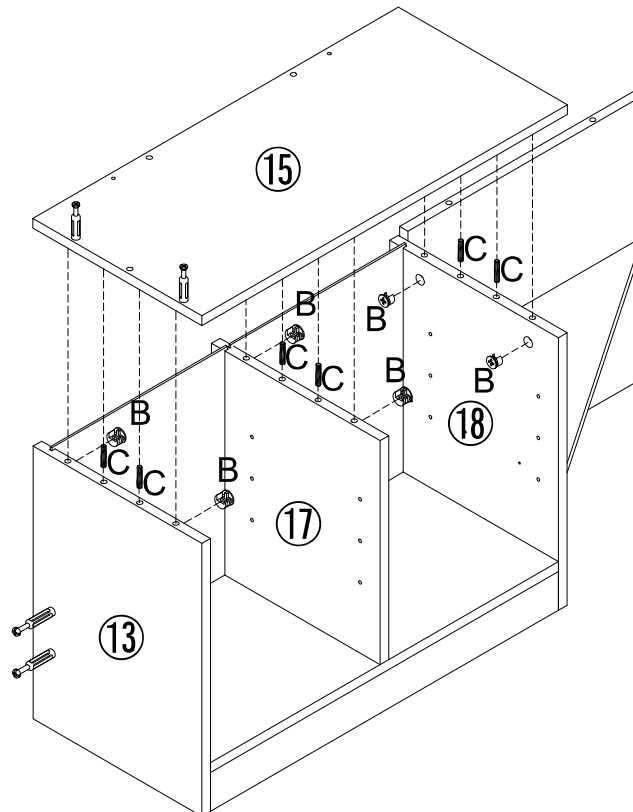
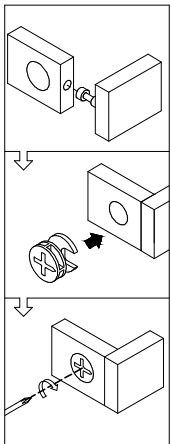

10

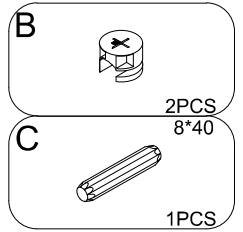
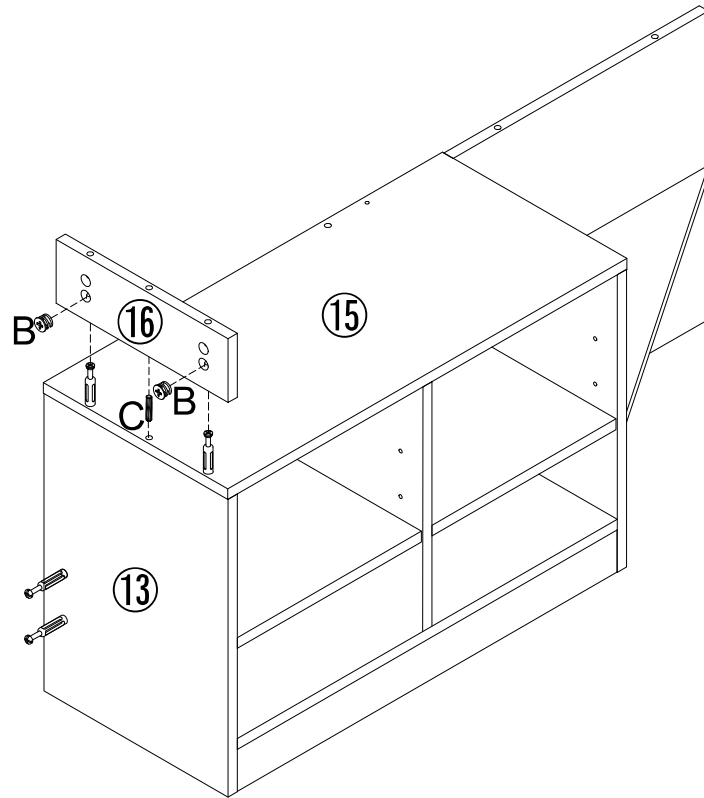
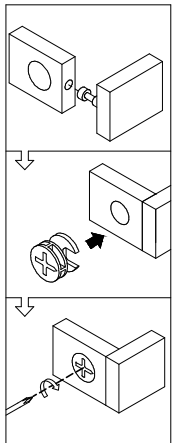

11

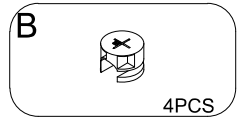
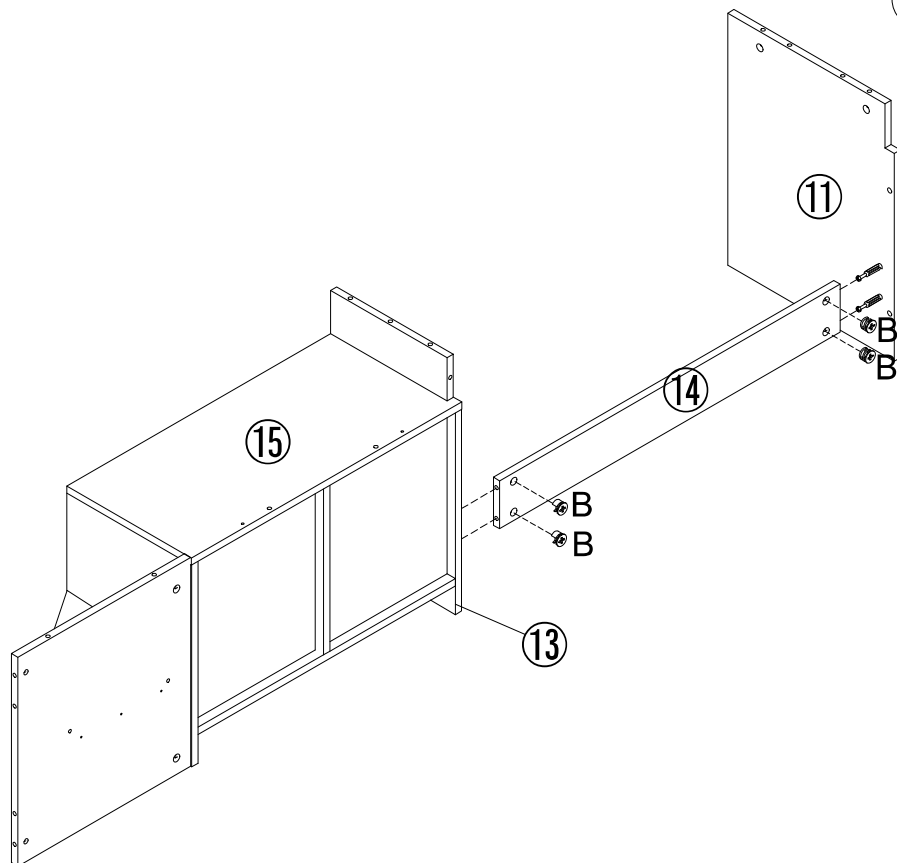
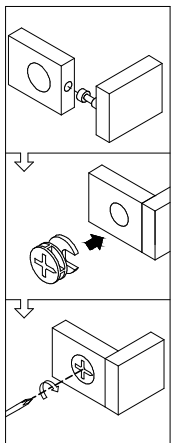

- C 8*40
4PCS
- P 7*50
3PCS

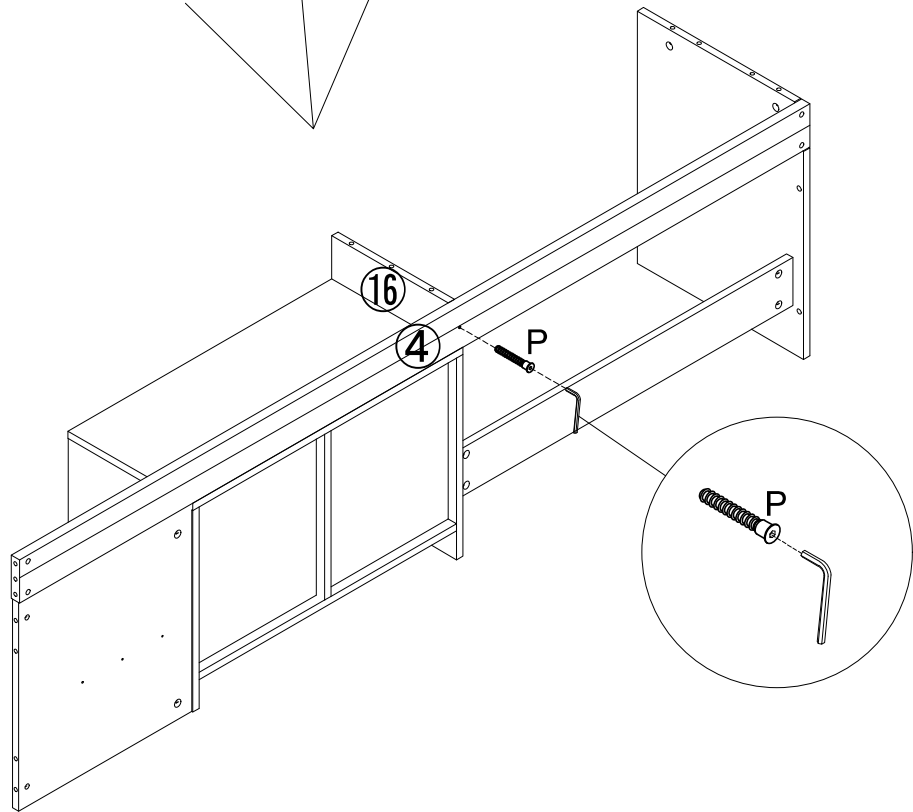
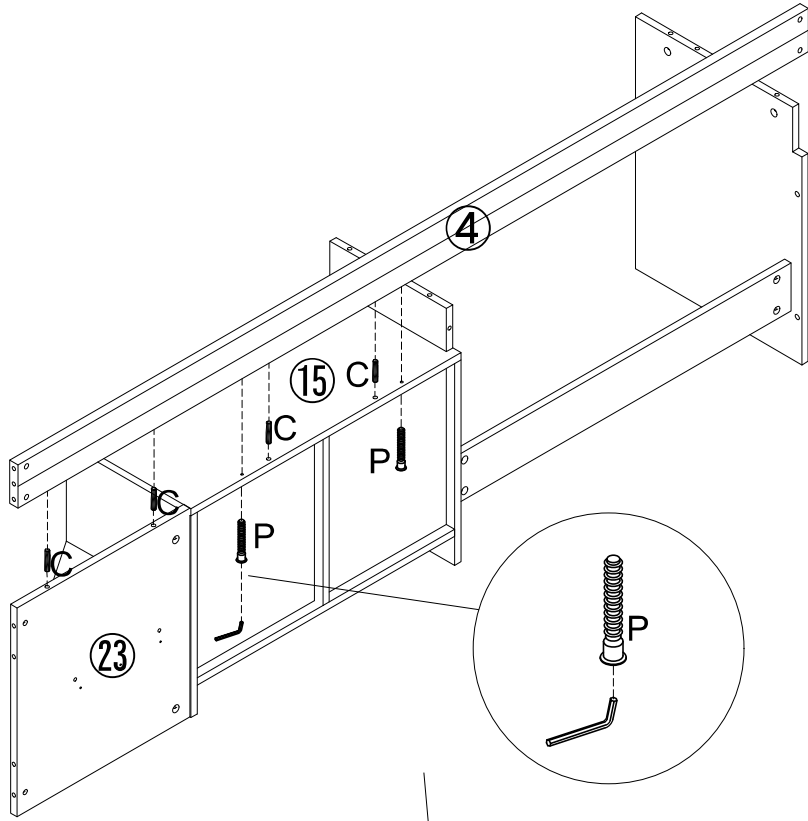

13

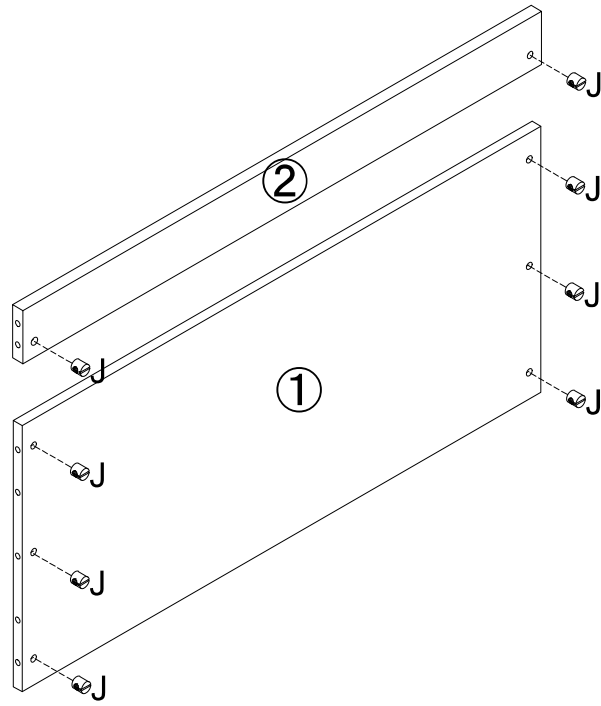

- C 8*40
6PCS
- H 6*70
8PCS
- J
8PCS

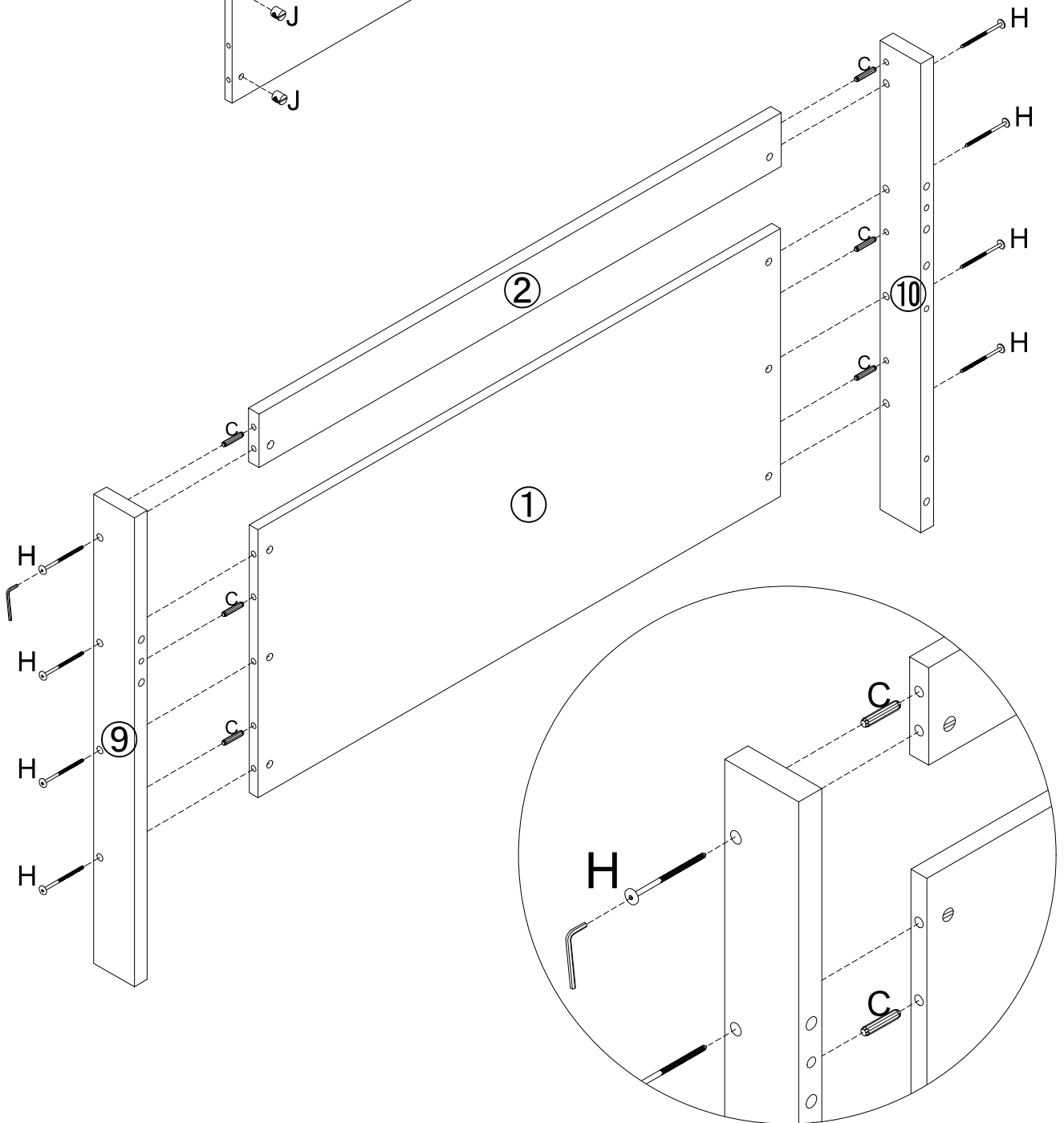

14

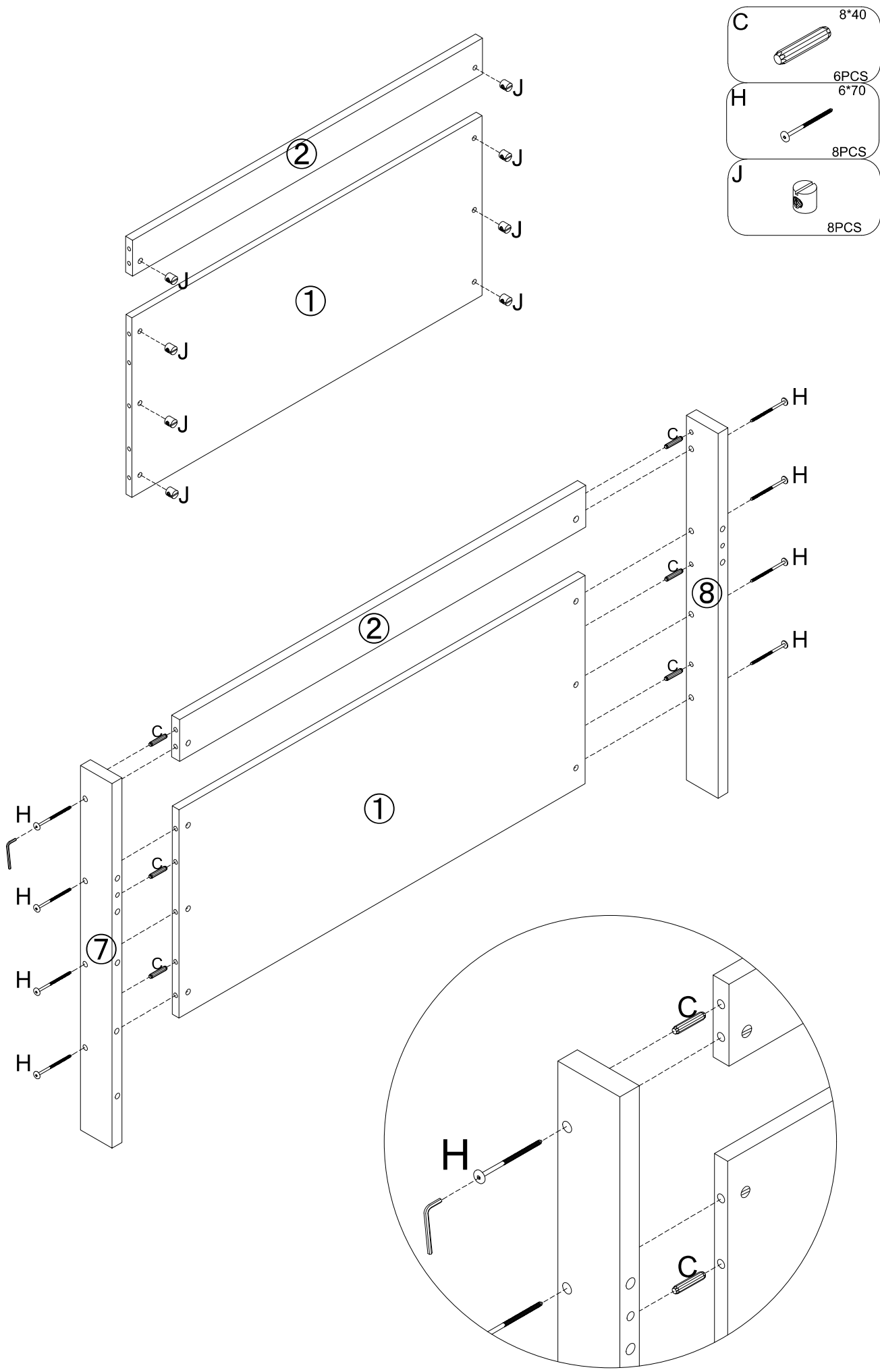

15

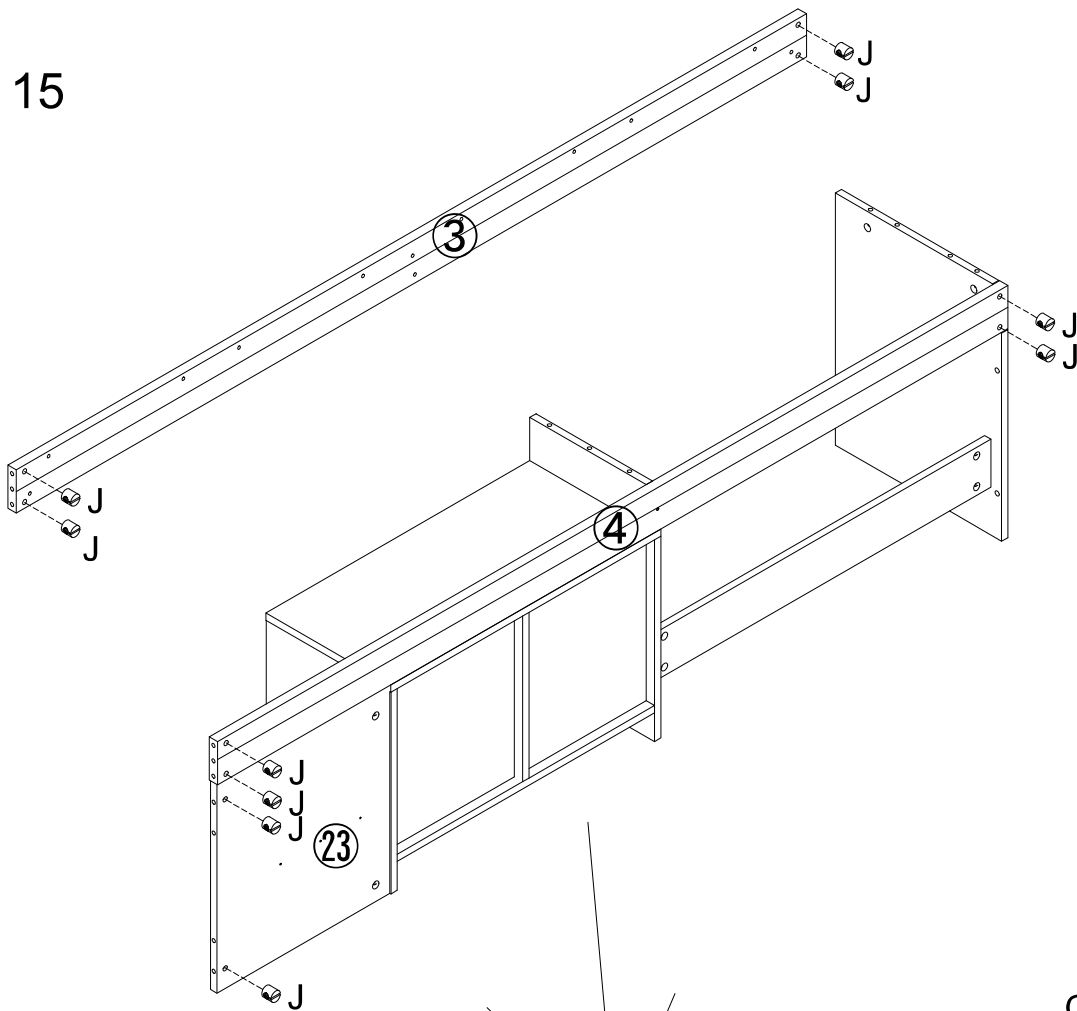



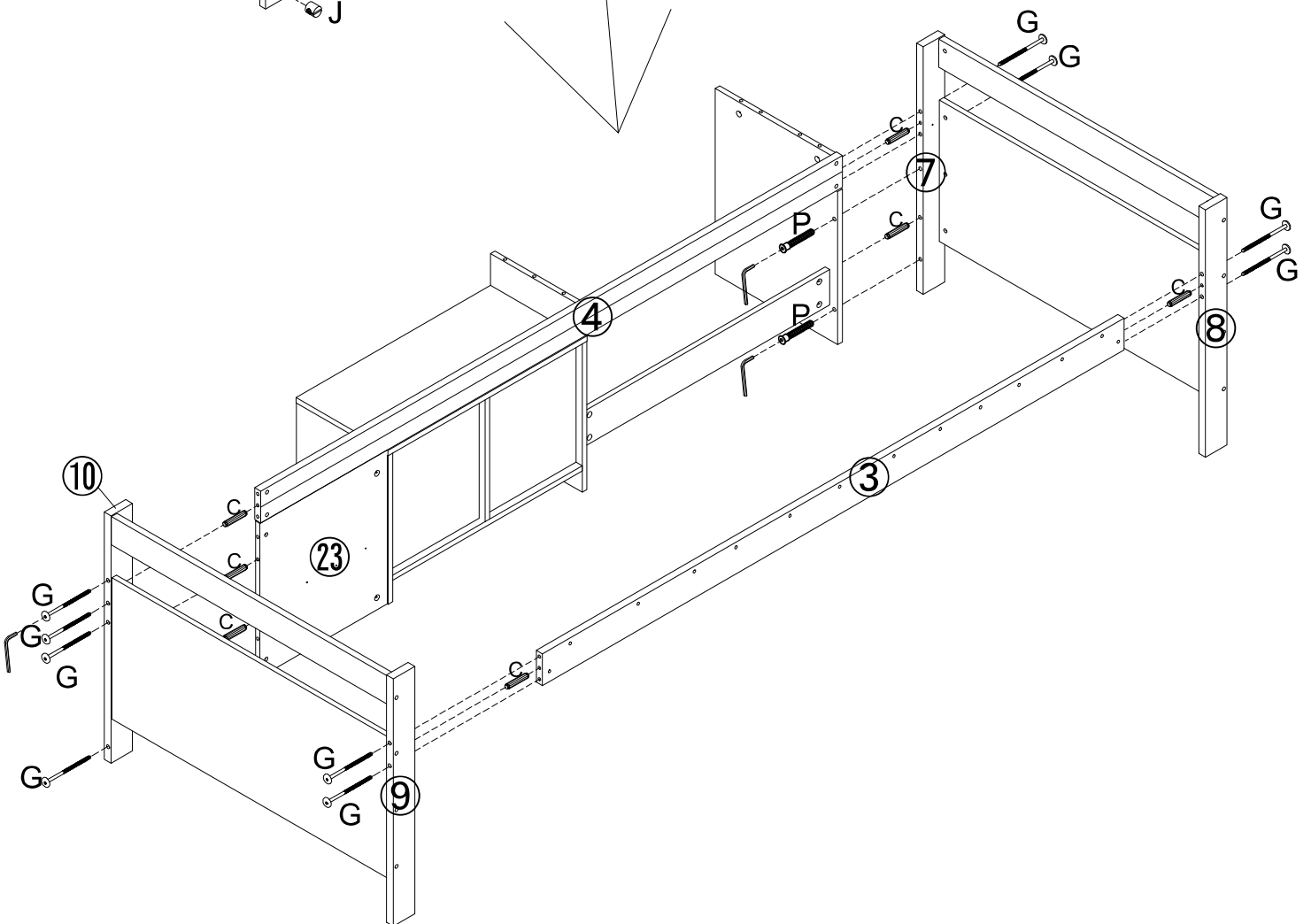

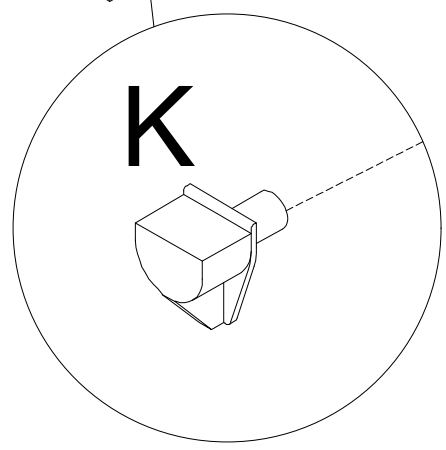
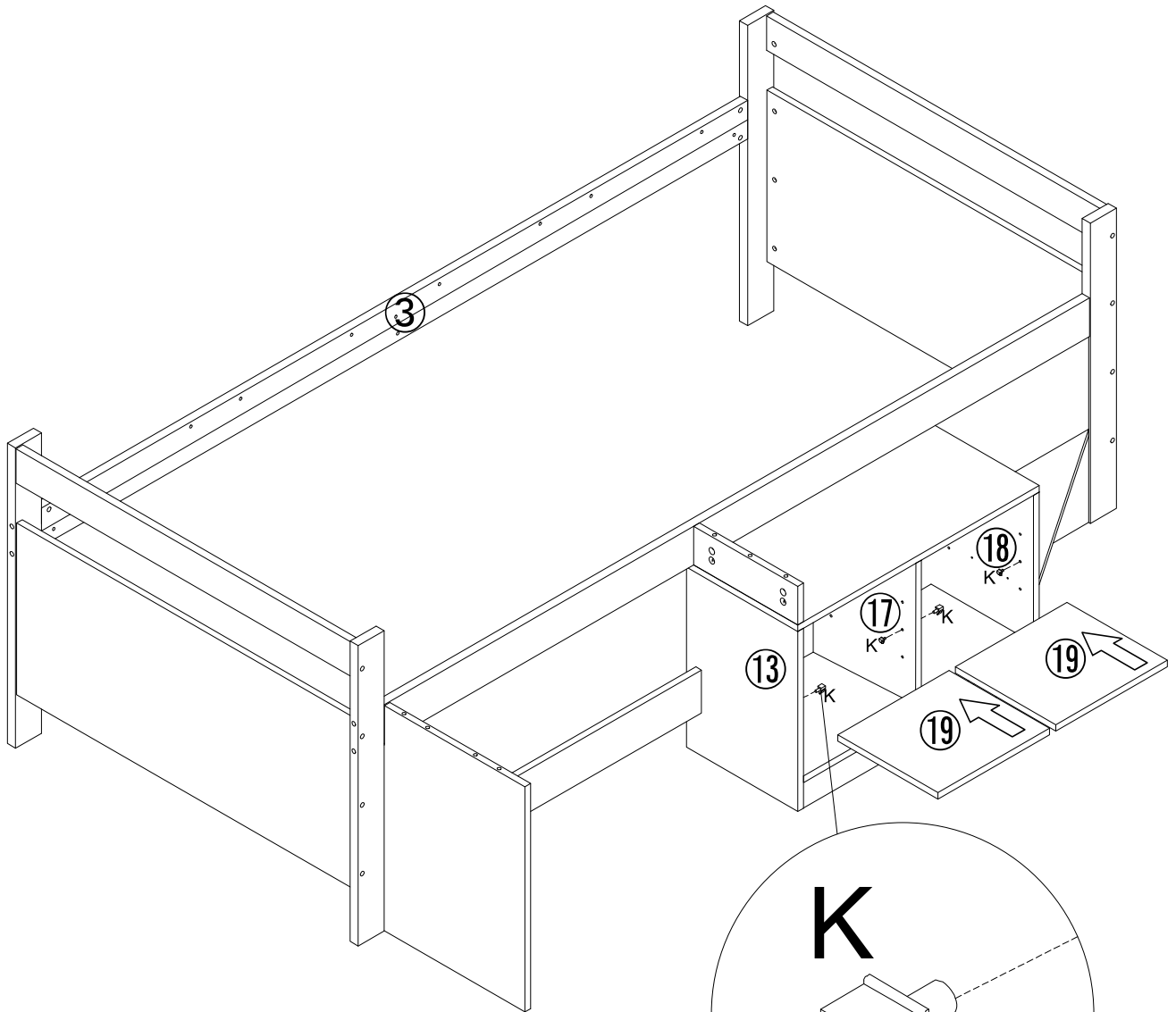
- C** 8*40
7PCS
- G** 6*120
10PCS
- J**
10PCS
- P** 7*50
2PCS



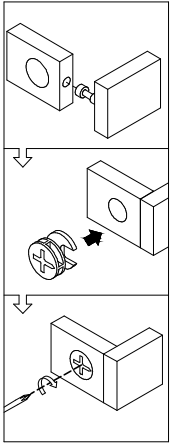

17



- B**  4PCS
8*40
- C**  3PCS
3.5*14
- D**  2PCS
- F**  1PCS

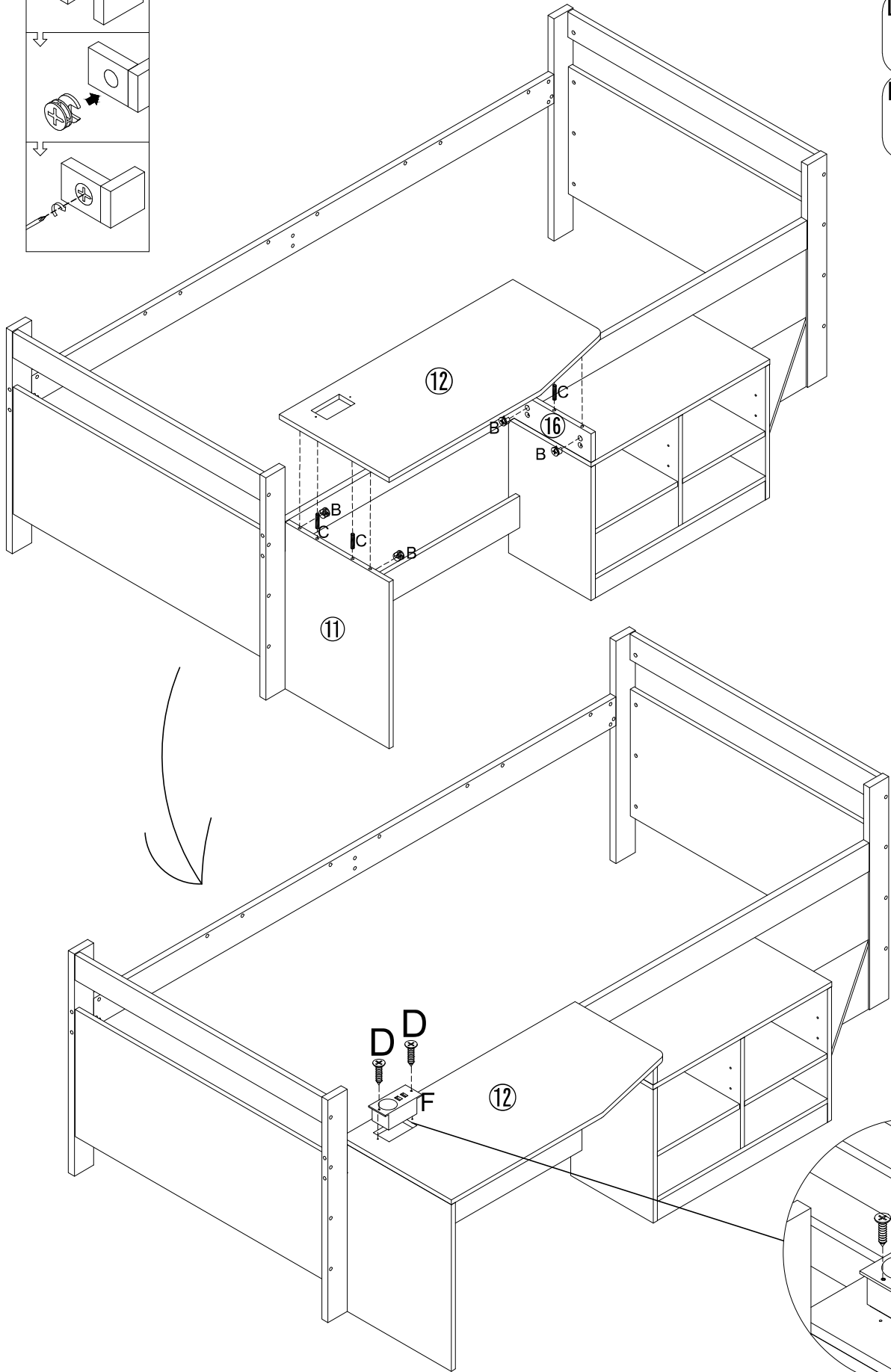

18

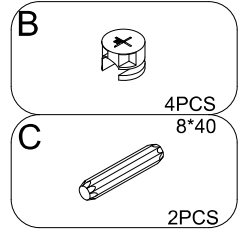
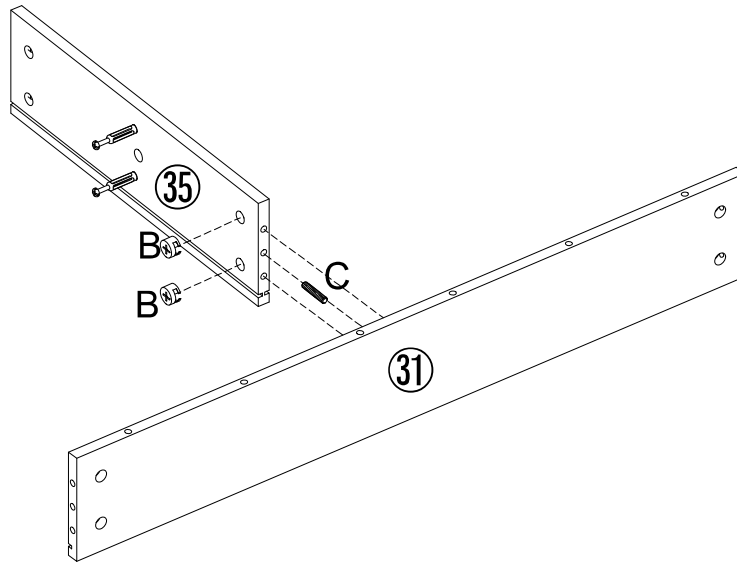
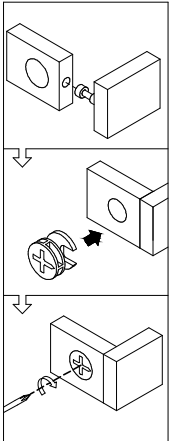

X2

19

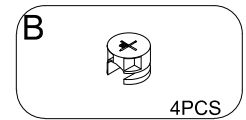
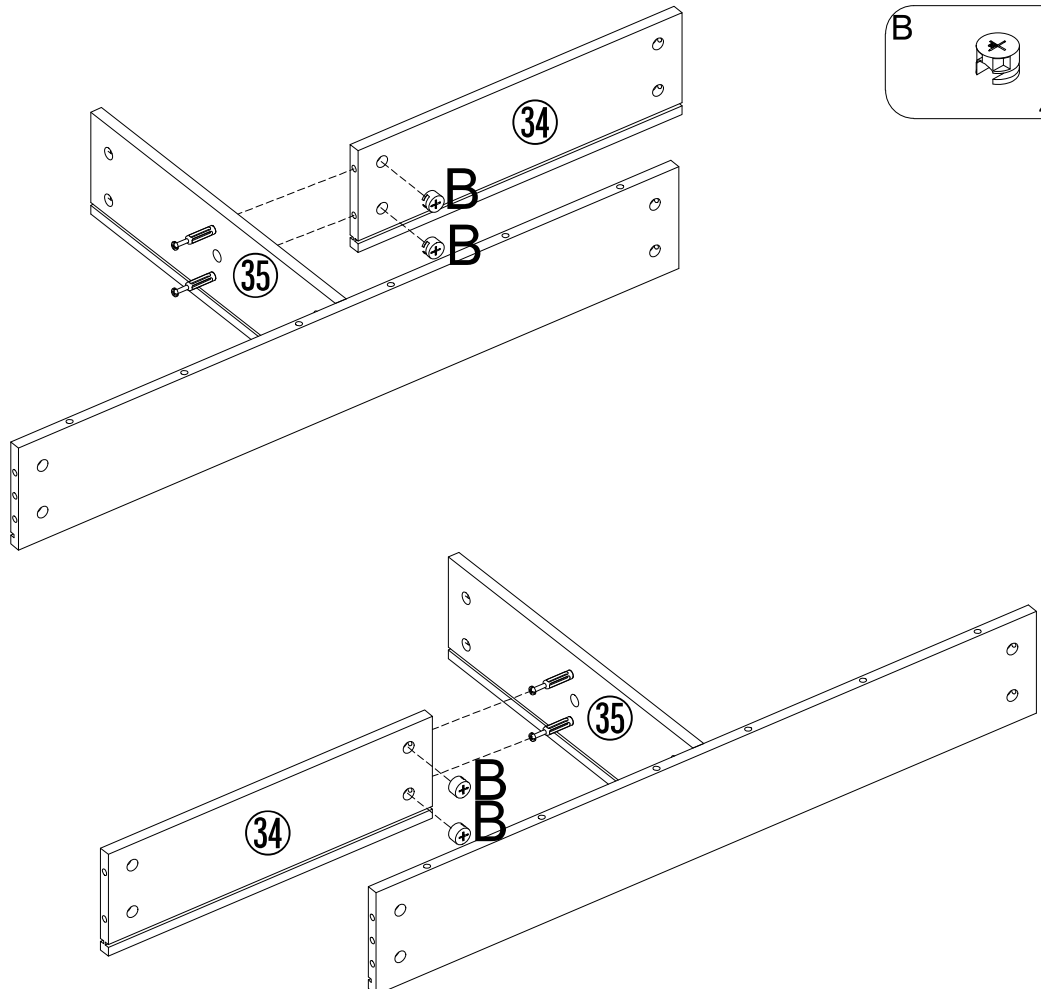
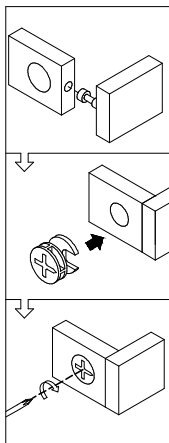

20

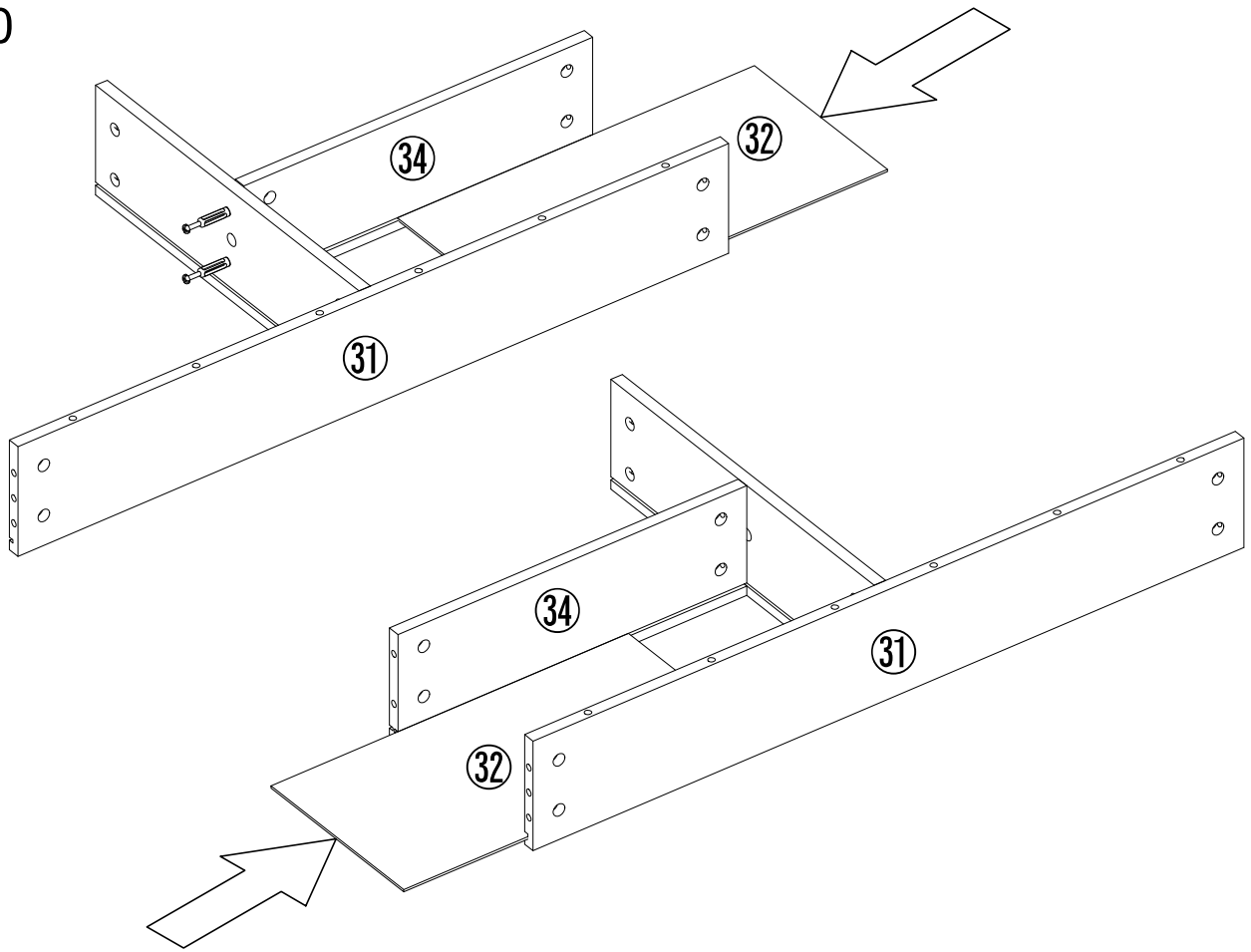

21

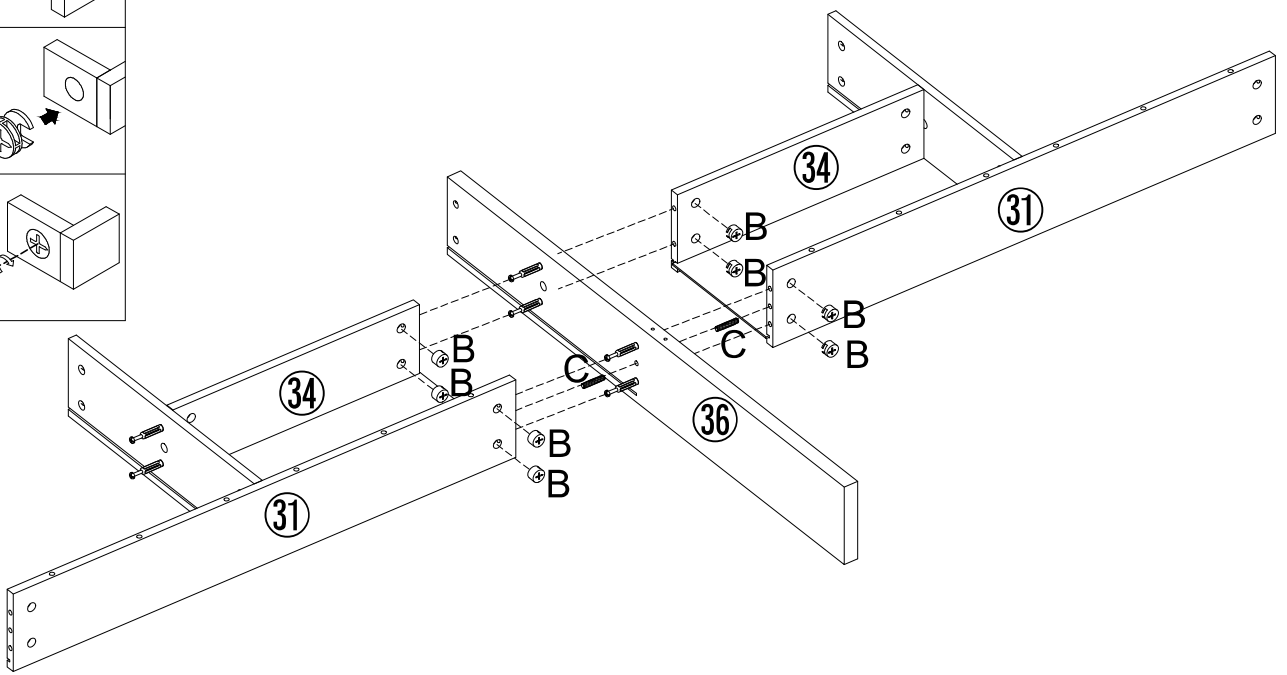
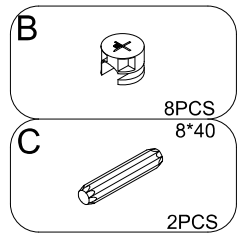
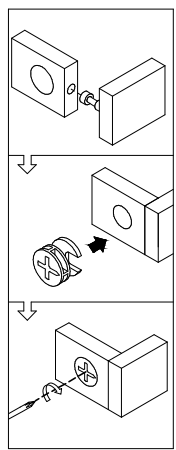

22

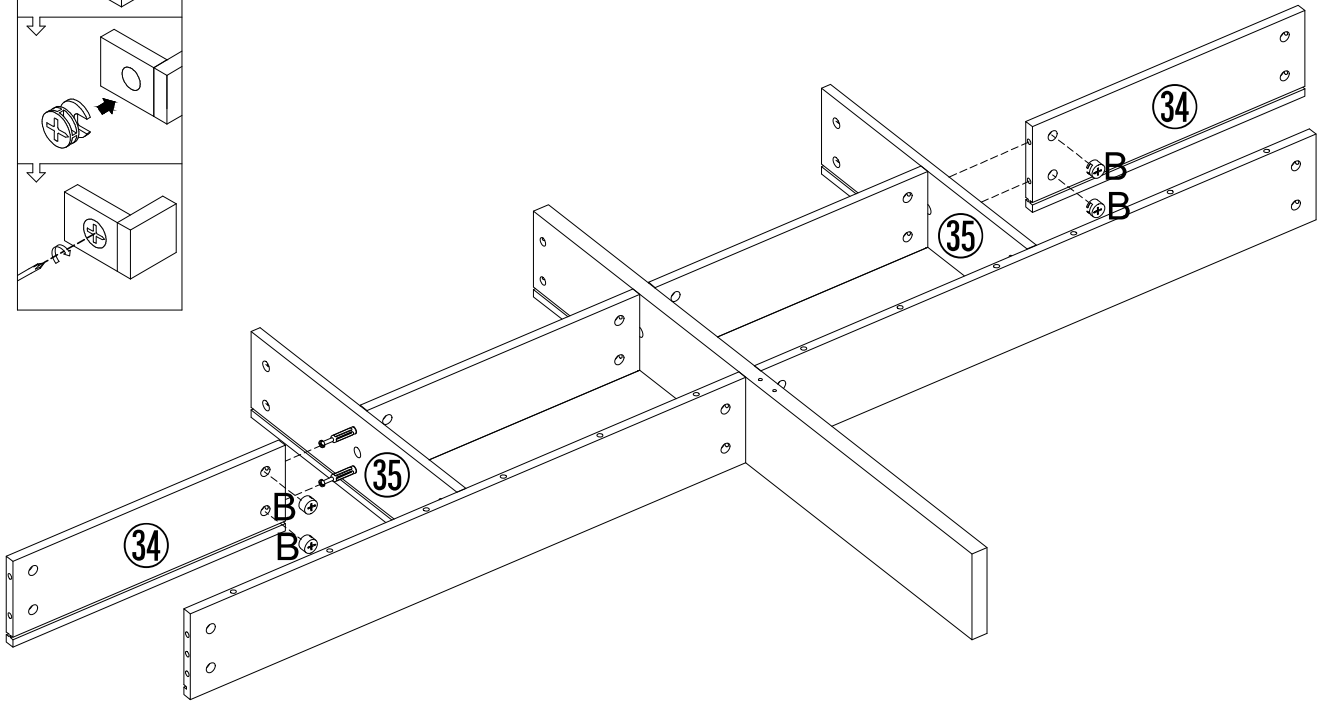
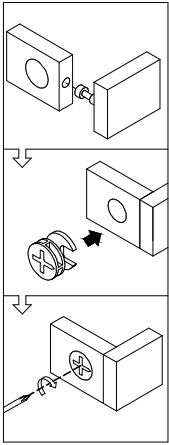
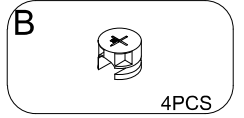

23

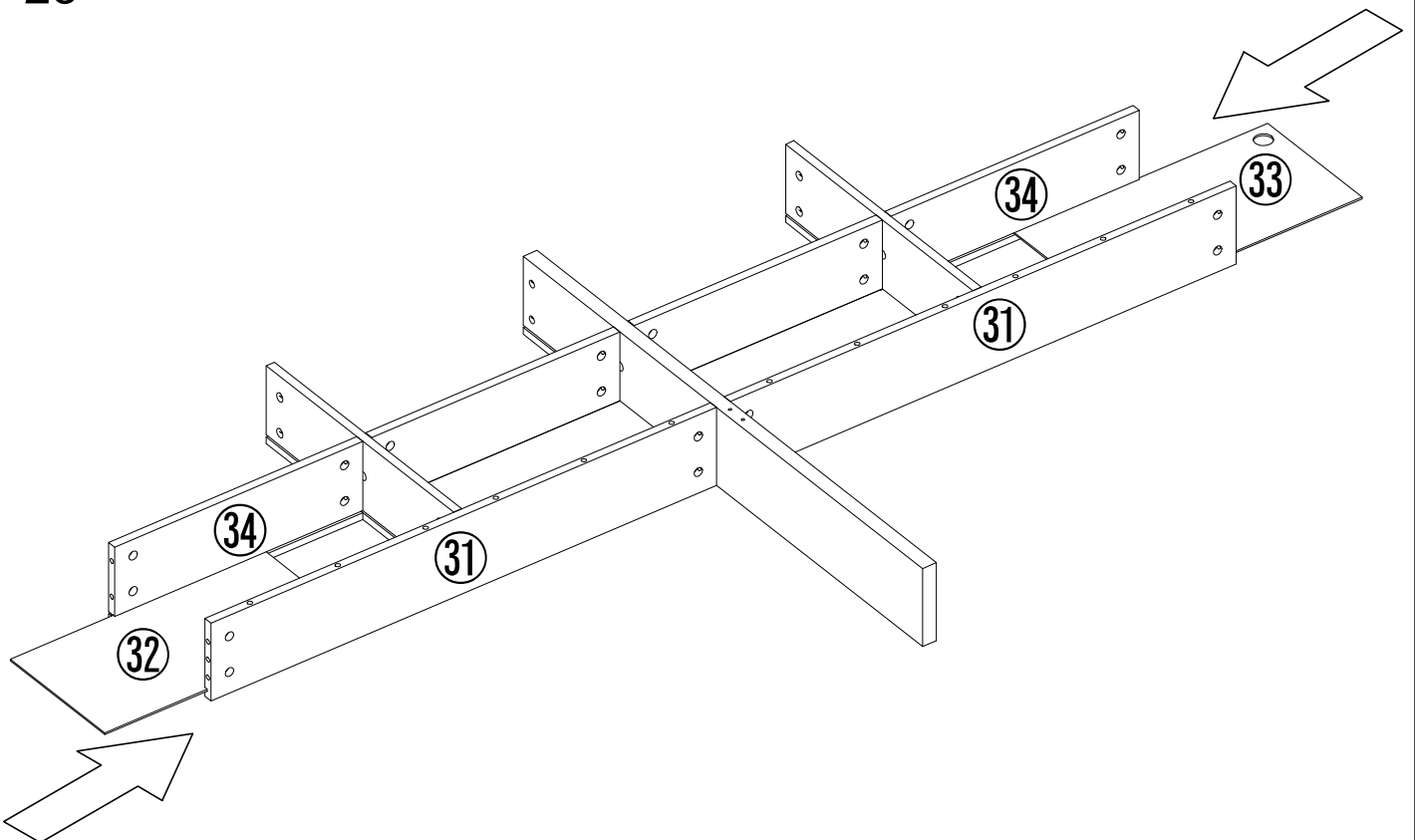

DE: Reißen Sie den blauen Aufkleber auf der Rückseite des Lichtstreifens ab und platzieren Sie den LED-Lichtstreifen an der Unterseite der Platine ③④

EN: Tear off the blue sticker on the back of the light strip and place the LED light strip at the bottom of the board ③④

FR: Détachez l'autocollant bleu au dos de la bande lumineuse et placez la bande lumineuse LED au bas de la carte ③④

IT: Staccare l'adesivo blu sul retro della striscia luminosa e posizionare la striscia luminosa a LED nella parte inferiore della scheda ③④

ES: Quite la etiqueta azul de la parte posterior de la tira de luz y coloque la tira de luz LED en la parte inferior del tablero ③④

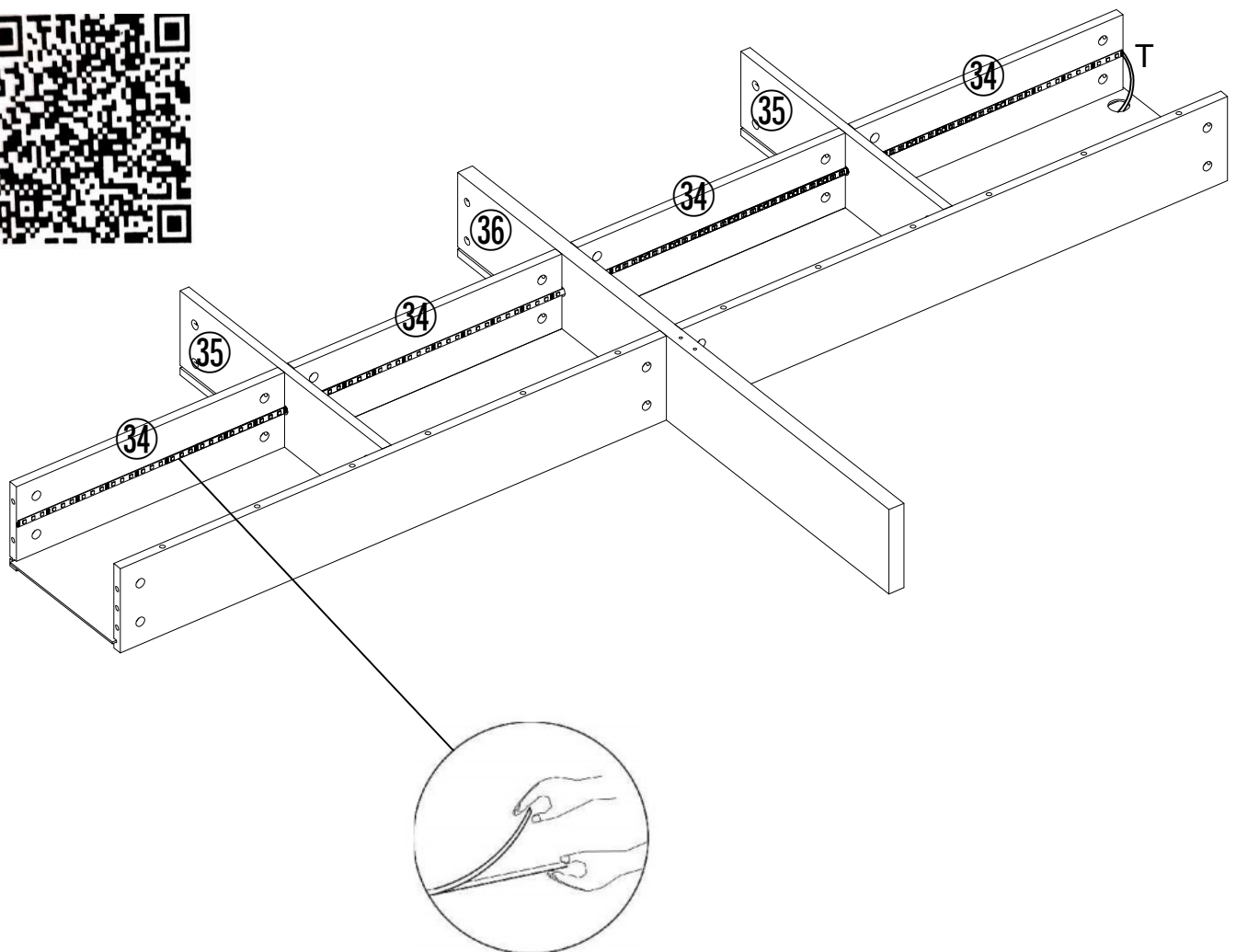

EN: Scan to download App control the Led light.

DE: Scannen, um die App zum Steuern des LED-Lichts herunterzuladen

FR: Scanner pour télécharger App contrôler la lumière Led.

ES: Analice para descargar la aplicación control de la luz Led.

IT: Scansiona per scaricare l'applicazione controlla la luce Led.

25

B  8PCS
8*40

C  2PCS

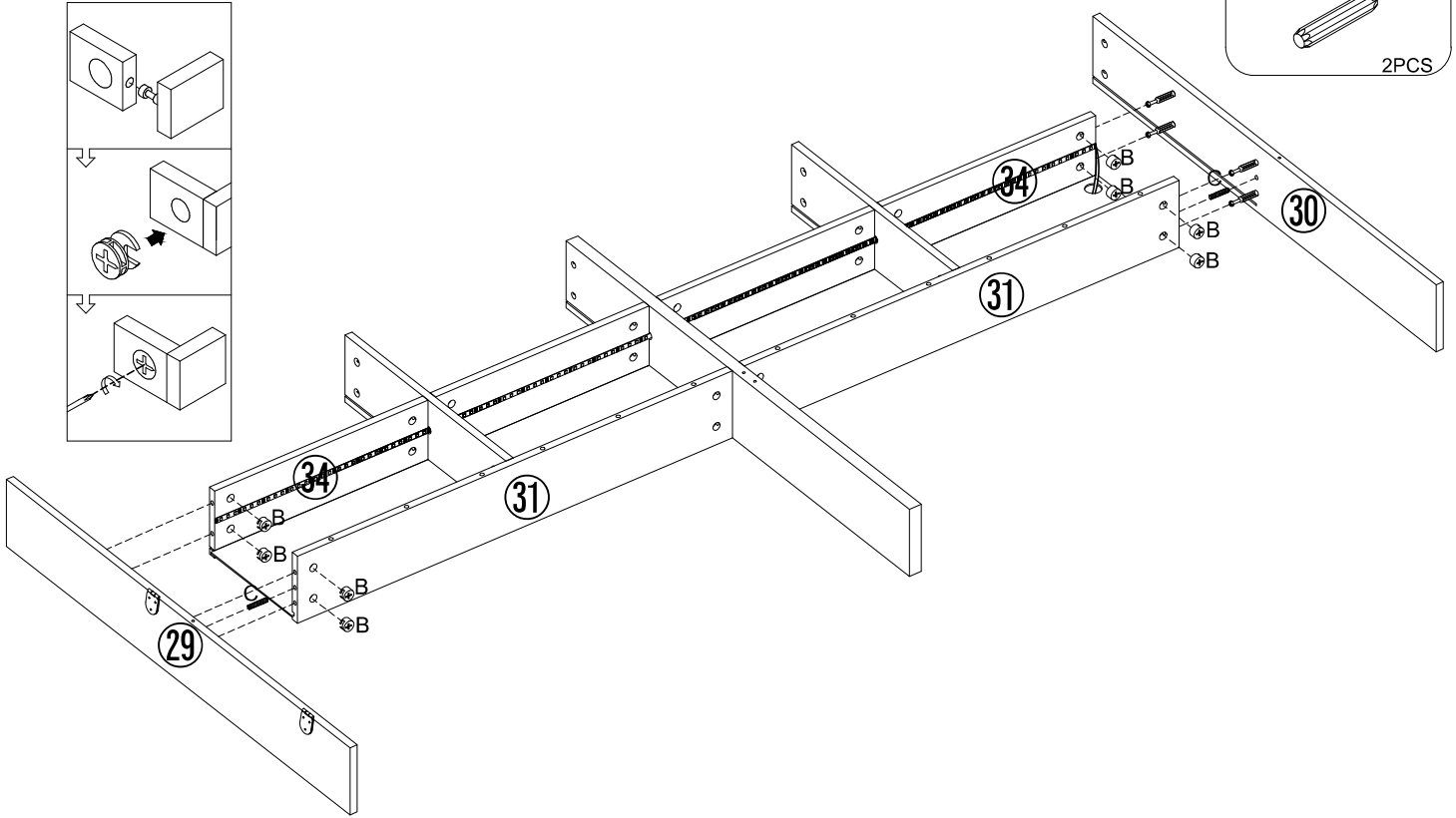

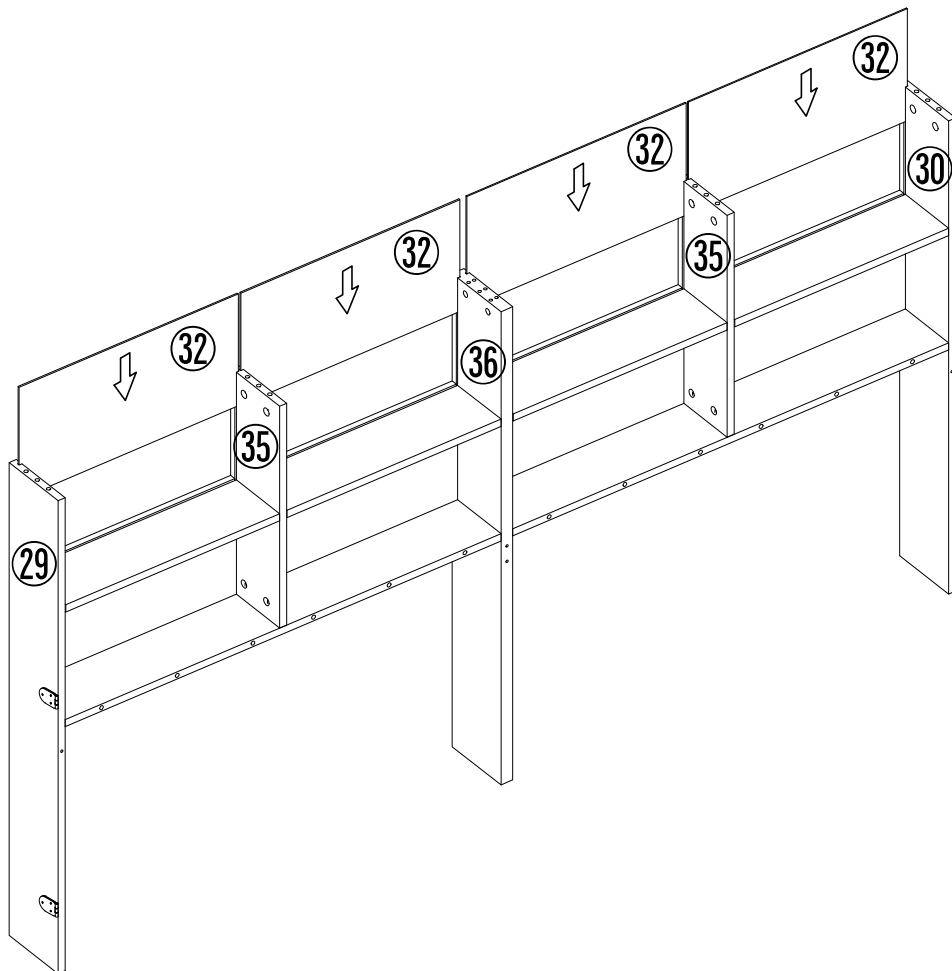

26



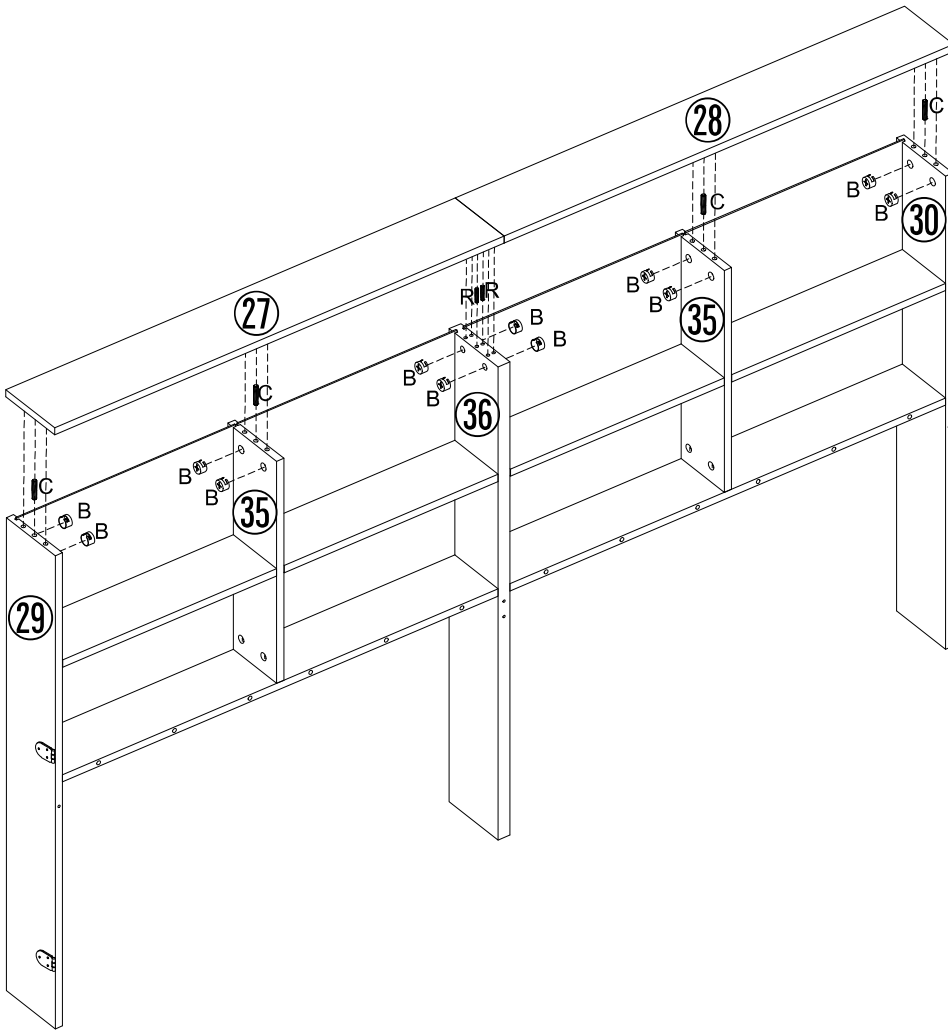
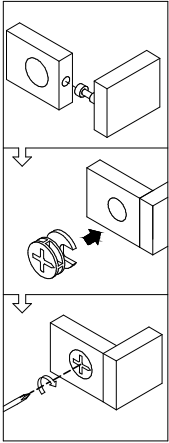

27

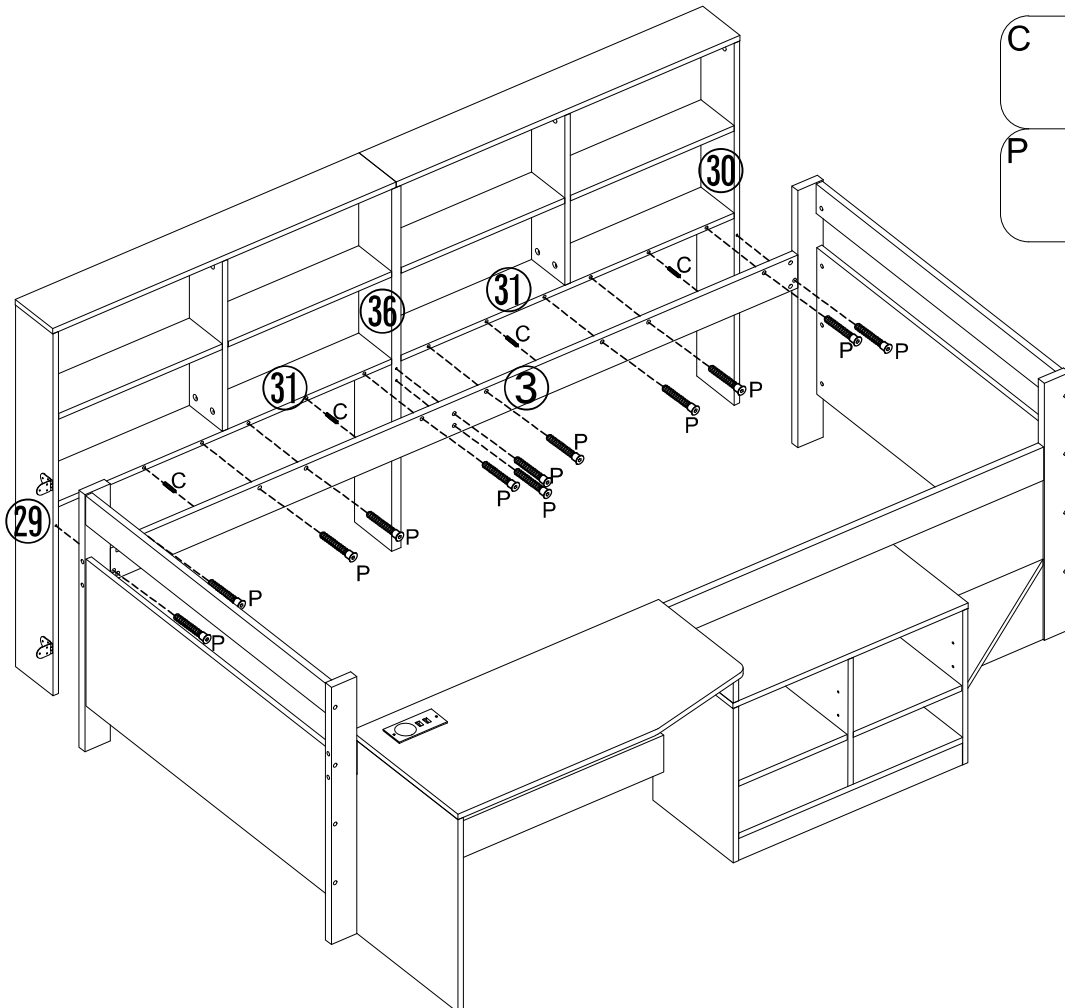

- B**  12PCS 8*40
- C**  4PCS 6*30
- R**  2PCS 6*30

28



- C**  4PCS 8*40
- P**  12PCS 7*50

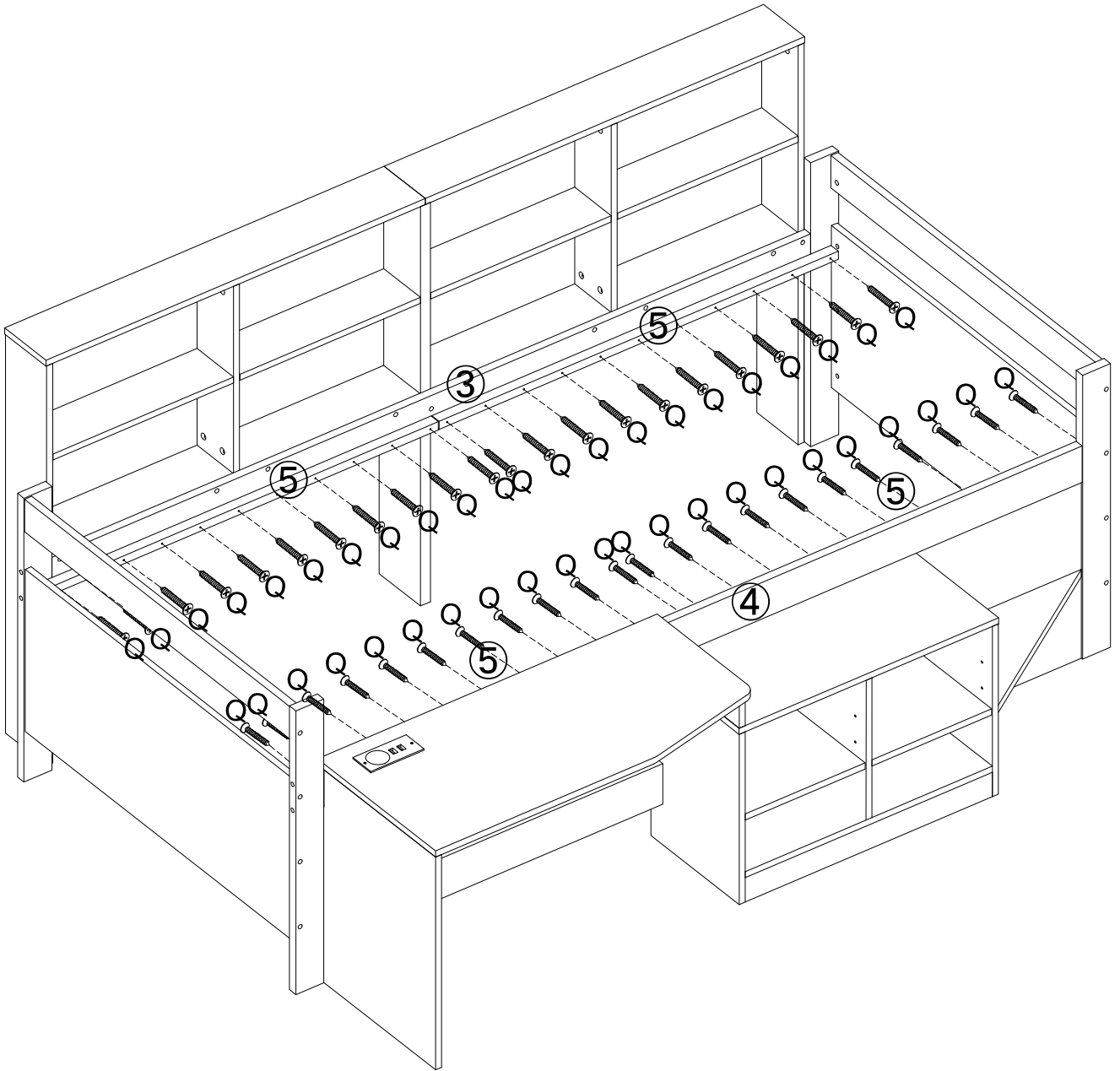

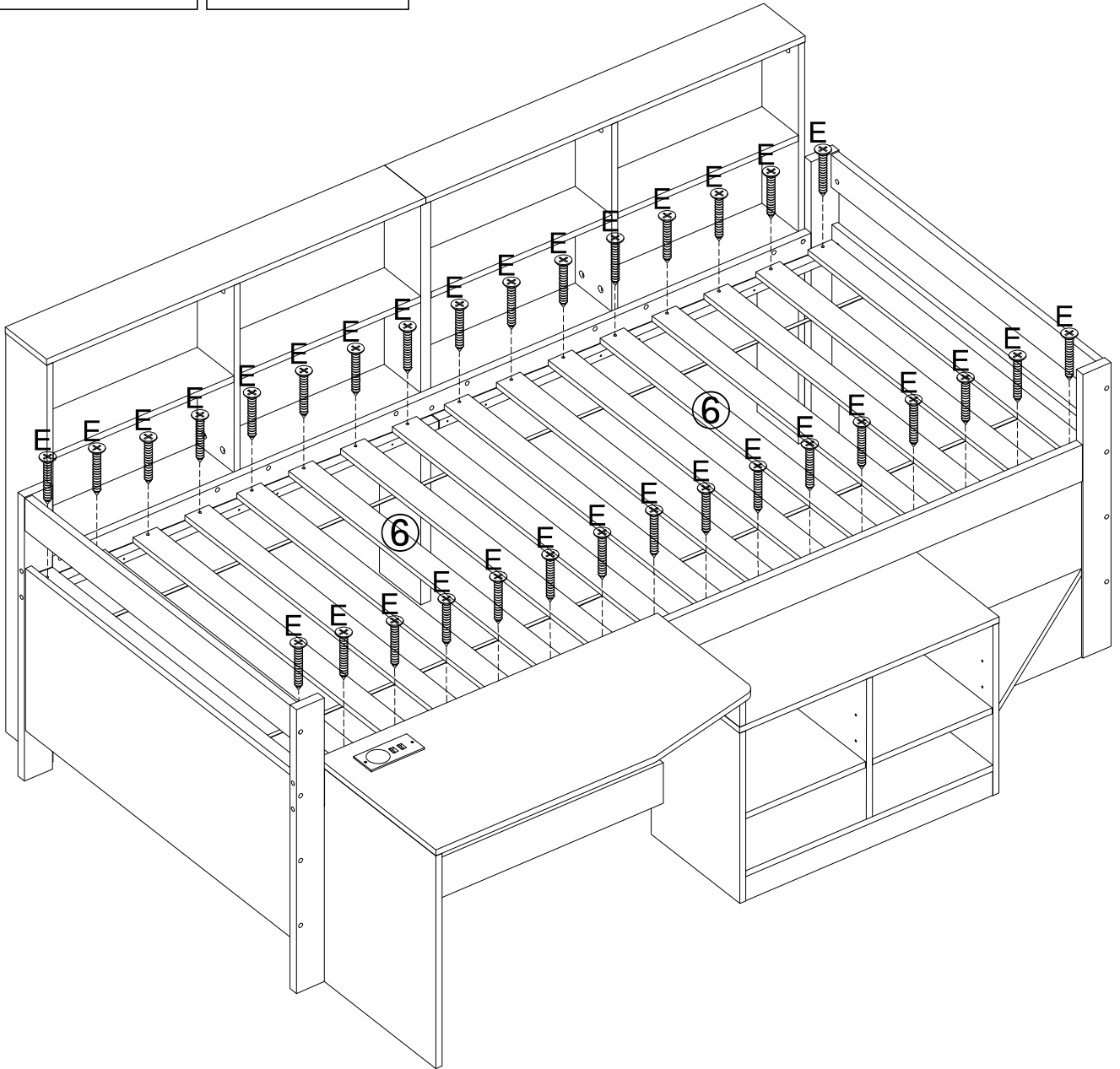
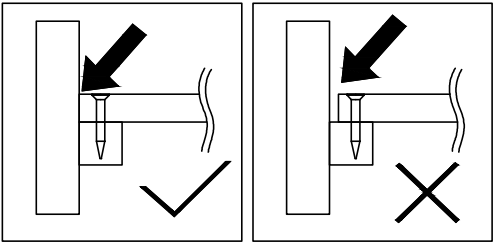



UK: After installing the product, stick the number L on the perforated position

FR: Une fois le produit installé, collez le numéro L à l'endroit où il ya des trous

DE: Nach der Installation des Produkts kleben Sie die Nummer L auf die perforierte Position

IT: Dopo l'installazione del prodotto, fissare il numero L sulla posizione perforata

ES: Después de instalar el producto, pegue el número L en la posición perforada

U	3.5*14
	40PCS
W	
	32PCS
L	
	54PCS

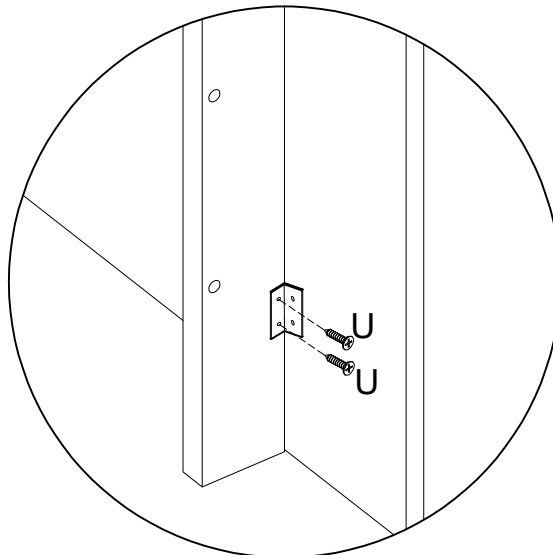
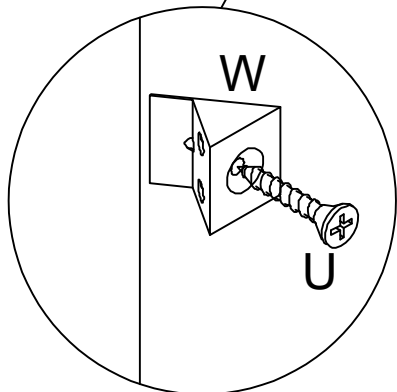
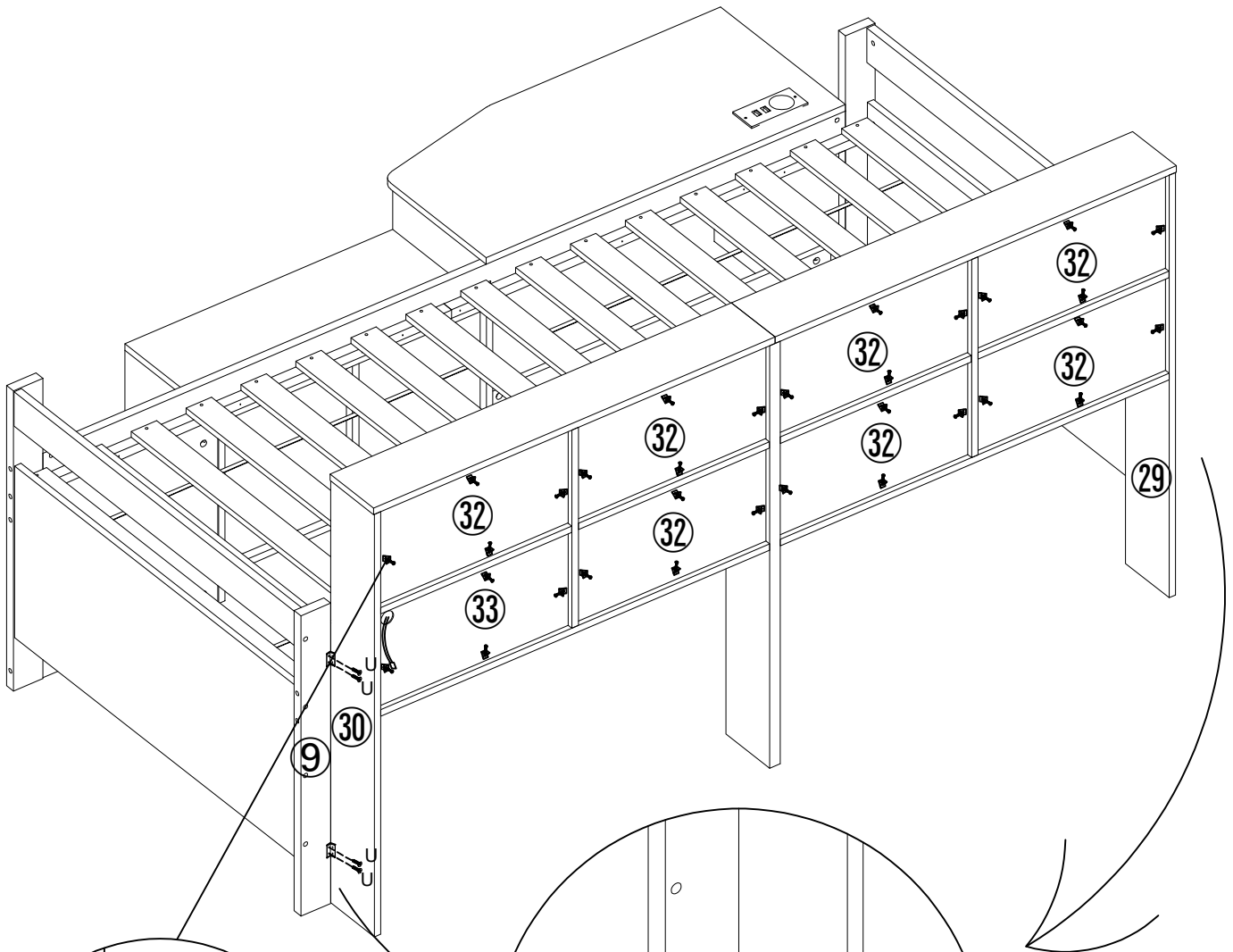
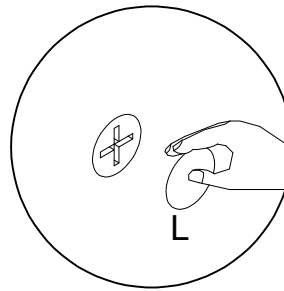

①



②



③



④



⑤



⑥



⑦



⑧



APP-PROGRAMMANWENDUNG

Klicken, um
Lampenliste
anzuzeigen
Farbrad
wechseln



Klicken für
Einstellungsansicht

Farbe anpassen

Farbanpassung
per Quadrat-
Symbol

Schnittstelle
durch Klicken
wechseln



HINWEIS:

Detaillierte Anleitung im
Menü "Guide"

PRODUKTPARAMETER

- Bluetooth: BLEVA 2
- Eingangsspannung: 4.5~26V
- Betriebstemperatur: -25~75 ° C
- Abmessungen: 43×22×11 mm
- Gewicht: 30g
- Max. Leistung: 144W (24V)

VERBINDUNGSSCHRITTE

- ① LED-Farbstreifen & Controller verbinden, Controller einschalten
- ② QR-Code scannen zum App-Download:



- ③ App starten, Controller suchen & verbinden
- ④ Bluetooth-Drahtlossteuerung genießen

PRODUKTMERKMALE

- Direkte Handy-Steuerung (20m Reichweite)
- Automatische Verbindung in 5 Sekunden
- Musikrhythmus-Synchronisation
- Gruppensteuerung
- Helligkeits-/Geschwindigkeitsregelung
- Unterstützt bis 10m RGB(W)-Streifen
- Automatische Sprachumschaltung (DE/EN)

ANIMATIONSEFFEKTE

- Farbverläufe
- Einfarbige/ Zweifarbige Gradienten
- Monochrome/Bunte Blinkereffekte
- Farbspringen
- Musikresponsive Effekte

APP PROGRAM USAGE



- Scan two-dimensional code download APP
- ①Connect LED color strip and controller, power on controller
 - ②Scan two-dimensional code download APP:



- ③Start APP, search and connect controller
- ④Enjoy the Bluetooth wireless control experience



Notes:
detailed operating instructions,
enter the menu "Guide":

Product Paramters:

- Bluetooth:BLEV4.2
- Input Voltage:4.5~26V
- Working Temp:-25~75°C
- Size:43*22*11mm
- Weight:30g
- Max Power:144W (24V)

LED mobile phone Bluetooth controllerProduct Features

- LED Bluetooth controller is directly via mobilephone control remote distance can reach 20m without the need to setupeasy to connect open the software within 5 seconds you can automatically connect the controller
- Flow the rhythm of the music changes
- Group control
- Brightness, speed addition and subtraction
- Maximum can be 10 meters RGB(W) strip
- The software shows that the text is based onthe language of the mobile phone set up automatic transformation of Chinese and English

ANIMATION EFFECTS:

- Colorful gradient
- All kinds of monochrome, double color gradient
- All kinds of monochrome, double color, colorfull flashing
- Colorful jump
- Follow the thymhm of the music chagnes

APP-PROGRAMMANWENDUNG

Afficher la
liste des lampes
Farbrad
Changer la
Roue chromatique



Afficher les
paramètres

Ajuster la couleur

Cliquez sur l'icône
carrée pour ajuster
la couleur.

Changer d'
interface
par clic



REMARQUE :

Guide détaillé dans le menu
"Guide"

CARACTÉRISTIQUES

- Bluetooth : BLEVA 2
- Tension d'entrée : 4.5~26V
- Température : -25~75° C
- Dimensions : 43×22×11 mm
- Poids : 30g
- Puissance max : 144W (24V)

ÉTAPES DE CONNEXION

- ① Connecter bande LED & contrôleur, allumer
- ② Scanner QR code pour télécharger l'app :



- ③ Lancer l'app, rechercher & connecter
- ④ Profiter du contrôle Bluetooth sans fil

FONCTIONNALITÉS

- Contrôle direct par smartphone (20m)
- Connexion automatique en 5 secondes
- Synchronisation musicale
- Contrôle de groupe
- Réglage luminosité/vitesse
- Prise en charge bandes ≤10m RGB(W)
- Basculement automatique FR/EN

EFFETS D'ANIMATION

- Dégradés de couleurs
- Dégradés uni/bicolores
- Clignotements mono/colorés
- Saut de couleurs
- Effets réactifs à la musique

UTILIZZO APP



PASSI CONNESSIONE

- ① Collega striscia LED & controller, accendi
- ② Scansiona QR code per scaricare APP:



- ③ Avvia APP, cerca & connetti controller
- ④ Goditi controllo wireless Bluetooth



NOTA:

Guida completa nel menu "Guide"

SPECIFICHE:

- Bluetooth: BLEVA 2
- Tensione ingresso: 4.5~26V
- Temperatura: -25~75° C
- Dimensioni: 43×22×11 mm
- Peso: 30g
- Potenza max: 144W (24V)

CARATTERISTICHE

- Controllo diretto smartphone (20m)
- Connessione automatica in 5 secondi
- Sincronizzazione ritmo musicale
- Controllo di gruppo
- Regolazione luminosità/velocità
- Supporto strisce ≤10m RGB(W)
- Auto switch IT/EN

EFFETTI ANIMAZIONE:

- Sfumature colore
- Gradienti mono/bicolori
- Luci lampeggianti mono/colorate
- Salto colori
- Effetti reattivi alla musica

USO DE LA APLICACIÓN

Mostrar lista de _____
Lámparas
Cambiar rueda de color

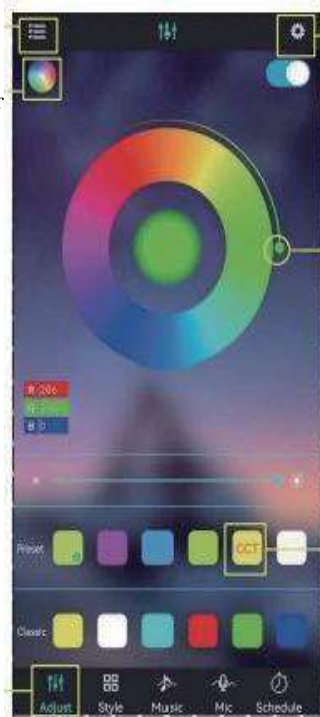

Ver ajustes

Ajustar el color

Clic Ajustar color
con icono cuadrado

Cambiar interfaz
haciendo clic _____



NOTA:

Guía completa en menú "Guide"

ESPECIFICACIONES:

- Bluetooth: BLEVA 2
- Voltaje entrada: 4.5~26V
- Temperatura: -25~75° C
- Tamaño: 43×22×11 mm
- Peso: 30g
- Potencia máx: 144W (24V)

PASOS DE CONEXIÓN

- ① Conectar tira LED y controlador, encender
- ② Escanear QR para descargar APP:



- ③ Iniciar APP, buscar y conectar
- ④ Disfrutar control inalámbrico Bluetooth

CARACTERÍSTICAS

- Control directo móvil (20m alcance)
- Conexión automática en 5 segundos
- Sincronización ritmo musical
- Control grupal
- Ajuste brillo/velocidad
- Soporte tiras ≤10m RGB(W)
- Auto cambio ES/EN

EFFECTOS DE ANIMACIÓN:

- Degradados de color
- Transiciones mono/bicolores
- Destellos monocromáticos/color
- Salto de colores
- Efectos reactivos a música

Verification of Compliance

Verification No.:	MK25050138P01-E01
Name and address of Applicant:	Dongguan Jingdeli Intelligent Technology Co.,Ltd. Room 202,Building 3,No.28, Dongkeng Town Yanhe West 1st Road, Dongkeng Town, Dongguan,523000, Guangdong,China
Name and address of Manufacturer:	Dongguan Jingdeli Intelligent Technology Co.,Ltd. Room 202,Building 3,No.28, Dongkeng Town Yanhe West 1st Road, Dongkeng Town, Dongguan,523000, Guangdong,China
Product name:	Furniture Power Distribution Unit
Rated:	110-240VAC, 60Hz
Product model(s):	JDLO22PH, JDLO followed by 1~6, followed by 1~6, followed by T or P, followed by S or H, maybe followed by K, maybe followed by U, D or A
Product trademark:	JNDELY

This verification confirms that the product meets the requirements of the following standard.
The conformity was demonstrated based on following standard(s) listed by European Commission as harmonized with EMC Directive 2014/30/EU

EN 55032:2015+A11:2020	EN 55035:2017+A11:2020
EN IEC 61000-3-2:2019+A1:2021	EN 61000-3-3:2013/A2:2021

The verification has been carried out in accordance with individual rules and conditions agreed with the applicant. Evaluation has been carried out in accordance with:

Test report(s) No.:	MK25050138P01-E01
Test conducted by:	TMC Testing Services (Shenzhen) Co., Ltd.
Verification issue date:	May 29, 2025

Notes:

This verification refers to the above mentioned product and its conformity in regards of above mentioned standard(s) was proven on test sample.

This verification does not imply meeting all essential requirements, assessment of the series-production or any other restricted Notified Bodies conformity assessment procedure appropriate for the product.

This verification holder shall use this verification in connection to verification of conformity and technical data relevant for the product the verification was issued.

TMC Testing Services (Shenzhen) Co., Ltd.

t:86-755-86642861 cert@tmc-lab.com www.tmc-lab.com

1st Floor, Block A1, Zone A, Xinshidai Gongrong Industrial Park, No. 2, Shihuan Road, Shiyuan Street, Baoan District, Shenzhen, China



Verification of Compliance

Verification No.:	MK25050138P01-C01
Name and address of Applicant:	Dongguan Jingdeli Intelligent Technology Co.,Ltd. Room 202,Building 3,No.28, Dongkeng Town Yanhe West 1st Road, Dongkeng Town, Dongguan,523000, Guangdong,China
Name and address of Manufacturer:	Dongguan Jingdeli Intelligent Technology Co.,Ltd. Room 202,Building 3,No.28, Dongkeng Town Yanhe West 1st Road, Dongkeng Town, Dongguan,523000, Guangdong,China
Product name:	Furniture Power Distribution Unit
Product model(s):	JDLO22PH, JDLO followed by 1-6, followed by 1-6, followed by T or P, followed by S or H, maybe followed by K, maybe followed by U, D or A, JDLY followed by 1-6, followed by 1-6, followed by T or P, followed by S or H, maybe followed by K, maybe followed by U, D or A
Product trademark:	JNDELY

This verification confirms that the product meets the requirements of the following standard. The conformity was demonstrated based on following standard(s) listed by European Commission as harmonized with Directive RoHS 2.0 Directive (EU) 2015/863 and (EU)2017/2102 amending Annex II to Directive 2011/65/EU

IEC 62321-1:2013	IEC 62321-3-1:2013
IEC 62321-4:2013/AMD1:2017	IEC 62321-5:2013
IEC 62321-6:2015	IEC 62321-7-1:2015
IEC 62321-7-2:2017	IEC 62321-8:2017
IEC 62321-2:2021	

The verification has been carried out in accordance with individual rules and conditions agreed with the applicant. Evaluation has been carried out in accordance with:

Test report(s) No.:	MK25050138P01-C01
Test conducted by:	TMC Testing Services (Shenzhen) Co., Ltd.
Verification issue date:	May 29, 2025

Notes:

This verification refers to the above mentioned product and its conformity in regards of above mentioned standard(s) was proven on test sample.

This verification does not imply meeting all essential requirements, assessment of the series-production or any other restricted Notified Bodies conformity assessment procedure appropriate for the product.

This verification holder shall use this verification in connection to verification of conformity and technical data relevant for the product the verification was issued.

TMC Testing Services (Shenzhen) Co., Ltd.

t:86-755-86642861 cert@tmc-lab.com www.tmc-lab.com

1st Floor, Block A1, Zone A, Xinshidai Gongrong Industrial Park, No. 2, Shihuan Road, Shiyuan Street, Baoan District, Shenzhen, China



Verification of Compliance

Verification No.:	MK25050138P01-S01
Name and address of Applicant:	Dongguan Jingdeli Intelligent Technology Co.,Ltd. Room 202, Building 3, No.28, Dongkeng Town Yanhe West 1st Road, Dongkeng Town, Dongguan, 523000, Guangdong, China
Name and address of Manufacturer:	Dongguan Jingdeli Intelligent Technology Co.,Ltd. Room 202, Building 3, No.28, Dongkeng Town Yanhe West 1st Road, Dongkeng Town, Dongguan, 523000, Guangdong, China
Product name:	Furniture Power Distribution Unit
Rated:	Input: 100-240VAC, 50/60Hz, Max.16A; 2*USB Output: DC 5V, 2A JDLO22PH,
Product model(s):	JDLO followed by 1-6, followed by 1-6, followed by T or P, followed by S or H, maybe followed by K, maybe followed by U, D or A
Product trademark:	JNDELY

This Verification confirms that the product meets the requirements of the following standard.
The conformity was demonstrated based on following standard(s) listed by European Commission as harmonized with LVD Directive 2014/35/EU.

EN IEC 62368-1:2024+A11:2024
IEC 60884-1:2002+A1:2006+A2:2013

The Verification has been carried out in accordance with individual rules and conditions agreed with the applicant. Evaluation has been carried out in accordance with:

Test report(s) No.:	MK25050138P01-S01
Test conducted by:	TMC Testing Services (Shenzhen) Co., Ltd.
Verification issue date:	May 30, 2025

Notes:

This Verification refers to the above mentioned product and its conformity in regards of above mentioned standard(s) was proven on test sample.

This Verification does not imply meeting all essential requirements, assessment of the series-production or any other restricted Notified Bodies conformity assessment procedure appropriate for the product.

This Verification holder shall use this Verification in connection to Verification of conformity and technical data relevant for the product the Verification was issued.

TMC Testing Services (Shenzhen) Co., Ltd.

t:86-755-86642861 cert@tmc-lab.com www.tmc-lab.com

1/F. of Building A1, 5/F. of Building B1, & 1/F. of Building A3, Xinshidai Gongrong Industrial Park, No.2, Shihuan Road, Shilong Community, Shiyan Subdistrict, Bao'an District, Shenzhen, Guangdong, China



Dodd Tang
Lab Director
Dodd Tang



Shenzhen ZKT Technology Co., Ltd.
 1/F, No. 101, Building B, No. 6, Tangwei Community Industrial Avenue,
 Fuhai Street, Bao'an District, Shenzhen, China



Certificate of Compliance

Certificate Number: ZKT-250902L21450C

Certificate's Holder : Shenzhen Lanling Optoelectronics Technology Co., Ltd
 511-G5, Building C, No. 101 Fukang Road, Henggang Community,
 Henggang Street, Longgang District, Shenzhen City, Guangdong
 Province

Manufacturer : Shenzhen Lanling Optoelectronics Technology Co., Ltd
 511-G5, Building C, No. 101 Fukang Road, Henggang Community,
 Henggang Street, Longgang District, Shenzhen City, Guangdong
 Province

Trade Mark : /

Product : LED Strip

Model(s) : CWG-5050RGB-60D-5v
 LED5050X18, LED5050X30, LED5050X48, LED5050X60, LED5050X72,
 LED5050X90, LED5050X120, LED2835X30, LED2835X60,
 LED2835X120, LED2835X180, LED2835X240, LED3528X30,
 LED3528X60, LED3528X120, LED3528X240, LED5730X60,
 LED5730X72, LED5730X84, LED3535X60, LED3535X120

Test Standard : EN IEC 62031:2020+A11:2021

This Attestation of Compliance is issued on a voluntary basis for electrical equipment below the voltage limits of Low Voltage Directive 2014/35/EU. The essential requirements are fulfilled accordingly based on the technical specifications applicable at the time of issuance. See also notes overleaf. It is only valid in connection with the test report number: ZKT-250902L21450S.

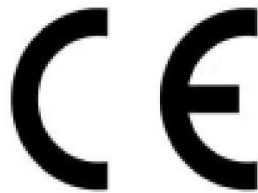

This Certificate of Conformity is based on single evaluation of the submitted sample(s) of the above mentioned product. It does not imply an assessment of the whole product and relevant Directives to be observed.

Shenzhen ZKT Technology Co., Ltd.
 1/F, No. 101, Building B, No. 6, Tangwei Community Industrial Avenue,
 Fuhai Street, Bao'an District, Shenzhen, China



Certificate of Compliance

Certificate Number: ZKT-250902L21449C

Certificate's Holder : Shenzhen Lanling Optoelectronics Technology Co., Ltd
 511-G5, Building C, No. 101 Fukang Road, Henggang Community,
 Henggang Street, Longgang District, Shenzhen City, Guangdong
 Province

Manufacturer : Shenzhen Lanling Optoelectronics Technology Co., Ltd
 511-G5, Building C, No. 101 Fukang Road, Henggang Community,
 Henggang Street, Longgang District, Shenzhen City, Guangdong
 Province

Trade Mark : /

Product : LED Strip

Model(s) : CWG-5050RGB-60D-5V
 LED5050X18, LED5050X30, LED5050X48, LED5050X72, LED5050X90,
 LED5050X120, LED2835X30, LED2835X60, LED2835X120,
 LED2835X180, LED2835X240, LED3528X30, LED3528X60,
 LED3528X120, LED3528X240, LED5730X60, LED5730X72, LED5730X84,
 LED3535X60, LED3535X120

Test Standard : EN IEC 55015:2019+A11:2020
 EN IEC 61000-3-2:2019 + A1:2021 + A2:2024
 EN 61000-3-3:2013 + A1:2019 + A2:2021
 EN IEC 61547:2023

This Attestation of Compliance is issued on a voluntary basis for electrical equipment below the voltage limits of EMC Directive 2014/30/EU. The essential requirements are fulfilled accordingly based on the technical specifications applicable at the time of issuance. See also notes overleaf. It is only valid in connection with the test report number: ZKT-250902L21449E.



This Certificate of Conformity is based on single evaluation of the submitted sample(s) of the above mentioned product. It does not imply an assessment of the whole product and relevant . Directives to be observed.

Shenzhen ZKT Technology Co., Ltd.
 1/F, No. 101, Building B, No. 6, Tangwei Community Industrial Avenue,
 Fuhai Street, Bao'an District, Shenzhen, China



Certificate of Compliance

Certificate Number: ZKT-260114L0992C

Certificate's Holder : Shenzhen Lanling Optoelectronics Technology Co., Ltd
Address : 511-G5, Building C, No. 101 Fukang Road, Henggang Community, Henggang Street, Longgang District, Shenzhen City, Guangdong Province
Manufacturer : Shenzhen Lanling Optoelectronics Technology Co., Ltd
Address : 511-G5, Building C, No. 101 Fukang Road, Henggang Community, Henggang Street, Longgang District, Shenzhen City, Guangdong Province
Product : Controller strip lights
Trade Mark : /
Model(s) : YH-358
 LL-LED5050X60, LL-LED5050X18, LL-LED5050X30,
 LL-LED5050X48, LL-LED5050X60, LL-LED5050X72,
 LL-LED5050X90, LL-LED5050X120, LL-LED2835X30,
 LL-LED2835X60, LL-LED2835X120, LL-LED2835X180,
 LL-LED2835X240, LL-LED3528X30, LL-LED3528X60,
 LL-LED3528X120, LL-LED3528X240, LL-LED5730X60,
 LL-LED5730X72, LL-LED5730X84, LL-LED3535X60,
 LL-LED3535X120, CWG-5050RGB-60D-5v
Test Method : IEC 62321-5:2013 & IEC 62321-4:2013+A1:2017 &
 IEC 62321-7-2:2017 & IEC 62321-6:2015 & IEC 62321-8:2017
 & IEC 62321-3-1:2013 & IEC 62321-7-1:2015

The following products have been tested by us and found in conformity with the (RoHS) Directive 2011/65/EU Annex II amending Annex (EU)2015/863 and amending Annex (EU)2017/2102. It is possible to use CE Marking to demonstrate the conformity with this Directive. It is only valid in connection with the test report number: ZKT-260114L0992R. After preparation of the necessary technical documentation according the requirement of EN IEC 63000:2018 as well as the verification of conformity the CE marking as shown below can be affixed on the equipment.

RoHS



This Certificate of Conformity is based on single evaluation of the submitted sample(s) of the above mentioned product. It does not imply an assessment of the whole product and relevant Directives to be observed.

Shenzhen ZKT Technology Co., Ltd.

1/F, No. 101, Building B, No. 6, Tangwei Community Industrial Avenue,
Fuhai Street, Bao'an District, Shenzhen, China



Certificate of Compliance

Certificate Number: ZKT-260105L0127C

Certificate's Holder : Shenzhen Lanling Optoelectronics Technology Co., Ltd
511-G5, Building C, No. 101 Fukang Road, Henggang Community, Henggang Street, Longgang District, Shenzhen City, Guangdong Province

Manufacturer : Shenzhen Lanling Optoelectronics Technology Co., Ltd
511-G5, Building C, No. 101 Fukang Road, Henggang Community, Henggang Street, Longgang District, Shenzhen City, Guangdong Province

Trade Mark : /

Product : Controller strip lights

Model(s) : YH-358

REQUIREMENT	STANDARD	Report No.
Art.3.1(a) Safety	EN 60598-2-21:2015 EN IEC 60598-1:2024+A11:2024 EN IEC 62031:2020+A11:2021	ZKT-260105L0128S
Art.3.1(a) Health	EN 62479:2010 EN 50663:2017	ZKT-260105L0127E-3
Art.3.1(b) EMC	ETSI EN 301 489-1 V2.2.3 (2019-11) ETSI EN 301 489-17 V3.3.1 (2024-09) EN IEC 61000-3-2:2019 + A1:2021 + A2:2024 EN 61000-3-3:2013 + A1:2019 + A2:2021	ZKT-260105L0127E-1
Art.3.2 Radio	ETSI EN 300 328 V2.2.2 (2019-07)	ZKT-260105L0127E-2

This Attestation of Compliance is issued on for electrical equipment below the voltage limits of Radio Equipment Directive (RED) 2014/53/EU. The essential requirement are fulfilled accordingly based on the technical specifications applicable at the time of issuance.

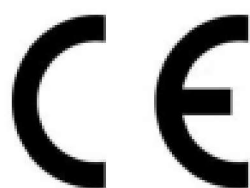

This Certificate of Conformity is based on single evaluation of the submitted sample(s) of the above mentioned product. It does not imply an assessment of the whole product and relevant . Directives to be observed.