

Installation sanleitung Installation Instruction Instruction d'installation

SKU:N634P413107N / N634P413108N

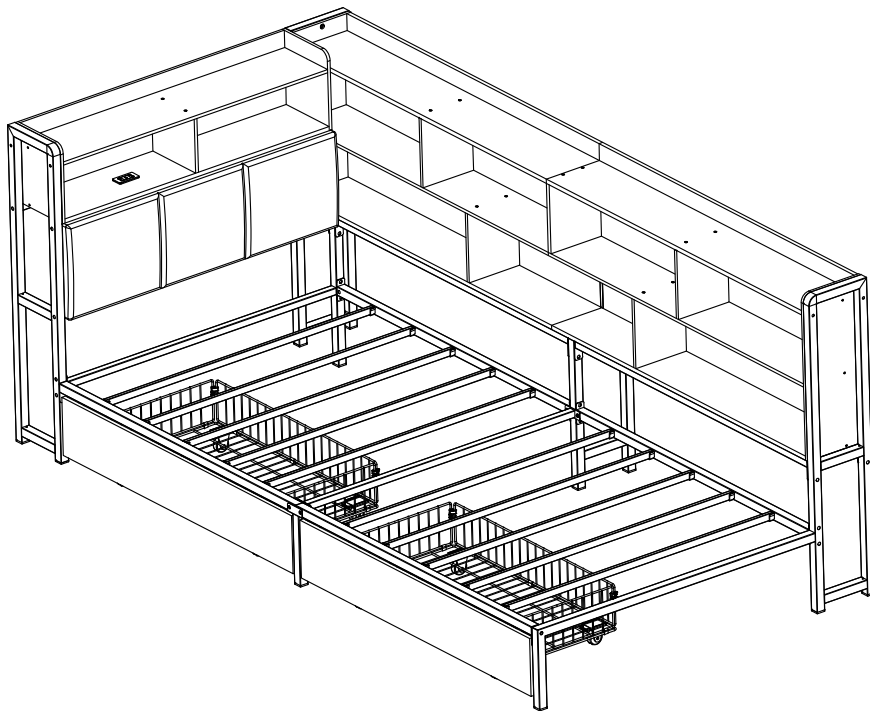

DE:Unser Produkt wird Ihnen in 2 Paketen geliefert. Die Lieferzeiten dieser 2 Pakete können abweichen, bitte haben Sie etwas Geduld und vielen Dank für Ihr Verständnis.

UK:Our product will be delivered to you in 2 packages. The delivery times of these 2 packages may differ, please be patient and thank you for your understanding.

FR:Notre produit vous sera livré en 2 colis. Les délais de livraison de ces 2 colis peuvent différer, soyez patient et merci pour votre compréhension.



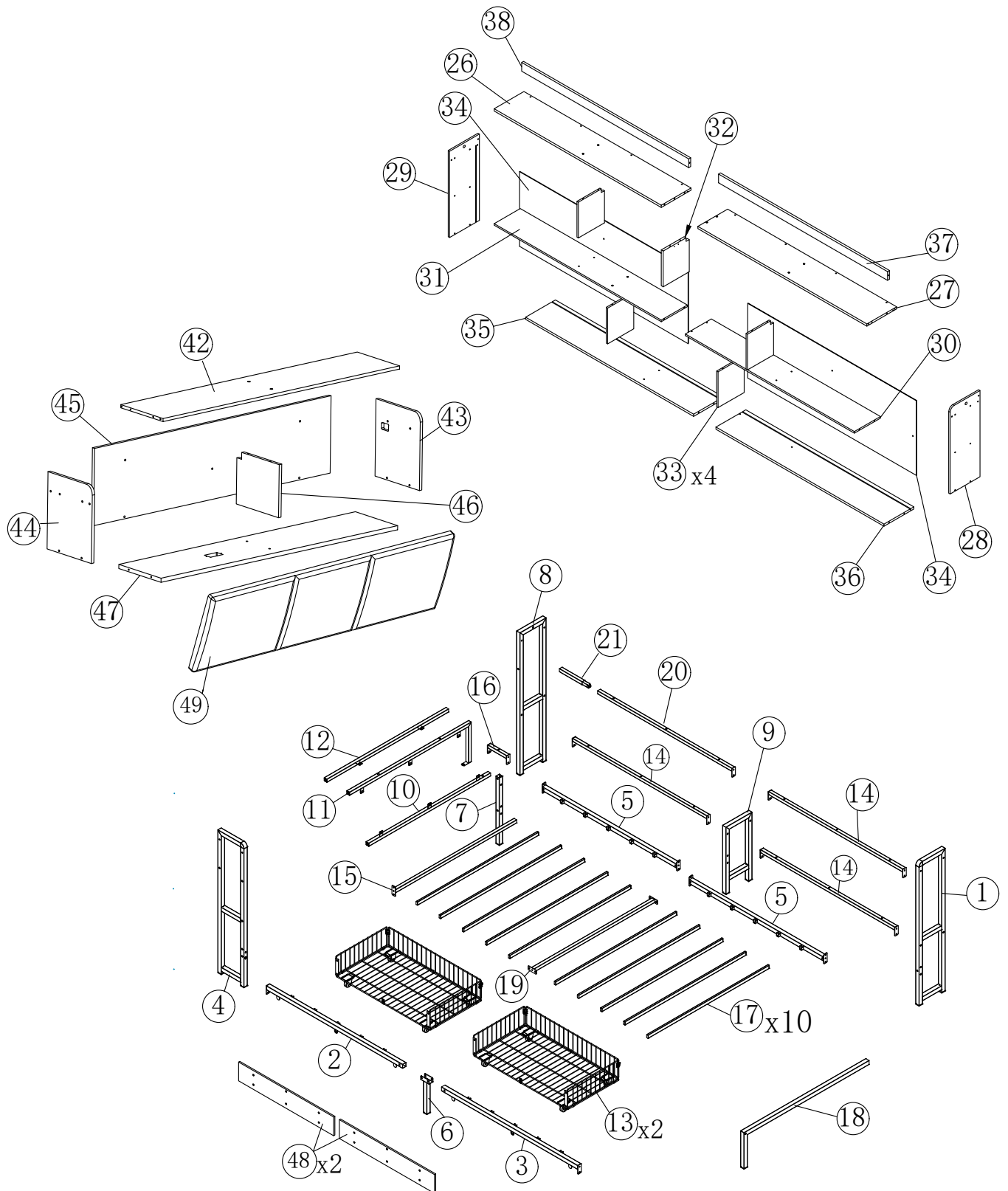





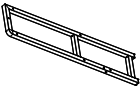
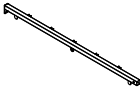

Stückliste

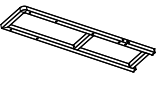
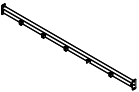

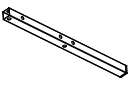
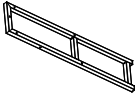
Part List

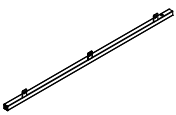
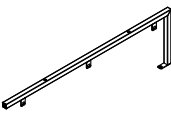
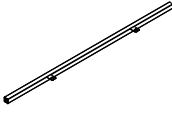
(Liste der Einzelteile)

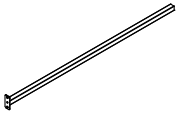

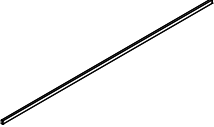
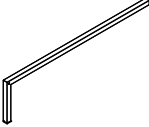
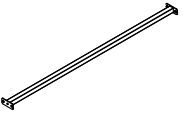
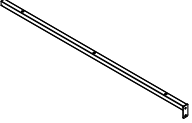
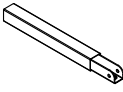

N634P413107N

① x1 	② x1 	③ x1 
Outer side frame leg (Äußeres Seitenrahmenbein)	Headboard side tube - left (Kopfteil-Seitenrohr - links)	Footboard side tube - left (Fußteil-Seitenrohr - links)
④ x1 	⑤ x2 	⑥ x1 
Headboard outer leg (Äußeres Kopfteilbein)	Side support bar (Seitliche Zugstange)	Bed side leg (Bettseitenbein)
⑦ x1 	⑧ x1 	⑨ x1 
Headboard post (Kopfteilpfosten)	Inner side frame leg (Inneres Seitenrahmenbein)	Bed side frame (Bettseitenrahmen)
⑩ x1 	⑪ x1 	⑫ x1 
Headboard backrest tube 1 (Kopfteil-Lehnenrohr 1)	Headboard backrest tube 2 (Kopfteil-Lehnenrohr 2)	Headboard backrest tube 3 (Kopfteil-Lehnenrohr 3)
⑬ x2 	⑭ x3 	⑮ x1 
Wire drawer (Drahtkorb-Schublade)	Inner side cross tube - left (Innere Seitenquerstange - links)	Headboard support bar (Kopfteil-Zugstange)
⑯ x1 	⑰ x10 	⑱ x1 
Upper side support tube (Obere Seitenstützstange)	Bed slat (Bettlatte)	Footboard leg (Fußteilbein)
⑲ x1 	⑳ x1 	㉑ x1 
Center support bar (Mittlere Stützstange)	Outer side cross tube (Äußere Seitenquerstange)	Outer side cross tube (extension) (Äußere Seitenquerstange (Verlängerung))

Part List

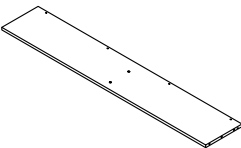
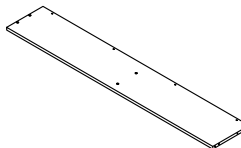

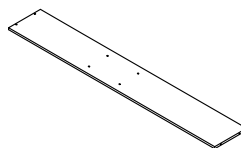
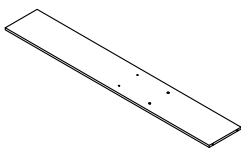

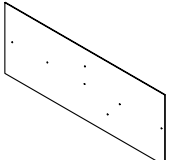
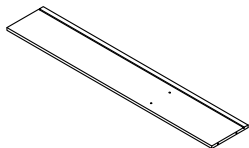
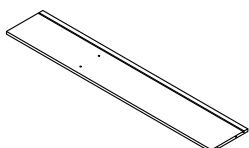
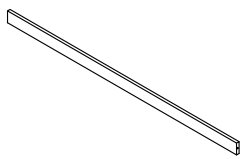
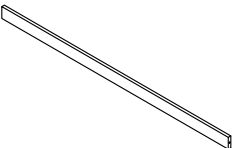
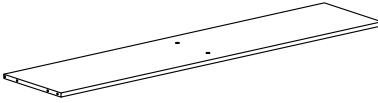
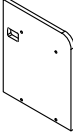
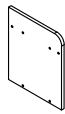
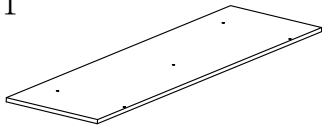
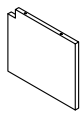
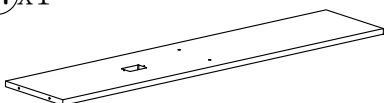
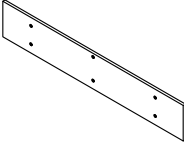
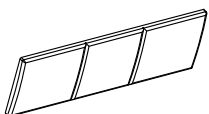





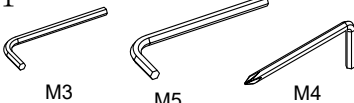







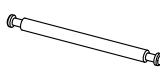



(Liste der Einzelteile)

N634P413108N

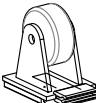
<p>②⑥ x1</p> 	<p>②⑦ x1</p> 	<p>②⑧ x1</p> 
<p>Bed side top panel - L (Bettseiten-Deckplatte - L)</p>	<p>Bed side top panel - R (Bettseiten-Deckplatte - R)</p>	<p>Bed side panel - R (Bettseitenplatte - R)</p>
<p>②⑨ x1</p> 	<p>③⑩ x1</p> 	<p>③① x1</p> 
<p>Bed side panel - L (Bettseitenplatte - L)</p>	<p>Bed side shelf-R Bettseiten-Regalboden-R</p>	<p>Bed side shelf-L (Bettseiten-Regalboden-L)</p>
<p>③② x1</p> 	<p>③③ x4</p> 	<p>③④ x2</p> 
<p>Bed side divider panel (Bettseiten-Trennplatte)</p>	<p>Bed side divider panel 1 (Bettseiten-Trennplatte 1)</p>	<p>Bed side back panel (Bettseiten-Rückwand)</p>
<p>③⑤x1</p> 	<p>③⑥x1</p> 	<p>③⑦x1</p> 
<p>Bed side bottom panel - L (Bettseiten-Bodenplatte - L)</p>	<p>Bed side bottom panel - R (Bettseiten-Bodenplatte - R)</p>	<p>Bed side board-L (Nachttisch-L)</p>
<p>③⑧x1</p> 	<p>④②x1</p> 	<p>④③x1</p> 
<p>Bed side board-R (Nachttisch-R)</p>	<p>Headboard shelf (Kopfteil-Regalboden)</p>	<p>right side panel (rechte Seitenwand)</p>
<p>④④x1</p> 	<p>④⑤x1</p> 	<p>④⑥x1</p> 
<p>Headboard left panel (Kopfteil linke Seitenplatte)</p>	<p>Headboard back panel (Kopfteil-Rückwand)</p>	<p>Headboard divider (Kopfteil-Trennplatte)</p>
<p>④⑦x1</p> 	<p>④⑧x2</p> 	<p>④⑨x1</p> 
<p>Headboard baseboard (Kopfteil Fußleiste)</p>	<p>Drawer wooden panel (Schubladen-Holzplatte)</p>	<p>Upholstered backrest (Gepolsterte Rückenlehne)</p>

Hardware list (Hardwareliste)

N634P413107N

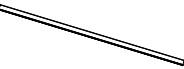
<p>Ax1</p>  <p>M3 M5 M4</p>	<p>Bx8</p>  <p>M8x10mm</p>	<p>Cx14</p>  <p>M6x10mm</p>
<p>wrench (Schlüssel)</p>	<p>Screw (Schraube)</p>	<p>Screw (Schraube)</p>
<p>Dx29</p>  <p>M8x35mm</p>	<p>Ex2</p>  <p>M6*10(Ø8*5)</p>	<p>Fx12</p>  <p>M8</p>
<p>Screw (Schraube)</p>	<p>Positioningscrew (Positionsschraube)</p>	<p>Anti-slipnut (Sicherungsmutter)</p>
<p>Gx59</p>  <p>M5x28mm</p>	<p>Hx6</p>  <p>M5x50mm</p>	<p>Ix5</p>  <p>Ø5*70</p>
<p>Connecting bolt (Verbindungsbolzen)</p>	<p>Connecting bolt (Verbindungsbolzen)</p>	<p>Double-endedcamconnector (DoppelseitigerVerbinder)</p>
<p>Jx10</p> 	<p>Kx3</p>  <p>Ø6*30</p>	<p>Lx2</p>  <p>M3x10mm</p>
<p>Cam lock (Exzenter)</p>	<p>Wooden dowel (Holzdübel)</p>	<p>Self-tapping screw (Selbstschneidende Schraube)</p>
<p>Mx1</p> 	<p>Nx17</p>  <p>M6x28mm</p>	<p>Ox26</p>  <p>M4x10mm</p>
<p>socket (Steckdose)</p>	<p>Screw (Schraube)</p>	<p>Large flat-head self-tapping screw (Große Flachkopf-Blechschaube)</p>
<p>Px2</p> 	<p>Qx4</p> 	<p>Rx8</p> 
<p>hinge (Scharnier)</p>	<p>Wire clip (Drahtklammer)</p>	<p>small wheel (kleines Rad)</p>
<p>Sx1</p> 	<p>Tx2</p> 	<p>Ux14</p> 
<p>Corner bracket (Eckwinkel)</p>	<p>Connecting iron plate (Verbindungsblech)</p>	<p>decorative sticker (Dekorativer Aufkleber)</p>
<p>Vx1</p>  <p>V1x1</p>  <p>V2x12</p>  <p>LED strip clip (LED-Befestigungsclip)</p>	<p>X x1</p>  <p>H-shaped clip strip (H-Klemmschiene)</p>	

DE:Vor dem Einbau die Schrauben in die Löcher stecken und festziehen, aber nicht bis 100%, 70% bis 80% anziehen reicht aus. Schließlich, nachdem alle Schrauben installiert sind, ziehen Sie alle Schrauben auf 100%.

Wenn Sie auf diese Probleme stoßen, wie z. B. Fehlausrichtung der Löcher oder Unfähigkeit, bestimmte Teile zu installieren, überprüfen Sie bitte, ob die Schrauben korrekt verwendet werden und passen Sie die Dichtigkeit der Schrauben an.

UK:Before installation, insert the screws into the holes and tighten them, but do not tighten them to 100%, 70% to 80% is sufficient. Finally, after all screws are installed, tighten all screws to 100%.

If you encounter these issues, such as if the holes cannot be aligned or some parts cannot be installed, please check if the screws are used correctly and adjust the tightness of the screws.

FR:Insérer la vis dans le trou avant la fin de l'assemblage, serrer la vis, mais ne pas serrer à 100%, 70% ~ 80% est correct. Enfin, une fois que toutes les vis sont bien serrées, toutes les vis sont serrées à 100%.



Si vous rencontrez ces problèmes, par exemple si les trous ne sont pas alignés ou si certaines pièces ne peuvent pas être montées, vérifiez que les vis sont utilisées correctement et Ajustez leur serrage.

Attention: Do not tighten the screws before completing the entire installation. If you have any difficulty with the installation process, please feel free to contact us.

(Achtung: Ziehen Sie die Schrauben erst fest, wenn die gesamte Installation abgeschlossen ist. Wenn Sie beim Installationsvorgang Schwierigkeiten haben, können Sie sich gerne an uns wenden.)

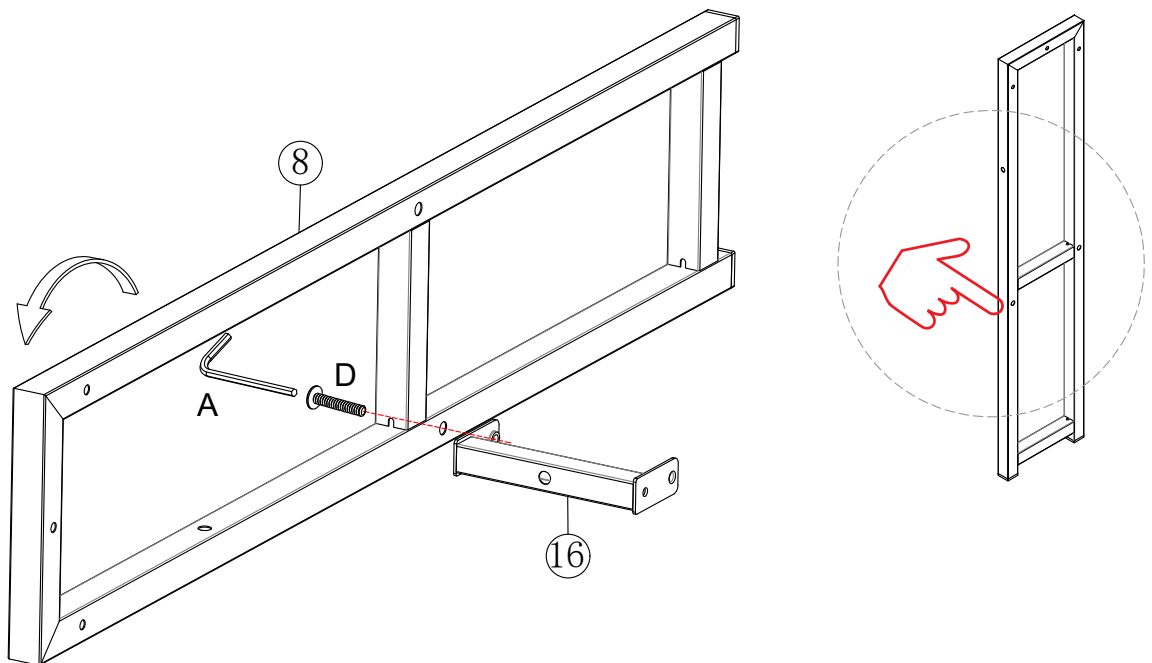

Step 1:



A Allen Key	D Bolts x 1
 M5	 M8x35mm

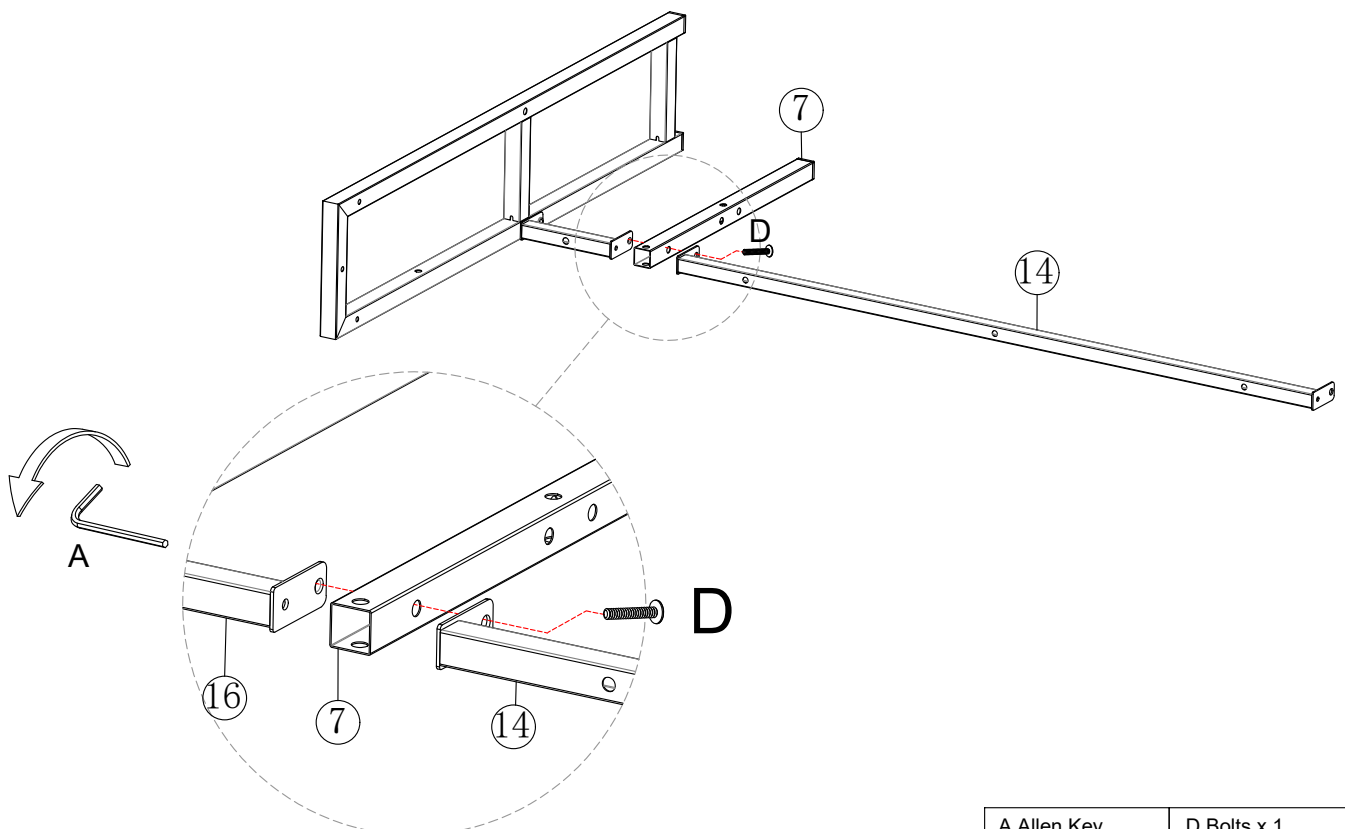

Step 2:



A Allen Key	D Bolts x 1
 M5	 M8x35mm

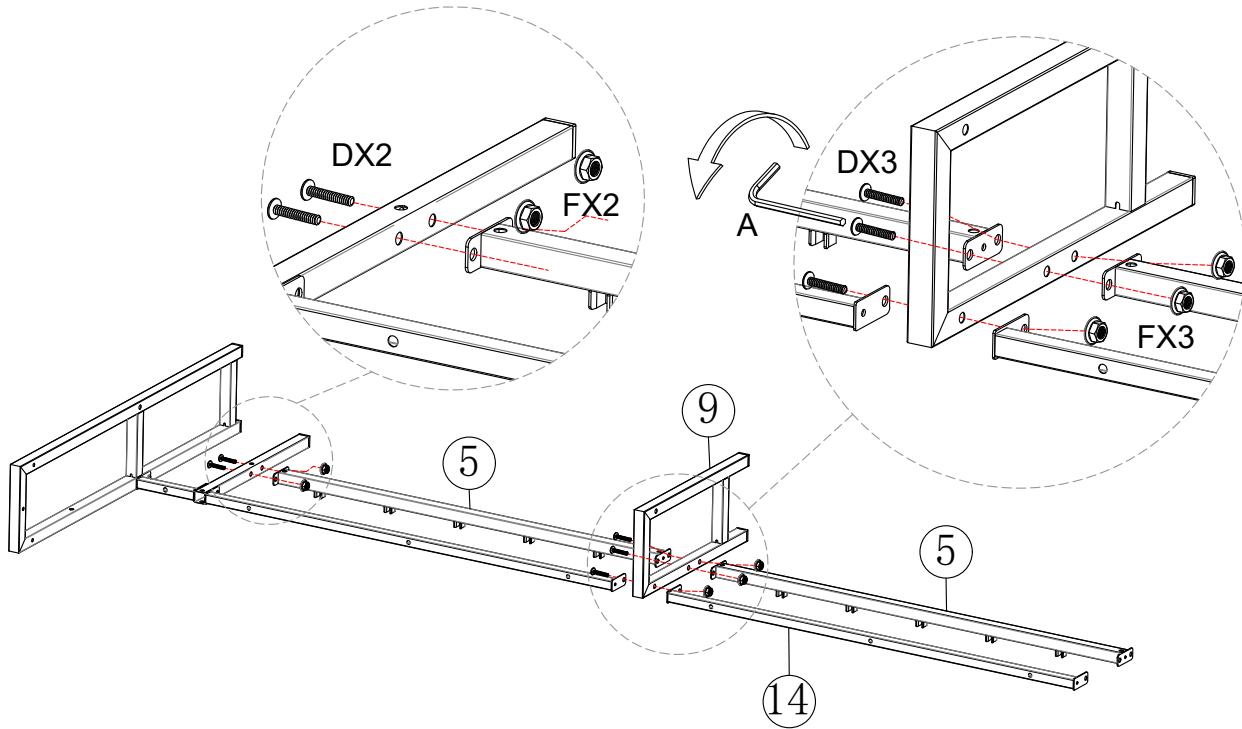

Step 3:

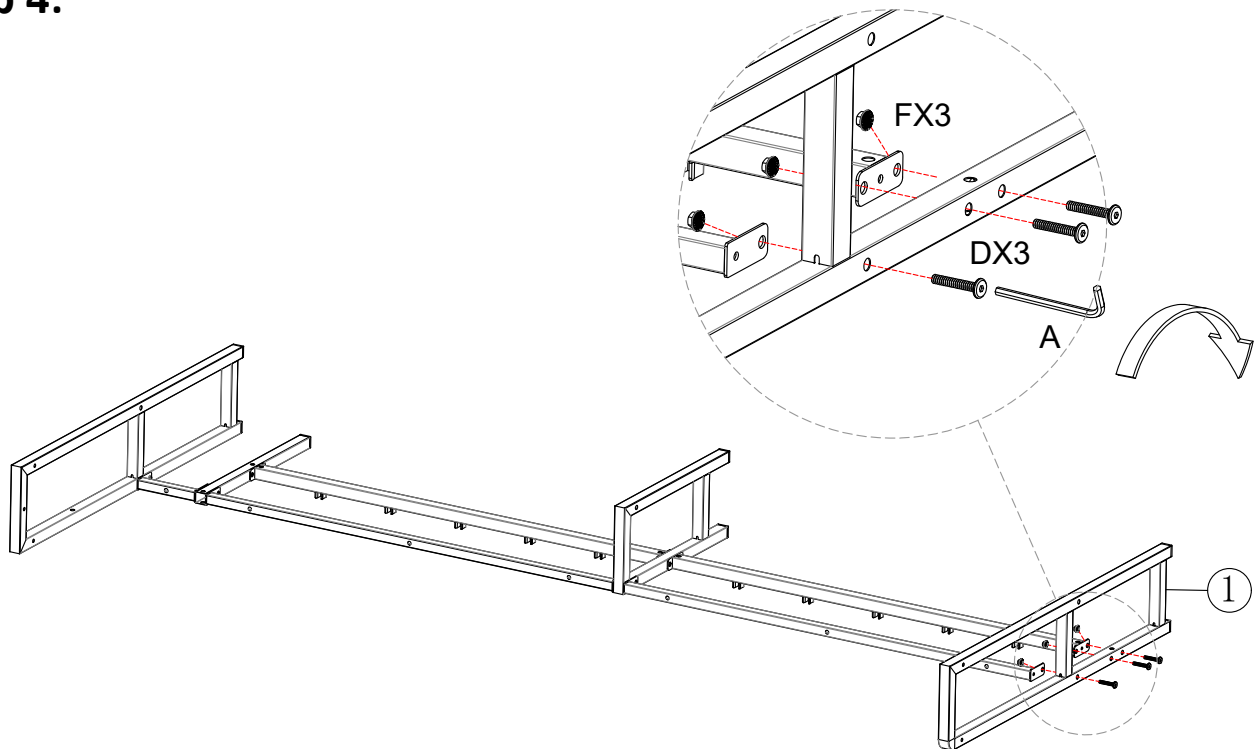

A Allen Key  M5	D Bolts x5  M8x35mm	F Anti-slip nut x5  M8
--	--	---

Step 4:



A Allen Key  M5	D Bolts x3  M8x35mm	F Anti-slip nut x3  M8
--	--	---

Step 5:

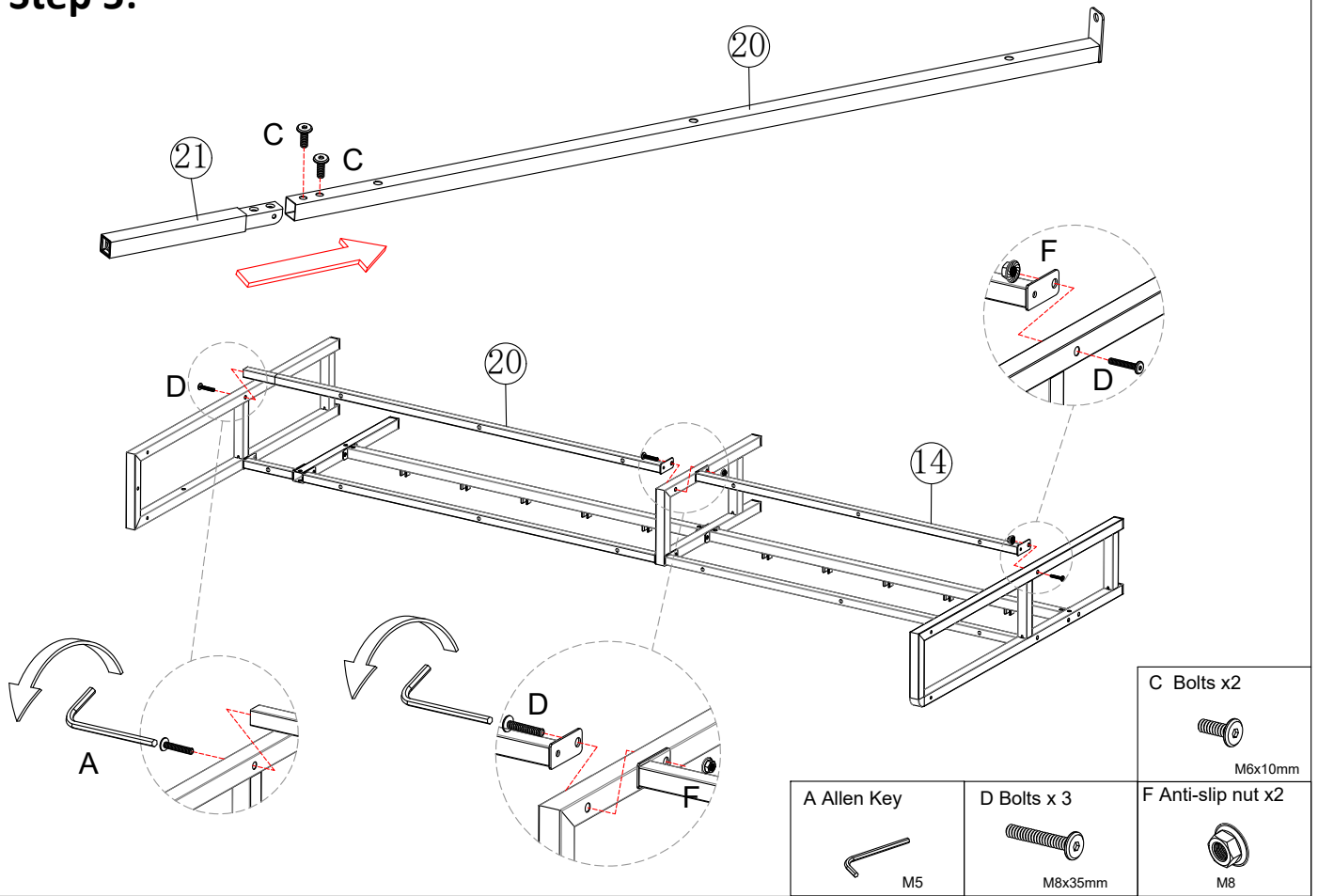

Step 6:

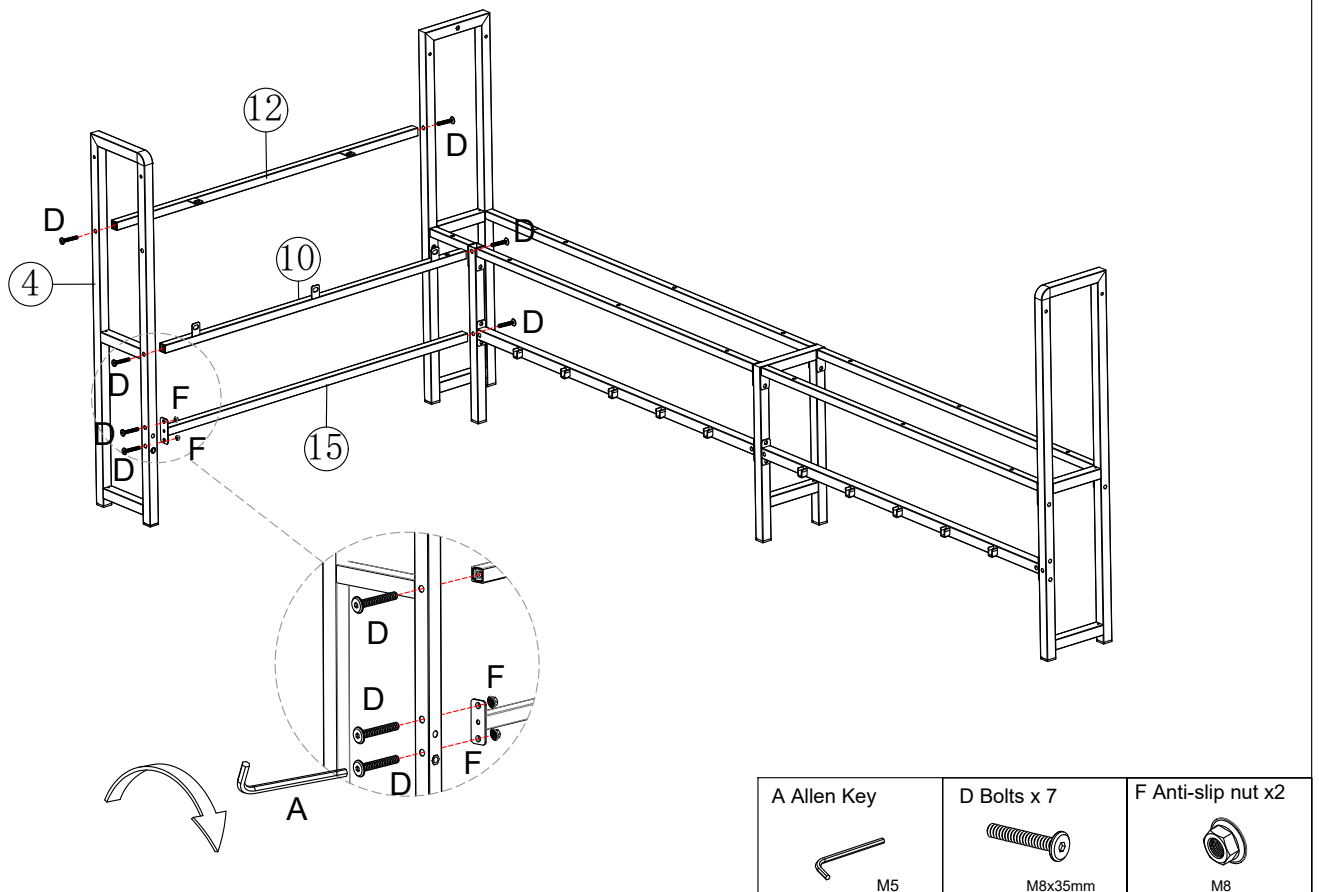

Step 7:

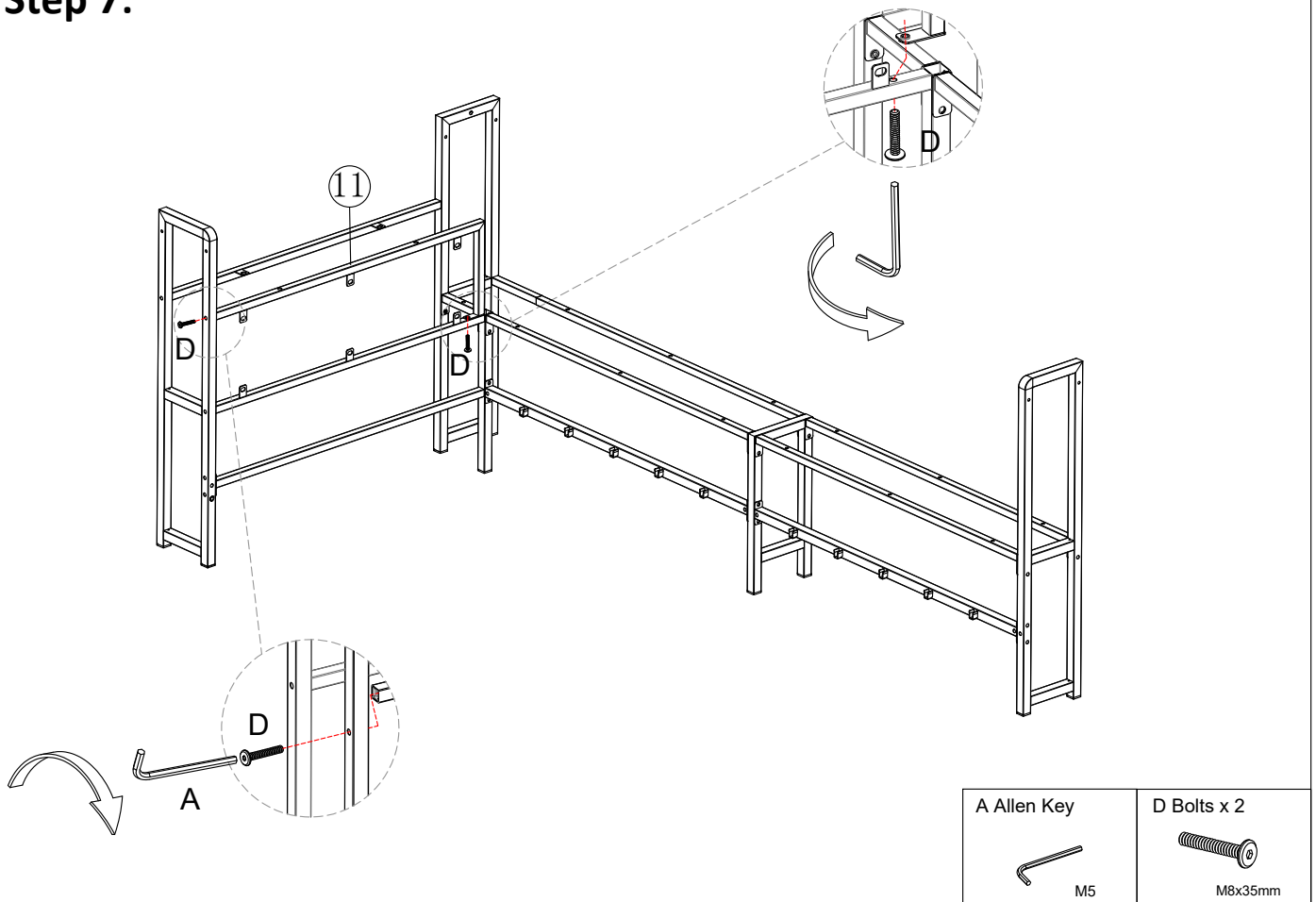

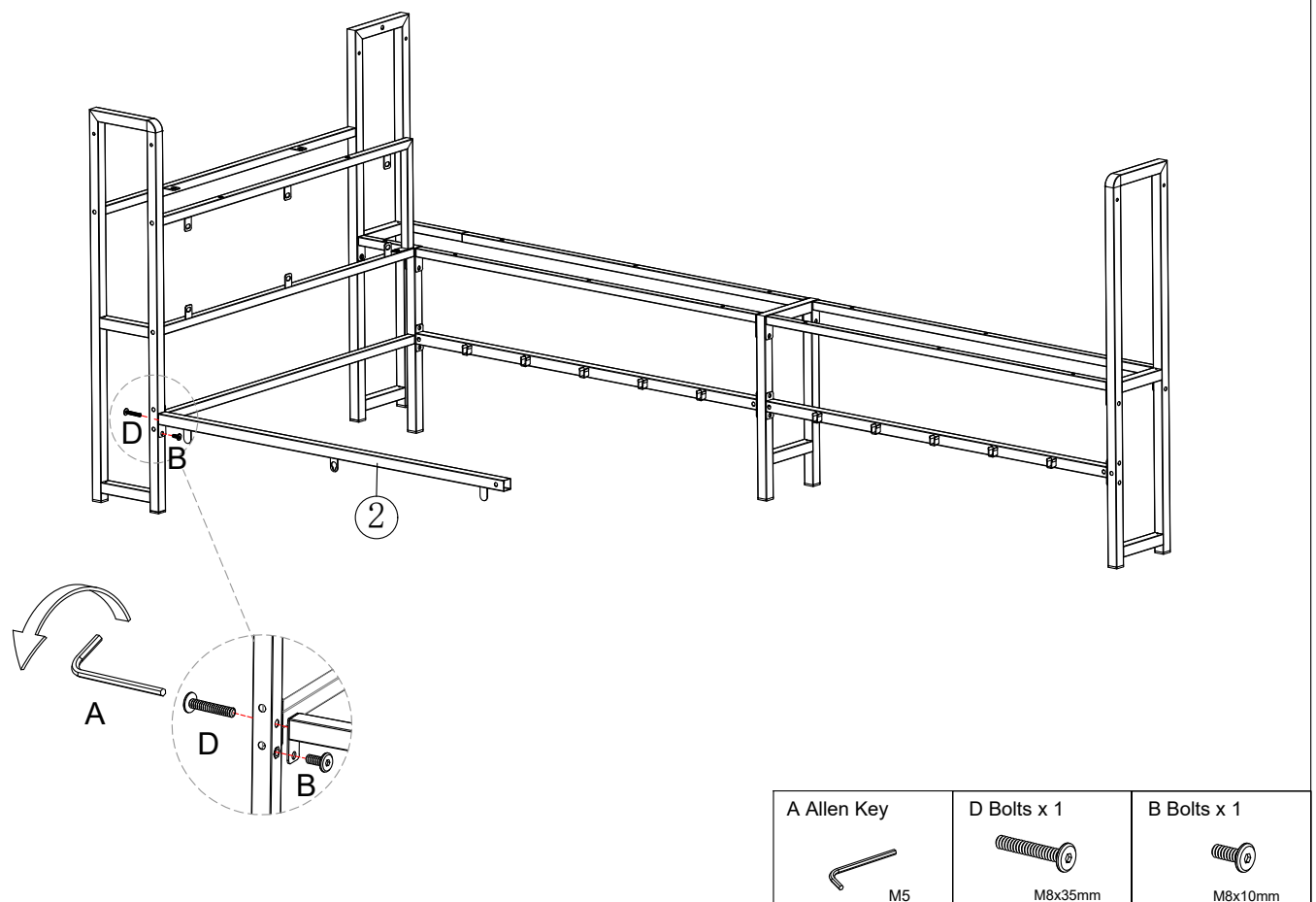

Step 8:



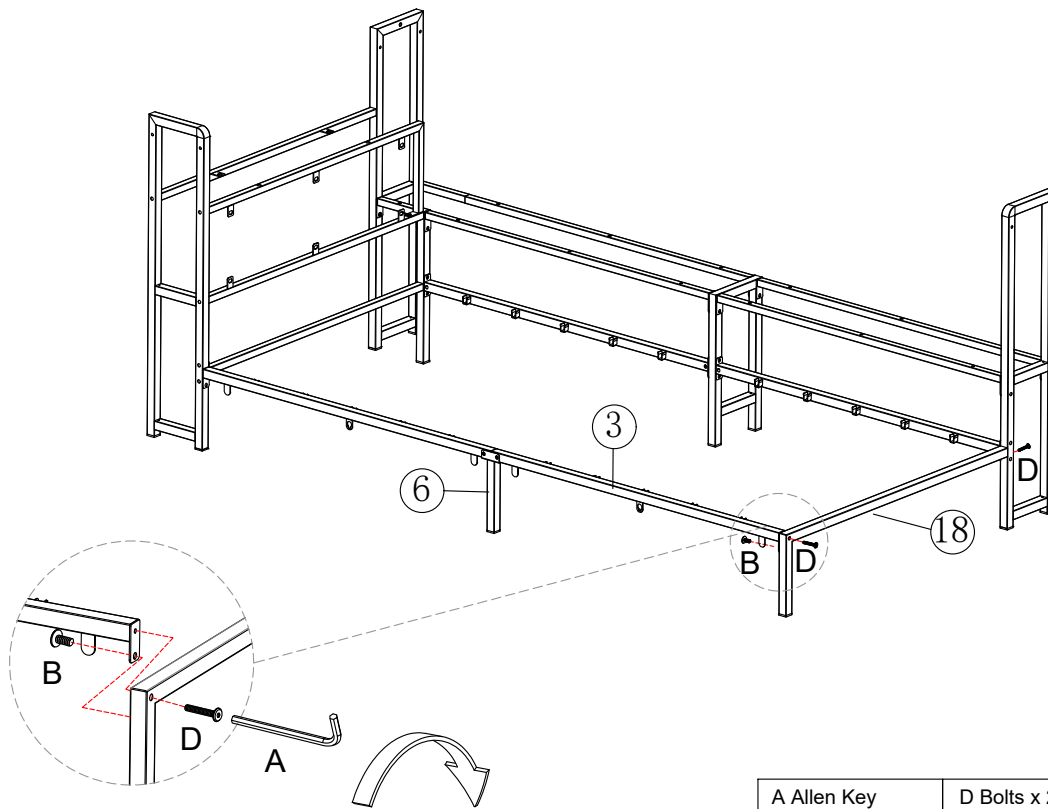

Step 9:



<p>A Allen Key</p>  <p>M5</p>	<p>D Bolts x 2</p>  <p>M8x35mm</p>	<p>B Bolts x 1</p>  <p>M8x10mm</p>
--	---	---

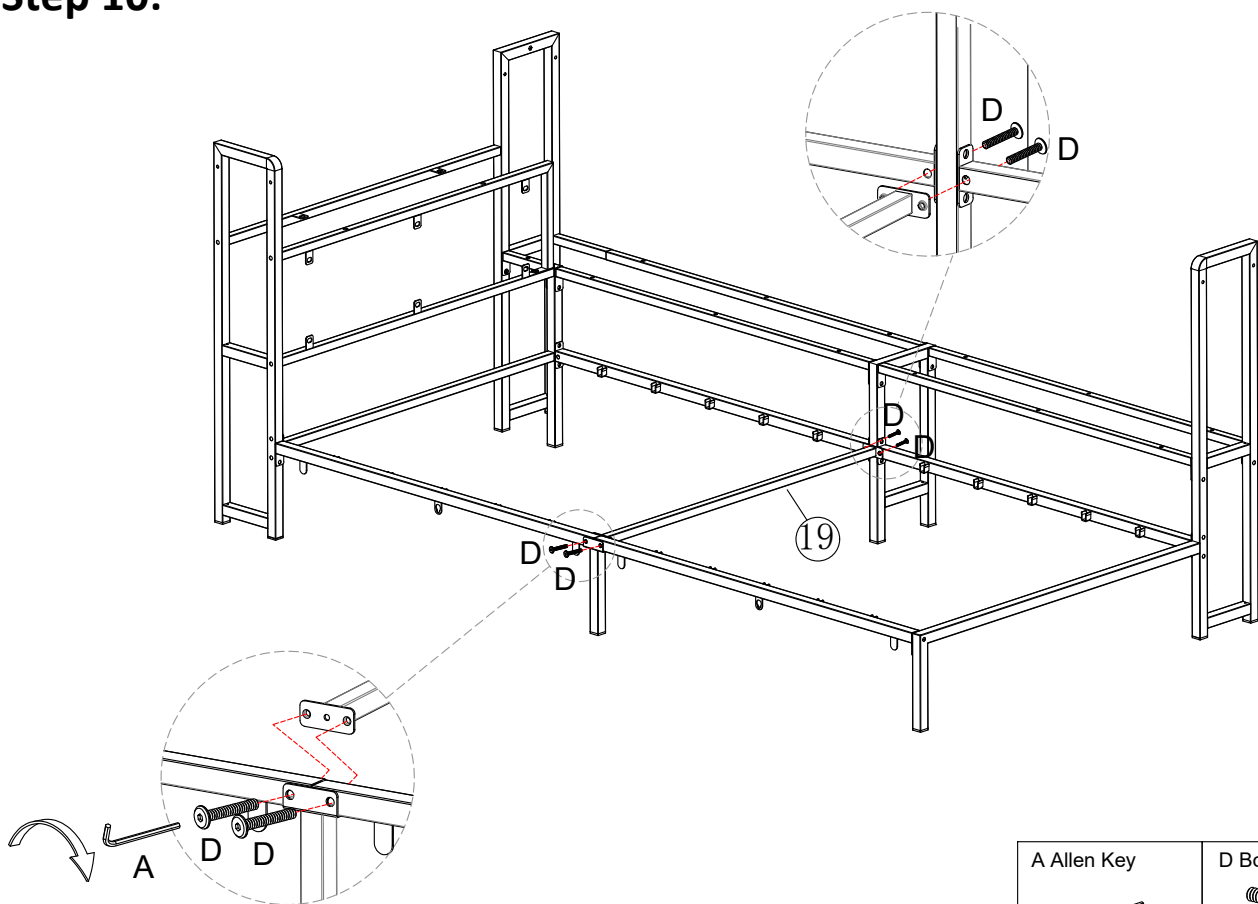

Step 10:

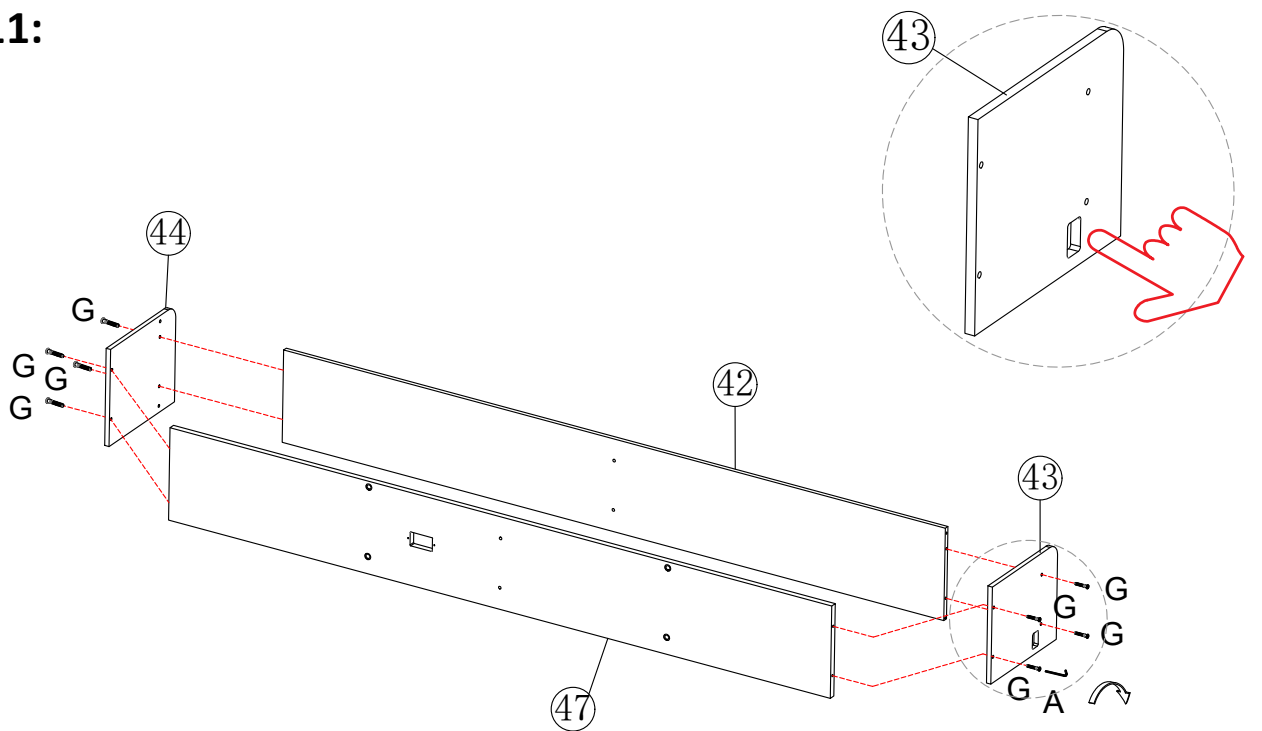

<p>A Allen Key</p>  <p>M5</p>	<p>D Bolts x 4</p>  <p>M8x35mm</p>
--	---

Step 11:



<p>A Allen Key</p>  <p>M3</p>	<p>G Connecting bolt x 8</p>  <p>M5x28mm</p>
--	---

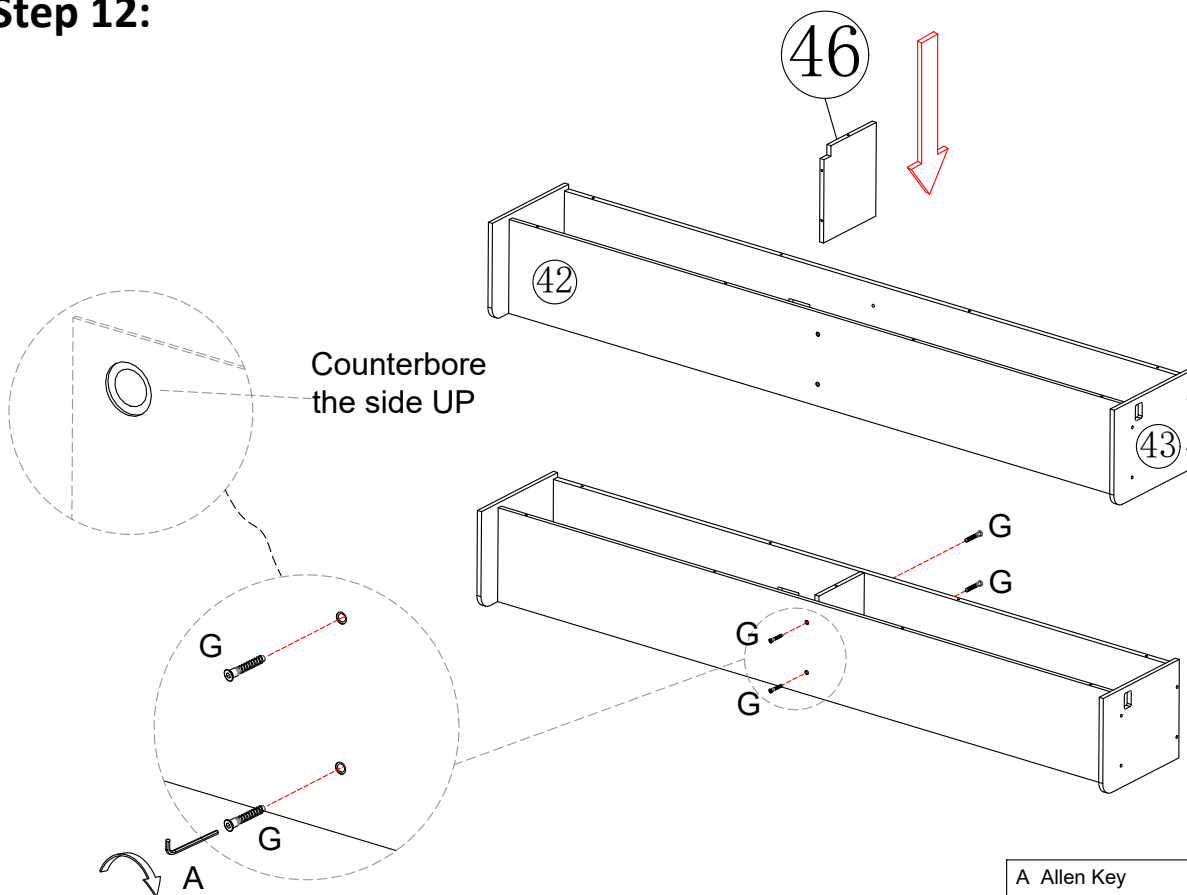

Step 12:



<p>A Allen Key</p>  <p>M3</p>	<p>G Connecting bolt x 4</p>  <p>M5x28mm</p>
--	---

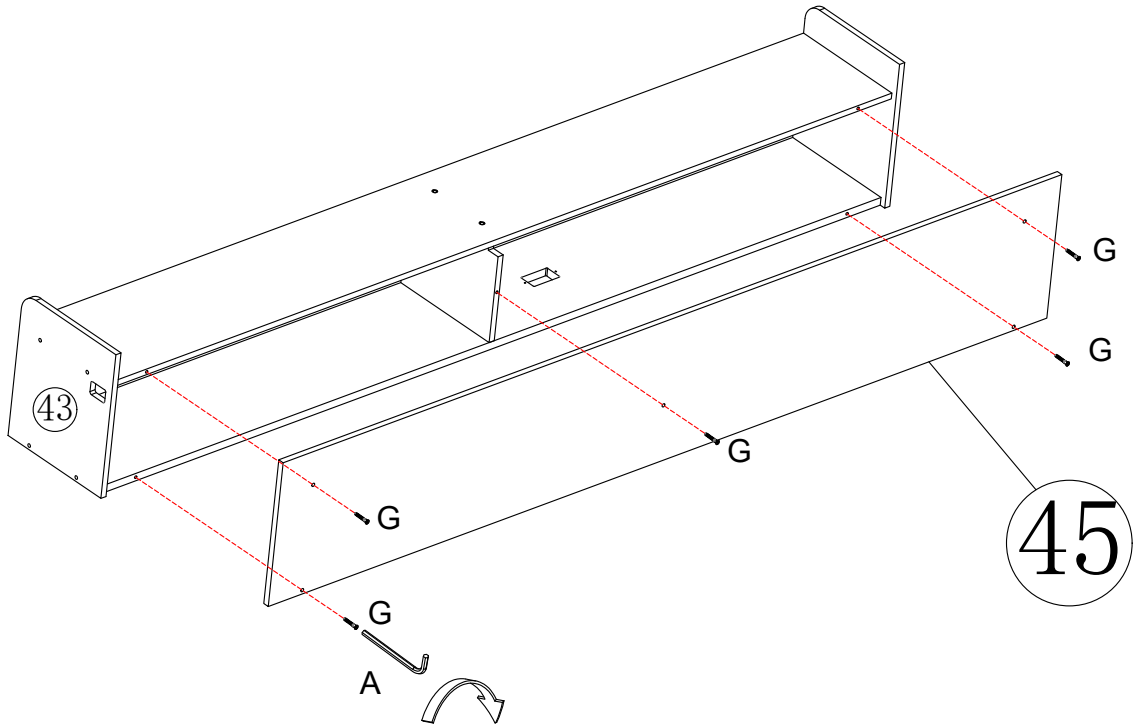

Step 13:

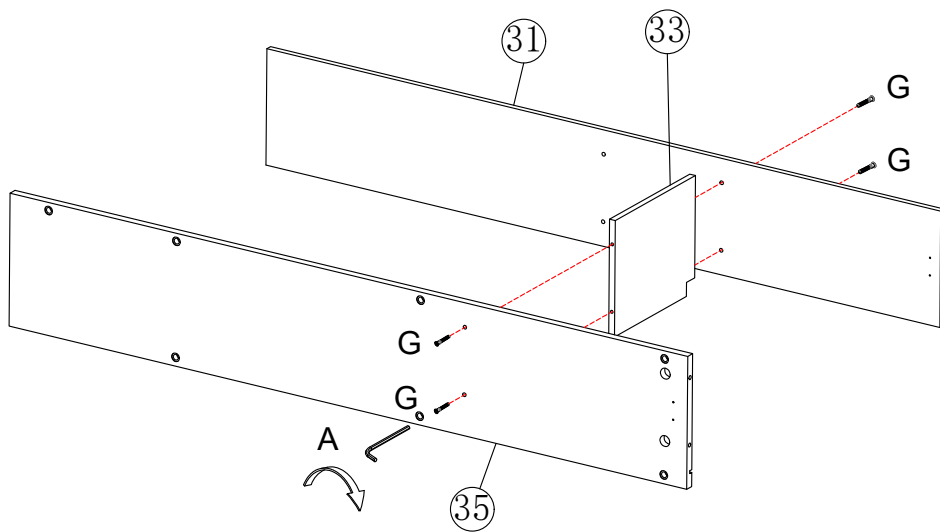

A Allen Key	G Connecting bolt x 5
 M3	 M5x28mm

Step 14:



A Allen Key	G Connecting bolt x 4
 M3	 M5x28mm

Step 15:

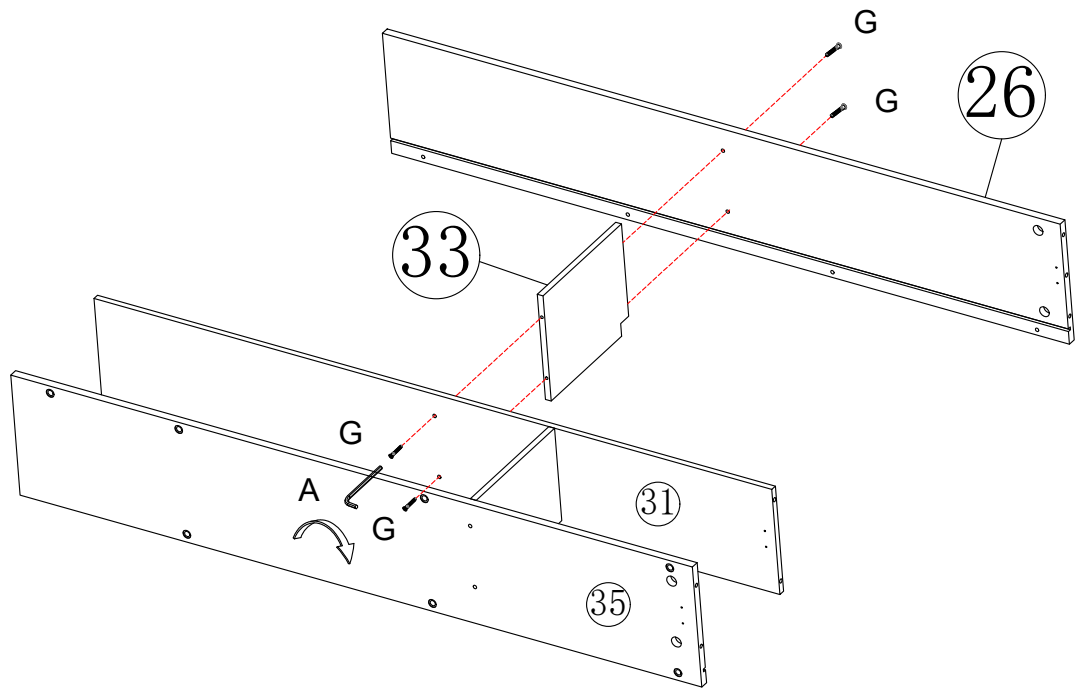

A Allen Key M3	G Connecting bolt x4 M5x28mm
--------------------------	--

Step 16:

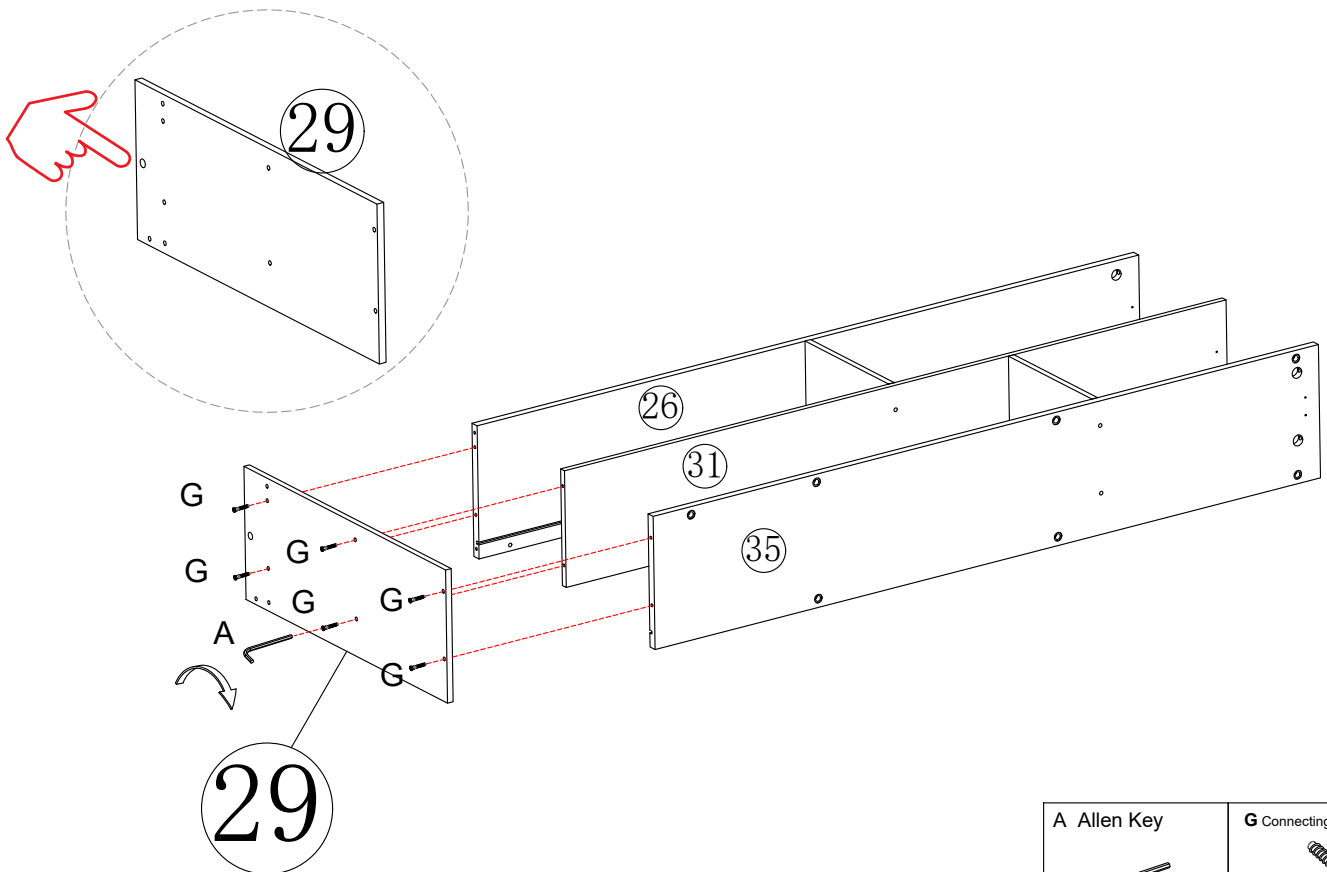

A Allen Key M3	G Connecting bolt x6 M5x28mm
--------------------------	--

Step 17:

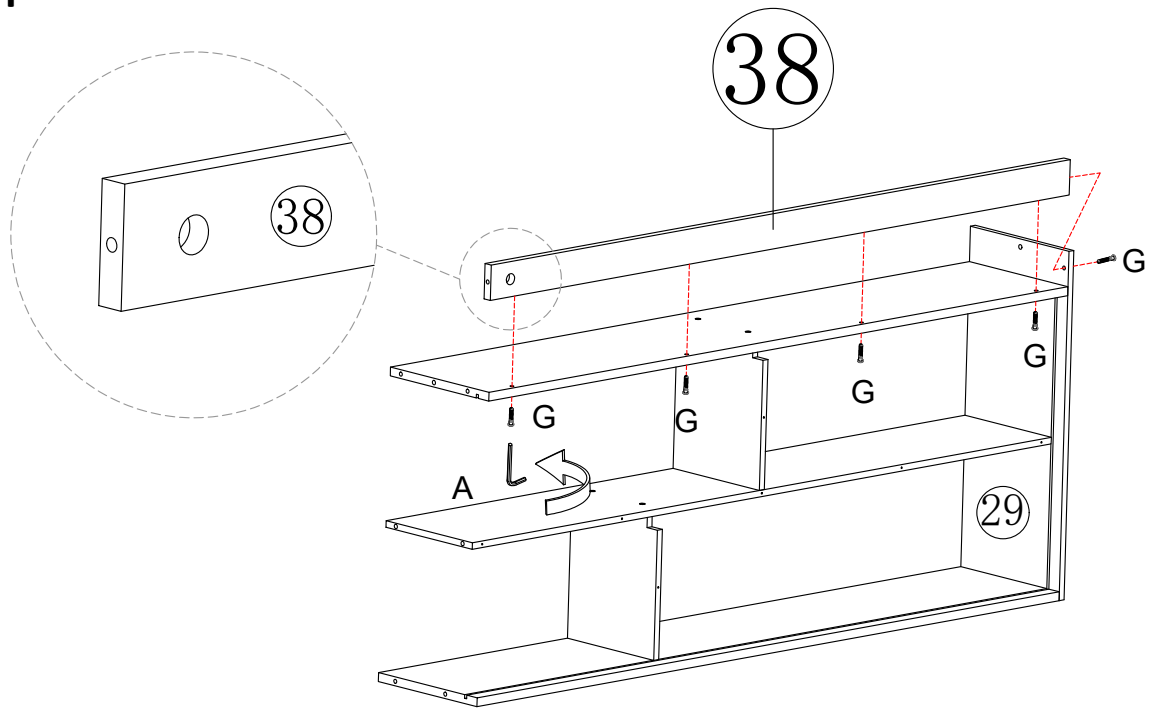

A Allen Key



M3

G Connecting bolt x5



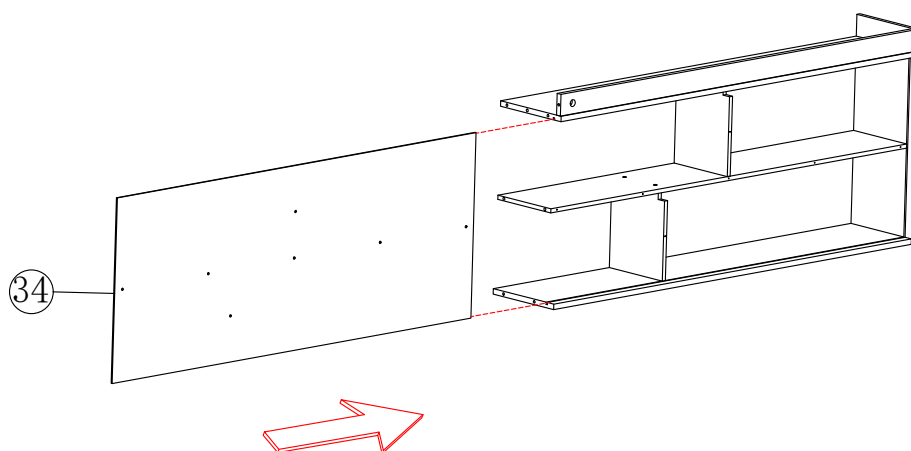

M5x28mm

Step 18:



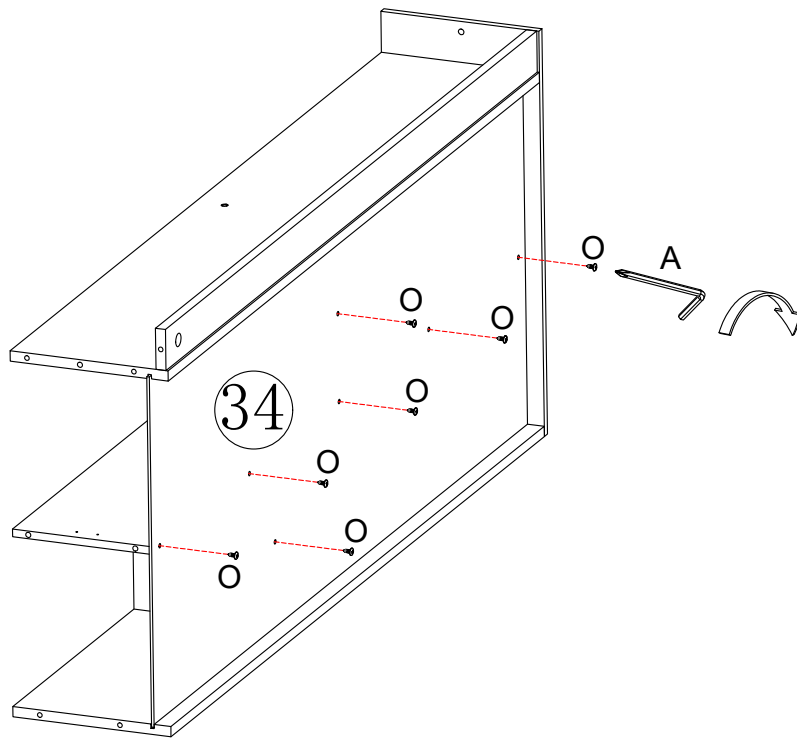

Step 19:

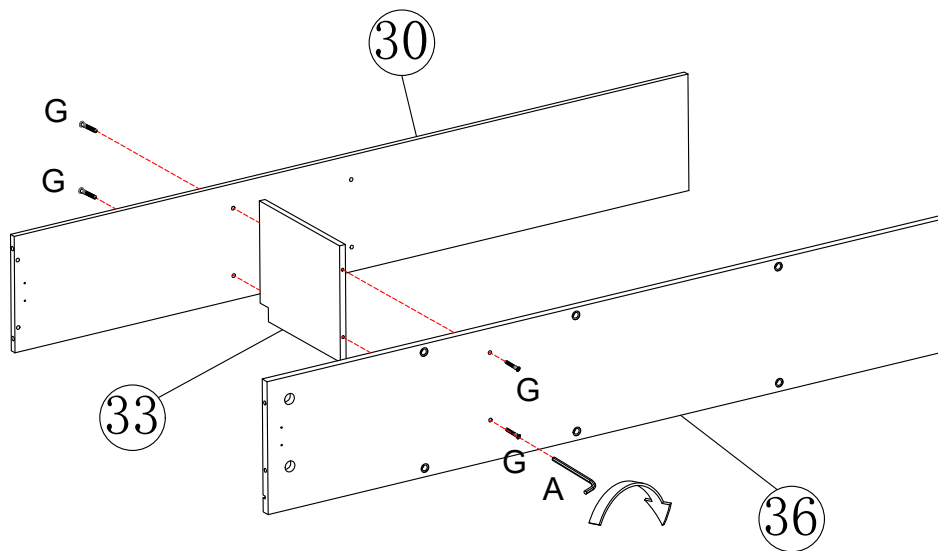

A Allen Key	O Self-tapping screw x 7
 M4	 M4x10mm

Step 20:



A Allen Key	G Connecting bolt x4
 M3	 M5x28mm

Step 21:

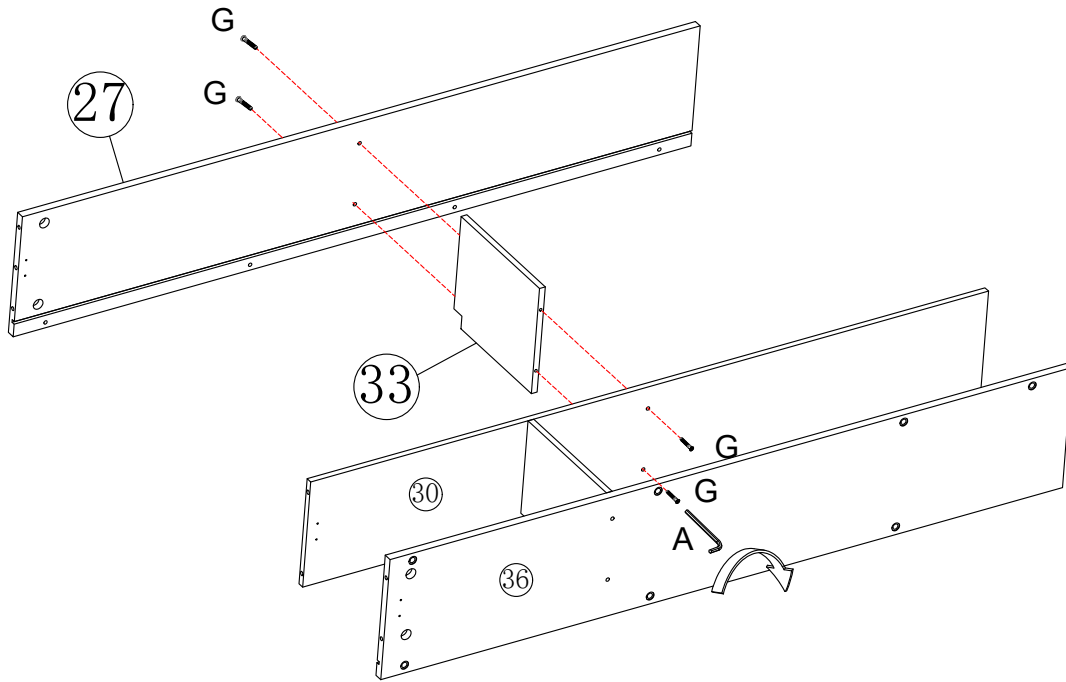

A Allen Key



M3

G Connecting bolt x4



M5x28mm

Step 22:

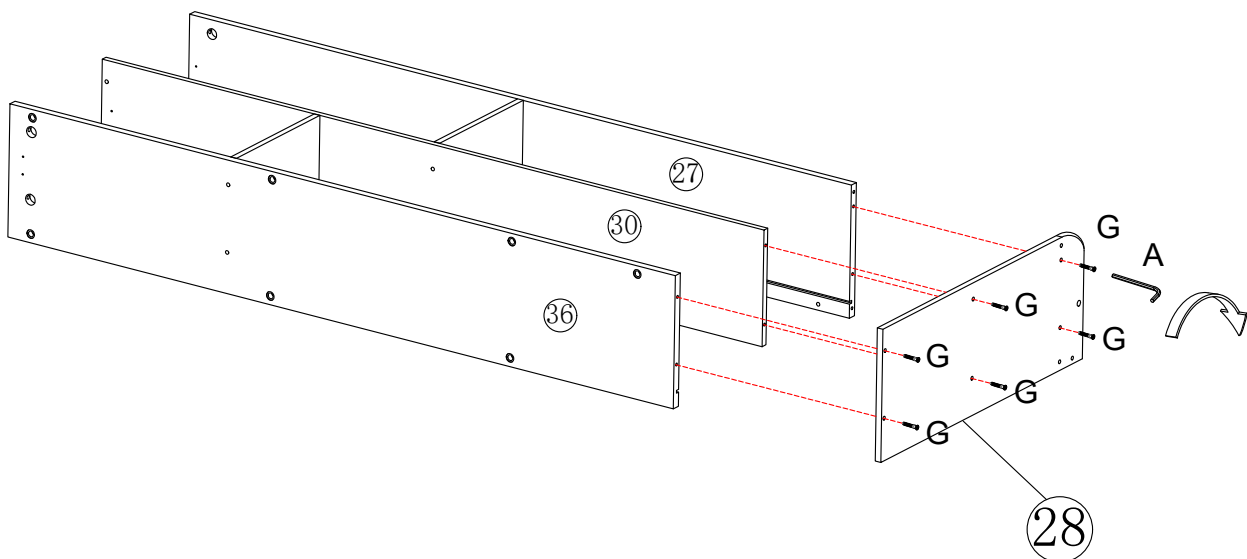

A Allen Key



M3

G Connecting bolt x6



M5x28mm

Step 23:

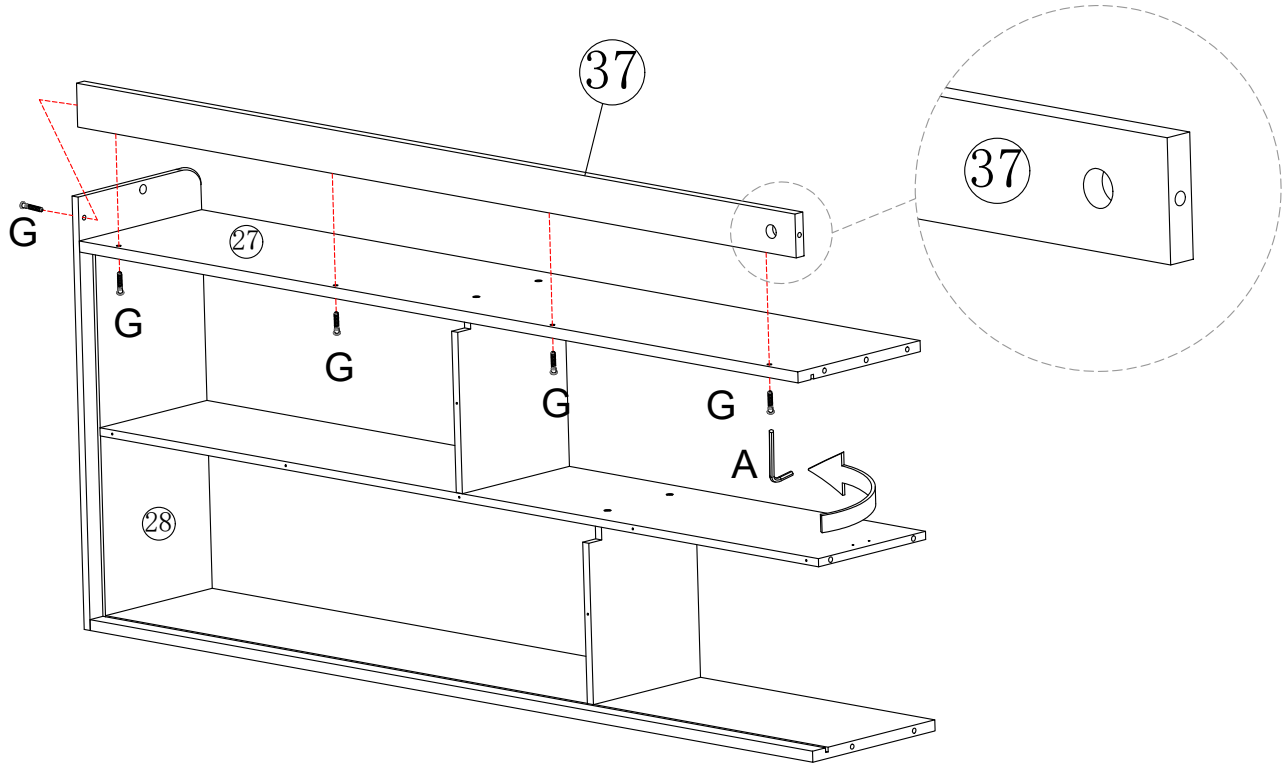

A Allen Key M3	G Connecting bolt x5 M5x28mm
-------------------	---------------------------------

Step 24:

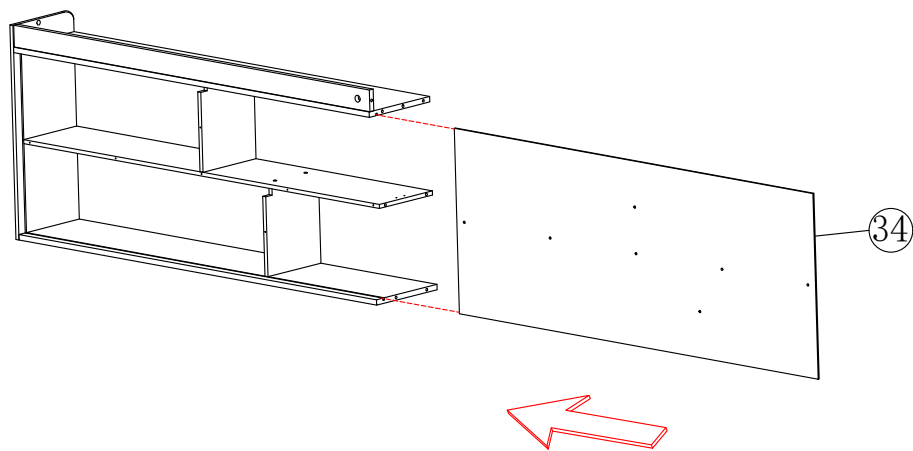

Step 25

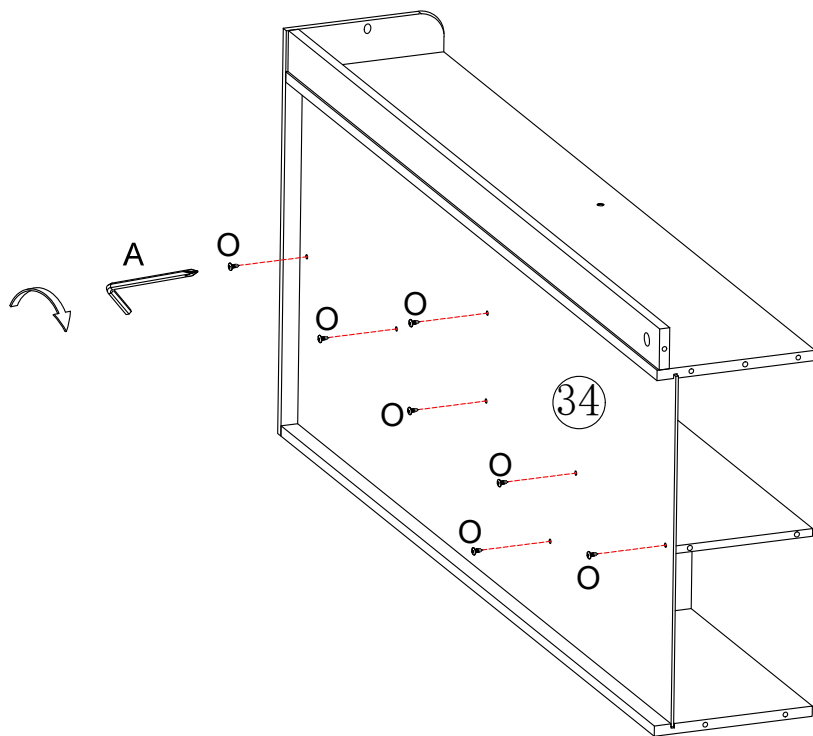

A Allen Key



M4

O Self-tapping screw x 7



M4x10mm

Step 26:

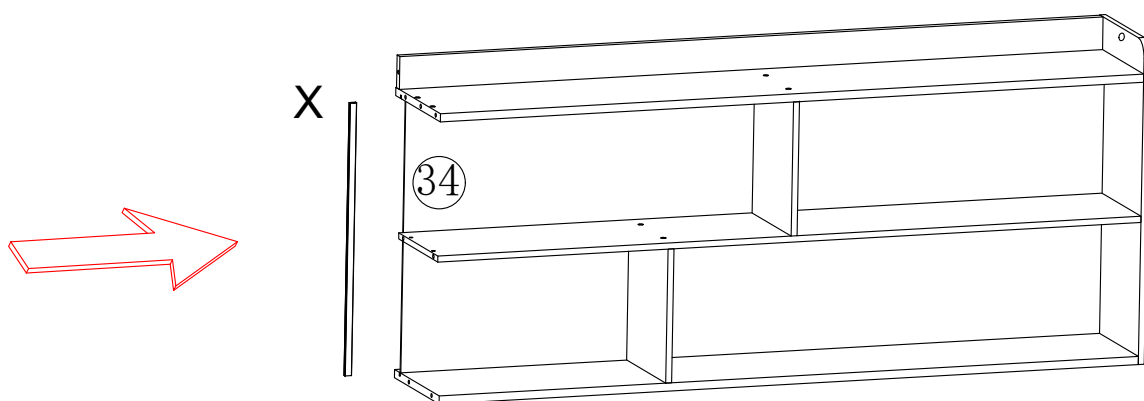

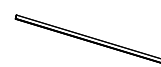

X H-shaped clip strip x1



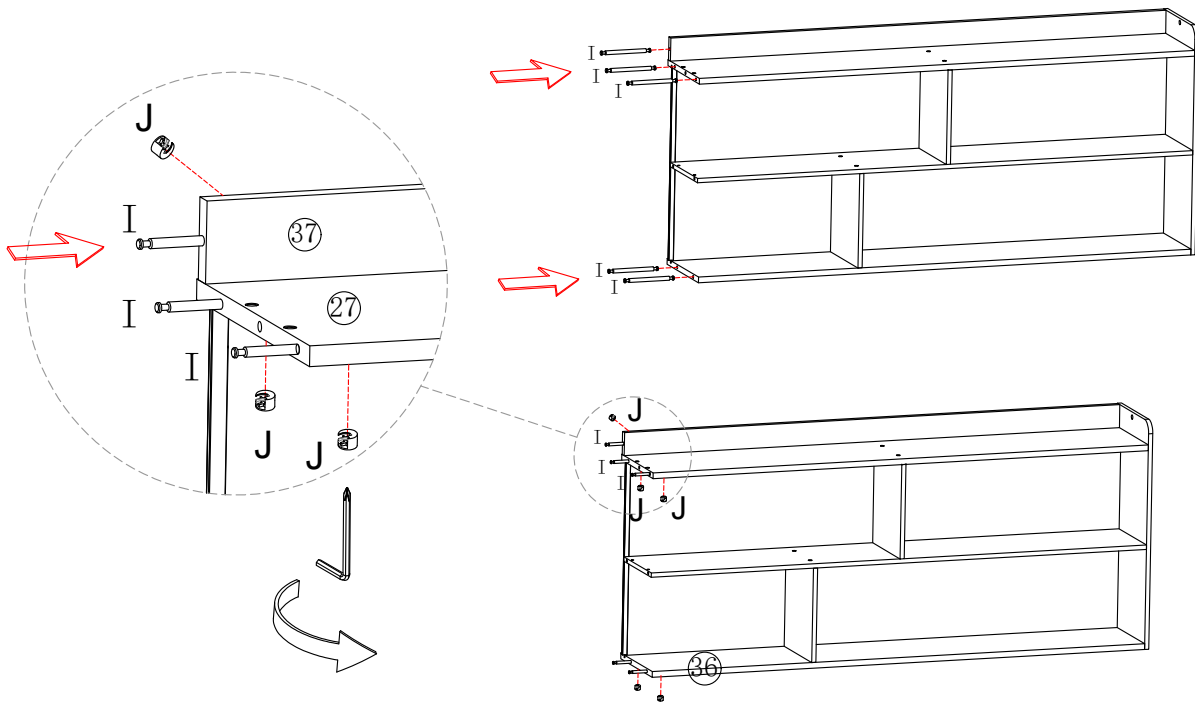

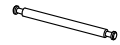
Step 27:

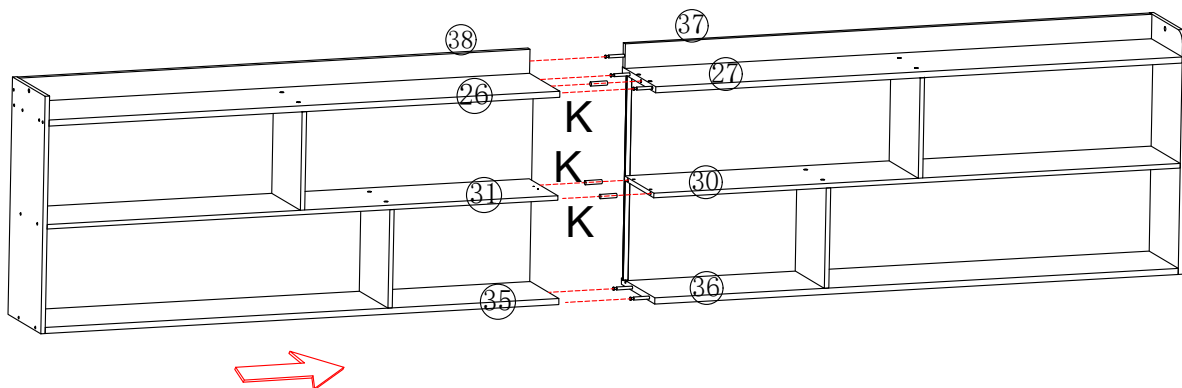

A Allen Key  M4	I Dual-head triple-function x5  Ø5*70	J Eccentric pulley x 5 
--	---	--

Step 28:



K Wooden dowel x3  Ø6*30
--

Step 29:

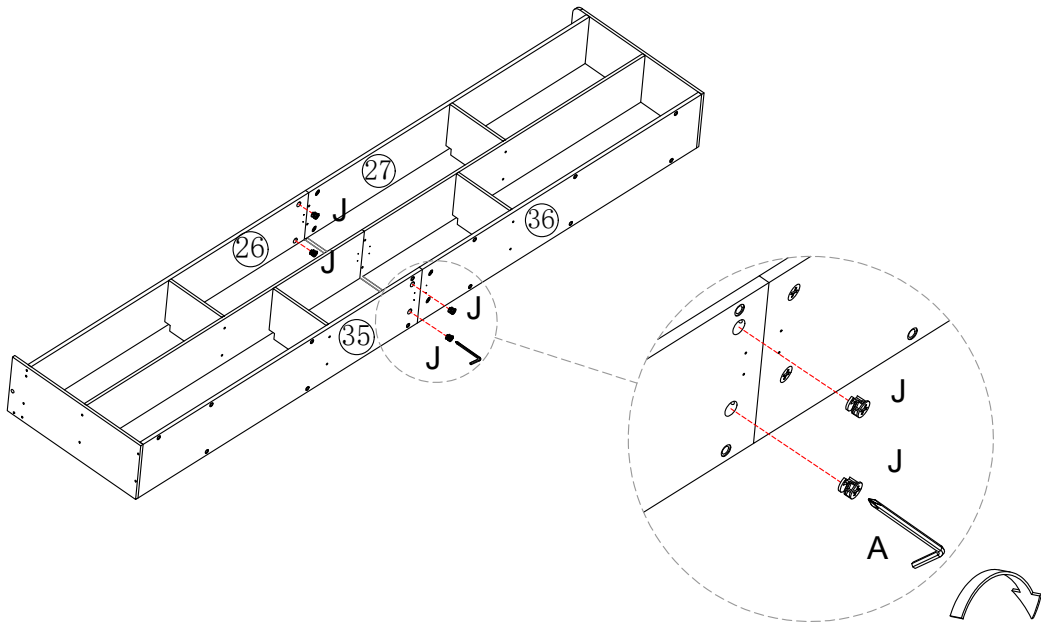

A Allen Key

J Eccentric pulley x 4

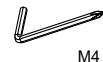

M4



Step 30:

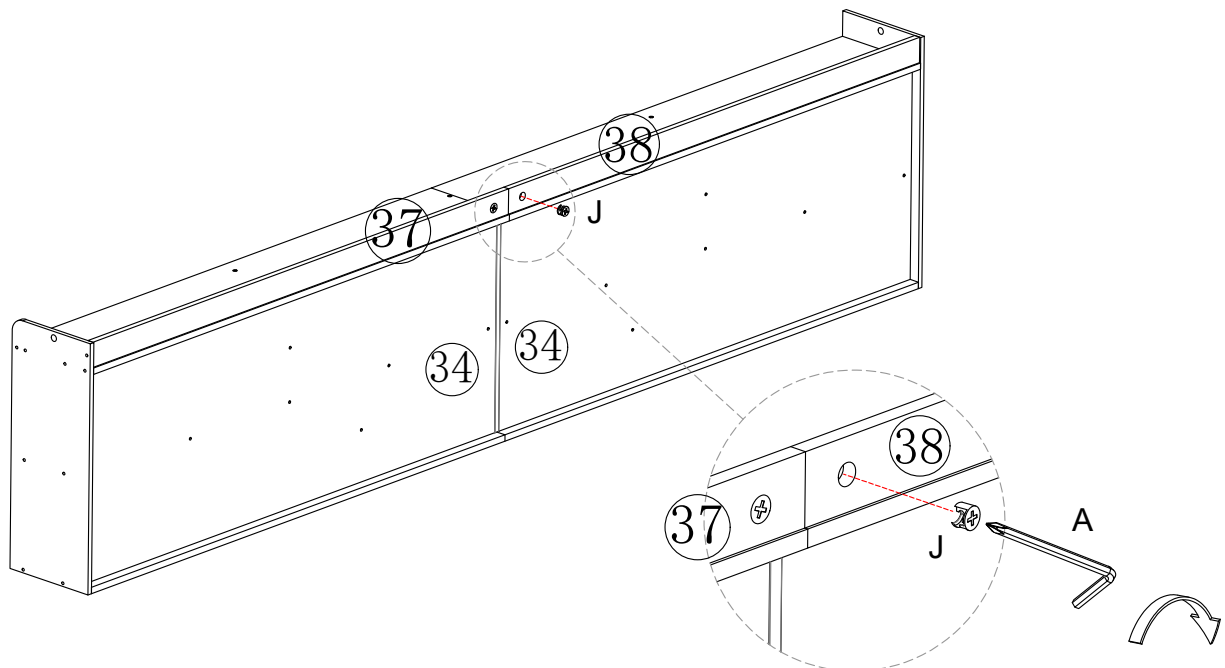

A Allen Key

J Eccentric pulley x 1





M4



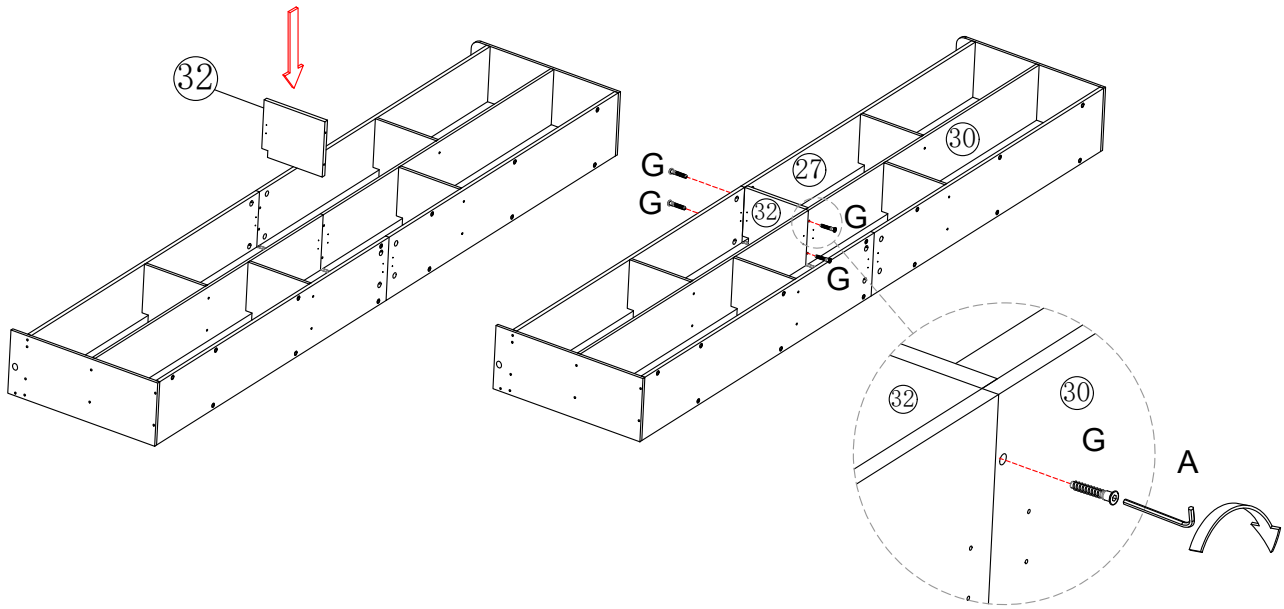



Step 31:

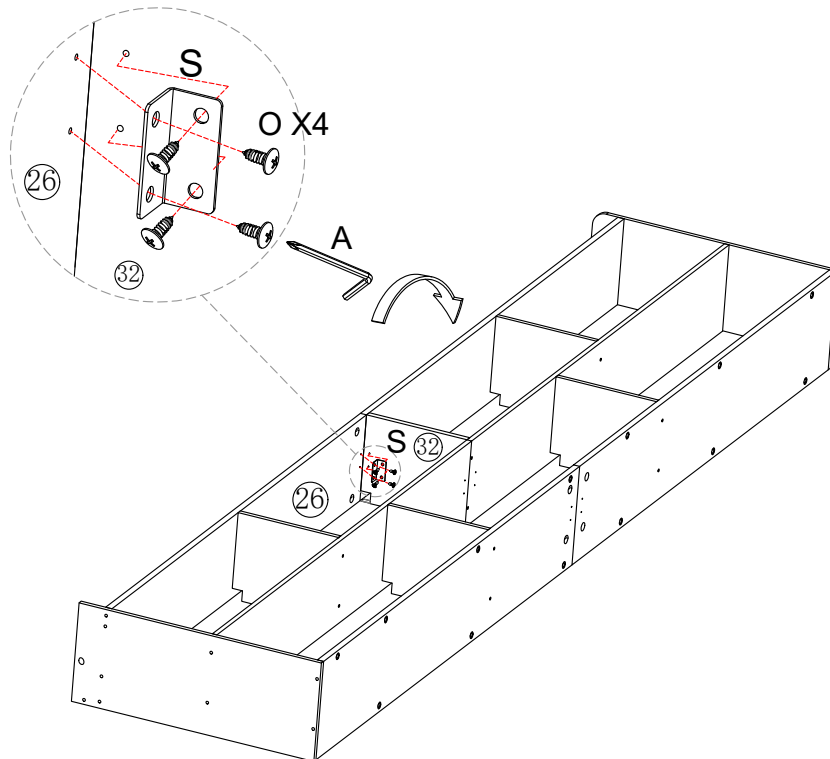

A Allen Key	G Connecting bolt x4
	
M3	M5x28mm



Step 32:



A Allen Key	S Corner bracket x 1	O Self-tapping screw x 4
		
M4		M4x10mm

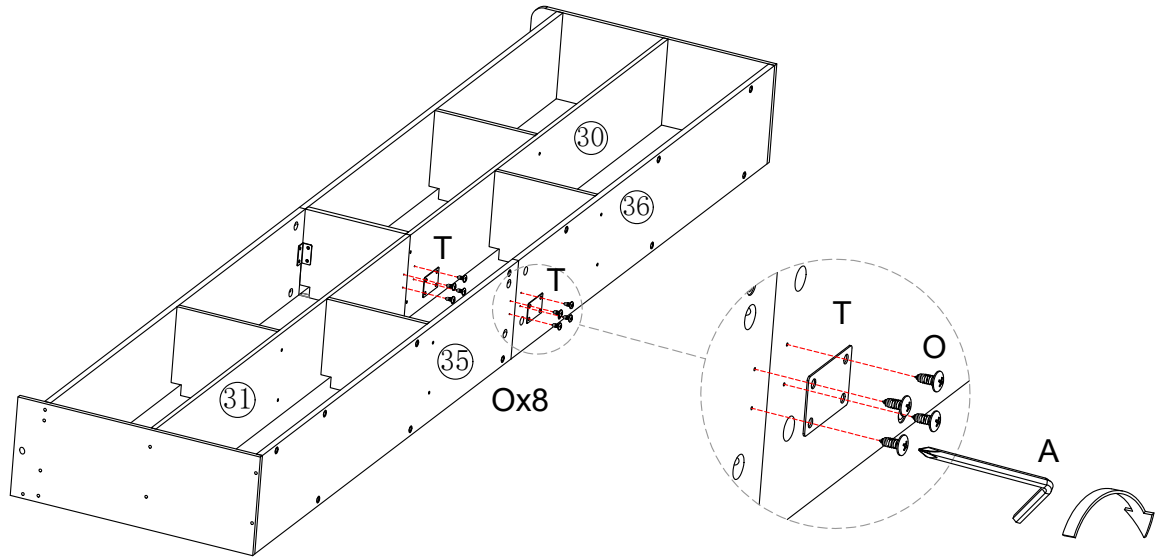



Step 33:

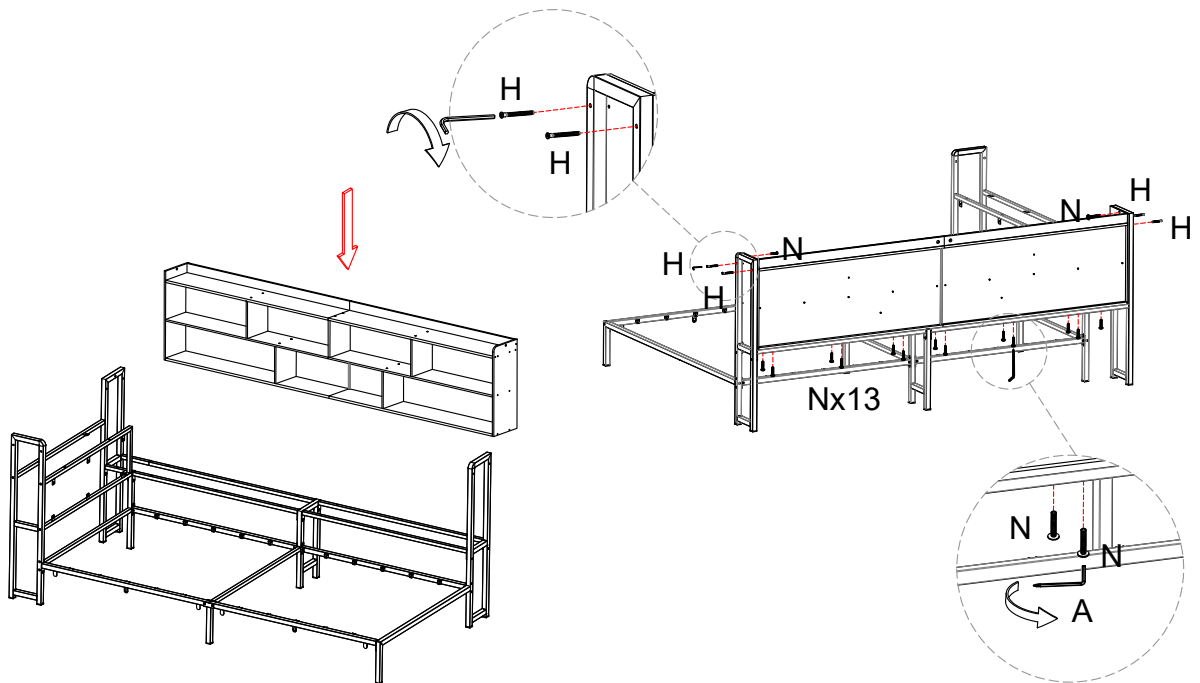

<p>A Allen Key</p>  <p>M4</p>	<p>T Connecting plate x 2</p> 	<p>O Self-tapping screw x 8</p>  <p>M4x10mm</p>
---	---	--





Step 34:

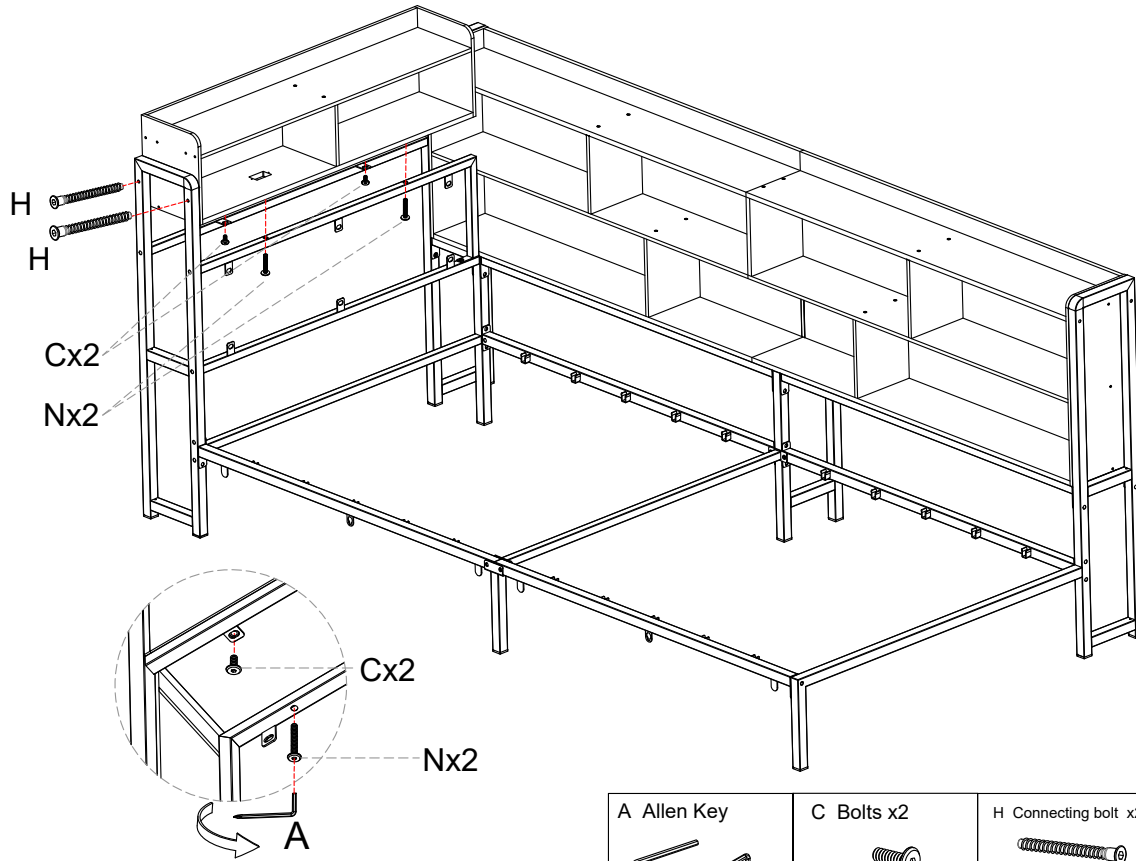

<p>A Allen Key</p>   <p>M3 M4</p>	<p>H Connecting bolt x4</p>  <p>M5x50mm</p>	<p>N Screw x15</p>  <p>M6x28mm</p>
--	--	---



Step 35:

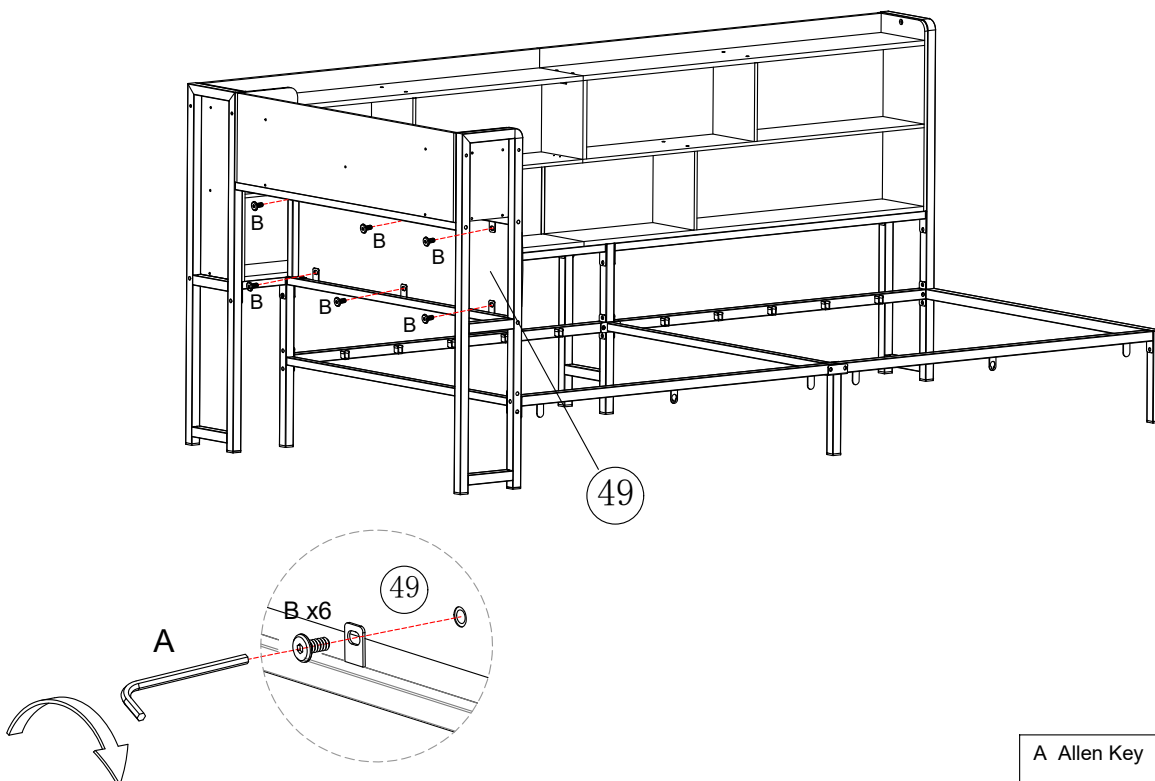

<p>A Allen Key</p>  <p>M3 M4</p>	<p>C Bolts x2</p>  <p>M6x10mm</p>	<p>H Connecting bolt x2</p>  <p>M5x50mm</p>	<p>N Screw x2</p>  <p>M6x28mm</p>
---	--	--	--

Step 36:



<p>A Allen Key</p>  <p>M5</p>	<p>B Bolts x 6</p>  <p>M8x10mm</p>
--	---

Step 37:

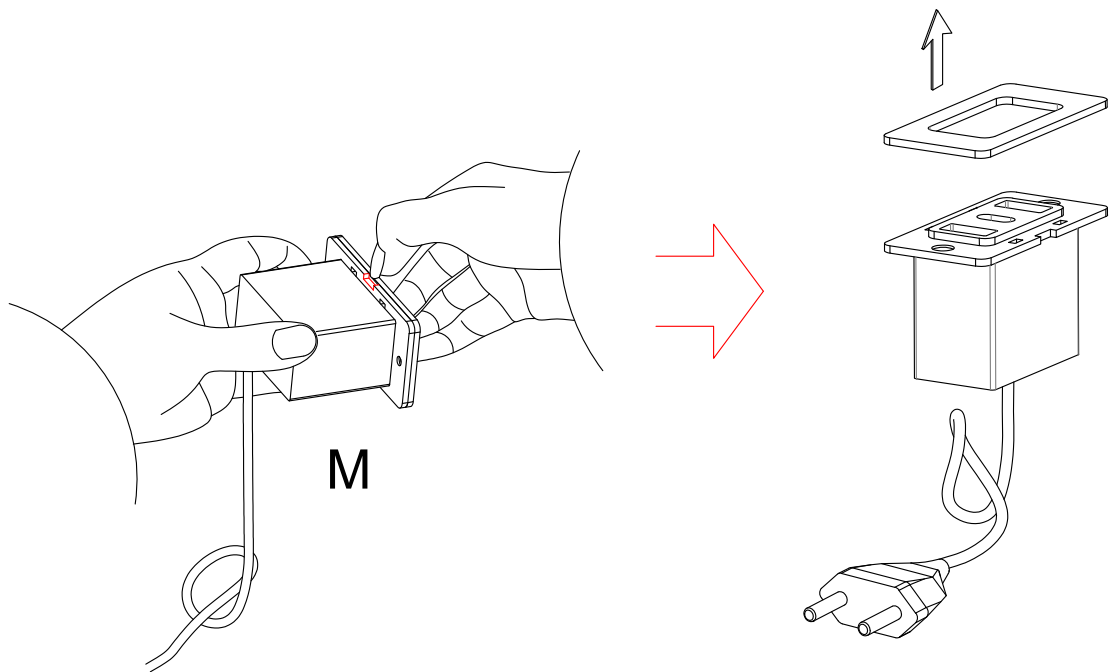

Step 38:

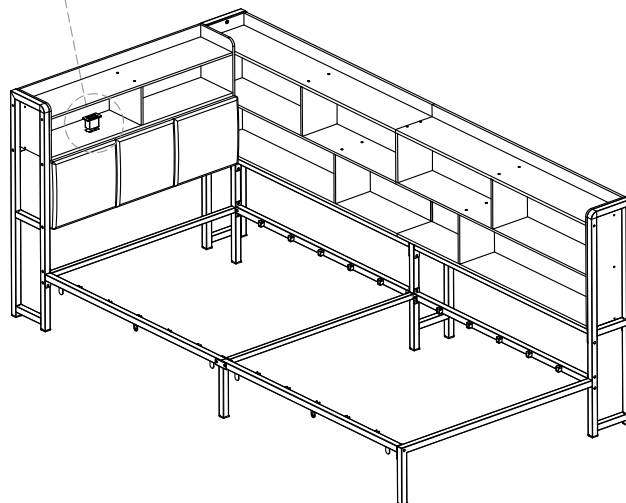
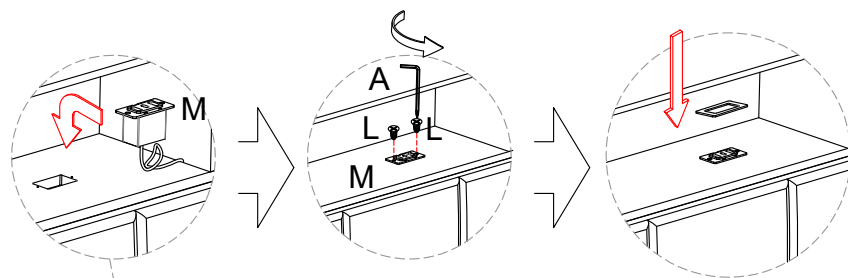

M socket x1



L Self-tapping screw x2



M3x10mm

Step 39:

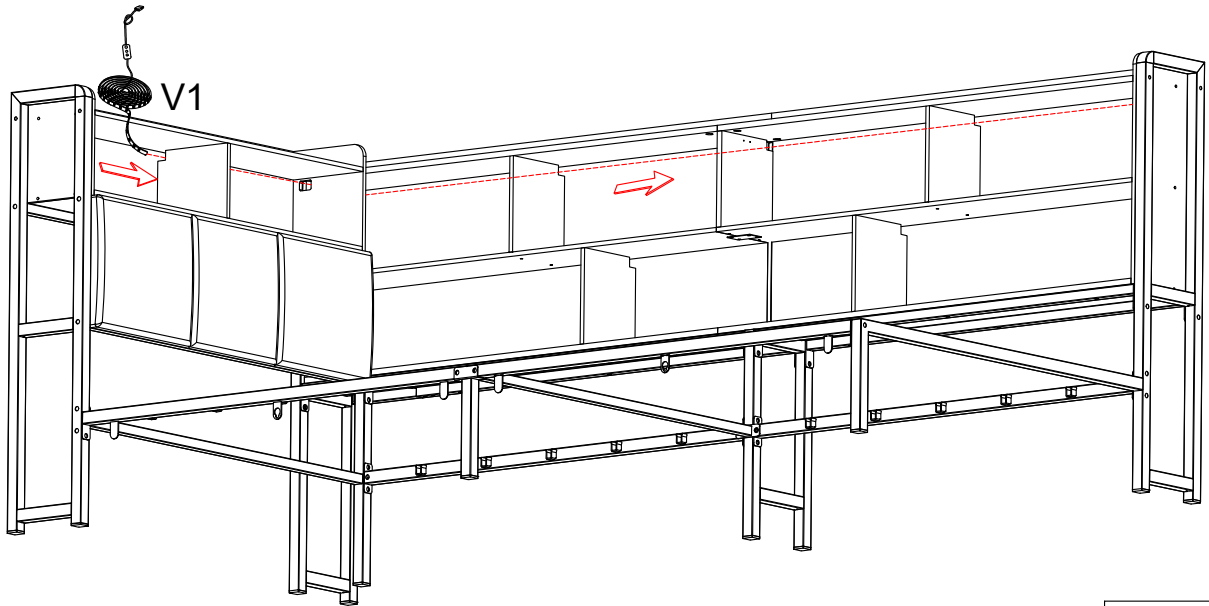

V1 Light strip x1



Step 40:

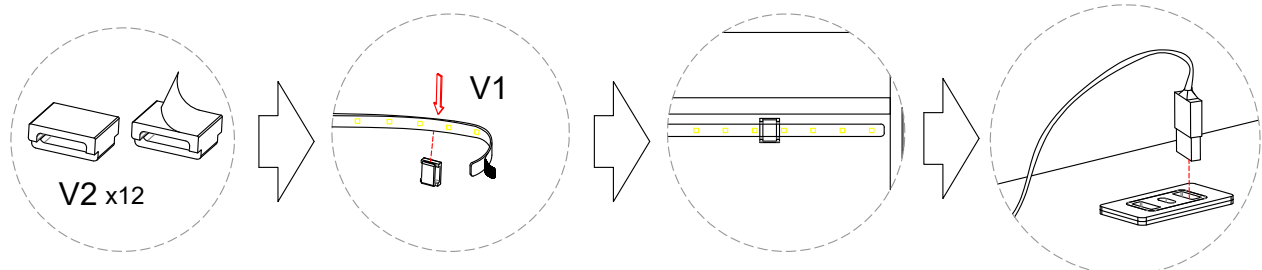
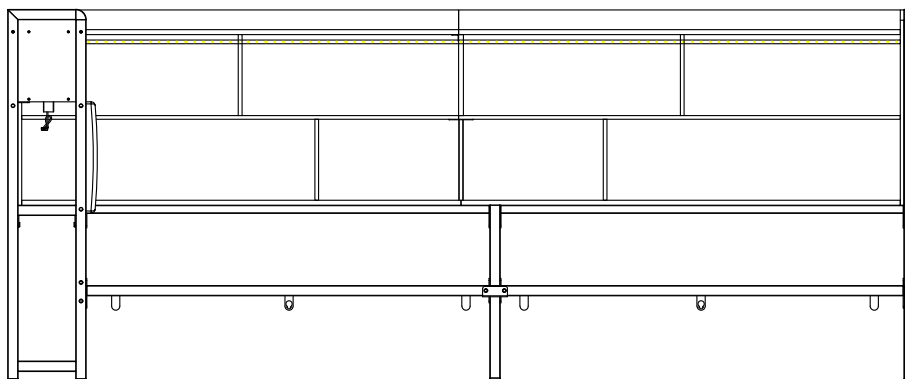

V2 x12

V2 Light strip clips x12



Step 41:

x2

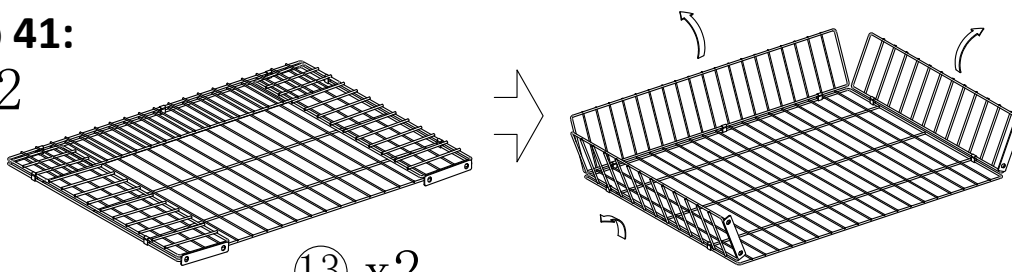

13 x2

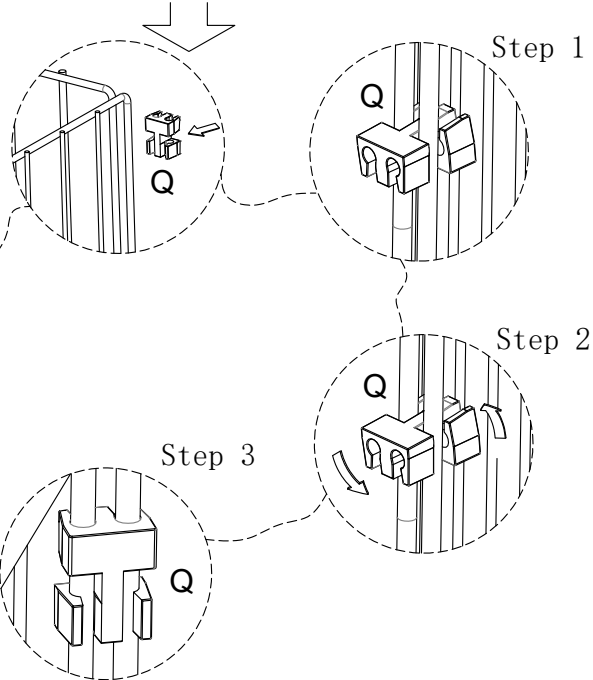
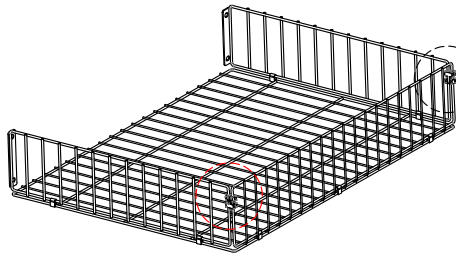

Q Wire clip x4



Step 42:

x2

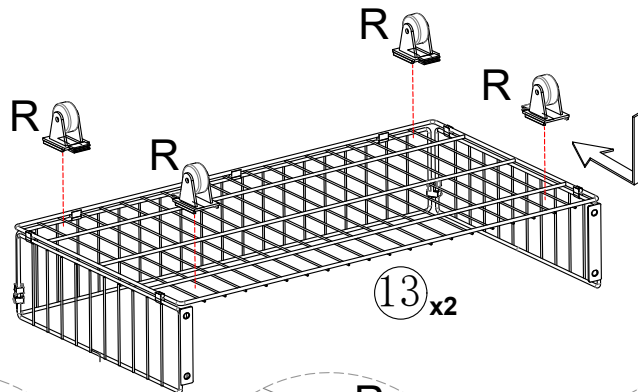

13 x2

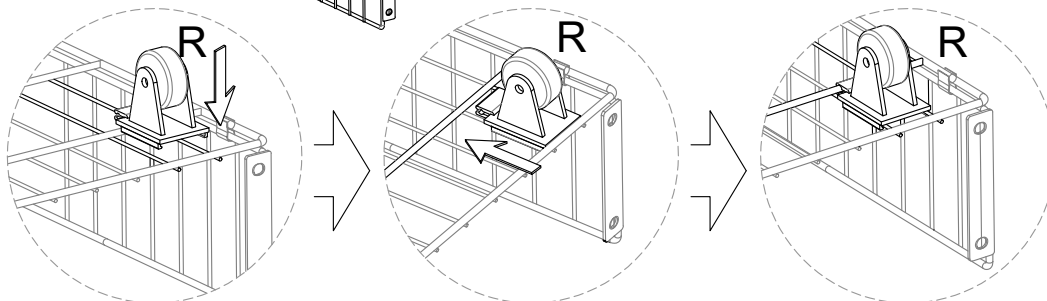





R small wheel x8

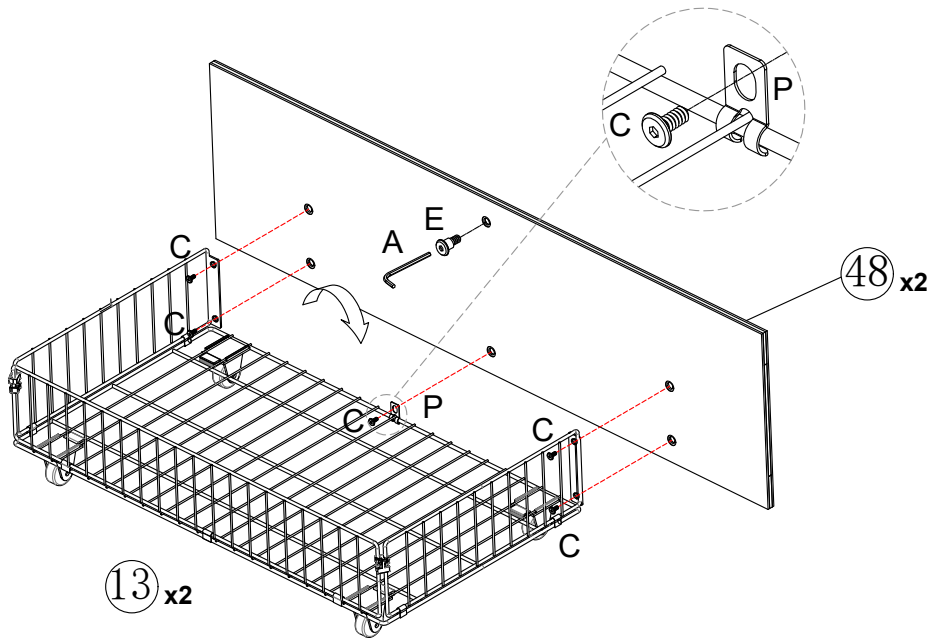

Step 43:
x2



A Allen Key	P Wire clip x2	C Bolts x10	E Positioning screw x2
 M5		 M6x10mm	 M6*10(Ø8*5)

Step 44:

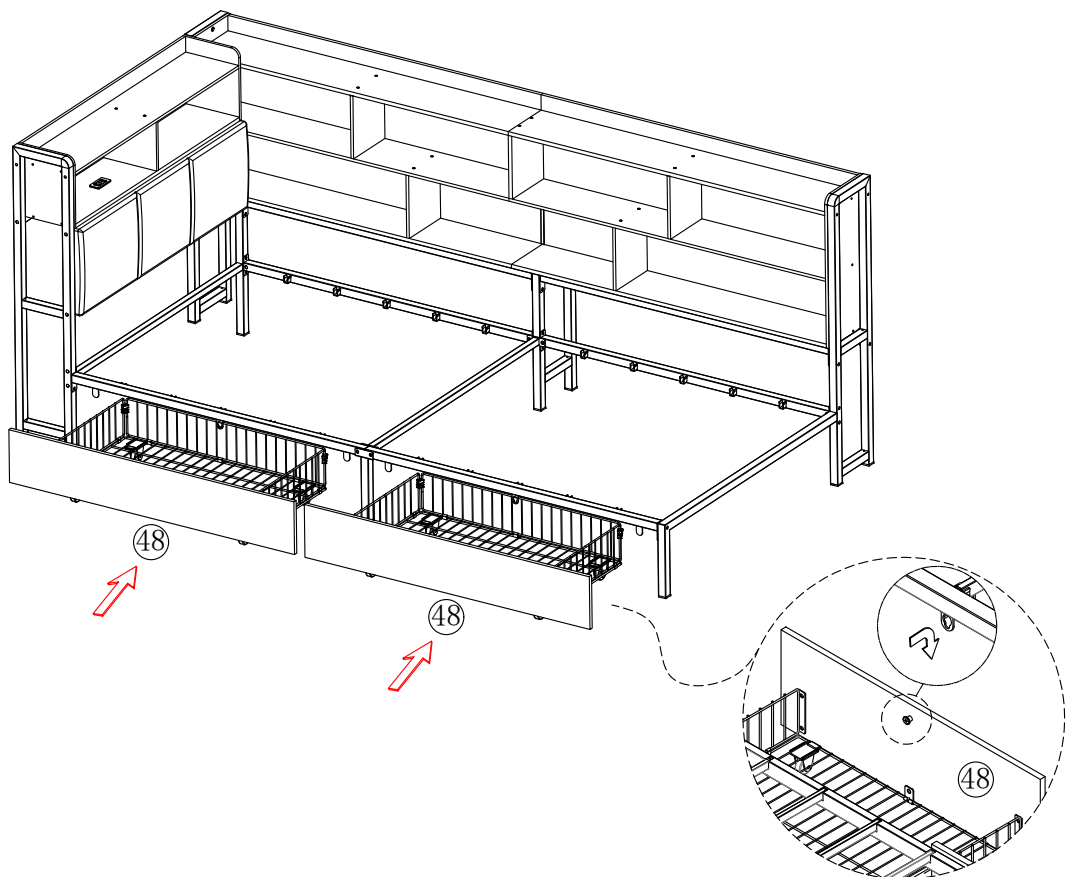

Step 45:

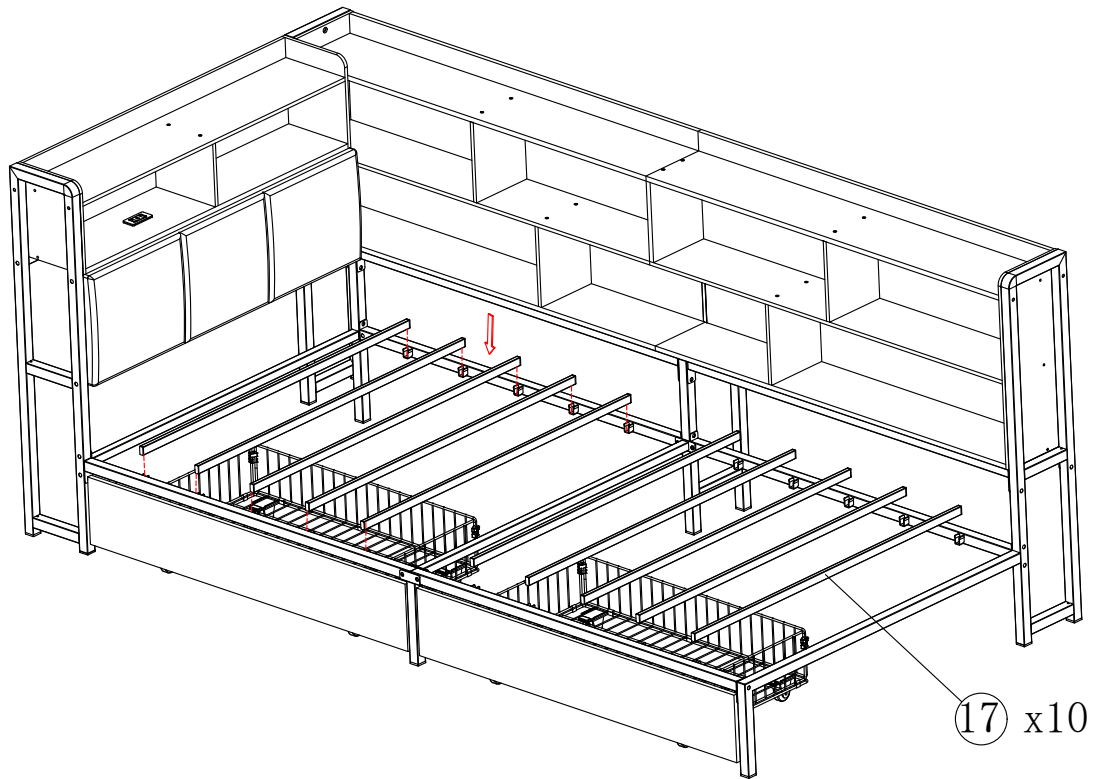

Step 46:

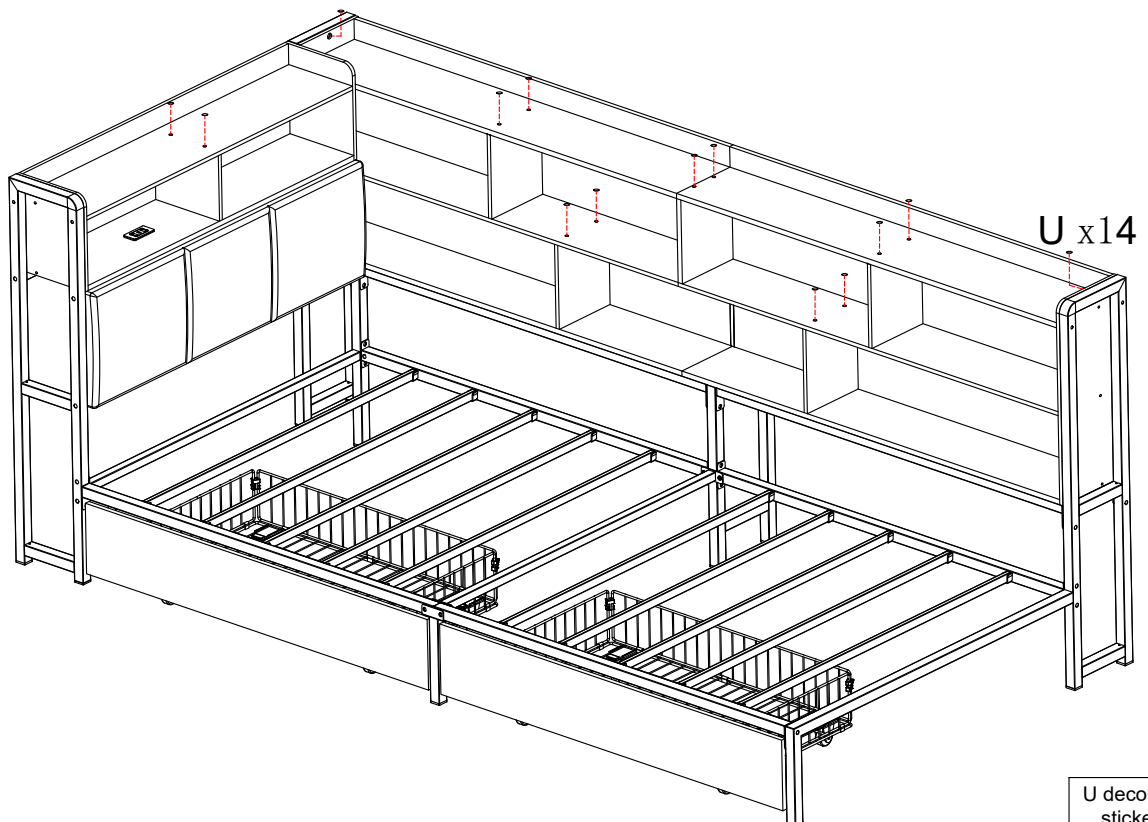

U decorative sticker x 14





Certificate Of Compliance

Certificate No. : BZT252355000416CC-R1
Applicant : Xiamen Zhenlexin Electronic Technology Co., Ltd
Address : 3rd Floor, No. 96, Huli Yuan, Xinmei Sub-district, Tong'an District, Xiamen City
Manufacturer : Xiamen Zhenlexin Electronic Technology Co., Ltd
Address : 3rd Floor, No. 96, Huli Yuan, Xinmei Sub-district, Tong'an District, Xiamen City
Sample Name : Light strip
Model No. : ZLX5050RGB-30D
Additional Model : ZLX5050RGB-60D
Test Standard : IEC 62321-1:2013
IEC 62321-2:2021
IEC 62321-3-1:2013
IEC 62321-4:2013/AMD1:2017
IEC 62321-5:2013
IEC 62321-6:2015
IEC 62321-7-1:2015
IEC 62321-7-2:2017
IEC 62321-8:2017
As shown in the Test Report No. : BZT252355000416CR-R1

The EUT described above has been consolidated by us and found in compliance with the council RoHS 2.0 Directive (EU) 2015/863 and (EU)2017/2102 amending Annex II to Directive 2011/65/EU.
The certificate applies to the tested sample above mentioned only and shall not imply an assessment of the whole production. It is only valid in connection with the test report Number BZT252355000416CR-R1.



Scan QR code
verification of authenticity

CE RoHS



Mark Wen
Technical director
Date: Oct.28,2025

Lab Name : BZT Testing (Dongguan) Co., Ltd.
Lab : 1F, Bangying building, Fuma, Chigang community, Humen Town, Dongguan City,
Address : Guangdong Province, China
BZT http : www.bzt-test.com **Telephone** : +86-0769-81516886
Confirm the authenticity of Test reports Email: bzt@bzt-test.com