

SKU N621P 451588 / N621P 451589

Our product will be delivered to you in 2 packages. The delivery times of these 2 packages may differ, please be patient and thank you for your understanding.

Unser Produkt wird Ihnen in 2 Paketen geliefert. Die Lieferzeiten dieser 2 Pakete können abweichen, bitte haben Sie etwas Geduld und vielen Dank für Ihr Verständnis.

Notre produit vous sera livré en 2 colis. Les délais de livraison de ces 2 colis peuvent différer, soyez patient et merci de votre compréhension.

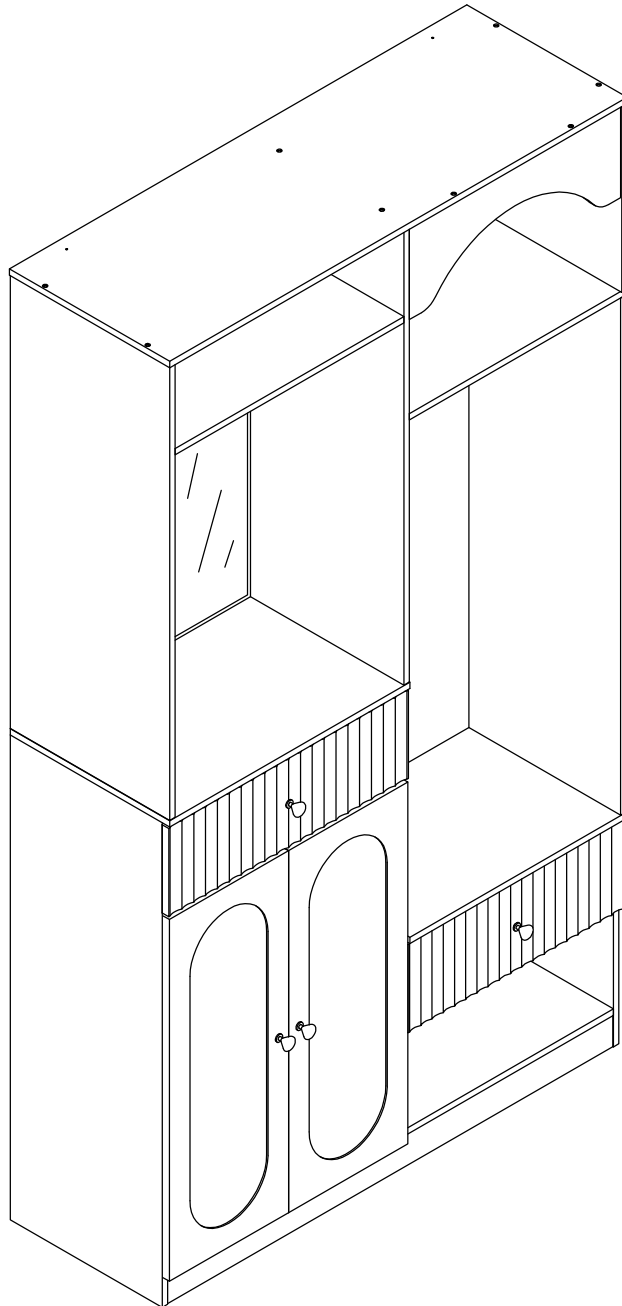

EN IMPORTANT, RETAIN FOR FUTURE REFERENCE: READ CAREFULLY.
FR IMPORTANT: ALIRE ATTENTIVEMENT ET A CONSERVER POUR
CONSULTATION ULTERIEURE.

ES IMPORTANTE, LEA GUARDE PARA FUTURAS REFERENCIAS.

DE WICHTIG! SORGFÄLTIG LESEN UND FÜR SPÄTER
NACHSCHLAGENAUFBEWAHREN.

IT IMPORTANTE! CONSERVARE IL PRESENTE MANUALE PER FUTURO
RIFERIMENTO ELEGGERLO ATTENTAMENTE.



DE

Warnung: Die maximale Belastbarkeit dieses Möbels beträgt: 100 kg, bitte nicht überlasten!

EN

Warning: The maximum load-bearing capacity of this furniture is: 100 kg, please do not overload!

FR

Avertissement : La capacité de charge maximale de ce meuble est de : 100 kg, merci de ne pas surcharger !

IT

Attenzione: la capacità di carico massima di questo mobile è: 100 kg, non sovraccaricare!

ES

Advertencia: La capacidad máxima de carga de este mueble es: 100 kg, ¡no lo sobrecargue!



[DE]

Warnung: Lesen Sie die Anleitung vor dem Zusammenbau bitte vollständig durch. Überprüfen Sie, ob Sie alle auf den Seiten aufgeführten Komponenten und Werkzeuge haben.

Warnung: Legen Sie alle Teile auf eine ebene Fläche. Legen Sie eine weiche Decke oder Ähnliches darunter, um sie vor Kratzern oder Flecken zu schützen. Vermeiden Sie es, Komponenten über den Boden zu ziehen oder zu schieben.

Warnung: Überprüfen Sie regelmäßig alle Beschläge und Befestigungen, um sicherzustellen, dass sie sicher sind und um Unfälle zu vermeiden. Wenn Teile fehlen, kaputt, beschädigt oder abgenutzt sind, verwenden Sie das Produkt nicht weiter, bis es mit vom Hersteller autorisierten Teilen repariert wurde.

Warnung: Lassen Sie Kinder nicht auf die Möbel klettern, da dies zum Umkippen und zu schweren Verletzungen führen kann. Bauen Sie die Möbel außerhalb der Reichweite von Kindern zusammen.

Warnung: Stellen Sie die Möbel nicht in die Nähe von Feuerquellen oder heißen Gegenständen, um Brandgefahr zu vermeiden.

Warnung: Reinigen Sie die Möbel mit einem feuchten Tuch oder Alkohol. Verwenden Sie keine Reinigungsmittel mit ätzenden Chemikalien.

Warnung: Dieses Produkt ist mit einer Kippschutzvorrichtung ausgestattet. Bitte installieren Sie diese Vorrichtung unbedingt, um unnötige Verletzungen durch Umkippen zu vermeiden.

[EN]

Warning: Please read instructions fully before starting assembly. Check you have all the components and tools listed on pages.

Warning: Please place all parts on a flat surface. Place a soft blanket or similar underneath to protect against scratches or stains. Avoid dragging or sliding components across the floor.

Warning: Regularly check all fittings and fastenings to ensure they are secure and to prevent accidents. If any parts are missing, broken, damaged, or worn, discontinue use of the product until repairs have been made using factory authorized parts.

Warning: Do not allow children to climb on the furniture as this may result in tipping and serious personal injury. Assemble the furniture away from the reach of children.

Warning: Do not place furniture close to fire sources or high-temperature objects to avoid the risk of fire.

Warning: Clean furniture with a damp cloth or alcohol, avoid using cleaning agents containing corrosive chemicals.

Warning: This product is equipped with an anti-tilt device. Please be sure to install this device to prevent unnecessary injuries caused by tipping.

[FR]

Avertissement : Veuillez lire entièrement les instructions avant de commencer l'assemblage. Vérifiez que vous disposez de tous les composants et outils répertoriés sur les pages.

Avertissement : Veuillez placer toutes les pièces sur une surface plane. Placez une couverture douce ou similaire en dessous pour les protéger des rayures ou des taches. Évitez de faire glisser les composants sur le sol.

Avertissement : Vérifiez régulièrement tous les raccords et fixations pour vous assurer qu'ils sont bien fixés et pour éviter les accidents. Si des pièces manquent, sont cassées, endommagées ou usées, cessez d'utiliser le produit jusqu'à ce que des réparations aient été effectuées à l'aide de pièces autorisées par l'usine.

Avertissement : Ne laissez pas les enfants grimper sur les meubles car cela pourrait entraîner un basculement et des blessures graves. Assemblez les meubles hors de portée des enfants.

Avertissement : Ne placez pas les meubles à proximité de sources de feu ou d'objets à haute température pour éviter tout risque d'incendie.



Avertissement : Nettoyez les meubles avec un chiffon humide ou de l'alcool, évitez d'utiliser des produits de nettoyage contenant des produits chimiques corrosifs.

Avertissement : Ce produit est équipé d'un dispositif anti-basculement. Assurez-vous d'installer ce dispositif pour éviter les blessures inutiles causées par un basculement.

[IT]

Attenzione: leggere attentamente le istruzioni prima di iniziare il montaggio. Verificare di avere tutti i componenti e gli strumenti elencati nelle pagine.

Attenzione: posizionare tutte le parti su una superficie piana. Posizionare una coperta morbida o simile sotto per proteggere da graffi o macchie. Evitare di trascinare o far scivolare i componenti sul pavimento.

Attenzione: controllare regolarmente tutti i raccordi e i dispositivi di fissaggio per assicurarsi che siano sicuri e per prevenire incidenti. Se alcune parti sono mancanti, rotte, danneggiate o usurate, interrompere l'uso del prodotto fino a quando non siano state eseguite le riparazioni utilizzando parti autorizzate dalla fabbrica.

Attenzione: non consentire ai bambini di arrampicarsi sui mobili poiché ciò potrebbe causare ribaltamenti e gravi lesioni personali. Montare i mobili lontano dalla portata dei bambini.

Attenzione: non posizionare i mobili vicino a fonti di fuoco o oggetti ad alta temperatura per evitare il rischio di incendio.

Attenzione: pulire i mobili con un panno umido o alcol, evitare di utilizzare detergenti contenenti sostanze chimiche corrosive.

Attenzione: questo prodotto è dotato di un dispositivo antiribaltamento. Assicurarsi di installare questo dispositivo per prevenire lesioni inutili causate dal ribaltamento.

[ES]

Advertencia: Lea las instrucciones completamente antes de comenzar el montaje. Compruebe que tiene todos los componentes y herramientas que se enumeran en las páginas.

Advertencia: Coloque todas las piezas sobre una superficie plana. Coloque una manta suave o algo similar debajo para protegerlas de rayones o manchas. Evite arrastrar o deslizar los componentes por el piso.

Advertencia: Verifique regularmente todos los accesorios y fijaciones para asegurarse de que estén seguros y evitar accidentes. Si falta alguna pieza, está rota, dañada o desgastada, deje de usar el producto hasta que se hayan realizado las reparaciones con piezas autorizadas de fábrica.

Advertencia: No permita que los niños se suban a los muebles, ya que esto puede provocar que se vuelquen y lesiones personales graves. Monte los muebles fuera del alcance de los niños.

Advertencia: No coloque los muebles cerca de fuentes de fuego u objetos de alta temperatura para evitar el riesgo de incendio.

Advertencia: Limpie los muebles con un paño húmedo o alcohol, evite usar agentes de limpieza que contengan químicos corrosivos.

Advertencia: Este producto está equipado con un dispositivo antivuelco. Asegúrese de instalar este dispositivo para evitar lesiones innecesarias causadas por vuelcos.

Importeur	Decobus Handel GmbH		
Adresse	Innungsstraße 9, 21244 Buchholz, Deutschland		
Email/URL	https://www.decobusgroup.de		
Hersteller	QINLONG HOUSEHOLD CO., LIMITED		
Adresse	FLAT 2401-16WING SHING IND BLDG 26 NG FONG ST SAN PO KONG HONGKONG		
Email/URL	qinlong0701@163.com		
Partienummer	N621P451588/N621P451589		
Hergestellt in	China		
<table border="1"><tr><td>EC</td><td>REP</td></tr></table>	EC	REP	Decobus Handel GmbH Innungsstraße 9, 21244 Buchholz, Deutschland https://www.decobusgroup.de
EC	REP		

EN

Dear customer,

Thank you for purchasing this product. So that your appliance serves you well, please read all the instructions in this user's manual. If you have any questions, please contact our customer care center.

FR

Cher client,

Nous vous remercions d'avoir acheté ce produit. Afin que vous puissiez profiter pleinement de votre appareil, veuillez lire toutes les instructions de ce manuel d'utilisation. Si vous avez la moindre question, veuillez contacter notre centre d'assistance à la clientèle.

DE

Sehr geehrter Kunde,

Vielen Dank, dass Sie dieses Produkt erworben haben. Damit Ihr Gerät Ihnen gute Dienste leistet, lesen Sie bitte alle Hinweise in diesem Benutzerhandbuch. Wenn Sie Fragen haben, wenden Sie sich bitte an unser Kundendienstzentrum.

ES

Queridos clientes,

Gracias por comprar este producto. Para que su electrodoméstico le sirva mejor, lea todas las instrucciones de este manual del usuario. Si tiene alguna pregunta, comuníquese con nuestro Centro de Atención al Cliente.

IT

Caro Cliente,

Grazie per aver acquistato questo prodotto. Per servirti meglio con questo apparecchio ti prego di leggere tutte le istruzioni in presente manuale utente. In caso di dubbio, si prega di contattare il nostro centro assistenza clienti.

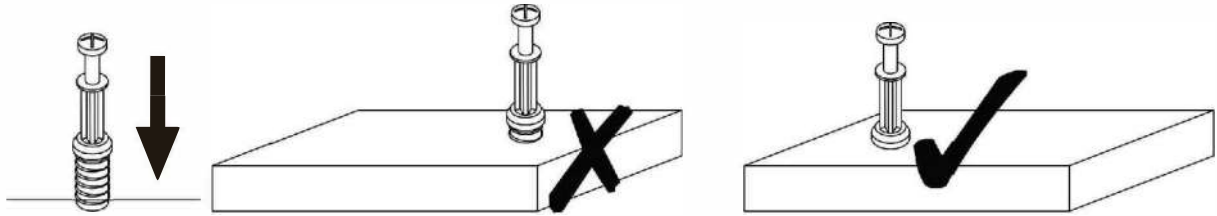

EN_QUICKFIT: Tighten quickfit until shoulder is flush with panel. Do not overtighten or undertighten.

FR_RACCORD RAPIDE: Faites serrer le raccord rapide jusqu'à ce que l'épaule soit parfaitement encastré dans le panneau. Il ne faut ni trop serrer ni insuffisamment serrer.

ES_QUICKFIT: Apriete quickfit hasta que el hombro se descargue con el panel. NO lo sobreapriete ni lo apriete poco.

DE_QUICKFIT: Ziehen Sie den Quickfit fest, bis die Schulter mit der Platte bündig ist. Bitte nicht zu fest oder zu schwach anziehen.

IT_MONTAGGIO RAPIDO: Stringere il montaggio rapido fino a quando la spalla è a filo con il pannello, non stringere troppo o troppo poco.

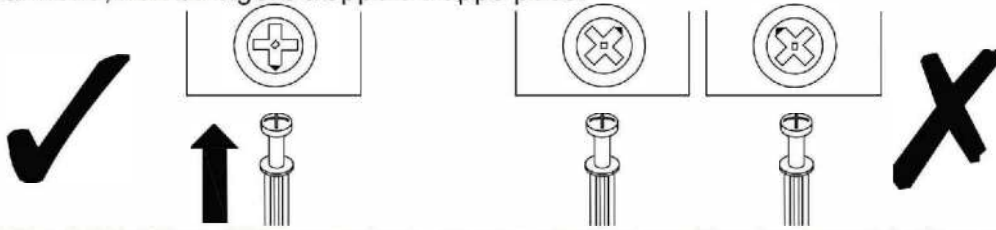

EN_CAM LOCK: When fitting cam lock, ensure starting position is correct before you insert connecting quickfit.

FR_SERRURE BATTEUSE: Avant d'insérer la serrure batteuse, veillez à la bonne orientation avant d'insérer le raccord rapide.

ES_CIERRE DE LA CÁMARA: Cuando instale el cierre de la cámara, asegúrese de que la posición de inicio es correcta antes de que inserte el quickfit conector.

DE_CAM-LOCK: Achten Sie bei der Montage des Cam-Locks auf die richtige Ausgangsposition, bevor Sie den Quickfit einsetzen.

IT_BLOCCAGGIO A CAMMA: Quando si monta il bloccaggio a camma, assicurarsi che la posizione iniziale sia corretta prima di inserire il montaggio rapido di collegamento.

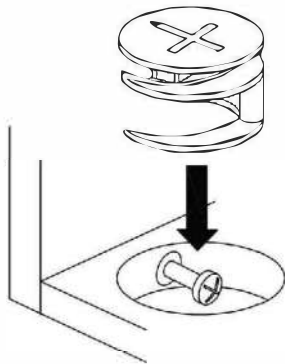

EN_Quickfit head should be in the centre of the cam lock when the two panels are joined.

Cam lock should be inserted before quickfit.

FR_Lorsque les deux panneaux sont assemblés, la tête du raccord rapide doit reposer au centre de la serrure batteuse. Il faut insérer la serrure batteuse avant le raccord rapide.

ES_El cabezal del quickfit debe estar en el centro del cierre de la cámara cuando se unan los dos paneles.

Se debe insertar el cierre de la cámara antes que el quickfit.

DE_Der Quickfit-Kopf sollte sich in der Mitte des Cam-Locks befinden, wenn die beiden Platten zusammengefügt sind.

Der Cam-Lock sollte vor dem Quickfit eingesetzt werden.

IT_La testa del montaggio rapido deve trovarsi al centro del bloccaggio a camma quando i due pannelli sono uniti.

Il Bloccaggio a Camma deve essere inserito prima del montaggio rapido.

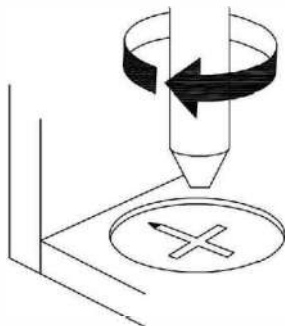

EN_Turn cam lock clockwise to tighten.

FR_Faites tourner la serrure batteuse dans le sens des aiguilles d'une montre pour la resserrer.

ES_Gire el cierre de la cámara en sentido horario para apretarlo.

DE_Drehen Sie den Cam-Lock im Uhrzeigersinn, um ihn festzuziehen.

IT_Ruotare il bloccaggio a camma in senso orario per stringere.

EN It may be necessary to adjust the hinges so that the doors align. Use the instructions below as a guide.

FR Il est parfois nécessaire d'ajuster les charnières pour un meilleur alignement des portes. Servez-vous des instructions ci-dessous comme guide.

ES Puede que sea necesario ajustar los quicios de forma que se alineen las puertas. Use las instrucciones que aparecen debajo como guía.

DE Möglicherweise müssen Sie die Scharniere so einstellen, dass die Türen ausgerichtet sind. Verwenden Sie die nachstehenden Anweisungen als Leitfaden.

IT Potrebbe essere necessario regolare le cerniere in modo che le porte siano allineate. Per fare ciò attenersi alle istruzioni sottostanti.

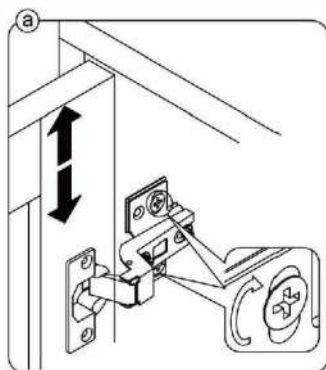

EN To adjust the door vertically loosen the screw as shown and move up and down as needed.

FR Si vous souhaitez régler la porte **verticalement**, desserrez la vis comme indiqué et déplacez la porte de haut en bas selon les besoins.

ES Para ajustar la puerta **verticalmente** afloje el tornillo tal y como se muestra y muévelo hacia arriba o hacia abajo según sea necesario.

DE Um die Tür **vertikal** auszurichten, lösen Sie die Schraube wie abgebildet und bewegen Sie sie nach Bedarf nach oben oder nach unten.

IT Per allineare la porta **verticalmente** allentare la vite come mostrato e spostarla in alto o in basso secondo necessità.

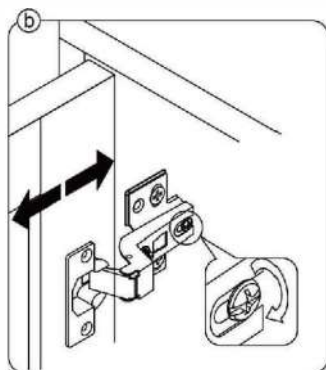

EN To adjust the gap from the door to the main frame turn the screw clockwise or anti-clockwise as needed.

FR Si vous souhaitez ajuster l'**écart** entre la porte et le cadre principal, tournez la vis dans le sens des aiguilles d'une montre ou dans le sens inverse, si nécessaire.

ES Para ajustar el **espacio** desde la puerta al marco principal, gire el tornillo en sentido horario o antihorario, según se necesite.

DE Um den **Abstand** von der Tür zum Hauptrahmen auszurichten, drehen Sie die Schraube je nach Bedarf im oder gegen den Uhrzeigersinn.

IT Per regolare lo **spazio** tra la porta e il telaio principale, avvitare o svitare la vite secondo necessità.

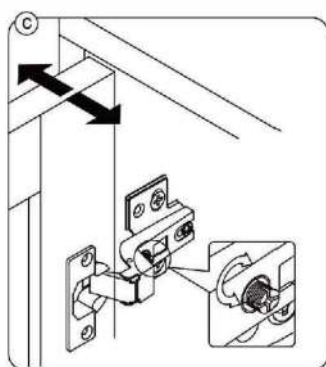

EN To adjust the door laterally adjust the screw as shown by turning clockwise or anti-clockwise.

FR Si vous souhaitez ajuster la porte **latéralement**, ajustez la vis comme indiqué en tournant dans le sens des aiguilles d'une montre ou dans le sens inverse des aiguilles d'une montre.

ES Para ajustar la puerta **lateralmente** ajuste el tornillo tal y como se muestra girándolo en sentido horario y antihorario.

DE Um die Tür **seitlich** auszurichten, stellen Sie bitte die Schraube wie abgebildet durch Drehen im oder gegen den Uhrzeigersinn ein.

IT Per allineare la porta **lateralmente** regolare la vite come mostrato, avvitandola o svitandola.

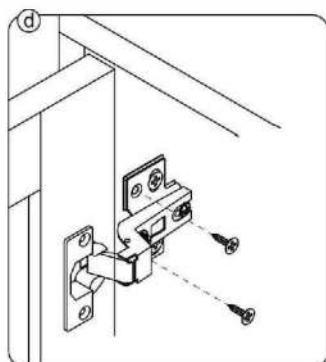

EN Please fix other screws

FR Merci de serrer les autres vis.

ES Fije los demás tornillos

DE Befestigen Sie bitte die anderen Schrauben

IT Fissare le altre viti

Shenzhen ZKT Technology Co., Ltd.
 1/F, No. 101, Building B, No. 6, Tangwei Community Industrial Avenue,
 Fuhai Street, Bao'an District, Shenzhen, China



Certificate of Compliance

Certificate Number: ZKT-25070715599C-R1

Certificate's Holder : Natulighting(shenzhen) TechnologyCo.,LTD
 2nd Floor, Building A9, Xinghua Xiong Industrial Park,
 Baihuadong, Guangming District, Shenzhen

Manufacturer : Natulighting(shenzhen) TechnologyCo.,LTD
 2nd Floor, Building A9, Xinghua Xiong Industrial Park,
 Baihuadong, Guangming District, Shenzhen

Trade Mark : N/A

Product : Colorful Light strip

Model(s) : 5V-60-RGB
 5V-30-RGB

REQUIREMENT	STANDARD	Report No.
Art.3.1(a) Safety	EN IEC 62368-1:2024+A11:2024	ZKT-25070715600S-R1
Art.3.1(a) Health	EN IEC 62311:2020 EN 50665:2017	ZKT-25070715599E-1-R1
Art.3.1(b) EMC	ETSI EN 301 489-1 V2.2.3 (2019-11) ETSI EN 301 489-17 V3.3.1 (2024-09) ETSI EN 301 489-3 V2.3.2 (2023-01)	ZKT-25070715599E-2-R1
Art.3.2 Radio	ETSI EN 300 328 V2.2.2 (2019-07)	ZKT-25070715599E-3-R1
	ETSI EN 300 440 V2.2.1 (2018-07)	ZKT-25070715599E-4-R1

This Attestation of Compliance is issued on a voluntary basis for electrical equipment below the voltage limits of Radio Equipment Directive (RED) 2014/53/EU. The essential requirements are fulfilled accordingly based on the technical specifications applicable at the time of issuance.



This Certificate of Conformity is based on single evaluation of the submitted sample(s) of the above mentioned product. It does not imply an assessment of the whole product and relevant Directives to be observed.

Shenzhen ZKT Technology Co., Ltd.

1/F, No. 101, Building B, No. 6, Tangwei Community Industrial Avenue,
Fuhai Street, Bao'an District, Shenzhen, China



Certificate of Compliance

Certificate Number: ZKT-25070715601C-R1

Certificate's Holder : Natulighting(shenzhen) TechnologyCo.,LTD
2nd Floor, Building A9, Xinghua Xiong Industrial Park,
Baihuadong, Guangming District, Shenzhen, China

Manufacturer : Natulighting(shenzhen) TechnologyCo.,LTD
2nd Floor, Building A9, Xinghua Xiong Industrial Park,
Baihuadong, Guangming District, Shenzhen, China

Trade Mark : N/A

Product : Colorful Light strip

Model(s) : 5V-60-RGB
5V-30-RGB

Test Method : IEC 62321-3-1:2013, IEC 62321-4:2013+A1:2017, IEC
62321-5:2013, IEC 62321-6:2015, IEC 62321-7-1:2015, IEC
62321-7-2:2017, IEC 62321-8:2017

The following products have been tested by us and found in conformity with the (RoHS) Directive 2011/65/EU Annex II amending Annex (EU)2015/863 and amending Annex (EU)2017/2102. It is possible to use CE Marking to demonstrate the conformity with this Directive.It is only valid in connection with the test report number: ZKT-25070715601R-R1.

RoHS

Shenzhen ZKT Technology Co., Ltd.
Approved
Manager
Sep. 19, 2025

This Certificate of Conformity is based on single evaluation of the submitted sample(s) of the above mentioned product. It does not imply an assessment of the whole product and relevant Directives to be observed.

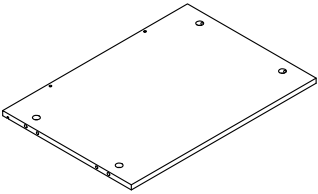
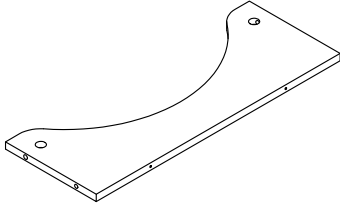
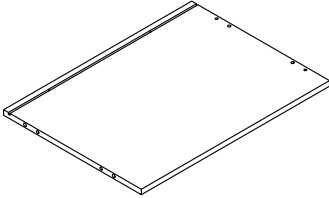
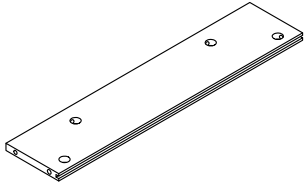
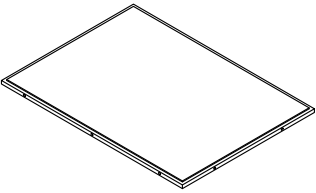
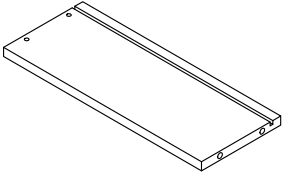
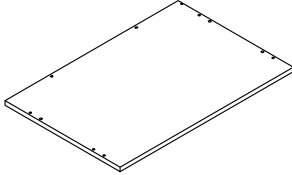
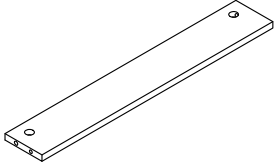
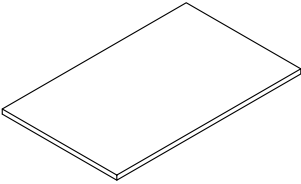
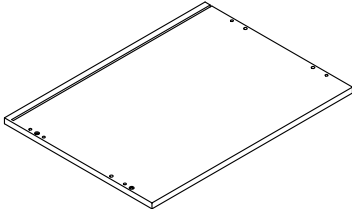
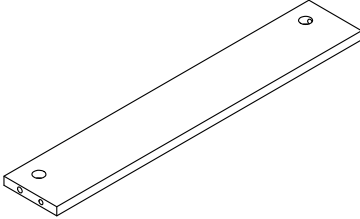
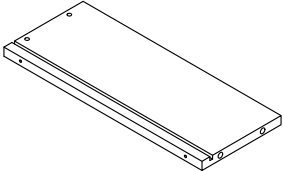
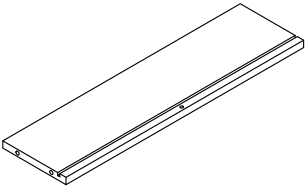
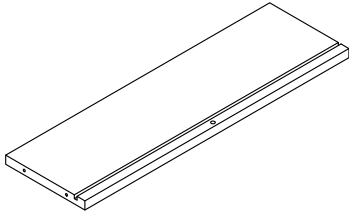
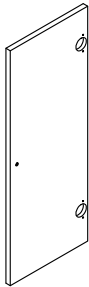
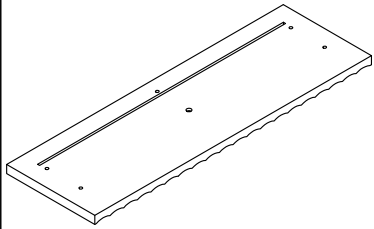
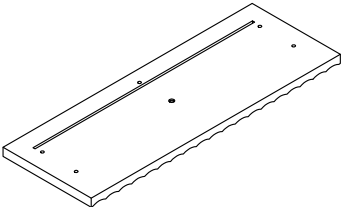
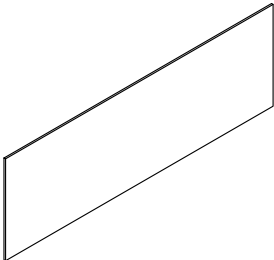
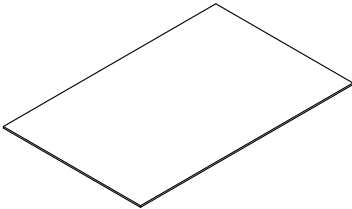
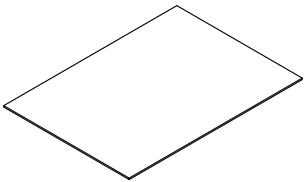

PACKING DETAILS:TOTAL 2 BOXES

N621P451588 - Box:1/2

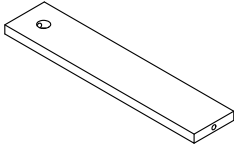
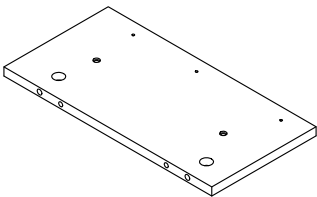

			
⑤ x1	⑥ x1	⑦ x1	⑧ x1
			
⑨ x1	⑩ x2	⑪ x1	⑭ x1
			
⑮ x3	⑰ x1	⑳ x1	㉒ x2
			
㉓ x1	㉔ x1	㉕ x2	㉖ x1
			
㉗ x1	㉘ x1	㉛ x1	㉜ x1

PACKING DETAILS:TOTAL 2 BOXES

N621P451588 - Box:1/2



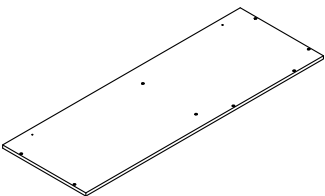
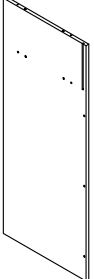
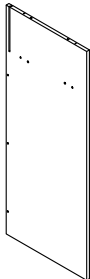
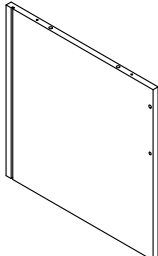
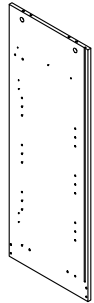
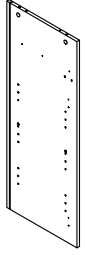
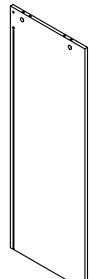
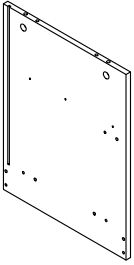
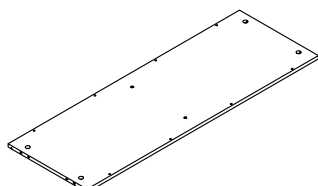
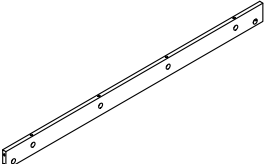
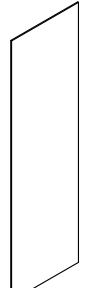



			
③⑤ x2	③⑥ x1	S x1	Y x1

N621P451589 - Box:2/2

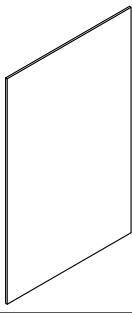





			
① x1	② x1	③ x1	④ x1
			
⑫ x1	⑬ x1	⑯ x1	⑱ x1
			
⑲ x1	⑳ x2	⑳ x2	⑳ x1

PACKING DETAILS:TOTAL 2 BOXES

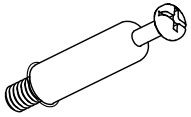
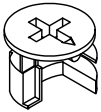
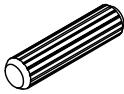
N621P451589 - Box:2/2

			 <p>L=350mm</p>
<p>③① x2</p>	<p>③② x2</p>	<p>③⑦ x1</p>	<p>T X1</p>
 <p>L=879mm</p>	 <p>L=363mm</p>	 <p>L=846mm</p>	
<p>U X1</p>	<p>V X1</p>	<p>W X1</p>	<p>Hardware X 1</p>

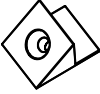
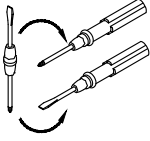
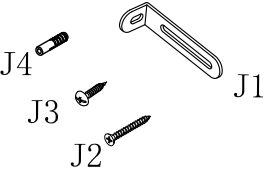
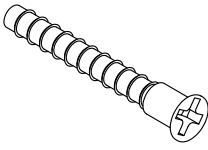
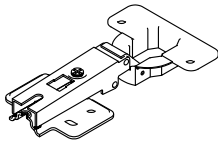
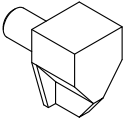
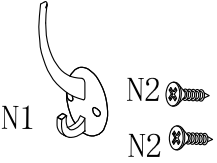
Hardware-Liste:N621P451589

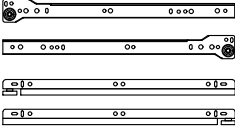
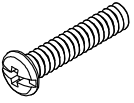
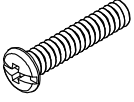
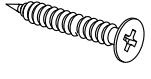
 Ø6 X 35mm	 Ø15 X 9.5mm	 Ø6 X 30mm	 M3.5 X 35mm
A x62+1	B x62+1	C x50+1	D x10
 M3.5 x 12 mm	 M3 x 16 mm		
E x44+1	F x56+2	G x56+2	H x1
	 Ø5 X38mm	 D=35	 Ø5 X 9mm
J x2	K x20+1	L x4	M x12
			 M4 X 15mm
N x 3	O x4	P x2	Q x2
 M4 X 12mm	 M3.5 X 20mm		
R x2	X x2		

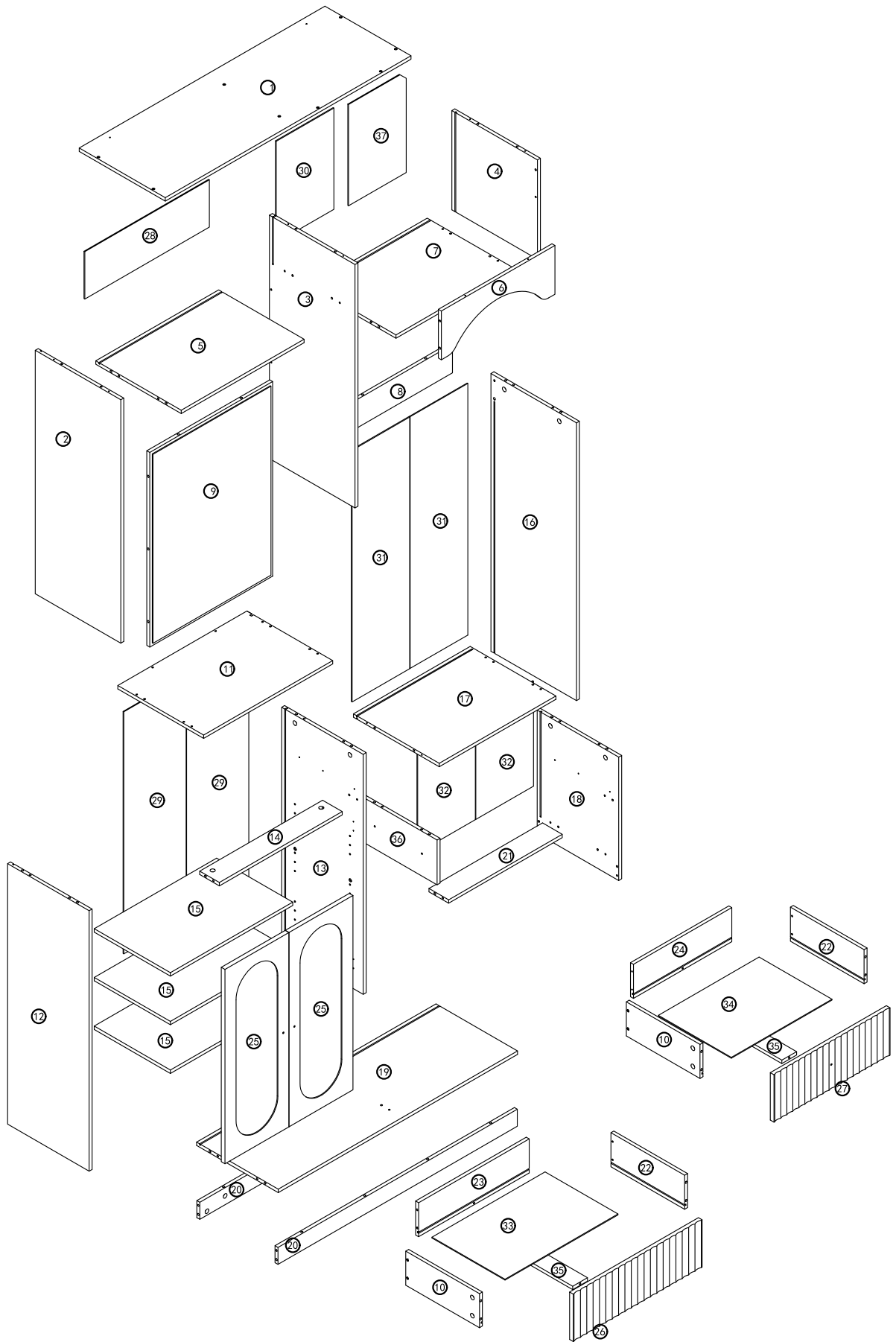

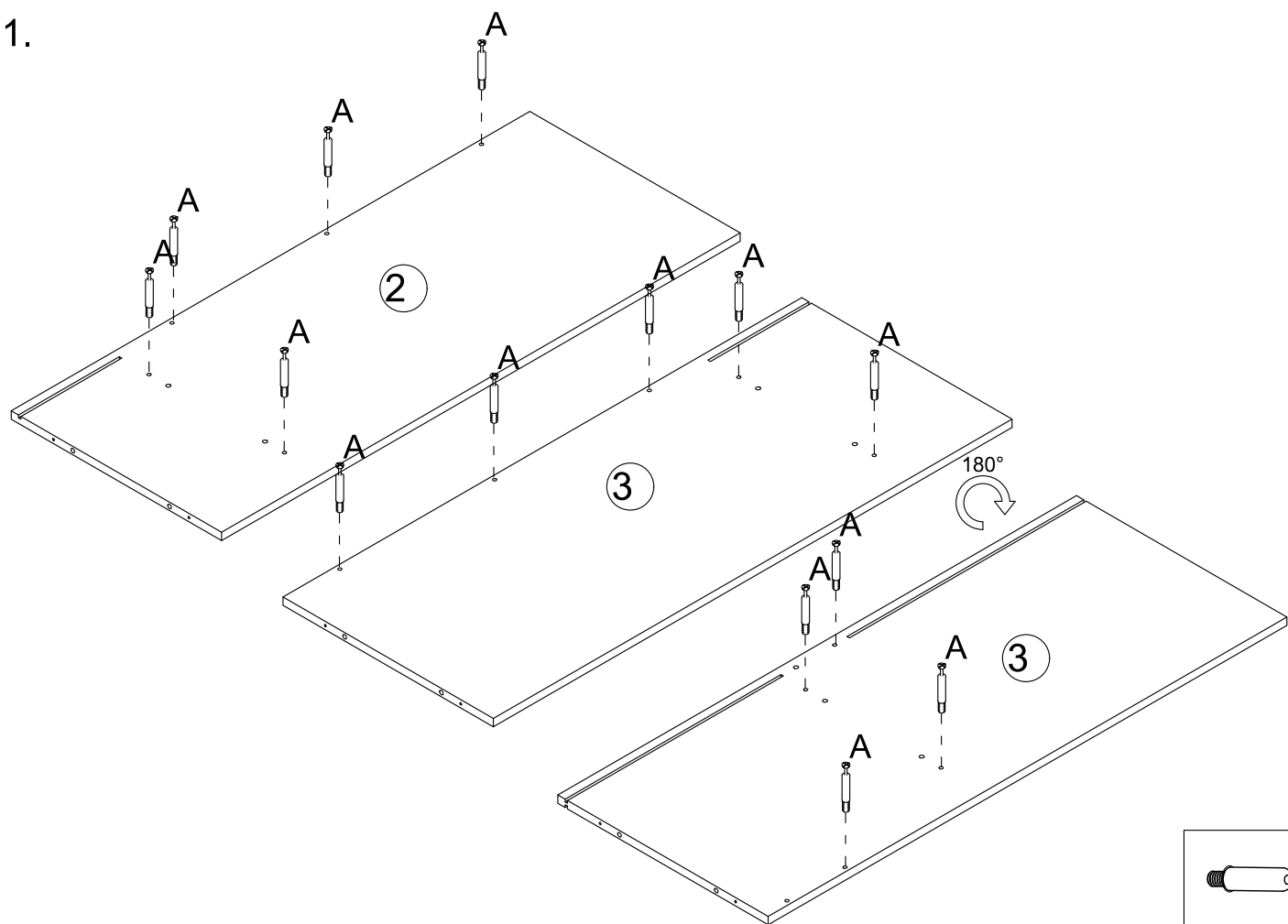

1.

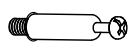

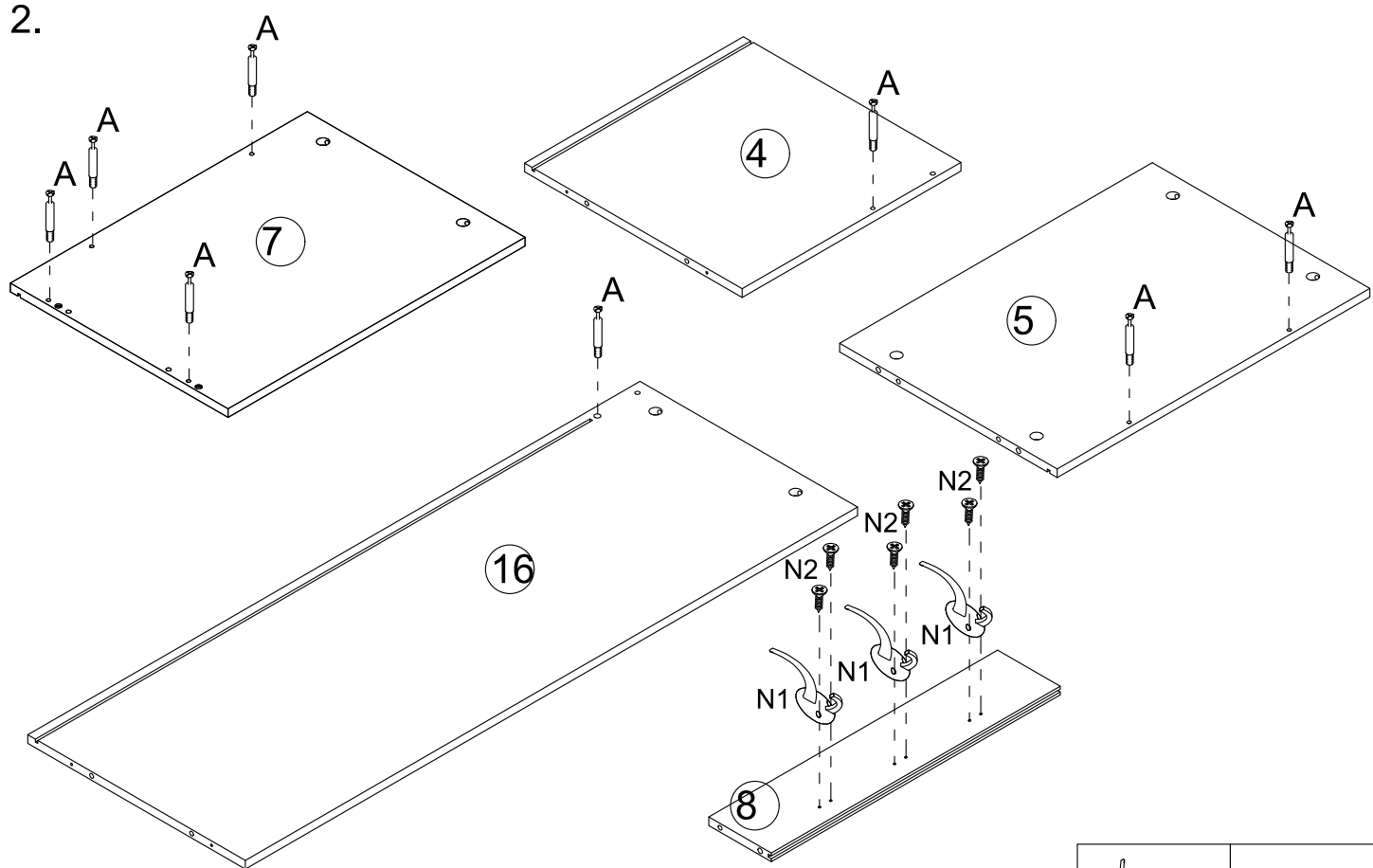

A X 14

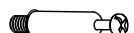

2.

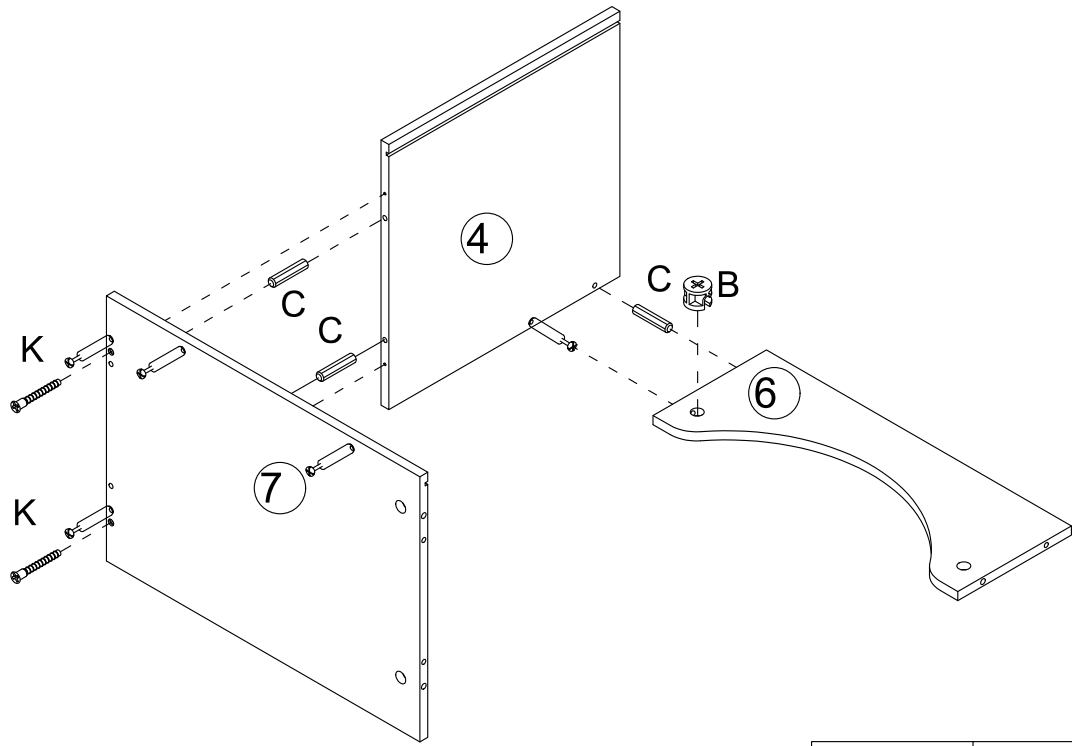

		
N1	N2	A X 8
N X 3		

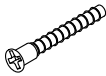

3.



		
K X 2	C X 3	B X 1

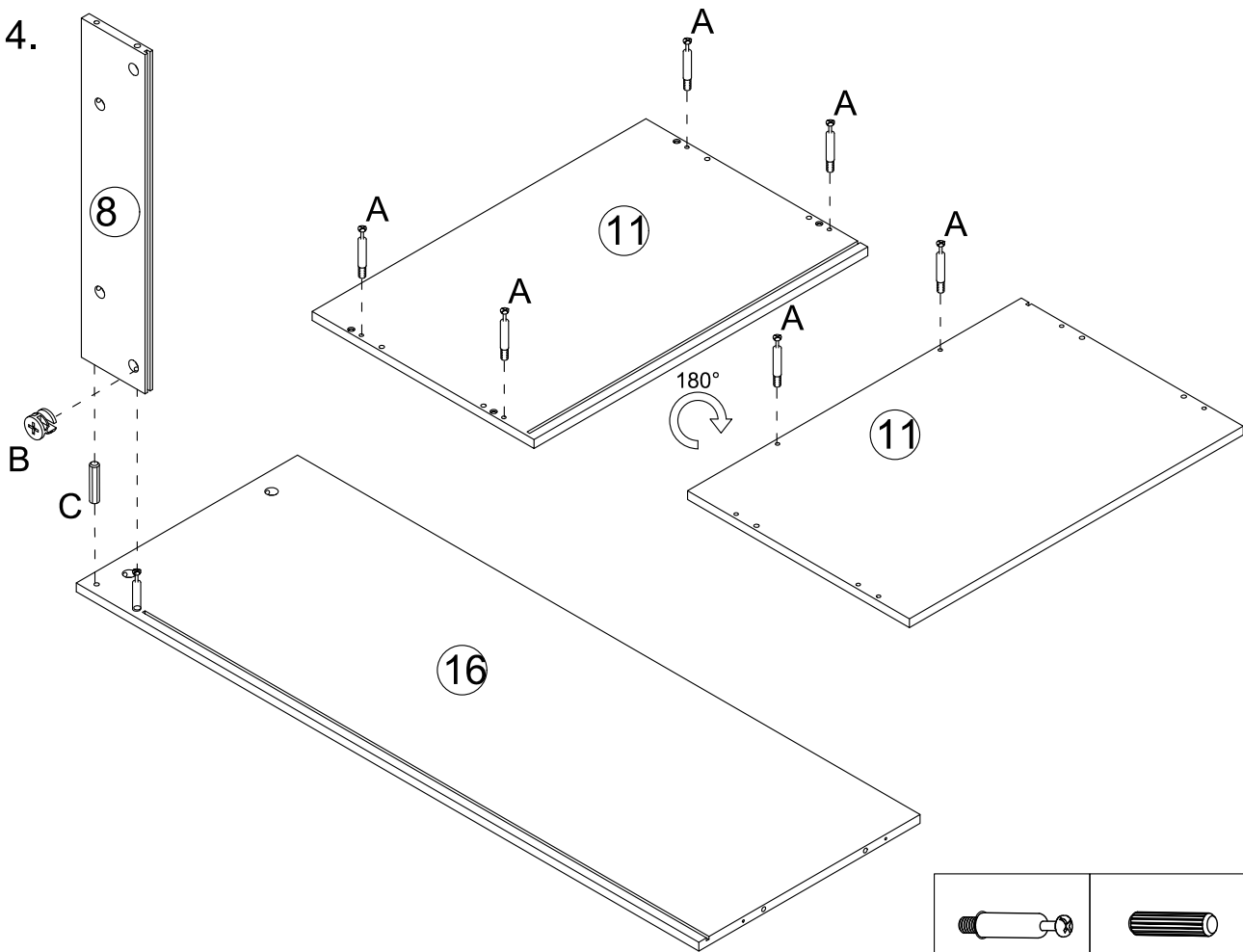

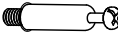
4.



		
A X 6	C X 1	B X 1

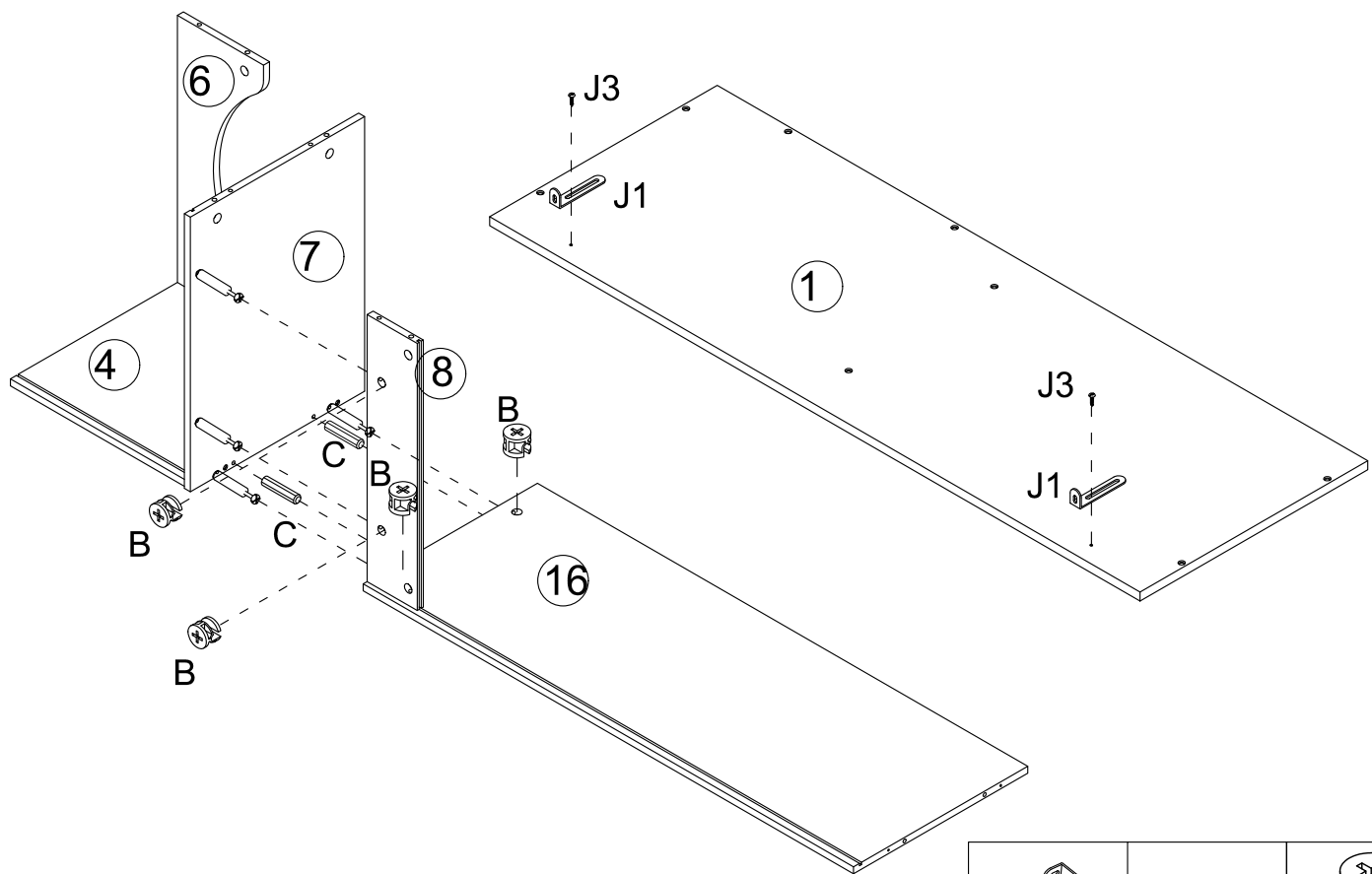

5.



		
J-J1, J3 X2	C X 2	B X 4

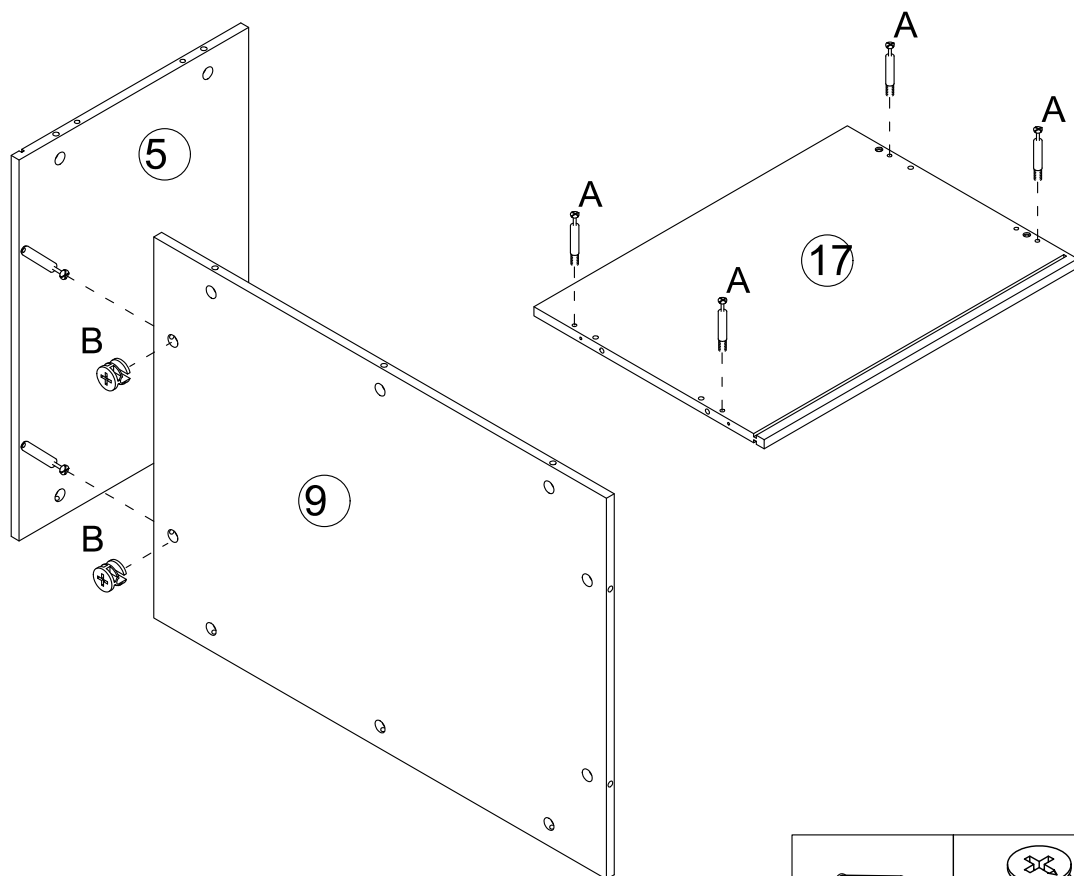

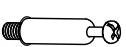
6.



	
A X 4	B X 2

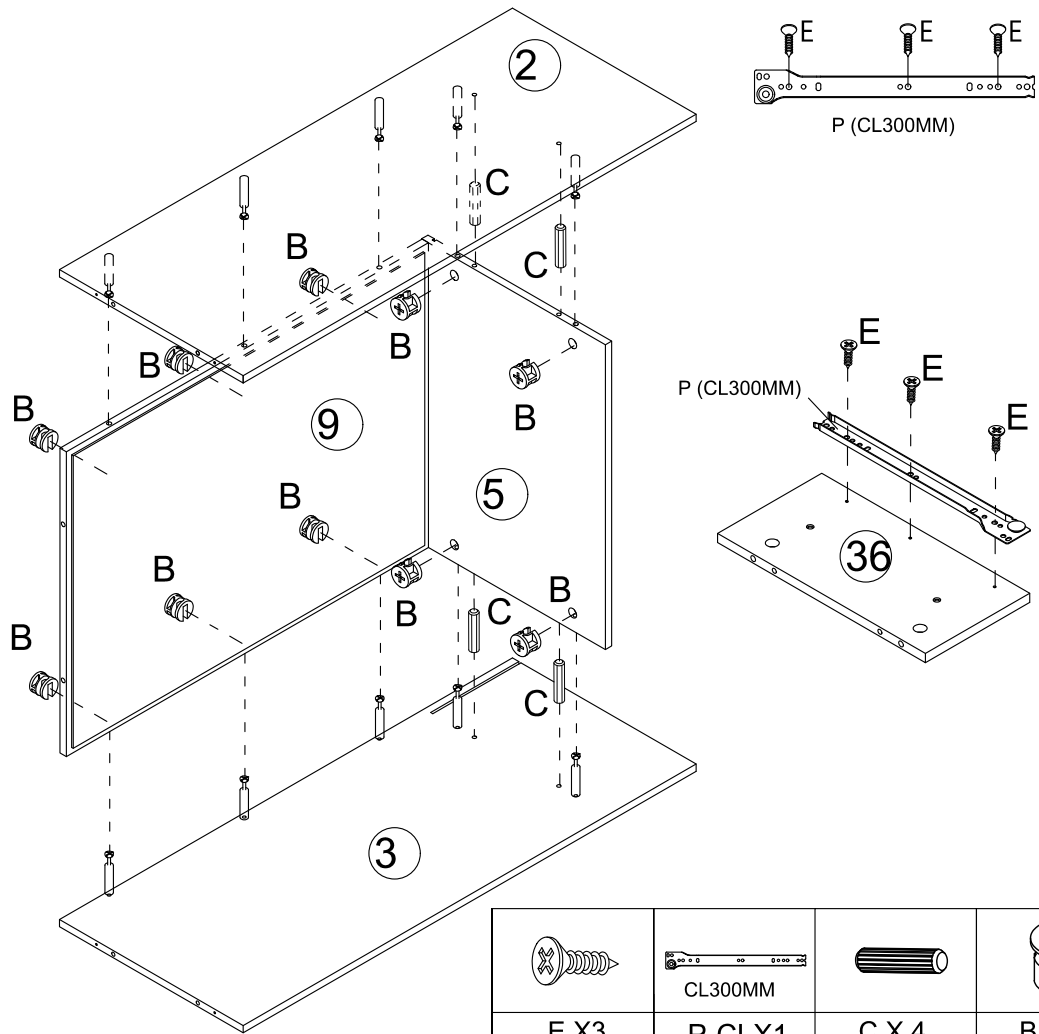

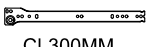
7.

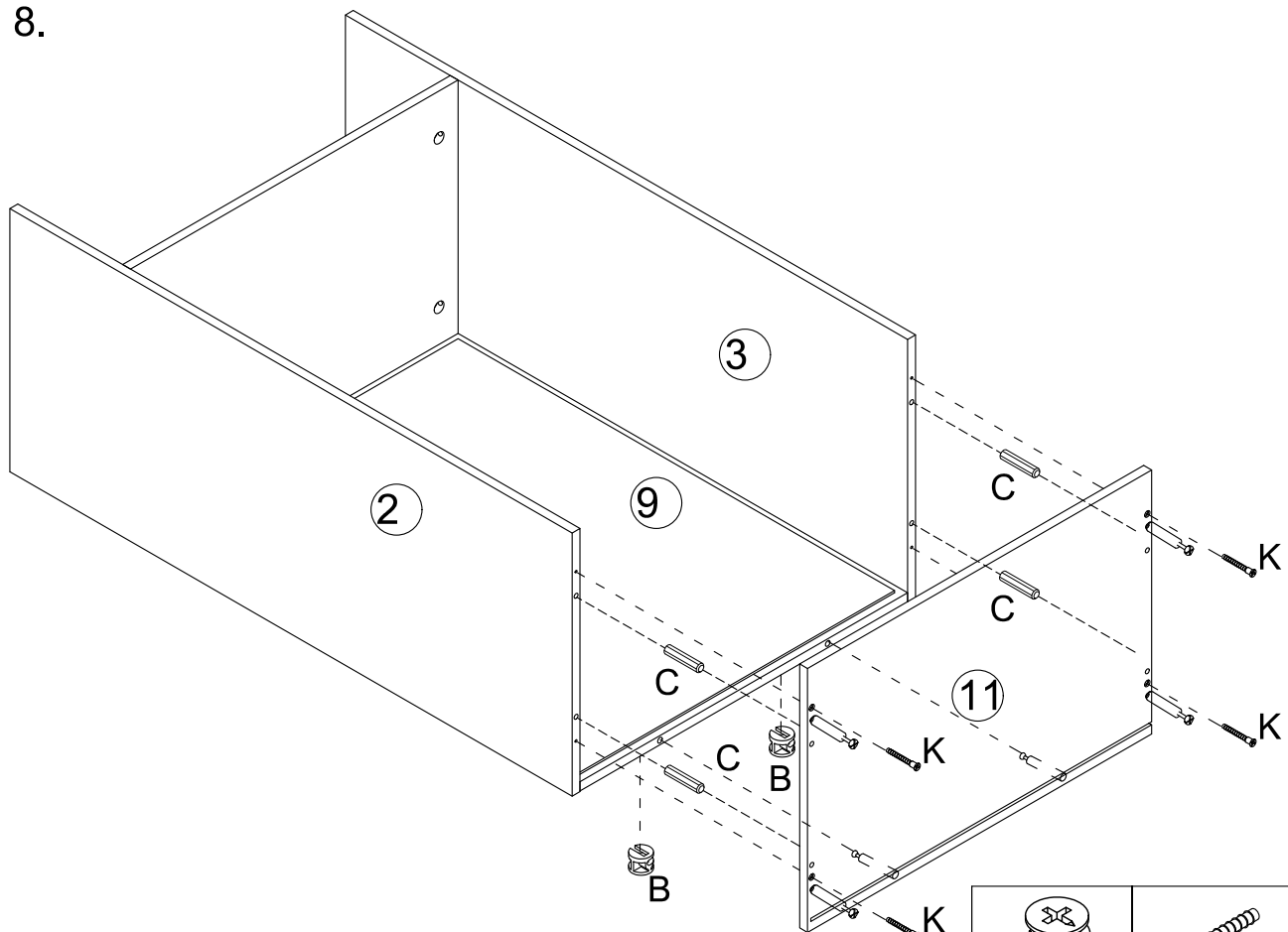

			
E X 3	P-CLX1	C X 4	B X 10

8.

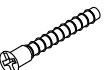

		
B X 2	K X 4	C X 4

9.

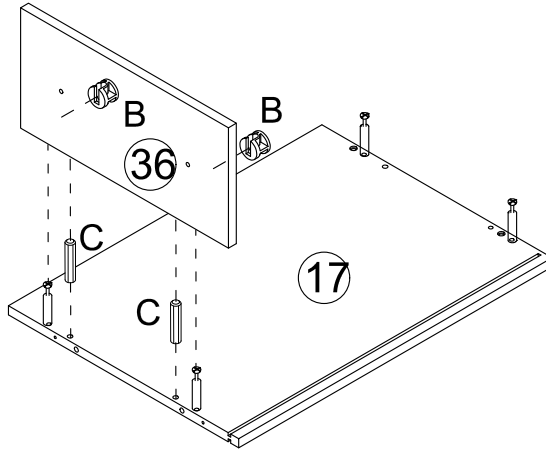
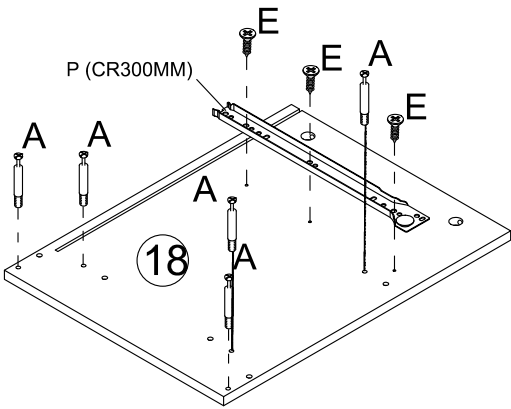
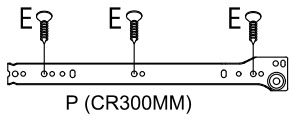

C X 2	B X 2	E X 3	A X 5	P-CR300MM

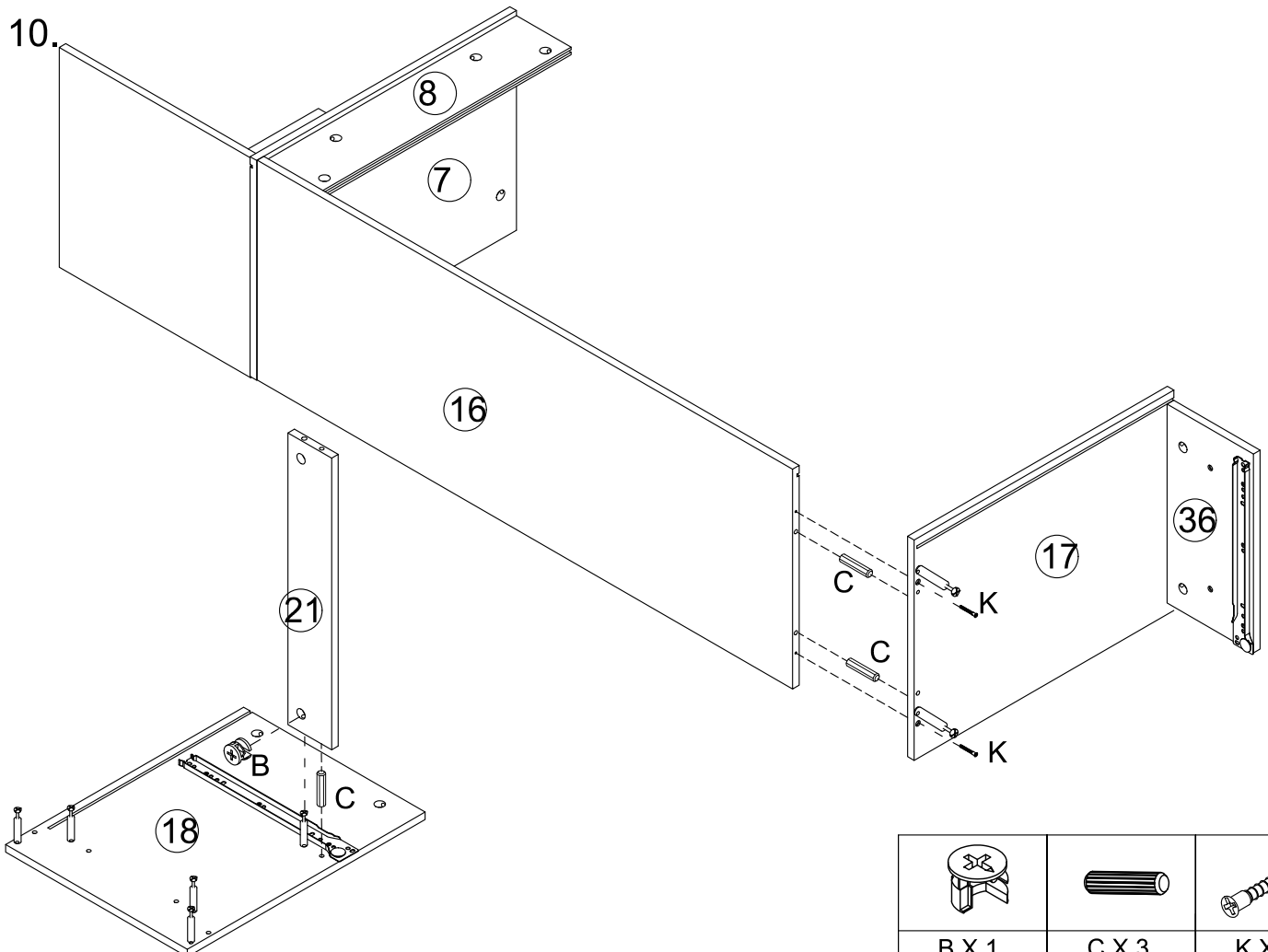

10.



B X 1	C X 3	K X 2

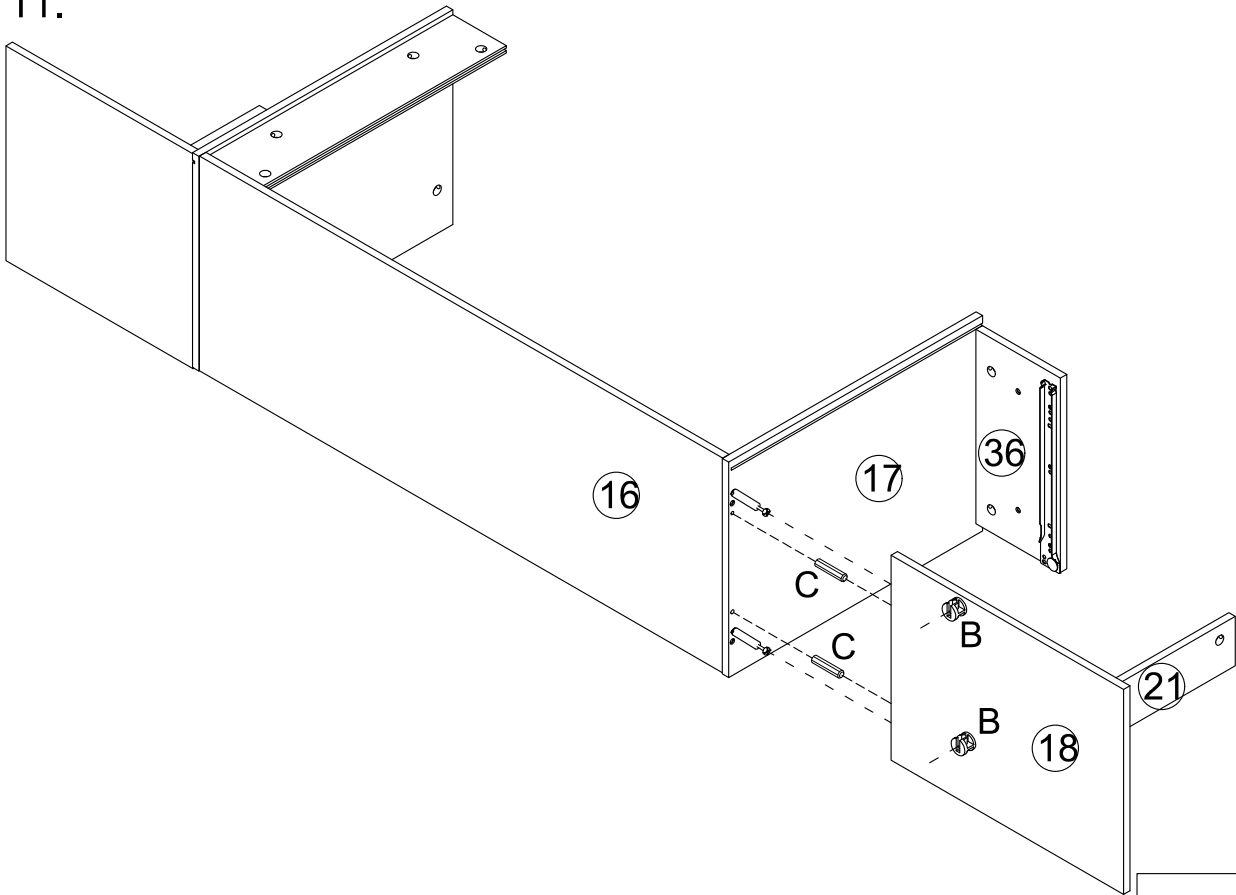

11.

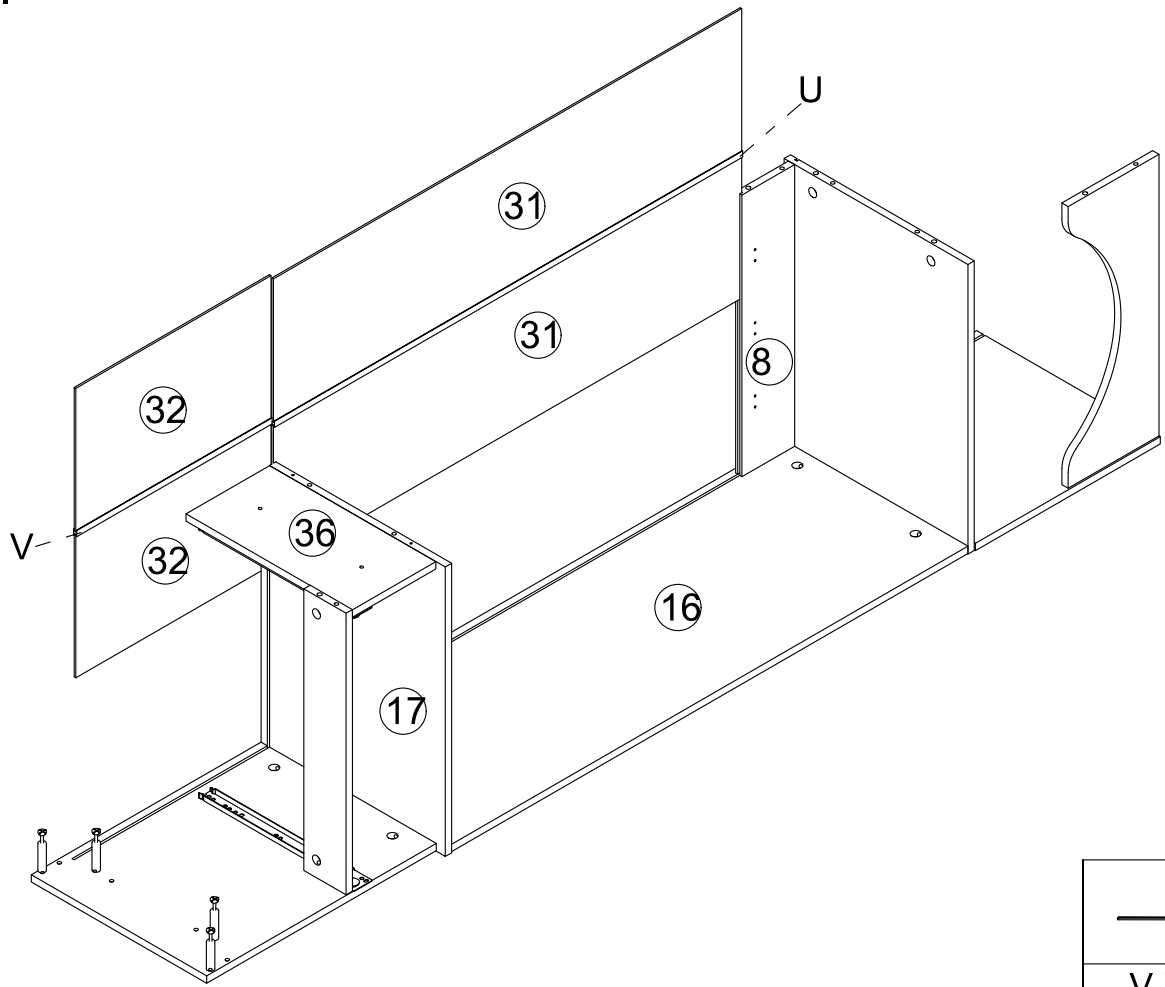

	
C X 2	B X 2

12.



	
V X 1	U X 1

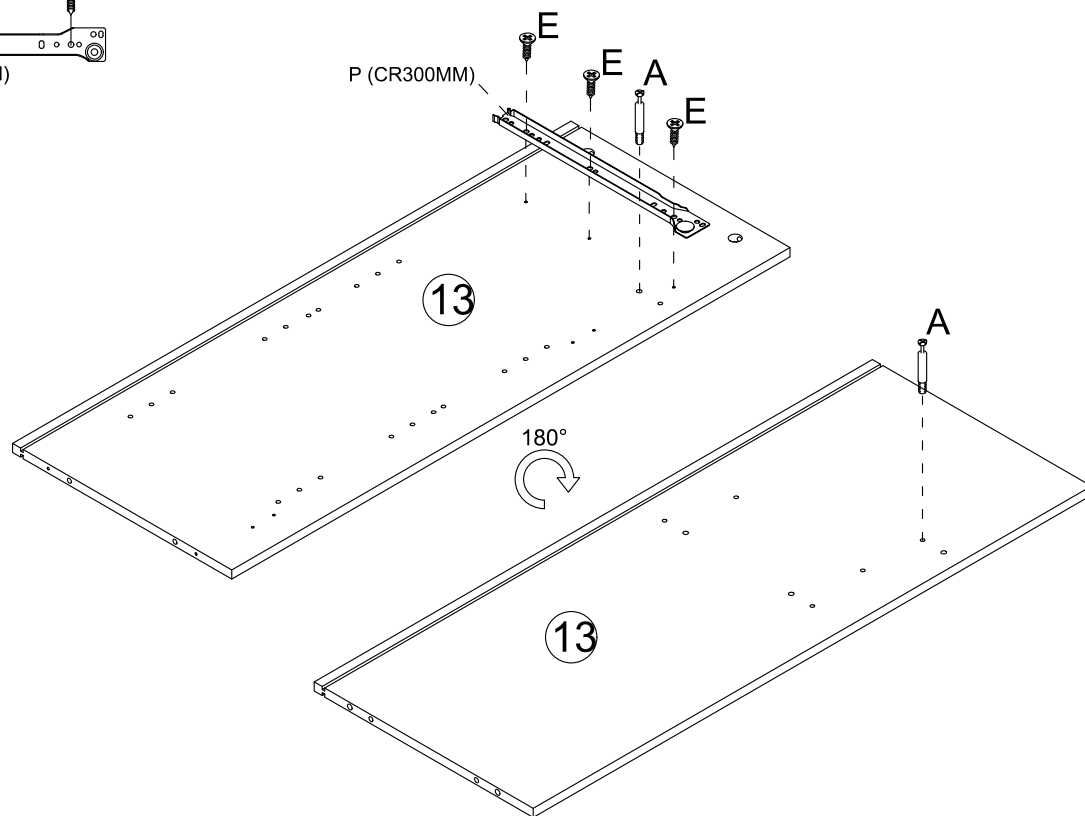
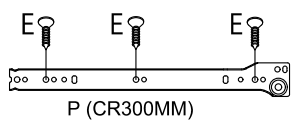

13.

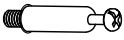
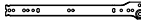

		
E X3	A X2	CR300MM P-CRX1

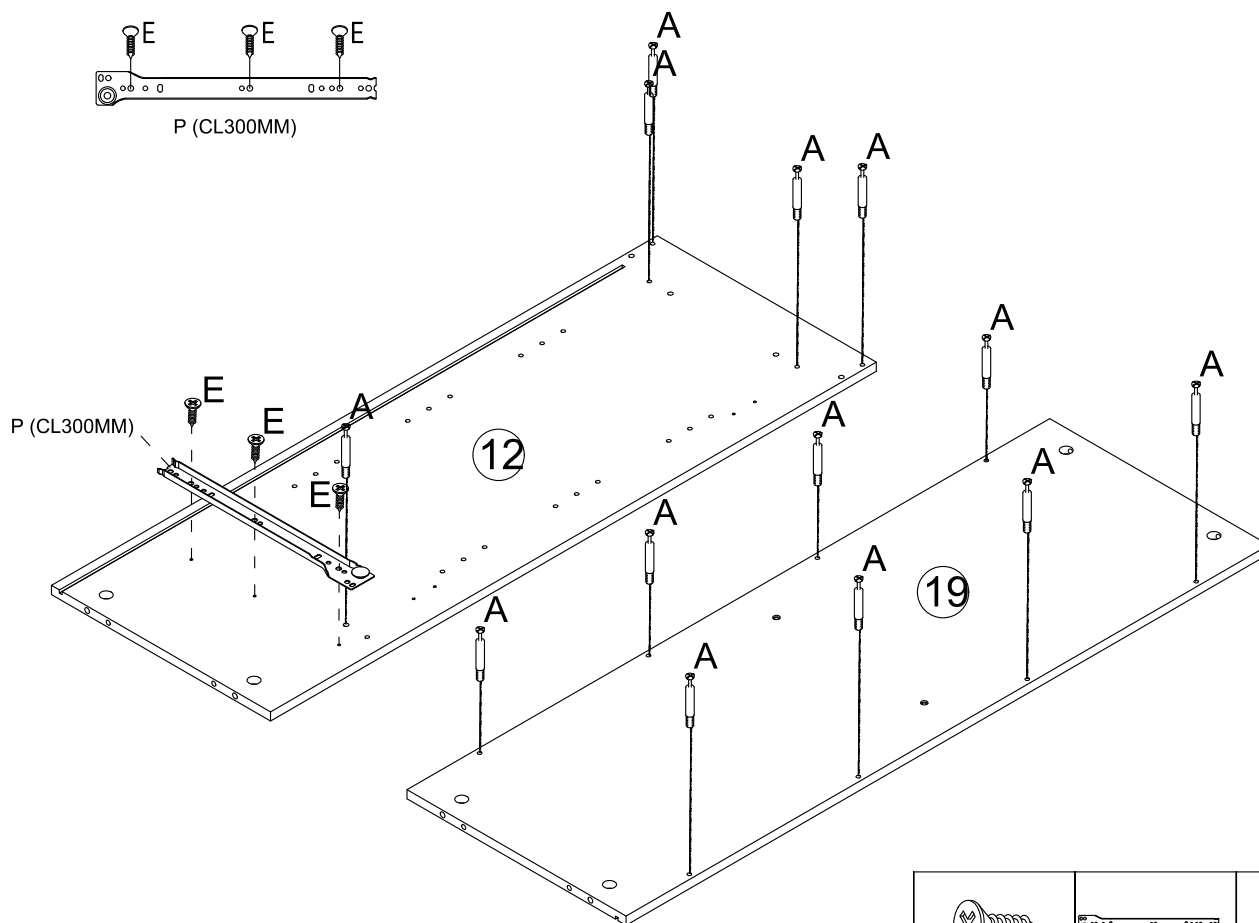
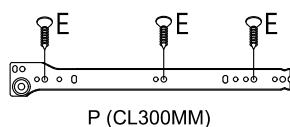
14.

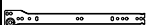

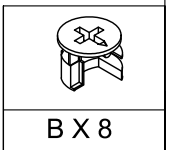
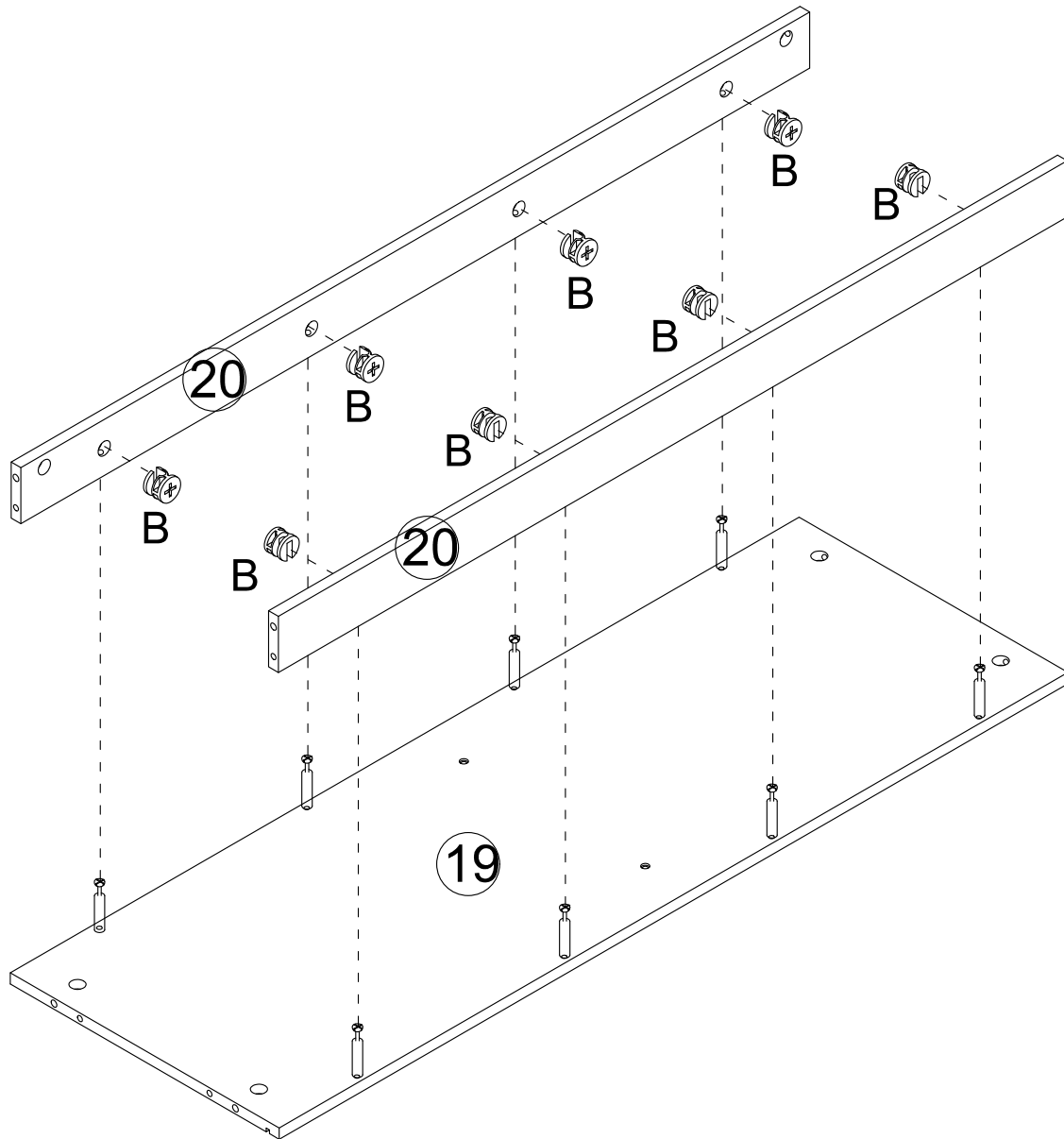

		
E X3	CL300MM P-CL X1	A X13

15.



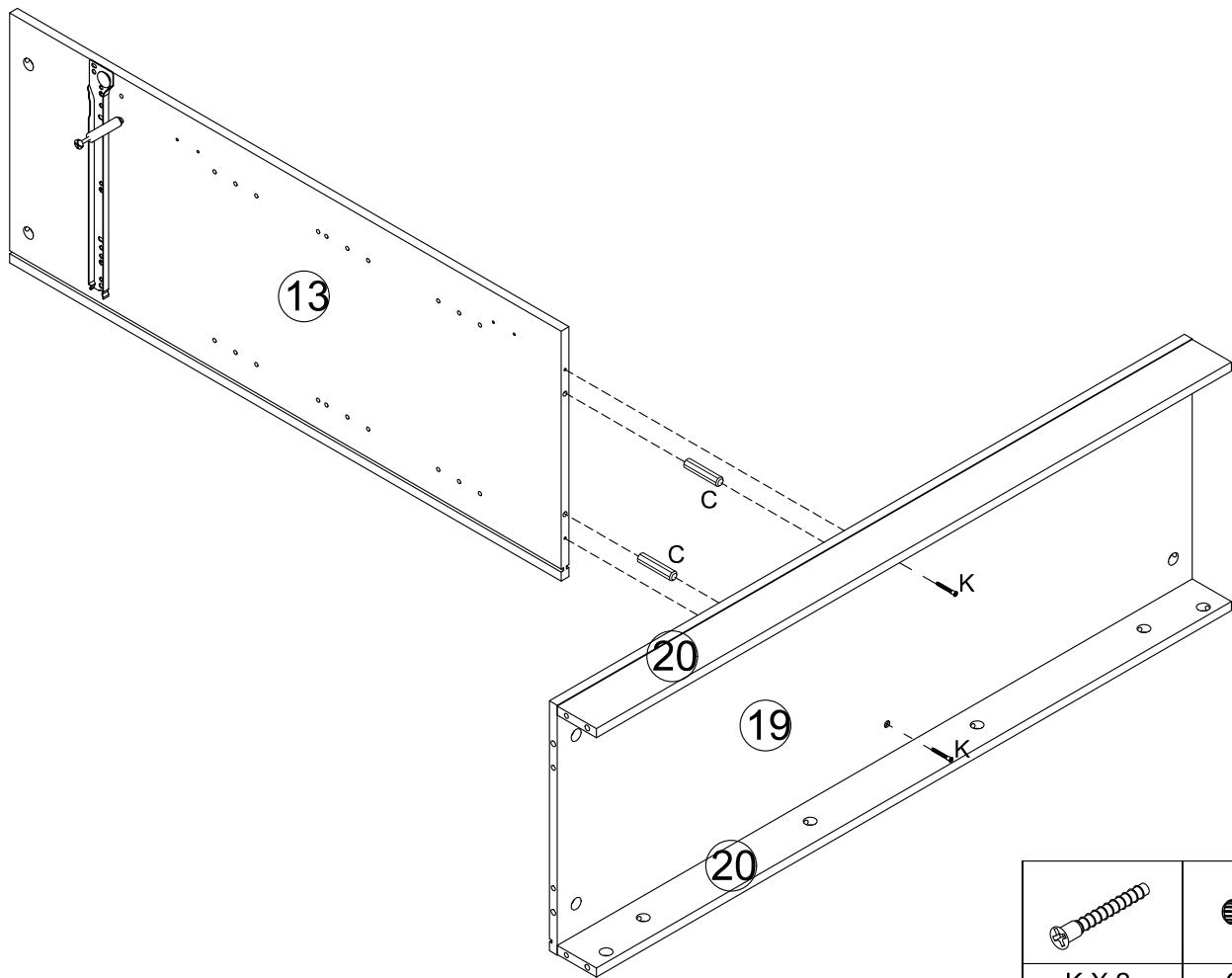

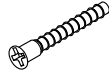
16.



	
K X 2	C X 2

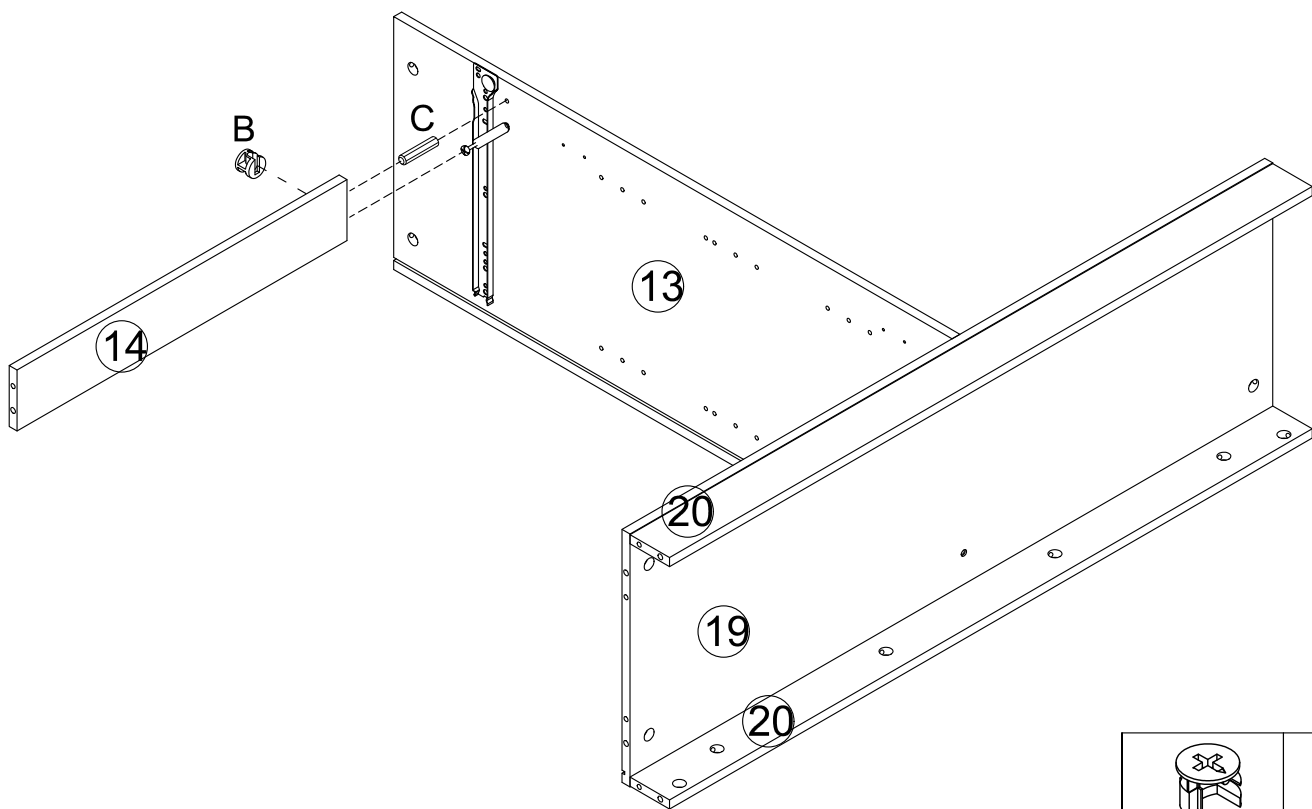

17.

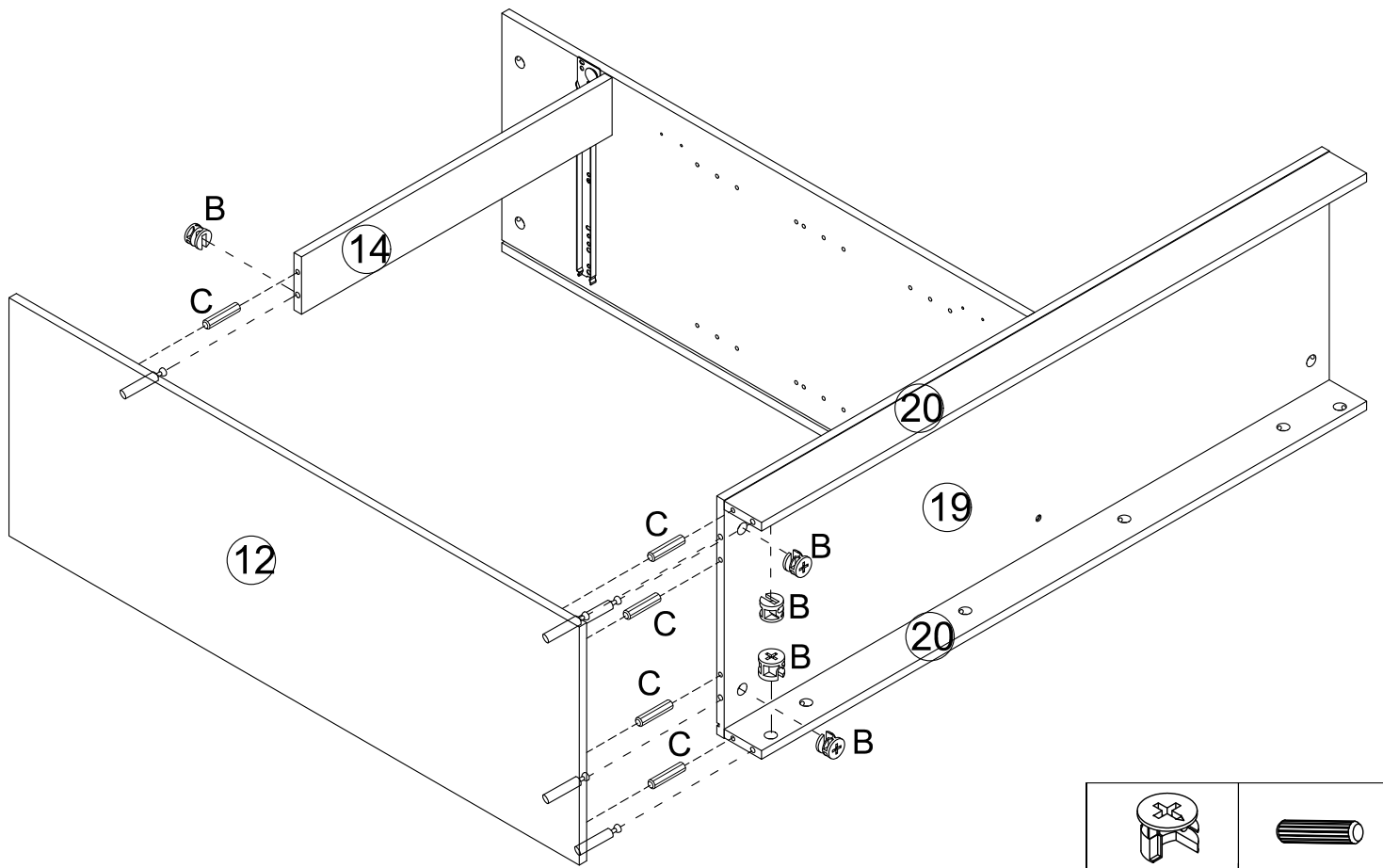

	
B X 1	C X 1

18.



	
B X 5	C X 5

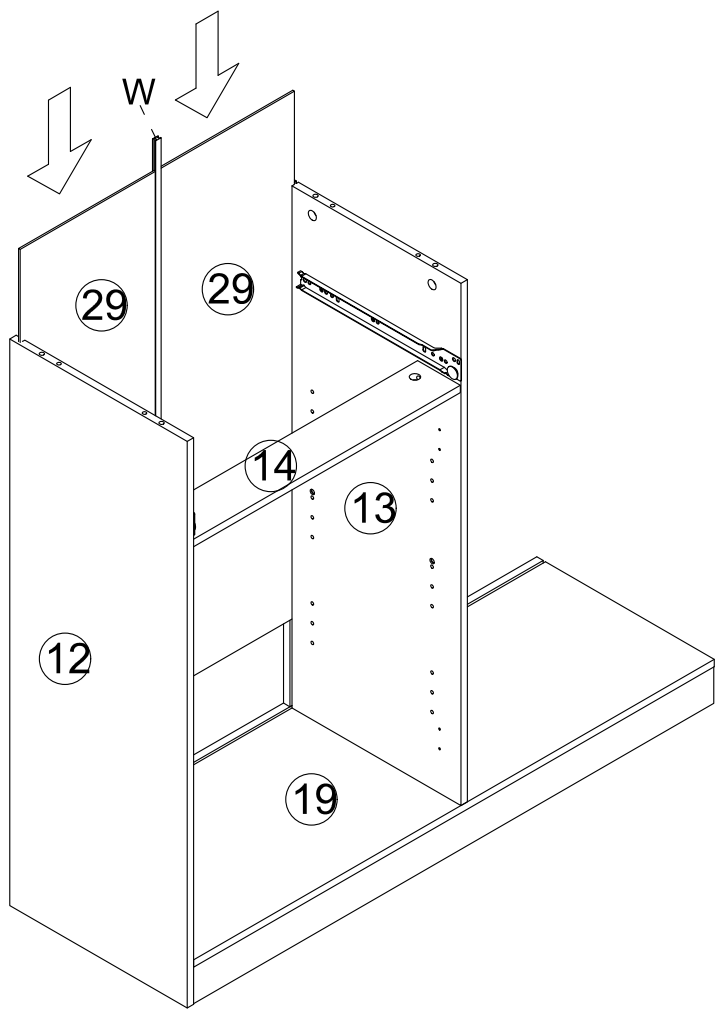

19.



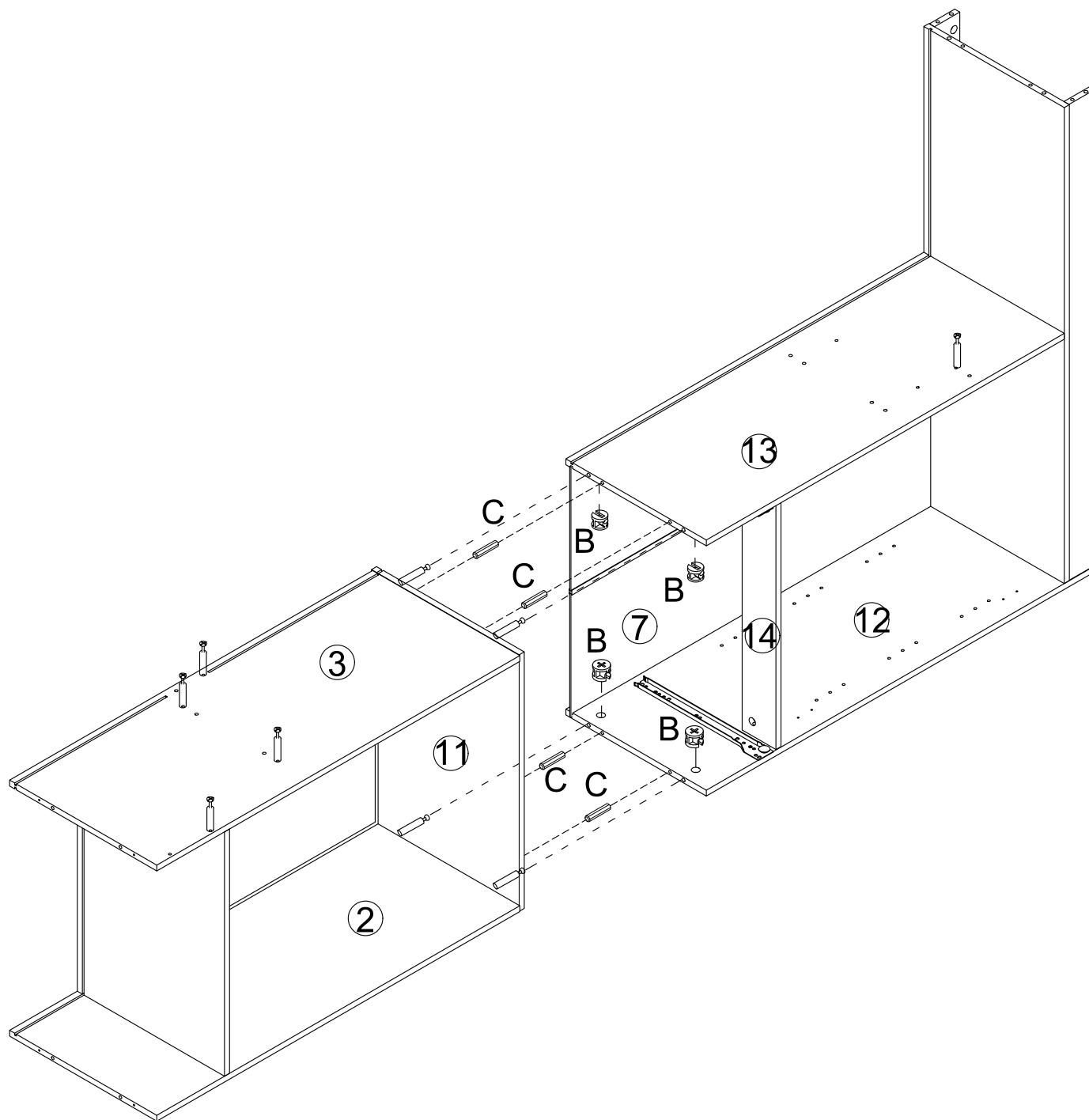

W X 1

20.



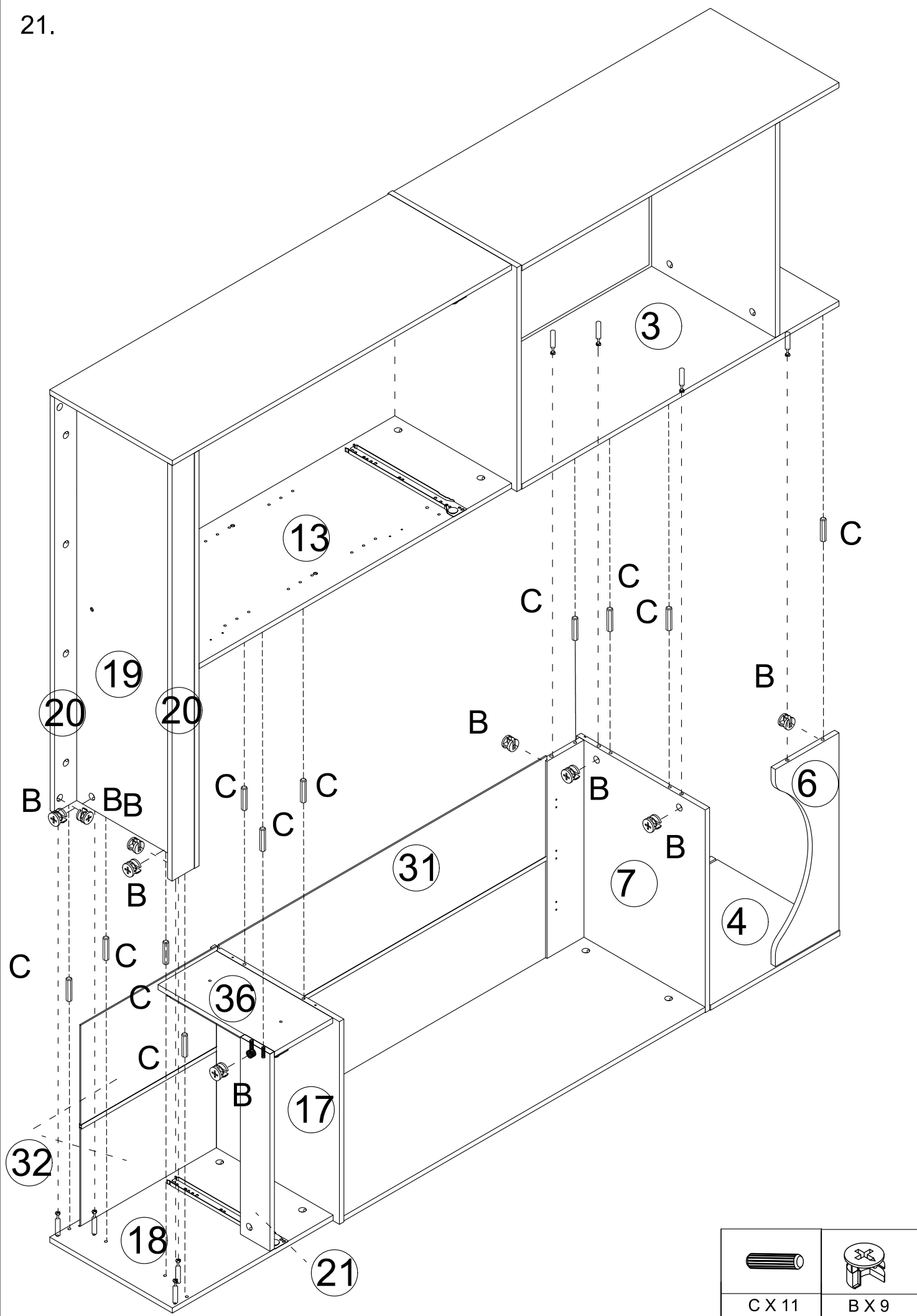

	
C X 4	B X 4

21.



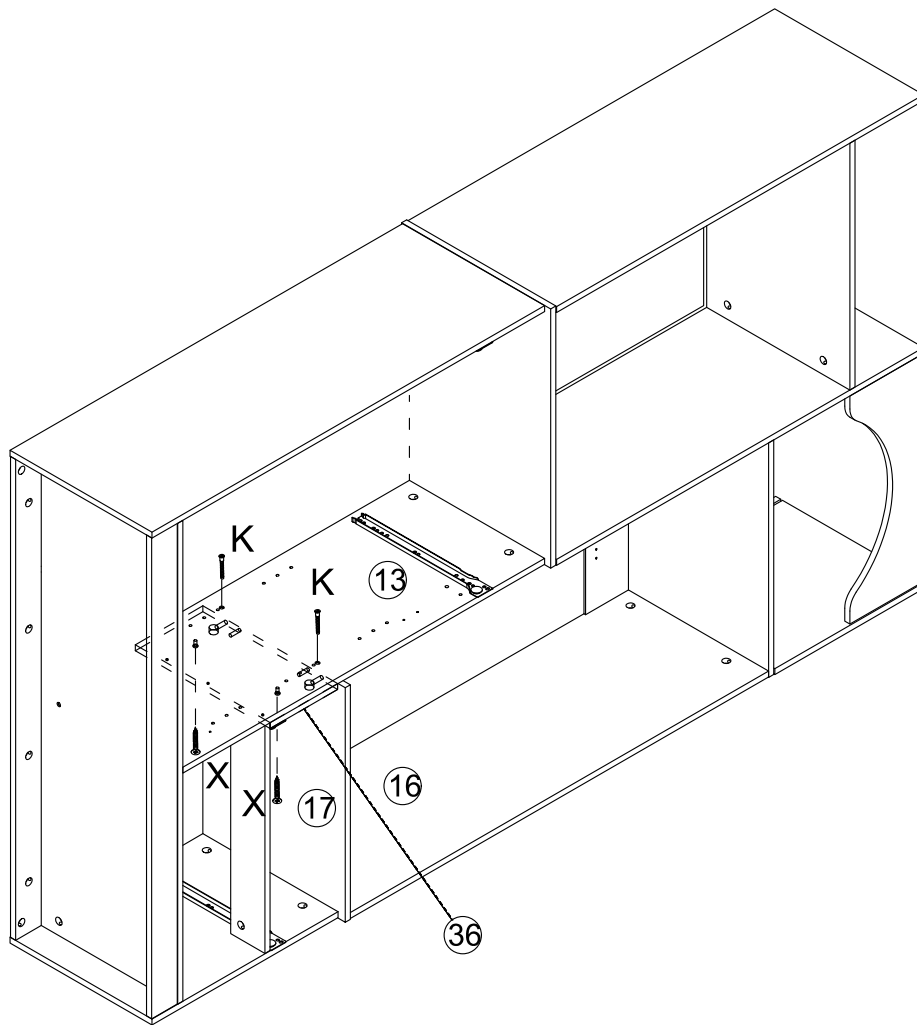

22.

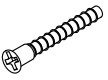

	
X x 2	K x 2

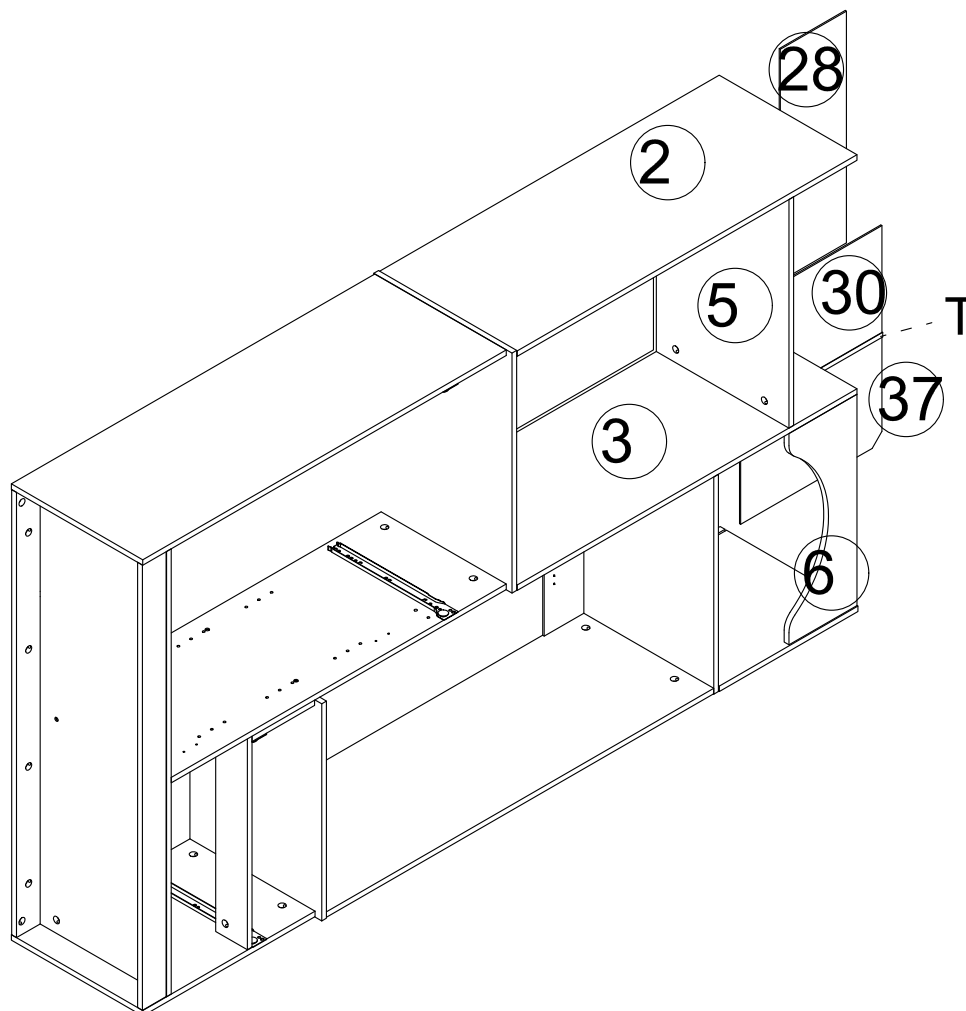

23.



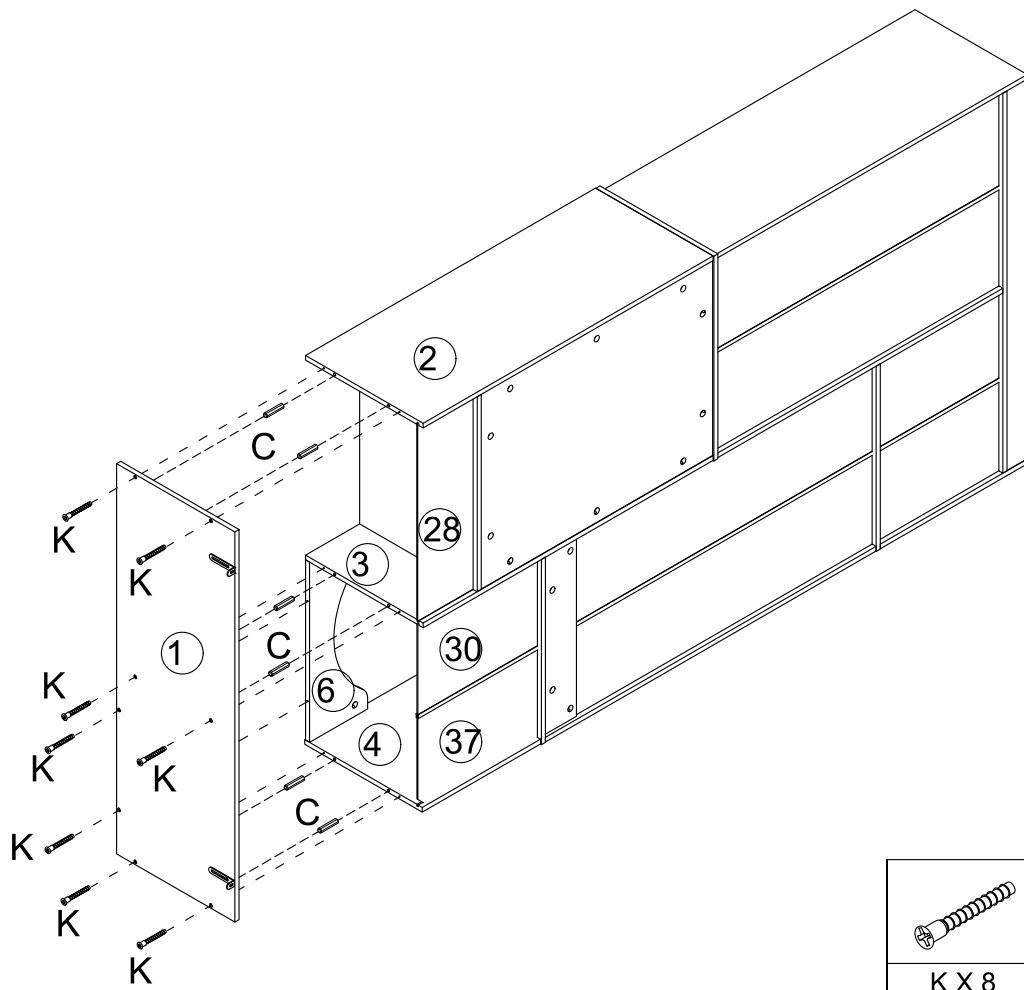

TX1



24.

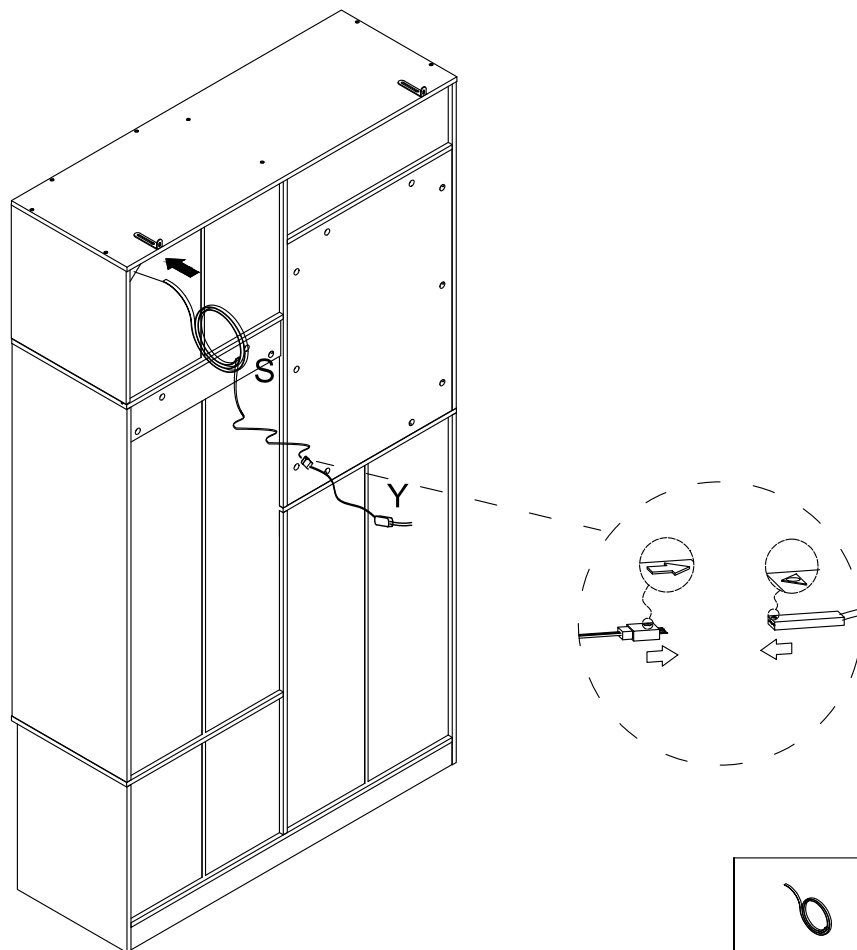

	
K X 8	C X 6

25.



	
S X 1	Y X 1

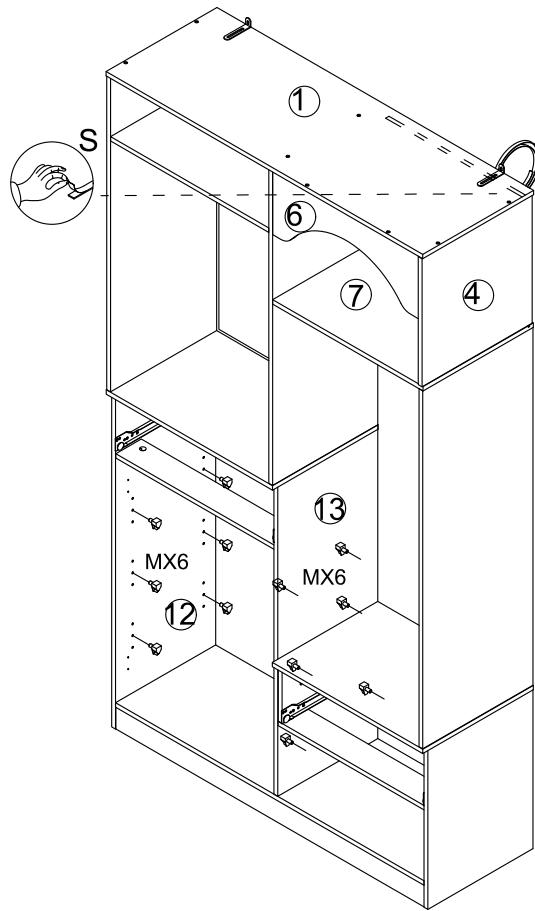

26.

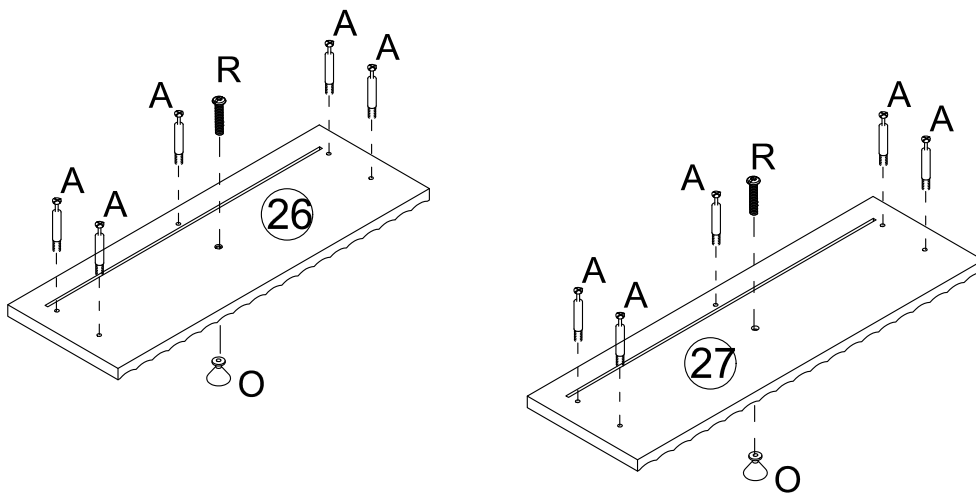

M X12

27.



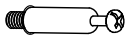

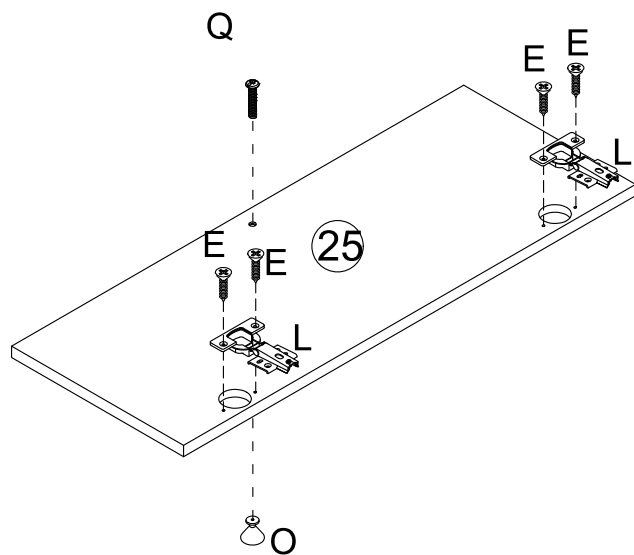

		
R X 2	O X 2	A X 10

28.



X 2

			
L X 4	E X 8	Q X 2	O X 2

29.

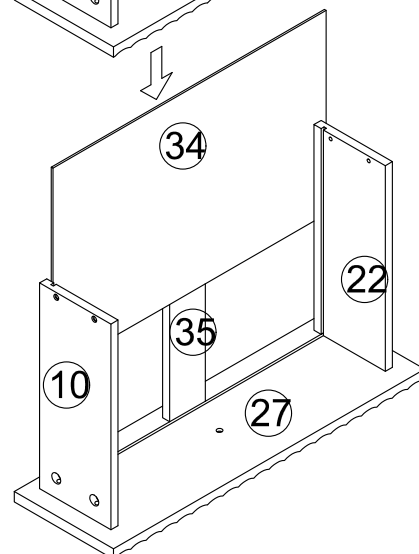
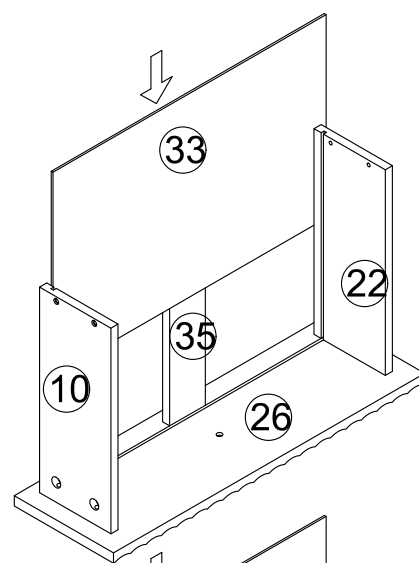
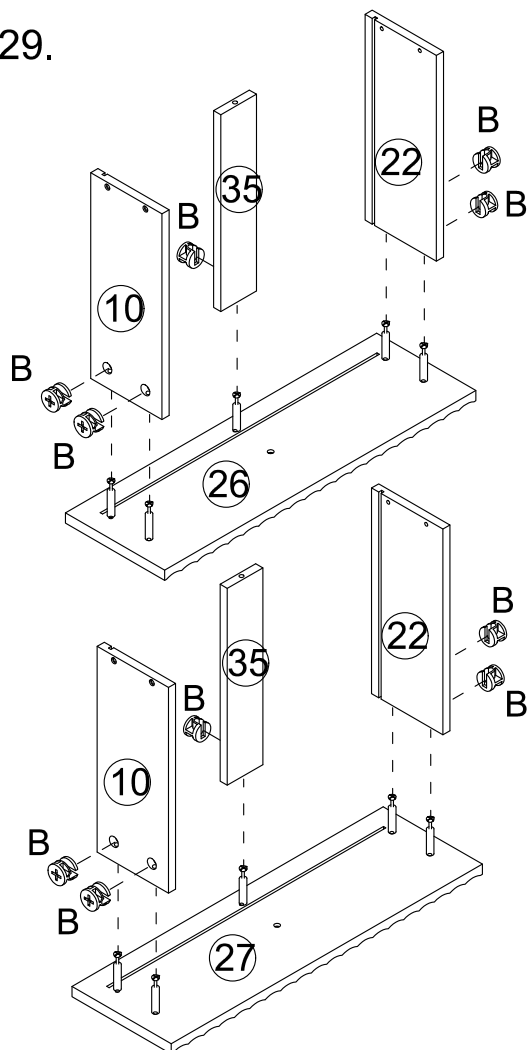



B X 10

30-33

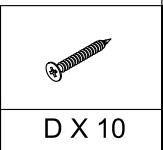
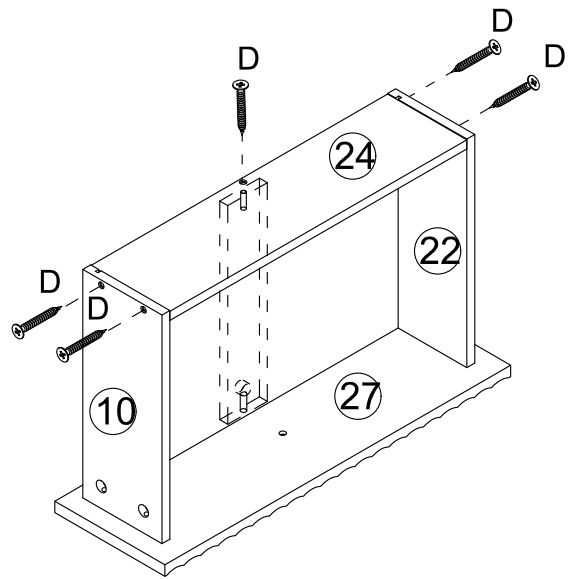
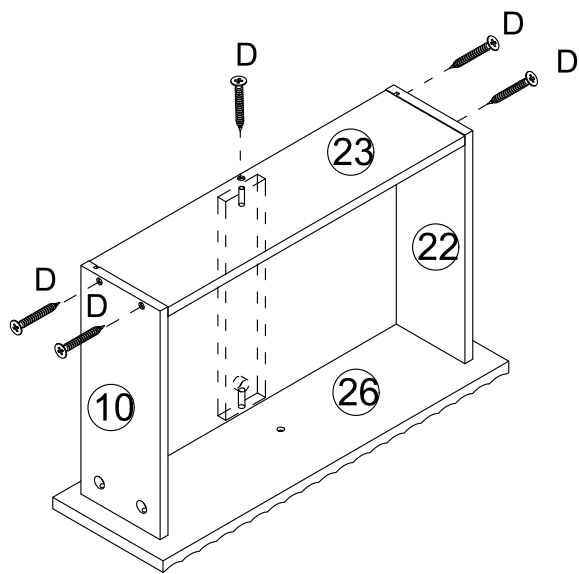
30.

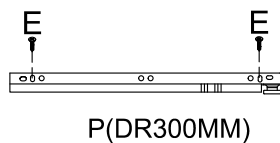
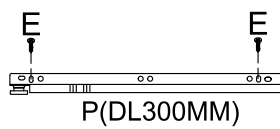
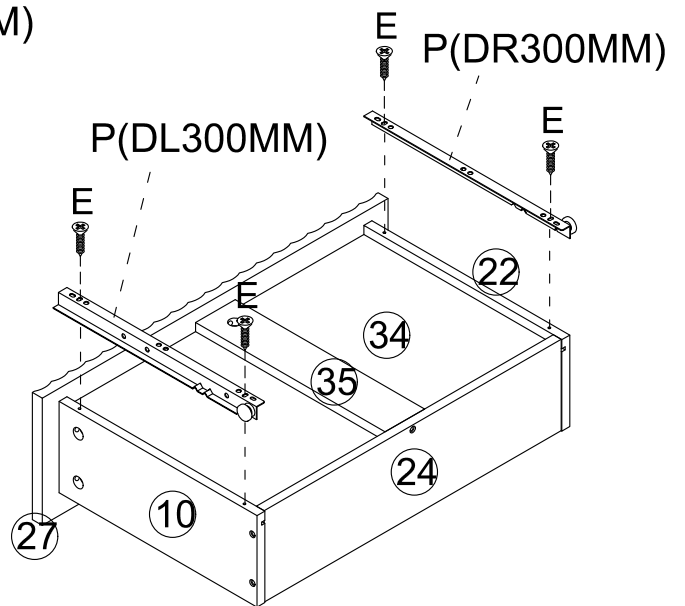
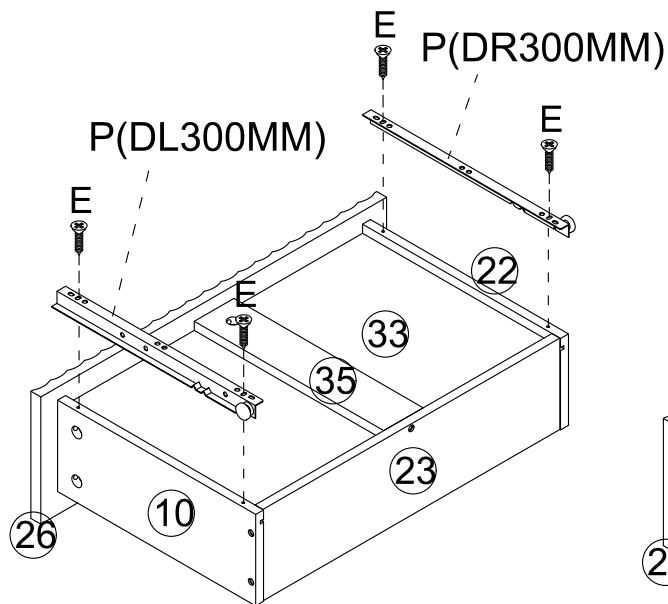

31.



E X 8	P-DR X 2	P-DL X 2

31-33

32.

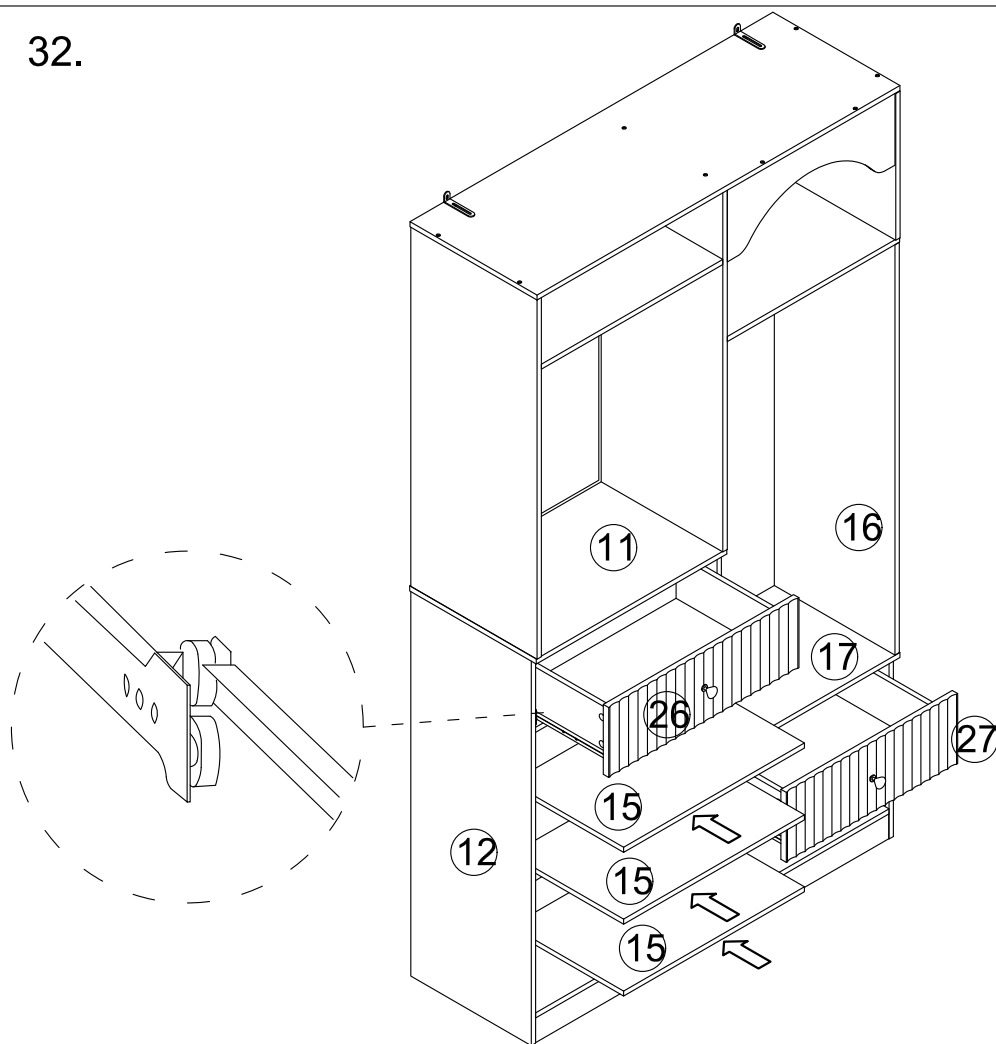

33.

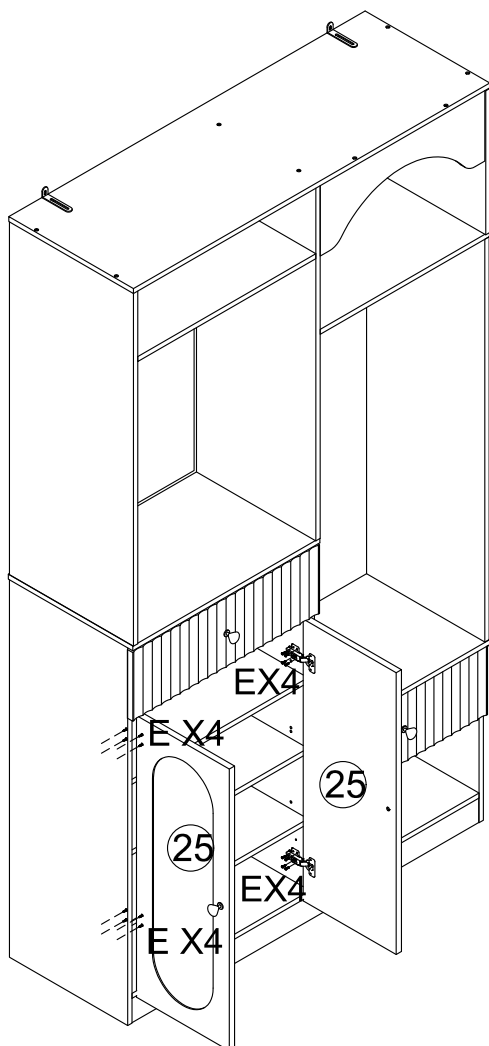

Note: It is forbidden to install the fixing hole screws first, otherwise it will lead to installation failure!

Remarque : Il est interdit d'installer d'abord les vis du trou de fixation, sinon cela entraînera un échec de l'installation!

Hinweis: Es ist verboten, zuerst die Befestigungslochschauben zu montieren, da dies sonst zu einem Installationsfehler führt!

- ① Installez d'abord les vis du trou de réglage
- ② Mettez la porte dans la bonne position
- ③ Montieren Sie abschließend die Befestigungslochschauben

- ① Install the adjustment hole screws first
- ② Get the door in the right position
- ③ Finally, install the fixing hole screws

- ① Montieren Sie zuerst die Einstellochschauben
- ② Bringen Sie die Tür in die richtige Position
- ③ Enfin, installez les vis du trou de fixation

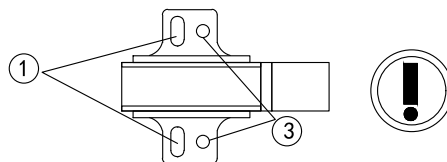

E X16

34.

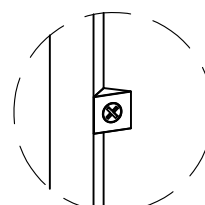
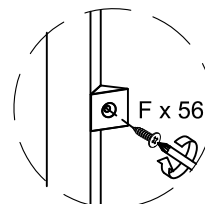
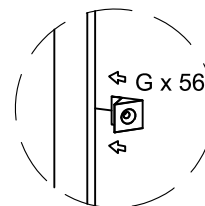
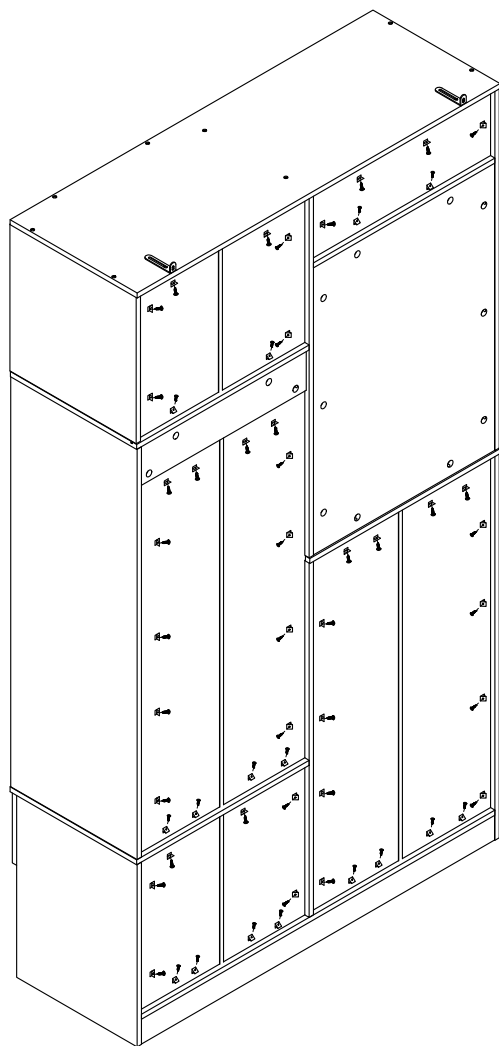

G X56	F X56

35.

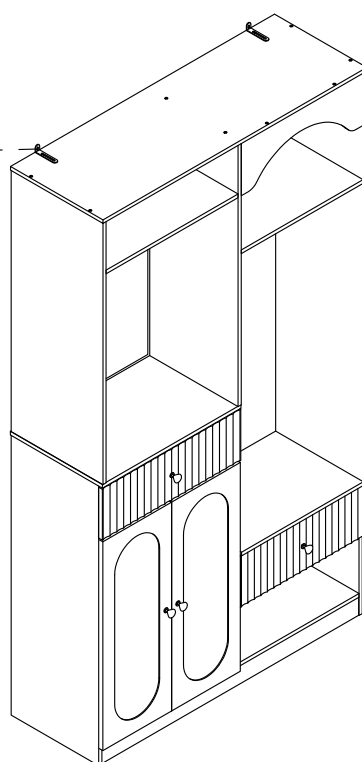
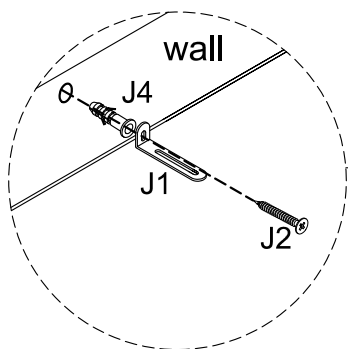
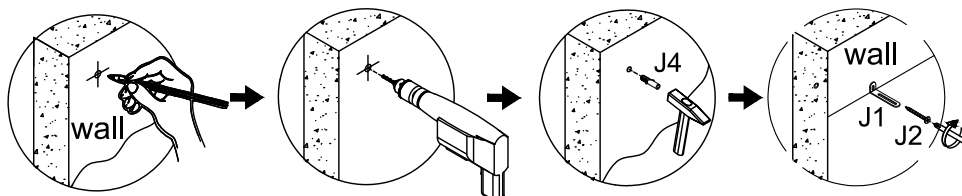

J-J4 X2	J-J2 X2