

Montageanleitung | Instructions de montage Assembly Instructions | Instrucciones de montaje

SKU NUMBER: N616P404277/N616P404278/N616P404279/N616P404280

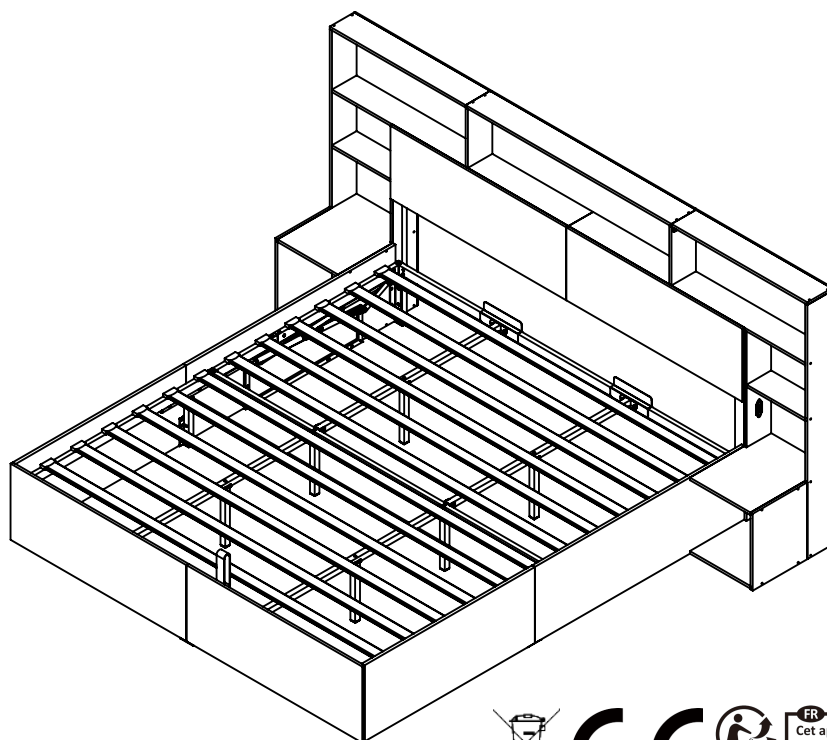

Points de collecte sur www.quefairemesdechets.fr
Privilégiez la réparation ou le don de votre appareil !

DE Unser Produkt wird Ihnen in 4 Paketen geliefert. Die Lieferzeiten dieser 4 Pakete können abweichen, bitte haben Sie etwas Geduld und vielen Dank für Ihr Verständnis.

UK Our product will be delivered to you in 4 packages. The delivery times of these 4 packages may differ, please be patient and thank you for your understanding.

FR Notre produit vous sera livré en 4 colis. Les délais de livraison de ces 4 colis peuvent différer, soyez patient et merci pour votre compréhension.

IT Il nostro prodotto verrà consegnato in 4 pacchi. I tempi di consegna di questi 4 pacchi possono variare; vi preghiamo di avere un po' di pazienza e vi ringraziamo per la vostra comprensione.

ES Nuestro producto se entregará en 4 paquetes. Los tiempos de entrega de estos 4 paquetes pueden variar; por favor, tenga un poco de paciencia y gracias por su comprensión.

NL Ons product wordt in 4 pakketten bij u geleverd. De levertijden van deze 4 pakketten kunnen verschillen, we vragen om uw geduld en bedanken u voor uw begrip.

SE Vår produkt kommer att levereras till dig i 4 paket. Leveranstiderna för dessa 4 paket kan variera, vi ber om ditt tålamod och tackar för din förståelse.

PL Nasz produkt zostanie dostarczony w 4 paczkach. Czas dostawy tych 4 paczek może się różnić, prosimy o cierpliwość i dziękujemy za zrozumienie.

English

IMPORTANT FOR GAS LIFT BEDS&MAINTAINANCE

- Please place the mattress on top of the bed frame.
- Please do not pull on the strap handles.
- Please press heavily to release the compressed gas.
- Periodically check all screw & fixings to ensure they are secure.
- When moving your product, carefully lift into place.
- Wipe clean with a slightly damp cloth- please do not use abrasive chemicals or bleach.
- Do NOT allow children to operate the lift mechanism.
- Do NOT allow children near the lift base when operating the mechanism.
- Do NOT stand inside the bed or the internal storage base.
- Do NOT overload the internal storage base.
- DO NOT jump on the product or any of its parts.

Deutsch

WICHTIG FÜR GASLIFT-BETTEN&WARTUNG

- Bitte legen Sie die Matratze oben auf den Bettrahmen.
- Bitte ziehen Sie nicht an den Gurtgriffen.
- Bitte drücken Sie kräftig, um das komprimierte Gas freizusetzen.
- Überprüfen Sie regelmäßig alle Schrauben und Befestigungen, um sicherzustellen, dass sie sicher sind.
- Wenn Sie Ihr Produkt bewegen, heben Sie es vorsichtig an seinen Platz.
- Mit einem leicht feuchten Tuch abwischen - bitte keine scheuernden Chemikalien oder Bleichmittel verwenden.
- Erlauben Sie Kindern NICHT, den Hebemechanismus zu bedienen.
- Lassen Sie Kinder NICHT in die Nähe des Liftsockels, wenn Sie den Mechanismus bedienen.
- Stellen Sie sich NICHT in das Bett oder in die Innenablage.
- Überlasten Sie den internen Liftsockel NICHT.
- Springen Sie NICHT auf das Produkt oder eines seiner Teile.

Français

IMPORTANT POUR LES LITS À RELEVAGE DE GAZ&MAINTENANCE

- Veuillez placer le matelas sur le dessus du cadre de lit.
- Ne tirez pas sur les poignées de la sangle.
- Appuyez fortement pour libérer le gaz comprimé.
- Vérifiez régulièrement que toutes les vis et fixations sont bien en place.
- Lorsque vous déplacez votre produit, soulevez-le avec précaution pour le mettre en place.
- Nettoyez avec un chiffon légèrement humide - n'utilisez pas de produits chimiques abrasifs ou d'eau de Javel.
- Ne laissez pas les enfants utiliser le mécanisme de levage.
- Ne laissez pas les enfants s'approcher de la base de levage lorsqu'ils actionnent le mécanisme.
- Ne vous tenez PAS à l'intérieur du lit ou de la base de stockage interne.
- Ne surchargez pas la base de stockage interne.
- Ne pas sauter sur le produit ou l'une de ses parties.

Italiano

IMPORTANTE PER I LETTI CON SOLLEVAMENTO A GAS E LA MANUTENZIONE

- Posizionare il materasso sopra la struttura del letto.
- Non tirare le maniglie della cinghia.
- Premere con forza per rilasciare il gas compresso.
- Controllare periodicamente tutte le viti e i fissaggi per assicurarsi che siano saldi.
- Quando si sposta il prodotto, sollevarlo con cautela.
- Pulire con un panno leggermente umido, senza usare prodotti chimici abrasivi o candeggina.
- NON permettere ai bambini di azionare il meccanismo di sollevamento.
- NON permettere ai bambini di avvicinarsi alla base di sollevamento quando si aziona il meccanismo.
- NON sostare all'interno del letto o della base di contenimento interna.
- NON sovraccaricare la base di contenimento interna.
- NON saltare sul prodotto o sulle sue parti.

Español

IMPORTANTE PARA LAS CAMAS ELEVADORAS DE GAS&MANTENIMIENTO

- Coloque el colchón sobre el somier.
- No tire de las asas de la correa.
- Presione con fuerza para liberar el gas comprimido.
- Compruebe periódicamente que todos los tornillos y fijaciones estén bien sujetos.
- Al mover el producto, levántelo con cuidado para colocarlo en su sitio.
- Limpie con un paño ligeramente humedecido; no utilice productos químicos abrasivos ni lejía.
- NO permita que los niños accionen el mecanismo de elevación.
- NO permita que los niños se acerquen a la base elevadora cuando accionen el mecanismo.
- NO se ponga de pie dentro de la cama o de la base de almacenamiento interna.
- NO sobrecargue el somier.
- NO salte sobre el producto ni sobre ninguna de sus piezas.

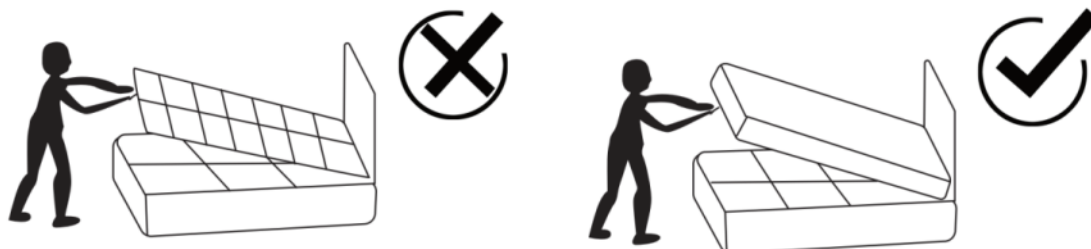

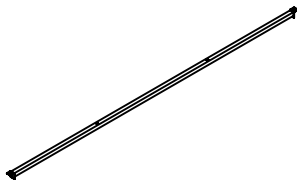
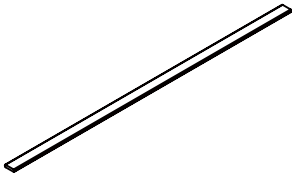
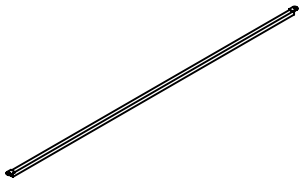
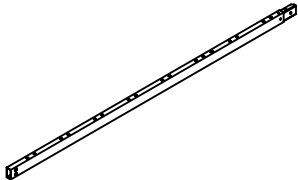
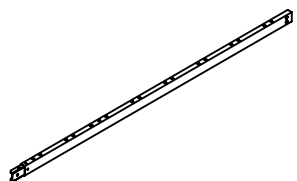
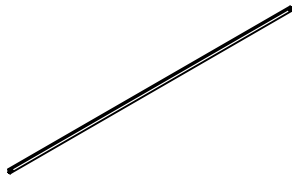
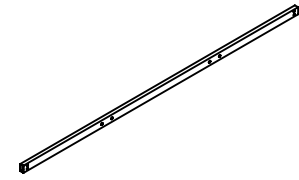
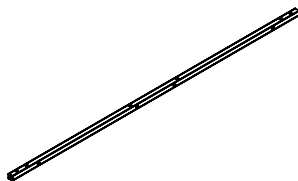
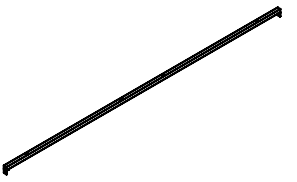
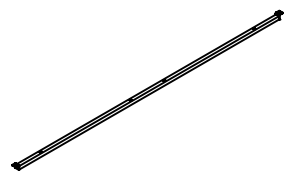
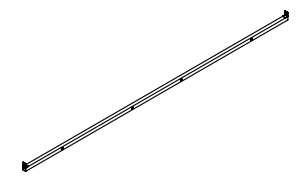
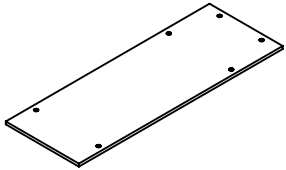

Part List N616P404277

<p>④ X1</p> 	<p>⑤ X12</p> 	<p>⑥ X1</p> 	<p>⑩ X1</p> 
<p>⑪ X1</p> 	<p>⑬ X1</p> 	<p>⑯ X2</p> 	<p>⑰ X1</p> 
<p>⑳ X1</p> 	<p>㉑ X1</p> 	<p>㉒ X1</p> 	<p>㉔ X2</p> 

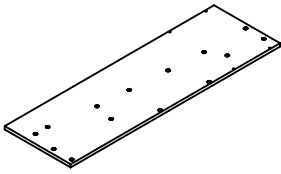
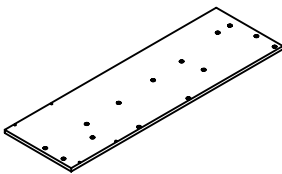
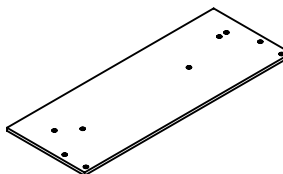
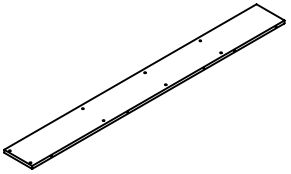
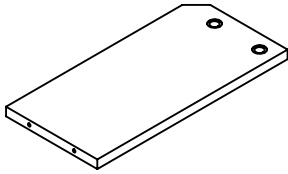
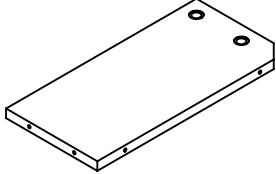
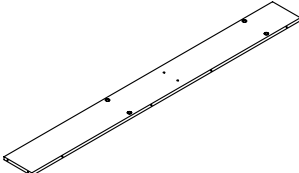
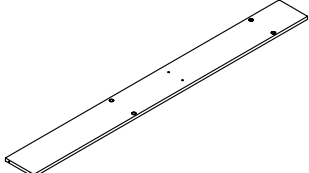
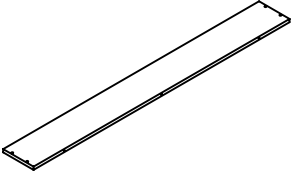
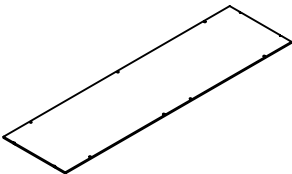
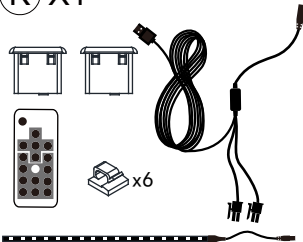
Part List N616P404278

<p>31 X1</p> 	<p>32 X1</p> 	<p>35 X1</p> 	<p>39 X2</p> 
<p>47 X1</p> 	<p>48 X1</p> 	<p>49 X1</p> 	<p>50 X1</p> 
<p>53 X1</p> 	<p>54 X1</p> 	<p>K X1</p> 	

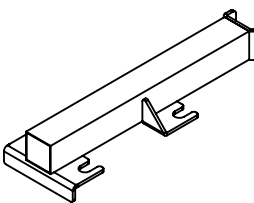
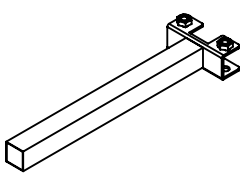
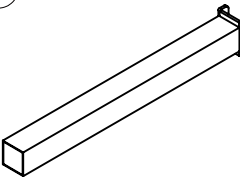
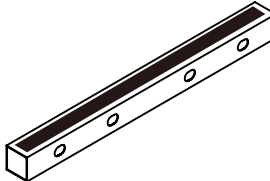
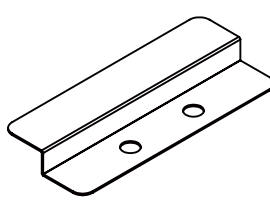
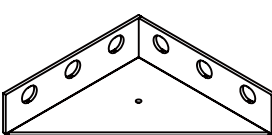
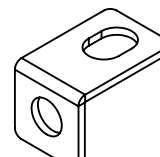
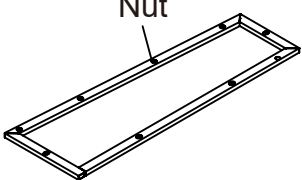
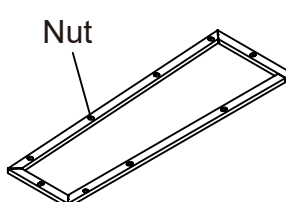
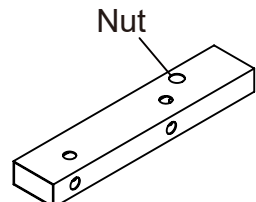
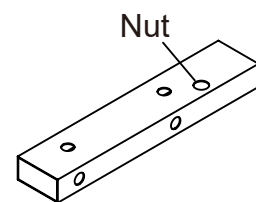
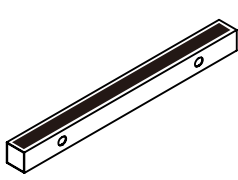
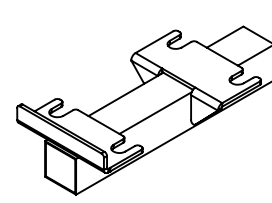
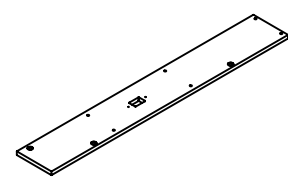
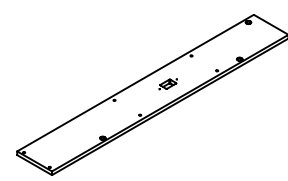
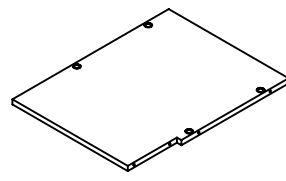
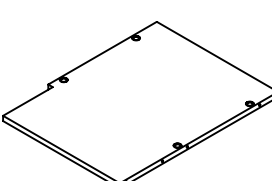
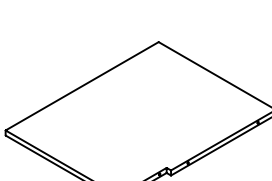
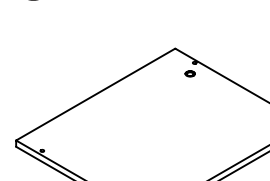
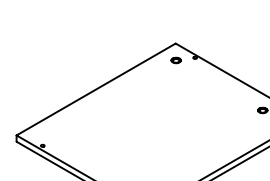
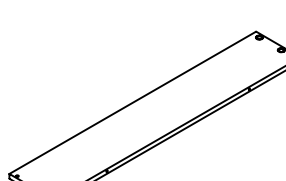
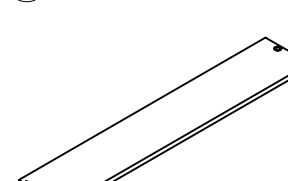
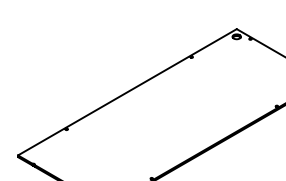
Part List N616P404279



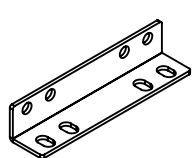
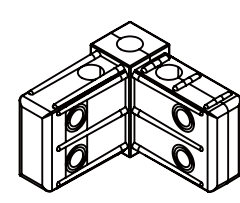
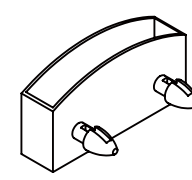
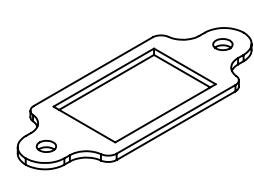



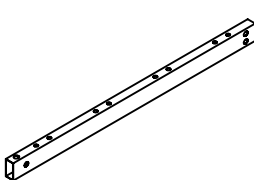
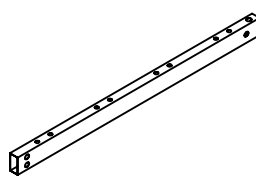
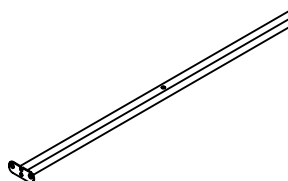
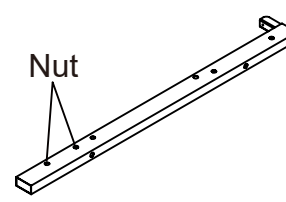
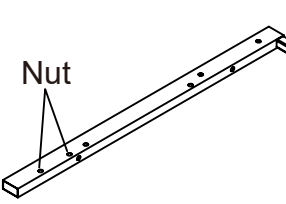
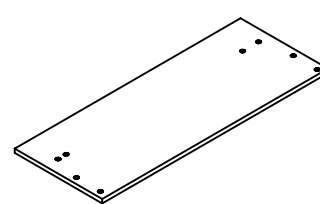
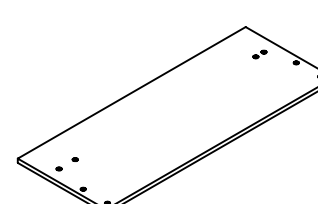
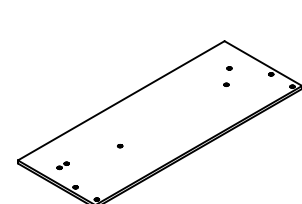
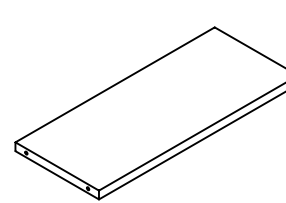
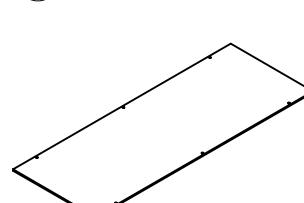
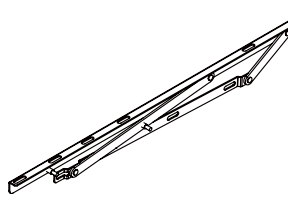
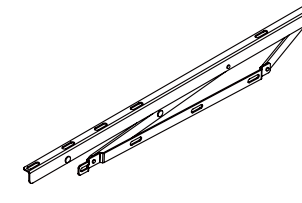
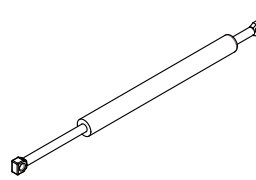





<p>③ X2</p> 	<p>⑧ X2</p> 	<p>⑨ X4</p> 	<p>⑫ X2</p> 
<p>⑭ X2</p> 	<p>⑮ X2</p> 	<p>⑳ X12</p> 	<p>㉑ X1</p> <p>Nut</p> 
<p>㉒ X1</p> <p>Nut</p> 	<p>㉓ X1</p> <p>Nut</p> 	<p>㉔ X1</p> <p>Nut</p> 	<p>㉕ X1</p> 
<p>㉙ X1</p> 	<p>㉟ X1</p> 	<p>㊳ X1</p> 	<p>㊴ X1</p> 
<p>㊵ X1</p> 	<p>㊶ X2</p> 	<p>㊷ X1</p> 	<p>㊸ X1</p> 
<p>㊹ X1</p> 	<p>㊺ X1</p> 	<p>㊻ X2</p> 	<p>㊼ X1</p> 

<p>Ⓛ X2</p> 	<p>Ⓨ X4</p> 	<p>Ⓩ X24</p> 	<p>ⓐ X2</p> 
---	---	---	---

Part List N616P404280

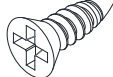
<p>① X1</p> 	<p>② X1</p> 	<p>⑦ X4</p> 	<p>⑰ X1</p> <p>Nut</p> 
<p>⑱ X1</p> <p>Nut</p> 	<p>③③ X1</p> 	<p>③④ X1</p> 	<p>③⑥ X1</p> 
<p>④⑥ X2</p> 	<p>⑤⑥ X2</p> 	<p>Ⓚ① X1</p> 	<p>Ⓚ② X1</p> 
<p>Ⓚ③ X2</p> 			

Hardware List N616P404279

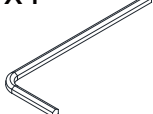
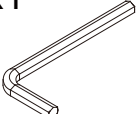
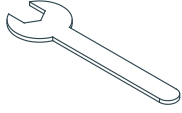
<p>A x38</p>  <p>M8X12</p>	<p>B x50</p>  <p>M8X14</p>	<p>C x18</p>  <p>M8X20</p>	<p>D x8</p>  <p>M8X25</p>	<p>E x16</p>  <p>M8X30</p>
<p>F x32</p>  <p>M8X35</p>	<p>G x8</p>  <p>M8X50</p>	<p>H x4</p>  <p>M8X60</p>	<p>I x4</p>  <p>ST4X14</p>	<p>J x39</p>  <p>M5X30</p>
<p>M x52</p>  <p>M5X40</p>	<p>N x4</p>  <p>M8</p>	<p>O x1</p>  <p>M5</p>	<p>P x1</p>  <p>M8</p>	<p>Q x1</p> 

1

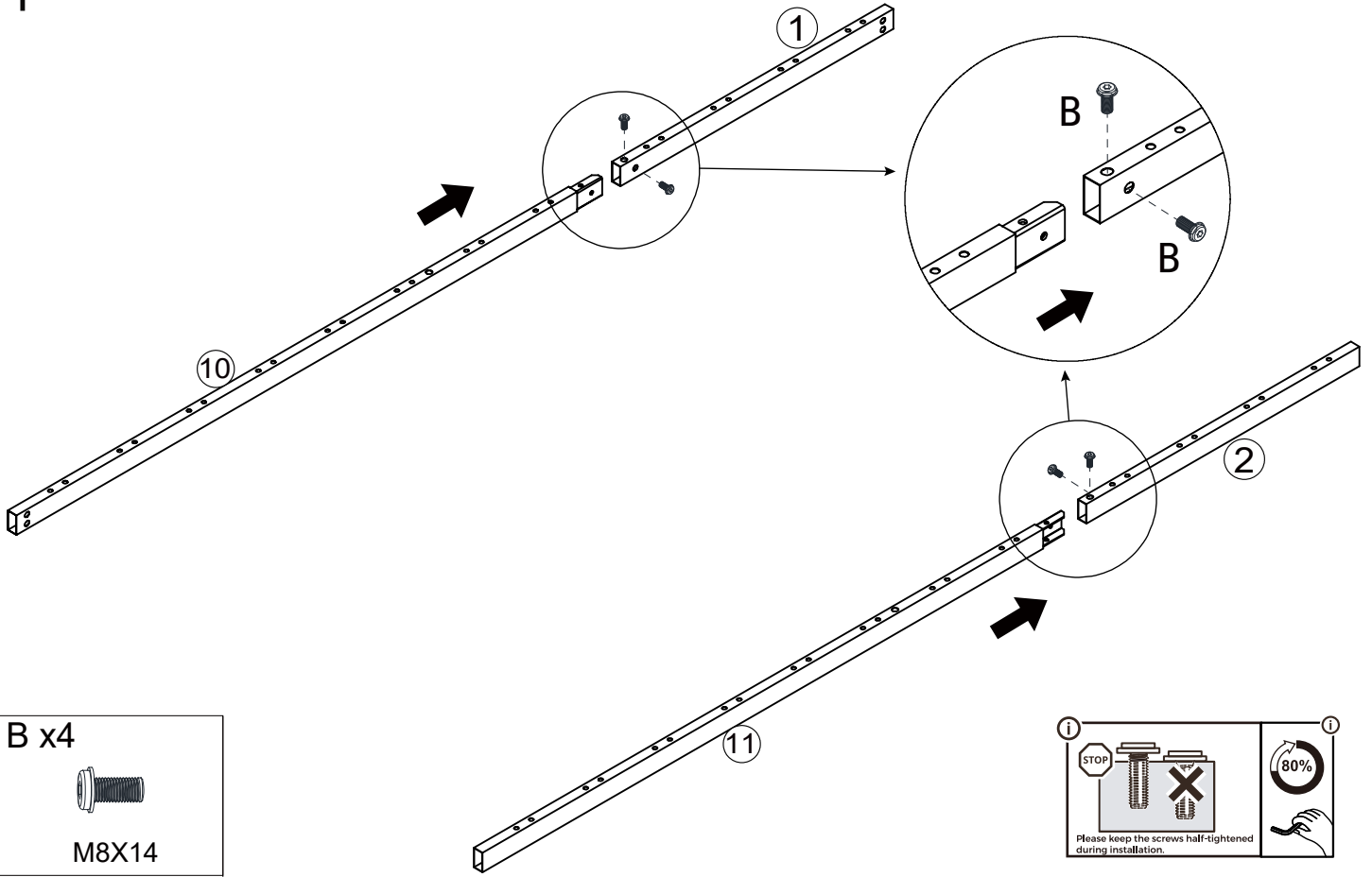

2

x2

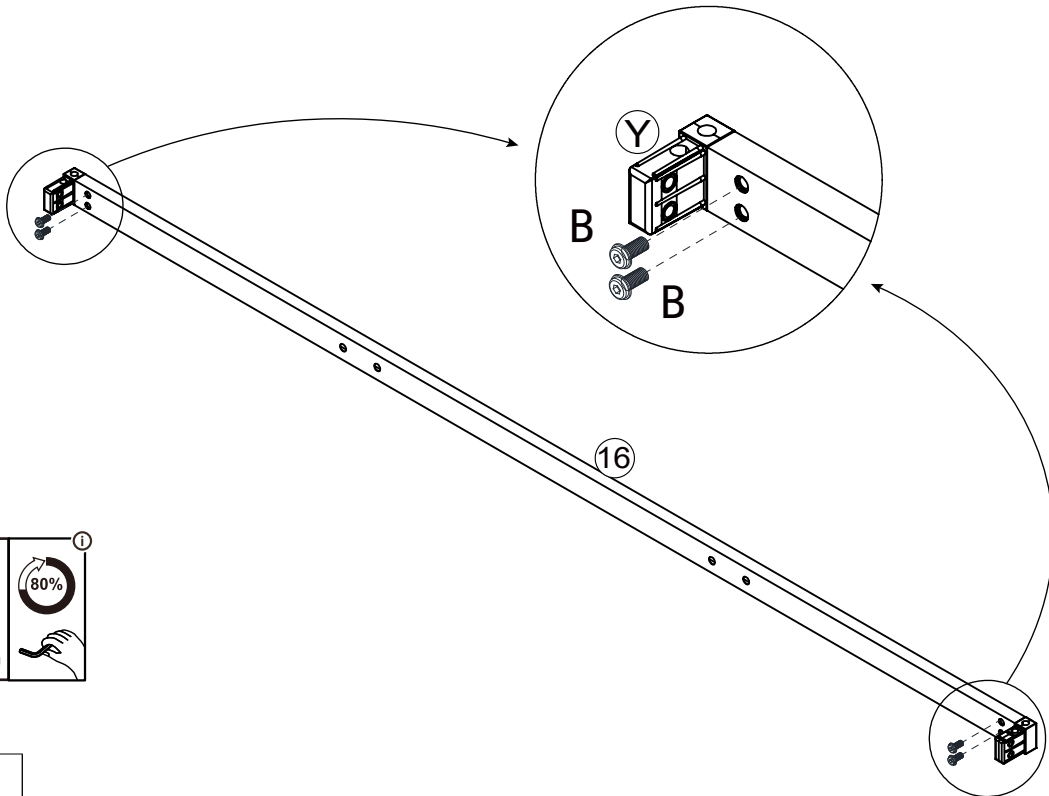

3

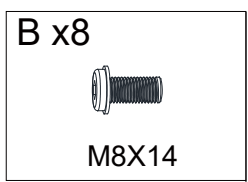
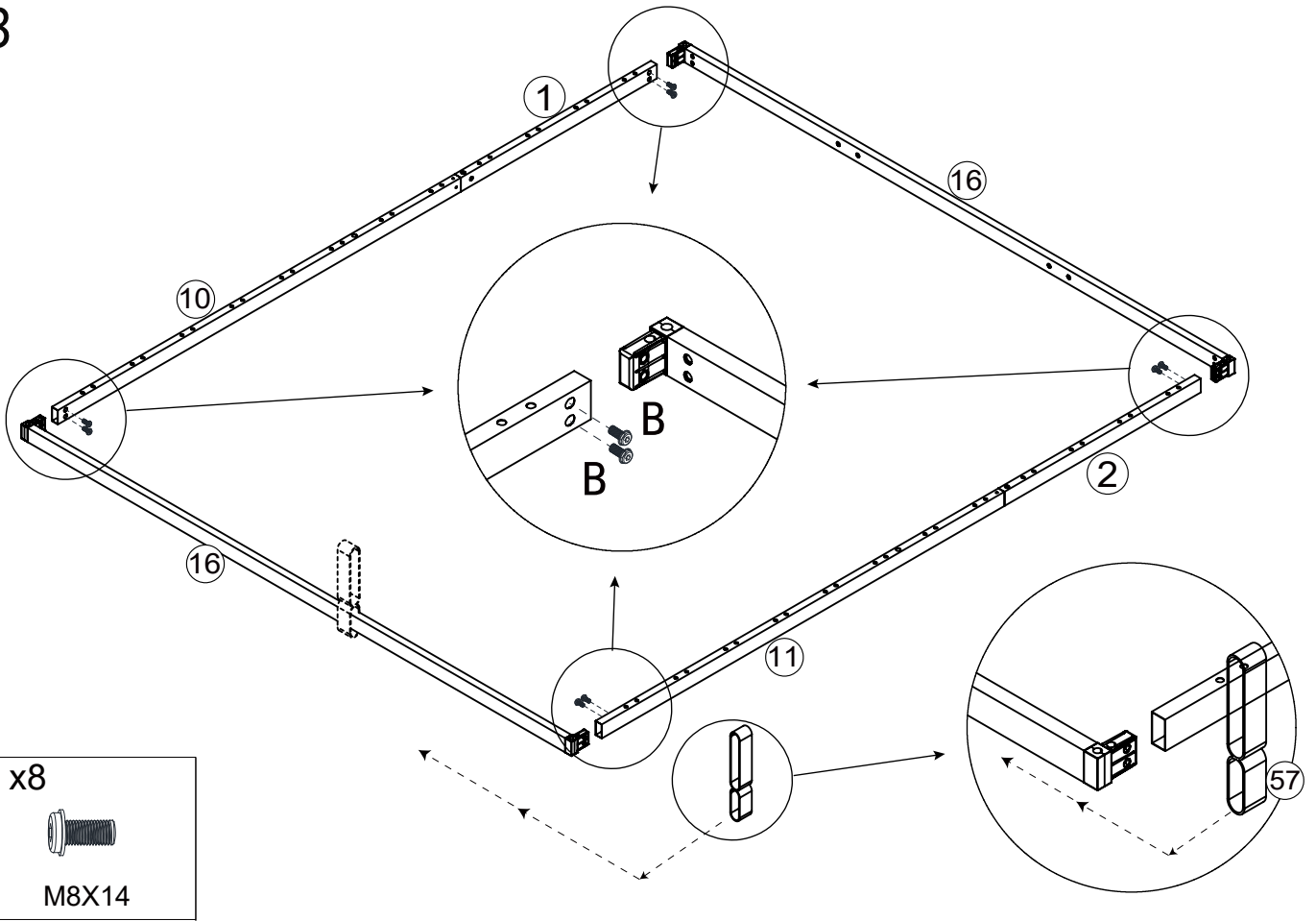

4
x2

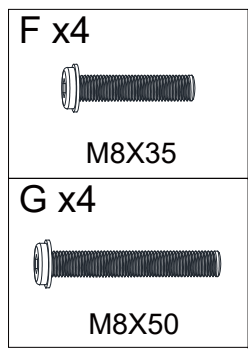
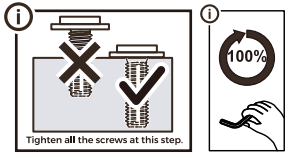
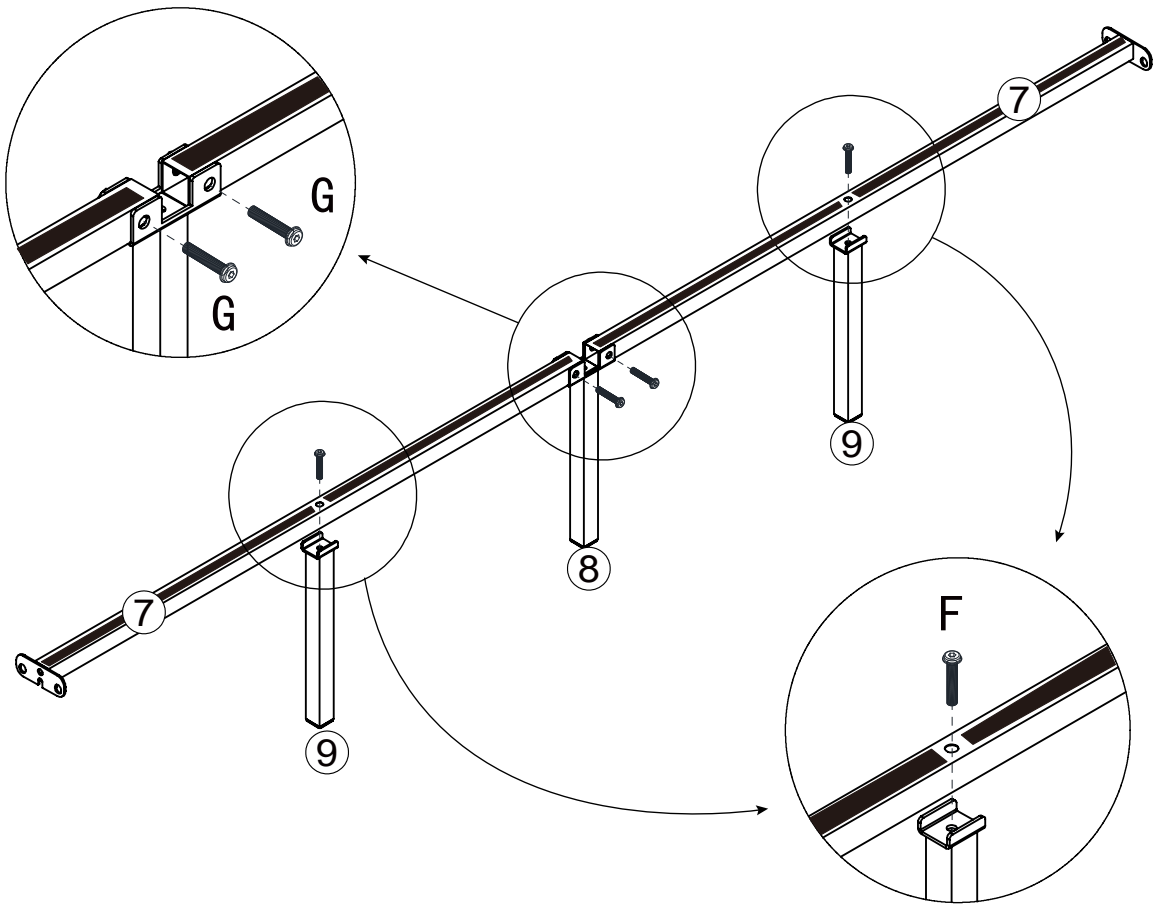

5

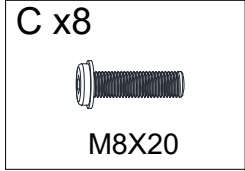
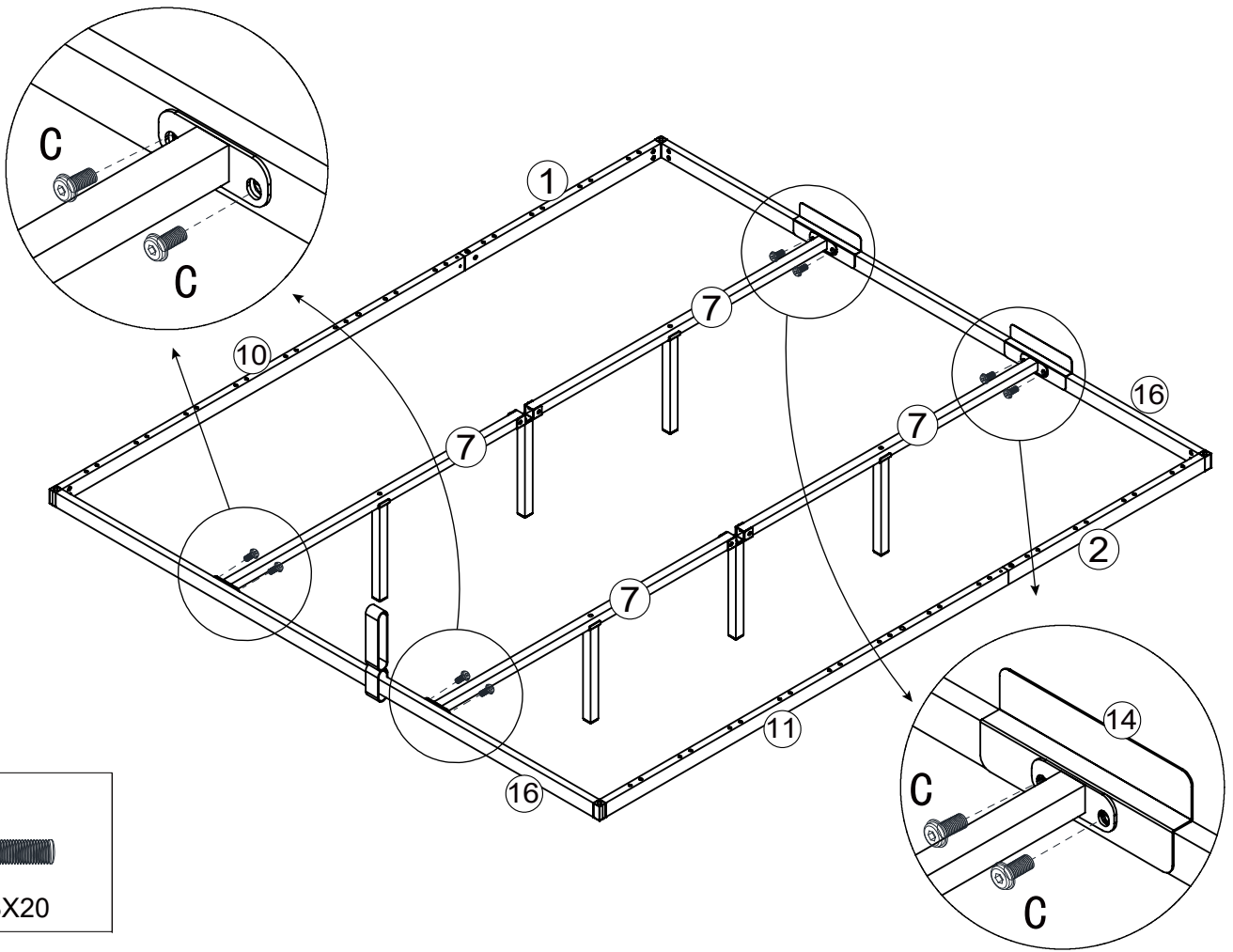

6

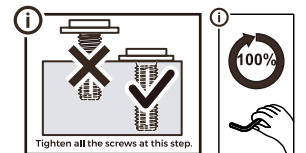
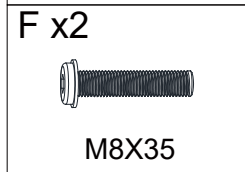
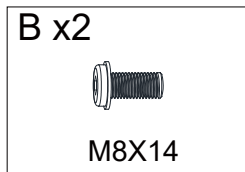
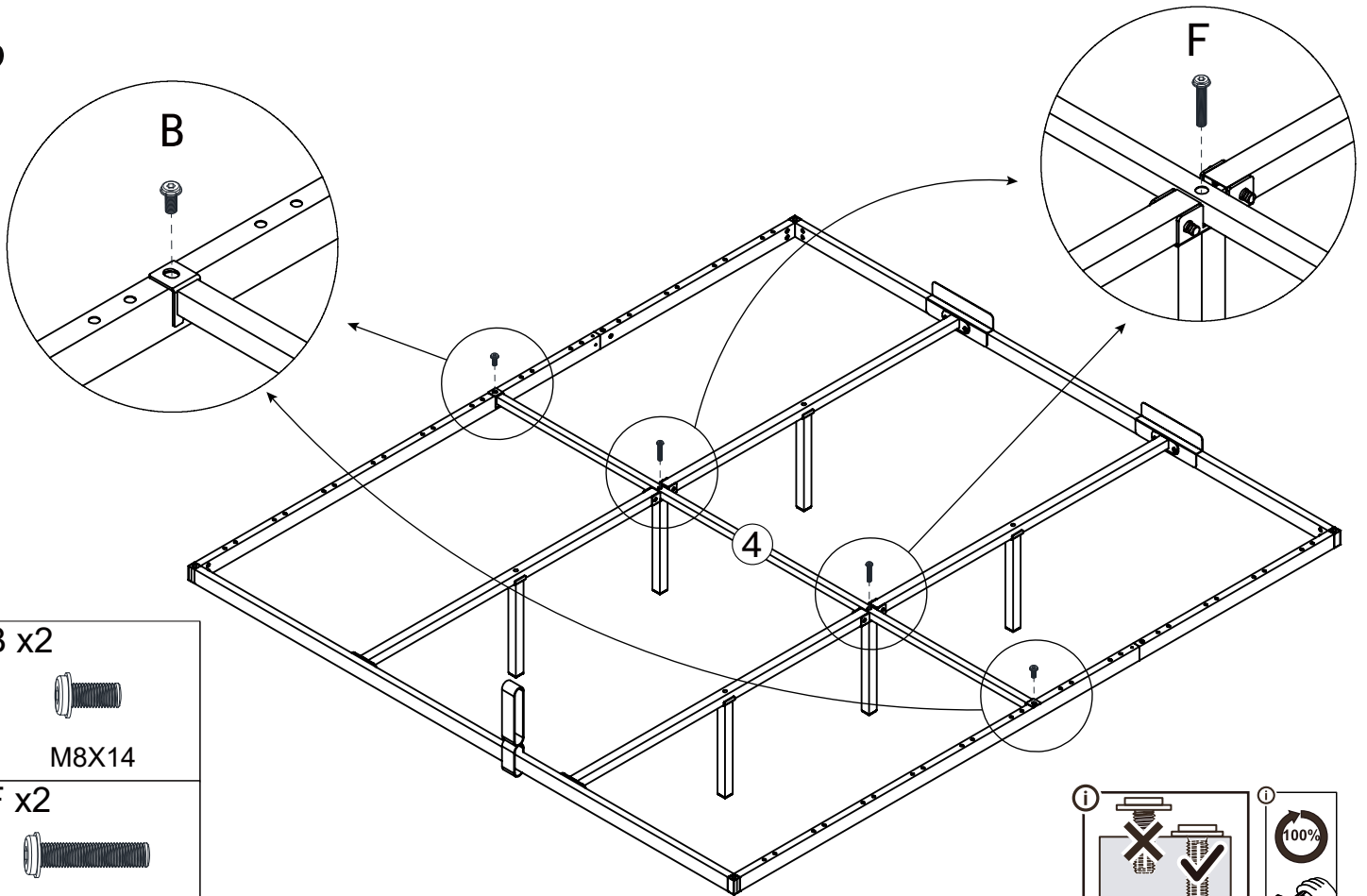

7

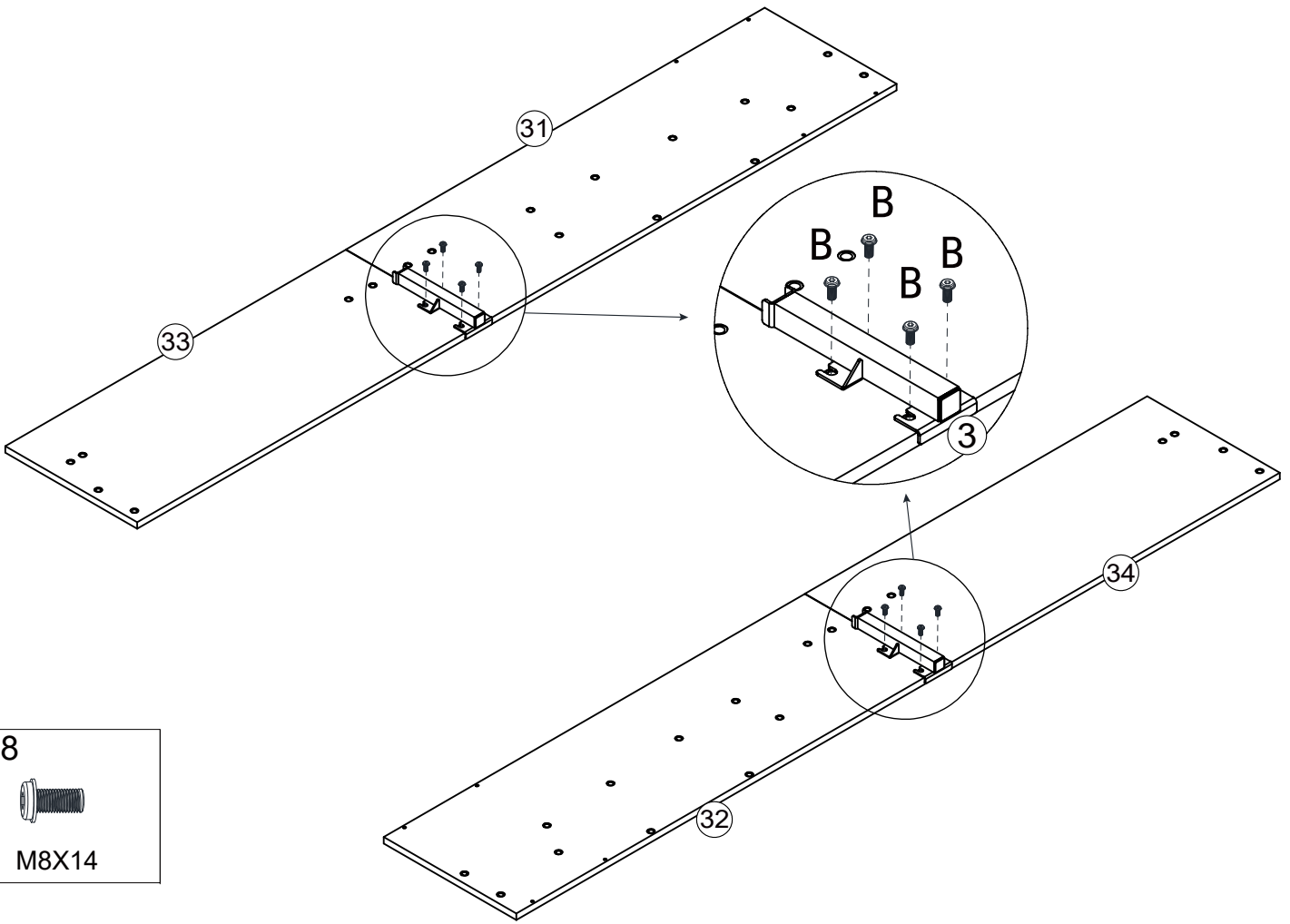

B x8



M8X14

8

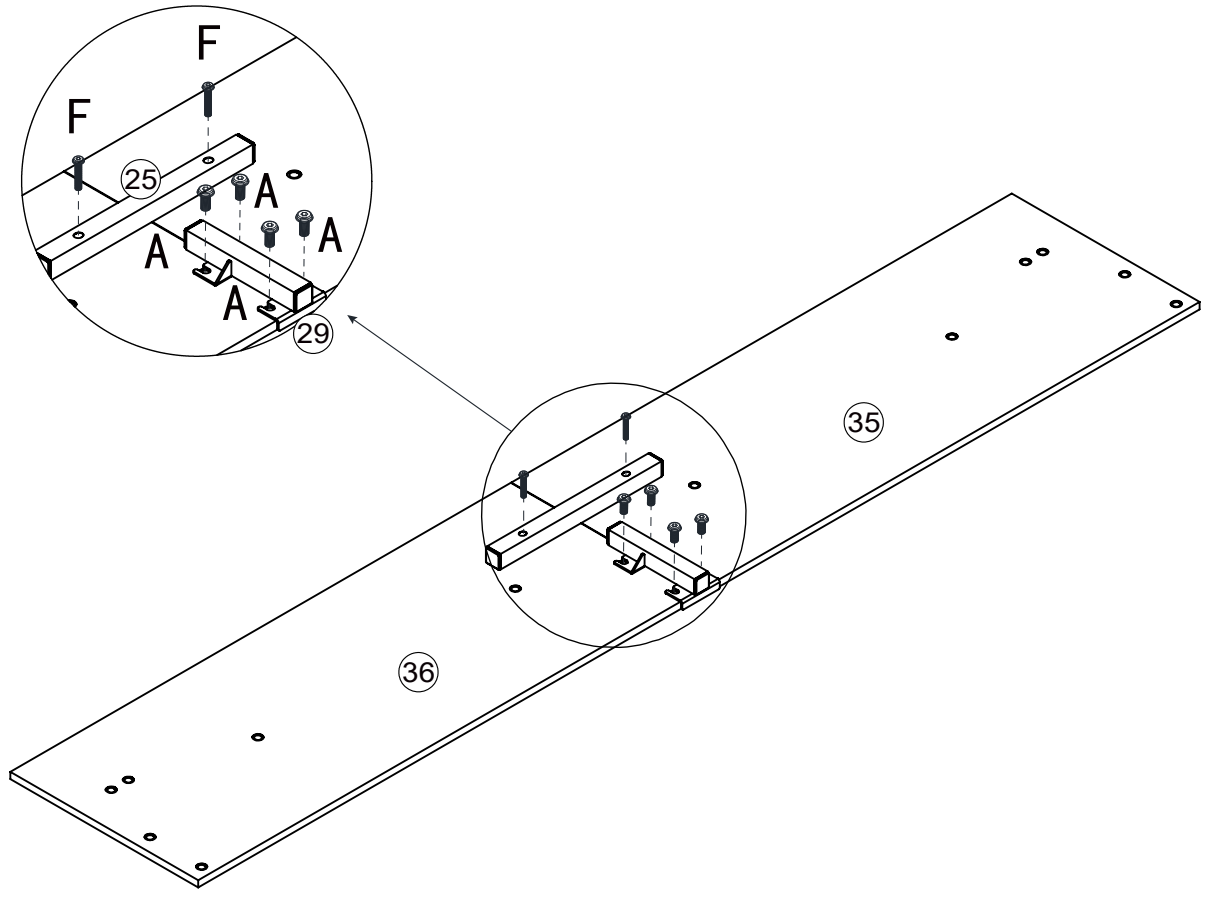

A x4



M8X12



F x2

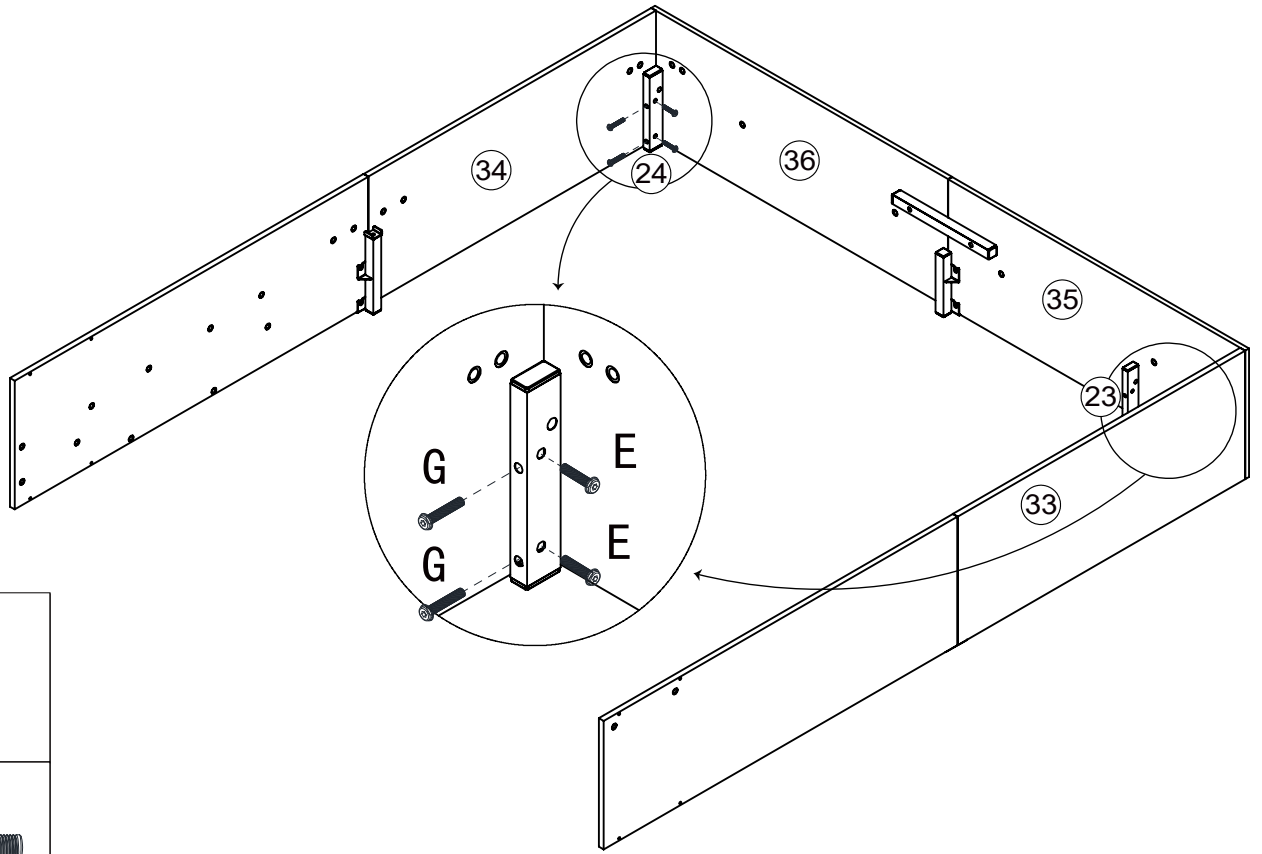

M8X35

9



E x4

M8X30
G x4

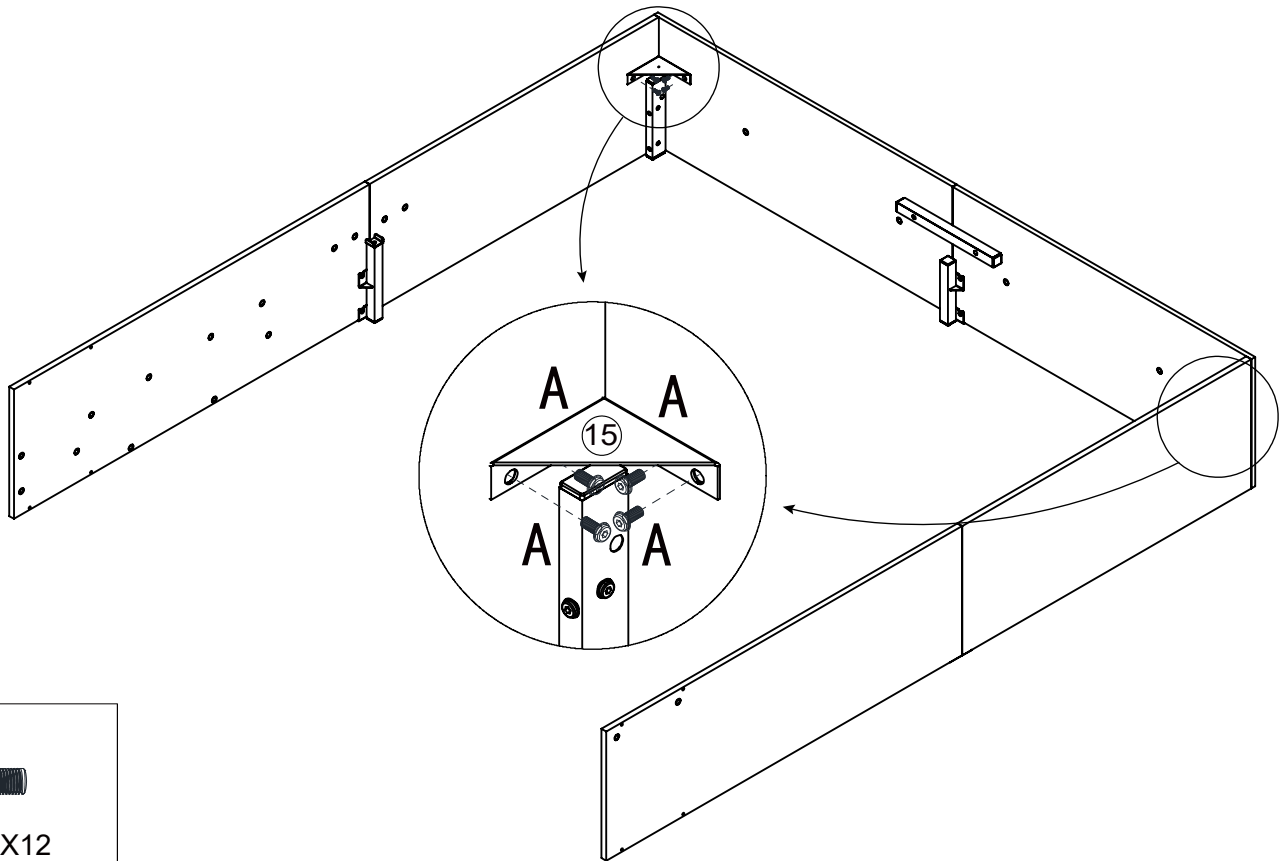
M8X50

10



A x8

M8X12

11

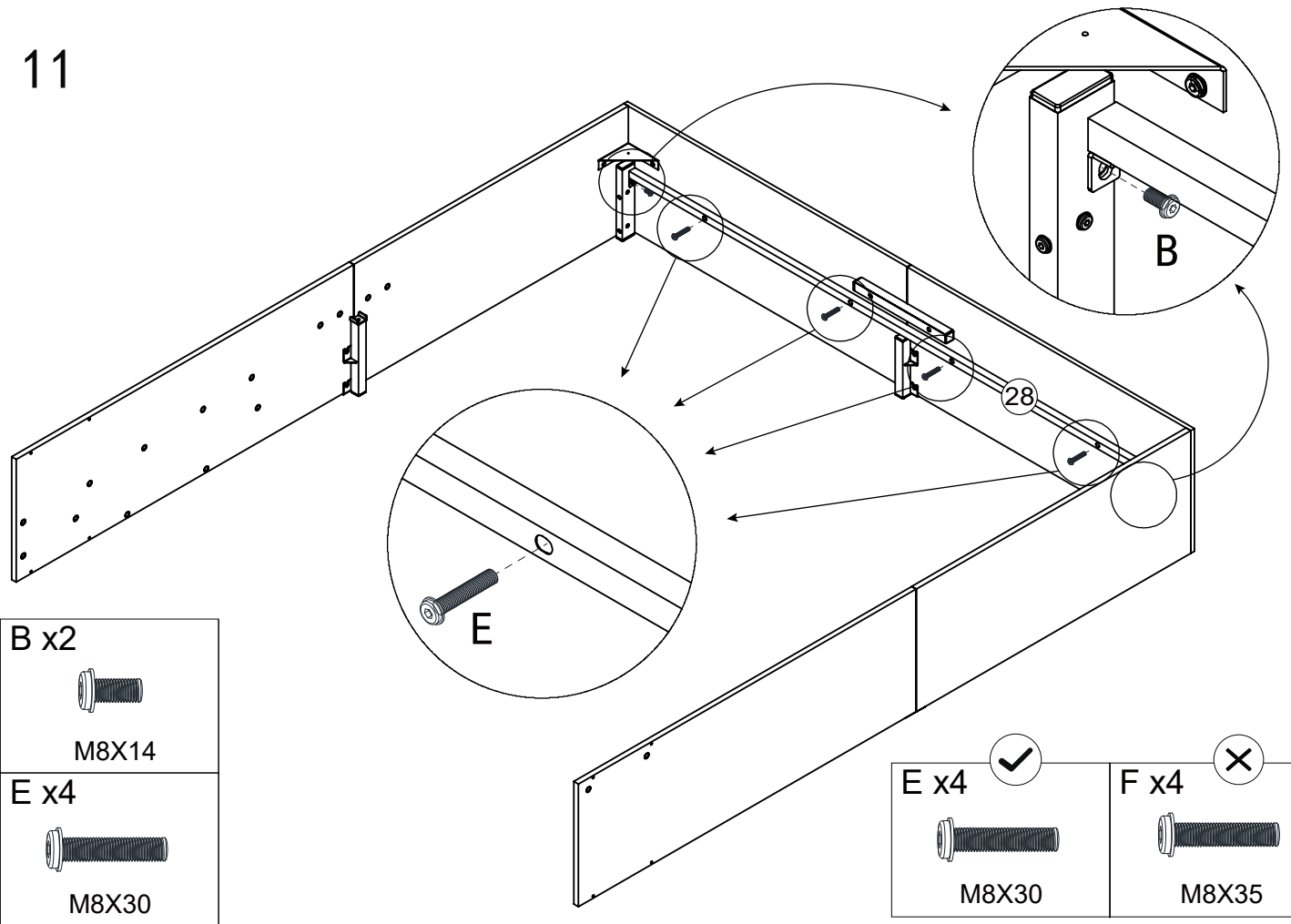

12

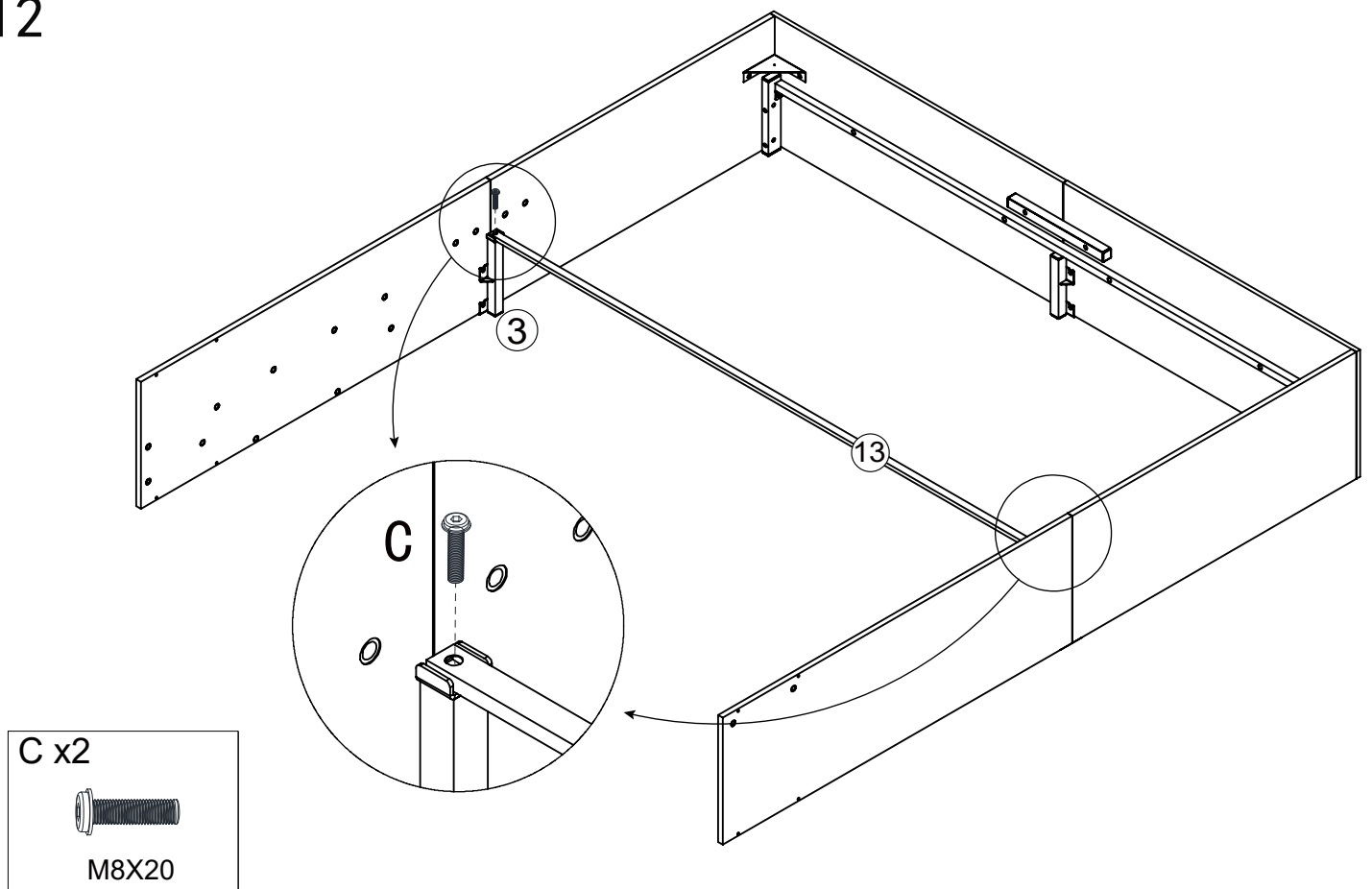

13

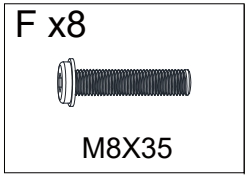
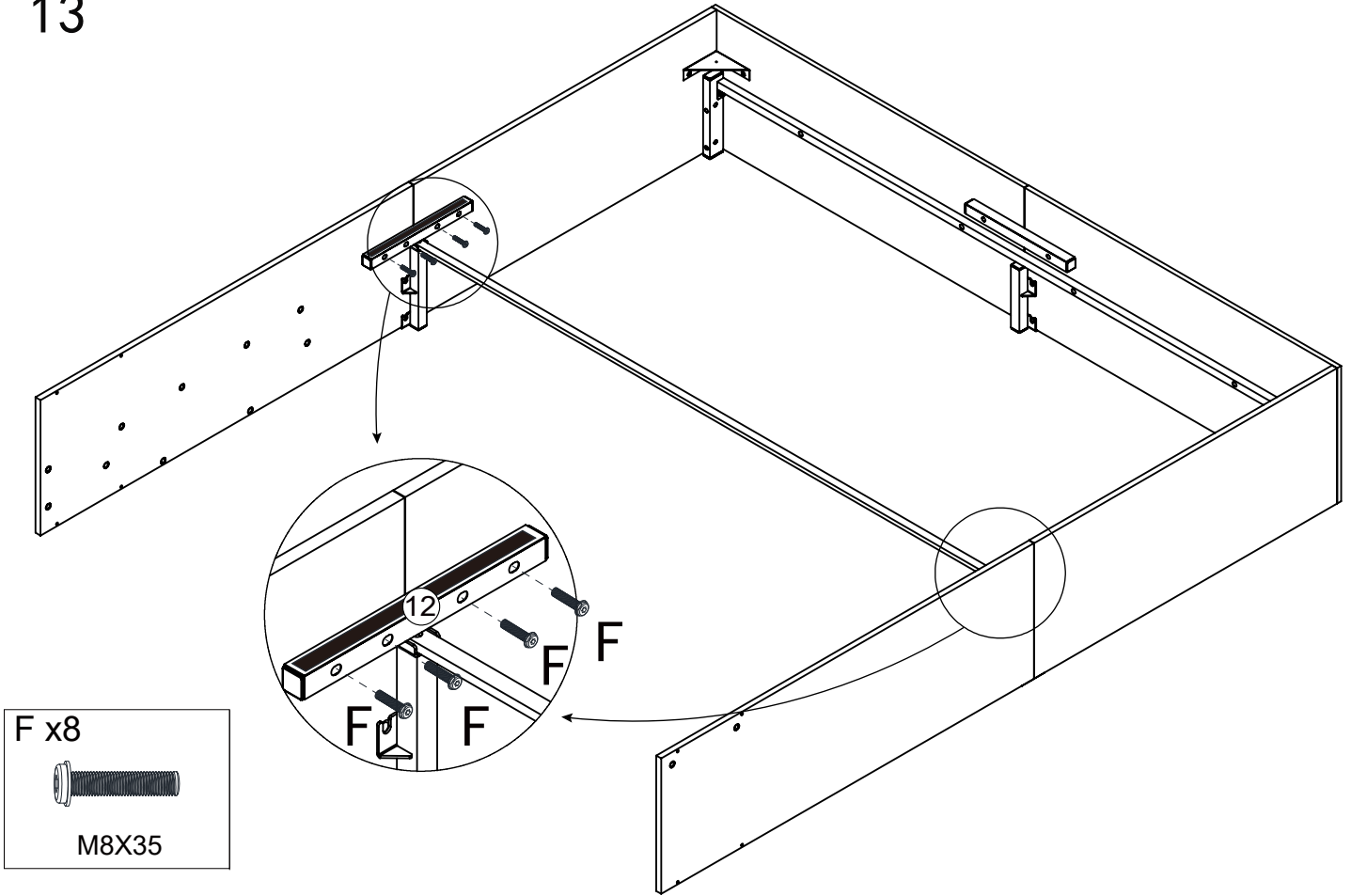

14

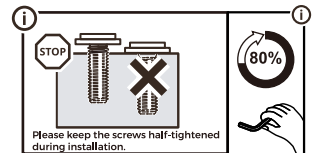
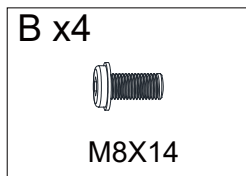
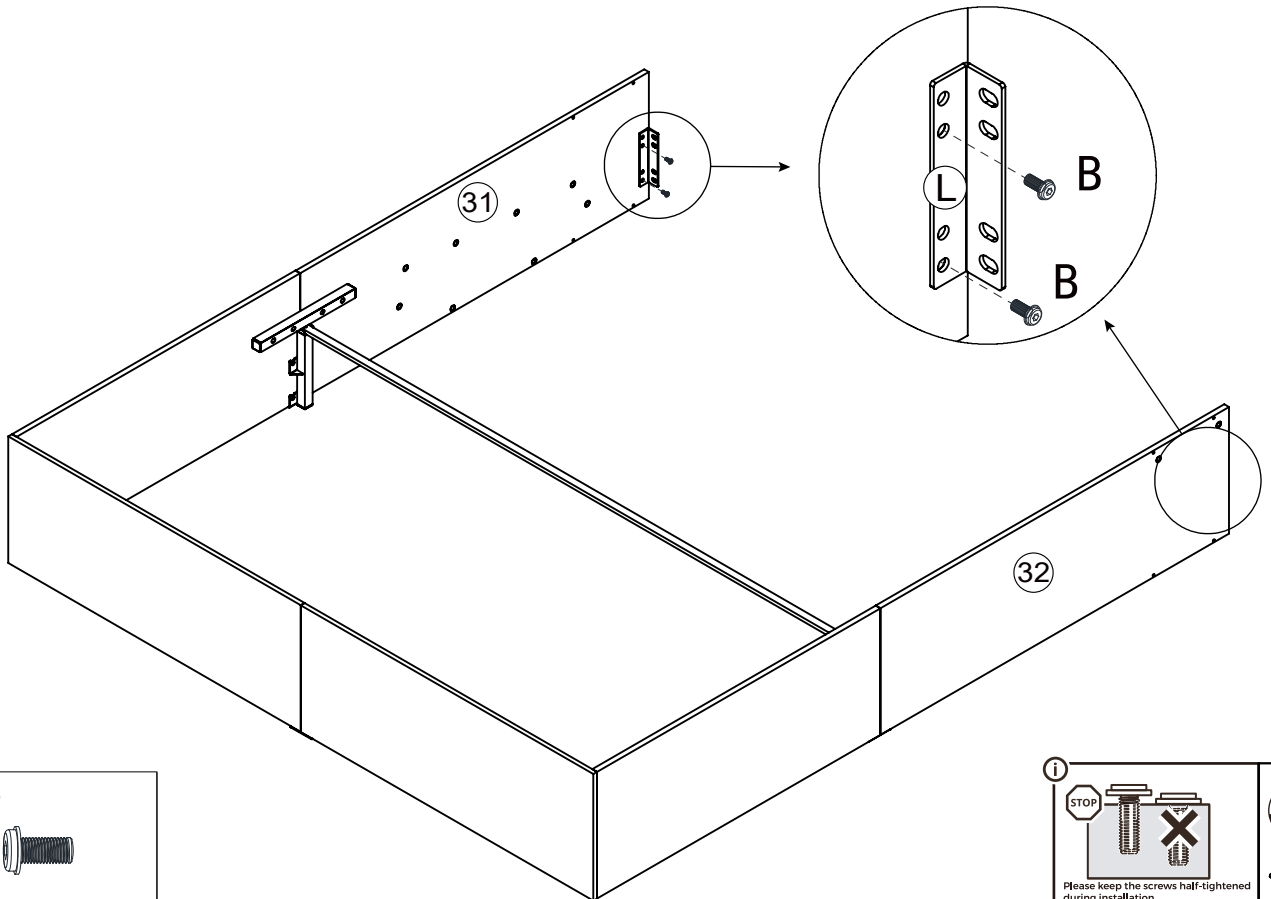

15

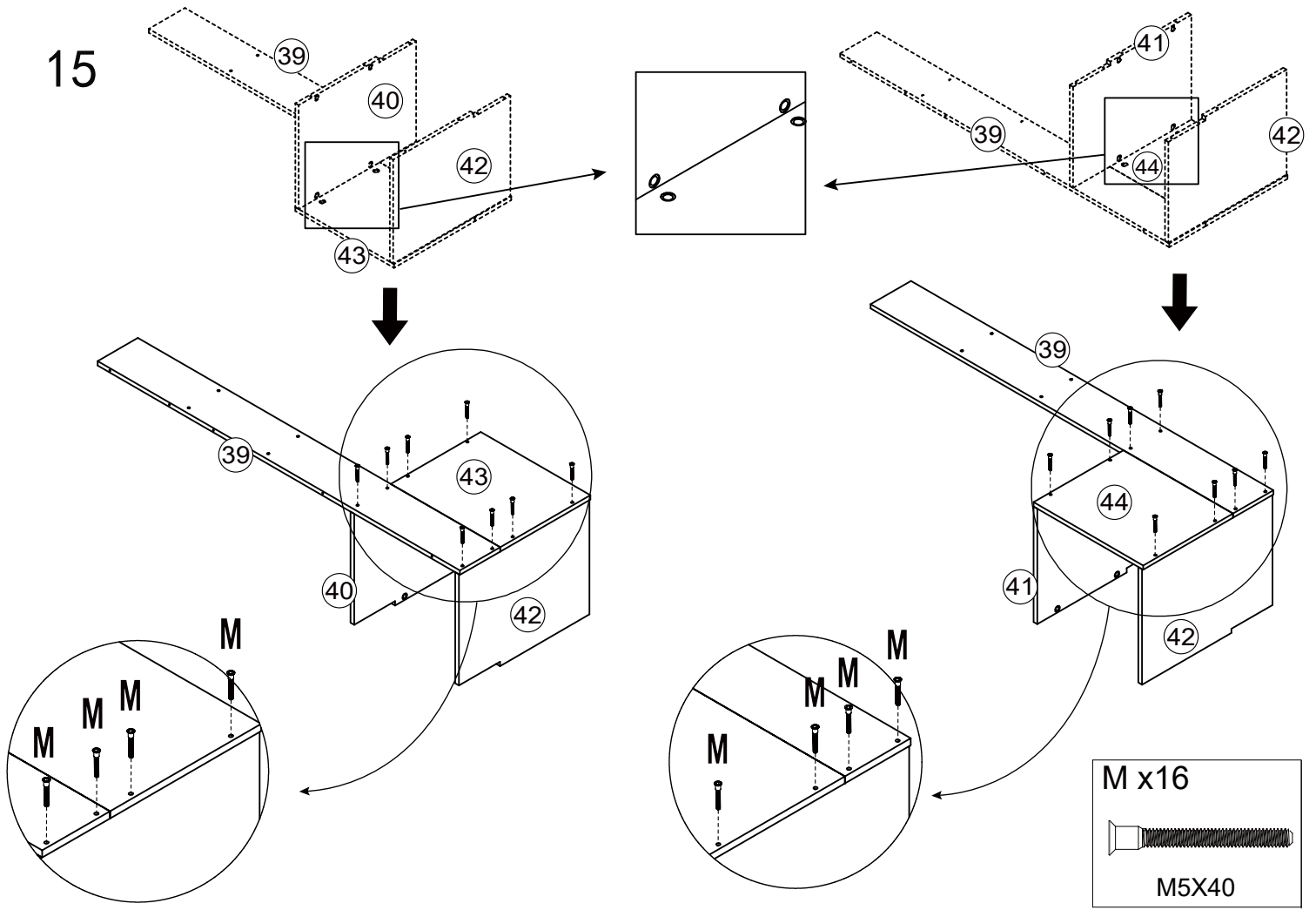

16

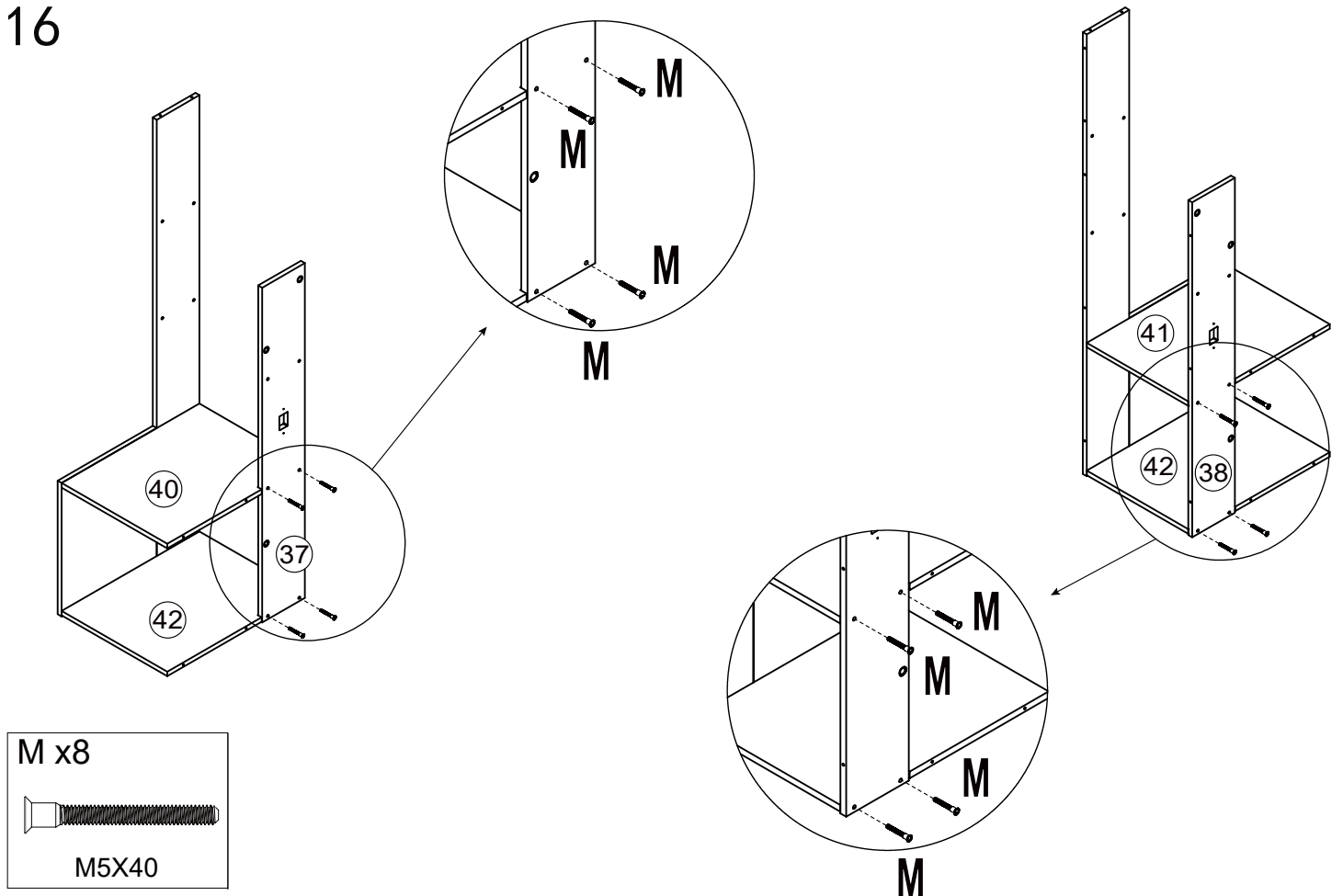

17

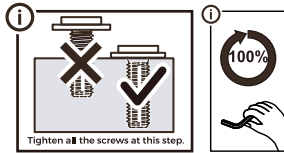
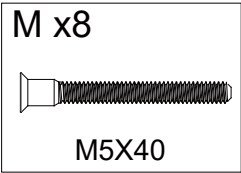
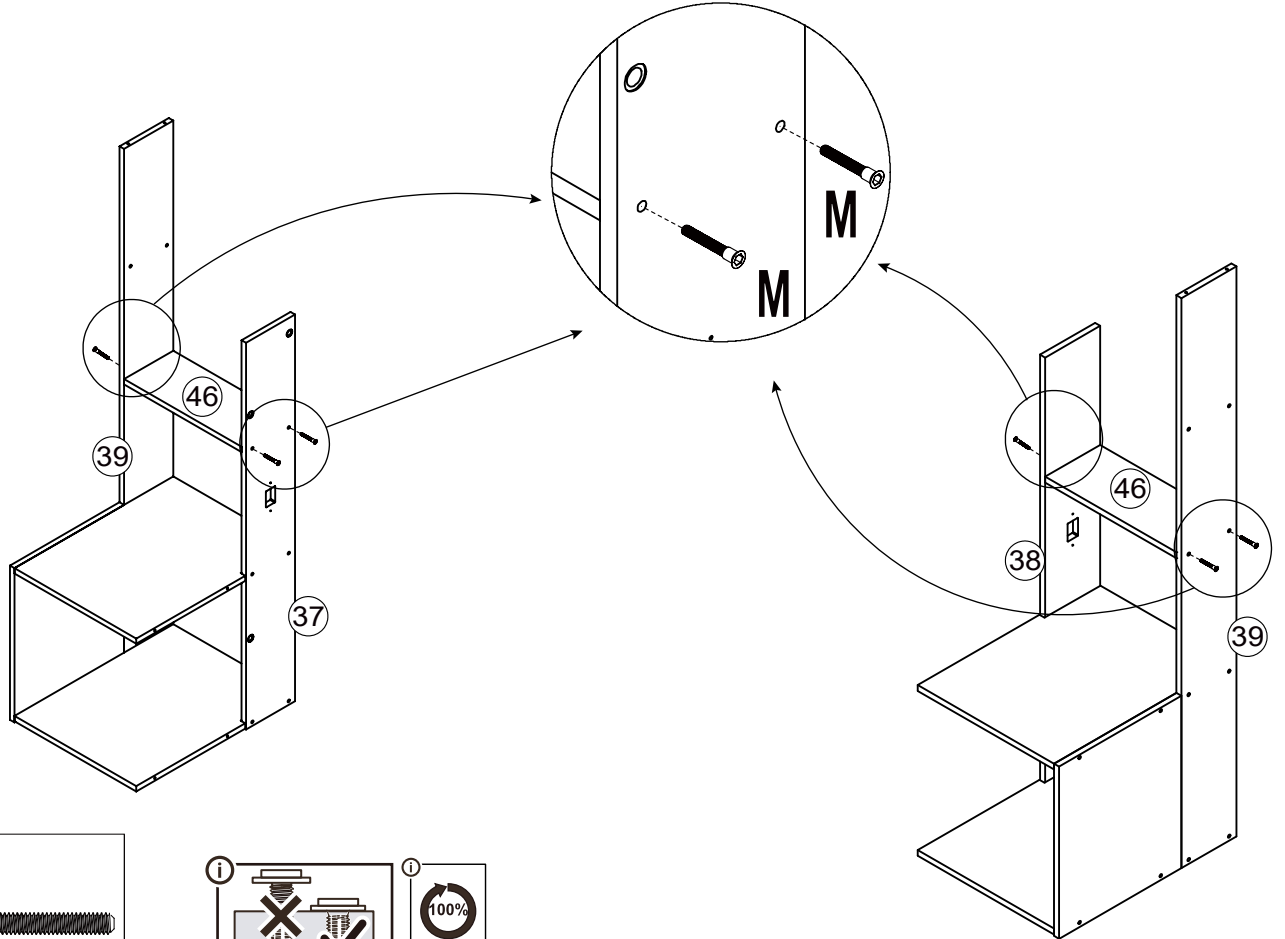

18

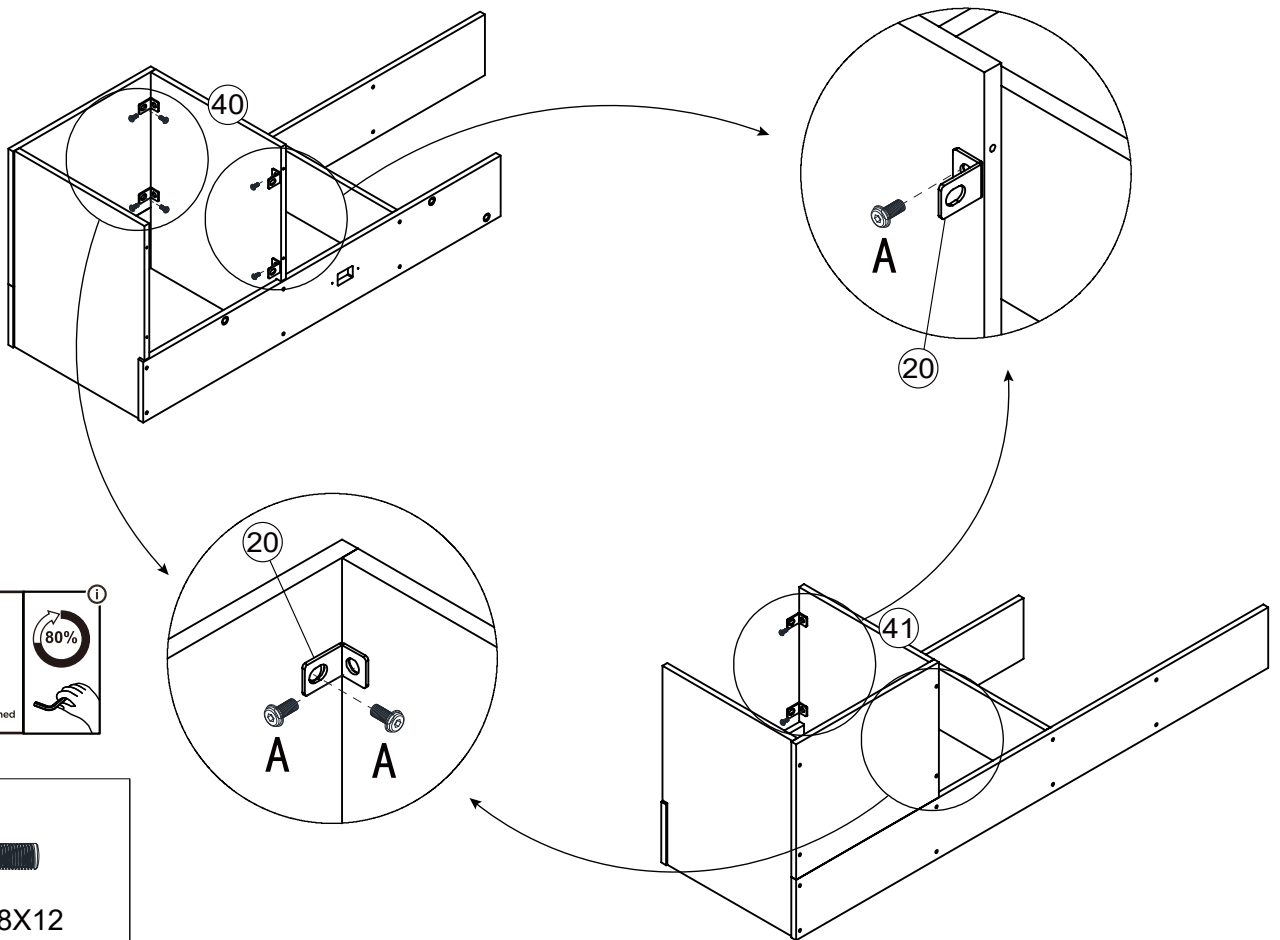

19

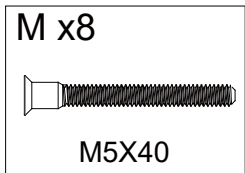
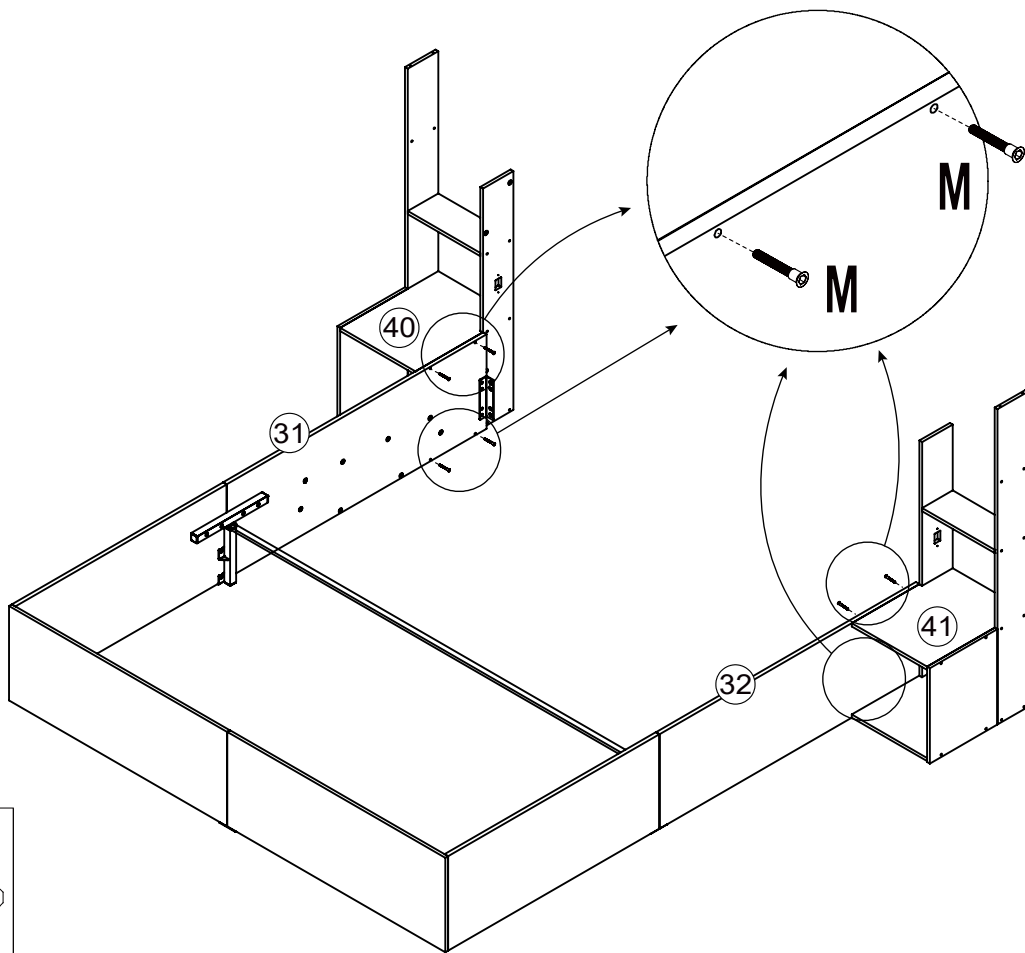

20

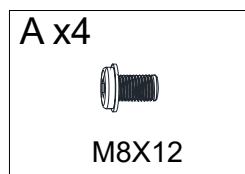
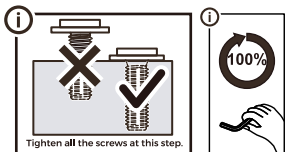
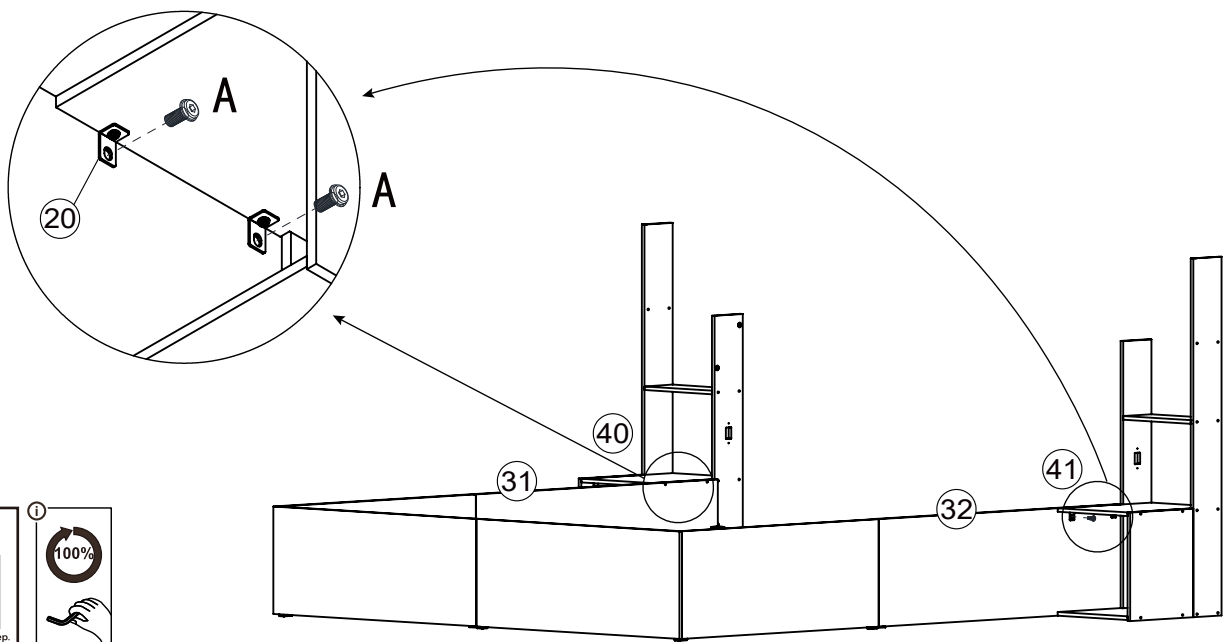

21

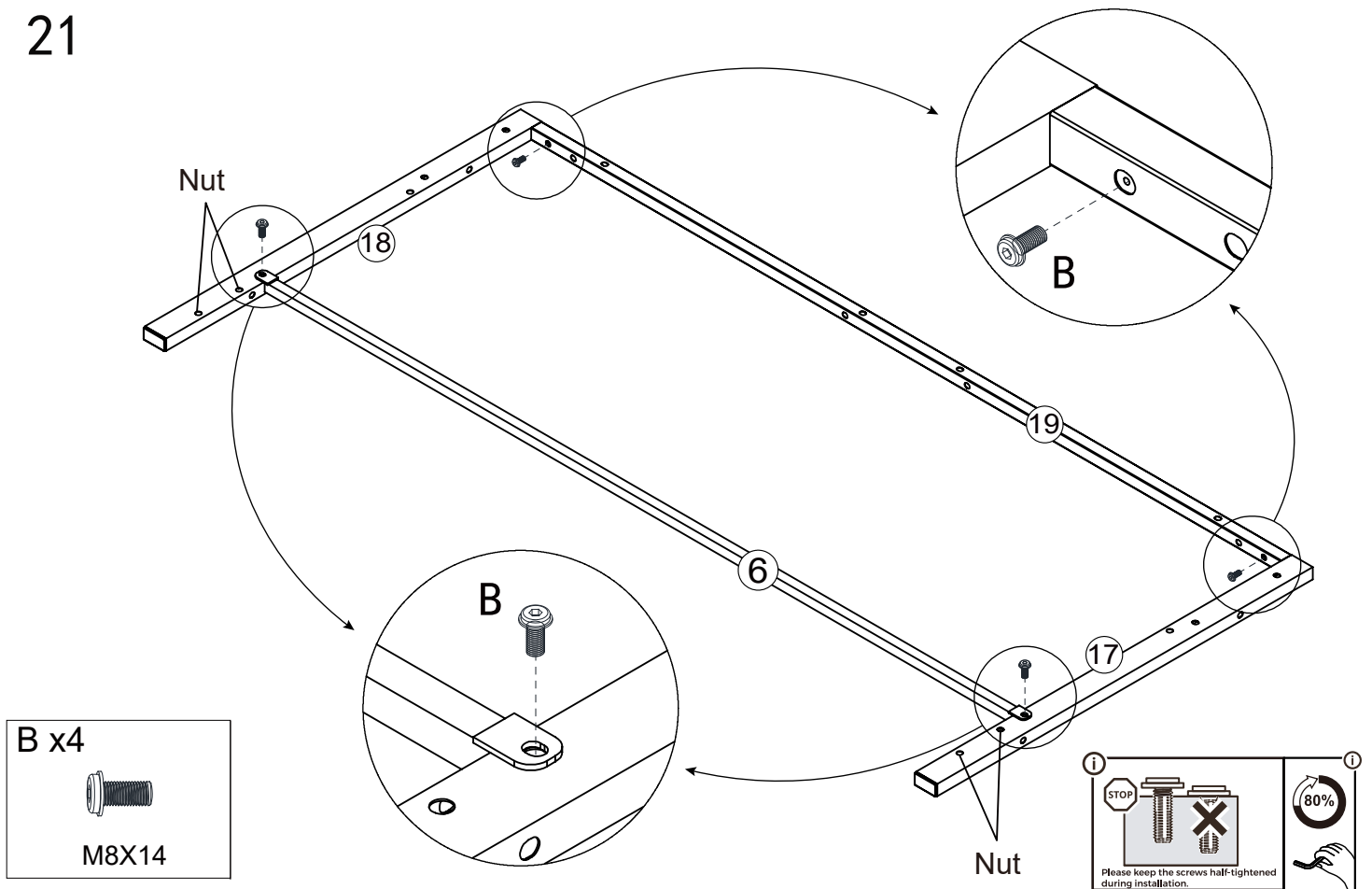

22

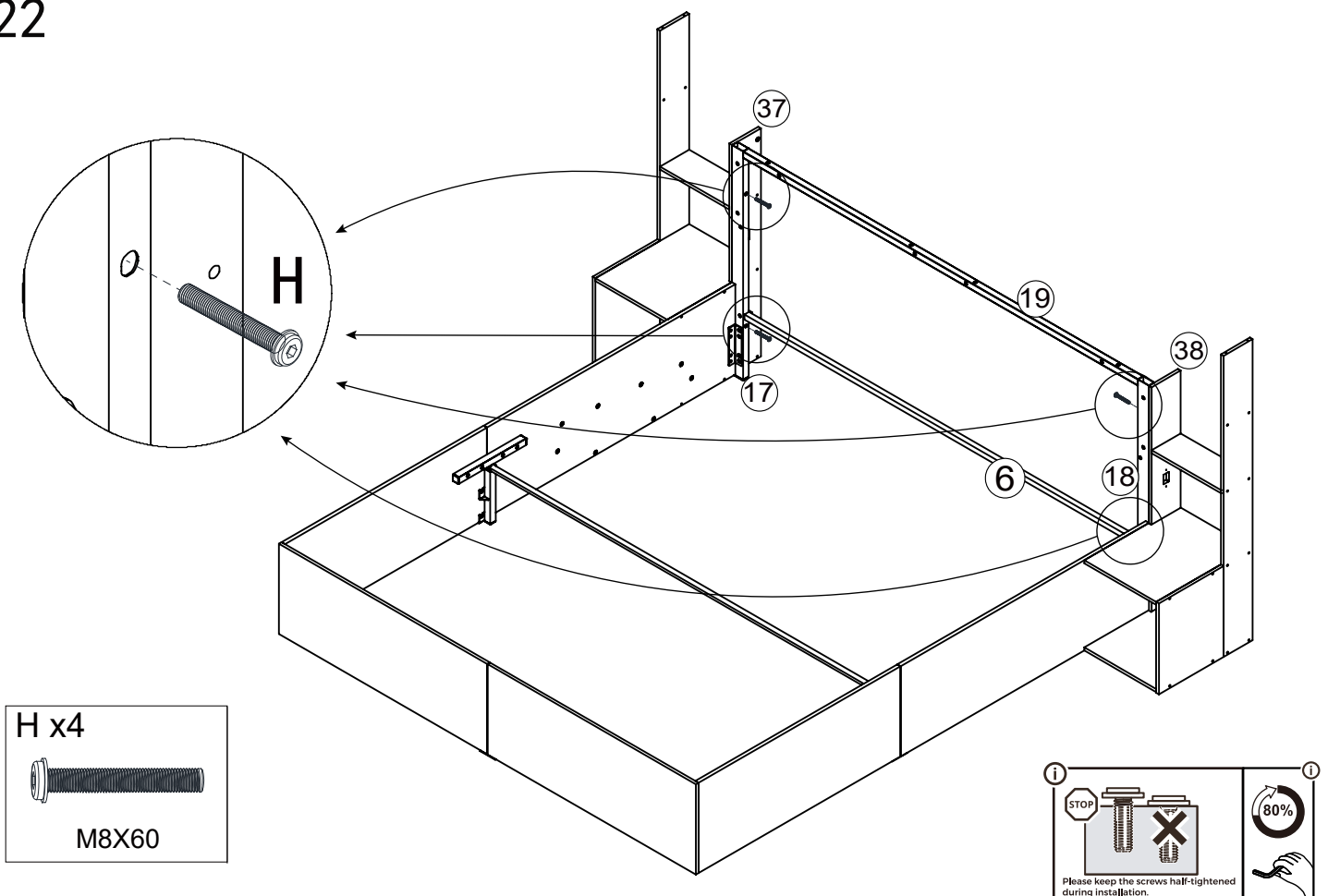

23

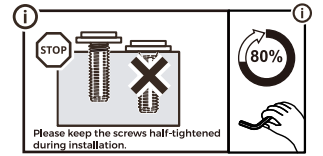
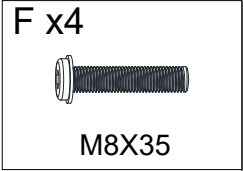
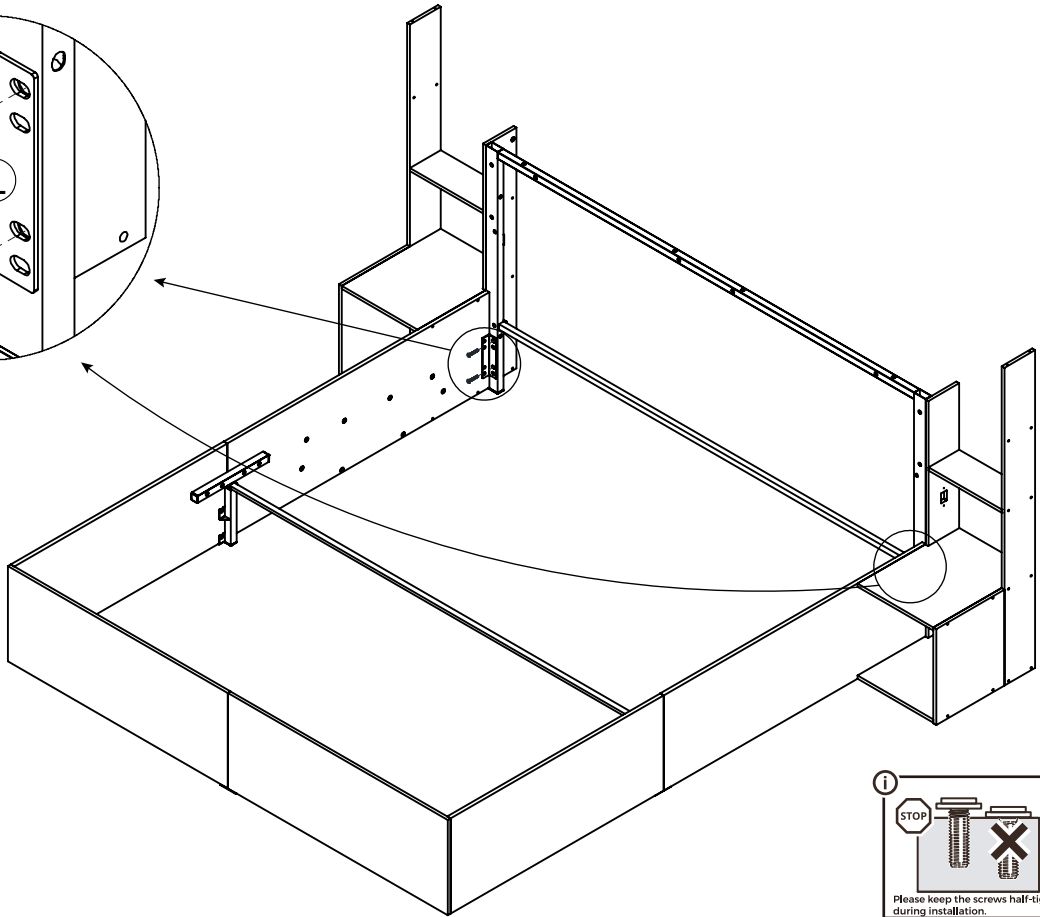
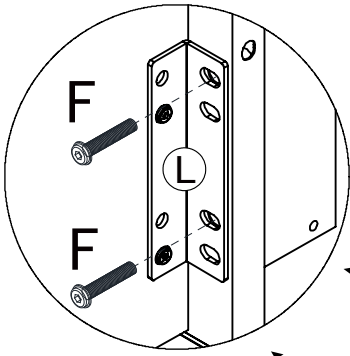

24

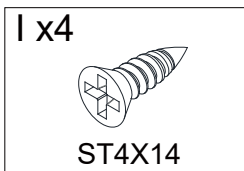
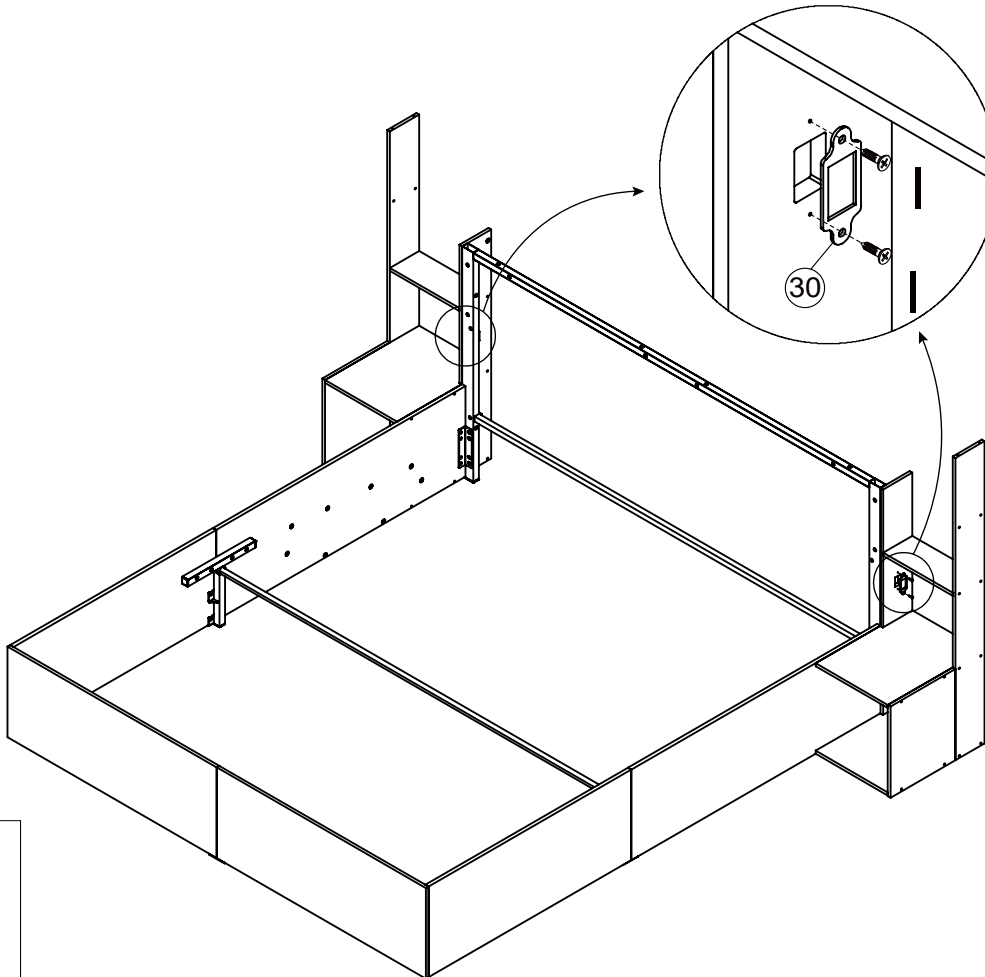
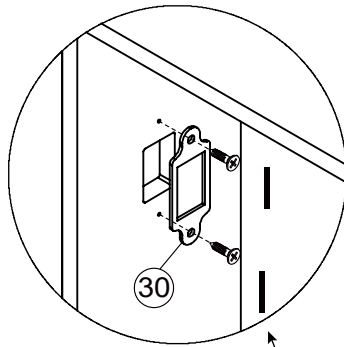

25

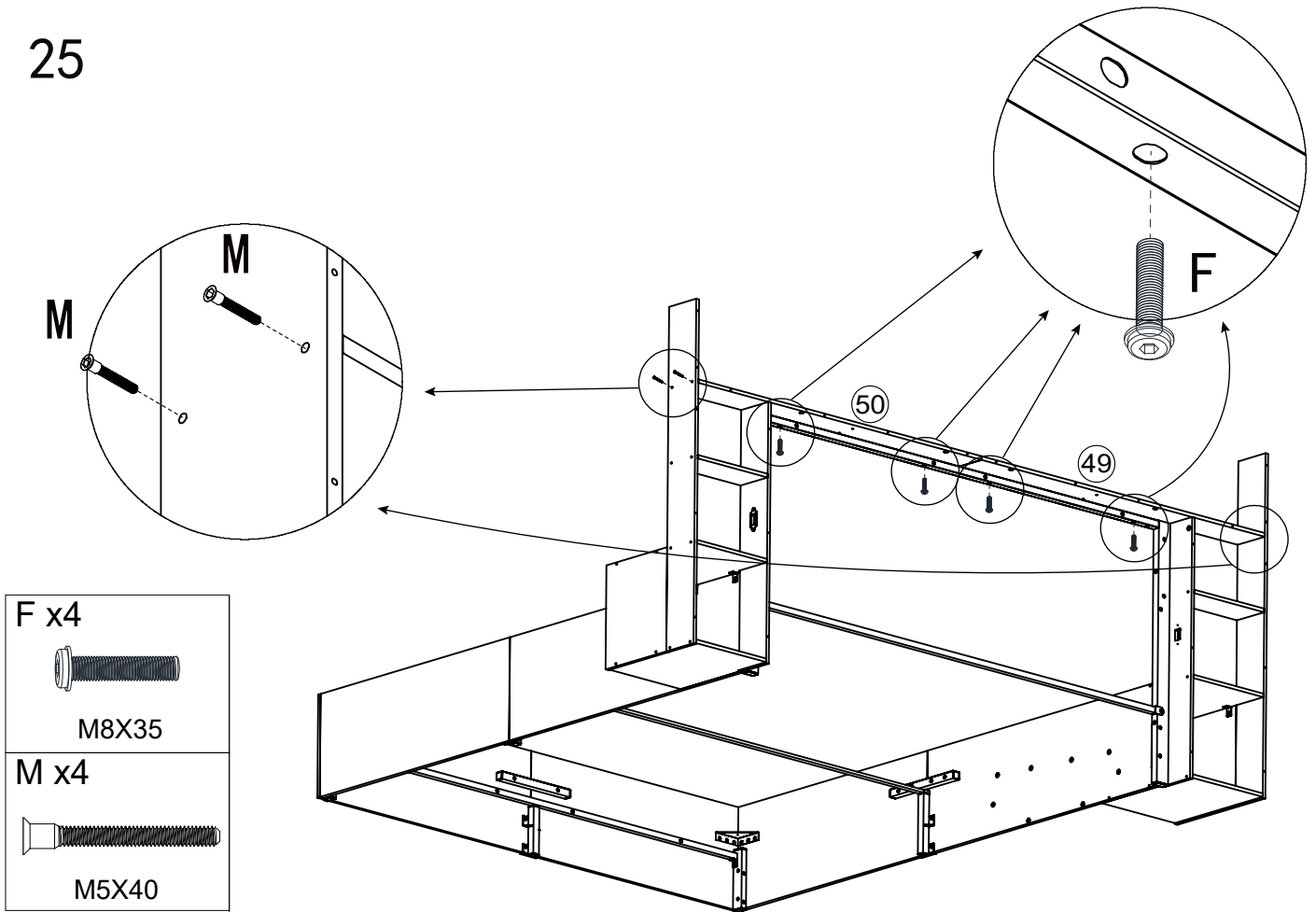

26

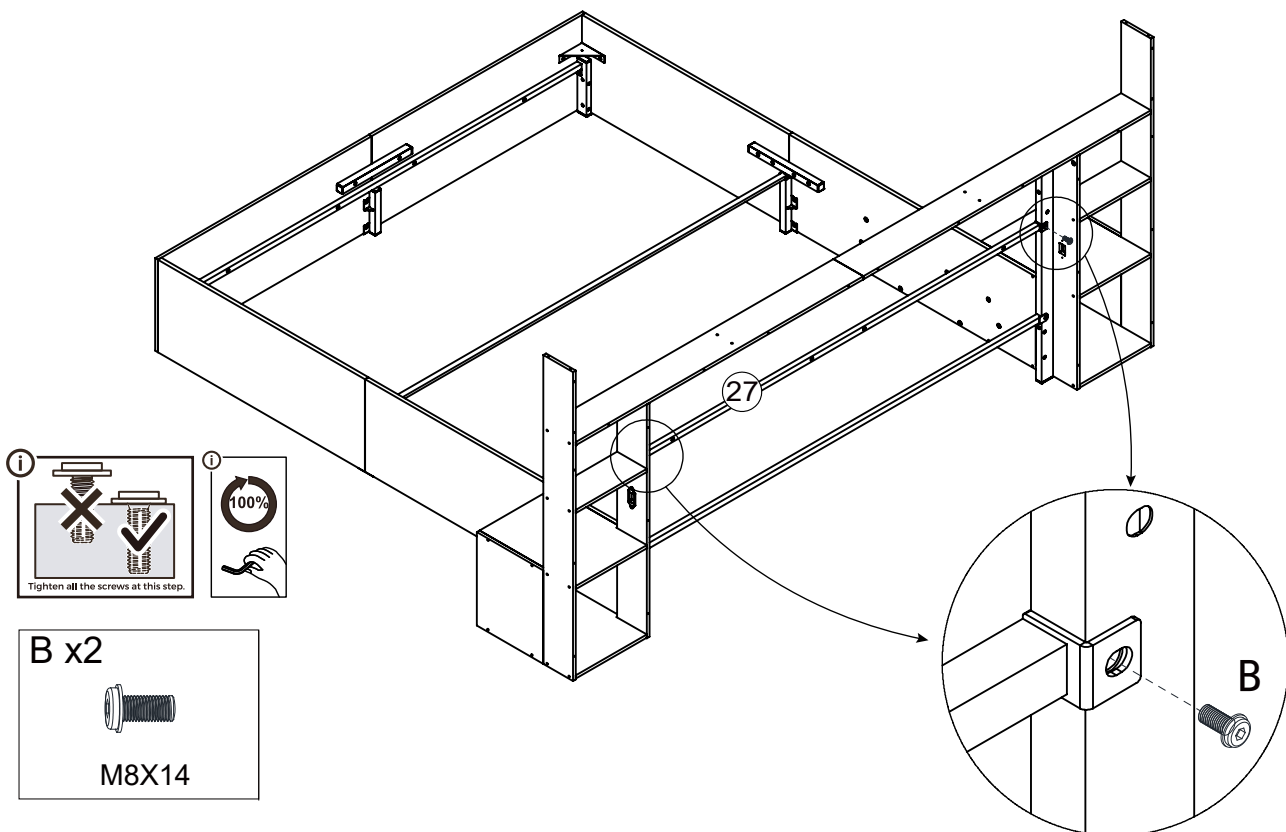

27

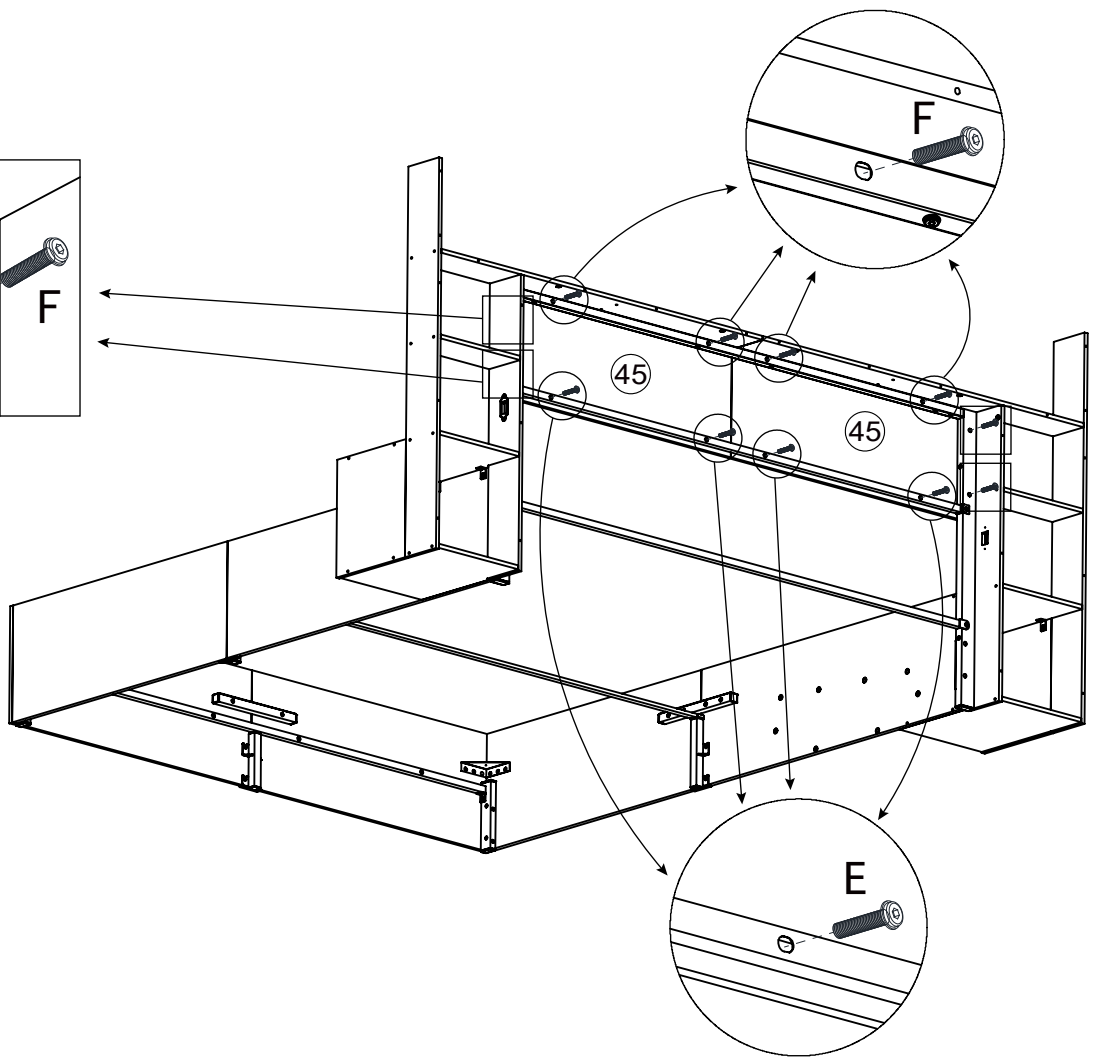
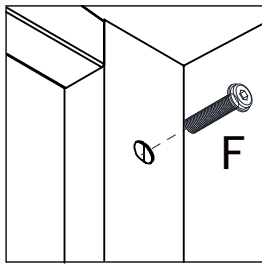

E x4



M8X30

F x8



M8X35

28

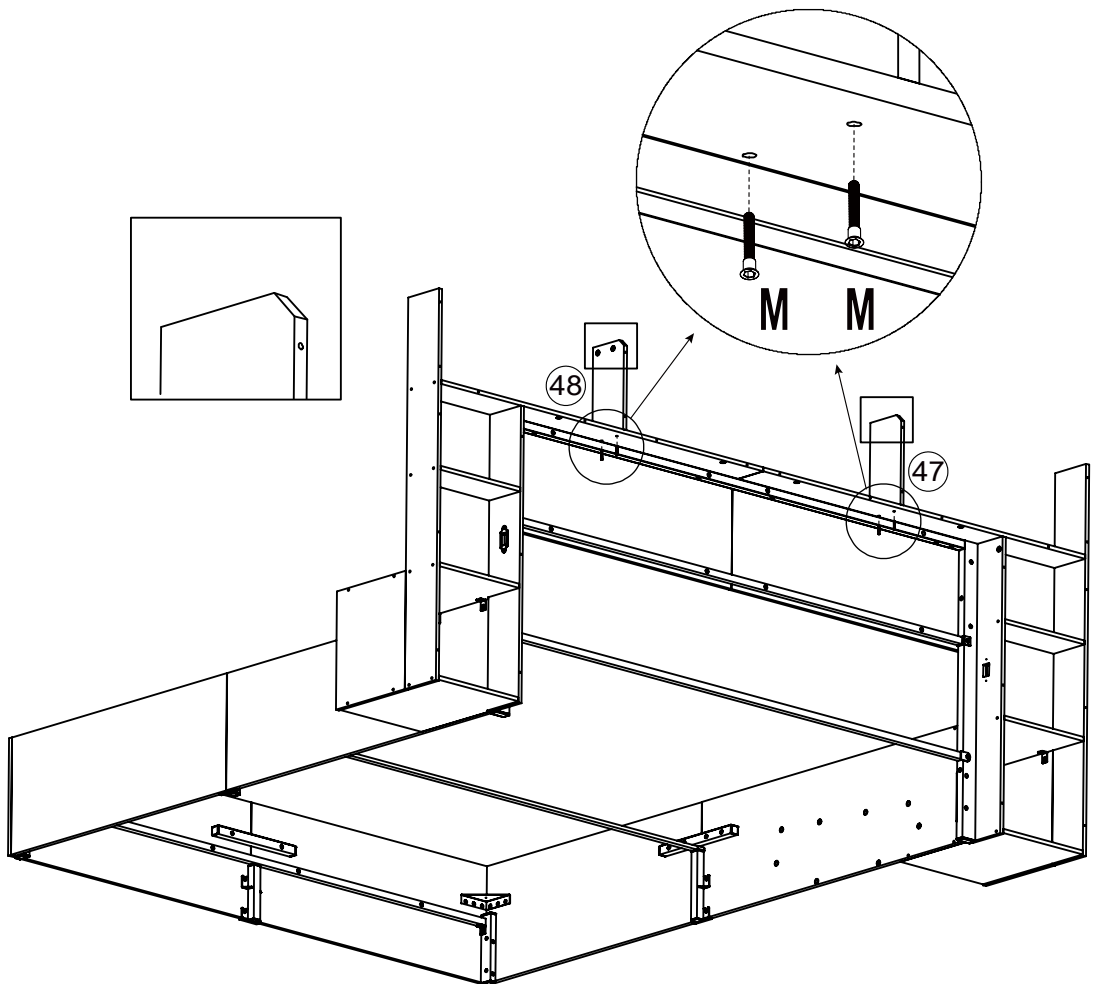
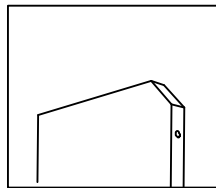
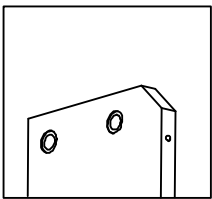

M x4



M5X40

29

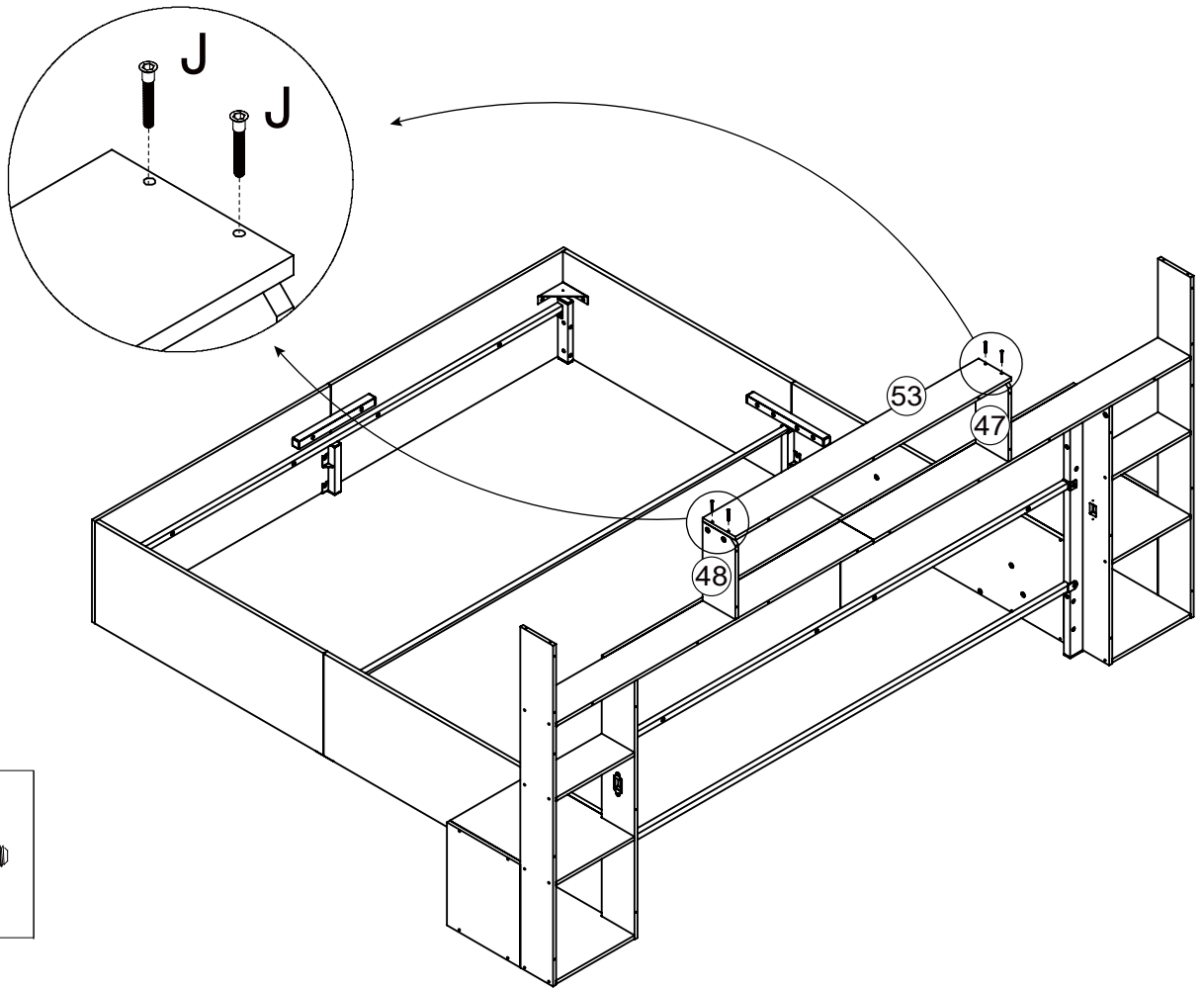

J x4



M5X30

30

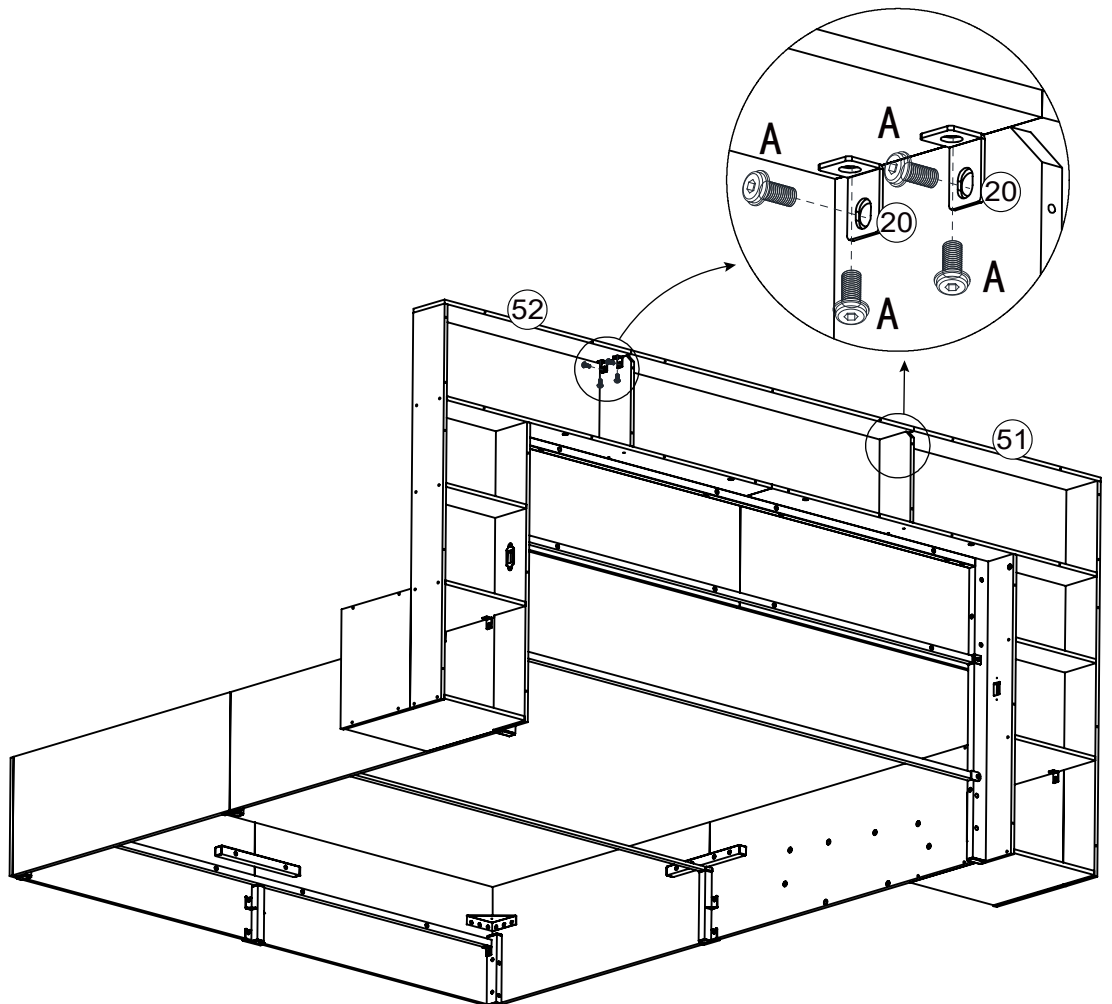

A x8



M8X12

31

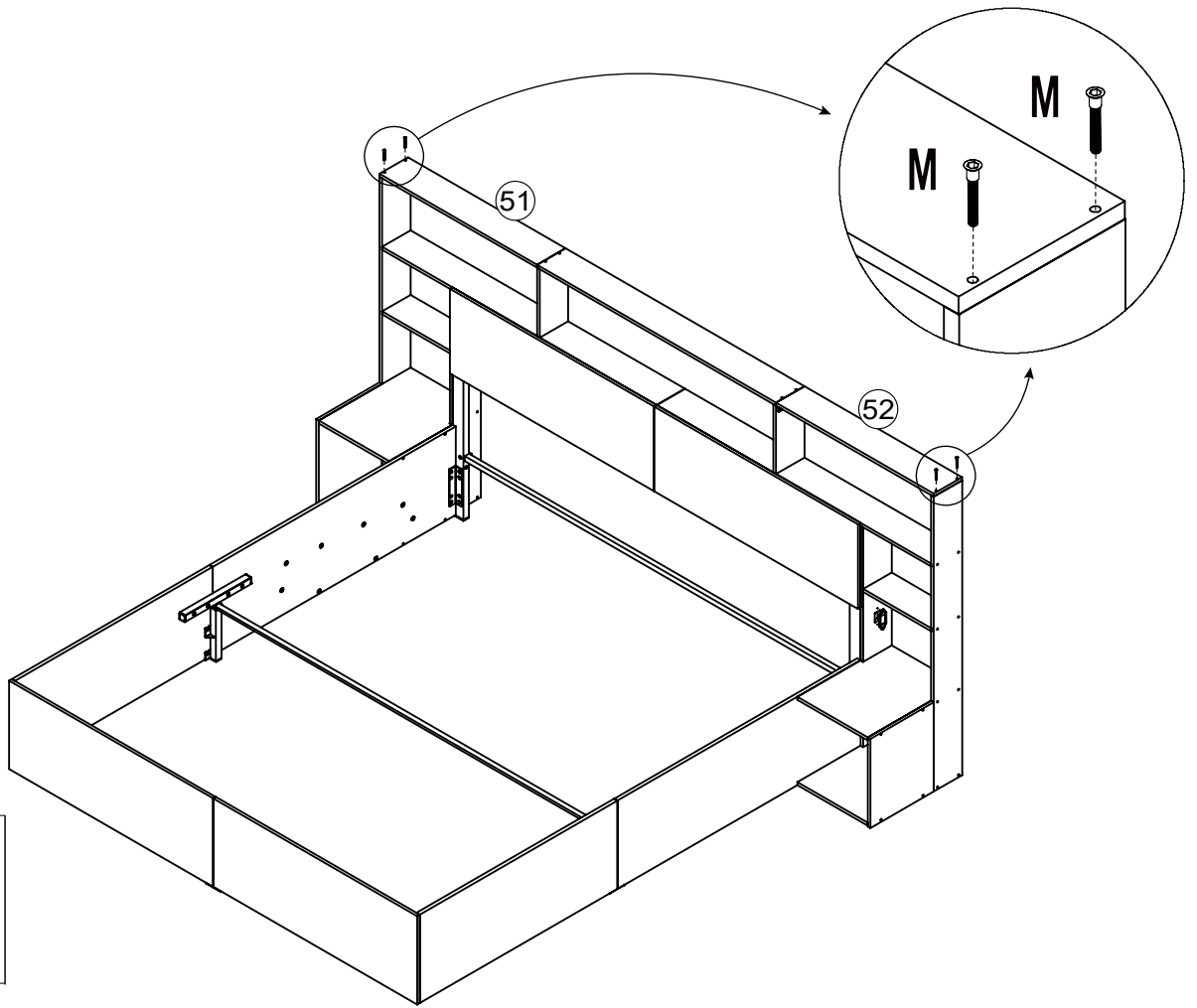

32

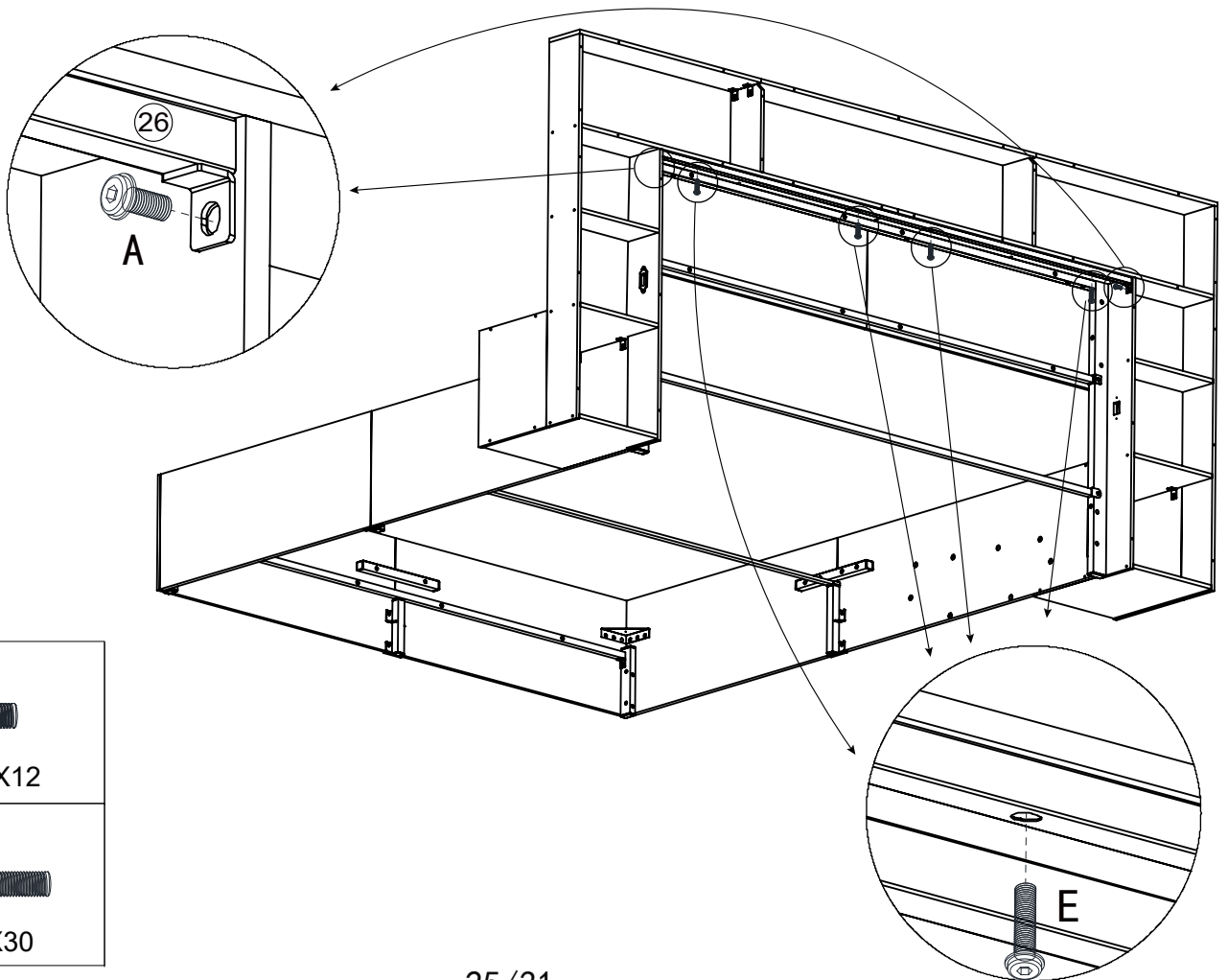

33

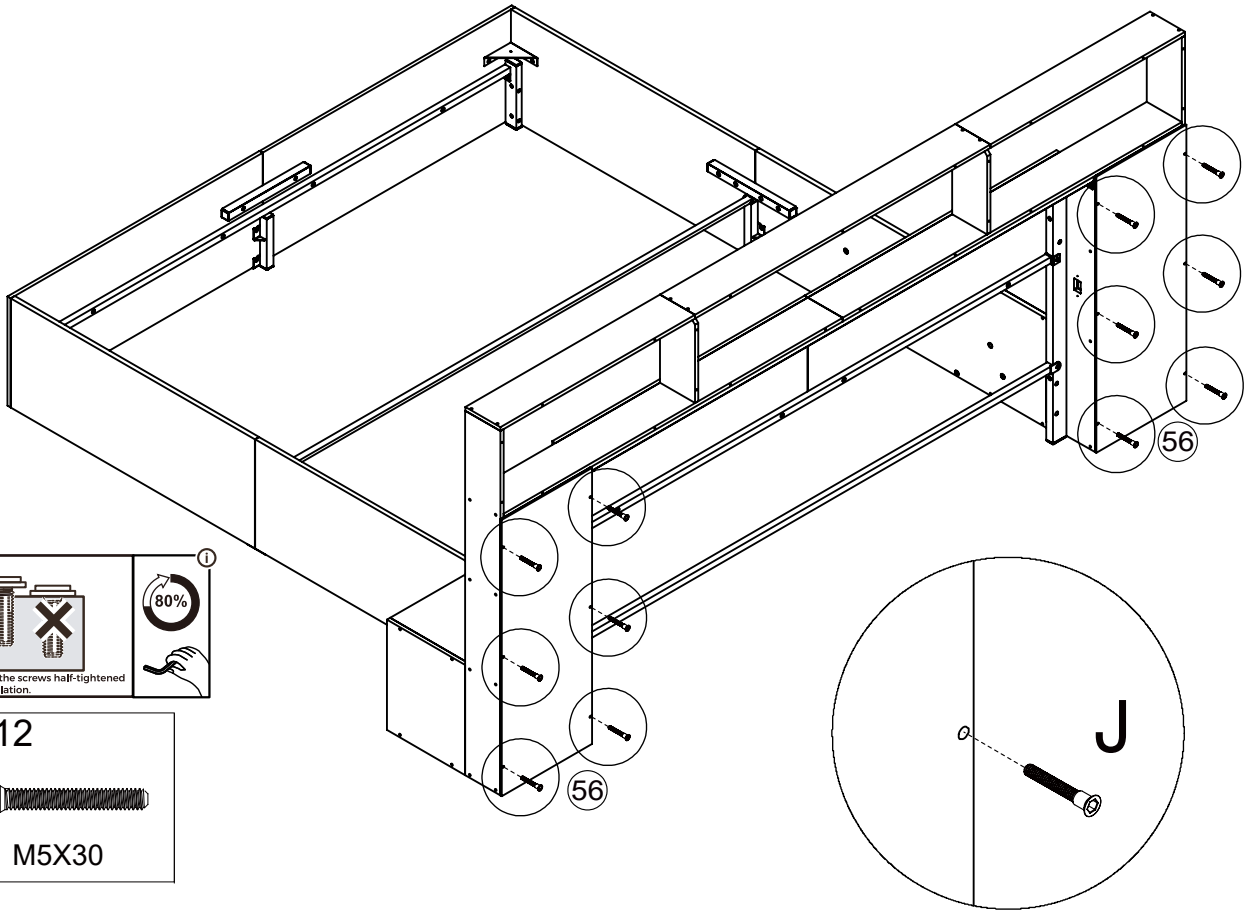

34

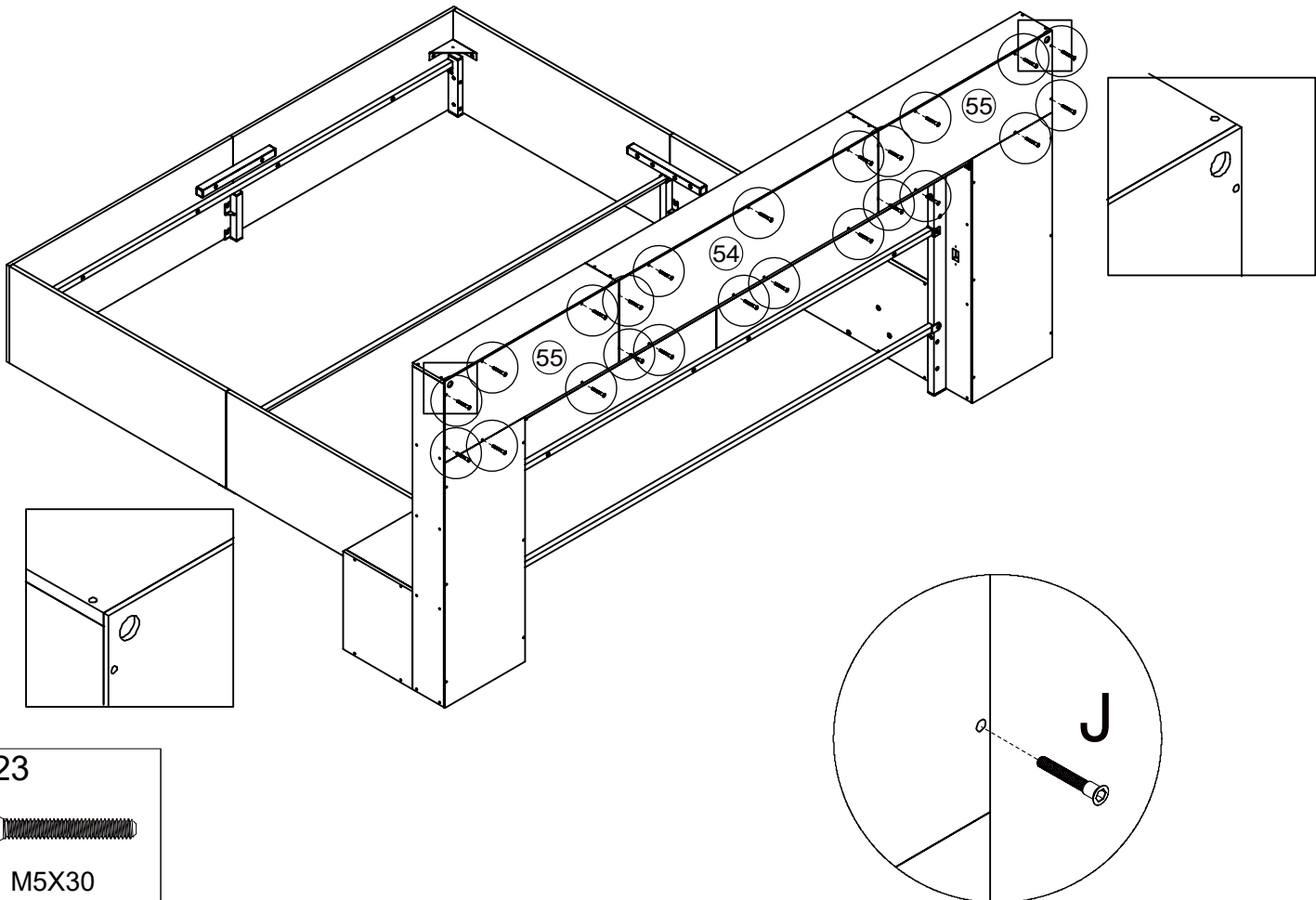

35

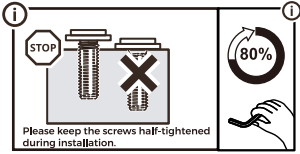
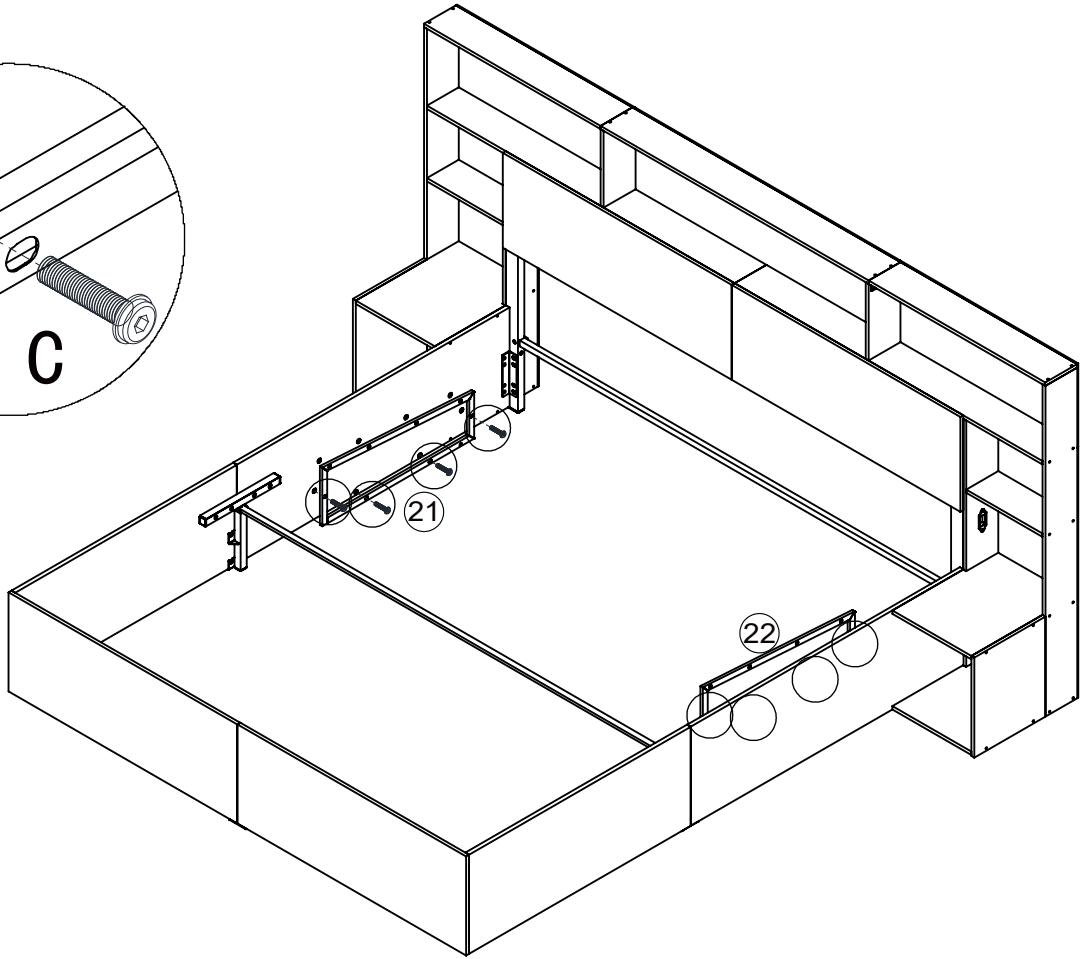
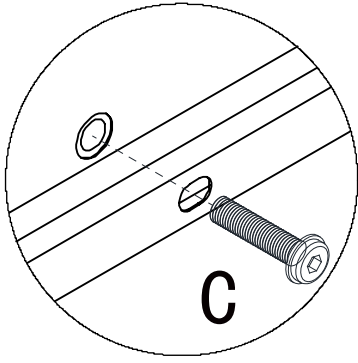

C x8



M8X20

36

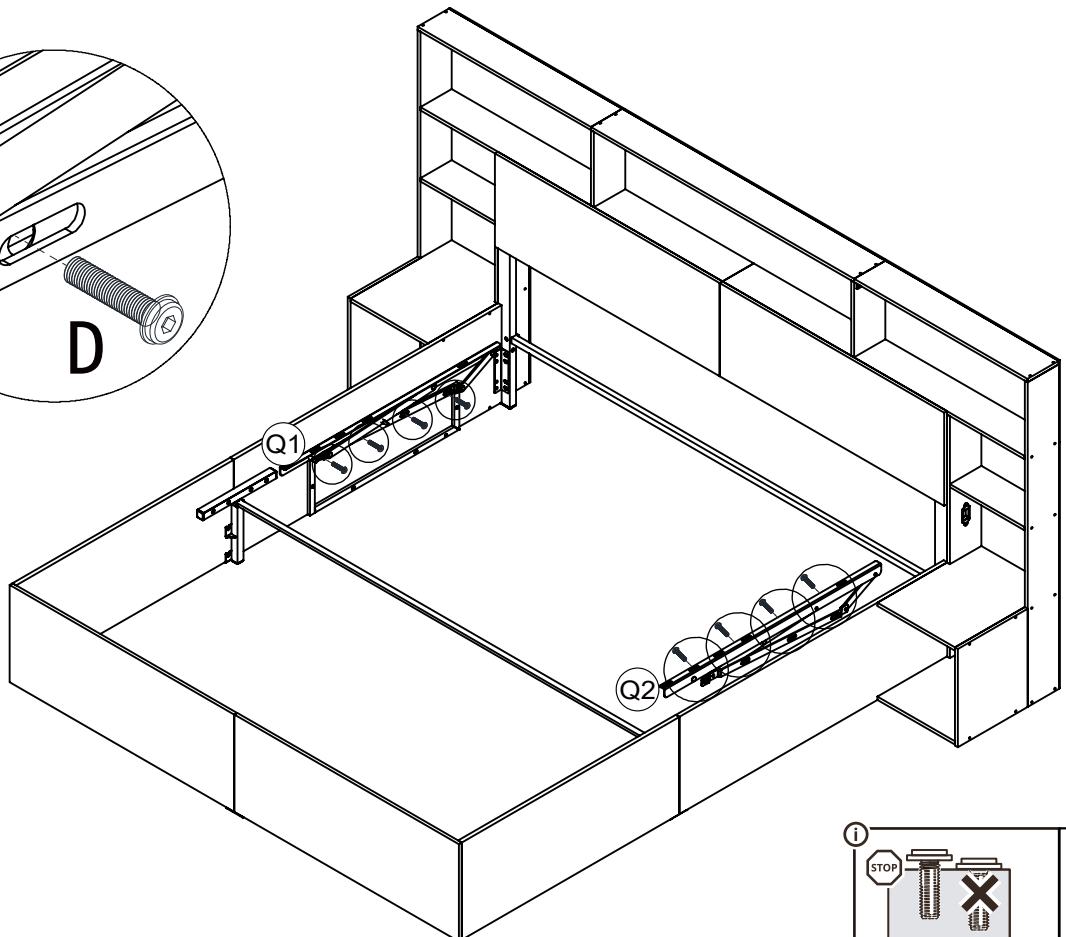
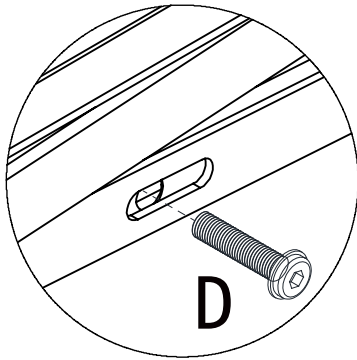

D x8



M8X25

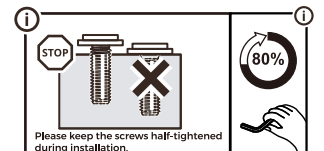

37

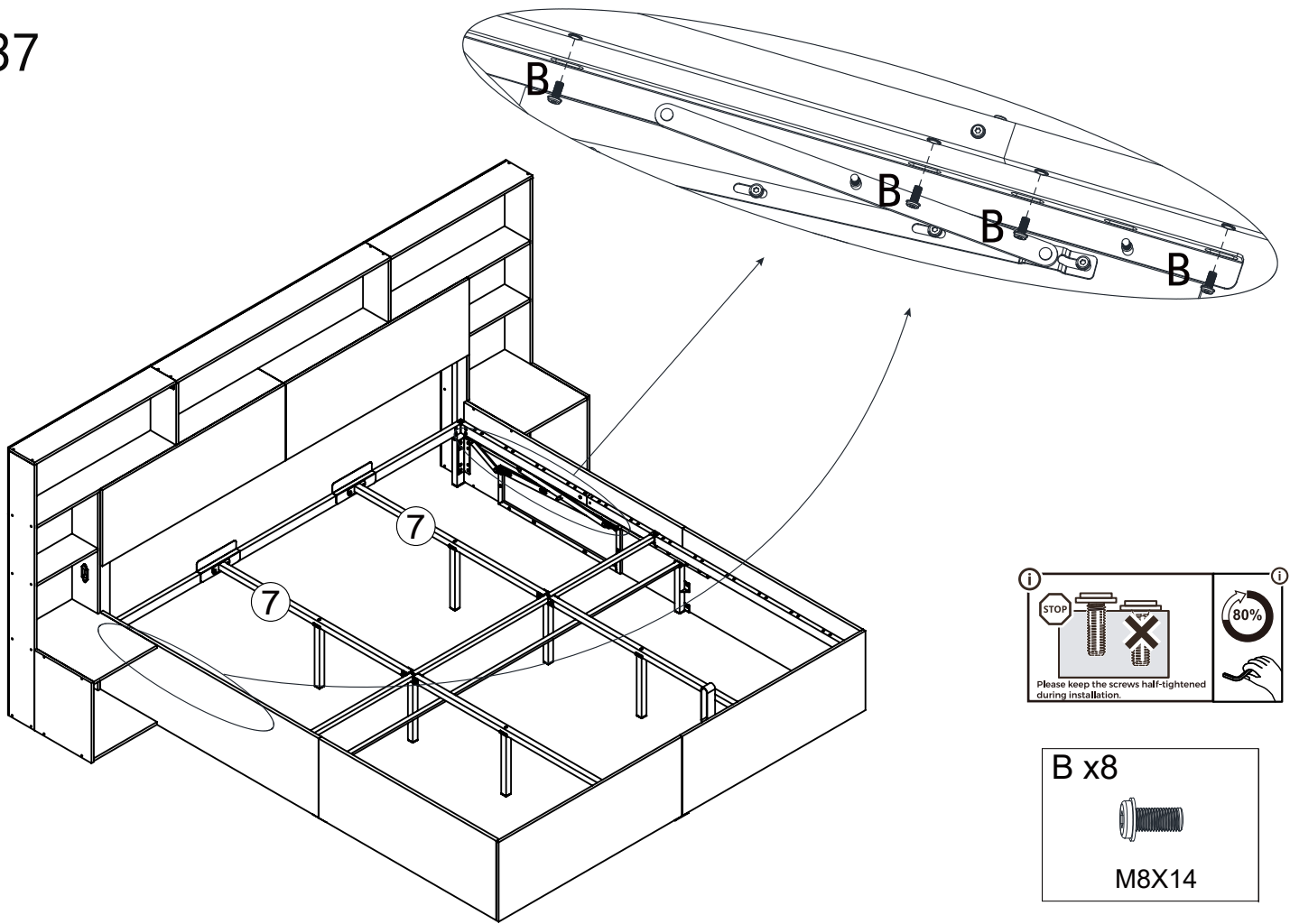

38

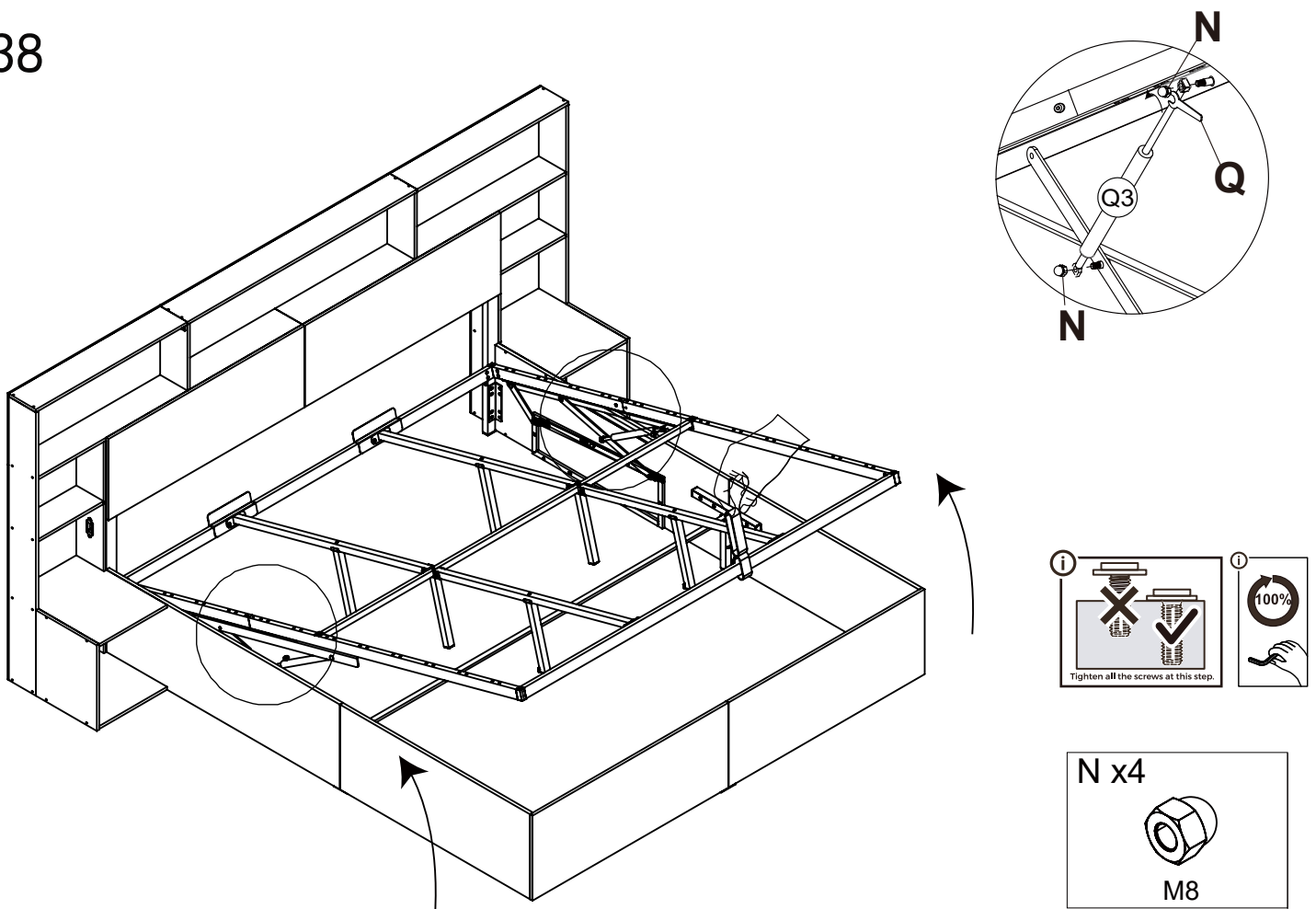

39

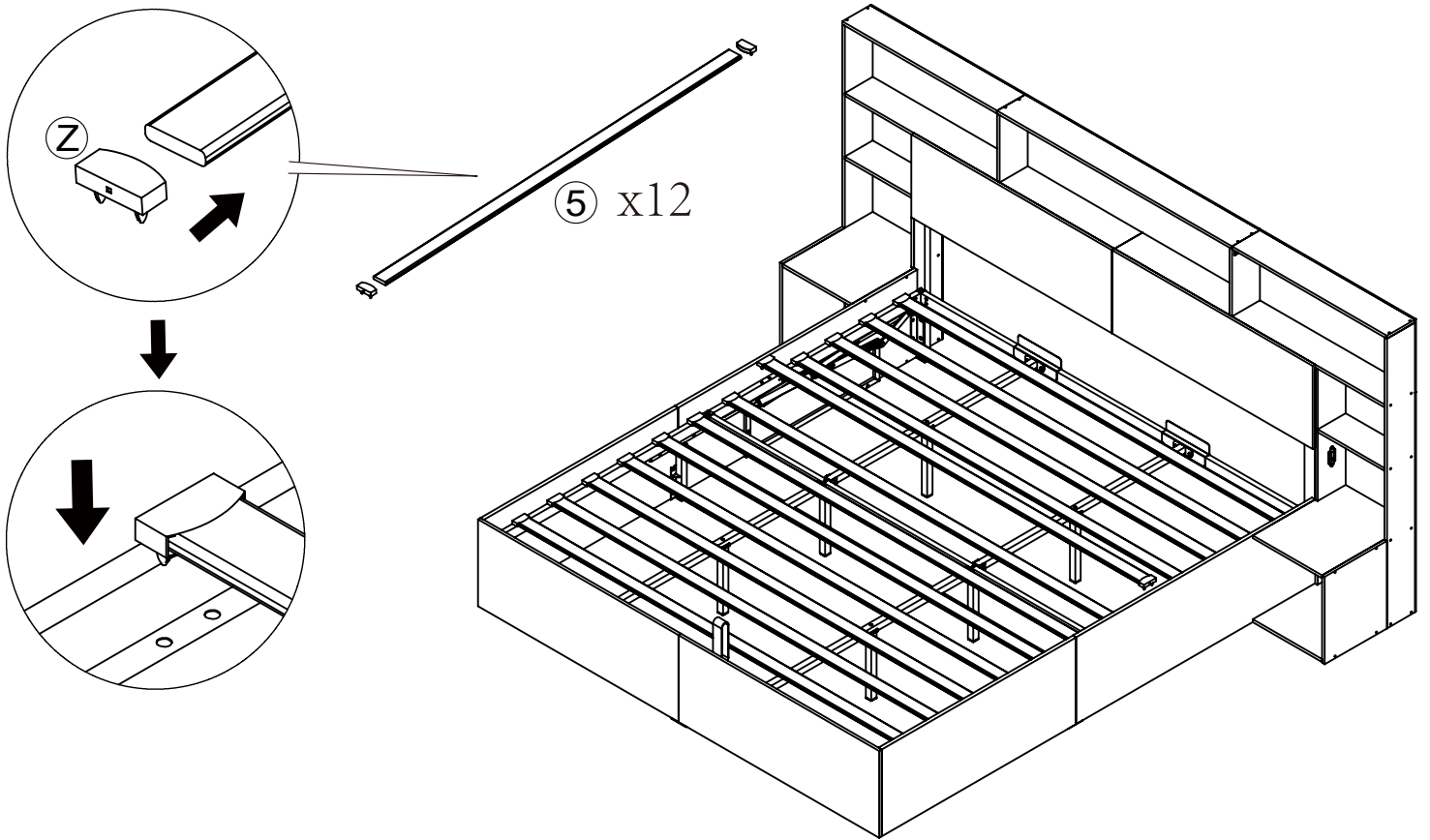

40

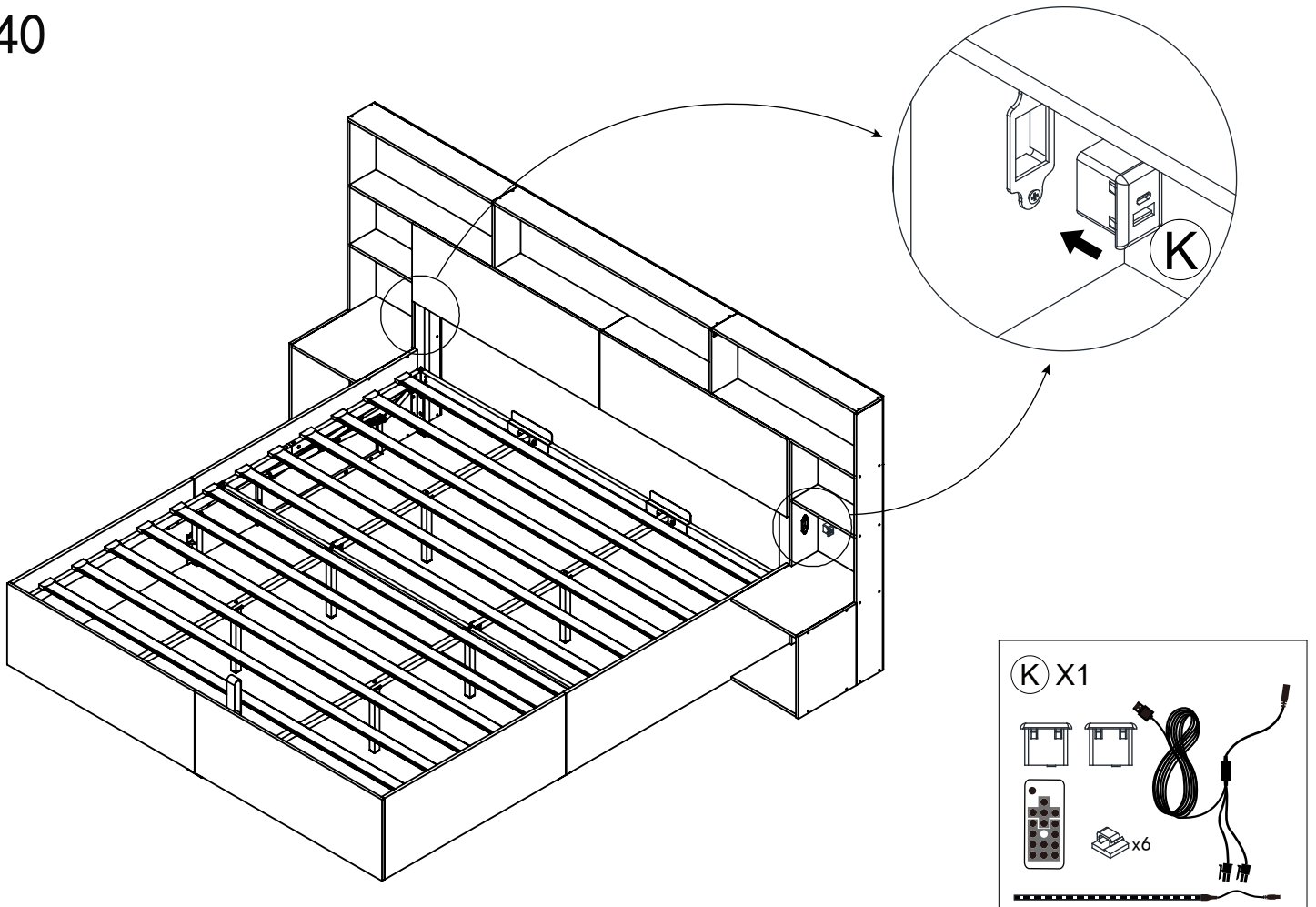

41

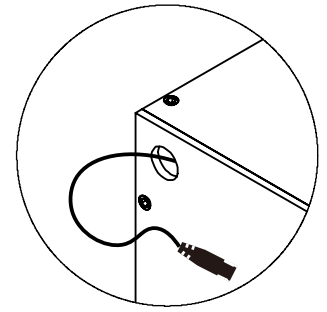
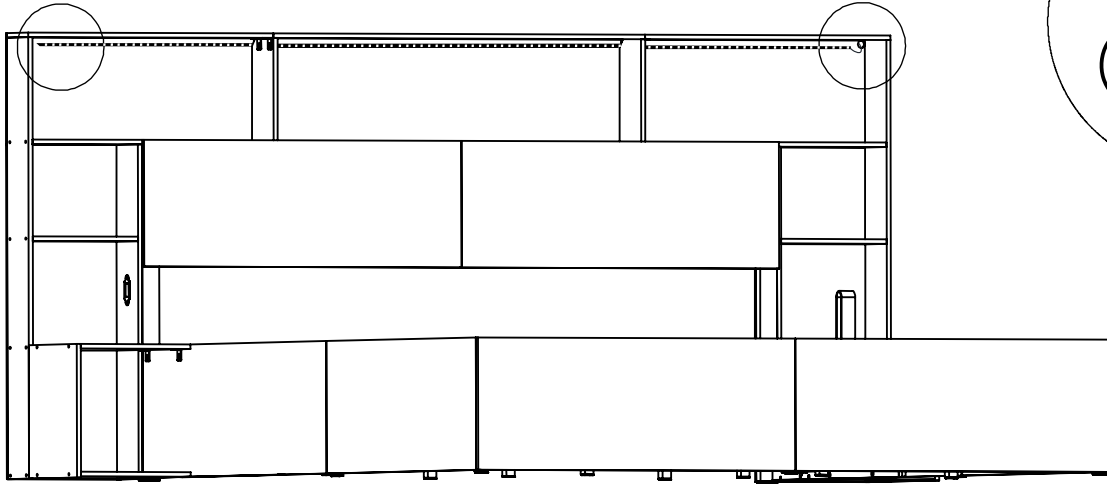

Tear the double-sided tape
 Zerrei das band
 D chirer la bande double face
 Strappamento del nastro adesivo
 Rasgar cinta doble cara

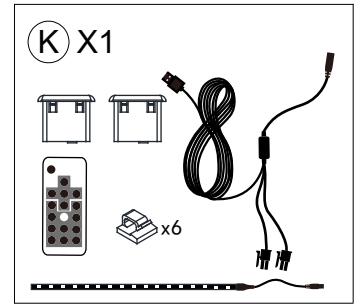
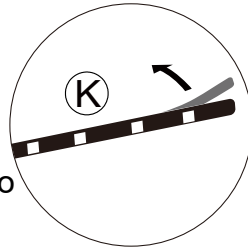

42

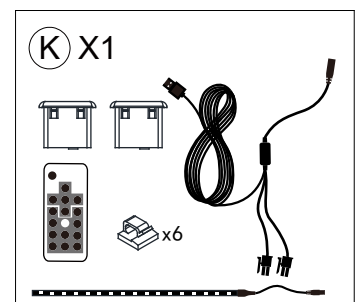
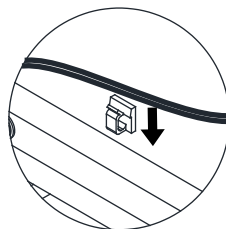
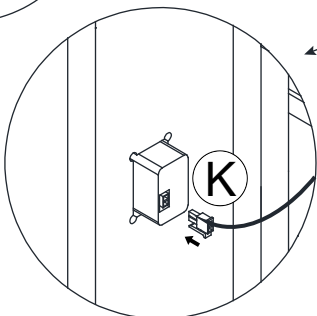
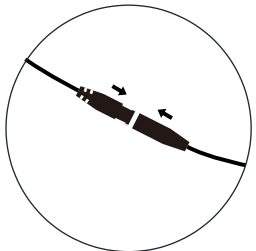
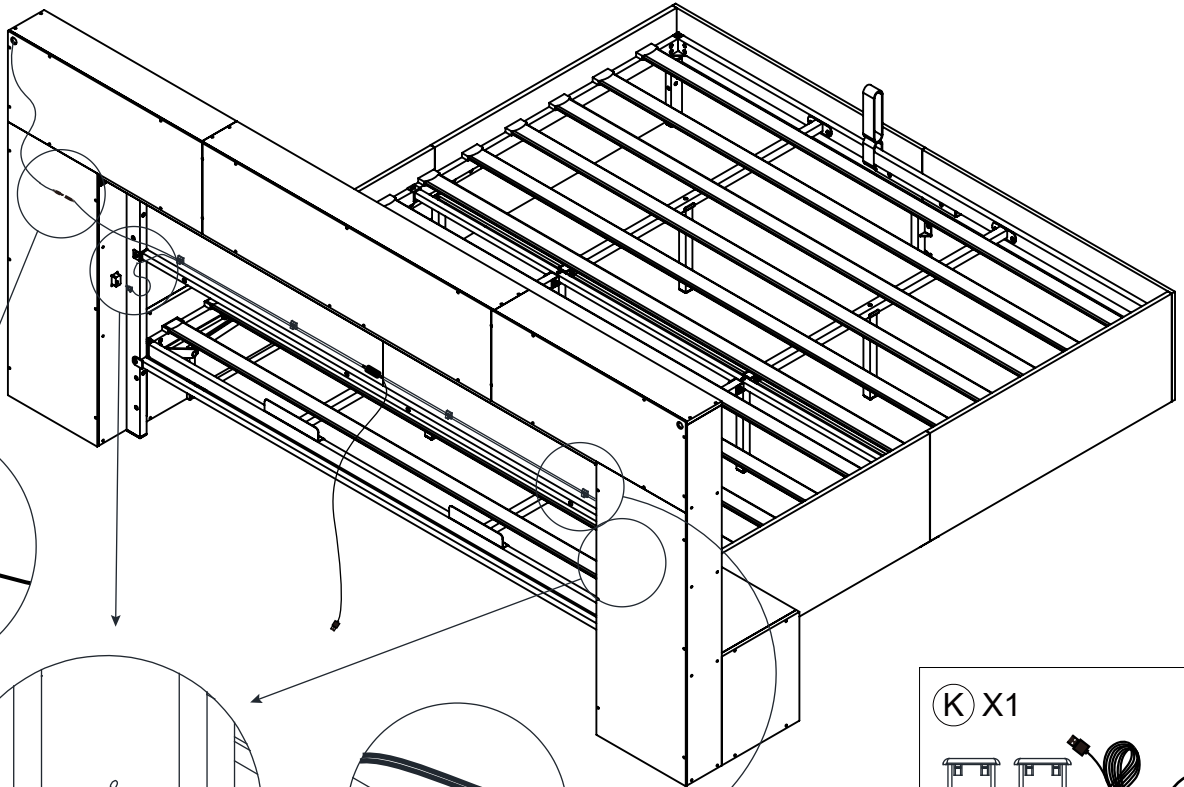



GB: Tighten all hardware
DE: Ziehen Sie alle Beschläge fest
FR: Serrez toutes les ferrures
IT: Stringere tutta la ferramenta
ES: Apriete toda la tornillería

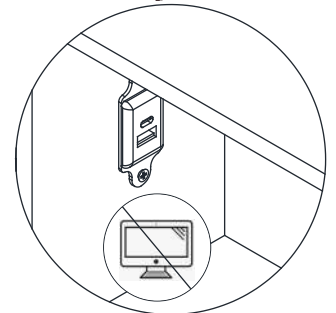
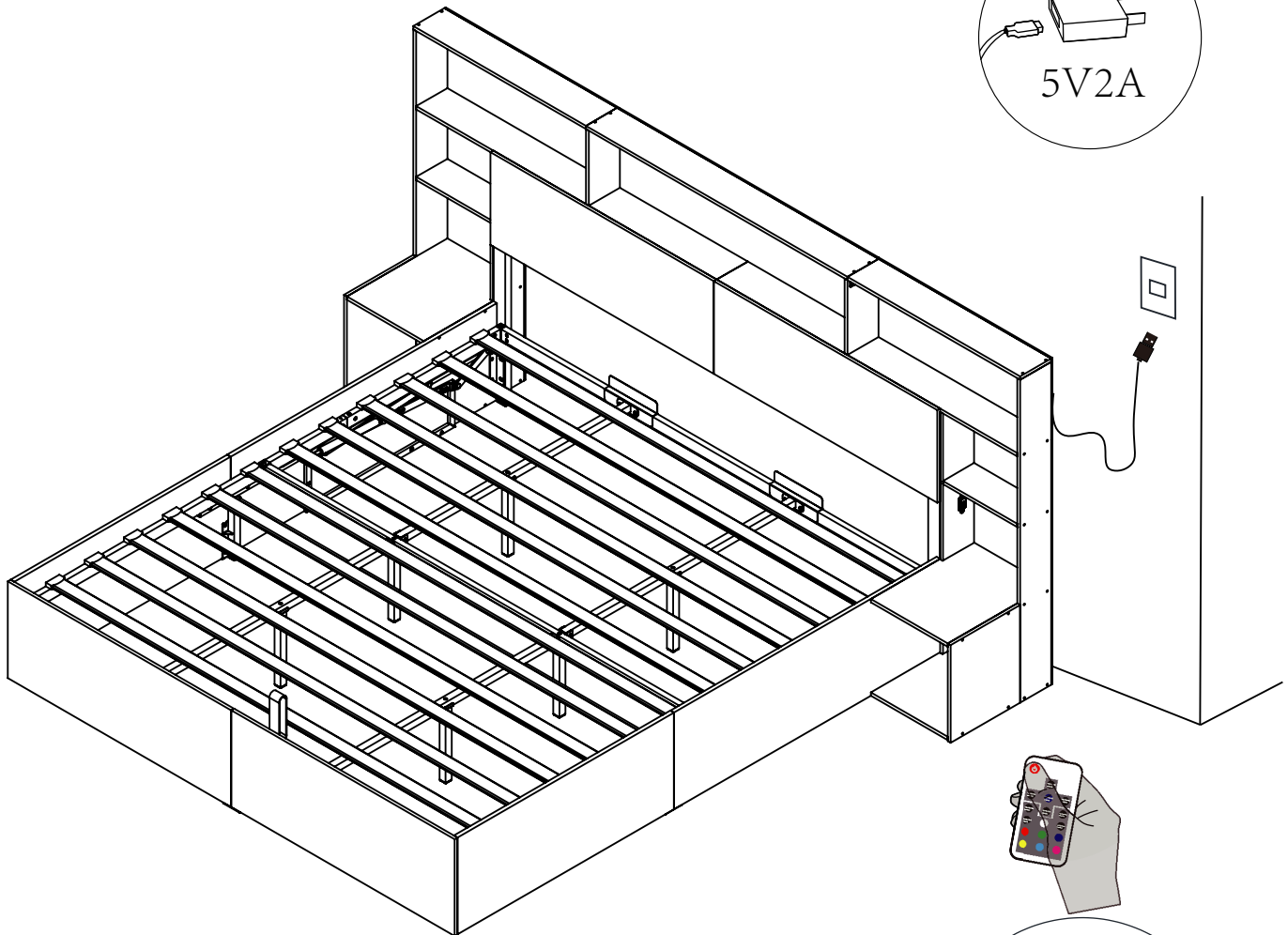
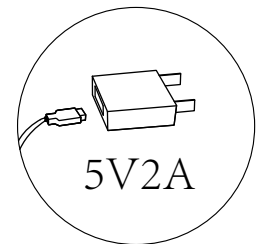

Installation Complete

GB – NOTE: The battery in the remote control requires you to purchase and install it yourself.
Model: CR2025 3.V

DE – HINWEIS: Die Batterie in der Fernbedienung müssen Sie selbst kaufen und installieren
Modell: CR2025 3.V

FR – REMARQUE : la pile de la télécommande doit être achetée et installée par vos soins.
Modèle : CR2025 3.V

IT – NOTA: la batteria del telecomando deve essere acquistata e installata autonomamente.
Modello: CR2025 3.V

ES – NOTA: La pila del mando a distancia debe comprarla e instalarla usted mismo
Modelo CR2025 3.V



EN:Battery Safety Instructions

1. Do not dispose of used button batteries or remote controls in household trash. To protect the environment and prevent hazardous leakage, please follow these guidelines:
2. Remove button batteries after use and take them to a local battery recycling point or hazardous waste collection site.
3. Do not burn or dismantle the batteries to avoid explosion or toxic release.
4. If the remote control is no longer in use, please deliver it to a certified electronics recycling facility to promote resource reuse.
5. Keep out of reach of children to prevent accidental ingestion or injury.
6. This product does not include batteries; please purchase them separately. The compatible button cell model for the remote control is CR2025.3V
7. If the light strip is not working, please try replacing the battery first. If the issue persists, contact the seller for assistance.
8. **Keep the remote control away from children — keep it away from children!** If the battery is accidentally swallowed, seek medical attention immediately.

DE: Batteriesicherheitshinweise

1. Entsorgen Sie gebrauchte Knopfzellen oder Fernbedienungen nicht im Hausmüll. Um die Umwelt zu schützen und gefährliche Leckagen zu vermeiden, beachten Sie bitte die folgenden Hinweise:
2. Entfernen Sie die Knopfzelle nach dem Gebrauch und bringen Sie sie zu einer örtlichen Batteriesammelstelle oder einem Sondermüllentsorgungszentrum.
3. Batterien nicht verbrennen oder zerlegen, um Explosionen oder die Freisetzung giftiger Stoffe zu vermeiden.
4. Wenn die Fernbedienung nicht mehr verwendet wird, bringen Sie sie zu einer zertifizierten Elektronik-Recyclingstelle, um eine Wiederverwertung zu ermöglichen.
5. Außerhalb der Reichweite von Kindern aufbewahren, um versehentliches Verschlucken oder Verletzungen zu verhindern.
6. Dieses Produkt enthält keine Batterien. Bitte kaufen Sie diese separat. Das kompatible Knopfzellenmodell für die Fernbedienung ist CR2025.3V
7. Wenn der Lichtstreifen nicht funktioniert, versuchen Sie zunächst, die Batterie zu wechseln. Besteht das Problem weiterhin, kontaktieren Sie bitte den Verkäufer.
8. **Halten Sie die Fernbedienung unbedingt von Kindern fern — unbedingt fernhalten!** Wird die Batterie versehentlich verschluckt, suchen Sie sofort medizinische Hilfe auf.

FR:Instructions de sécurité pour les piles

1. Ne jetez pas les piles bouton usagées ou les télécommandes à la poubelle ménagère. Pour protéger l' environnement et éviter tout risque de fuite dangereuse, veuillez suivre les consignes suivantes :

2. Retirez les piles bouton après usage et déposez-les dans un point de collecte local ou un centre de déchets dangereux.

3. Ne brûlez pas et ne démontez pas les piles, cela pourrait entraîner une explosion ou libérer des substances toxiques.

4. Si la télécommande n'est plus utilisée, déposez-la dans un centre de recyclage agréé pour appareils électroniques, afin de favoriser la réutilisation des ressources.

5. Gardez hors de portée des enfants pour éviter tout risque d'ingestion accidentelle ou de blessure.

6.Ce produit ne contient pas de pile. Veuillez l'acheter séparément. Le modèle de pile bouton compatible pour la télécommande est CR2025.3V

7.Si le ruban LED ne fonctionne pas, essayez d'abord de remplacer la pile. Si le problème persiste, contactez le vendeur.

8.**Tenez la télécommande éloignée des enfants — éloignez-la vraiment !** En cas d'ingestion accidentelle de la pile, consultez immédiatement un médecin.



Verification of Compliance

Verification No.:	MK24100179P01-E01
Name and address of Applicant:	Dongguan STTEAM Technology Co.,Ltd No.605, Diwang Square, Chang'an Town, Dongguan City,China
Name and address of Manufacturer:	Dongguan STTEAM Technology Co.,Ltd No.605, Diwang Square, Chang'an Town, Dongguan City,China
Product name:	Controller ambient light
Rated:	Input:5V --- 3A Output:5V --- 3A
Product model(s):	ST201, ST201A, ST201B, ST201C, ST201D, ST201E, ST201F, ST201G, ST201H
Product trademark:	N/A

This verification confirms that the product meets the requirements of the following standard.
The conformity was demonstrated based on following standard(s) listed by European Commission as harmonized with EMC Directive 2014/30/EU.

EN IEC 55015:2019+A11:2020
EN IEC 61547:2023

The verification has been carried out in accordance with individual rules and conditions agreed with the applicant. Evaluation has been carried out in accordance with:

Test report(s) No.:	MK24100179P01-E01
Test conducted by:	TMC Testing Services (Shenzhen) Co., Ltd.
Verification issue date:	October 31, 2024

Notes:

This verification refers to the above mentioned product and its conformity in regards of above mentioned standard(s) was proven on test sample.

This verification does not imply meeting all essential requirements, assessment of the series-production or any other restricted Notified Bodies conformity assessment procedure appropriate for the product.

This verification holder shall use this verification in connection to verification of conformity and technical data relevant for the product the verification was issued.

TMC Testing Services (Shenzhen) Co., Ltd.

t:86-755-86642861 cert@tmc-lab.com www.tmc-lab.com

1st Floor, Block A1, Zone A, Xinshidai Gongrong Industrial Park, No. 2, Shihuan Road, Shiyuan Street, Baoan District, Shenzhen, China

