

# MONTAGEANLEITUNG//ASSEMBLYINSTRUCTION

Artikel nummer/Item Number: N622P420761N

## Schreibtisch 80x60x(108-118CM)

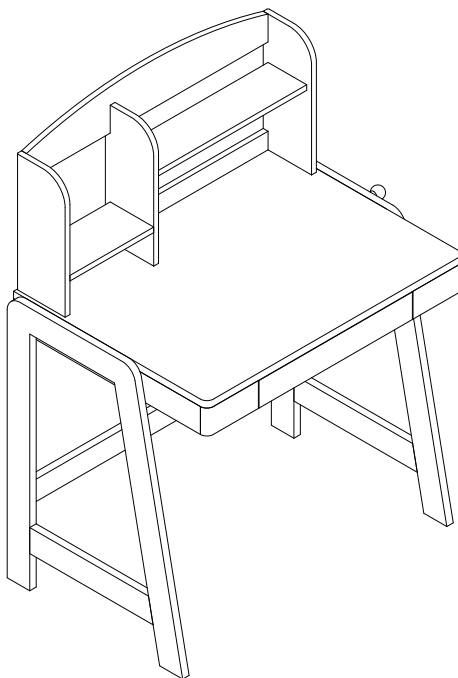

FR

Pensez à  
donner ou recycler.



Association

ou



Magasin

ou



Déchèterie

<https://quefairedemesdechets.fr>

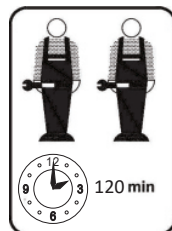

120 min

## English

**IMPORTANT ! KEEP FOR FUTURE REFERENCE: READ CAREFULLY**

- To be assembled by an adult. Assembly must be checked by an adult before use.
- During assembly children should be kept away from the product due to possible risk of injury.
- **WARNING !** Keep all screws, small parts and plastic bags out of the reach of children.
- Properly identify all parts before assembling.
- Anchor unit to stud or wall.
- Always use on a level, even surface.
- Avoid the risk of fire by not placing toy near sources of ignition or hot items.
- **DO NOT** place hot or cold items directly onto the surface.
- **DO NOT** place the item next to a radiator or direct sunlight.
- **DO NOT** allow children to climb on unit.
- **DO NOT** put the product in a humid environment.
- **DO NOT** use this item if any components are missing or damaged.

## Deutsch

**WICHTIG ! ZUM SPÄTEREN NACHSCHLAGEN AUFBEWAHREN: SORGFÄLTIG LESEN**

- Muss von einem Erwachsenen zusammengebaut werden. Der Zusammenbau muss vor der Benutzung von einem Erwachsenen überprüft werden.
- Bei der montage sollen kinder Von dem produkt getrennt werden, damit keine schäden entstehen
- **WARNUNG!** Bewahren Sie alle Schrauben, Kleinteile und Plastikbeutel außerhalb der Reichweite von Kindern auf.
- Kennzeichnen Sie vor dem Zusammenbau alle Teile ordnungsgemäß
- Verankern Sie das Gerät an einem Ständer oder einer Wand.
- Benutzen Sie das Gerät immer auf einer ebenen, geraden Fläche.
- Vermeiden Sie das Risiko eines Brandes, indem Sie die Spielzeug nicht in der Nähe von Zündquellen oder heißen Gegenständen aufstellen.
- Stellen Sie **KEINE** heißen oder kalten Gegenstände direkt auf die Oberfläche.
- Stellen Sie das Gerät **NICHT** in der Nähe eines Heizkörpers oder direkter Sonneneinstrahlung auf.
- Erlauben Sie Kindern **NICHT**, auf das Gerät zu klettern.
- Stellen Sie das Gerät **NICHT** in einer feuchten Umgebung auf.
- Bitte benutzen sie dieses produkt nicht, wenn ein teil abhanden gekommen Oder beschädigt ist.

## Français

**IMPORTANT ! CONSERVER POUR RÉFÉRENCE ULTÉRIEURE : LIRE ATTENTIVEMENT**

- A assembler par un adulte. Le montage doit être vérifié par un adulte avant utilisation.
- Pendant l'assemblage, les enfants doivent être tenus à l'écart du produit en raison du risque possible de blessure.
- **ATTENTION!** Conservez toutes les vis, les petites pièces et les sacs en plastique hors de portée des enfants.
- Identifiez correctement toutes les pièces avant de les assembler
- Fixer l'appareil à un montant ou à un mur
- Utilisez toujours l'appareil sur une surface plane et uniforme.
- Évitez les risques d'incendie en ne plaçant pas les jouet à proximité de sources d'inflammation ou d'objets chauds.
- **NE PAS** placer d'objets chauds ou froids directement sur la surface.
- **NE PAS** placer l'appareil à côté d'un radiateur ou de la lumière directe du soleil.
- **NE PAS** laisser les enfants grimper sur l'appareil.
- **NE PAS** placer le produit dans un environnement humide.
- N'utilisez pas cet article si des composants sont manquants ou endommagés

## Italiano

**IMPORTANTE! CONSERVARE PER RIFERIMENTO FUTURO: LEGGERE ATTENTAMENTE**

- Deve essere assemblato da un adulto. l'assemblaggio deve essere controllato da un adulto prima dell'uso.
- Durante il montaggio i bambini devono essere tenuti lontani dal prodotto a causa del possibile rischio di lesioni.
- **AVVERTENZA !** Tenere tutte le viti, le piccole parti e i sacchetti di plastica fuori dalla portata dei bambini.
- Identificare correttamente tutte le parti prima dell'assemblaggio.
- Ancorare l'unitj a un pilastro o a una parete.
- Utilizzare sempre su una superficie piana e uniforme.
- Evitare il rischio di incendio non collocando i giocattoli vicino a fonti di accensione o ad oggetti caldi.
- **NON** collocare oggetti caldi o freddi direttamente sulla superficie.
- **NON** collocare l'apparecchio vicino a un termosifone o alla luce diretta del sole.
- **NON** permettere ai bambini di arrampicarsi sull'unitj.
- **NON** collocare il prodotto in un ambiente umido.
- **NON** utilizzare questo eleN' utilisez pas cet article si des composants sont manquants ou endommagésmento se alcuni componenti sono mancanti o danneggiati

## Español

**¡IMPORTANTE ! CONSERVELO PARA FUTURAS CONSULTAS: LEA ATENTAMENTE**

- Debe montarlo un adulto. El montaje debe ser comprobado por un adulto antes del uso.
- Durante el montaje los niños deben mantenerse alejados del producto debido al posible riesgo de lesión.
- **ADVERTENCIA** Mantenga todos los tornillos, piezas pequeñas y bolsas de plástico fuera del alcance de los niños.
- Iden que correctamente todas las piezas antes del montaje.
- Ancle la unidad a un montante o pared.
- U lícelo siempre sobre una superficie plana y nivelada.
- Evite el riesgo de incendio no colocando los juguete cerca de fuentes de ignición o artículos calientes.
- **NO** coloque objetos calientes o fríos directamente sobre la superficie.
- **NO** coloque el mueble cerca de un radiador o de la luz solar directa.
- **NO** permita que los niños se suban a la unidad.
- **NO** coloque el producto en un ambiente húmedo.
- **NO** utilice este artículo si algún componente falta o está dañado.

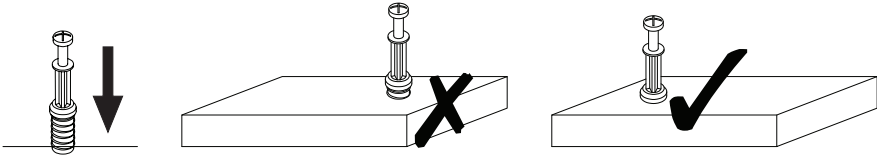

**EN\_QUICKFIT:**Tighten quickfit until shoulder is flush with panel.Do not overtighten or undertighten.

**FR\_RACCORD RAPIDE:**Faites serrer le raccord rapide jusqu'à ce que l'épaulement soit parfaitement encastré dans le panneau. Il ne faut ni trop serrer ni insuffisamment serrer.

**ES\_QUICKFIT:**Apriete quickfit hasta que el hombro se descargue con el panel. NO lo sobreapriete nilo apriete poco.

**DE\_QUICKFIT:**Ziehen Sie den Quickfit fest, bis die Schulter mit der Platte bündig ist. Bitte nicht zu fest oder zu schwach anziehen.

**IT\_MONTAGGIO RAPIDO:**Stringere il montaggio rapido fino a quando la spalla è a filo conilpanneo.non stringere troppo o troppo poco

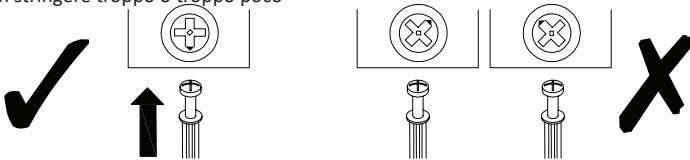

**EN\_CAM LOCK:**When fitting cam lock, ensure starting position is correct before you insert connecting quickfit.

**FR\_SERRURE BATTEUSE:**Avant d'insérer la serrure batteuse, veillez à la bonne orientation avant d'insérerle raccord rapide.

**ES\_CERREDELACAMARA:**Cuando instale el cierre de la càmara, asegurese de que la posición de inicio es correcta antes de que inserte el quickfit conector.

**DE\_CAM-LOCK:**Achten Sie beider Montage des Cam-Locks auf die richtige Ausgangsposition,bevor Sie den Quickfit einsetzen.

**IT\_BLOCCAGGIO ACAMMA:**Quando si monta il bloccaggio a camma, assicurarsi che la posizione iniziale sia corretta prima di inserire il montaggio rapido di collegamento.

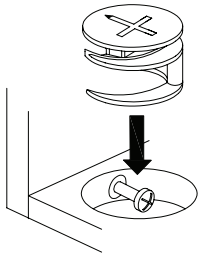

**EN**\_To adjust the gap from the door to the main frame turn the screw clockwise or anti-clockwise as needed.

**FR**\_Si vous souhaitez ajuster l'écart entre la porte et le cadre principal, tournezla vis dans le sens des aiguilles d'une montreou dansle sensinverse,si nécessaire.

**ES**\_Para ajustarelespacio desde la puerta al marco principal, gire el tornillo en sentido horario o antihorario,segun se necesite.

**DE**\_Um den Abstand von derTürzum Hauptrahmen auszurichten,drehen Sie die Schraube je nach Bedarf im oder gegen den Uhrzeigersinn.

**IT**\_Perregolare lo spazio tra la porta e il telaio principale, avvitare o svitare la vite secondo necessità.

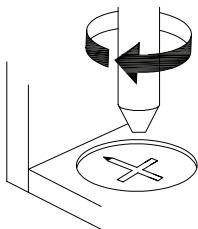

**EN**\_Turn cam lock clockwise to tighten.

**FR**\_Faites tourner la serrure batteuse dans le sens des aiguilles d'une montre pourla resserrer.

**ES**\_Gire el cierre de la cjmara en sentido horario para apretarlo.

**DE**\_rehen Sie den Cam-Lockim Uhrzeigersinn, umihnfestzuziehen.

**IT**\_Ruotare il bloccaggio a camma in senso orario per stringere.



**DE:** Vor dem Einbau die Schrauben in die Löcher stecken und festziehen, aber nicht bis 100%, 70% bis 80% anziehen reicht aus. Schließlich, nachdem alle Schrauben installiert sind, ziehen Sie alle Schrauben auf 100%.

Wenn Sie auf diese Probleme stoßen, wie z. B. Fehlausrichtung der Löcher oder Unfähigkeit, bestimmte Teile zu installieren, überprüfen Sie bitte, ob die Schrauben korrekt verwendet werden und passen Sie die Dichtigkeit der Schrauben an.

**UK:** Before installation, insert the screws into the holes and tighten them, but do not tighten them to 100%, 70% to 80% is sufficient. Finally, after all screws are installed, tighten all screws to 100%.

If you encounter these issues, such as if the holes cannot be aligned or some parts cannot be installed, please check if the screws are used correctly and adjust the tightness of the screws.

**FR:** Insérer la vis dans le trou avant la fin de l'assemblage, serrer la vis, mais ne pas serrer à 100%, 70% ~ 80% est correct. Enfin, une fois que toutes les vis sont bien serrées, toutes les vis sont serrées à 100%.

Si vous rencontrez ces problèmes, par exemple si les trous ne sont pas alignés ou si certaines pièces ne peuvent pas être montées, vérifiez que les vis sont utilisées correctement et Ajustez leur serrage.



[DE]

Warnung: Dieses Produkt ist nicht für Kinder unter 72 Monaten geeignet.

Warnung: Aufgrund der Kleinteile sollten Kinder das Produkt nur unter Aufsicht von Erwachsenen verwenden, um die Gefahr des Verschluckens zu vermeiden.

Warnung: Um die Sicherheit zu gewährleisten, befolgen Sie bitte die Anweisungen zur korrekten Installation und holen Sie sich bei Bedarf professionelle Hilfe.

Warnung: Stellen Sie Möbel nicht in der Nähe von Feuerquellen oder Gegenständen mit hoher Temperatur auf, um Brandgefahr zu vermeiden.

[EN]

Warning: Not suitable for children under 72 months.

Warning: Due to the small parts of the product, children should only use it under adult supervision to avoid a swallowing hazard.

Warning: To ensure safety, please follow the instructions for correct installation and seek professional assistance if necessary.

Warning: Do not place furniture close to fire sources or high-temperature objects to avoid the risk of fire.

[FR]

Avertissement : Ce produit ne convient pas aux enfants de moins de 72 mois.

Avertissement : En raison des petites pièces du produit, les enfants ne doivent l'utiliser que sous la surveillance d'un adulte afin d'éviter tout risque d'ingestion.

Avertissement : Pour garantir la sécurité, veuillez suivre les instructions pour une installation correcte et demander l'aide d'un professionnel si nécessaire.

Avertissement : Ne placez pas les meubles à proximité de sources d'incendie ou d'objets à haute température pour éviter tout risque d'incendie.

[IT]

Attenzione: Questo prodotto non è adatto ai bambini di età inferiore ai 72 mesi.

Attenzione: A causa delle piccole parti del prodotto, i bambini devono utilizzarlo solo sotto la supervisione di un adulto per evitare il rischio di soffocamento.

Attenzione: Per garantire la sicurezza, seguire le istruzioni per una corretta installazione e, se necessario, richiedere assistenza professionale.

Attenzione: Non posizionare i mobili vicino a fonti di fuoco o oggetti ad alta temperatura per evitare il rischio di incendio.

[ES]

Advertencia: Este producto no es adecuado para niños menores de 72 meses.

Advertencia: Debido a las pequeñas piezas del producto, los niños sólo deben utilizarlo bajo la supervisión de un adulto para evitar el riesgo de asfixia.

Advertencia: Para garantizar la seguridad, siga las instrucciones para una instalación correcta y busque asistencia profesional si es necesario.

Advertencia: No coloque muebles cerca de fuentes de fuego u objetos de alta temperatura para evitar el riesgo de incendio.

# Schreibtisch

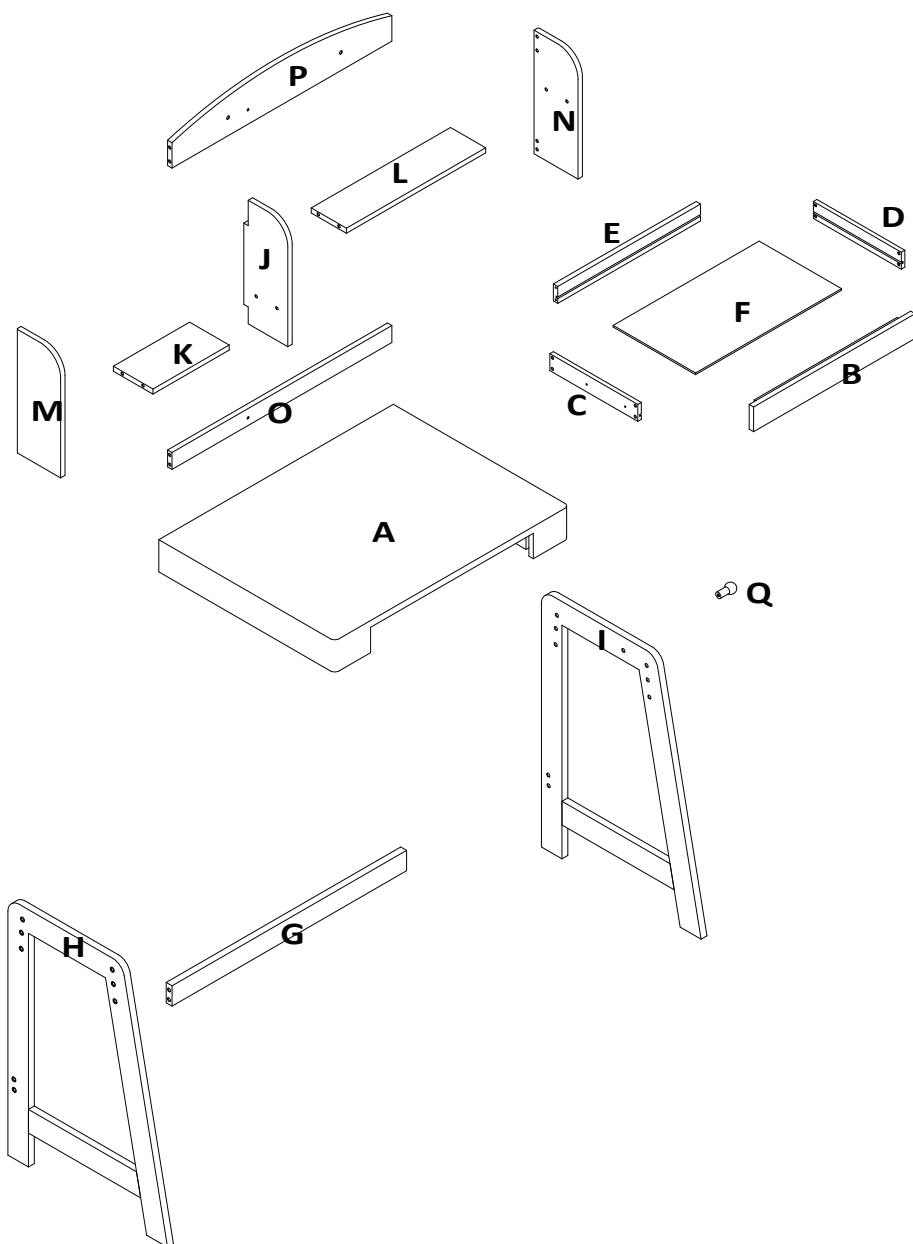

# DESK

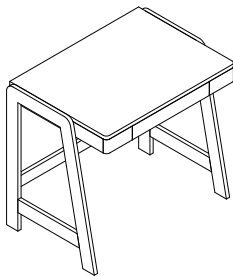

N622P420761N

**A** x1

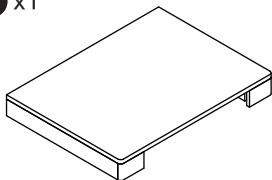

**B** x1

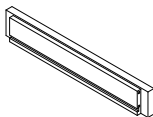

**C** x1

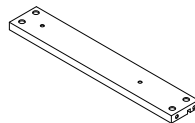

**D** x1

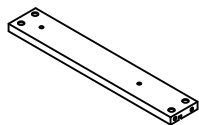

**E** x1

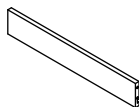

**F** x1

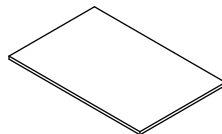

**G** x1

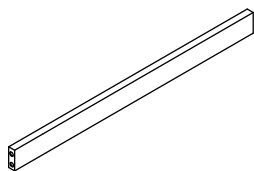

**H** x1

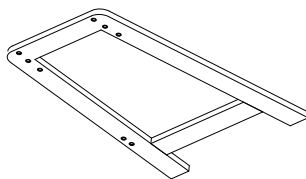

**I** x1

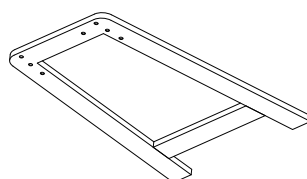

**Q** x1



# BOOKSEHLF

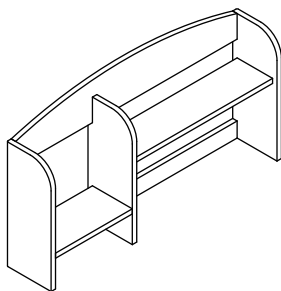

N622P420761N

**J** x1

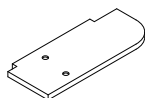

**K** x1

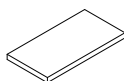

**L** x1

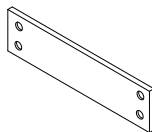

**M** x1

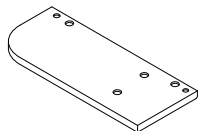

**N** x1

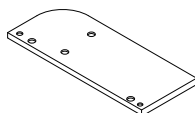

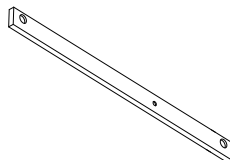

**O** x1



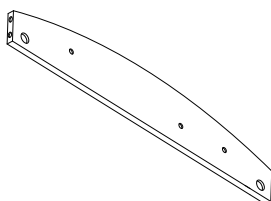

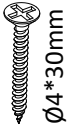
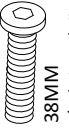
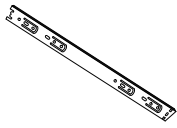

**P** x1







# DESK-HARDWARE

<p><b>1</b></p>  <p>Ø3*12mm</p> <p><b>8 x</b></p>	<p><b>2</b></p>  <p>Ø4*30mm</p> <p><b>8 x</b></p>	<p><b>3</b></p>  <p>38MM Ø1/4*1-1/2"</p> <p><b>8 x</b></p>	<p><b>4</b></p>  <p><b>2 x</b></p>	<p><b>5</b></p>  <p>M4*18mm</p> <p><b>1 x</b></p>
<p><b>7</b></p>  <p><b>1 x</b></p>				

# BOOKSHELT-HARDWARE

<p><b>8</b></p>  <p>Ø8*30mm</p> <p><b>12 x</b></p>	<p><b>9</b></p>  <p>Ø8*30mm</p> <p><b>12x</b></p>	<p><b>2</b></p>  <p>Ø4*30mm</p> <p><b>2 x</b></p>	<p><b>3</b></p>  <p>Ø8*30mm</p> <p><b>4 x</b></p>	
---	--	--	--	--

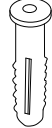
# Fall-off/Tilting Prevention Devices

<p><b>15</b></p>  <p><b>2 x</b></p>	<p><b>16</b></p>  <p>Ø3*19mm</p> <p><b>4 x</b></p>	<p><b>17</b></p>  <p>Ø4*35mm</p> <p><b>2 x</b></p>	<p><b>18</b></p>  <p>Ø4*35mm</p> <p><b>2 x</b></p>	
--	---	---	--	--

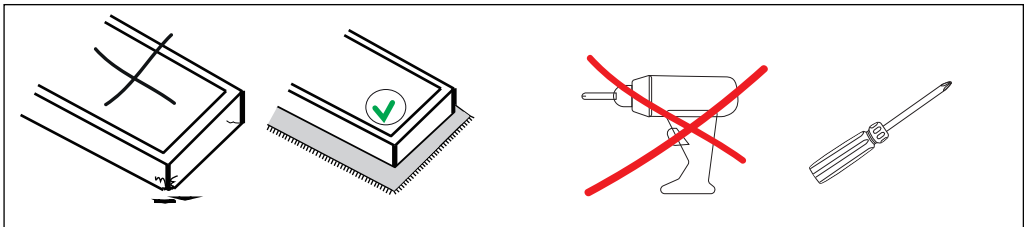

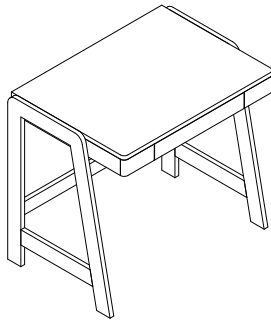

### Schritt 1

4

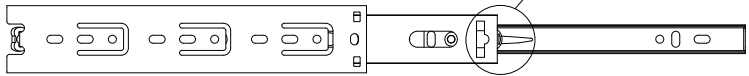
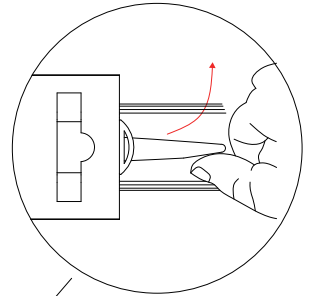
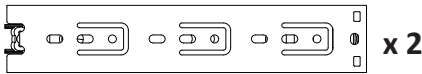

Part 1



Part 2

# Schritt 2

<b>1</b>		<b>2</b>
	Ø3*12mm	

Part 1

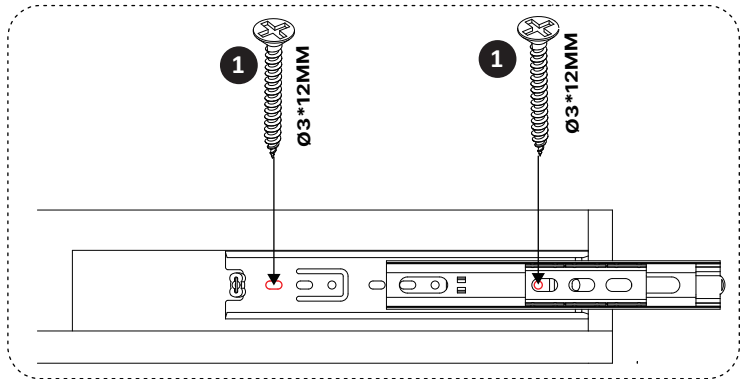
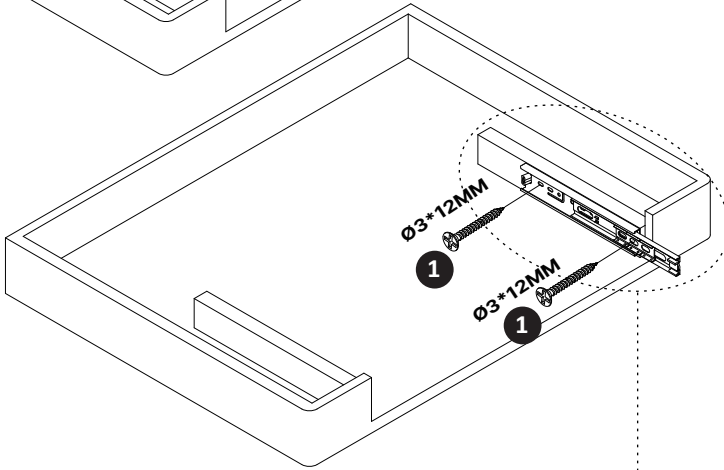
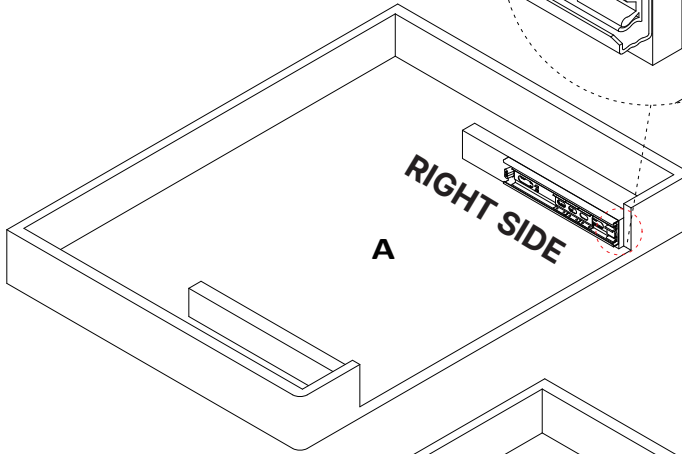
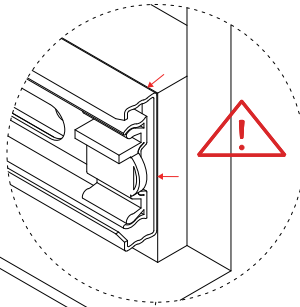

# Schritt 3

## Part 1



<b>1</b>		<b>2</b>
$\varnothing 3 \times 12 \text{mm}$		

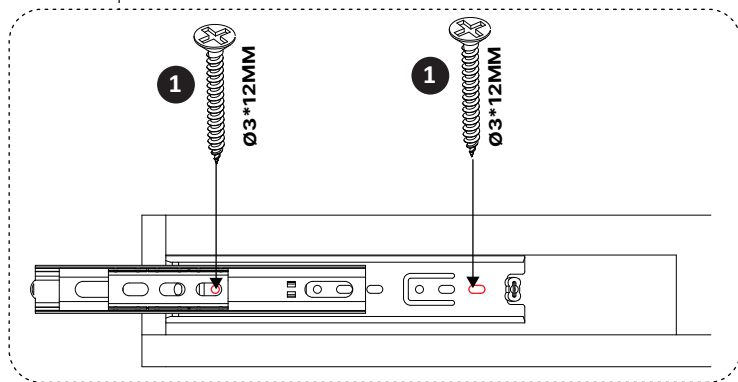
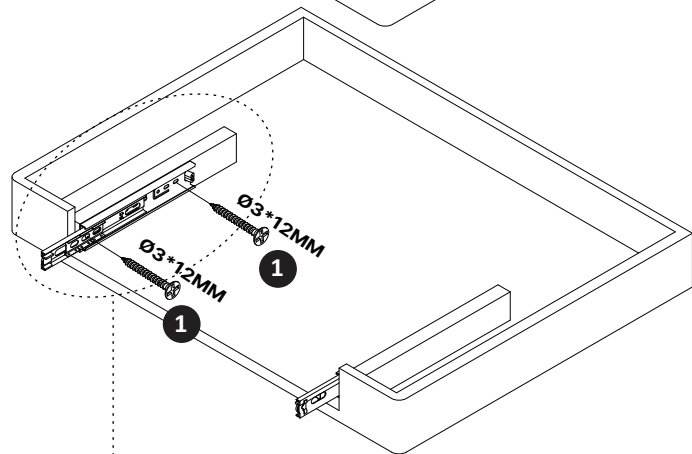
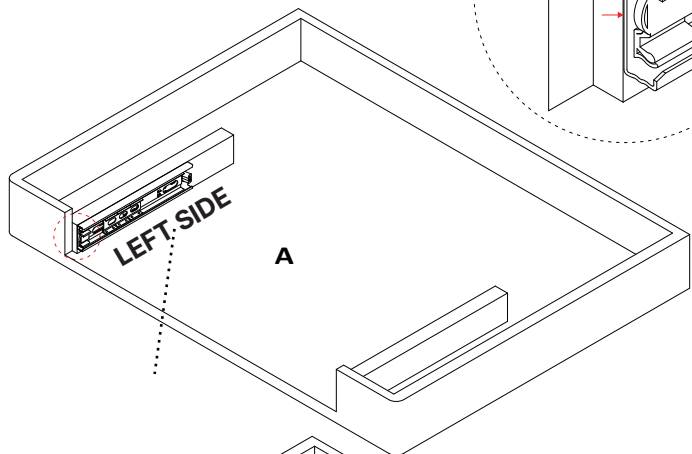
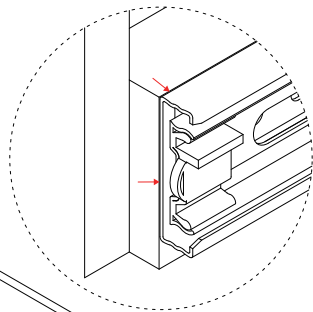

## Schritt 4

2

Ø4\*30mm

4

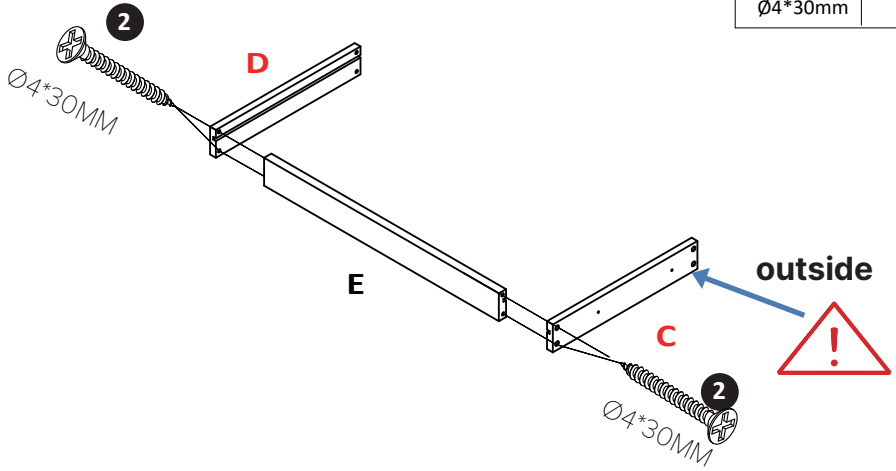

## Schritt 5

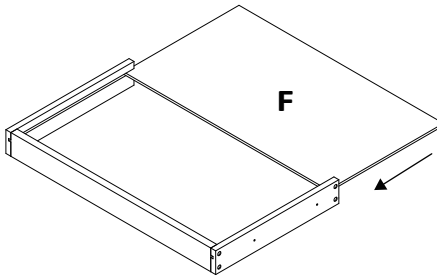

## Schritt 6

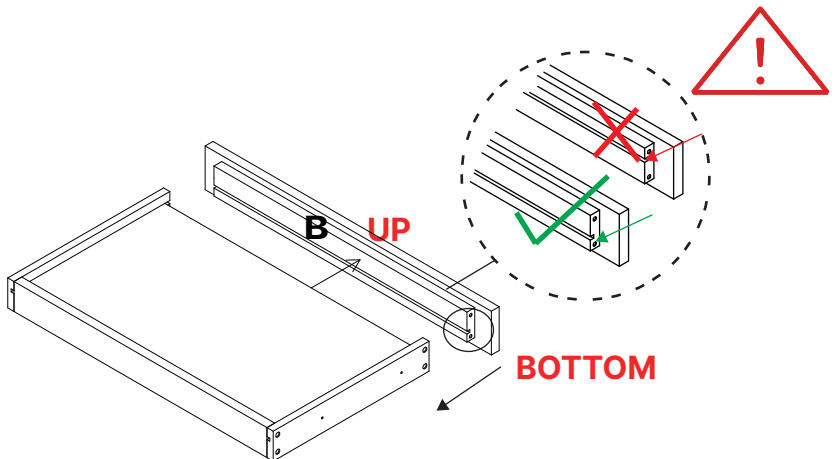

## Schritt 7

2

Ø4\*30mm

4

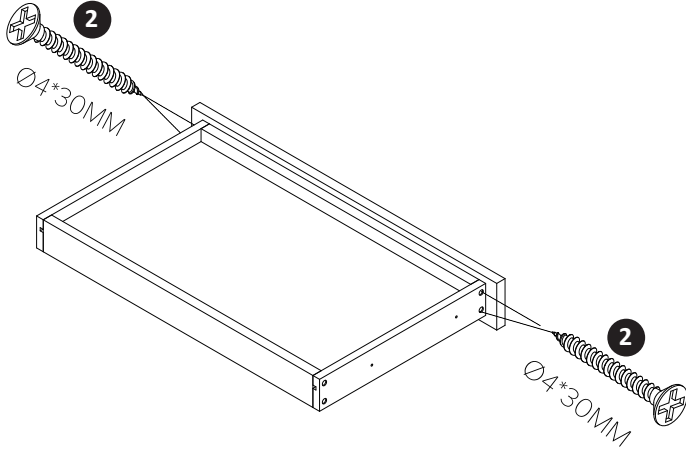

## Schritt 8

Part 2



2

1

Ø3\*12mm

4

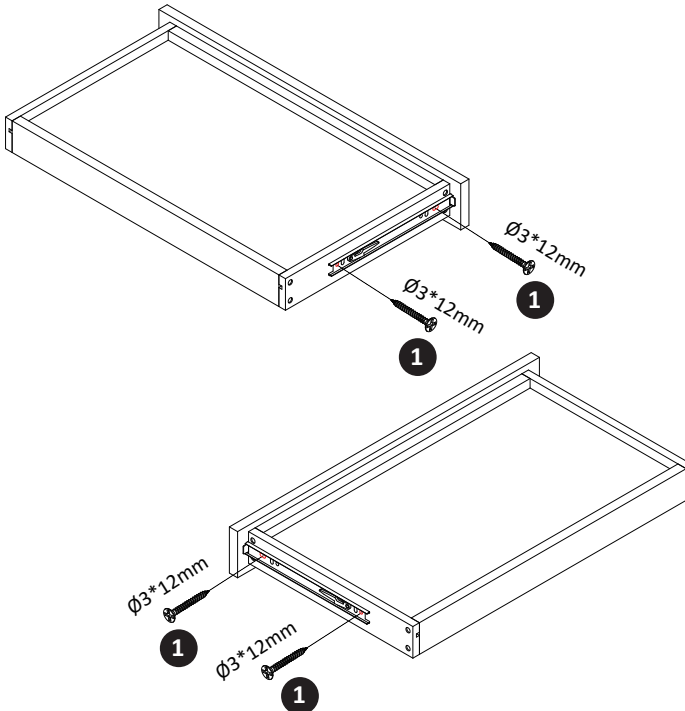

# Schritt 9

<b>5</b>		<b>1</b>
M4*18MM		

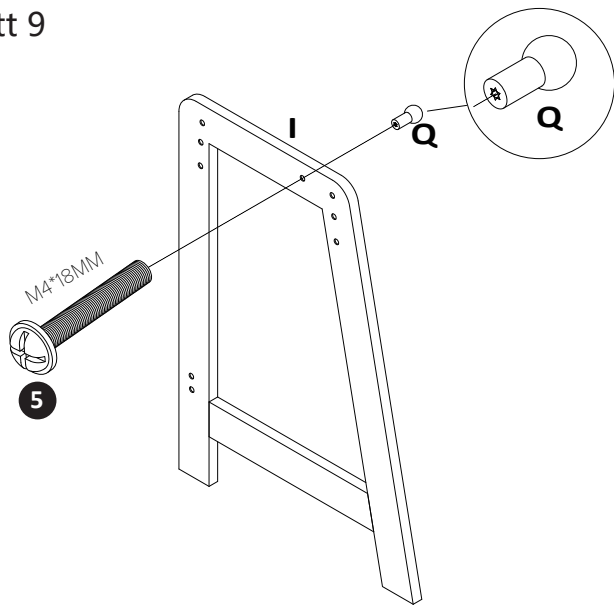

# Schritt 10

<b>3</b>		<b>4</b>
38MM Ø1/4*1-1/2"		

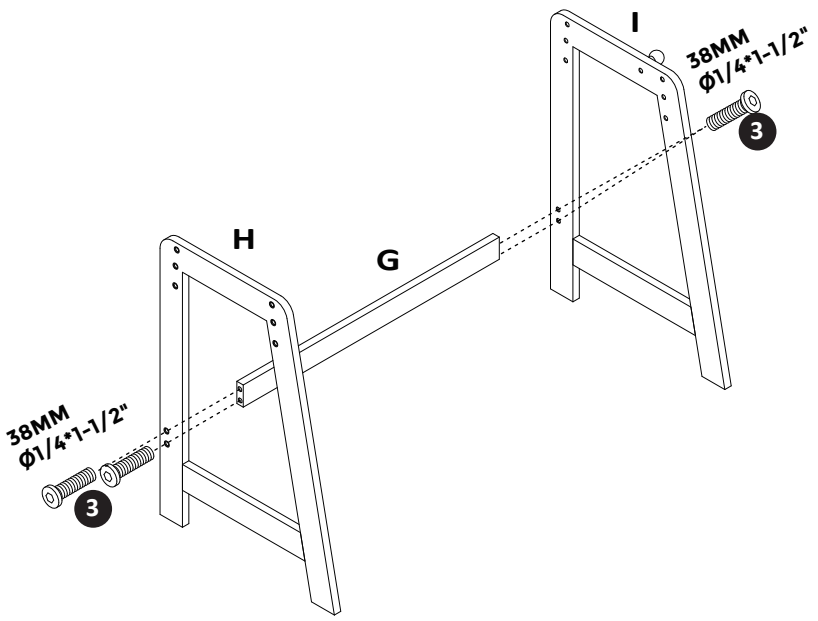

Schritt 12

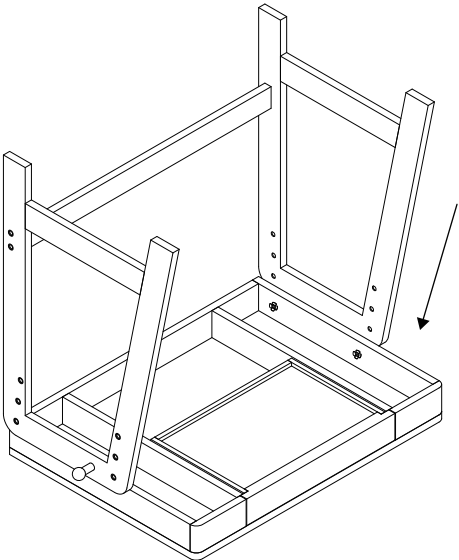

Schritt 13

<b>3</b>	 38MM Ø1/4*1-1/2"	<b>4</b>
----------	--	----------

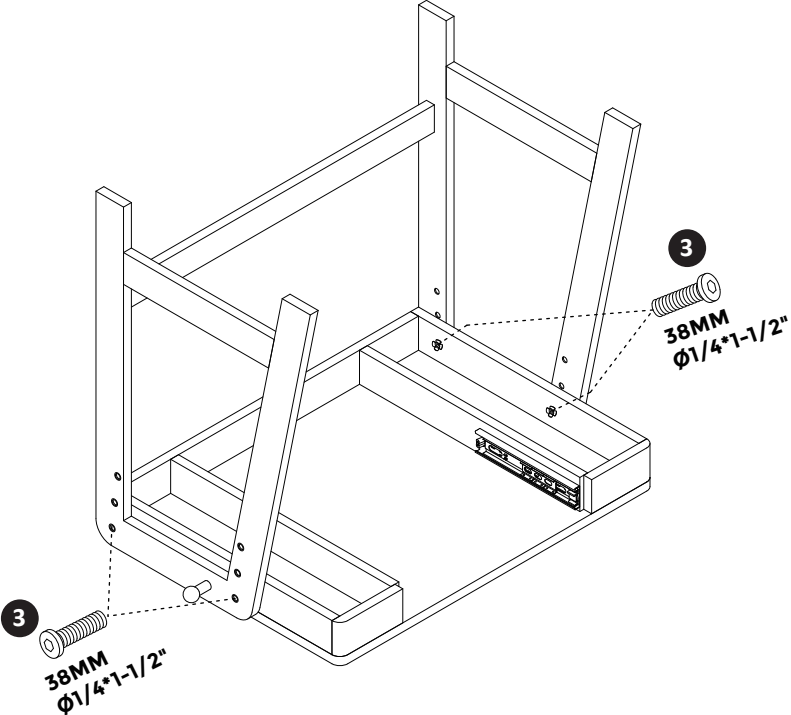

# Schritt 14

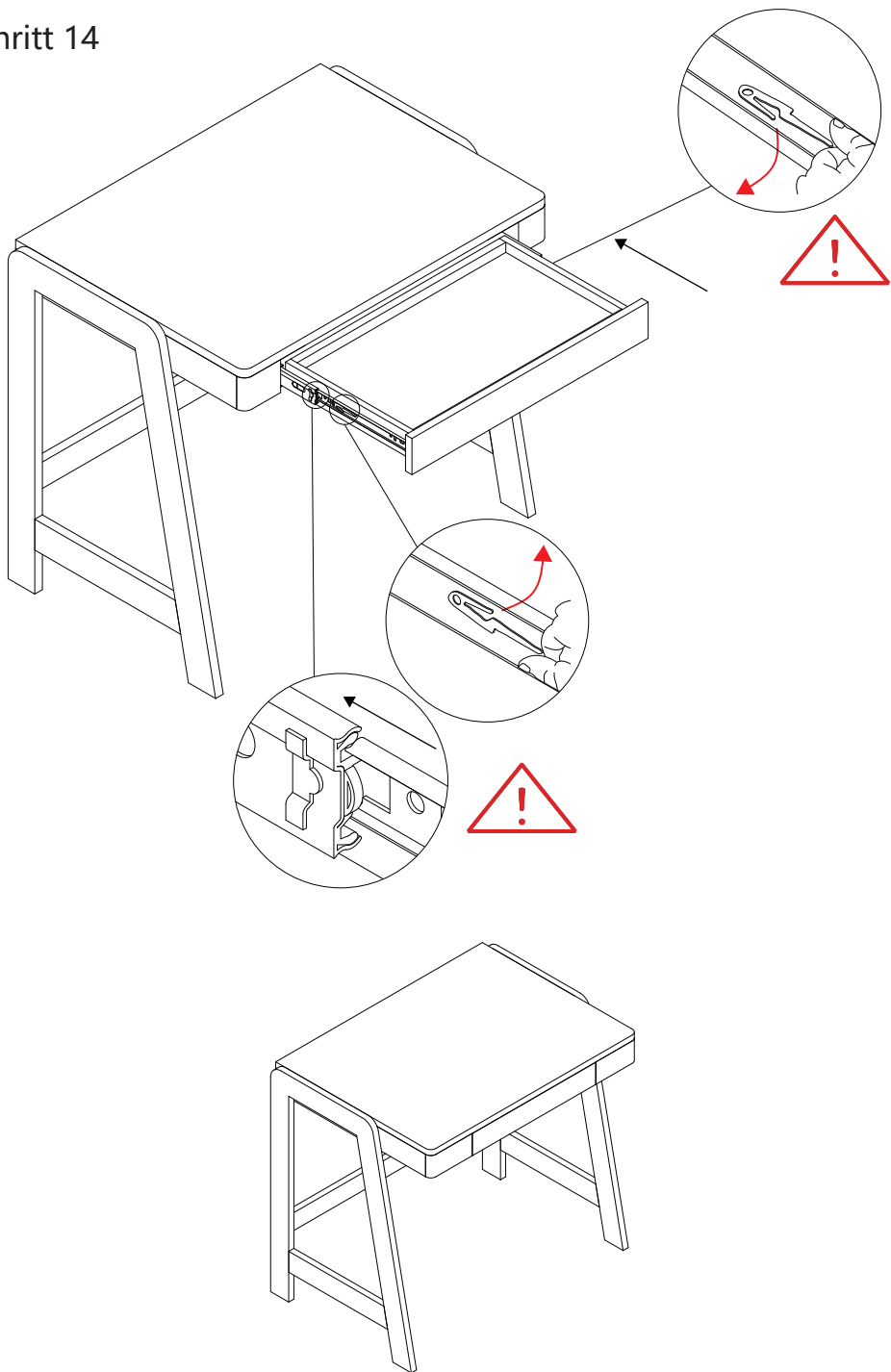

# BOOKSHELT

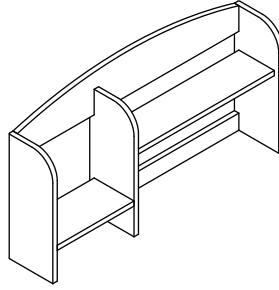

## Schritt 1

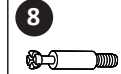
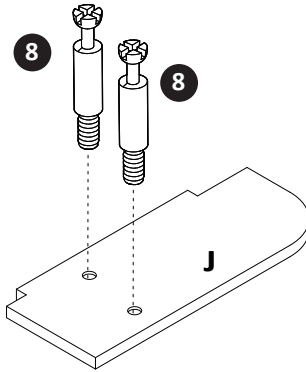

2

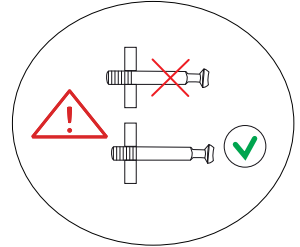

## Schritt 2

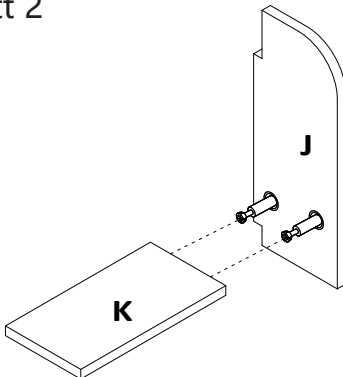

### Schritt 3

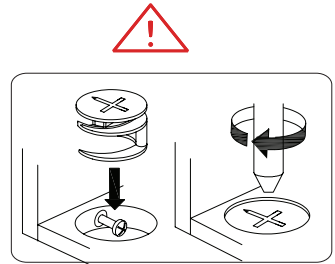
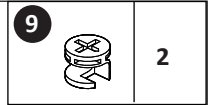
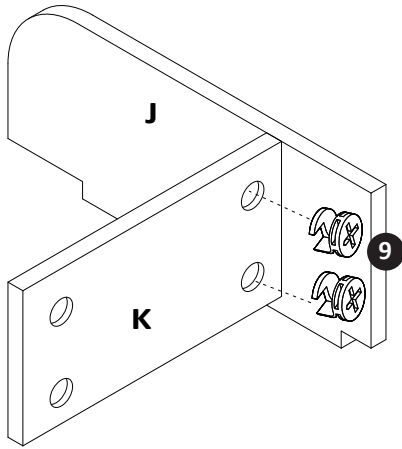

### Schritt 4

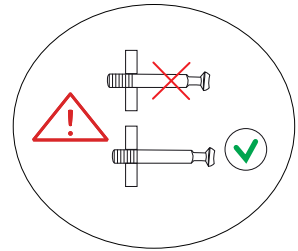
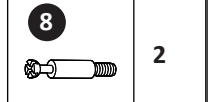
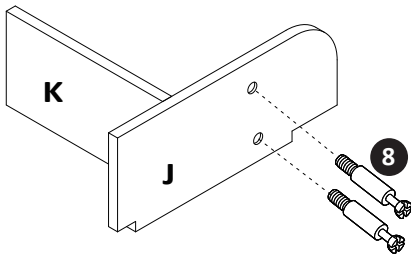

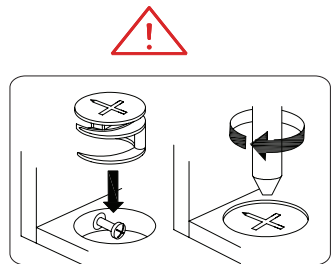
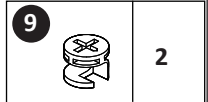
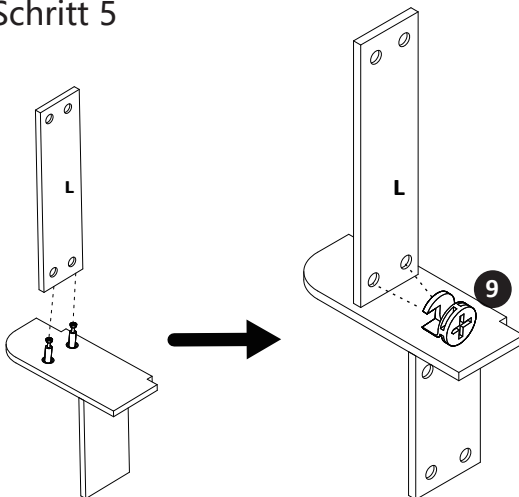

### Schritt 5

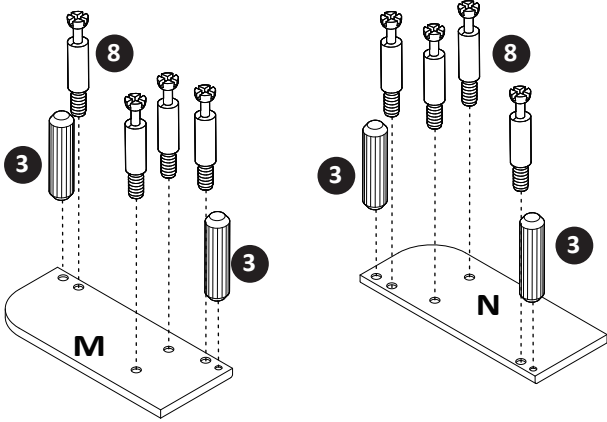

# Schritt 6



<b>3</b>	4
	
$\varnothing 8 \times 30 \text{mm}$	
<b>8</b>	8
	

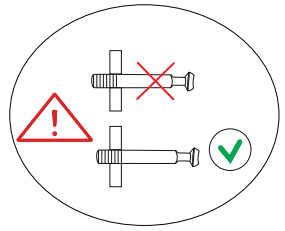

# Schritt 7

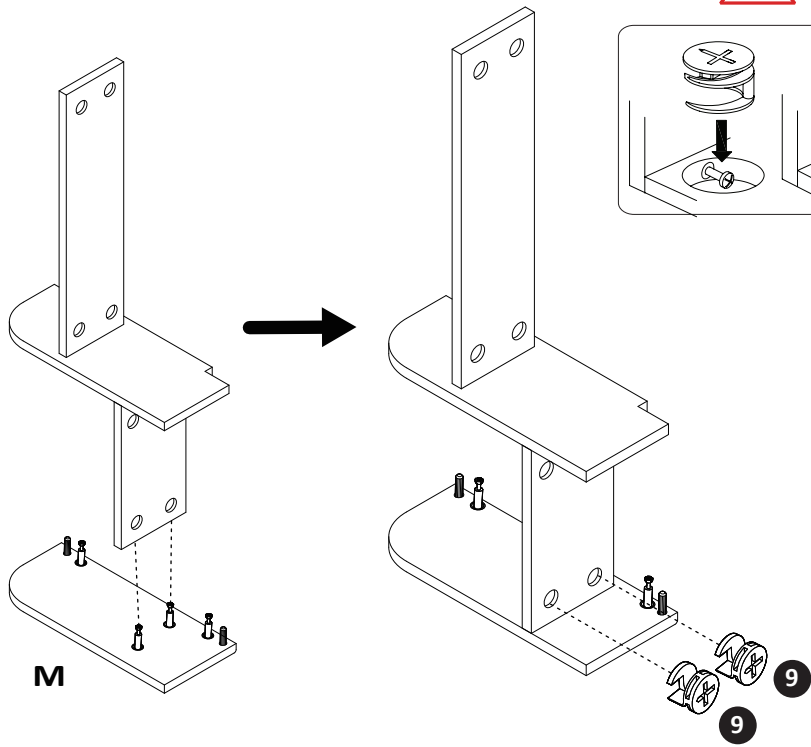

<b>9</b>	2
	

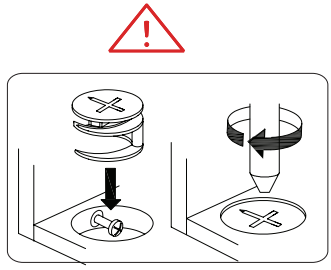

# Schritt 8

<b>9</b>		<b>2</b>
----------	--	----------

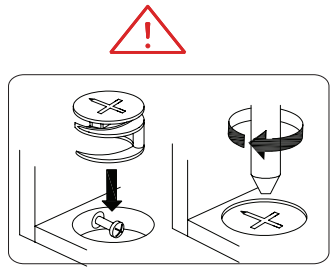
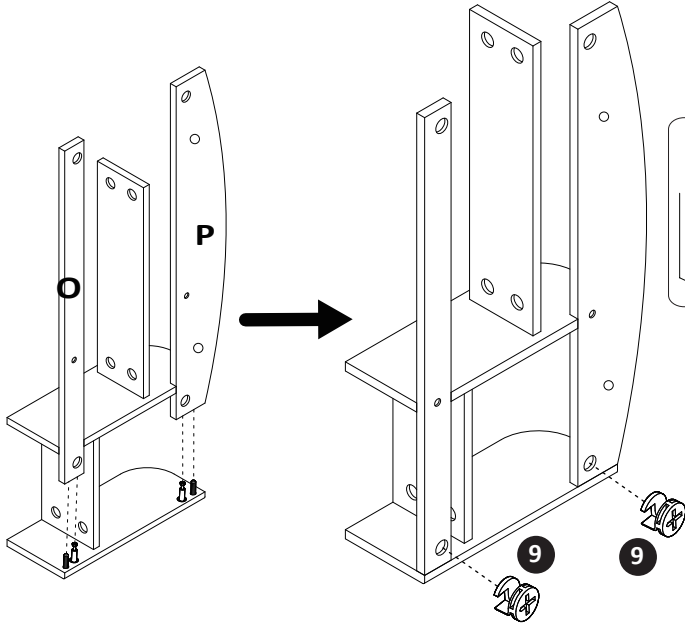

# Schritt 9

<b>2</b>		<b>2</b>
----------	---	----------

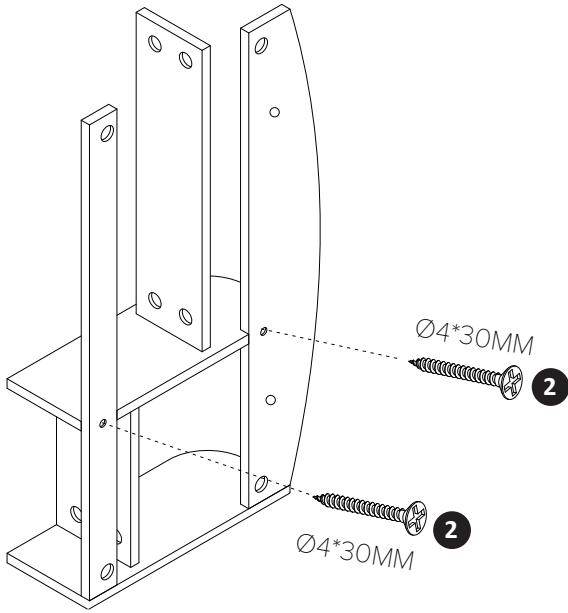

# Schritt 10

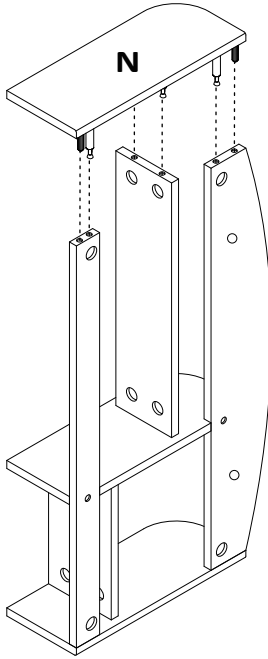

# Schritt 11

<b>9</b>		<b>4</b>
----------	---	----------

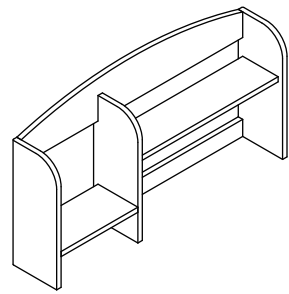
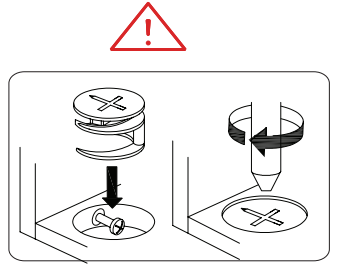
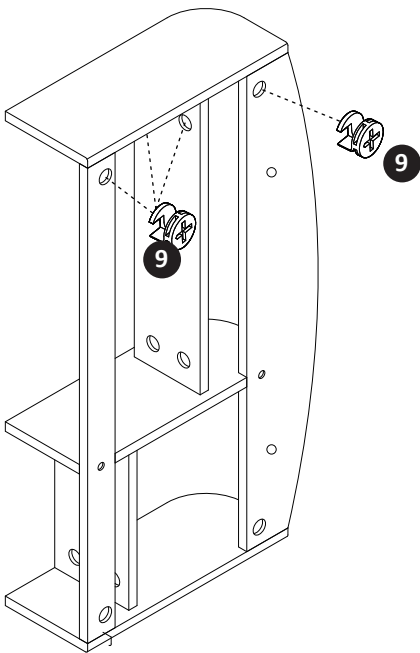

# DESK High Adjust

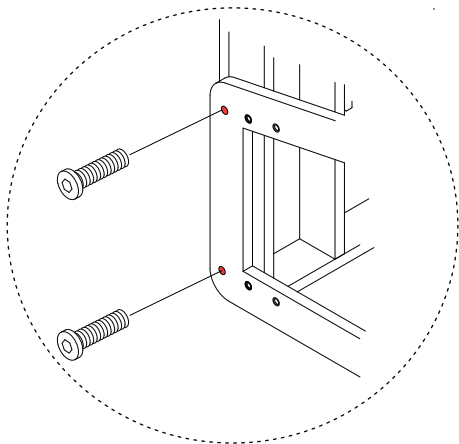
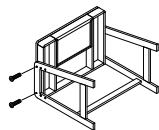

H1

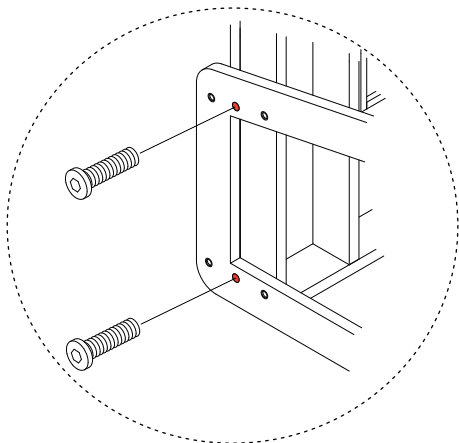
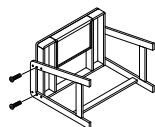
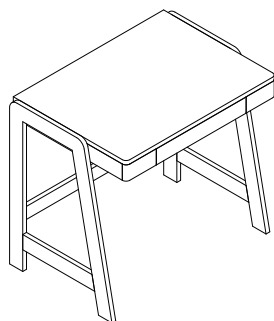

H2

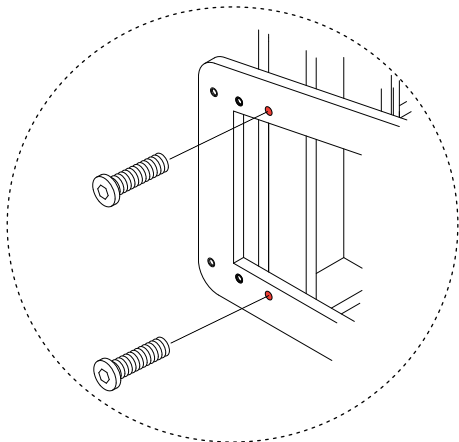
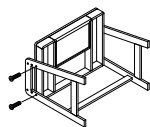
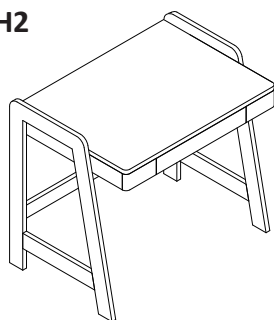

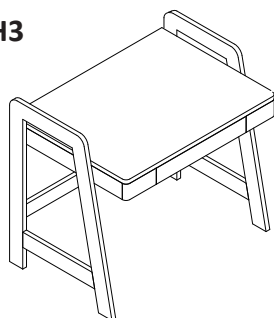

H3

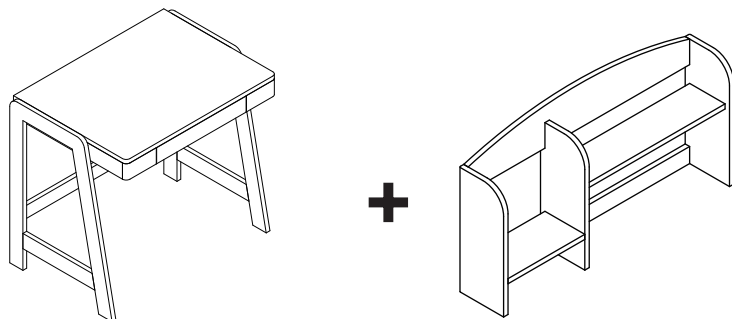

# DESK + BOOKSHELT



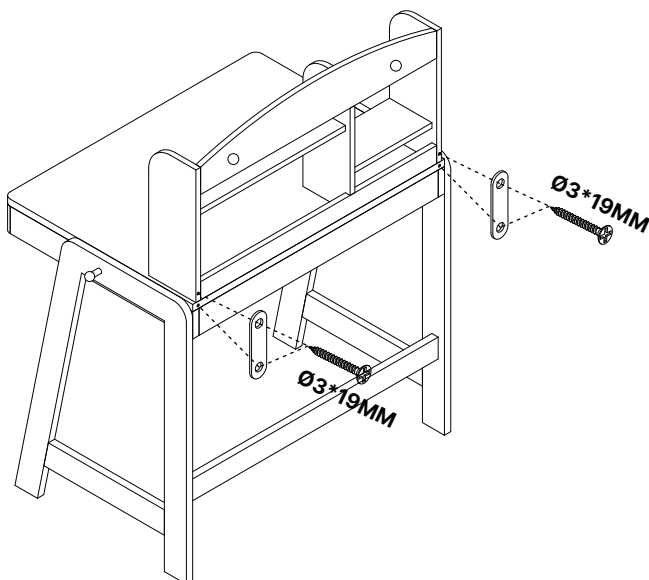

Schritt 1

<b>15</b> 	2
<b>16</b>  Ø3*19mm	4

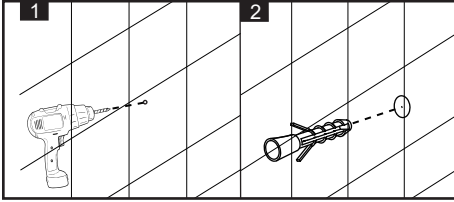
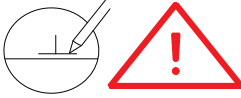

# Schritt 2

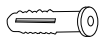

<b>17</b> 	2
<b>18</b>  Ø4*35mm	2

