

FR Description du produit
EN Product description
ES Descripción del producto
DE Produktbeschreibung

IT Descrizione del prodotto
NL Productomschrijving
PT Descrição do produto
PL Opis produktu

Matelas



Vente-unique.com

Français (FR)

Lisez attentivement cette notice avant d'utiliser le matelas.

- Conservez cette notice pour référence future.
- Ne laissez pas les sacs en plastique à portée des enfants. Risque d'étouffement.
- Déballez le matelas dans une pièce bien ventilée.
- Respecter le temps de décompression de 72 heures avant utilisation.
- Déployez le matelas sur une surface plane et propre.
- Assurez-vous que le matelas soit correctement positionné sur le support recommandé.
- Ne placez pas le matelas près d'une flamme ouverte ou d'une source de chaleur.

English (EN)

Read this manual carefully before using the mattress.

- Keep this manual for future reference.
- Do not leave plastic bags within the reach of children. Risk of suffocation.
- Unpack the mattress in a well-ventilated room.
- Allow 72 hours for decompression before use.
- Place the mattress on a clean, flat surface.
- Ensure the mattress is properly positioned on the recommended support.
- Do not place the mattress near an open flame or heat source.

Deutsch (DE)

Lesen Sie diese Anleitung sorgfältig durch, bevor Sie die Matratze verwenden.

- Bewahren Sie diese Anleitung für zukünftige Referenz auf.
- Plastiktüten nicht in Reichweite von Kindern lassen. Erstickungsgefahr.
- Packen Sie die Matratze in einem gut belüfteten Raum aus.
- Lassen Sie die Matratze 72 Stunden zur Entfaltung ruhen, bevor Sie sie verwenden.
- Legen Sie die Matratze auf eine saubere, ebene Fläche.
- Stellen Sie sicher, dass die Matratze korrekt auf der empfohlenen Unterlage positioniert ist.
- Platzieren Sie die Matratze nicht in der Nähe von offenen Flammen oder Wärmequellen.

Italiano (IT)

Leggere attentamente queste istruzioni prima di utilizzare il materasso.

- Conservare queste istruzioni per riferimento futuro.
- Non lasciare i sacchetti di plastica alla portata dei bambini. Rischio di soffocamento.
- Disimballare il materasso in una stanza ben ventilata.
- Attendere 72 ore per la decompressione prima dell'uso.
- Posizionare il materasso su una superficie piana e pulita.
- Assicurarsi che il materasso sia correttamente posizionato sul supporto raccomandato.
- Non posizionare il materasso vicino a fiamme libere o fonti di calore.

Español (ES)

Lea atentamente este manual antes de usar el colchón.

- Conserve este manual para futuras consultas.
- No deje bolsas de plástico al alcance de los niños. Riesgo de asfixia.
- Desempaque el colchón en una habitación bien ventilada.
- Espere 72 horas para que el colchón se descomprima antes de usarlo.
- Coloque el colchón sobre una superficie limpia y plana.
- Asegúrese de que el colchón esté correctamente colocado sobre el soporte recomendado.

- No coloque el colchón cerca de llamas abiertas o fuentes de calor.
-

Português (PT)

Leia atentamente este manual antes de usar o colchão.

- Guarde este manual para referência futura.
 - Não deixe sacos plásticos ao alcance de crianças. Risco de asfixia.
 - Desembale o colchão em um local bem ventilado.
 - Aguarde 72 horas para a descompressão antes de usar.
 - Coloque o colchão sobre uma superfície limpa e plana.
 - Certifique-se de que o colchão esteja corretamente posicionado no suporte recomendado.
 - Não coloque o colchão próximo a chamas abertas ou fontes de calor.
-

Polski (PL)

Przeczytaj uważnie tę instrukcję przed użyciem materaca.

- Zachowaj tę instrukcję na przyszłość.
 - Nie pozostawiaj plastikowych toreb w zasięgu dzieci. Ryzyko uduszenia.
 - Rozpakuj materac w dobrze wentylowanym pomieszczeniu.
 - Odczekaj 72 godziny na pełne rozłożenie przed użyciem.
 - Umieść materac na czystej i płaskiej powierzchni.
 - Upewnij się, że materac jest prawidłowo umieszczony na zalecanym podparciu.
 - Nie umieszczaj materaca w pobliżu otwartego ognia ani źródeł ciepła.
-

Nederlands (NL)

Lees deze handleiding zorgvuldig door voordat u de matras gebruikt.

- Bewaar deze handleiding voor toekomstig gebruik.
- Laat plastic zakken niet binnen het bereik van kinderen. Verstikkingsgevaar.
- Pak de matras uit in een goed geventileerde ruimte.
- Laat de matras 72 uur decomprimeren voordat u deze gebruikt.
- Leg de matras op een schone, vlakke ondergrond.
- Zorg ervoor dat de matras correct is geplaatst op het aanbevolen ondersteuningssysteem.
- Plaats de matras niet in de buurt van een open vlam of warmtebron.



Vente-unique.com

VS-Jul-2024

Imported by - Importé par

CAFOM DISTRIBUTION

9 Rue Jacquart 93310 Le Pré-Saint-Gervais

FR Description du produit

EN Product description

ES Descripción del producto

DE Produktbeschreibung

IT Descrizione del prodotto

NL Productomschrijving

PT Descrição do produto

PL opis produktu

Lit coffre TEOMIS 140 x 190cm

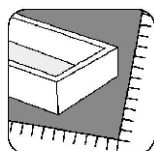
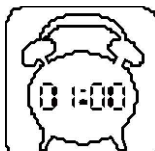
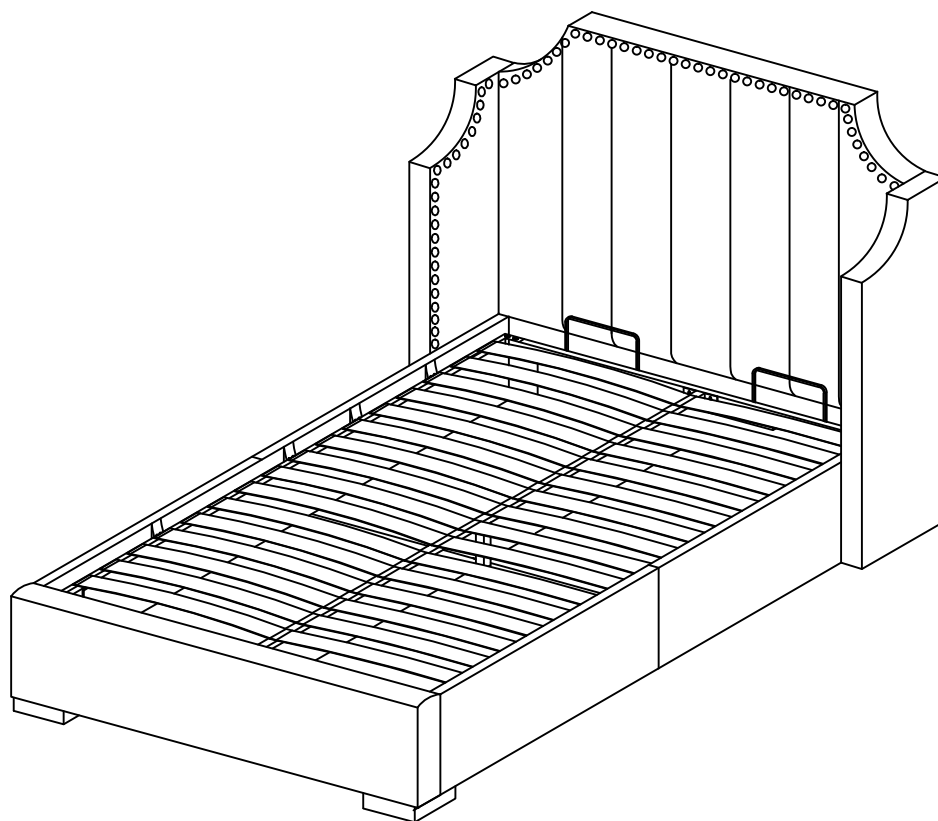

Meuble à usage domestique / Domestic furniture / Meuble a uso domestico / Möbel für den häuslichen Wohngebrauch/
Mobili per la casa/ Huishoudmeubilair / Mobiliário doméstico / Meble domowe

3666471105940
3666471105926

ROSE / LIGHT PINK
GRIS CLAIR / LIGHT GREY



1. Repérez les pièces constituant votre meuble.
2. Regroupez et comptez la quincaillerie.
3. Munissez-vous de l'outillage nécessaire.
4. Aménagez-vous une zone de montage, la moquette ou une couverture protégera des rayures.
5. Procédez au montage, ne jamais forcer sur les assemblages, resserrez les vis après quelques temps d'usage.



FR Gardez votre notice de montage.
Si une pièce venait à manquer elle sera le moyen le plus clair pour communiquer avec votre magasin.
Nous conseillons d'aérer la pièce lors du montage et quelques heures après.

1. Identify the parts which make up your piece of furniture.
2. Gather the hardware parts and count them.
3. Have the necessary tools ready.
4. Organize a space for assembly, wall carpeting or a blanket will protect the furniture against scratches.
5. Mount the furniture, never force the parts to be assembled.



EN Tighten the screws after it has been used for some time.
Keep the assembly instruction since it will help you when you get in touch with the store if a part should be missing.
We advise ventilating the room during installation and during few hours after.

1. Localice las piezas que componen su mueble.
2. Reagrupe y cuente la tornilleria.
3. Prepare las herramientas necesarias.
4. Prepare una zona de montaje, la moqueta o una manta protegerá de arañazo.
5. Proceda al montaje, no forzar sobre los embalages, apretar los tornillos después de algún tiempo de uso.



ES Guardar las instrucciones de montaje.
Si una pieza le faltase, sera la manera mas facil de comunicarse con su proveedor.
Aconsejamos ventilar la zona durante la instalación y algunas horas después.

1. Bitte überprüfen Sie, ob alle Einzelteile Ihres Möbelstücks vorhanden sind.
2. Bitte überprüfen Sie, ob alle Schrauben und Verbindungsteile für die Montage vorhanden sind.
3. Halten sie alle notwendigen Montage-Werkzeuge für ihren Einsatz gebrauchsbereit.
4. Bereiten Sie einen passenden Ort für die Montage vor. Ein Teppichboden oder ähnliches schützt vor Kratzern.
5. Beginnen Sie mit der Montage. Lassen Sie sich Zeit und fügen Sie die Einzelteile nie mit Gewalt zusammen.



DE Um einen langfristigen und einwandfreien Gebrauch zu gewährleisten, ziehen Sie die einzelnen Schrauben regelmäßig nach längerer Nutzung des Möbelstücks fest.

Bitte bewahren Sie diese Montageanleitung auf. Diese gewährleistet im Problemfall einen reibungslosen und schnellen Kommunikationsaustausch mit dem Kundenservice Ihres Geschäfts.

Wir beraten, lüften Sie den Raum während der Installation und ein paar Stunden später.

1. Identificare le parti che compongono il mobile.
2. Raccogliere le parti e contarle.
3. Tenere pronti gli attrezzi necessari.
4. Organizzare uno spazio per il montaggio, un telo da parete o una coperta proteggerà i mobili contro i graffi.
5. Montare il mobile, non forzare mai le parti da assemblare.



IT Serrare le viti dopo che sono state usate per un certo periodo di tempo.
Conservare le istruzioni di montaggio poiché vi torneranno utili quando ricontatterete il negozio se una parte dovesse mancare.
Si consiglia di ventilare la stanza durante l'installazione e durante le ore successive.

1. Identificeer de onderdelen waar uw stuk meubilair uit bestaat.
2. Verzamel de hardwareonderdelen en tel deze.
3. Heb het vereiste gereedschap bijdehand.
4. Organiseer een ruimte voor assemblage; muurtapijt of een deken zal het meubilair beschermen tegen krassen.
5. Monteer het meubilair en forceer hierbij nooit de te monteren onderdelen.



NL Draai de schroeven vast nadat het een tijdje in gebruik is geweest.
Bewaar de assemblage-instructies in het geval dat u contact op moet nemen met de winkel indien er een onderdeel ontbreekt.
Wij raden u aan de kamer te ventileren tijdens en voor enkele uren na de installatie.

1. Identifique as peças que constituem a sua mobília.
2. Junte as ferragens e conte.
3. Tenha prontas as ferramentas necessárias.
4. Organize e arranje espaço para a montagem, colocando um tapete ou manta para proteger a mobília contra riscos.
5. Monte a mobília, nunca force as peças a montar.



PT Aperte os parafusos após a peça de mobília ter sido utilizada durante algum tempo.
Guarde as instruções de montagem, pois serão úteis quando quiser contactar a loja, caso perca alguma peça.
Aconselhamos a ventilar a divisão durante a instalação e algumas horas depois.

1. Zidentyfikuj części, z których składa się Twój mebel.
2. Zbierz części i policz je.
3. Przygotuj niezbędne narzędzia.
4. Zorganizuj przestrzeń do montażu; wykładzina lub koc zabezpieczy meble przed zarysowaniami.
5. Zamontuj meble; nigdy nie montuj części na siłę.



PL Dokręć śruby po pewnym czasie użytkowania.
Zachowaj instrukcję montażu, ponieważ pomoże ci ona w kontakcie ze sklepem, jeśli brakuje części.
Zalecamy przewietrzenie pomieszczenia podczas instalacji oraz kilka godzin po jej zakończeniu.

**IMPORTANT, A CONSERVER POUR UNE
REFERENCE ULTERIEURE: LIRE
ATTENTIVEMENT**

**IMPORTANT, RETAIN FOR FUTURE REFERENCE:
READ CAREFULLY**

**IMPORTANTE, CONSERVAR PARA FUTURAS
CONSULTAS: LEER ATENTAMENTE**

**WICHTIG, FÜR SPÄTERES NACHSCHLAGEN
AUFBEWAHREN: SORGFÄLTIG LESEN**

**IMPORTANTE, CONSERVARE PER RIFERIMENTO
FUTURO, LEGGERE CON ATTENZIONE**

**BELANGRIJK, BEWAARALS EVENTUEEL
NASLAGWERK, ZORGVULDIG LEZEN**

**IMPORTANTE, GUARDAR PARA REFERÊNCIA
FUTURA, LER ATENTAMENTE**

**WAŻNE, ZACHOWAJ NA PRZYSZŁOŚĆ: PRZECZYTAJ
UWAŻNIE**

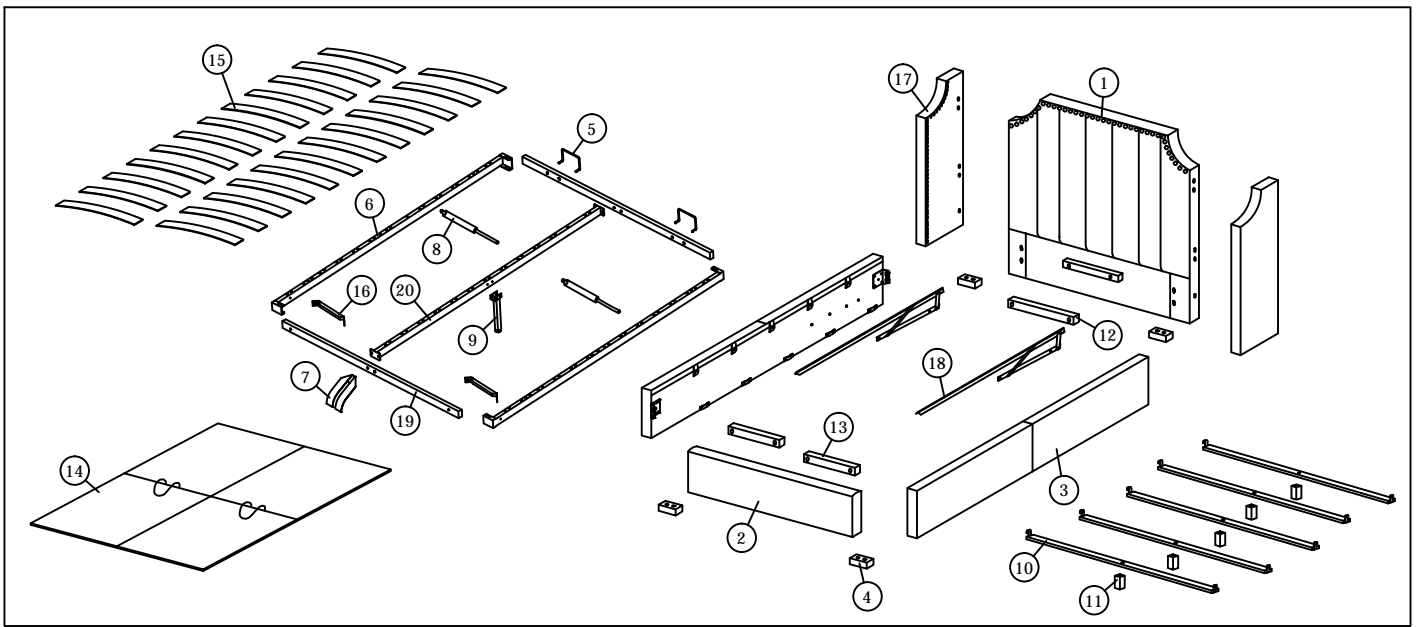

TOOLS

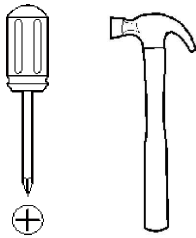

No.	Tamaño	Cant	Cnt No.
1	1525 x 1085 x 120mm	1	1
2	1525 x 310 x 60mm	1	2
3	1900 x 310 x 30mm	2	2
4	150 x 60 x 45mm	4	4
5	192 x 135 x 8mm	2	2
6	1864 x 50.4 x 25.4mm	2	2
7	555 x 40mm	1	2
8	545 x 20mm	2	4
9	233 x 25.4 x 25.4mm	1	2
10	1380 x 65 x 20mm	5	4
11	38 x 38 x 33mm	5	4

No.	Tamaño	Cant	Cnt No.
12	450 x 40 x 30mm	1	4
13	300 x 40 x 30mm	2	4
14	945 x 686 x 9mm	4	3
15	675 x 63 x 9mm	24	4
16	165 x 12 x 12mm	2	2
17	1020 x 240 x 38mm	2	1
18	1520 x 170mm	2	2
19	1307 x 50.4 x 25.4mm	2	2
20	1810 x 50.4 x 25.4mm	1	2

101		X5
M6 x 30mm		

102		X6
M6 x 40mm		

103		X6
M6 x 70mm		

104		X12
M8 x 40mm		

105		X6
M6 FLAT WASHER		

106		X4
M8 SPRING WASHER		

107		X4
M8 FLAT WASHER		

108		X8
M4 x 20mm		

109		X4
M8 x 30mm		

110		X24
BED SLAT SIDE FITTER		

111		X12
BED SLAT CENTER FITTER		

112		X1
M4 ALLEN KEY		

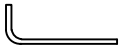
113		X1
		
M5 ALLEN KEY		

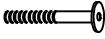
114		X6
		
M6 x 40mm (BLACK)		

115		X4
		
M8 x 40mm (BLACK)		

116		X8
		
M8 x 70mm (BLACK)		

117		X6
		
M6 FLAT WASHER (BLACK)		

118		X6
		
M6 SPRING WASHER (BLACK)		

119		X16
		
M8 FLAT WASHER (BLACK)		

120		X16
		
M8 SPRING WASHER (BLACK)		

121		X6
		
M6 HEX NUT (BLACK)		

122		X16
		
M8 HEX NUT (BLACK)		

123		X1
		
SPANNER (10mm)		

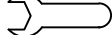
124		X1
		
SPANNER (13mm)		

125		X2
		
SPECIAL HEX NUT		

126		X4
		
M8 x 20mm		

127		X2
		
M8 x 70mm		

128		X8
		
M8 PLASTIC COVER		

129		X4
		
PLASTIC WASHER		

1

Take out HEADBOARD WING (17) from the HEABBOARD (1).

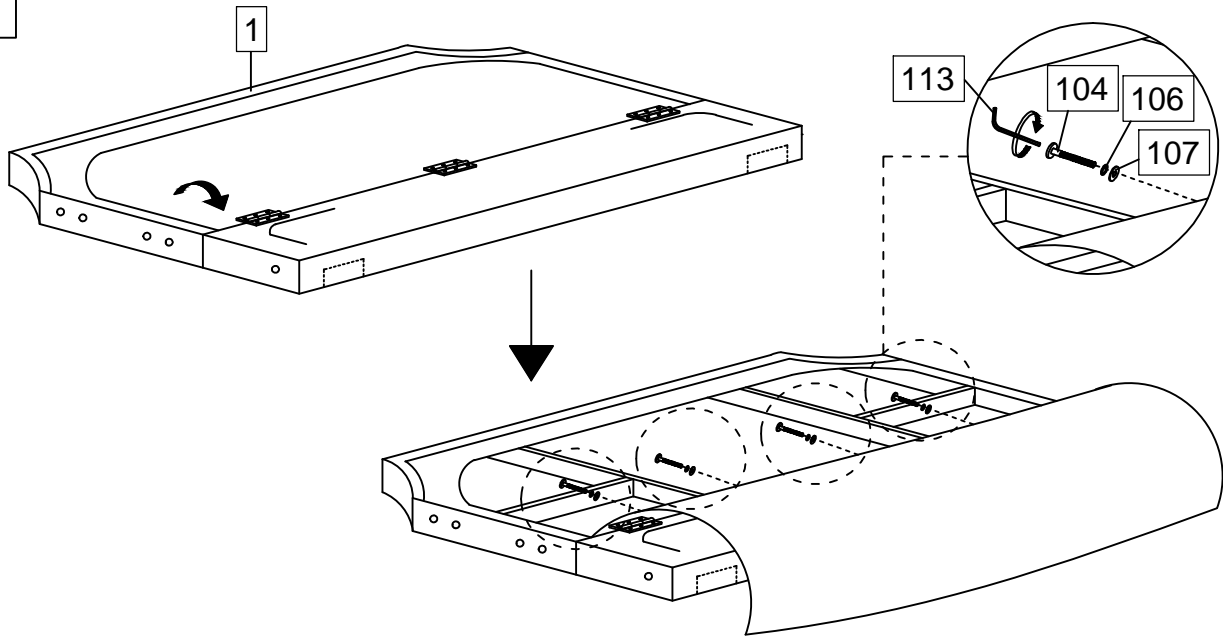

104		X4
		
M8 x 40mm		

106		X4
		
M8 SPRING WASHER		

107		X4
		
M8 FLAT WASHER		

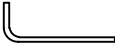
113		X1
		
M5 ALLEN KEY		

2

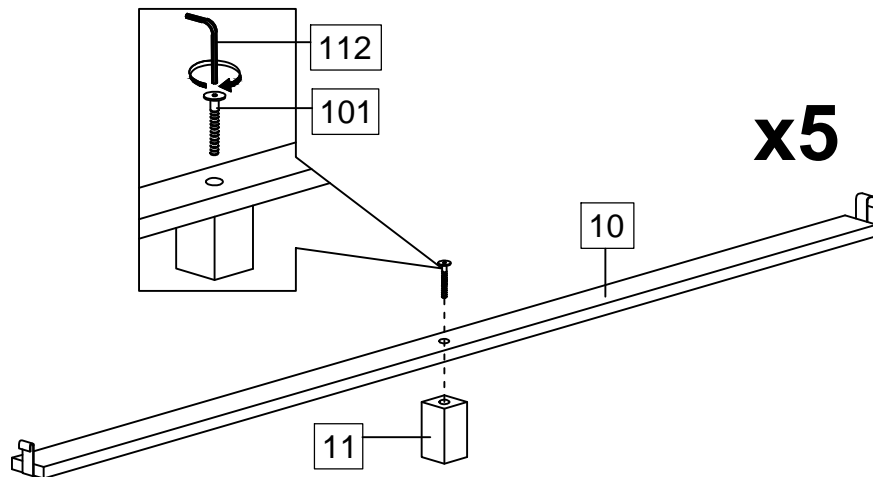

101		X5
		
M6 x 30mm		

112		X1
		
M4 ALLEN KEY		

3

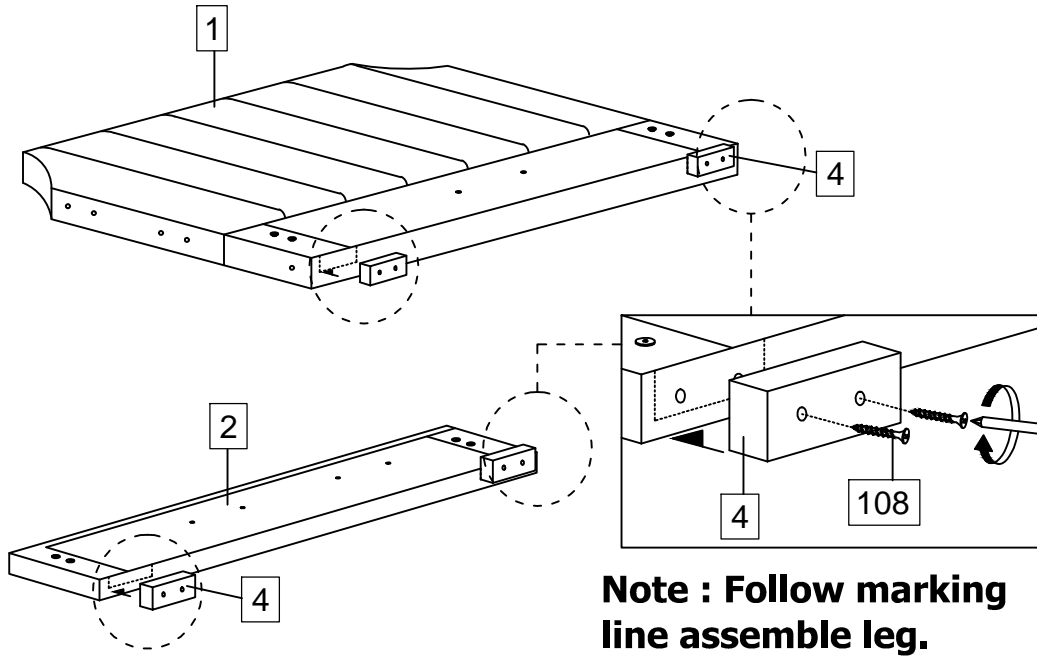

108		X8
		
M4 x 20mm		

4

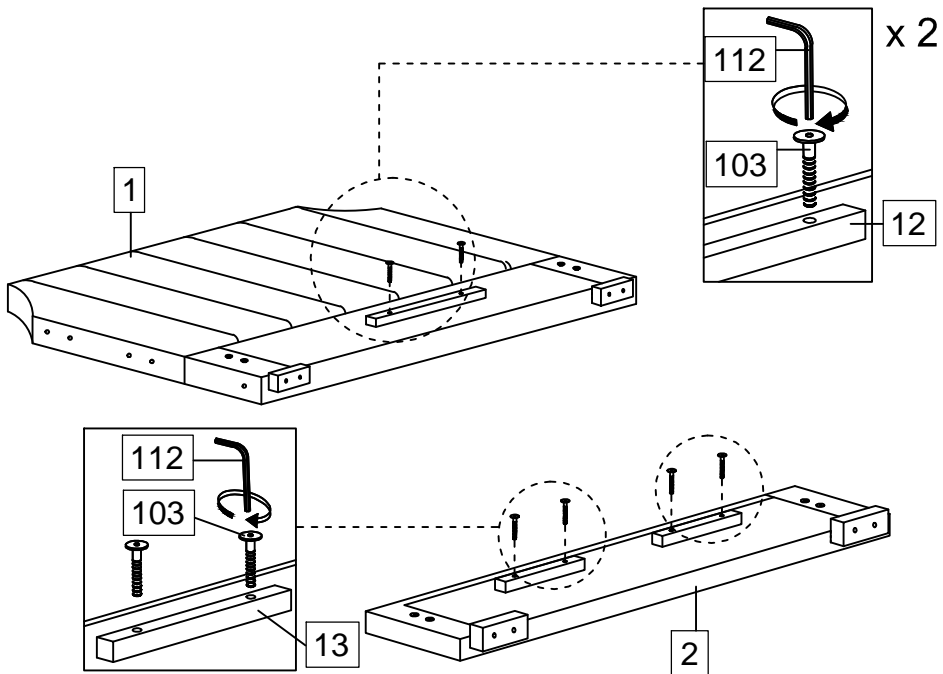

103		X6
		
M6 x 70mm		

112		X1
		
M4 ALLEN KEY		

5

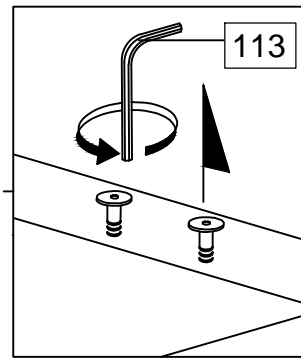
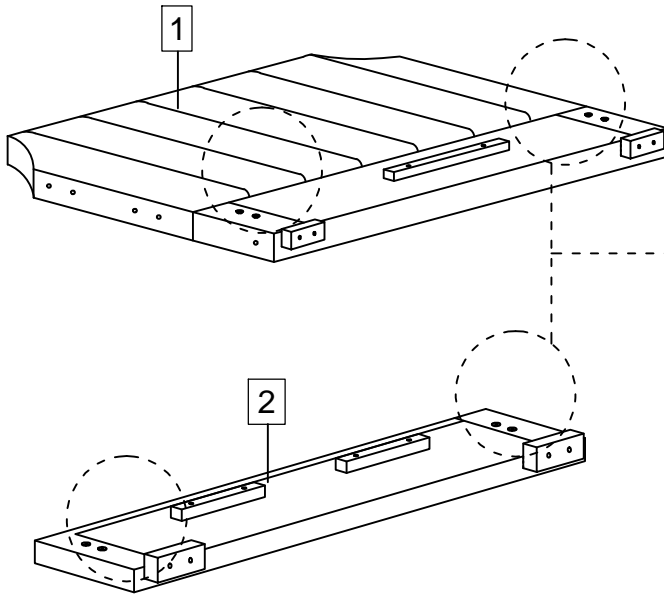

Loosen the pre-inserted bolt on the headboard and footboard using Allen key ball shape (113).

113		X1
M5 ALLEN KEY		

6

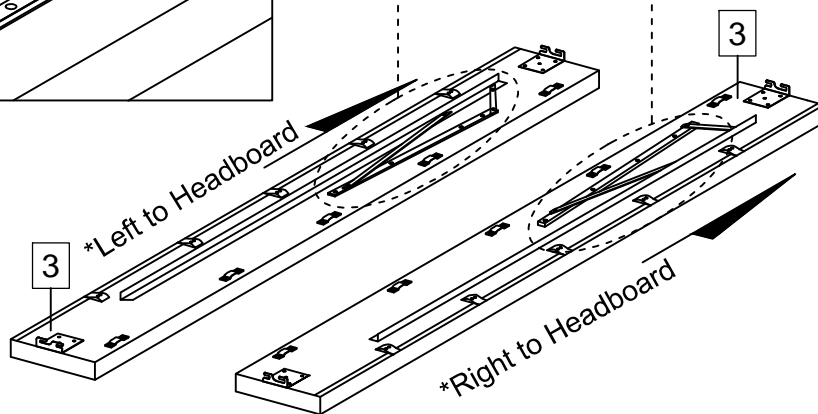
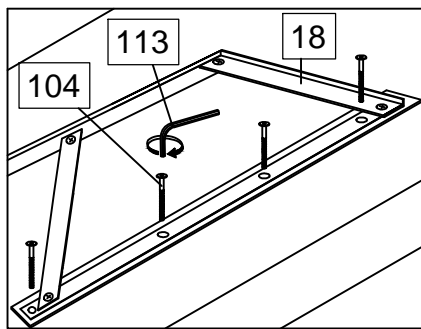

104		X8
M8 x 40mm		

113		X1
M5 ALLEN KEY		

7

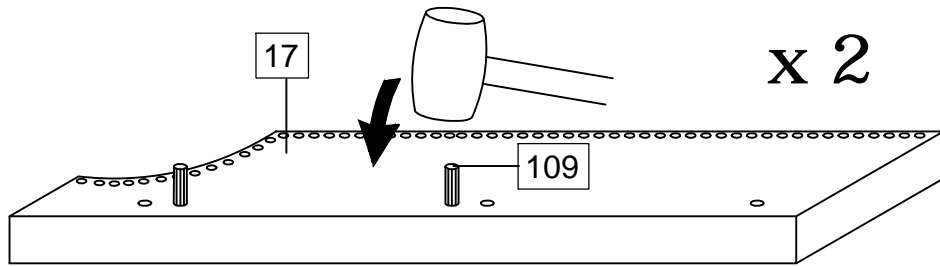

109		X4
M8 x 30mm		

8

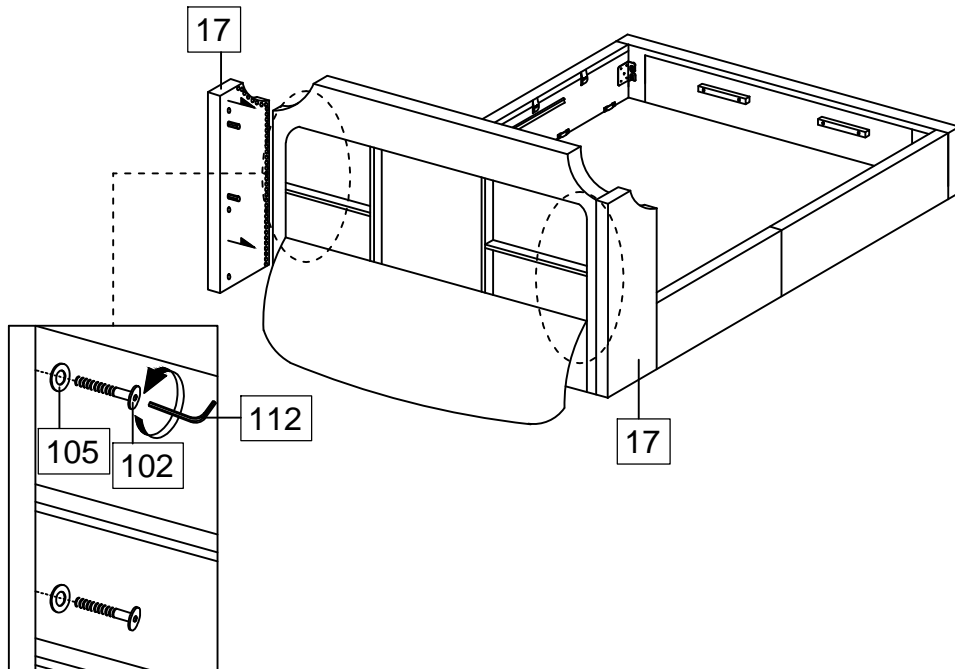



102		X4
M6 x 40mm		

105		X4
M6 FLAT WASHER		

112		X1
M4 ALLEN KEY		

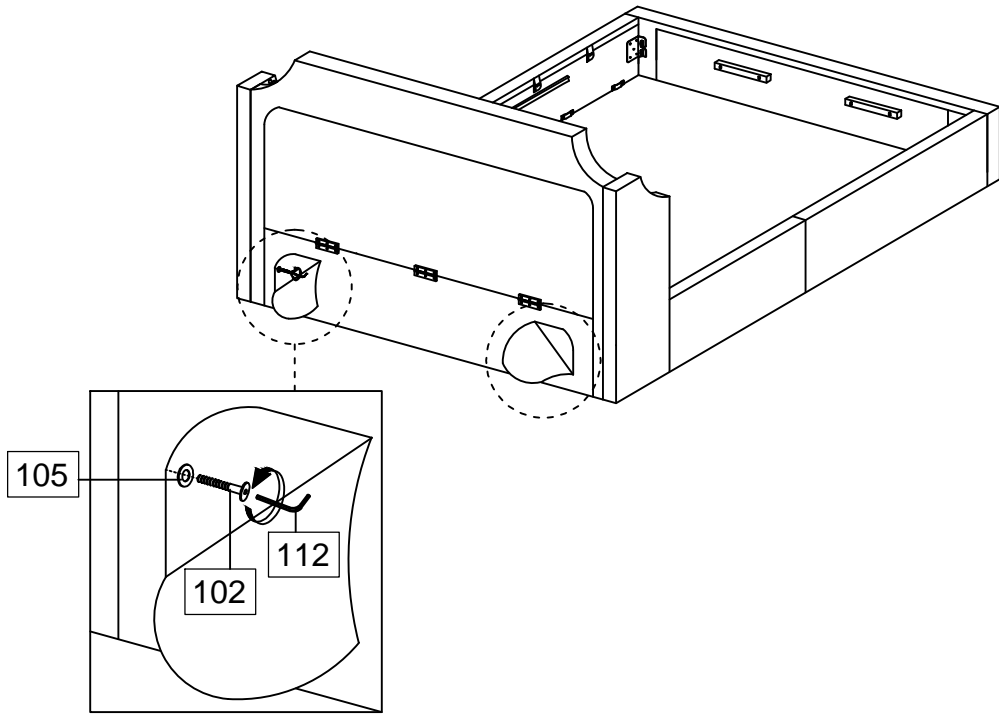
9



102		X2
		
M6 x 40mm		

105		X2
		
M6 FLAT WASHER		

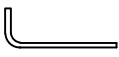
112		X1
		
M4 ALLEN KEY		

10

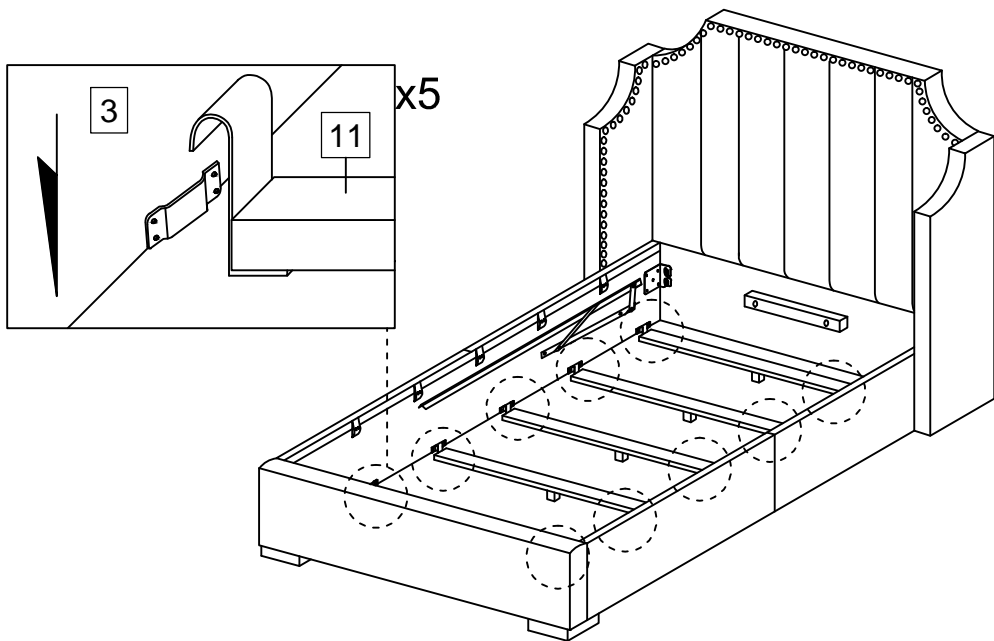

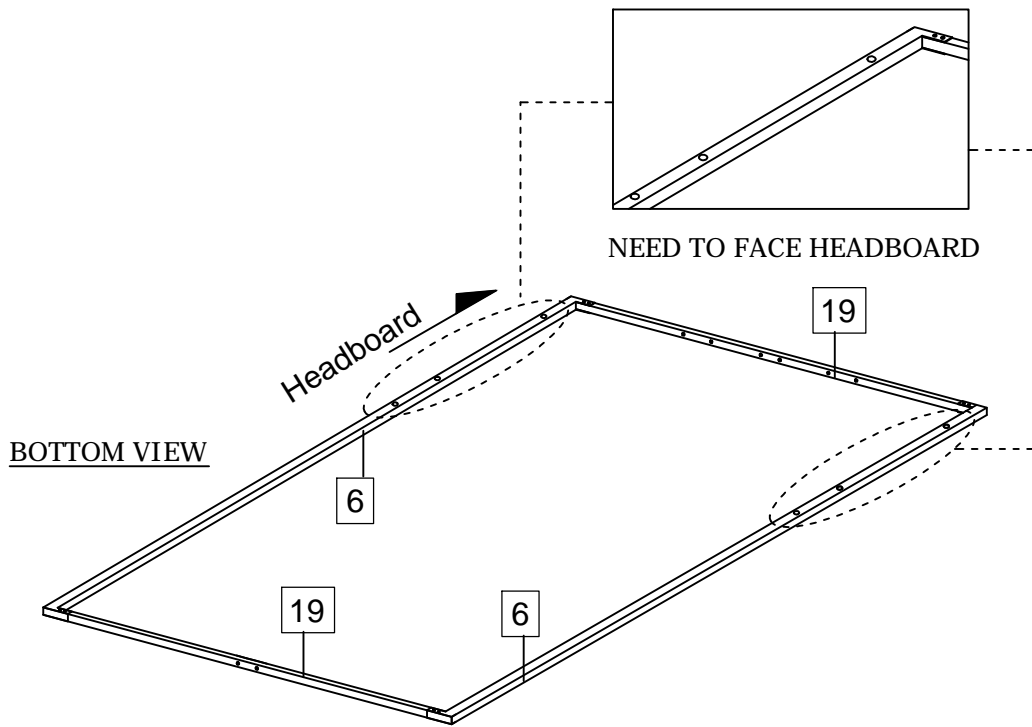

11



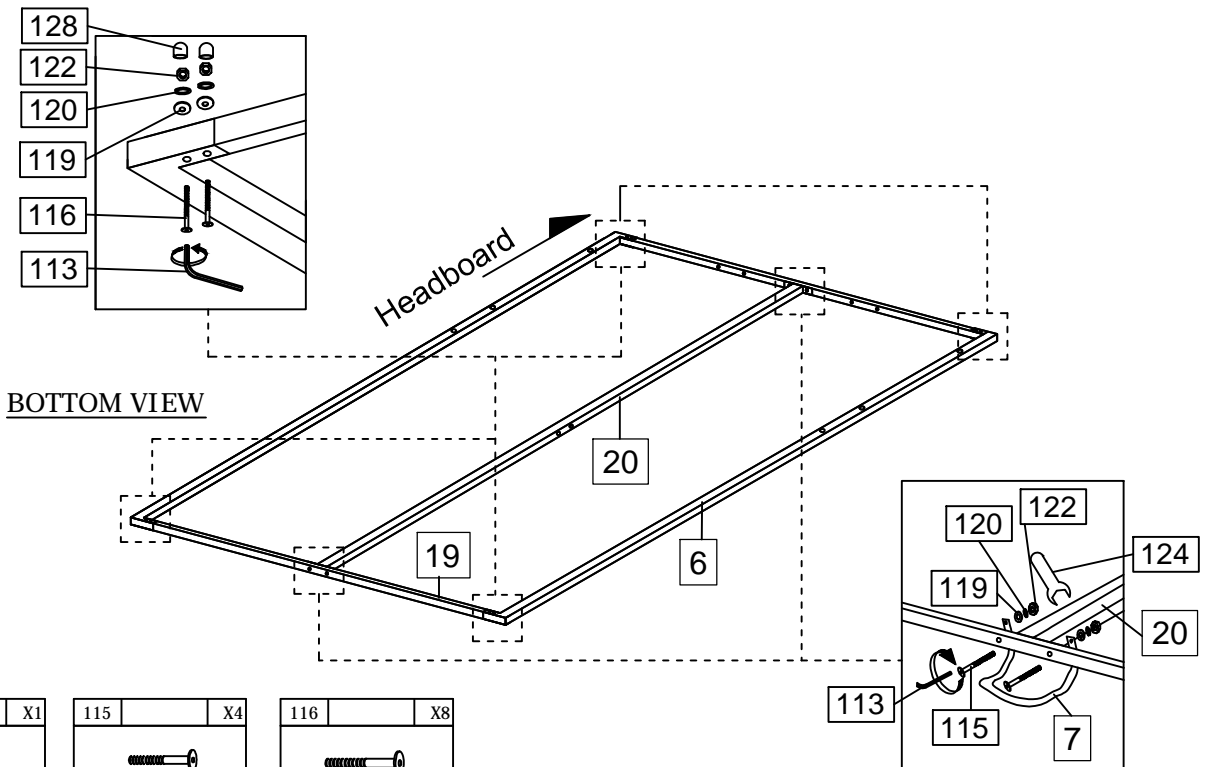

12





113	X1
	
M5 ALLEN KEY	

115	X4
	
M8 x 40mm (BLACK)	

116	X8
	
M8 x 70mm (BLACK)	

119	X12
	
M8 FLAT WASHER (BLACK)	

120	X12
	
M8 SPRING WASHER (BLACK)	

122	X12
	
M8 HEX NUT (BLACK)	

128	X8
	
M8 PLASTIC COVER	

124	X1
	
SPANNER (13mm)	

13

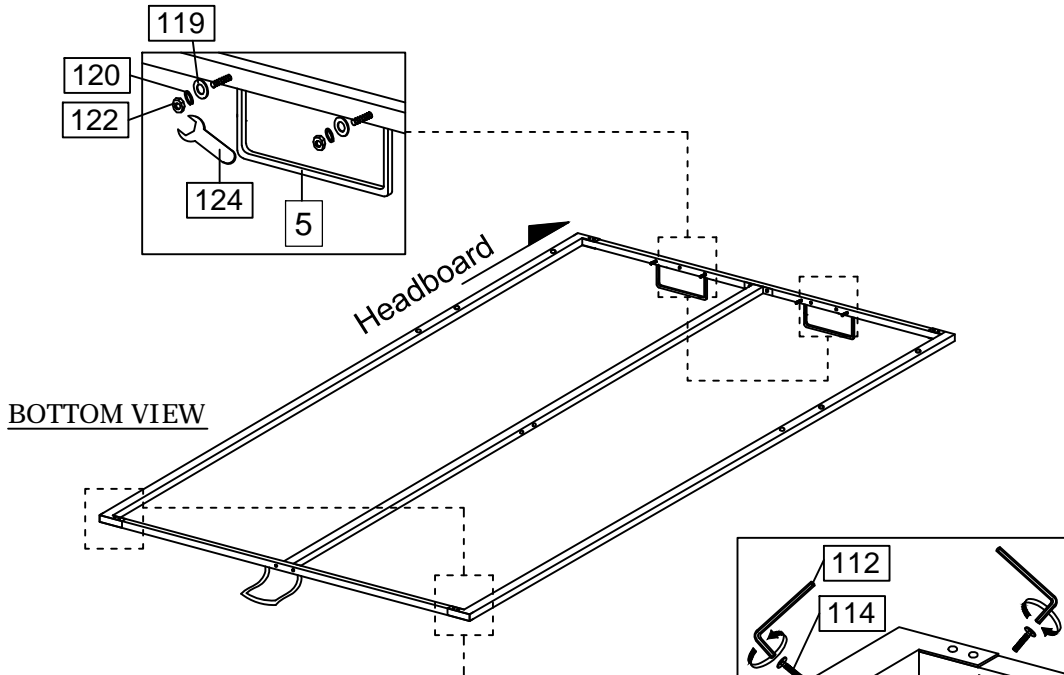

112		X1
M4 ALLEN KEY		

114		X4
M6 x 40mm (BLACK)		

117		X4
M6 FLAT WASHER (BLACK)		

118		X4
M6 SPRING WASHER (BLACK)		

121		X4
M6 HEX NUT (BLACK)		

119		X4
M8 FLAT WASHER (BLACK)		

120		X4
M8 SPRING WASHER (BLACK)		

122		X4
M8 HEX NUT (BLACK)		

123		X1
SPANNER (10mm)		

124		X1
SPANNER (13mm)		

14

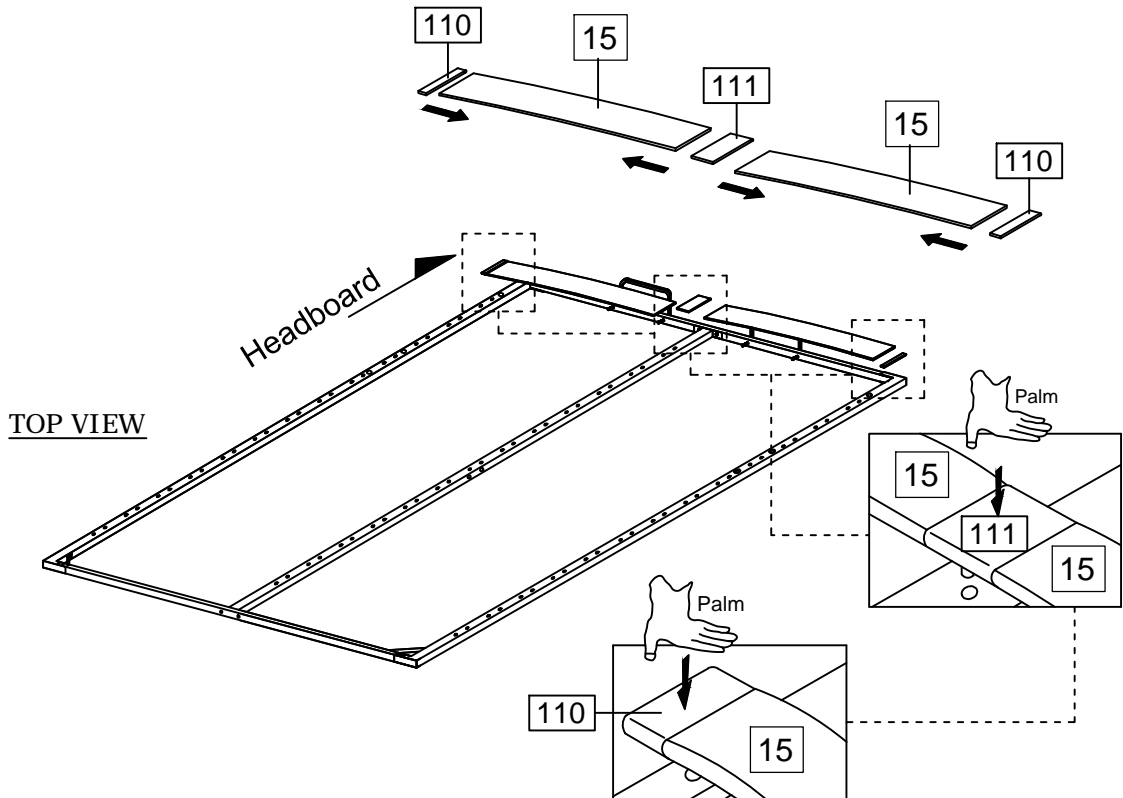

110		X24
BED SLAT SIDE FITTER		

111		X12
BED SLAT CENTER FITTER		

15

Attention :

A person need to hold up the metal frame from footboard side, and the other person assemble the gas spring (Item 8).

Loosen the pre-inserted Special Hex Nut on the Gas Spring Metal (18) using Spanner 13mm (124).

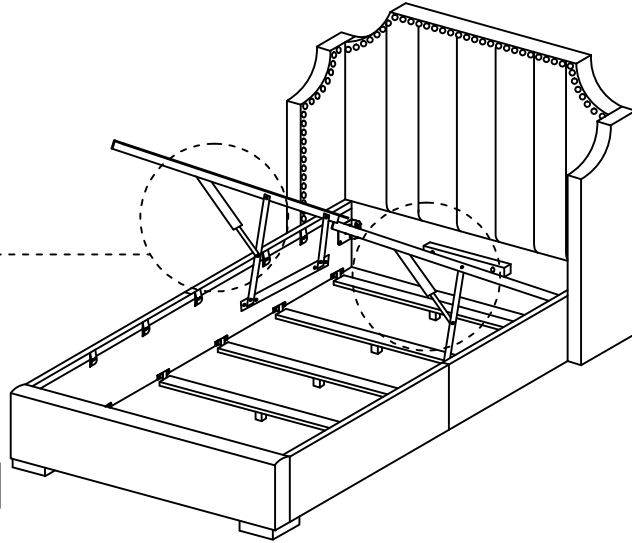
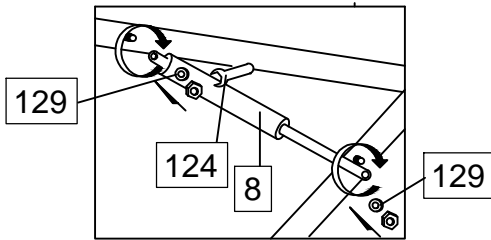
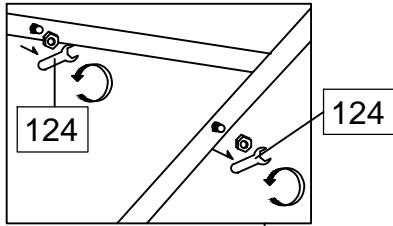

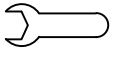
124		X1
		
SPANNER (13mm)		

129		X4
		
PLASTIC WASHER		

16

Note : This step requires two people.

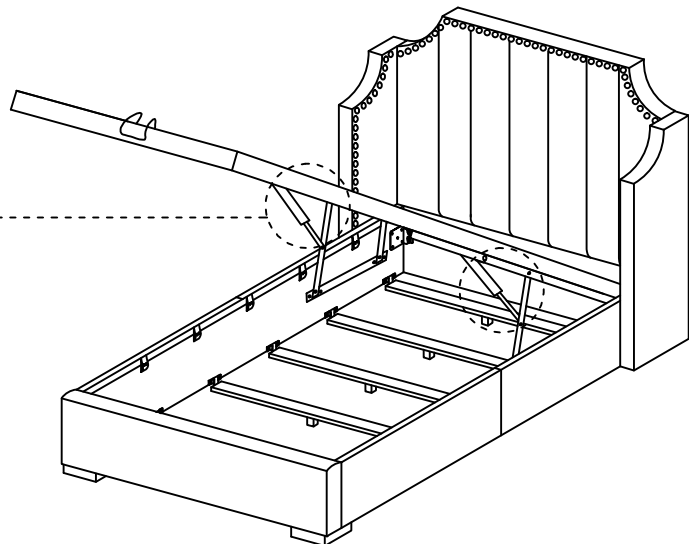
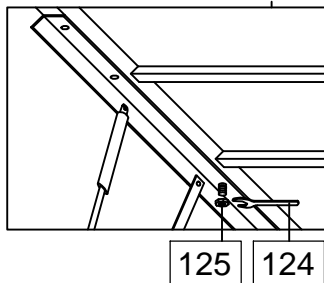
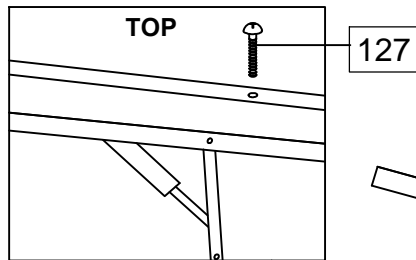

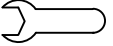
124		X1
		
SPANNER (13mm)		

125		X2
		
SPECIAL HEX NUT		

127		X2
		
M8 x 70mm		

17

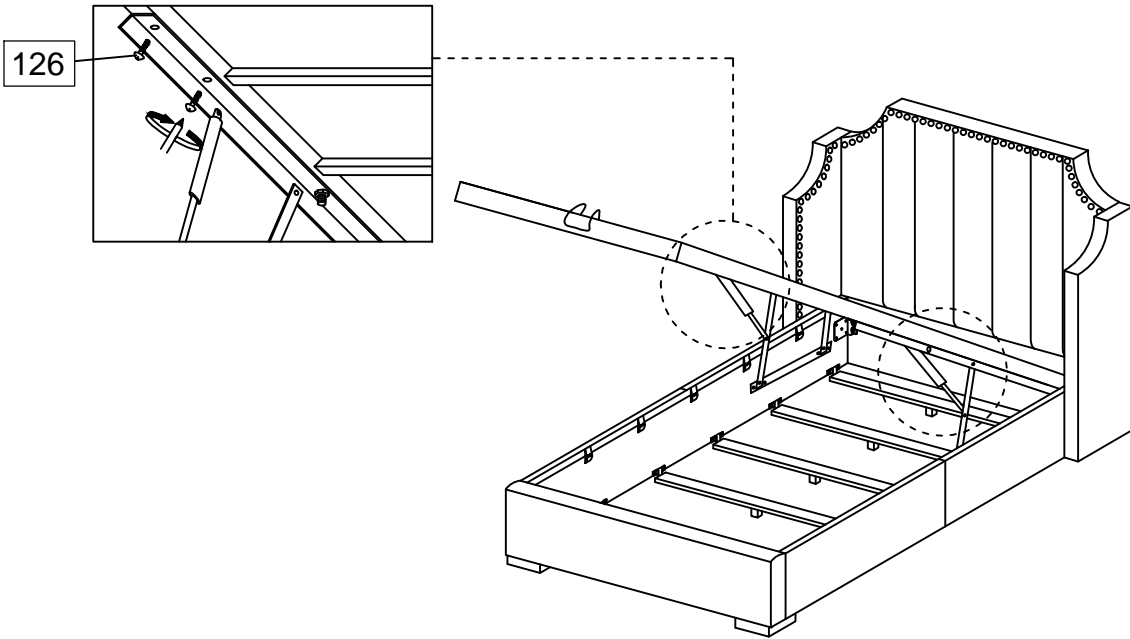

126		X4
M8 x 20mm		

18

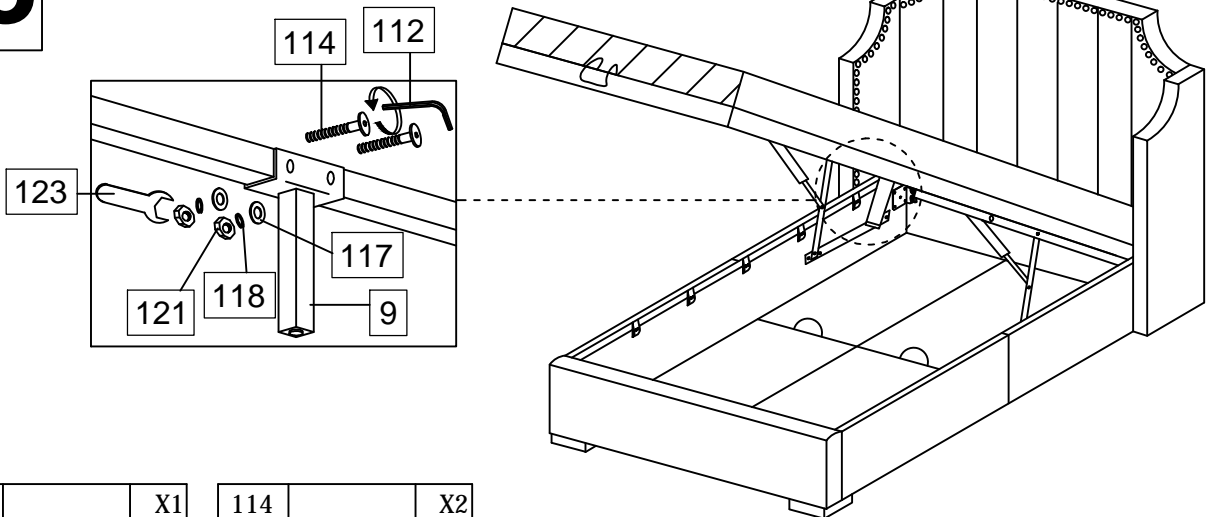

112		X1
M4 ALLEN KEY		

114		X2
M6 x 40mm (BLACK)		

117		X2
M6 FLAT WASHER (BLACK)		

118		X2
M6 SPRING WASHER (BLACK)		

121		X2
M6 HEX NUT (BLACK)		

123		X1
SPANNER (10mm)		

19

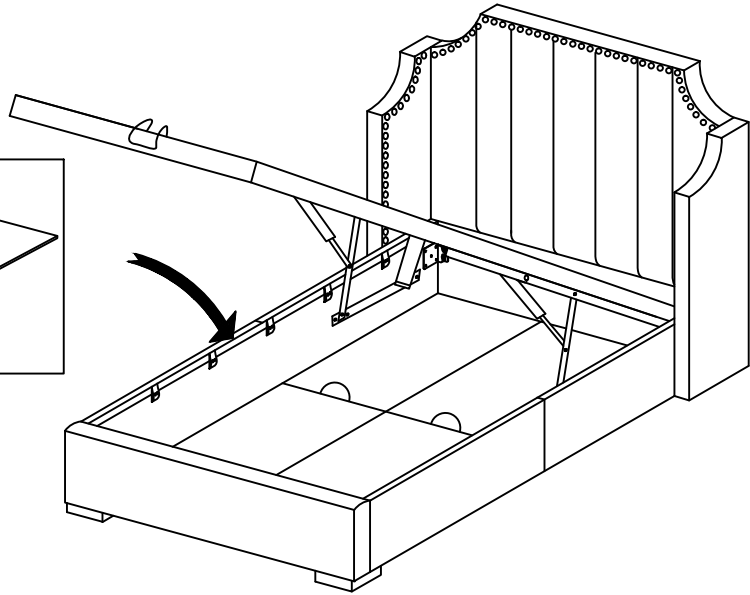
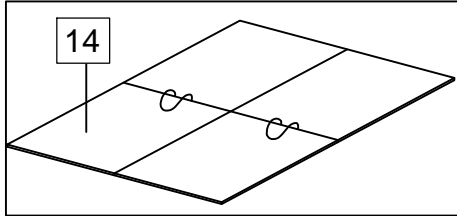

20

Attention :

1. This **full** size bed supports mattress weight 40 - 65kgs.

2. Place your mattress onto the bed frame **BEFORE** closing or this could result in damage to the bed (MATTRESS NOT INCLUDED) .

3. It is imperative that the bed is aligned squarely to prevent the frame from catching on and damaging the upholstered side rails

Please use extra caution when opening and closing the bed for the first few times.

Ensure a similar spacing on each side of the frame.

Ensure open and close the bed frame thru center of bed by using PP tape on center of metal frame.

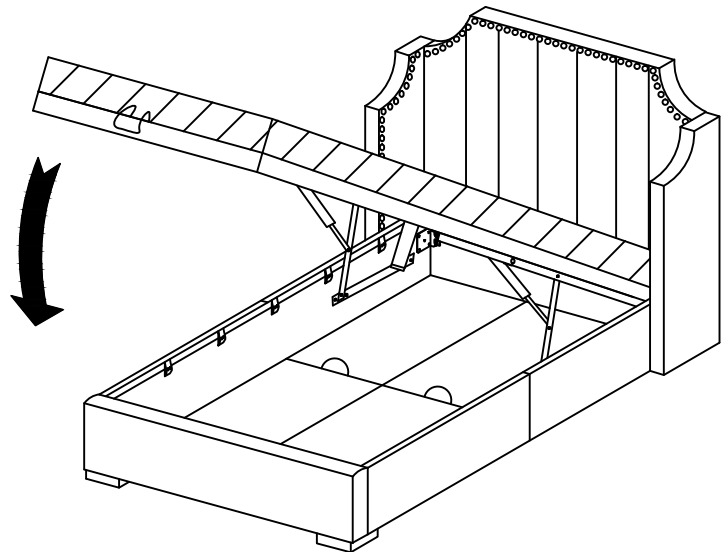

Entretien et maintenance:

Dépoussiérer régulièrement avec un chiffon sec.

Nettoyer avec du liquide vaisselle et essuyer avec un chiffon humide.

Ne pas utiliser le produit si l'un des éléments semble endommagé, brisé ou manque.

Eviter de placer ce produit à proximité de feu ouvert et d'autres sources de forte chaleur telle qu'un radiateur.

Care and maintenance:

Remove dust regularly with a dry cloth.

Clean with dishwashing liquid and wipe with a damp cloth.

Do not use the product if any part appears damaged, broken or missing.

Be aware of the risk of open fire and other sources of strong heat, such as electric heaters, in the vicinity of the product.

Cuidado y mantenimiento:

Quite el polvo periódicamente con un paño seco.

Limpiar con líquido para lavar platos y limpiar con un paño húmedo.

No utilice el producto si alguna de las piezas está dañada, rota o falta.

Conozca los riesgos de un fuego y de otras fuentes de calor fuerte, como los calefactores eléctricos, en las proximidades del producto.

Pflege und Wartung:

Entfernen Sie den Staub regelmäßig mit einem trockenen Tuch.

Reinigen Sie mit Spülmittel und wischen Sie mit einem feuchten Tuch.

Verwenden Sie das Produkt nicht, wenn Teile beschädigt, defekt sind oder fehlen.

Achten Sie auf die Gefahr von Feuer und anderen starken Wärmequellen in der Nähe des Produkts, wie elektrische Heizkörper.

Cura e manutenzione:

Rimuovere la polvere regolarmente con un panno asciutto.

Pulire con detersivo per piatti e asciugare con un panno umido.

Non utilizzare il prodotto se una parte risulta danneggiata, rotta o mancante.

Essere consapevoli del rischio rappresentato da un camino e da altre fonti di forte calore, come riscaldatori elettrici, in prossimità del prodotto.

Onderhoud en reiniging:

Verwijder regelmatig enigerlei stof met een droge doek.

Reinig met afwasmiddel en veeg af met een vochtig doekje.

Gebruik het product niet als enigerlei onderdelen beschadigd lijken, gebroken zijn of ontbreken.

Houd rekening met de risico's van open vuur en andere krachtige hittebronnen, zoals elektrische verwarmingen, in de buurt van het product.

Cuidado e manutenção:

Remova frequentemente a poeira com um pano seco.

Limpe com detergente da loiça e um pano humedecido.

Não utilize o produto se alguma peça parecer danificada, partida ou em falta.

Tenha em atenção o risco de chama viva e de outras fontes de calor forte, como aquecedores elétricos, perto do produto.

Czyszczenie i konserwacja:

Regularnie usuwaj kurz suchą szmatką.

Wyczyść płynem do mycia naczyń i wytrzyj wilgotną szmatką.

Nie używaj produktu, jeśli jakkolwiek części brakuje, wygląda na uszkodzoną, zepsutą.

W pobliżu produktu należy unikać używania otwartego ognia oraz innych źródeł dużego ciepła jak grzejniki elektryczne..

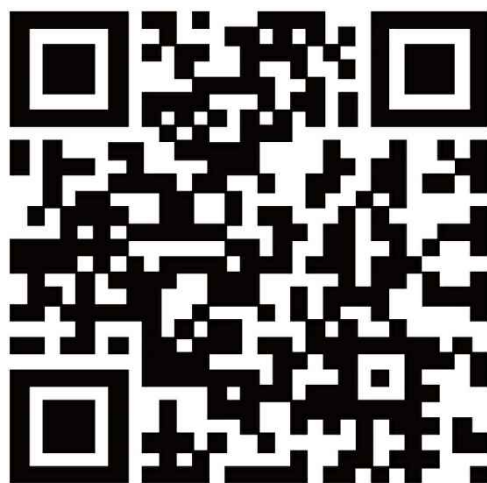

VS-03-Apr-2024
Imported by - Importé par
CAFOM DISTRIBUTION
9 Rue Jacquart 93310 Le Pré-Saint-Gervais
Made in Malaysia/ Fabriqué en Malaisie