

Montageanleitung | Instructions de montage Assembly Instructions | Instrucciones de montaje

SKU NUMBER: N616P430131/N616P430132/N616P430133/N616P430134

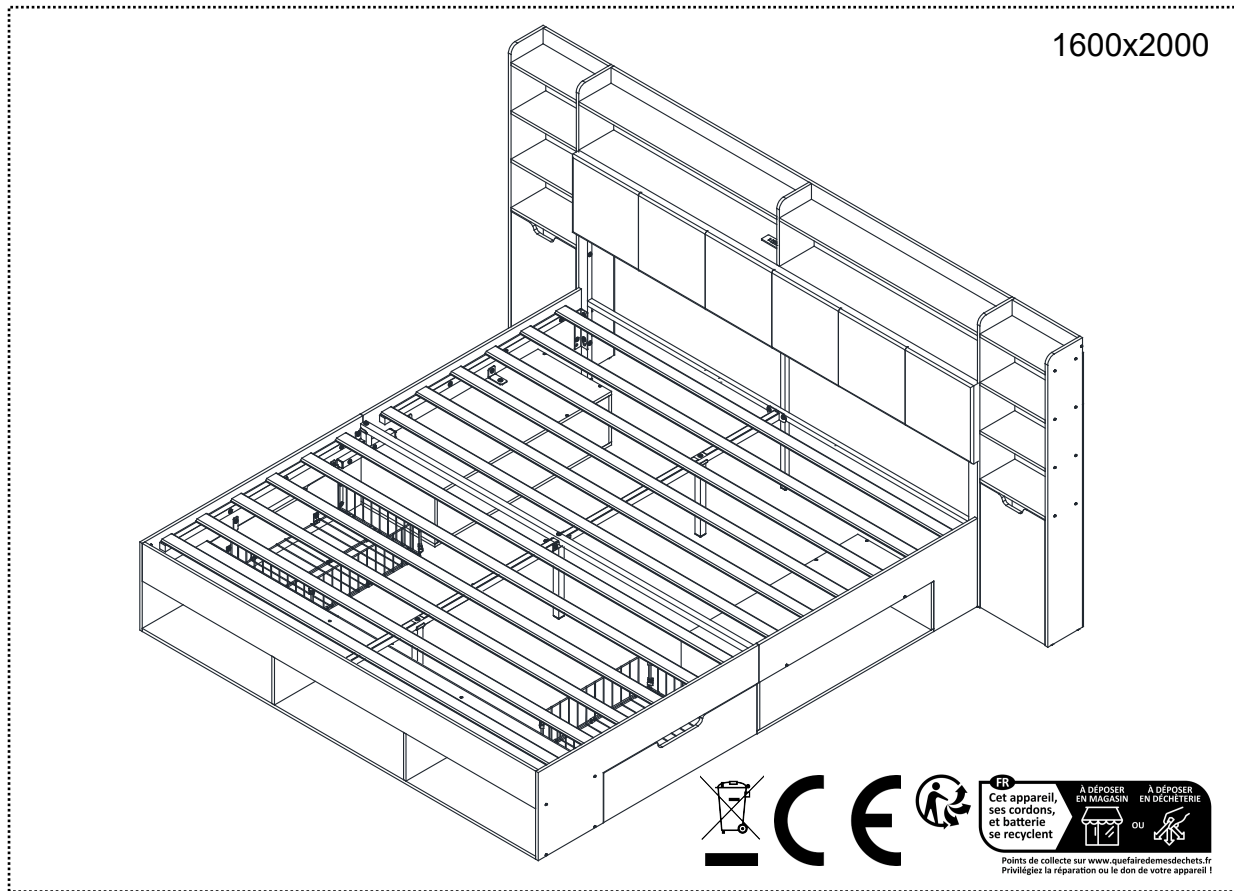

- DE** Unser Produkt wird Ihnen in 4 Paketen geliefert. Die Lieferzeiten dieser 4 Pakete können abweichen, bitte haben Sie etwas Geduld und vielen Dank für Ihr Verständnis.
- UK** Our product will be delivered to you in 4 packages. The delivery times of these 4 packages may differ, please be patient and thank you for your understanding.
- FR** Notre produit vous sera livré en 4 colis. Les délais de livraison de ces 4 colis peuvent différer, soyez patient et merci pour votre compréhension.
- IT** Il nostro prodotto verrà consegnato in 4 pacchi. I tempi di consegna di questi 4 pacchi possono variare; vi preghiamo di avere un po' di pazienza e vi ringraziamo per la vostra comprensione.
- ES** Nuestro producto se entregará en 4 paquetes. Los tiempos de entrega de estos 4 paquetes pueden variar; por favor, tenga un poco de paciencia y gracias por su comprensión.
- NL** Ons product wordt in 4 pakketten bij u geleverd. De levertijden van deze 4 pakketten kunnen verschillen, we vragen om uw geduld en bedanken u voor uw begrip.
- SE** Vår produkt kommer att levereras till dig i 4 paket. Leveranstiderna för dessa 4 paket kan variera, vi ber om ditt tålamod och tackar för din förståelse.
- PL** Nasz produkt zostanie dostarczony w 4 paczkach. Czas dostawy tych 4 paczek może się różnić, prosimy o cierpliwość i dziękujemy za zrozumienie.

English

IMPORTANT ! KEEP FOR FUTURE REFERENCE : READ CAREFULLY

- To be assembled by an adult. Assembly must be checked by an adult before use
- WARNING ! Keep all screws, small parts and plastic bags out of the reach of children
- Properly identify all parts before assembling
- Never use your item if any of its parts are broken or missing
- Should any problems arise, please contact our After Sales Service
- Manufacturer's instructions shall be followed at all times
- Care: Clean with a soft, dry cloth. In case of larger stains, carefully rub with a slightly damp, non-abrasive sponge
- Avoid the risk of fire by not placing furniture near sources of ignition or hot items
- Do not jump on the bed

Deutsch

WICHTIG ! ZUM SPÄTEREN NACHSCHLAGEN AUFBEWAHREN: SORGFÄLTIG LESEN

- Muss von einem Erwachsenen zusammengebaut werden. Der Zusammenbau muss vor dem Gebrauch von einem Erwachsenen überprüft werden
- WARNUNG! Bewahren Sie alle Schrauben, Kleinteile und Plastikbeutel außerhalb der Reichweite von Kindern auf
- Kennzeichnen Sie vor dem Zusammenbau alle Teile richtig
- Benutzen Sie Ihren Artikel niemals, wenn Teile gebrochen sind oder fehlen
- Sollten Probleme auftreten, wenden Sie sich bitte an unseren Kundendienst
- Die Anweisungen des Herstellers sind stets zu befolgen
- Pflege: Mit einem weichen, trockenen Tuch reinigen. Bei größeren Flecken vorsichtig mit einem leicht feuchten, nicht scheuernden Schwamm abreiben. nicht scheuernden Schwamm
- Vermeiden Sie die Gefahr eines Brandes, indem Sie die Möbel nicht in der Nähe von Zündquellen oder heißen Gegenständen aufstellen
- Nicht auf das Bett springen

Français

IMPORTANT ! CONSERVER POUR RÉFÉRENCE ULTÉRIEURE : LIRE ATTENTIVEMENT

- Le montage doit être effectué par un adulte. Le montage doit être vérifié par un adulte avant Utilisation
- ATTENTION ! Tenir les vis, les petites pièces et les sachets en plastique hors de portée des enfants
- Identifiez correctement toutes les pièces avant de les assembler
- N'utilisez jamais votre article si l'une de ses pièces est cassée ou manquante
- En cas de problème, veuillez contacter notre service après-vente
- Les instructions du fabricant doivent être respectées à tout moment
- Entretien : nettoyer avec un chiffon doux et sec. En cas de taches plus importantes, frotter soigneusement avec une éponge non abrasive légèrement humide. légèrement humide et non Abrasive
- Évitez les risques d'incendie en ne plaçant pas les meubles à proximité de sources d'inflammation ou d'objets chauds
- Ne pas sauter sur le lit

Italiano

IMPORTANTE! CONSERVARE PER RIFERIMENTO FUTURO: LEGGERE ATTENTAMENTE

- Deve essere assemblato da un adulto. L'assemblaggio deve essere controllato da un adulto prima dell'uso
- **ATTENZIONE!** Tenere tutte le viti, le piccole parti e i sacchetti di plastica fuori dalla portata dei bambini
- Identificare correttamente tutte le parti prima dell'assemblaggio
- Non utilizzare mai l'articolo se alcune parti sono rotte o mancanti
- In caso di problemi, si prega di contattare il nostro Servizio Post Vendita
- Le istruzioni del produttore devono essere sempre seguite
- Cura: Pulire con un panno morbido e asciutto. In caso di macchie più estese, strofinare accuratamente con una spugna leggermente umida e nonspugna leggermente umida e non abrasiva
- Evitare il rischio di incendio, non collocando i mobili vicino a fonti di accensione o a oggetti caldi
- Non saltare sul letto

Español

¡ IMPORTANTE ! CONSERVELO PARA FUTURAS CONSULTAS: LEA ATENTAMENTE

- Debe ser montado por un adulto. El montaje debe ser comprobado por un adulto antes del uso
- ADVERTENCIA Mantenga todos los tornillos, piezas pequeñas y bolsas de plástico fuera del alcance de los niños.
- Identifique correctamente todas las piezas antes de montarlas
 - Nunca utilice su artículo si alguna de sus piezas está rota o falta
 - Si surge algún problema, póngase en contacto con nuestro Servicio Postventa
 - Las instrucciones del fabricante deben seguirse en todo momento
 - Cuidado: Limpiar con un paño suave y seco. En caso de manchas más grandes, frote cuidadosamente con una esponja no abrasiva ligeramente humedecida.
 - Evite el riesgo de incendio no colocando los muebles cerca de fuentes de ignición u objetos calientes.
 - No saltar sobre la cama.

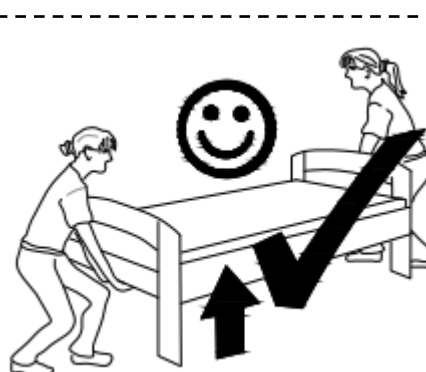
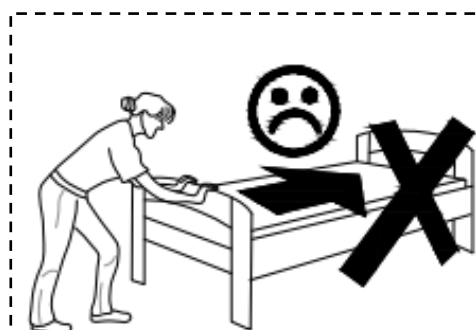

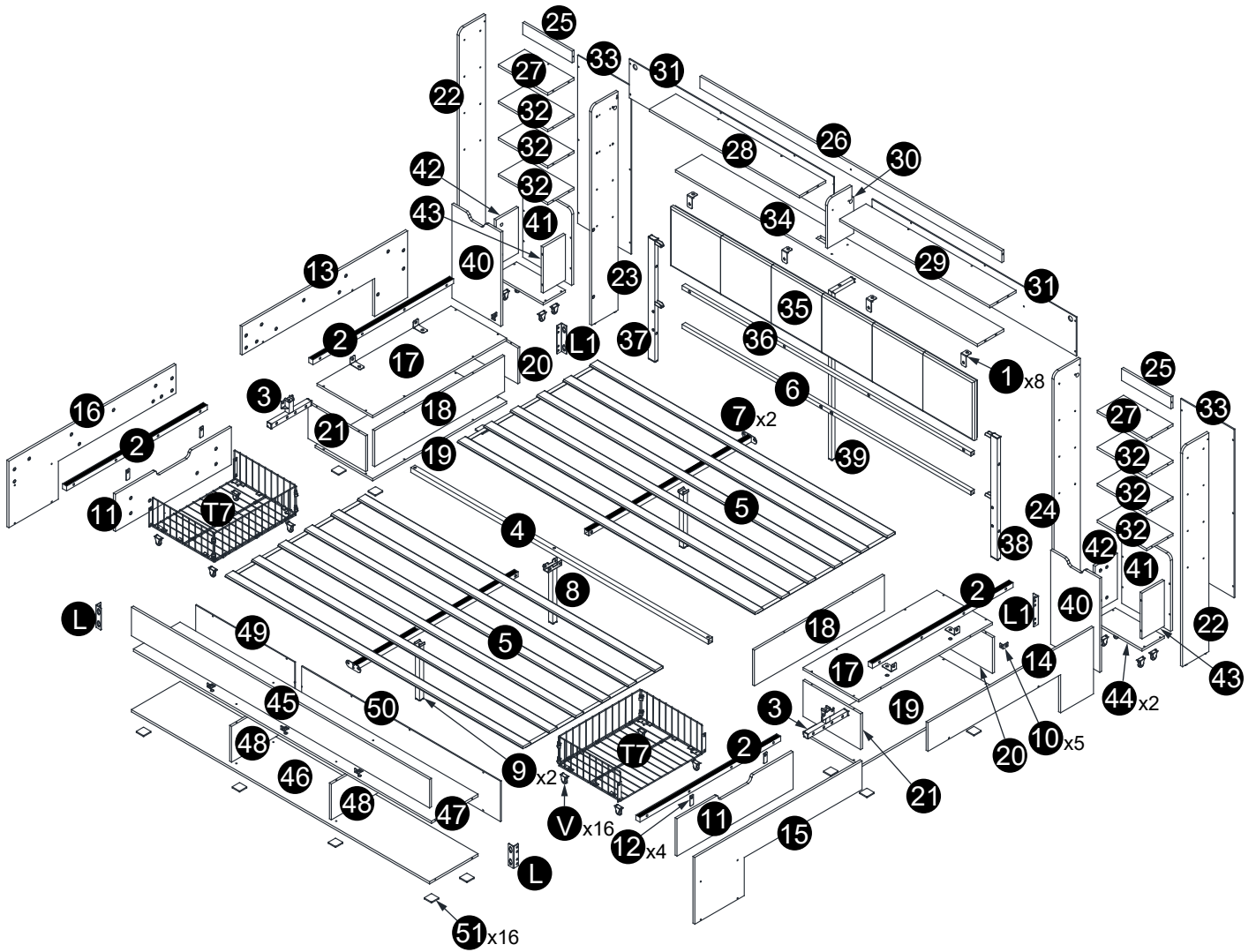

Part List N616P430131

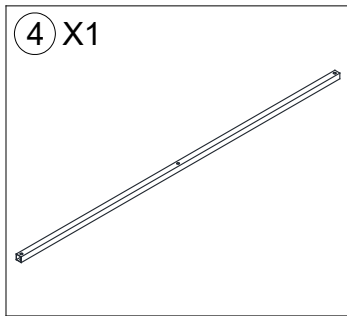
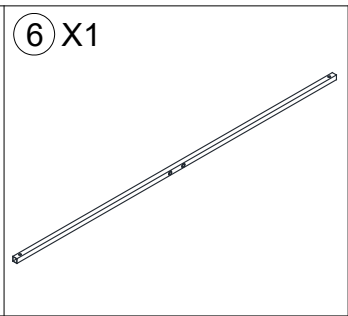
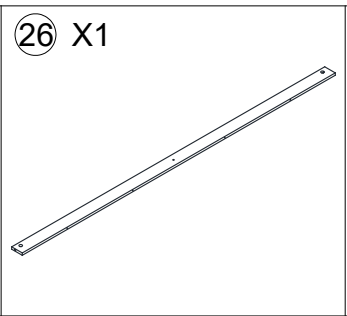
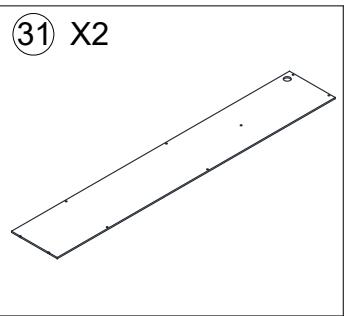
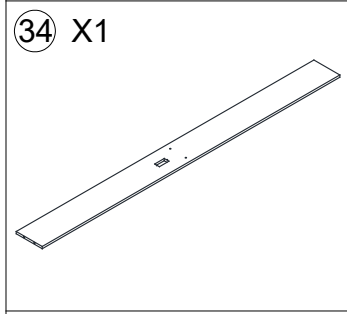
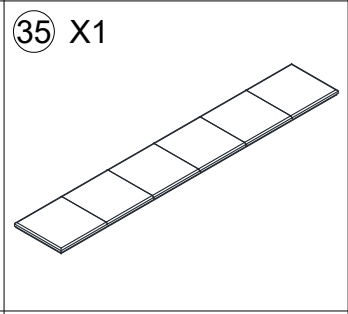
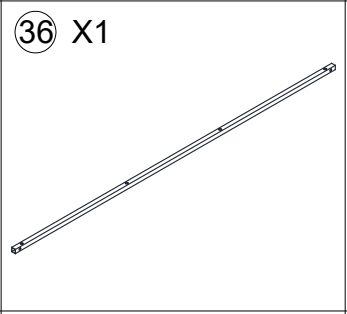
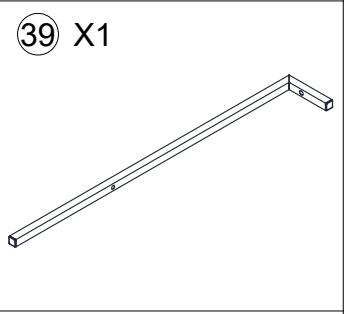
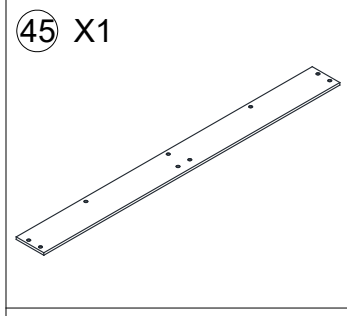
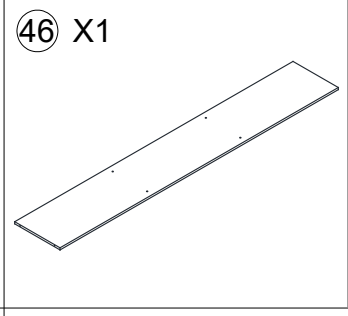
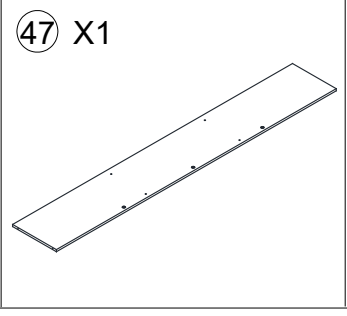
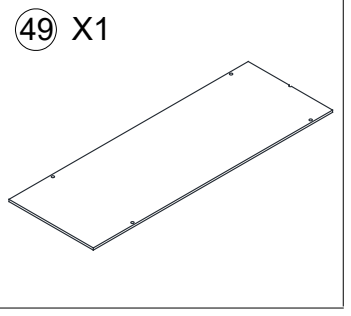
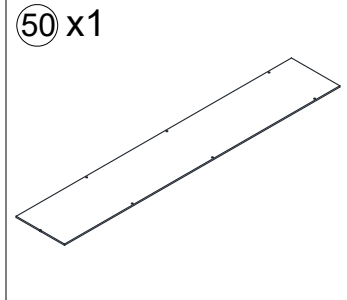
<p>④ X1</p> 	<p>⑥ X1</p> 	<p>②⑥ X1</p> 	<p>③① X2</p> 
<p>③④ X1</p> 	<p>③⑤ X1</p> 	<p>③⑥ X1</p> 	<p>③⑨ X1</p> 
<p>④⑤ X1</p> 	<p>④⑥ X1</p> 	<p>④⑦ X1</p> 	<p>④⑨ X1</p> 
<p>⑤① x1</p> 			

Part List N616P430132

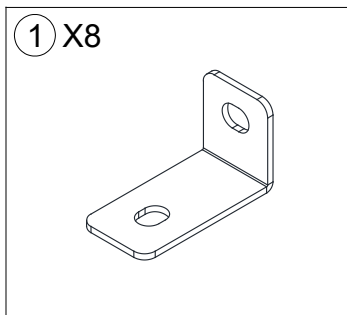
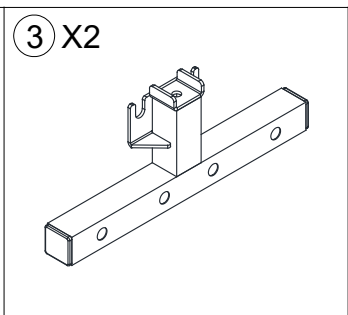
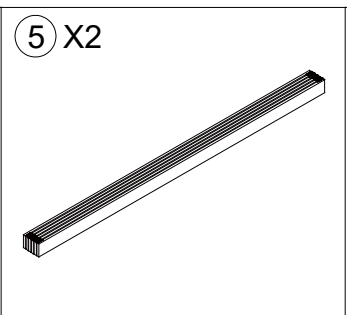
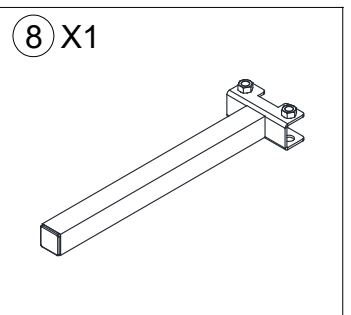
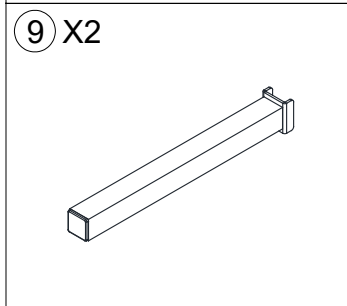
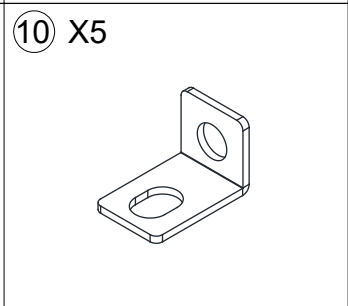
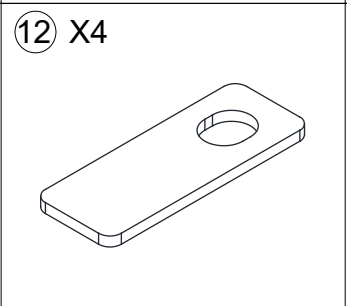
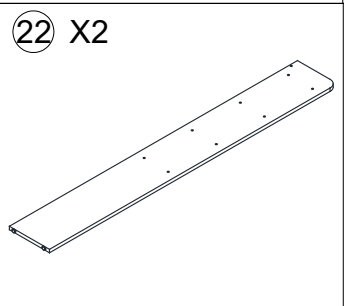
<p>① X8</p> 	<p>③ X2</p> 	<p>⑤ X2</p> 	<p>⑧ X1</p> 
<p>⑨ X2</p> 	<p>⑩ X5</p> 	<p>⑫ X4</p> 	<p>⑫② X2</p> 

<p>②③ X1</p>	<p>②④ X1</p>	<p>②⑦ X2</p>	<p>④① X2</p>
<p>④① X2</p>	<p>④④ X1</p>	<p>⑤① X16</p>	<p>Ⓛ X2</p>
<p>Ⓛ① X2</p>	<p>Ⓥ X16</p>		







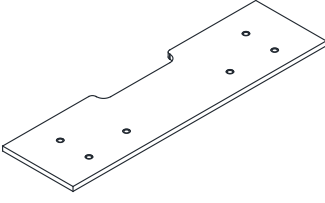
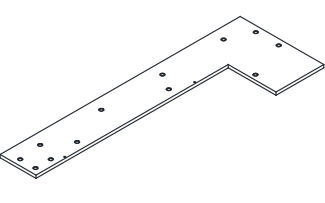
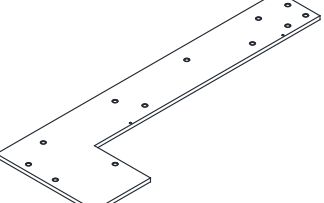
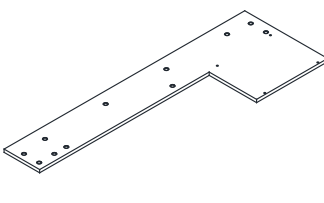
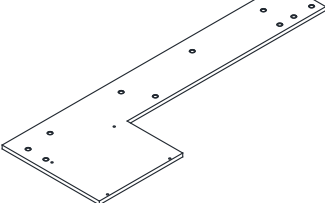
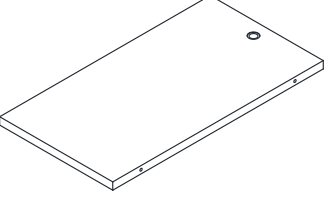
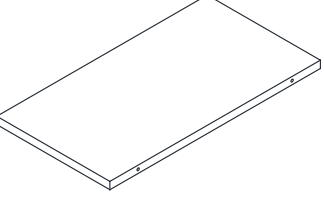
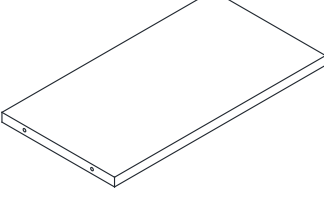
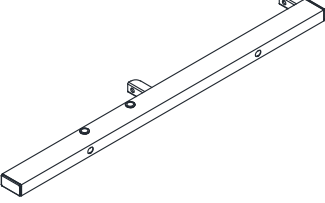
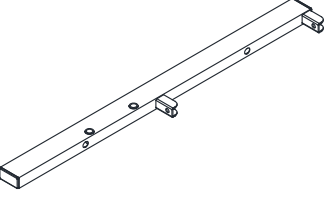
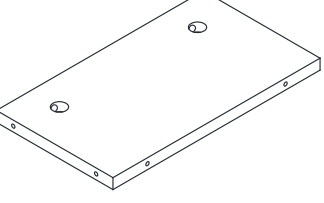
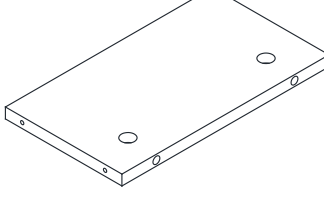
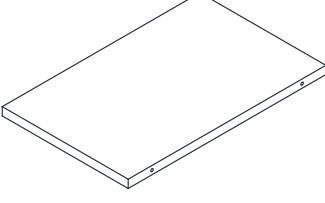
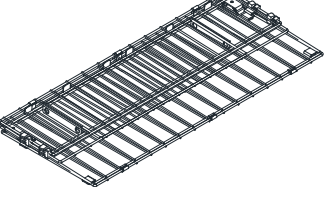
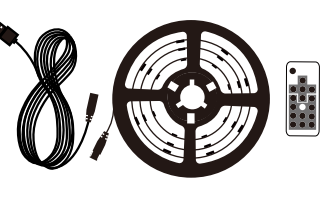
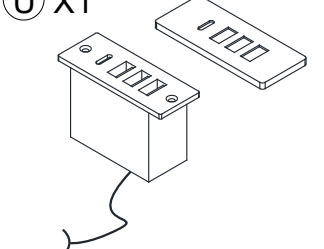



Part List N616P430133

<p>② X4</p>	<p>①⑦ X2</p>	<p>①⑧ X2</p>	<p>①⑨ X2</p>
<p>②⑤ X2</p>	<p>②⑧ X1</p>	<p>②⑨ X1</p>	<p>③① X1</p>
<p>③② X2</p>	<p>③③ X2</p>	<p>④④ X1</p>	

Part List N616P430134

<p>⑦ X2</p> 	<p>⑪ X2</p> 	<p>⑬ X1</p> 	<p>⑭ X1</p> 
<p>⑮ X1</p> 	<p>⑯ X1</p> 	<p>⑳ X2</p> 	<p>㉑ X2</p> 
<p>㉓ X4</p> 	<p>㉗ X1</p> 	<p>㉘ X1</p> 	<p>㉚ X2</p> 
<p>④③ X2</p> 	<p>④⑧ X2</p> 	<p>㉟⑦ X2</p> 	<p>Ⓚ X1</p> 
<p>Ⓚ X1</p> 			

Hardware List N616P430133

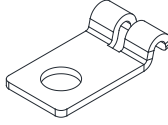
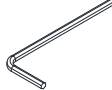
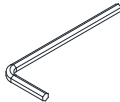
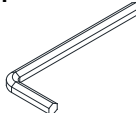
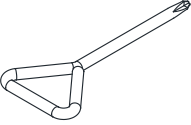
<p>A x62</p>  <p>M8X12</p>	<p>B x4</p>  <p>M8X14</p>	<p>C x1</p>  <p>M8X30</p>	<p>D x37</p>  <p>M8X33</p>	<p>E x7</p>  <p>M8X50</p>
<p>F x39</p>  <p>M5X30</p>	<p>G x105</p>  <p>M5X40</p>	<p>H x18</p>  <p>ST3.5X12</p>	<p>I x22</p>  <p>φ15X10</p>	<p>J x22</p>  <p>φ7X40</p>
<p>M x8</p>  <p>M4X10</p>	<p>N x4</p> 	<p>O x1</p>  <p>M4</p>	<p>P x1</p>  <p>M5</p>	<p>Q x1</p>  <p>M8</p>
<p>R x1</p> 				

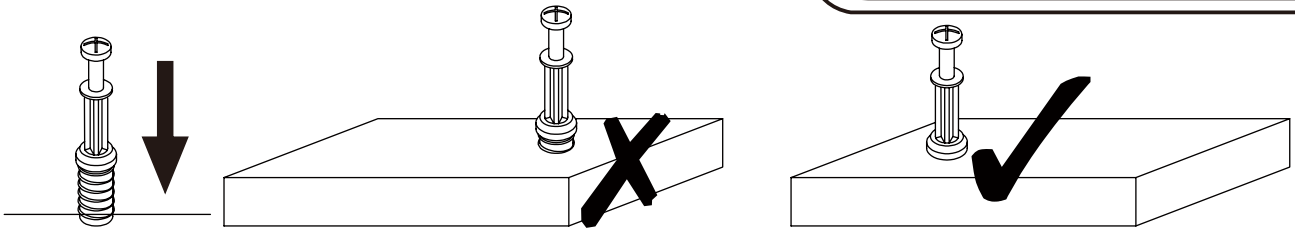

EN_QUICKFIT: Tighten quickfit until shoulder is flush with panel. Do not overtighten or undertighten.

FR_RACCORD RAPIDE: Faites serrer le raccord rapide jusqu'à ce que l'épaulement soit parfaitement encastré dans le panneau. Il ne faut ni trop serrer ni insuffisamment serrer.

ES_QUICKFIT: Apriete quickfit hasta que el hombro se descargue con el panel. NO lo sobreapriete ni lo apriete poco.

DE_QUICKFIT: Ziehen Sie den Quickfit fest, bis die Schulter mit der Platte bündig ist. Bitte nicht zu fest oder zu schwach anziehen.

IT_MONTAGGIO RAPIDO: Stringere il montaggio rapido fino a quando la spalla è a filo con il pannello, non stringere troppo o troppo poco.

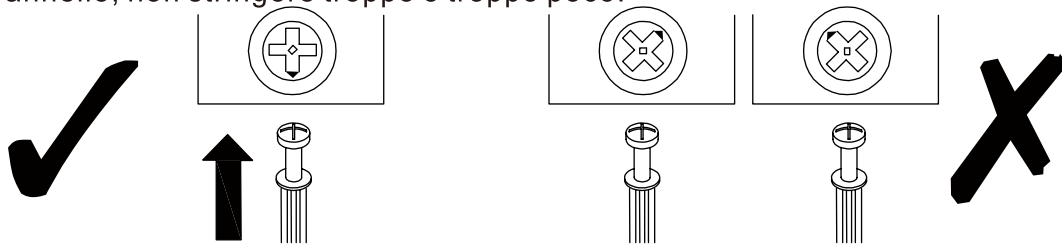

EN_CAM LOCK: When fitting cam lock, ensure starting position is correct before you insert connecting quickfit.

FR_SERRURE BATTEUSE: Avant d'insérer la serrure batteuse, veillez à la bonne orientation avant d'insérer le raccord rapide.

ES_CIERRE DE LA CÁMARA: Cuando instale el cierre de la cámara, asegúrese de que la posición de inicio es correcta antes de que inserte el quickfit conector.

DE_CAM-LOCK: Achten Sie bei der Montage des Cam-Locks auf die richtige Ausgangsposition, bevor Sie den Quickfit einsetzen.

IT_BLOCCAGGIO A CAMMA: Quando si monta il bloccaggio a camma, assicurarsi che la posizione iniziale sia corretta prima di inserire il montaggio rapido di collegamento.

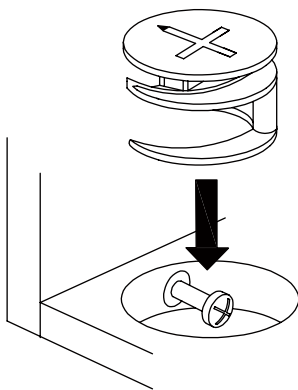

EN_Quickfit head should be in the centre of the cam lock when the two panels are joined.

Cam lock should be inserted before quickfit.

FR_Lorsque les deux panneaux sont assemblés, la tête du raccord rapide doit reposer au centre de la serrure batteuse. Il faut insérer la serrure batteuse avant le raccord rapide.

ES_El cabezal del quickfit debe estar en el centro del cierre de la cámara cuando se unan los dos paneles.

Se debe insertar el cierre de la cámara antes que el quickfit.

DE_Der Quickfit-Kopf sollte sich in der Mitte des Cam-Locks befinden, wenn die beiden Platten zusammengefügt sind. Der Cam-Lock sollte vor dem Quickfit eingesetzt werden.

IT_La testa del montaggio rapido deve trovarsi al centro del bloccaggio a camma quando i due pannelli sono uniti.

Il Bloccaggio a Camma deve essere inserito prima del montaggio rapido.

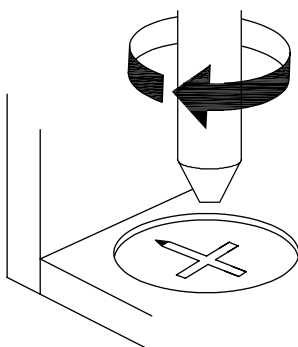

EN_Turn cam lock clockwise to tighten.

FR_Faites tourner la serrure batteuse dans le sens des aiguilles d'une montre pour la resserrer.

ES_Gire el cierre de la cámara en sentido horario para apretarlo.

DE_Drehen Sie den Cam-Lock im Uhrzeigersinn, um ihn festzuziehen.

IT_Ruotare il bloccaggio a camma in senso orario per stringere.

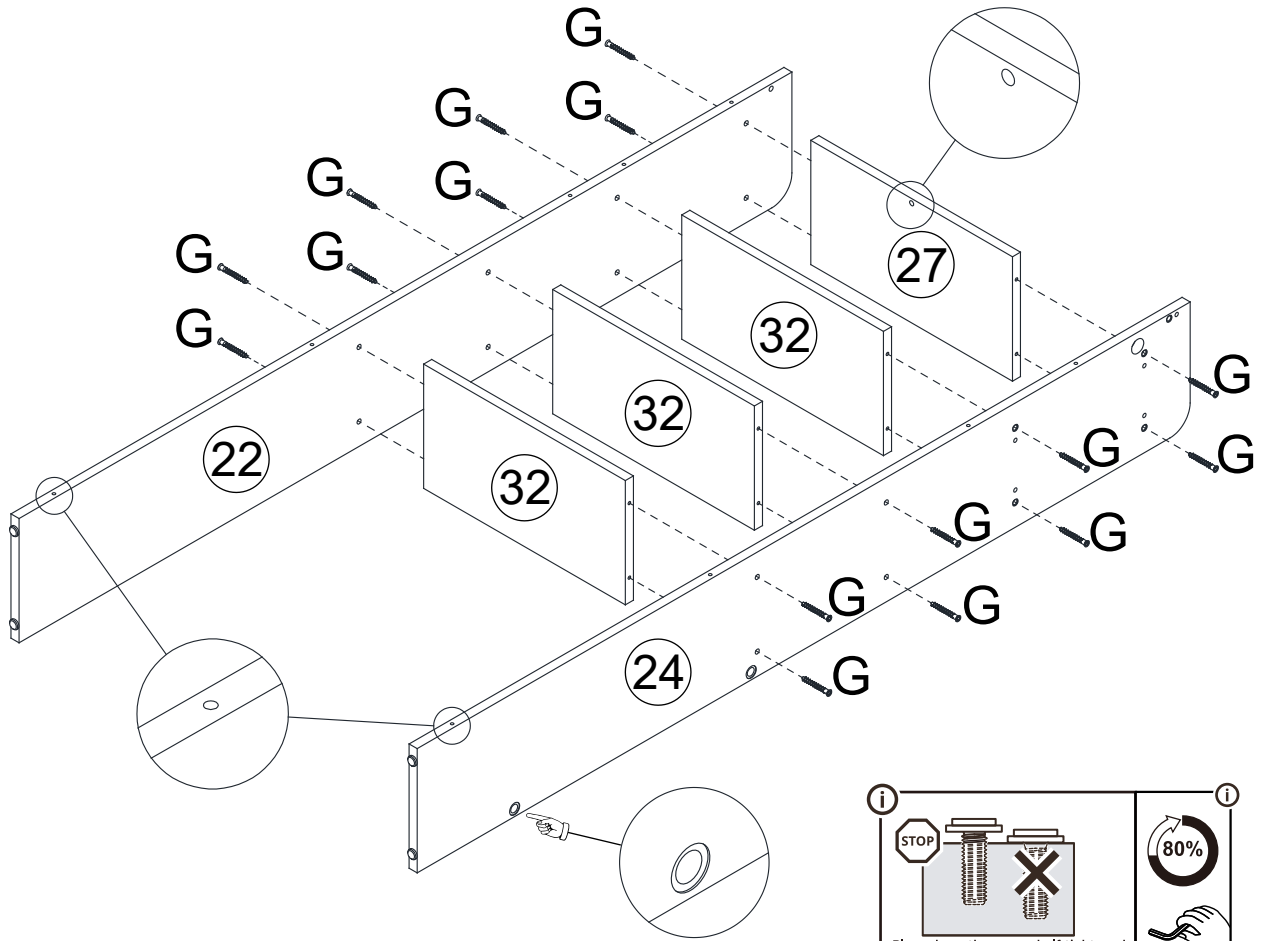

i **STOP** **X** **80%** **i**

Please keep the screws half-tightened during installation.

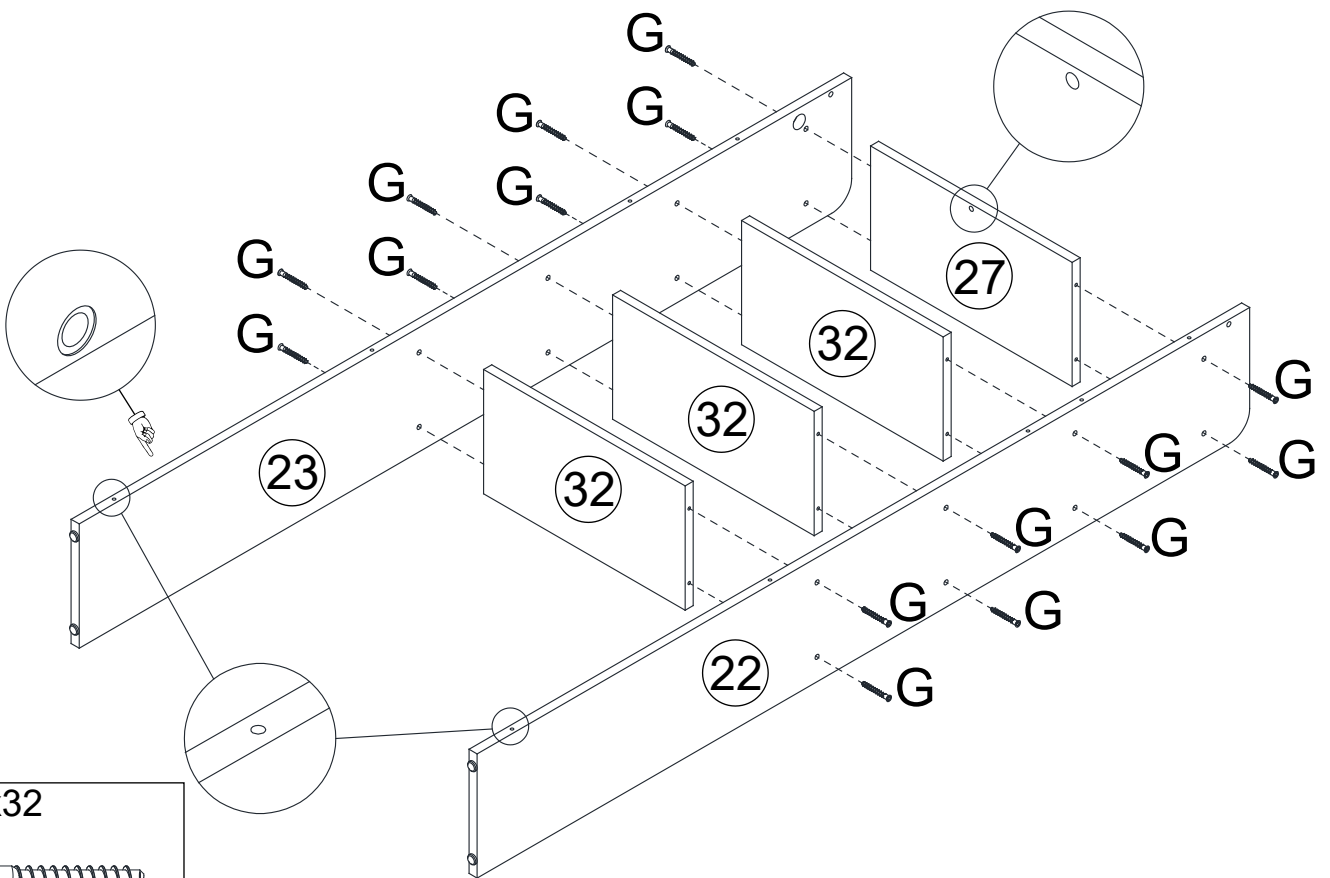

Gx32



M5X40

2

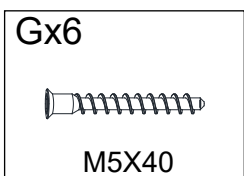
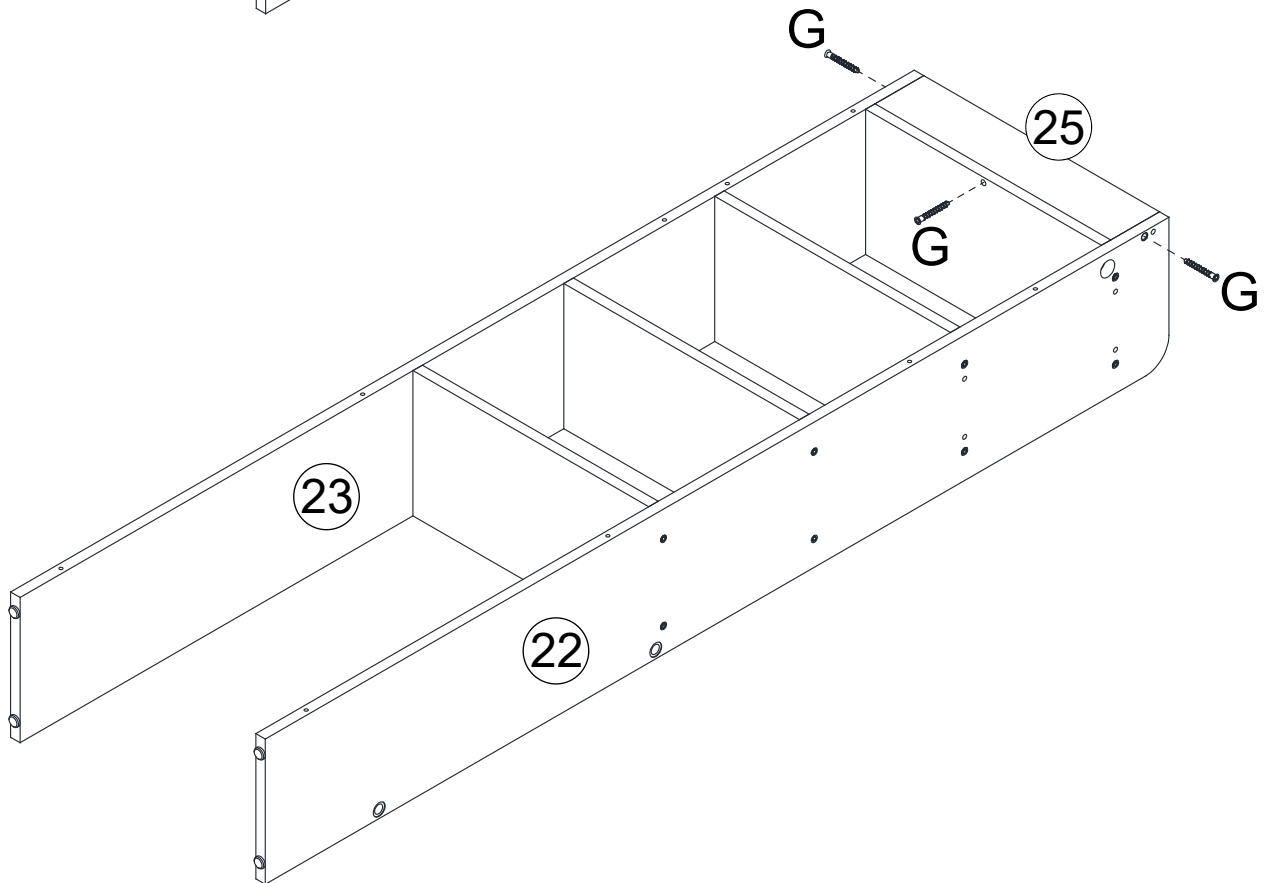
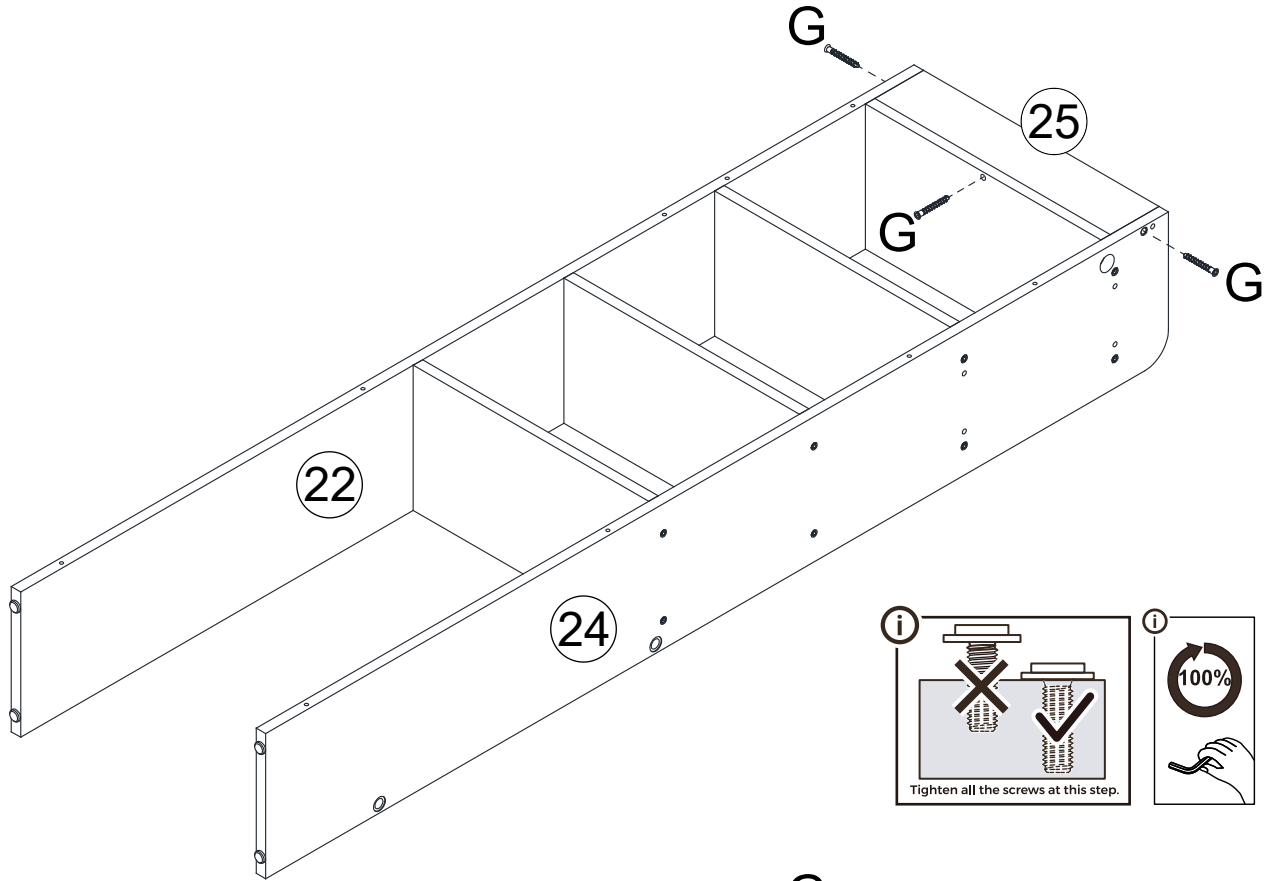

3

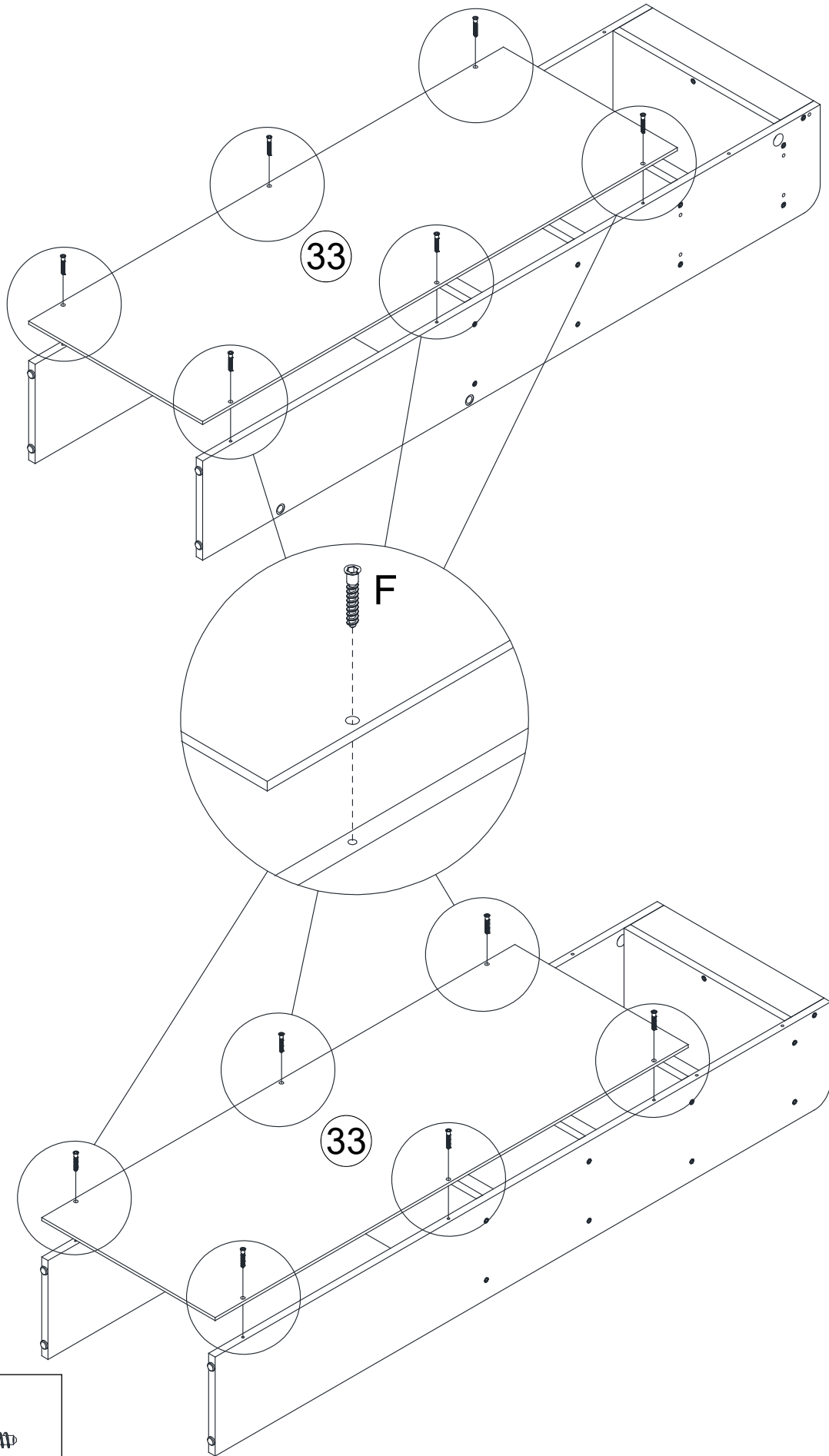

Fx12



M5X30

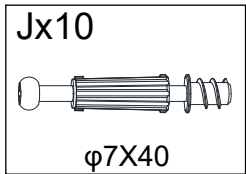
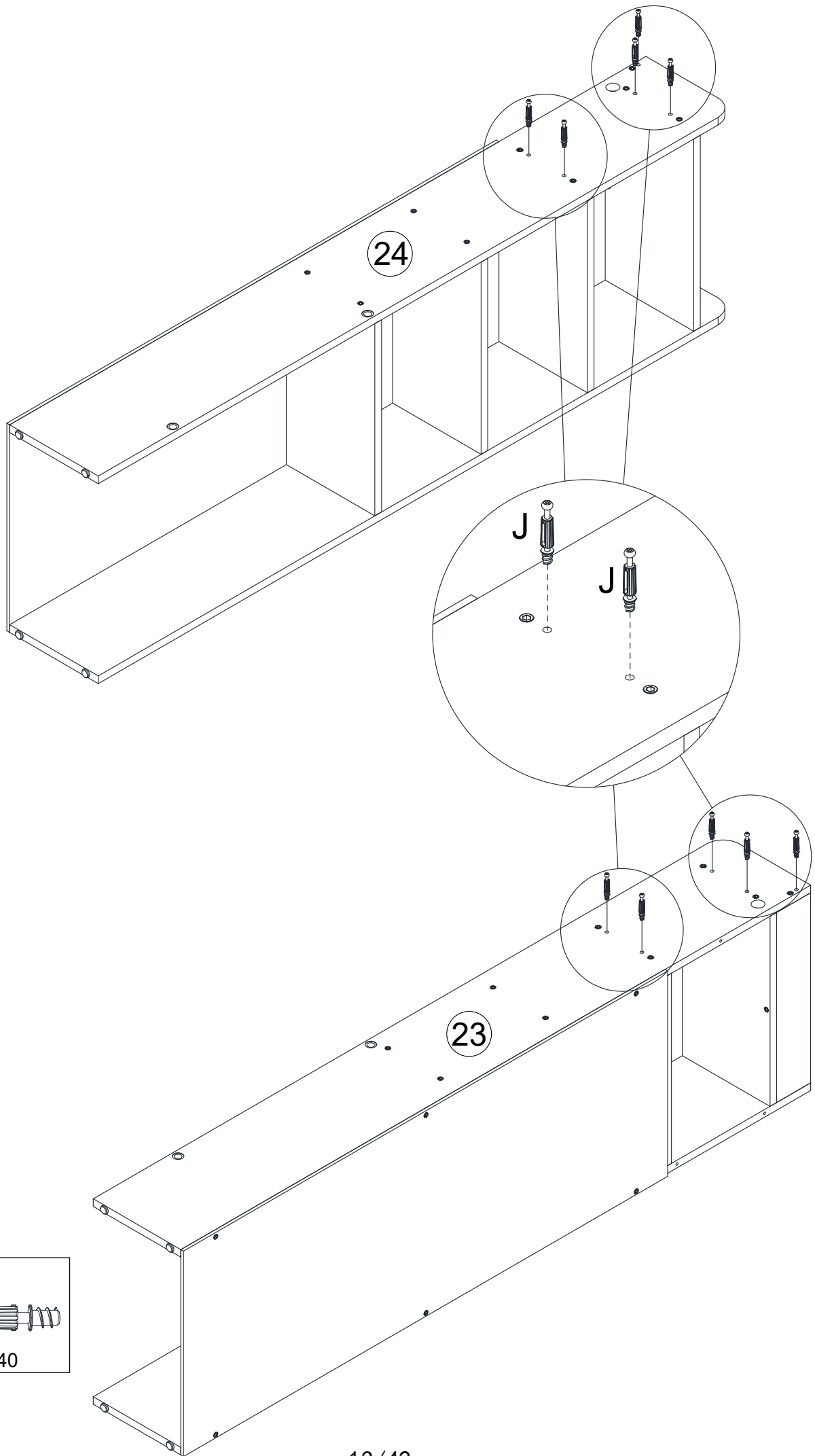

5

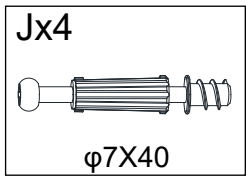
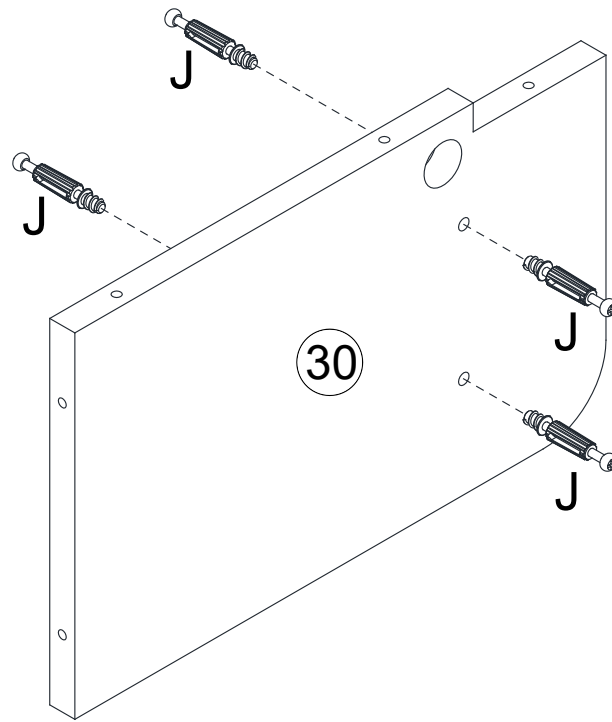

6

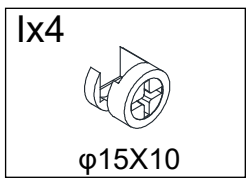
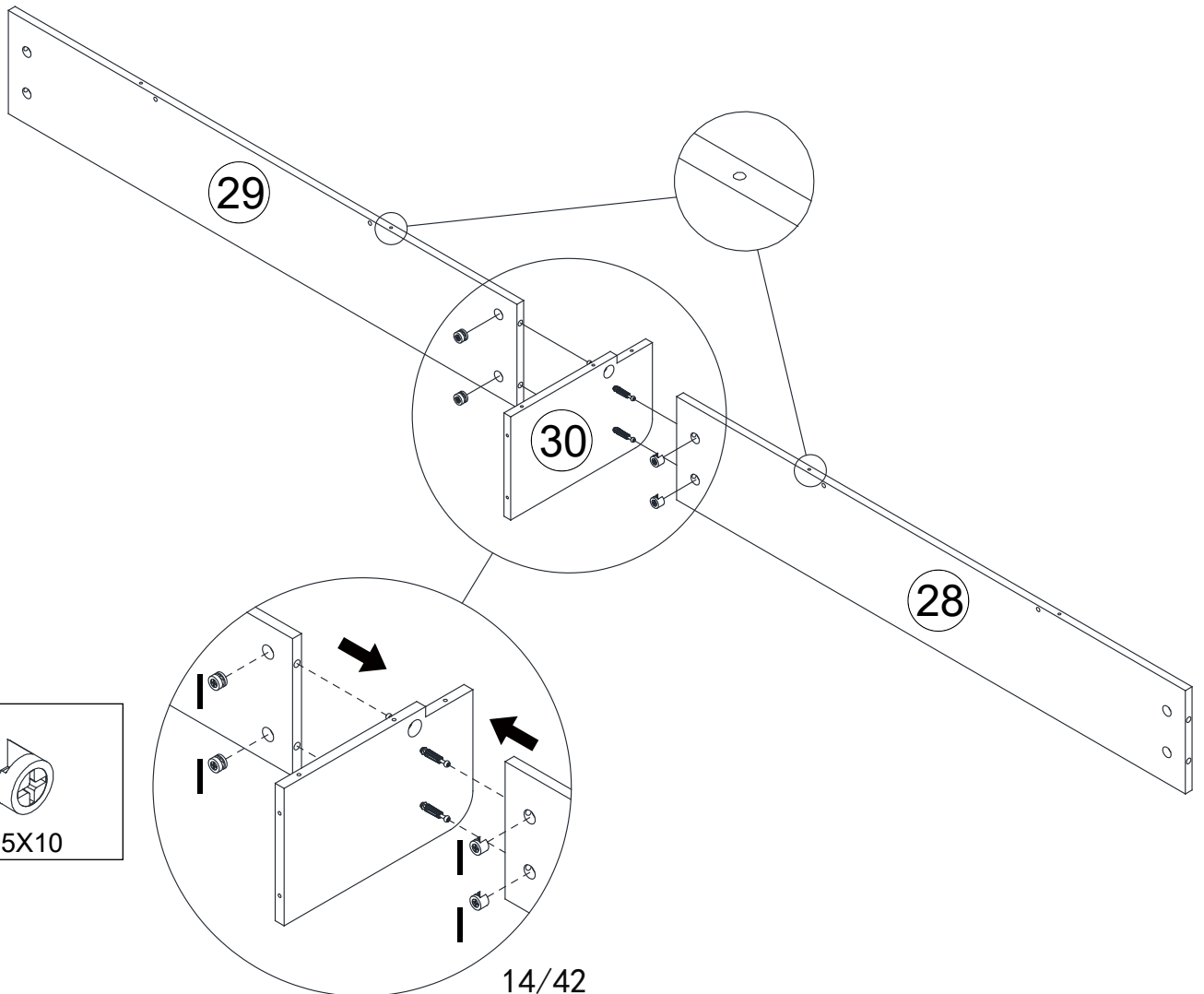

7

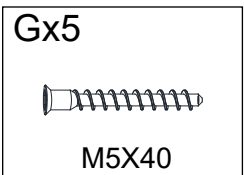
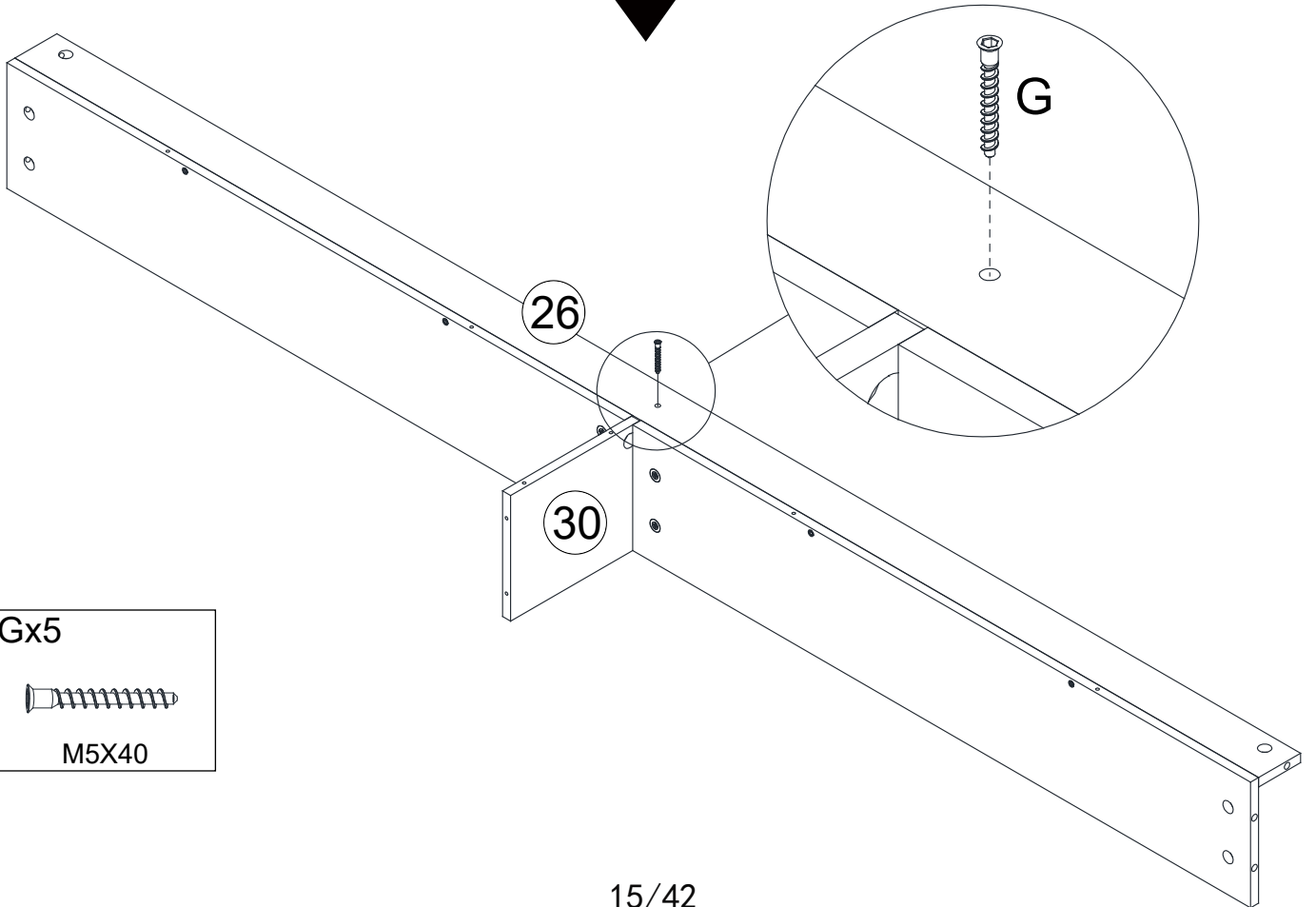
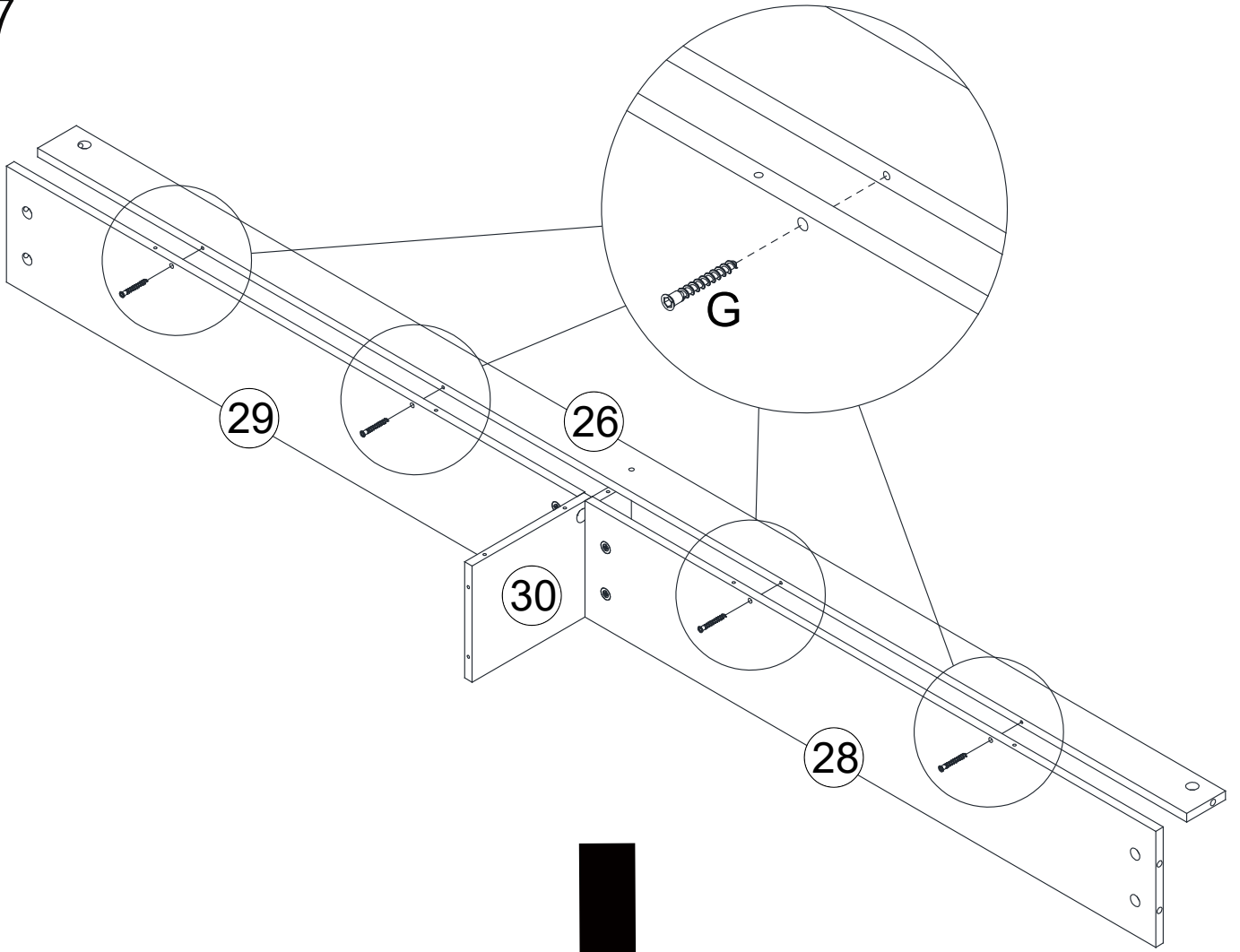

8

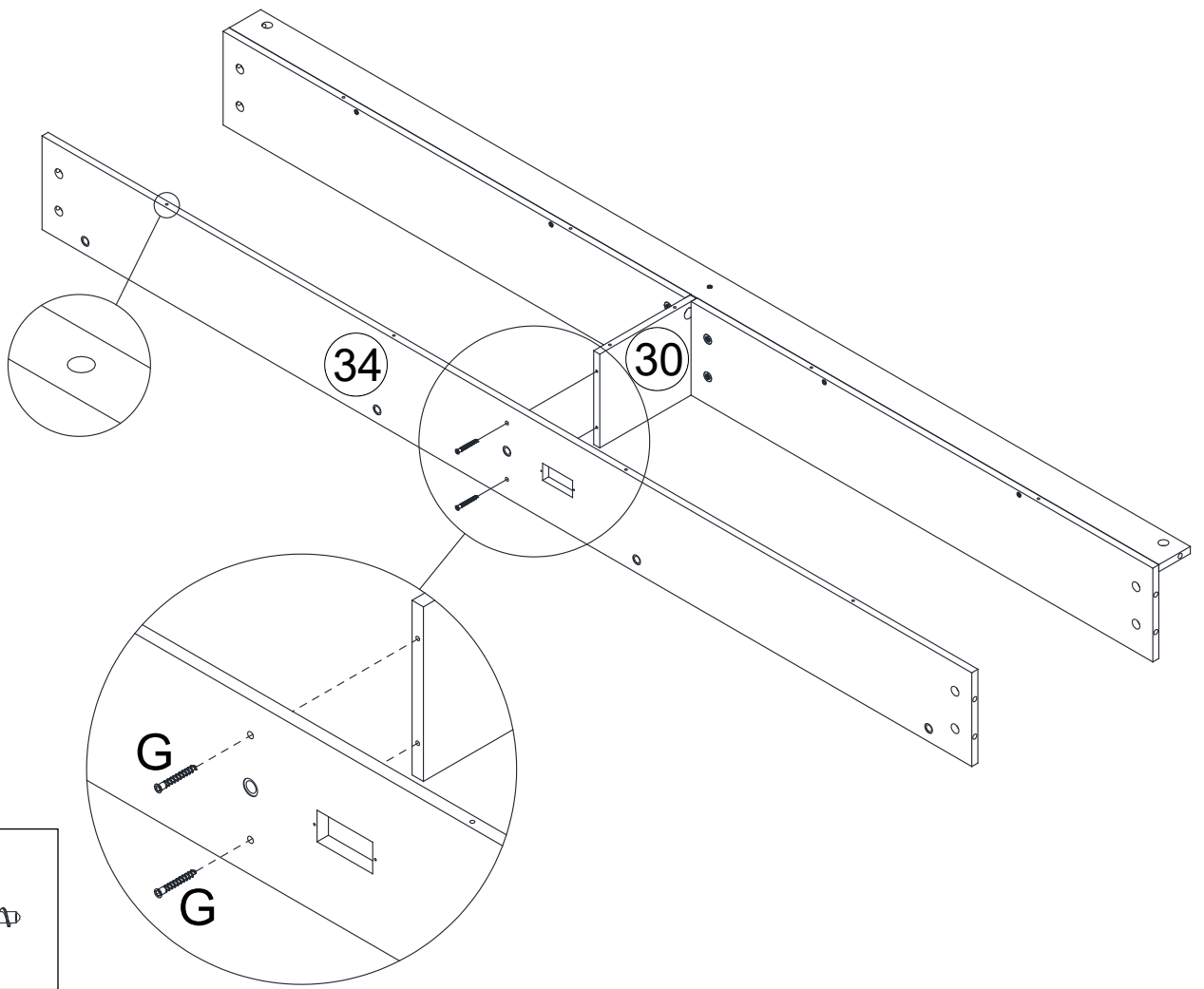

9

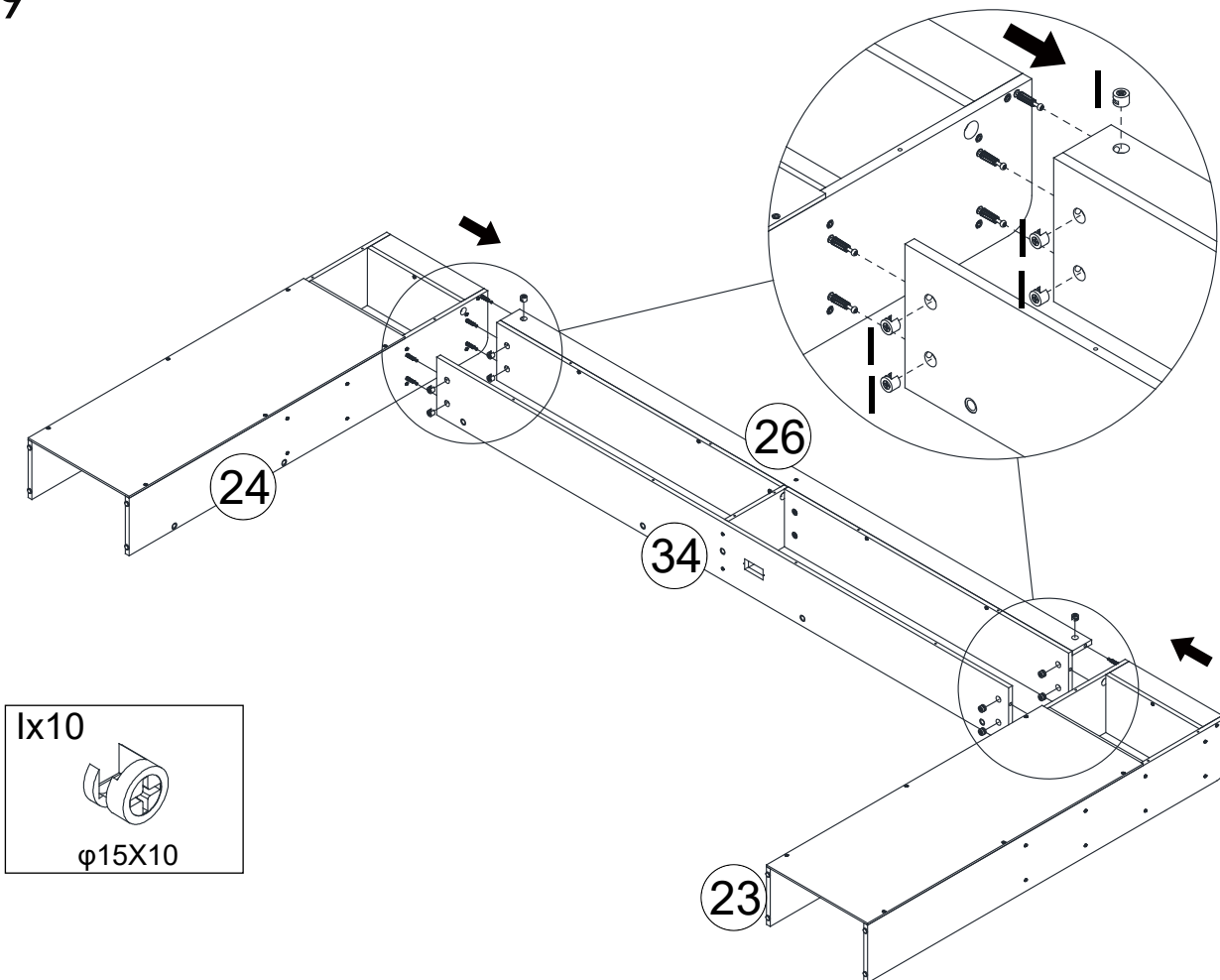

10

Tear the double-sided tape
Zerrei das band
Dchirer la bande double face
Strappamento del nastro adesivo
Rasgar cinta doble cara

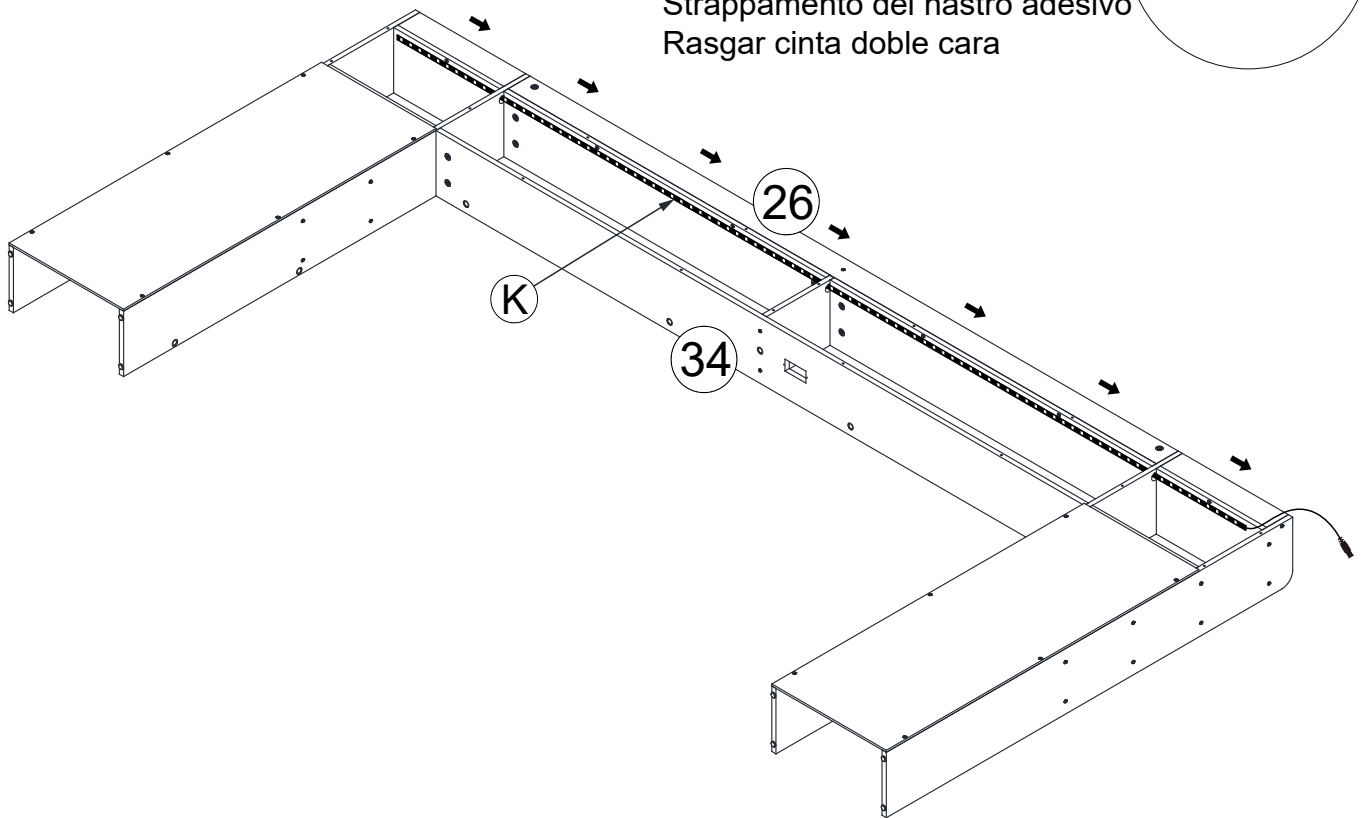
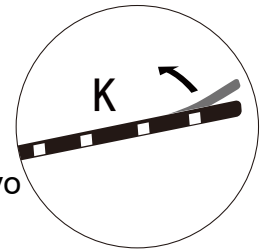

11

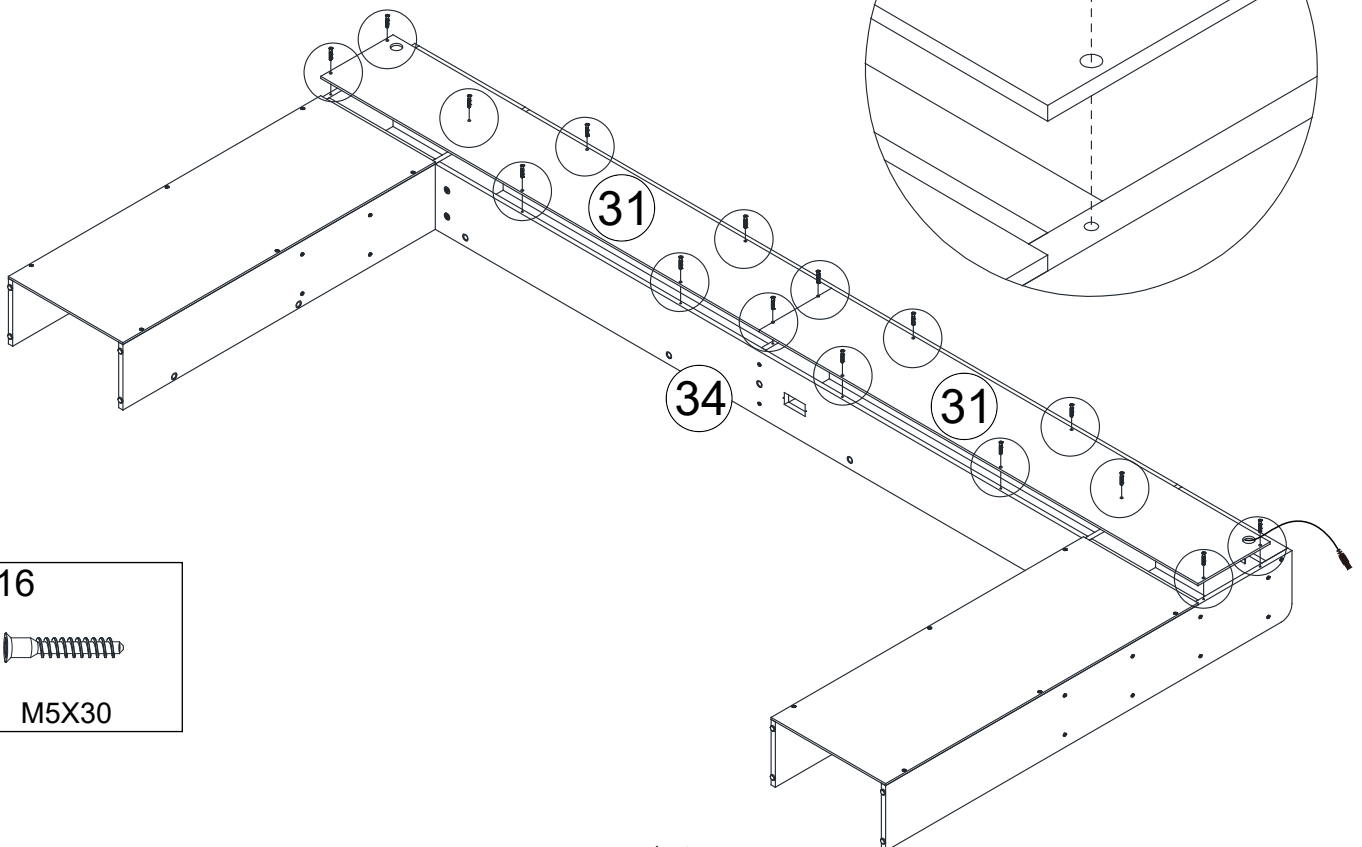
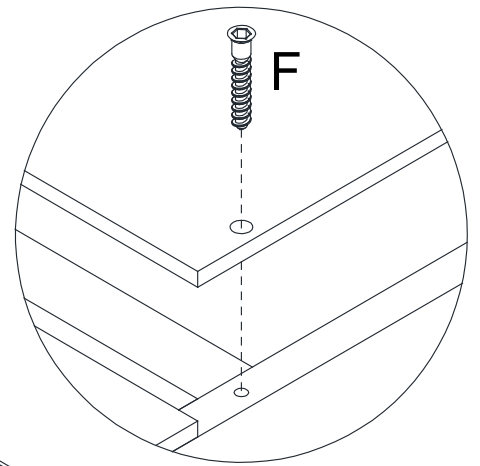

Fx16



M5X30

12

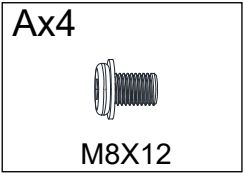
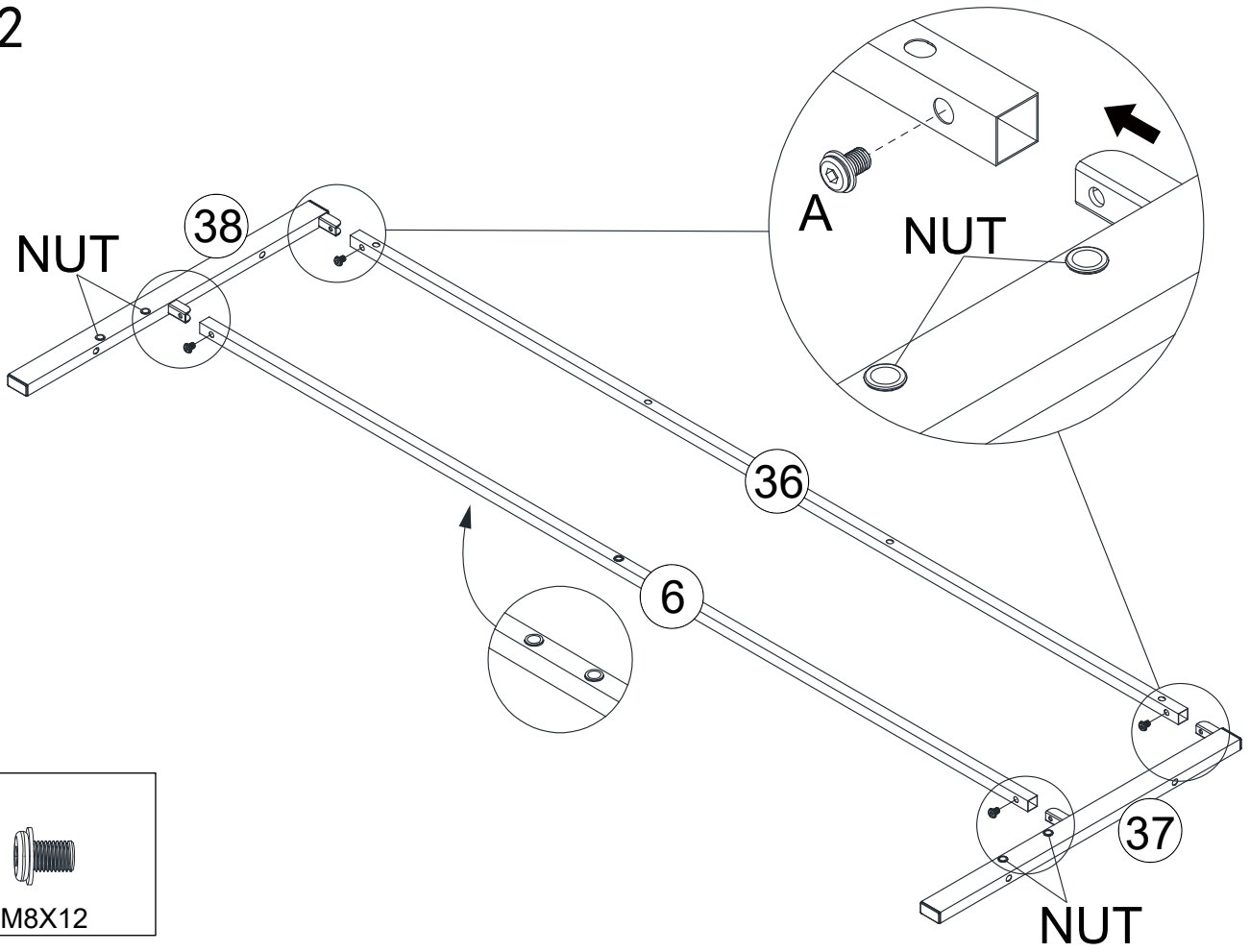

13

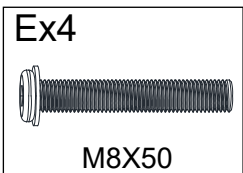
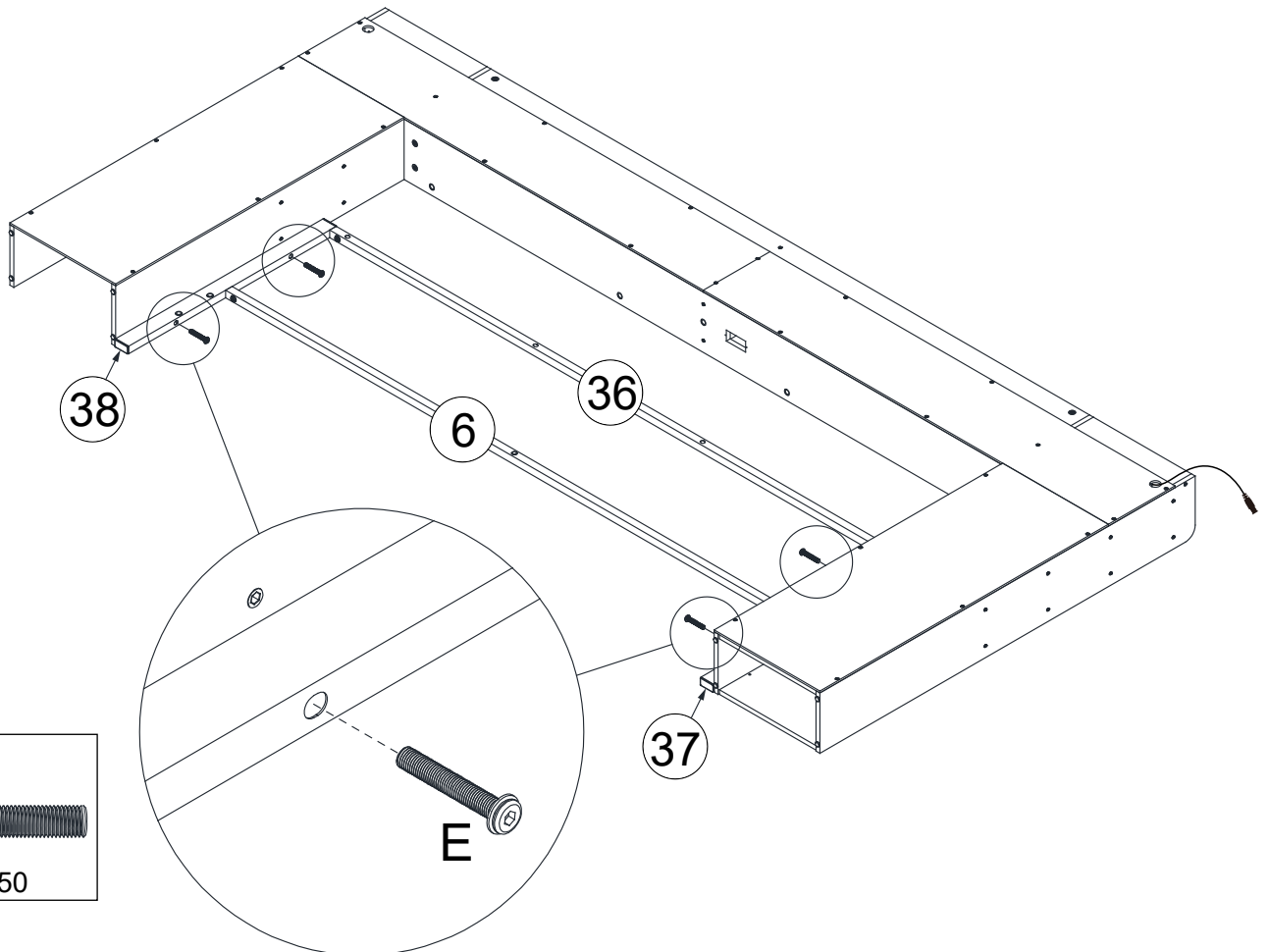

14

This screw is white zinc plated.
Ce boulon est zincé blanc.
Diese schraube ist zink.
Questa vite è di zinco bianco.
Este tornillo es zinc blanco.

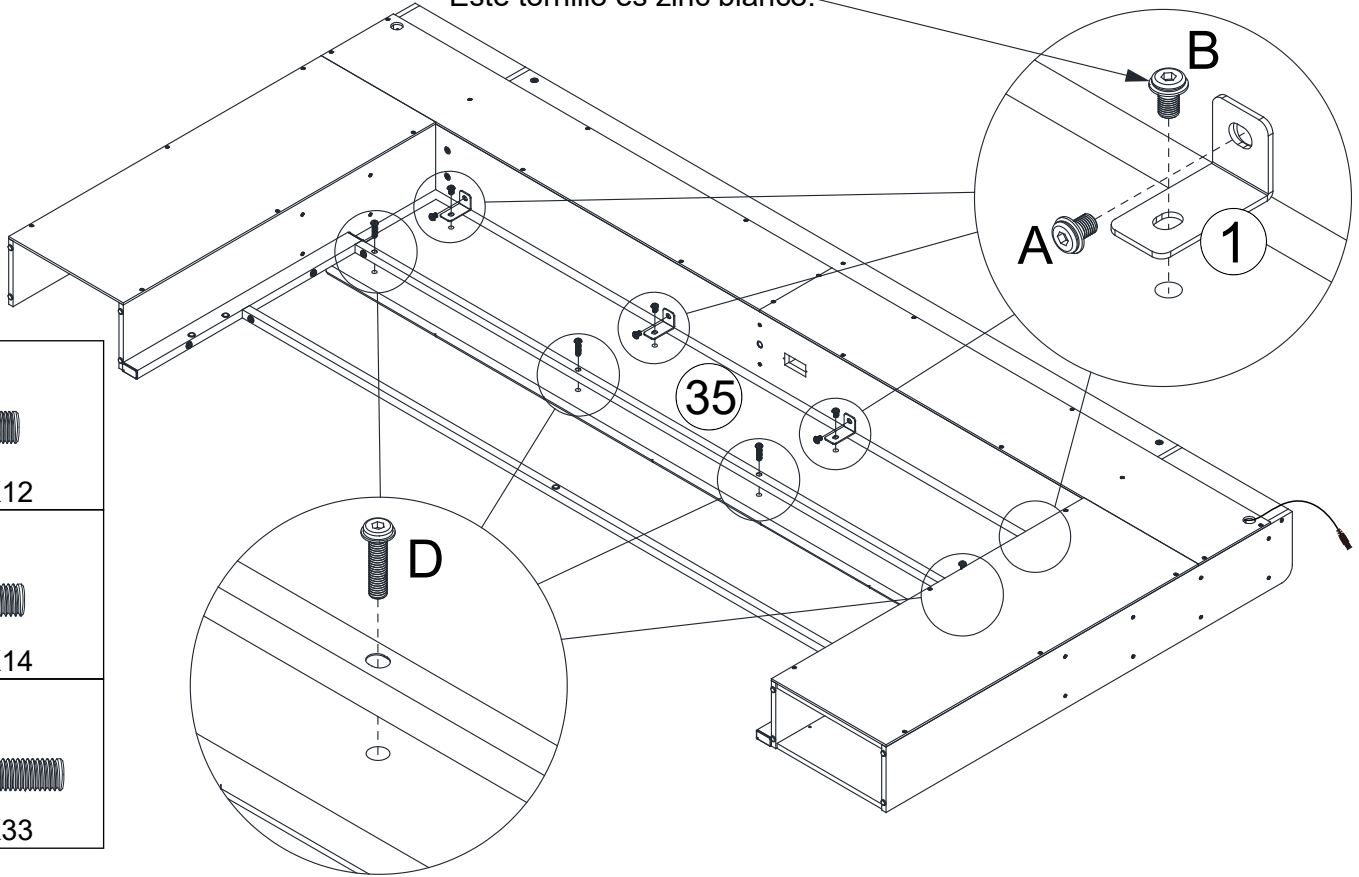
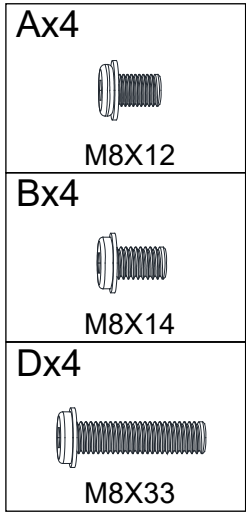
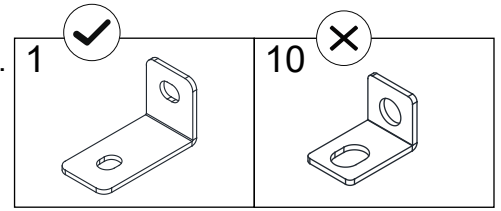

15



This screw is white zinc plated.
Ce boulon est zincé blanc.
Diese schraube ist zink.
Questa vite è di zinco bianco.
Este tornillo es zinc blanco.

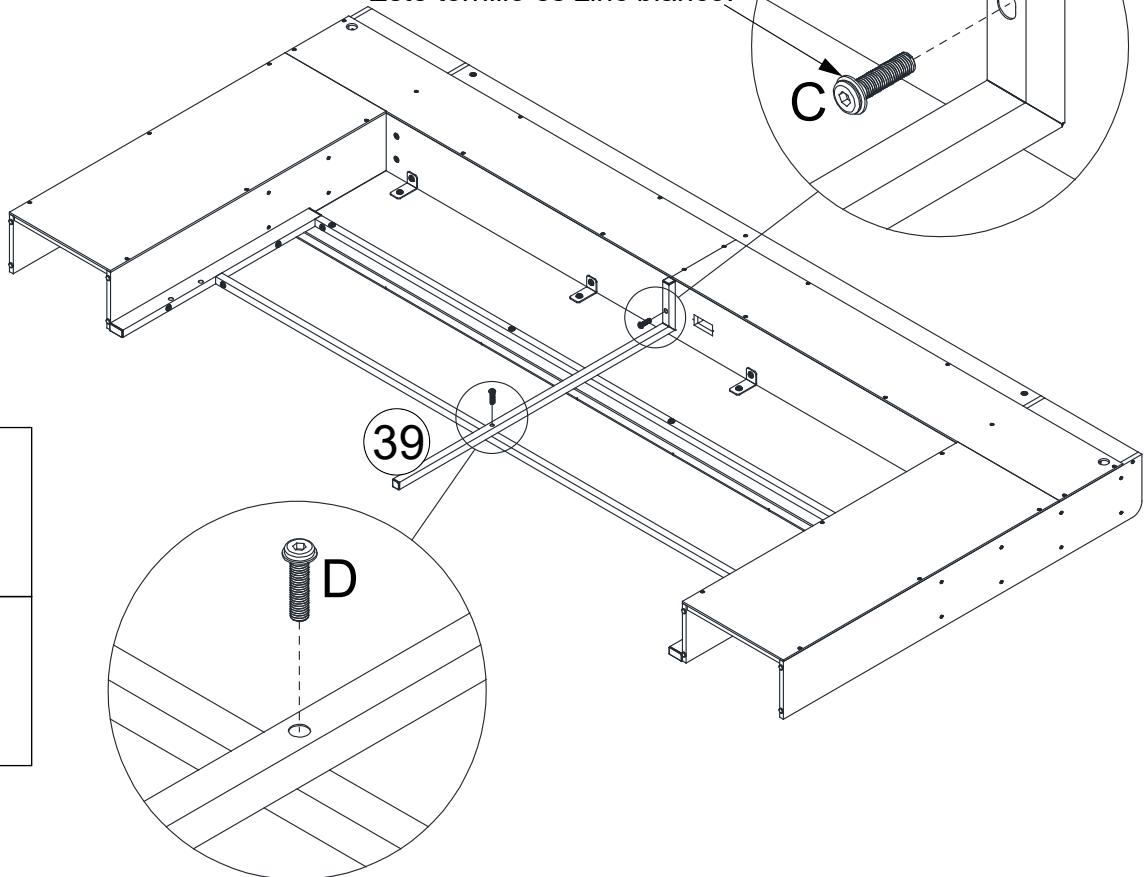
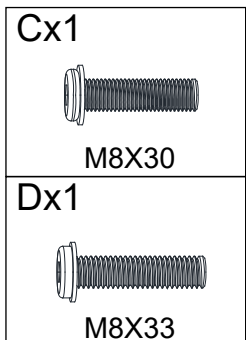
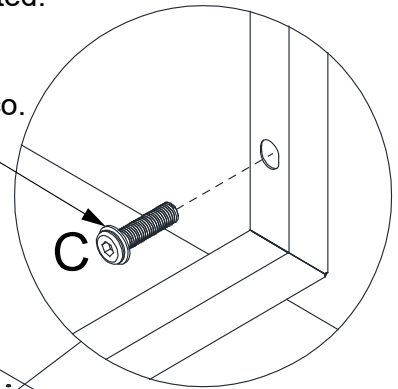

16

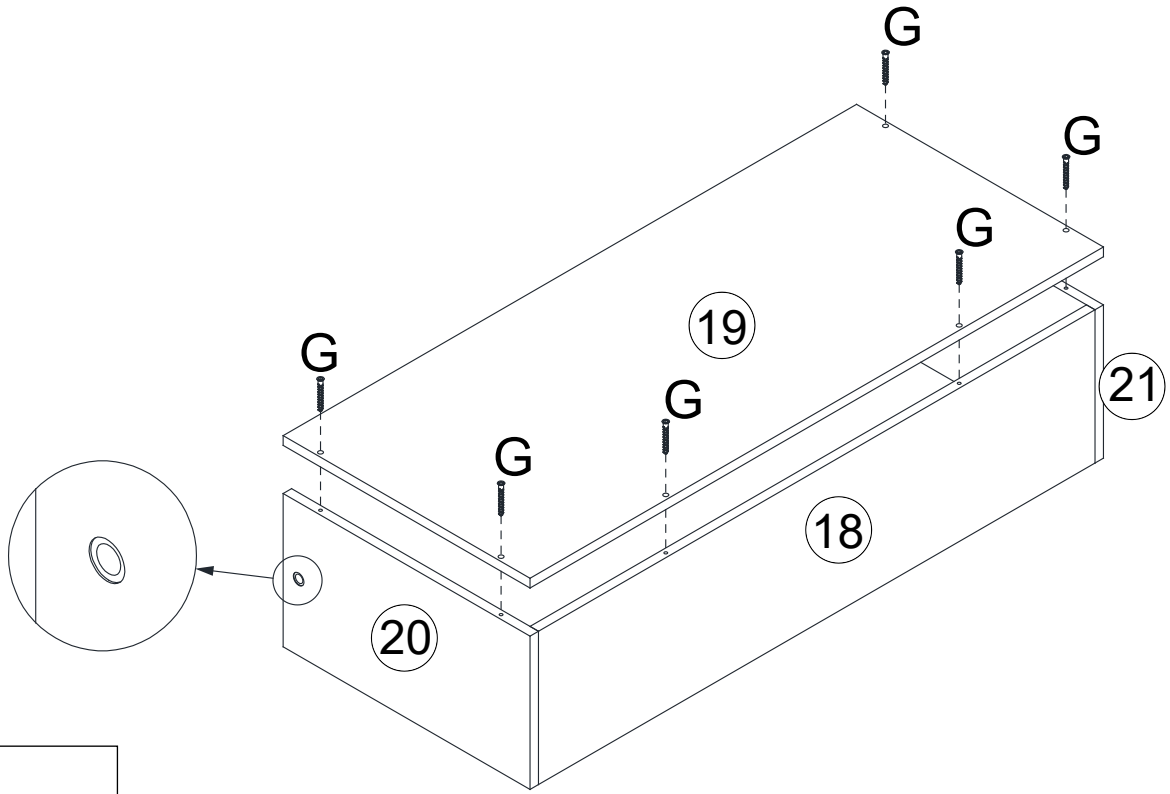

17

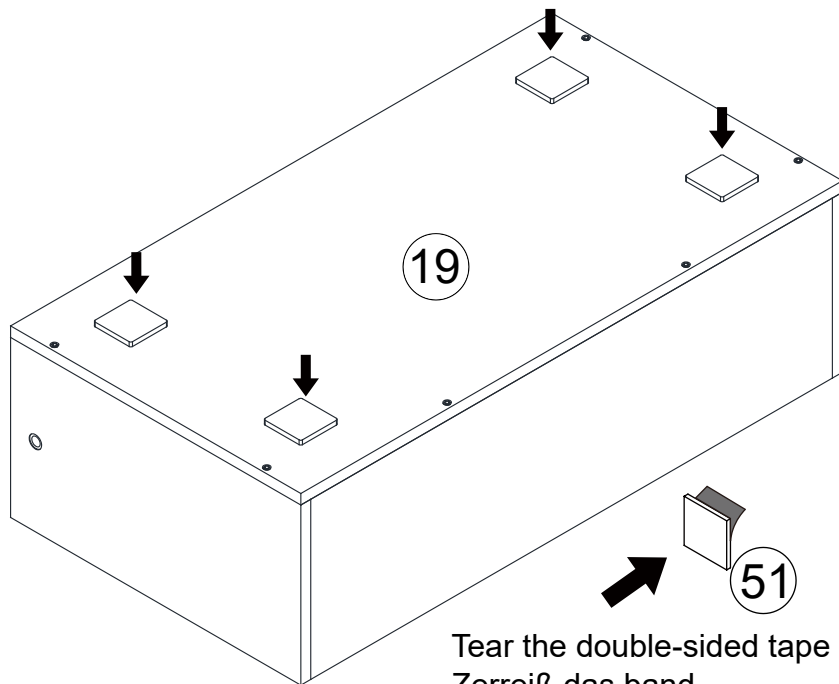

Tear the double-sided tape
Zerrei das band
Dchirer la bande double face
Strappamento del nastro adesivo
Rasgar cinta doble cara

18

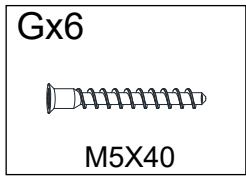
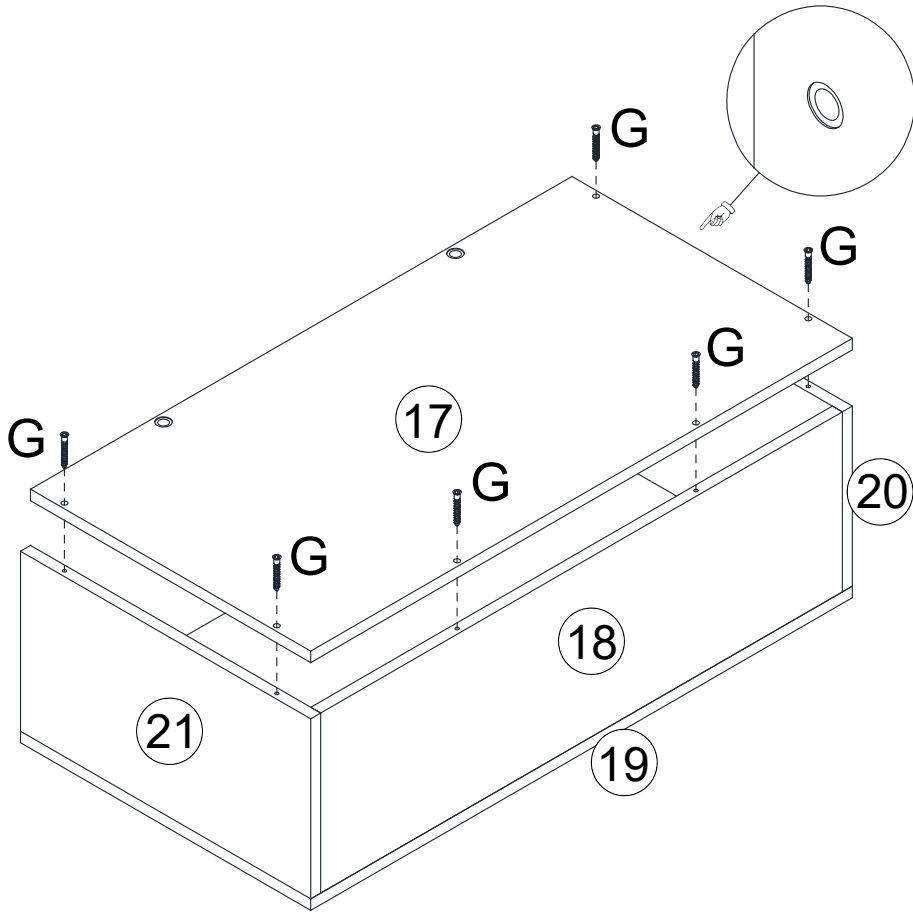

19

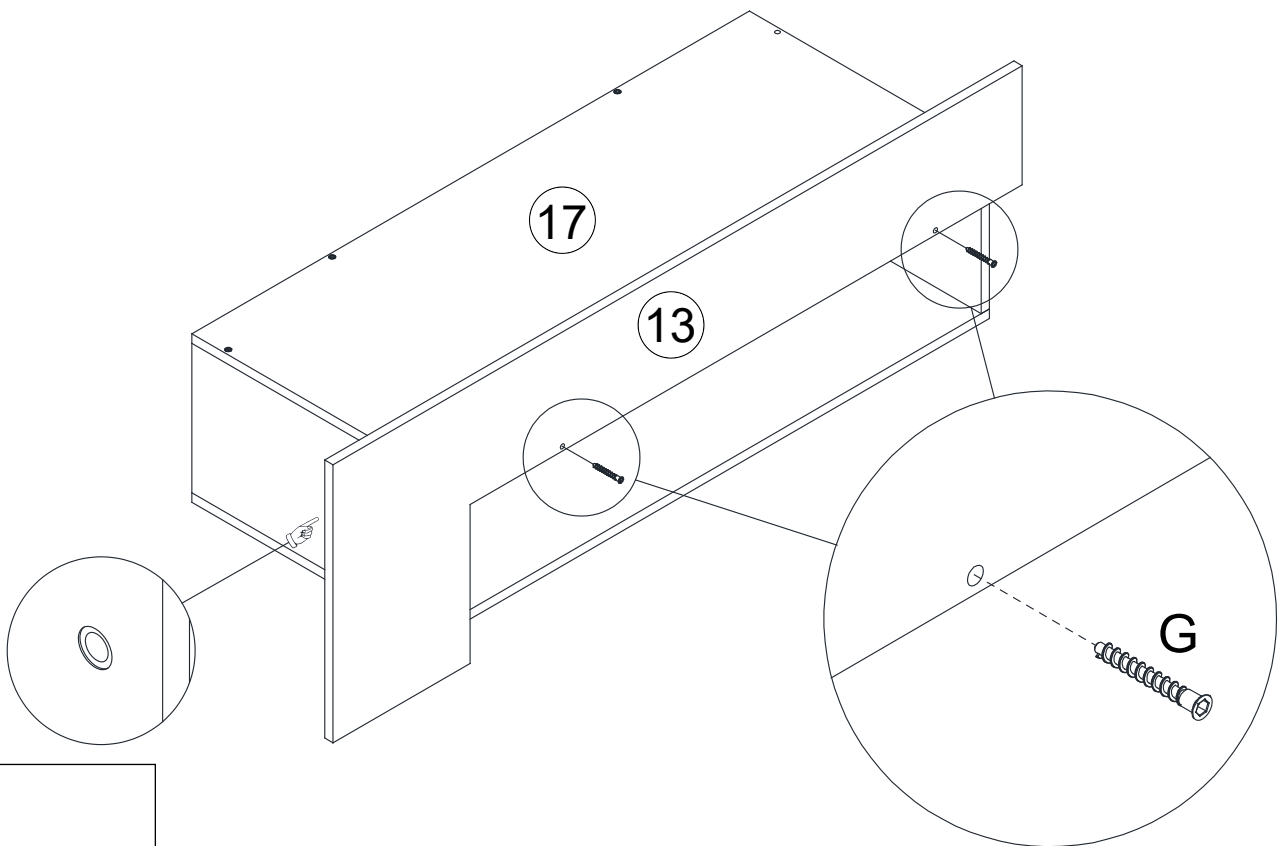

20

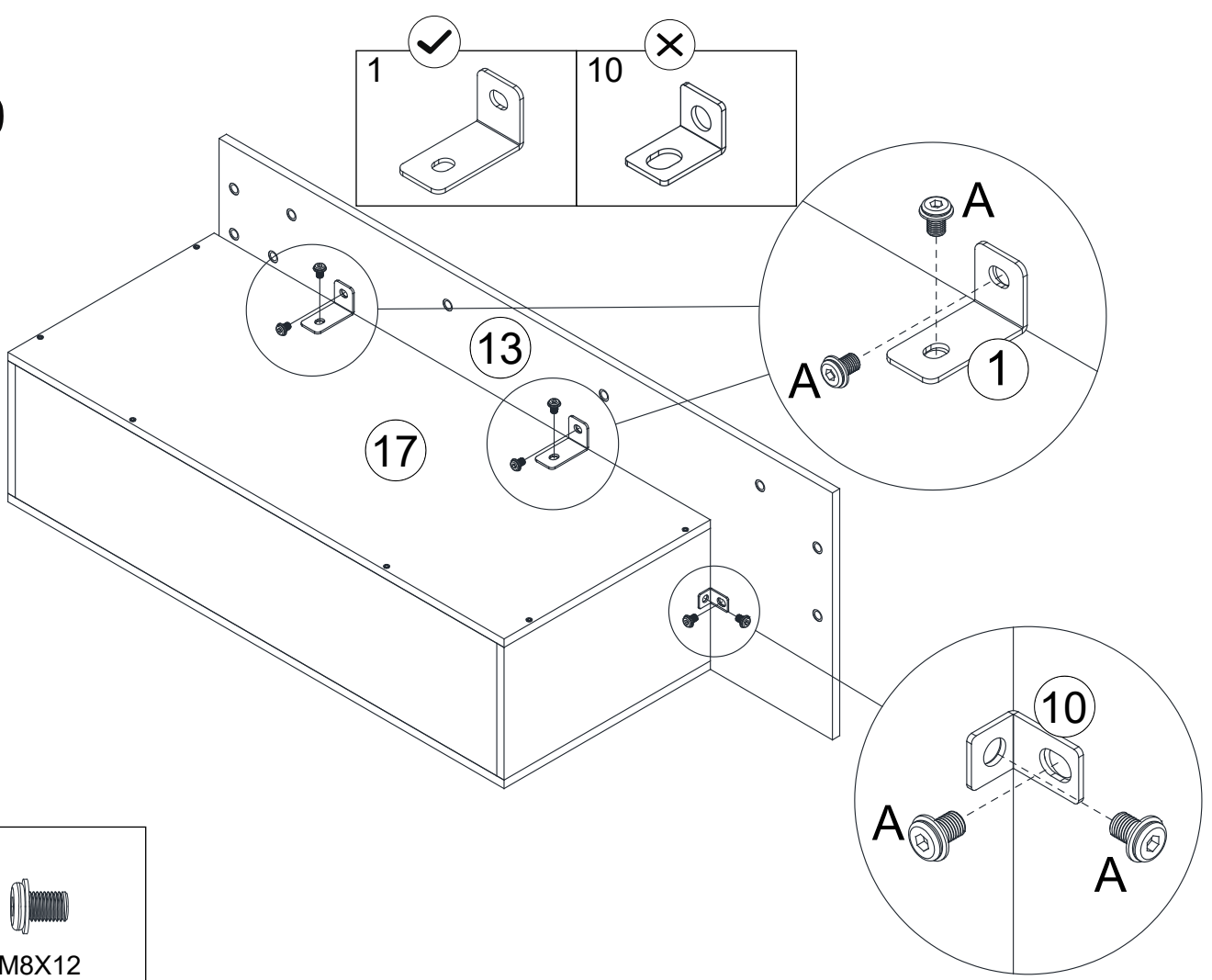

21

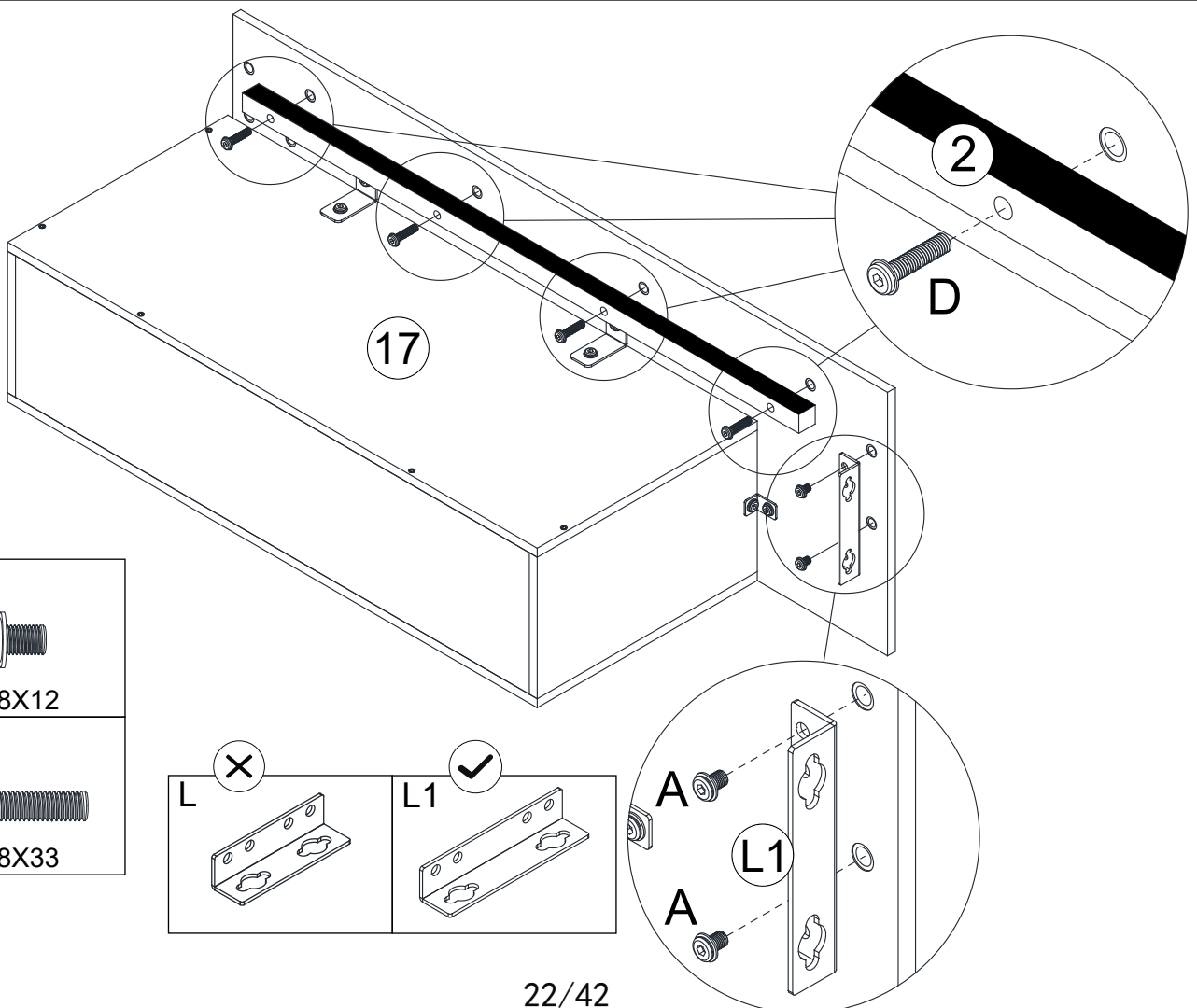

22

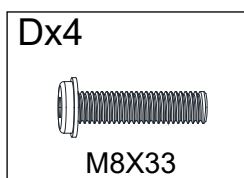
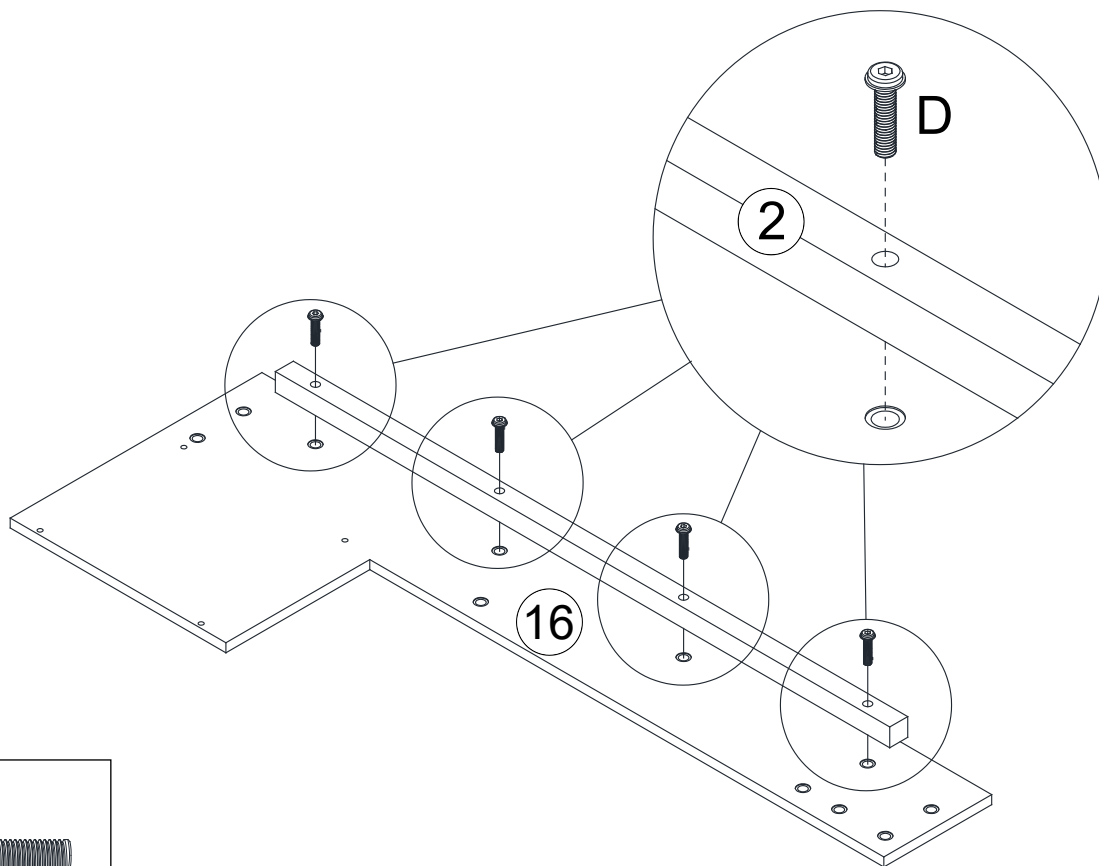

23

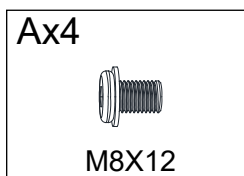
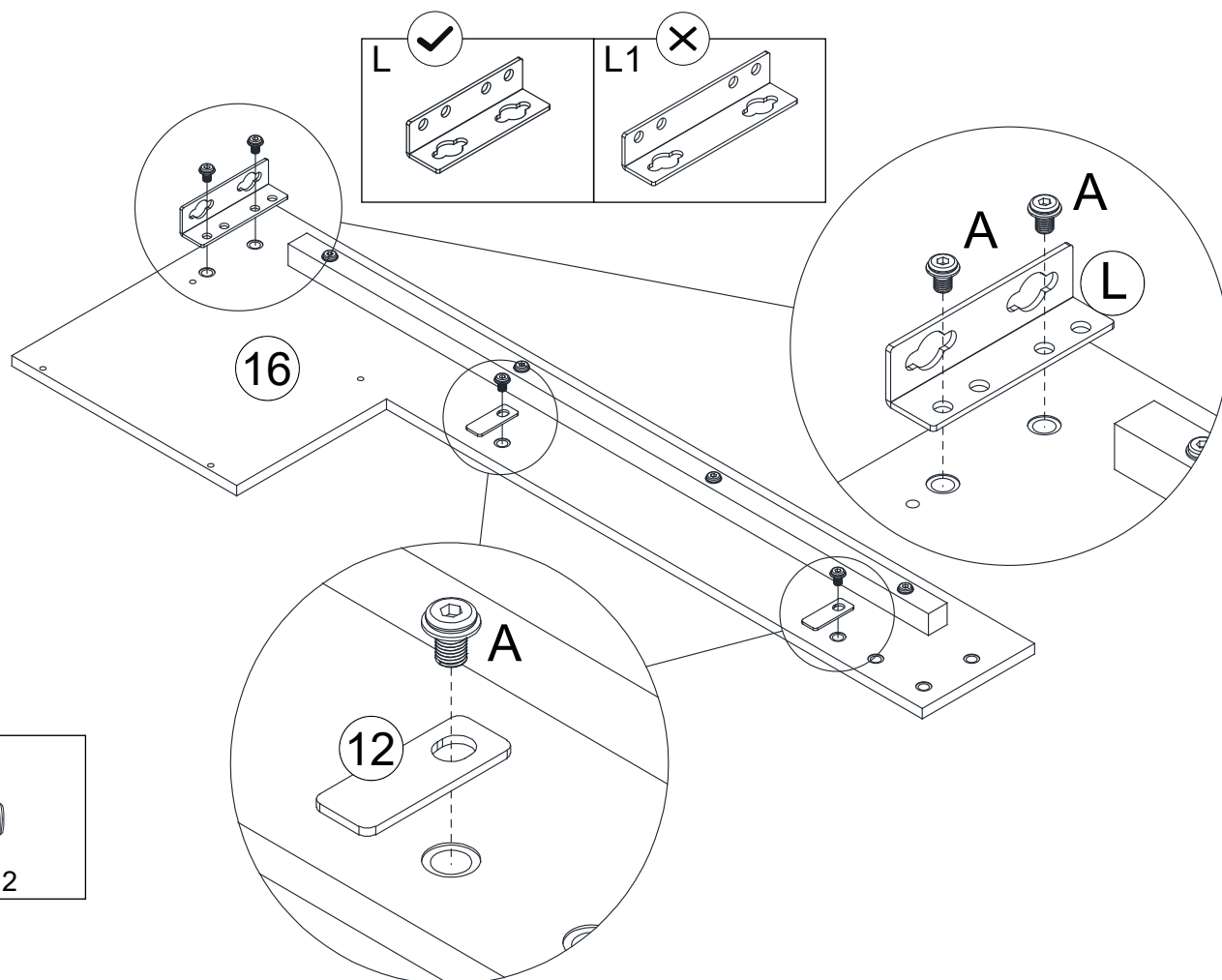

24

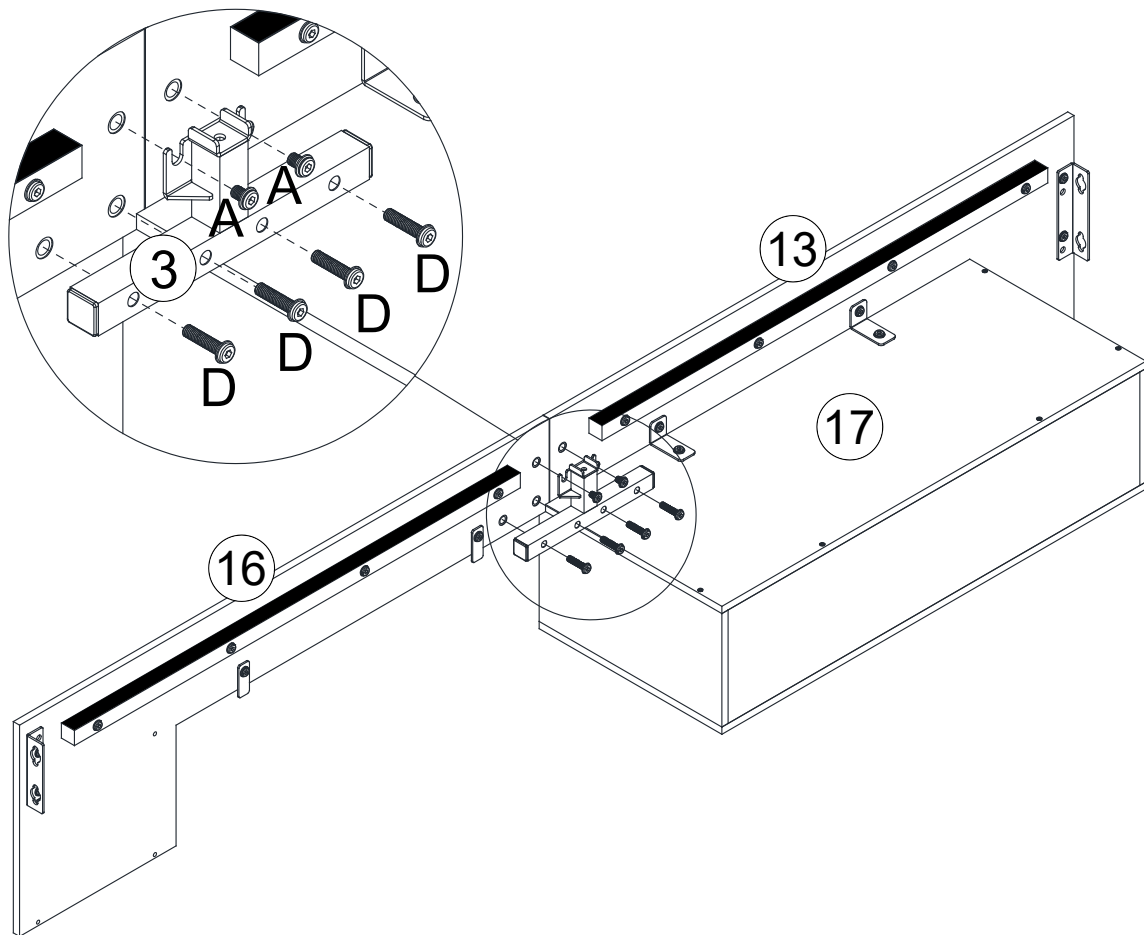

Ax2



M8X12

Dx4



M8X33

25

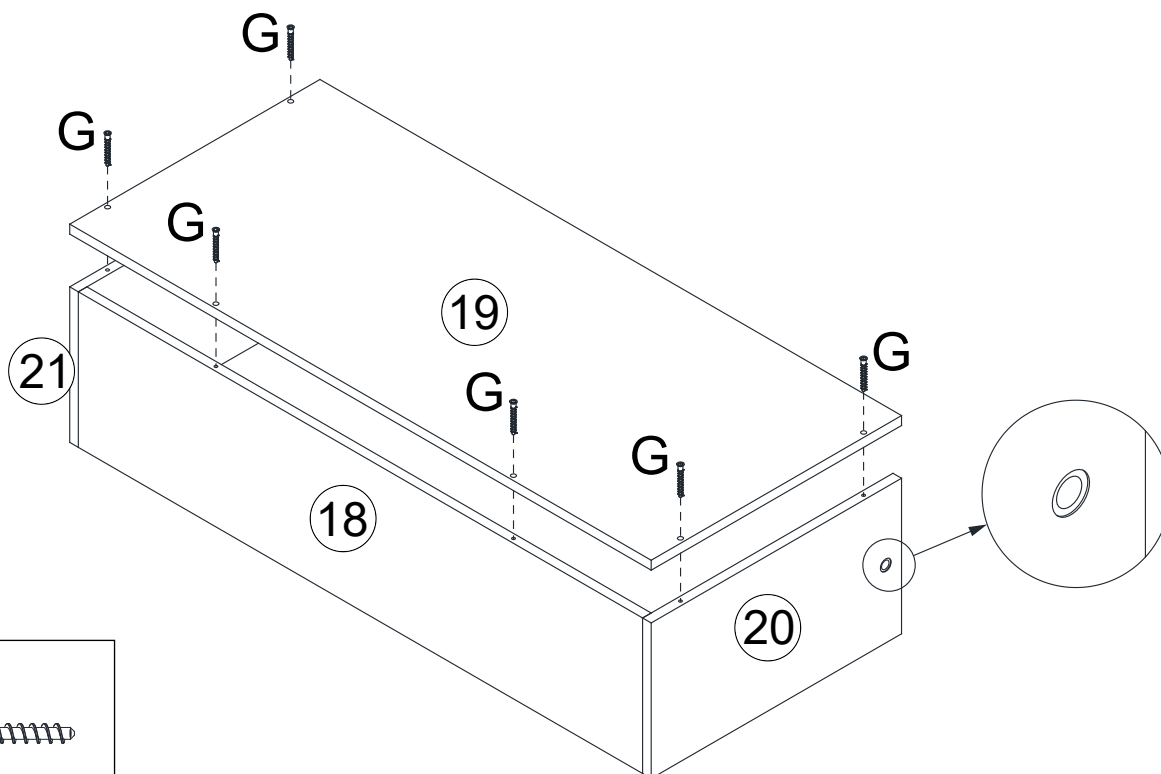

Gx6



M5X40

26

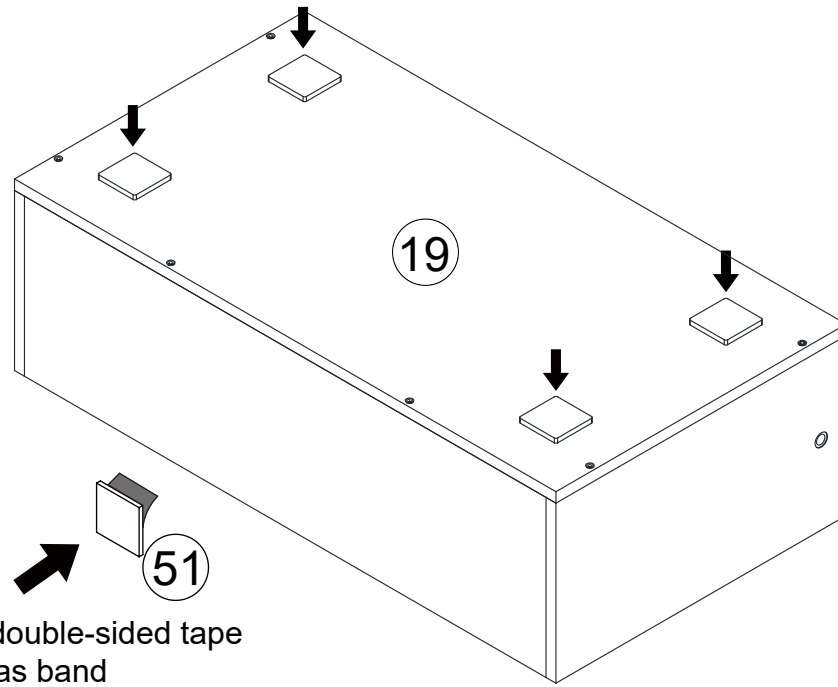

Tear the double-sided tape
Zerrei das band
Dchirer la bande double face
Strappamento del nastro adesivo
Rasgar cinta doble cara

27

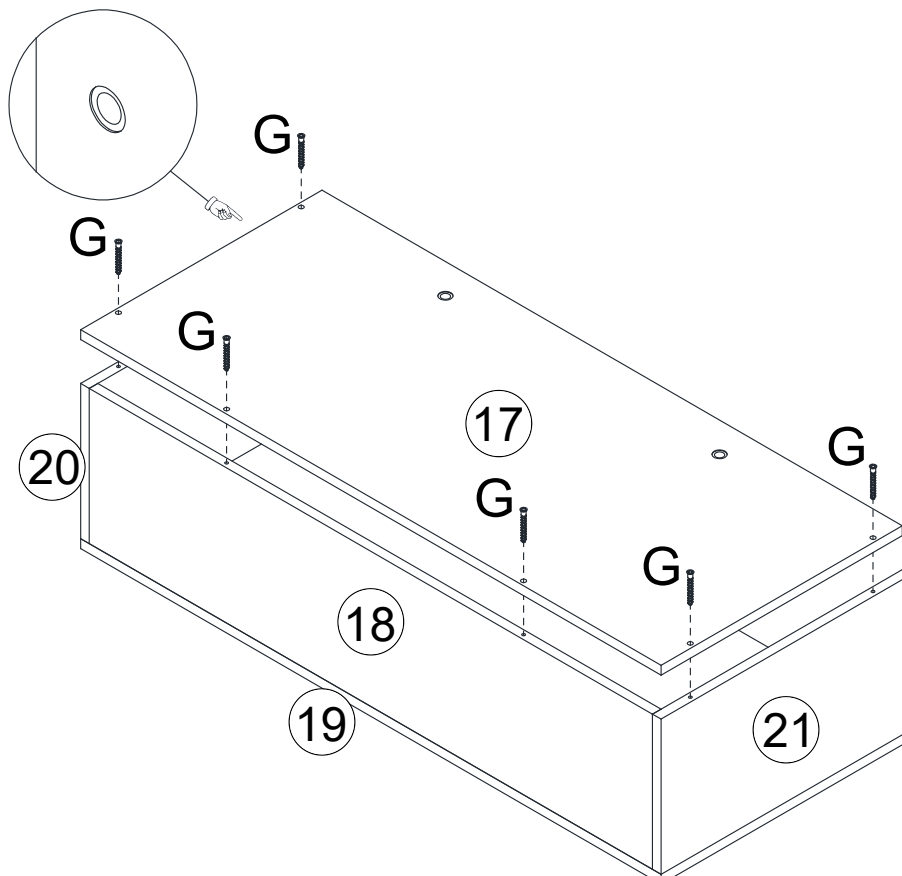

28

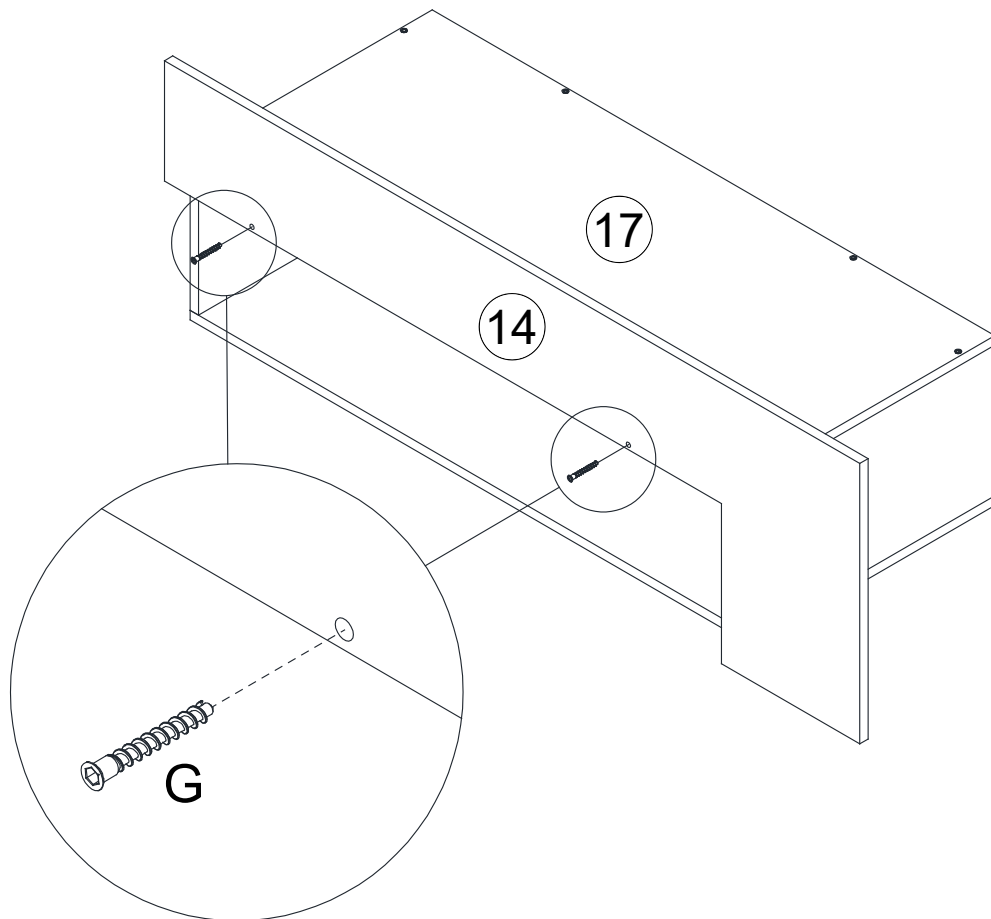

29

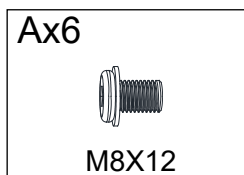
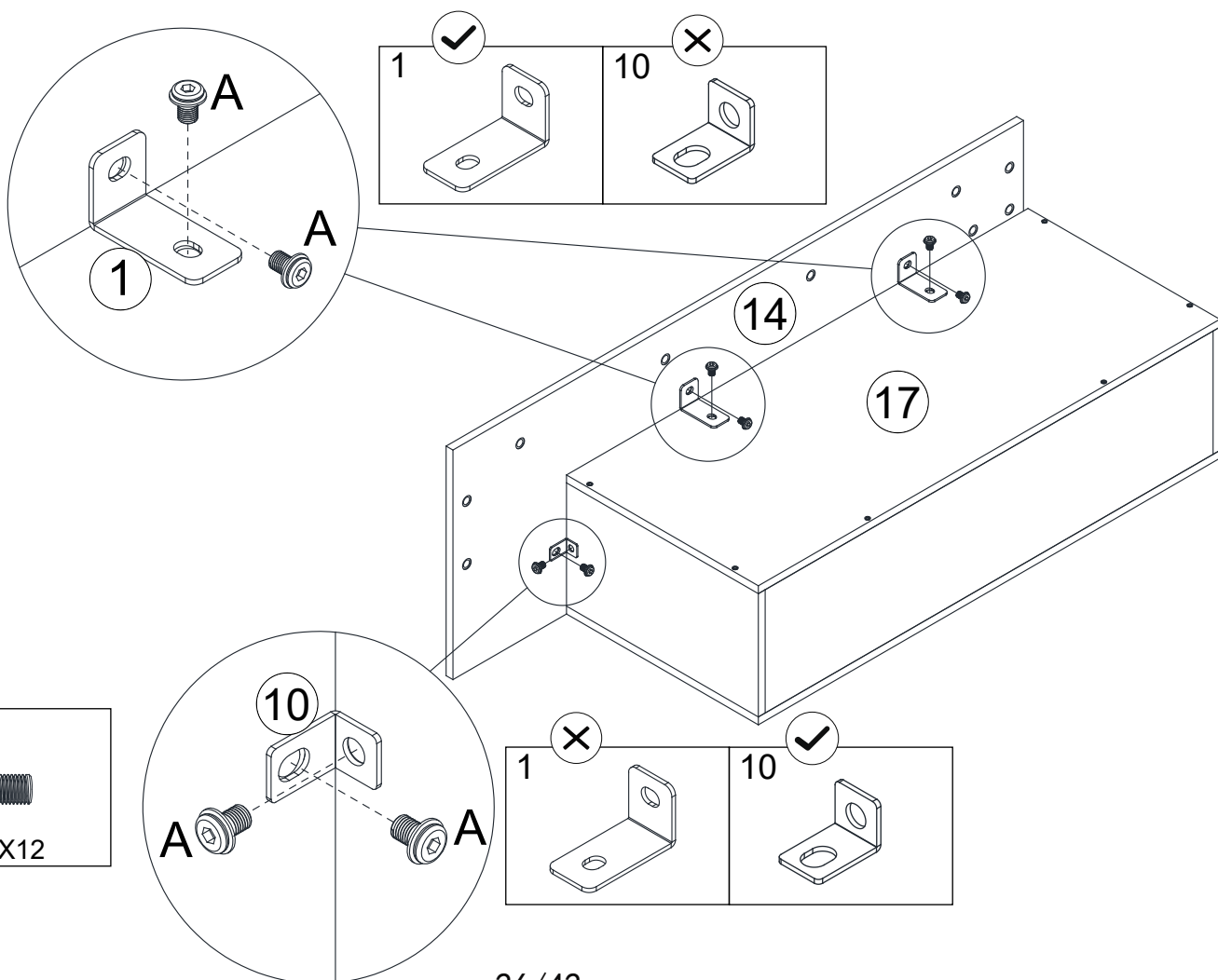

30

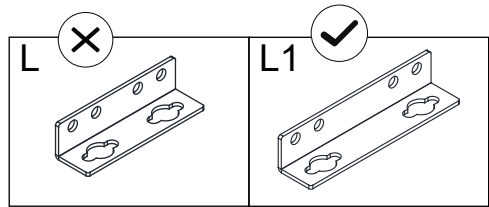
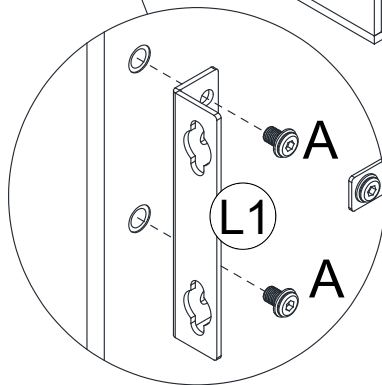
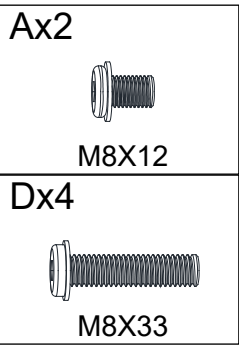
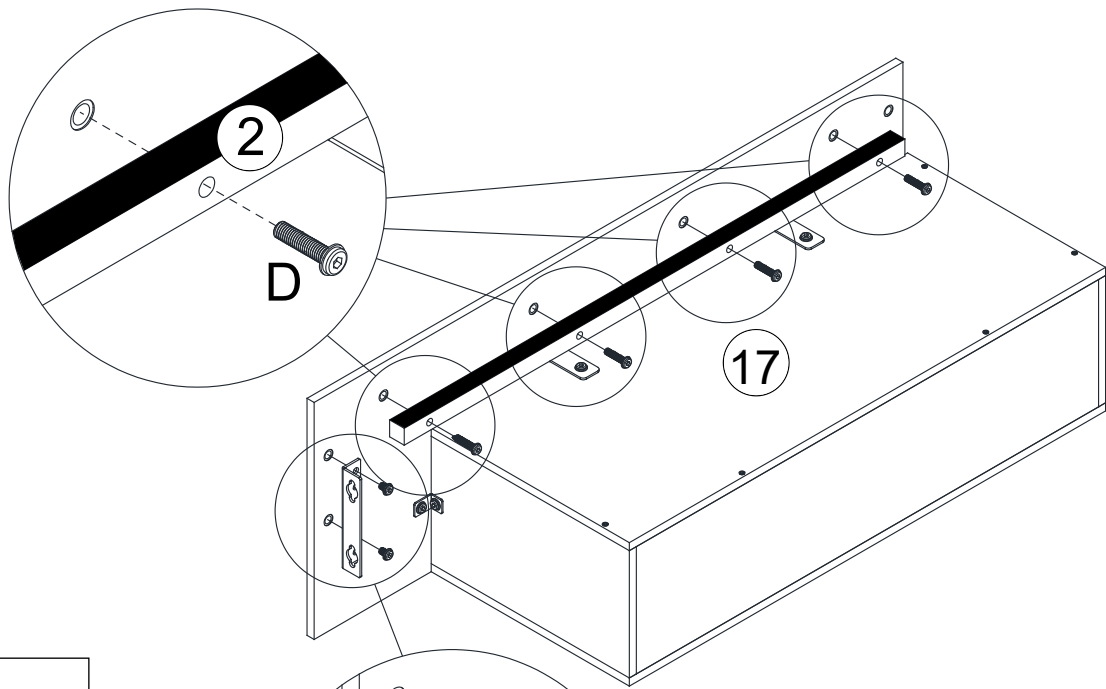

31

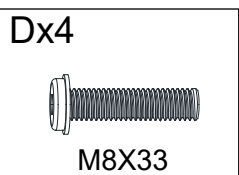
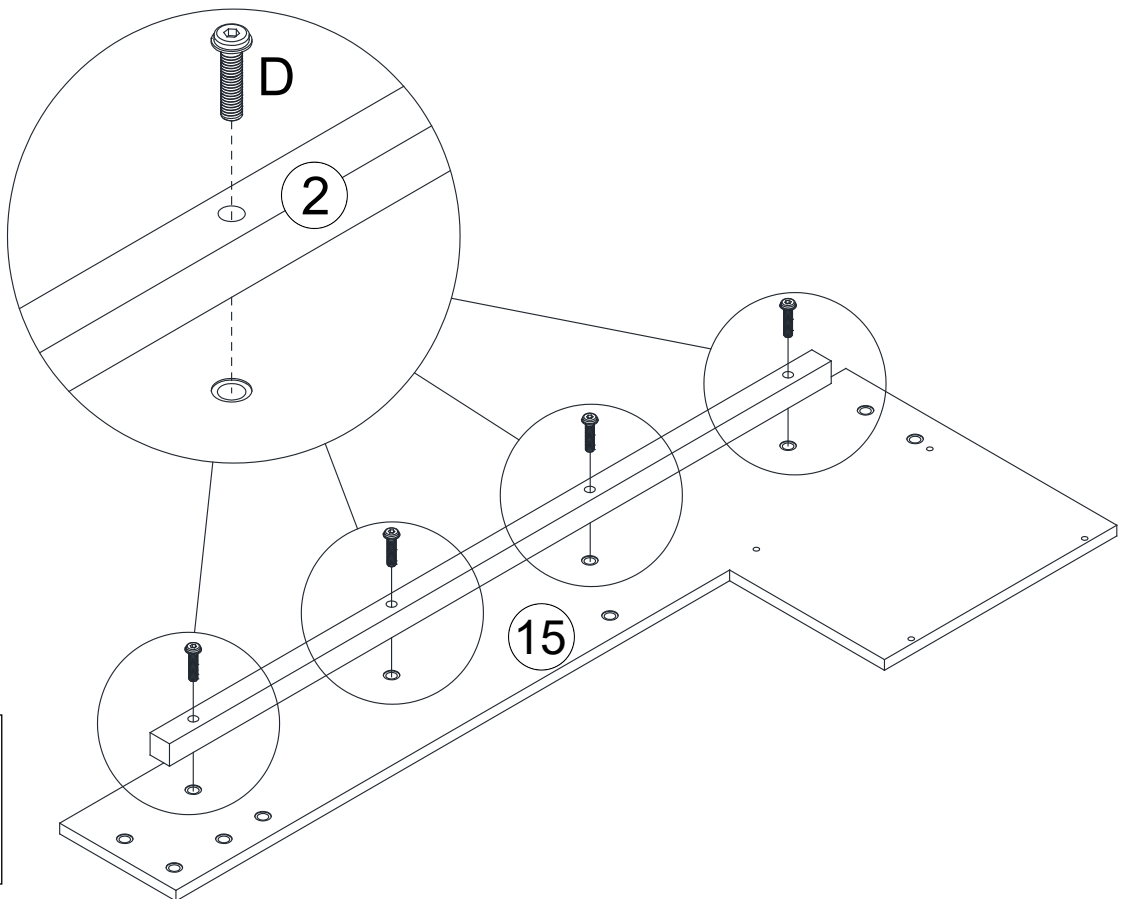

32

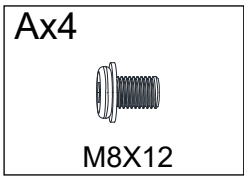
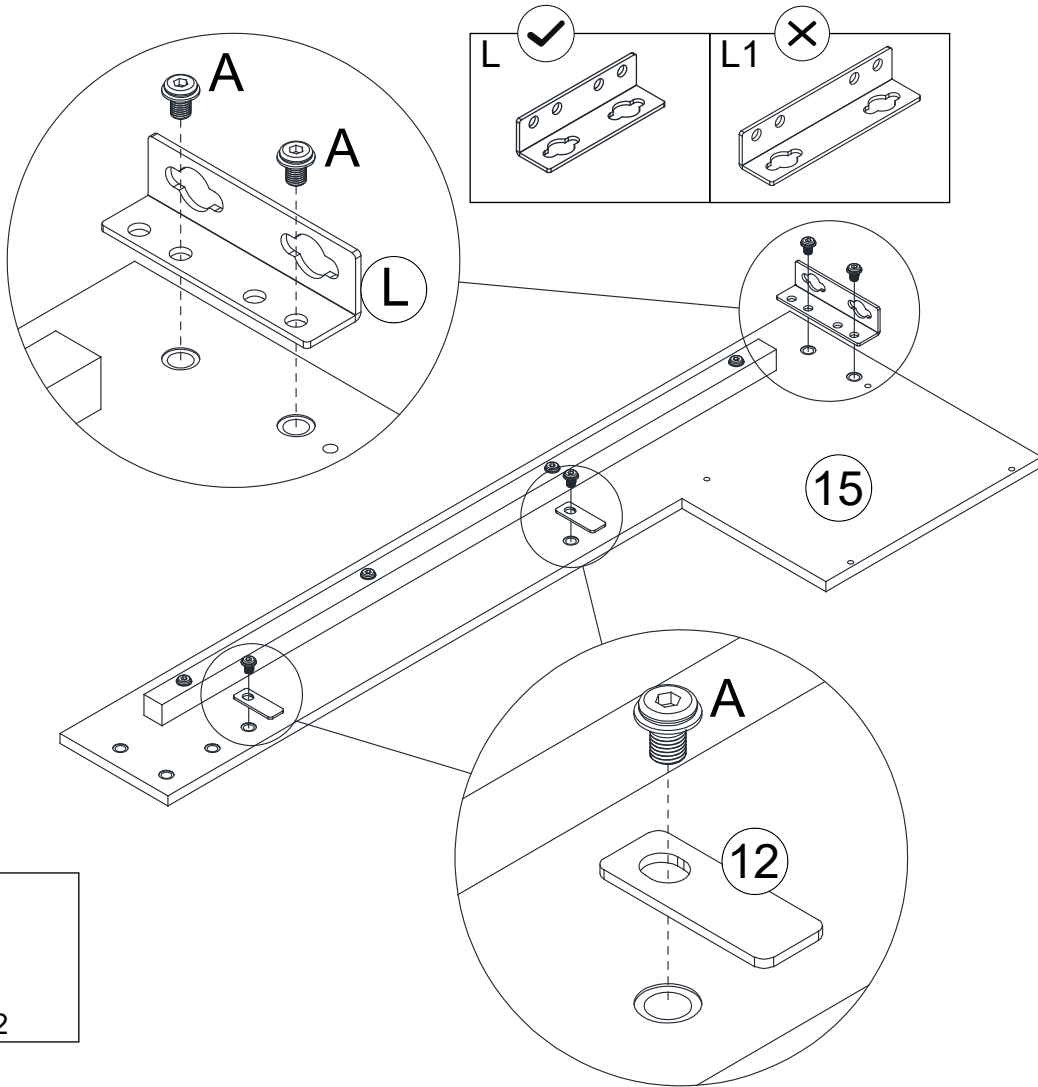

33

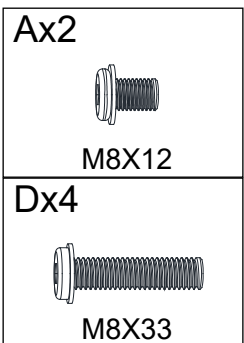
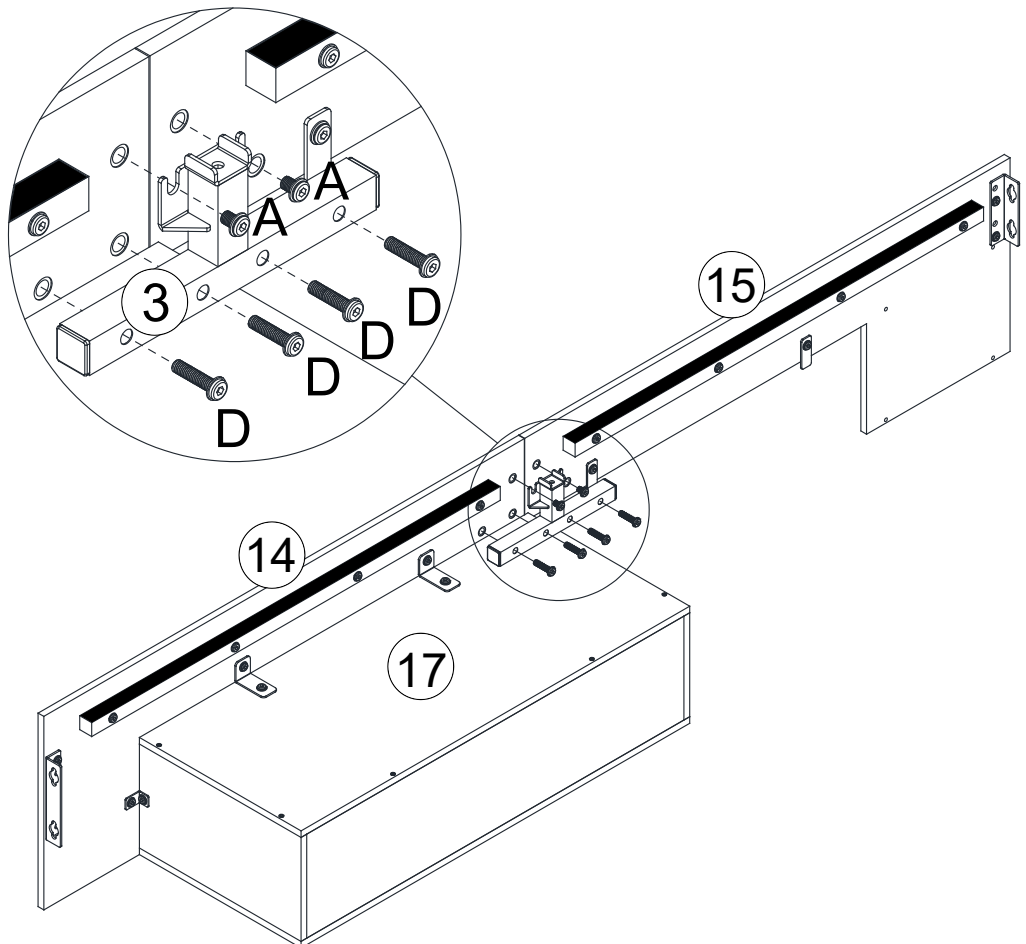

34

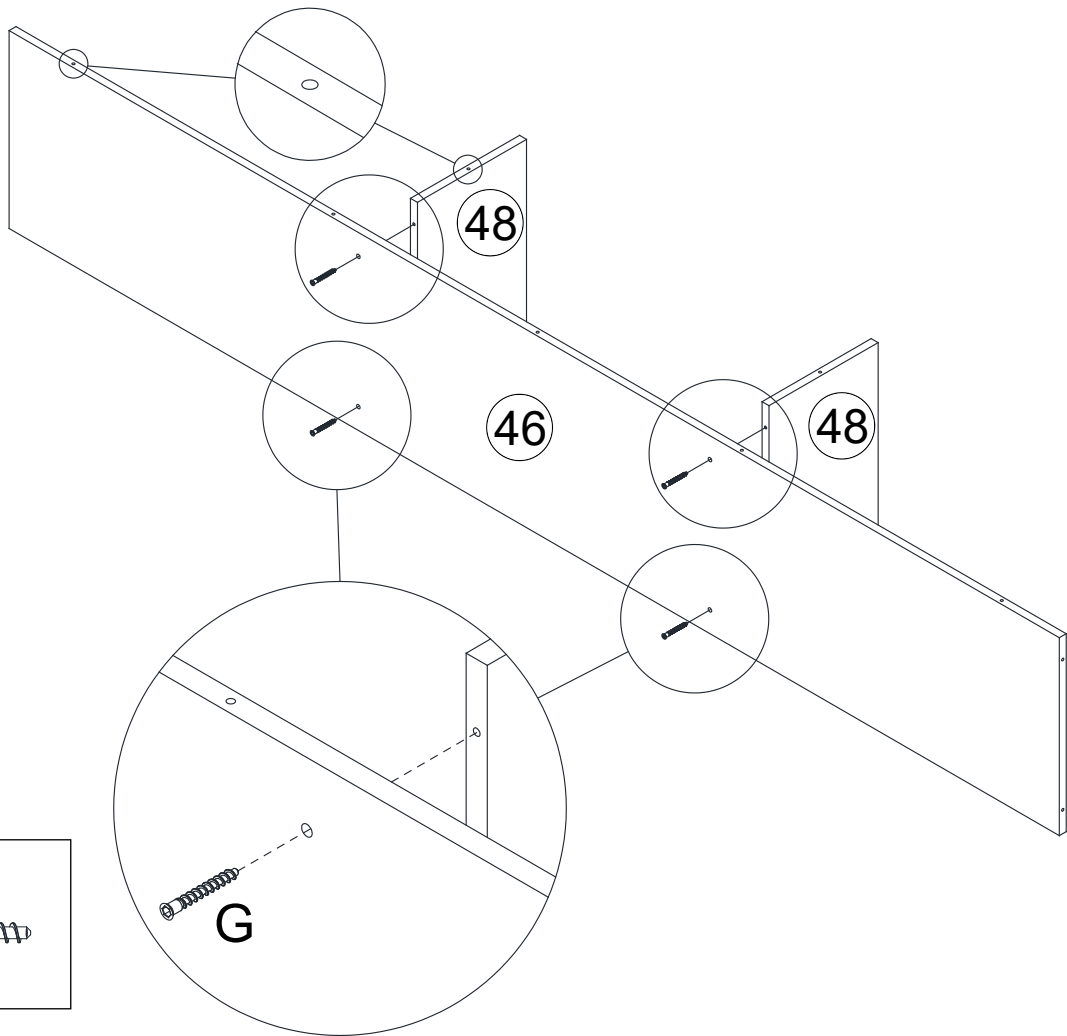

35

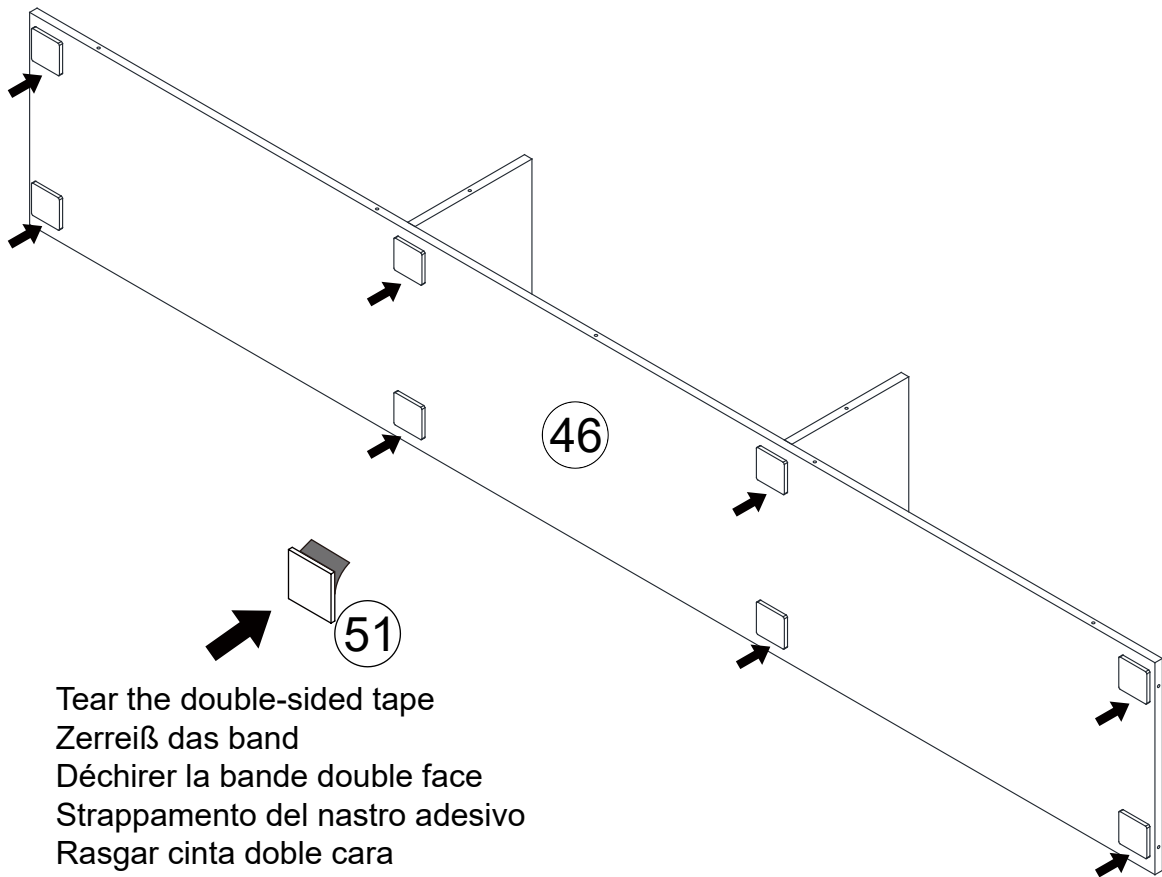

36

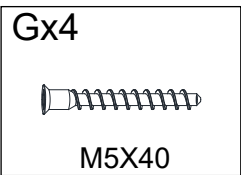
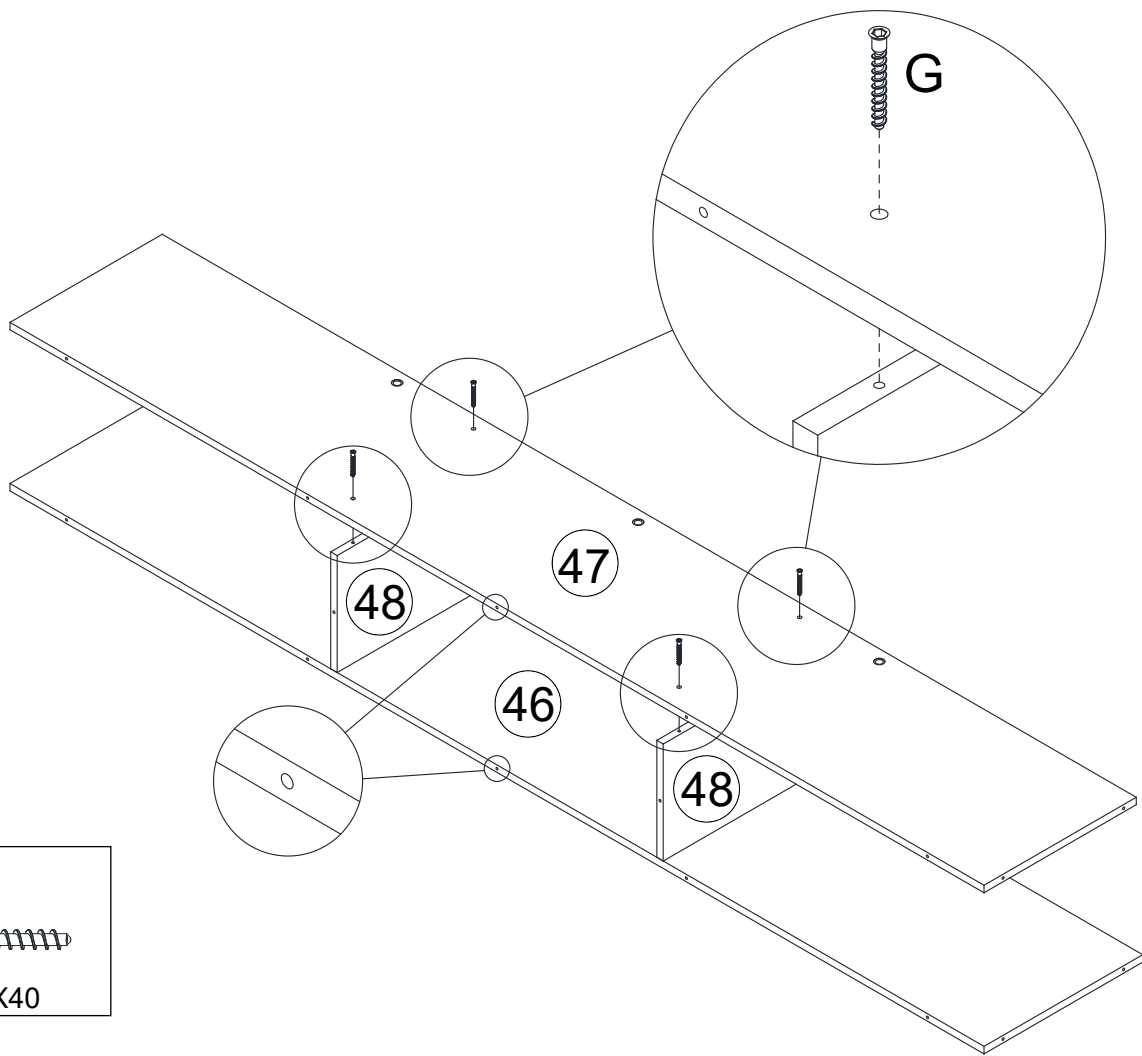

37

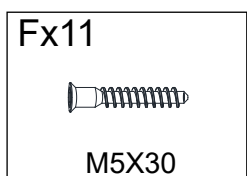
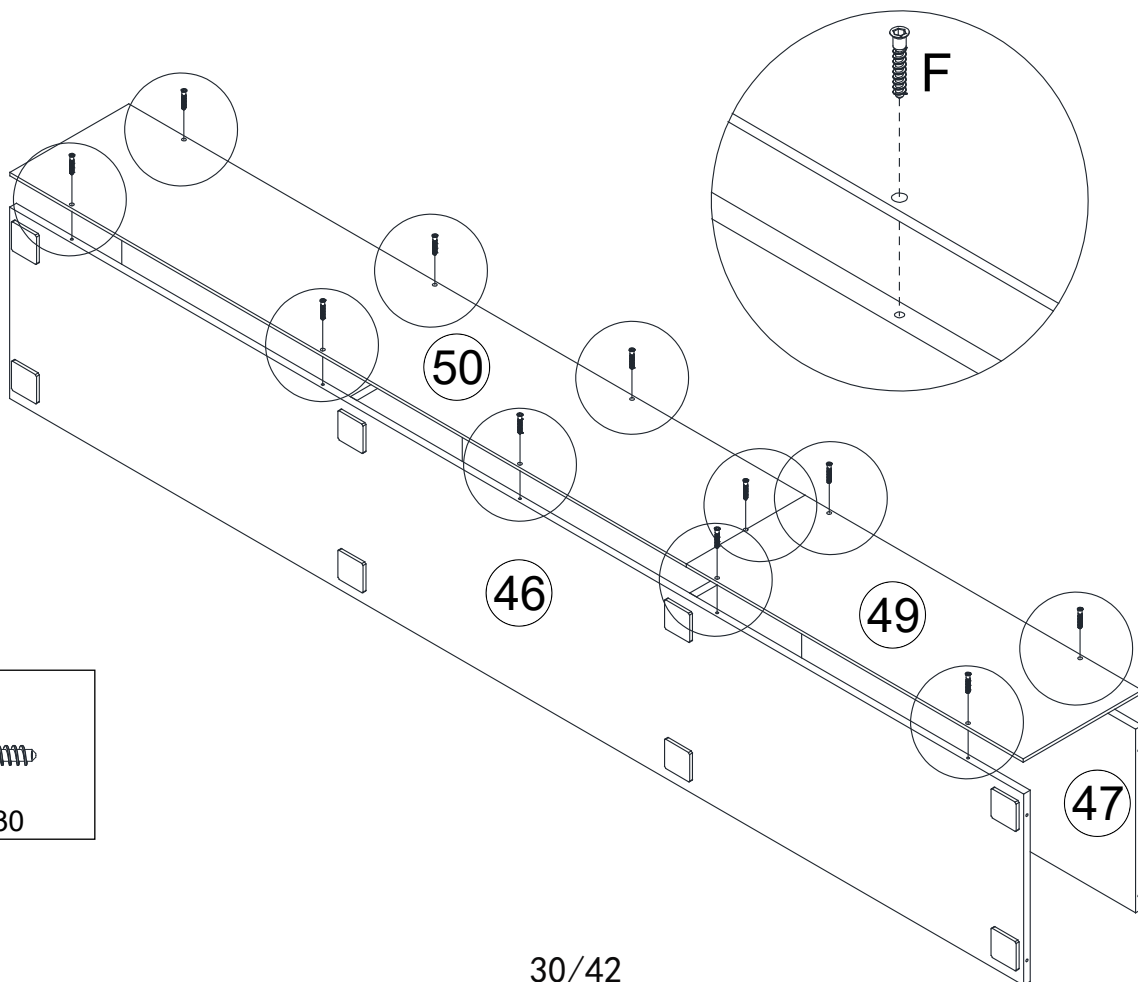

38

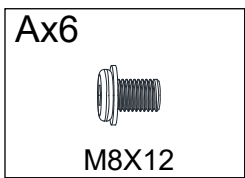
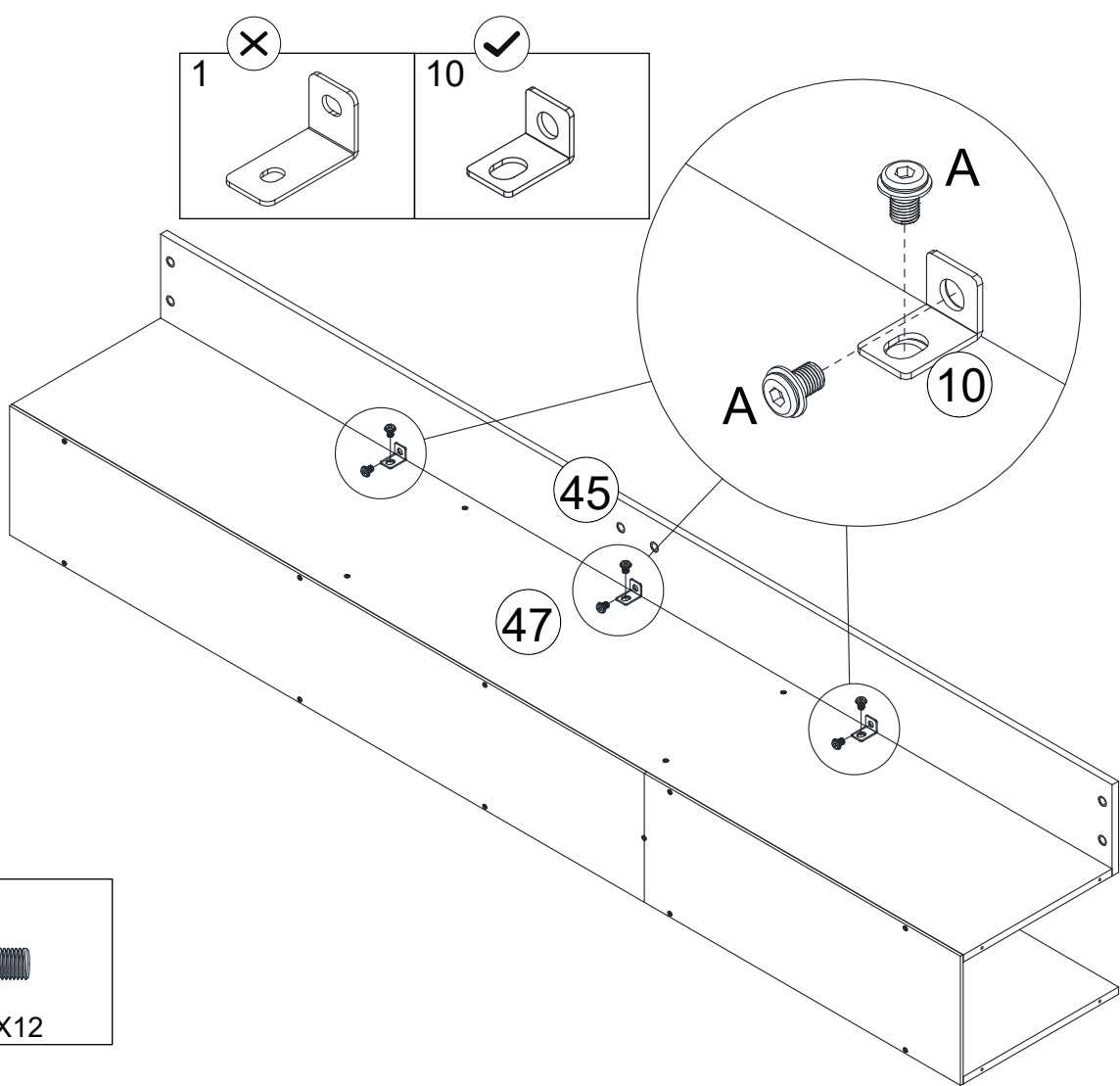

39

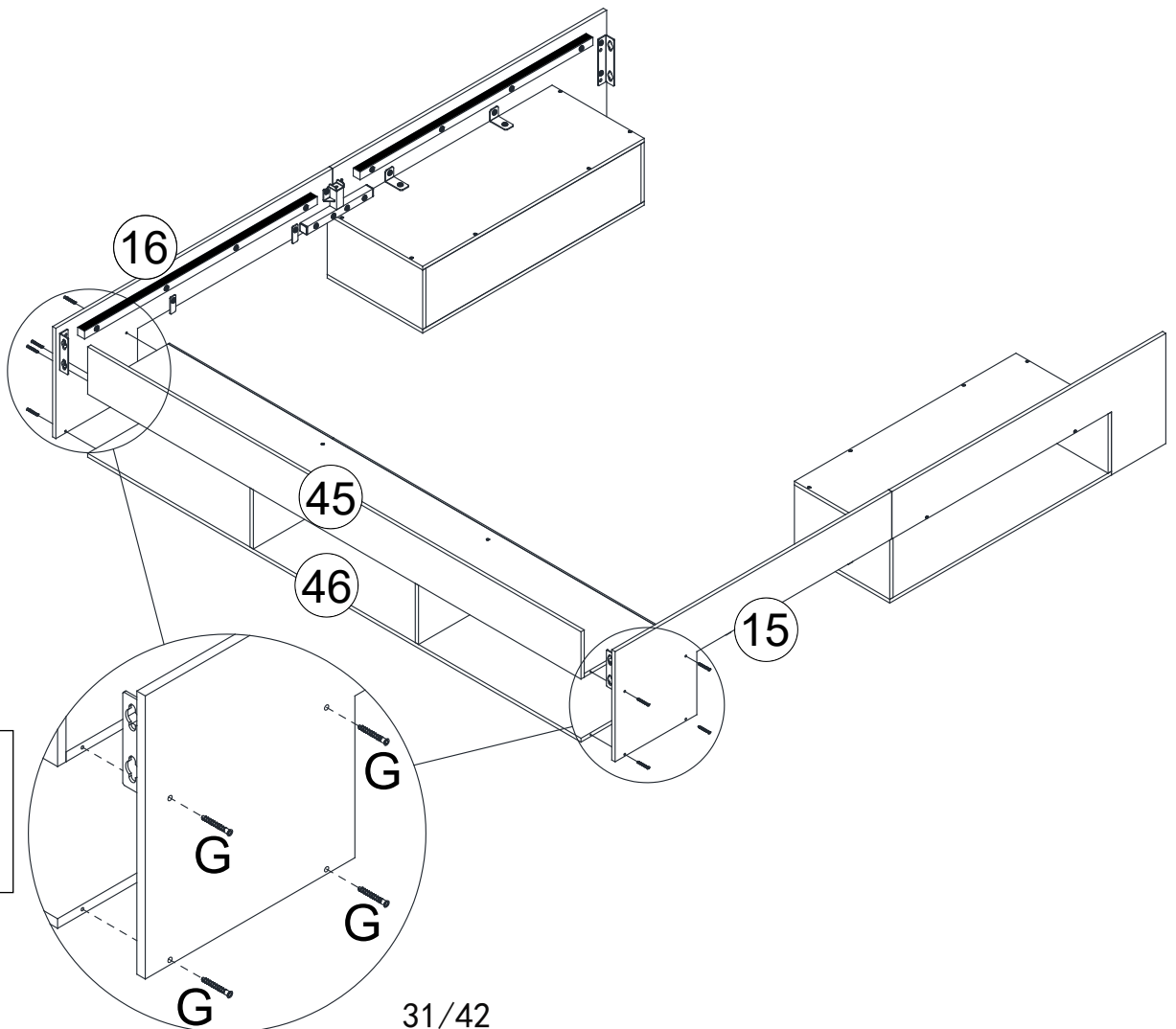

40

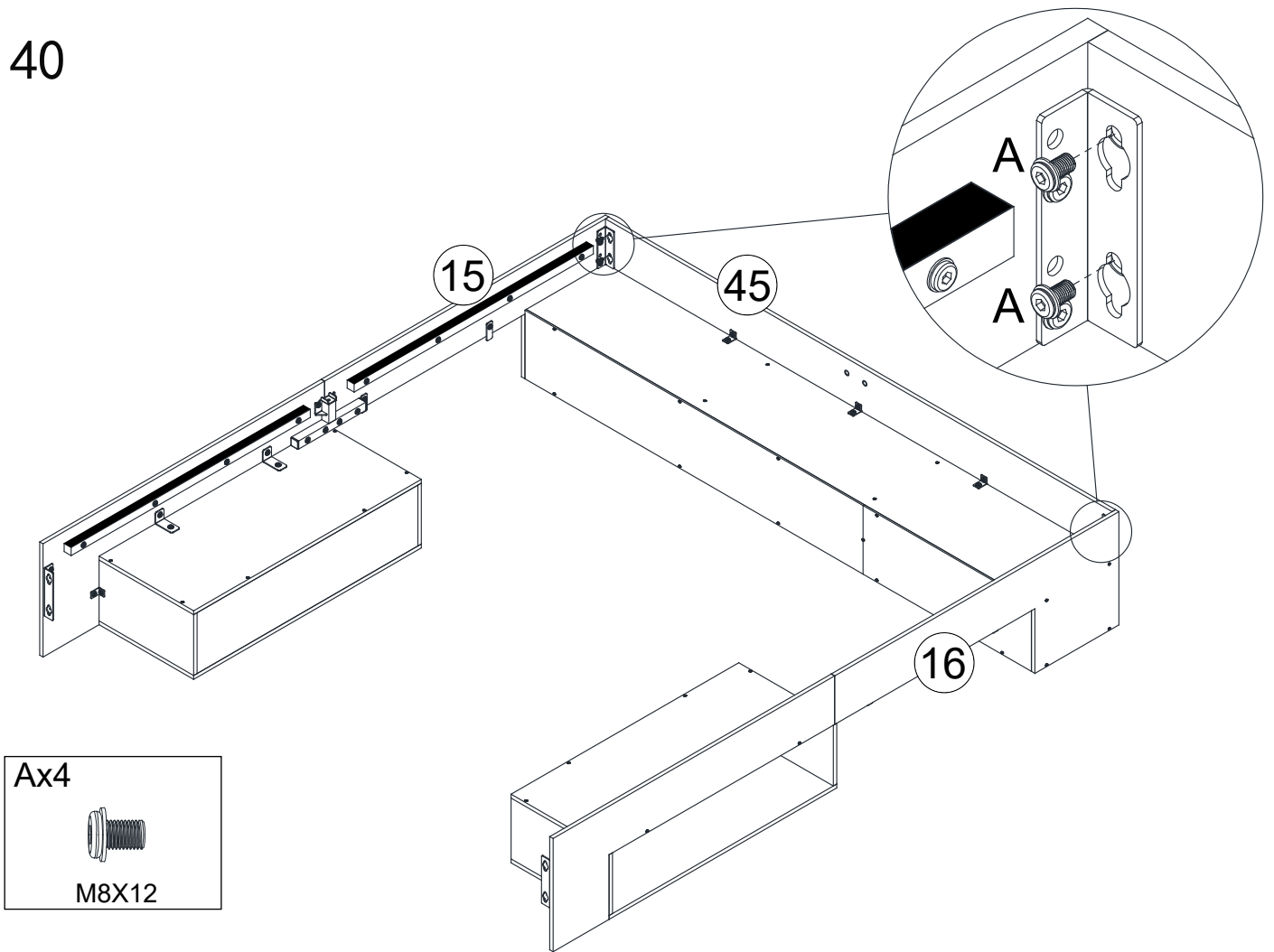

41

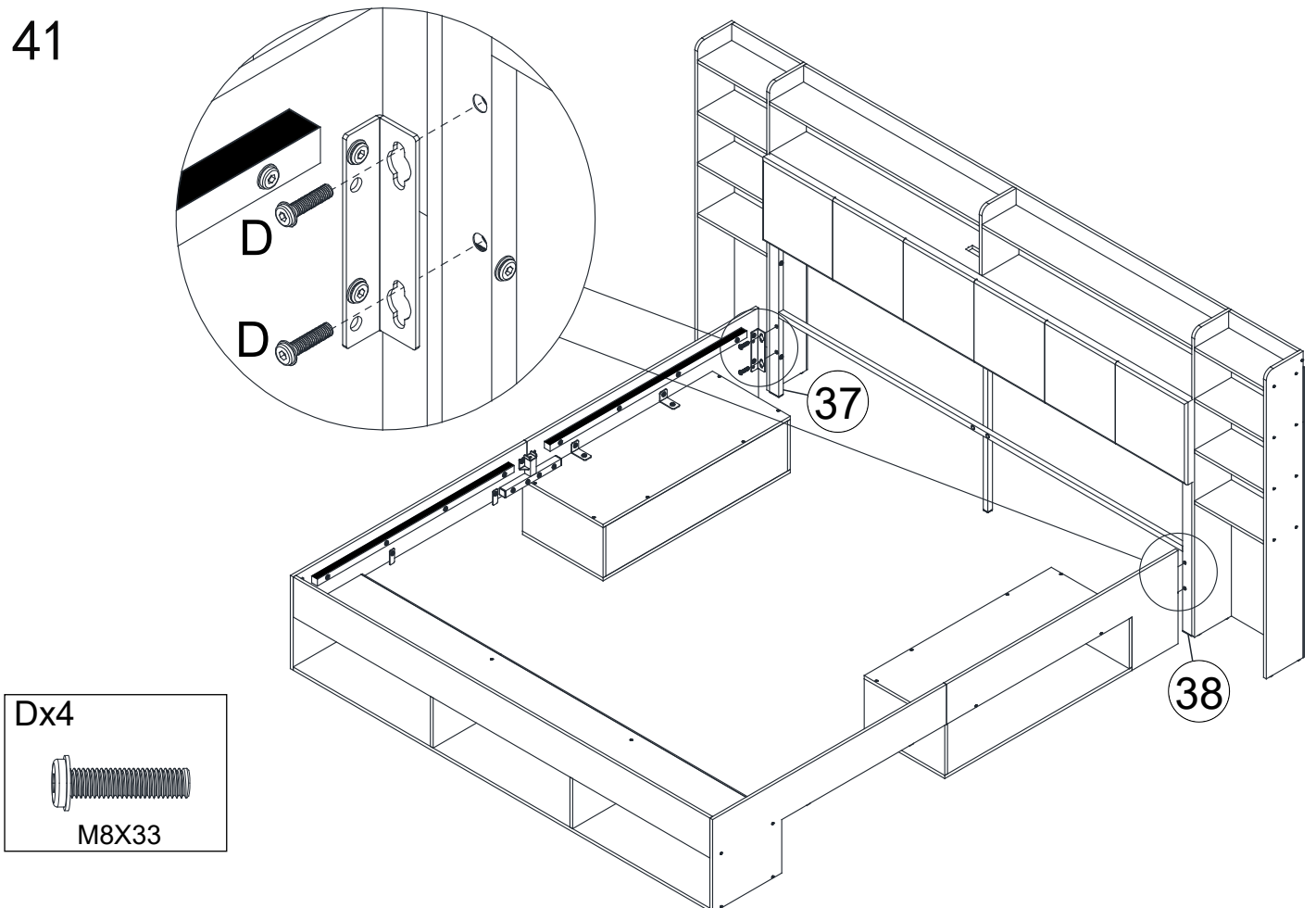

42

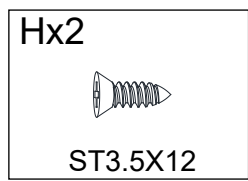
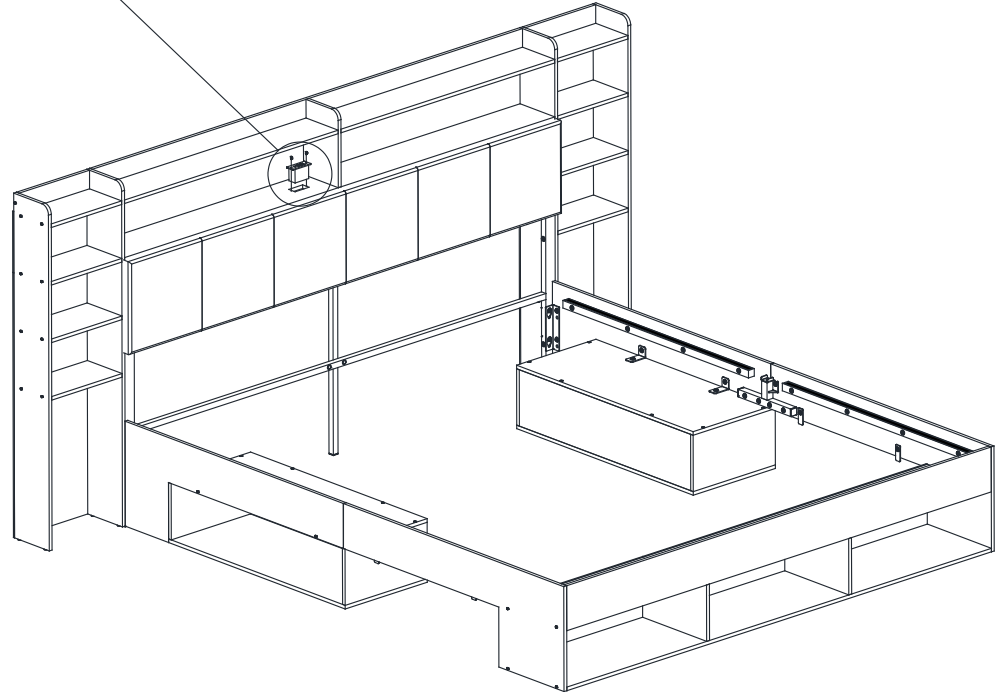
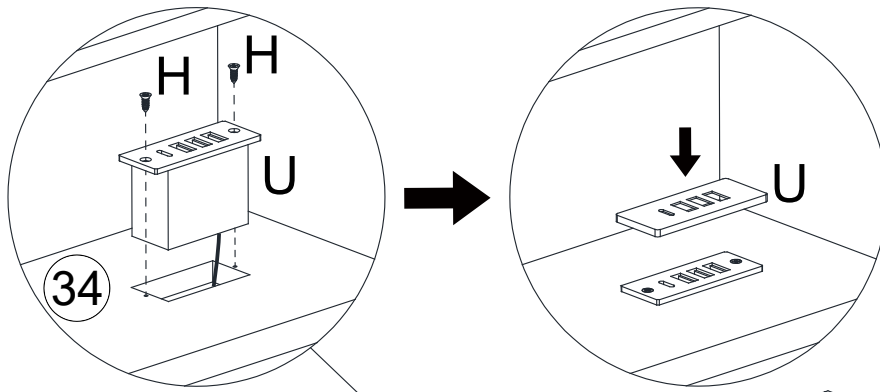

43

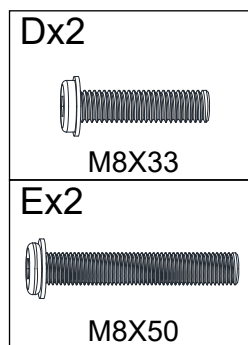
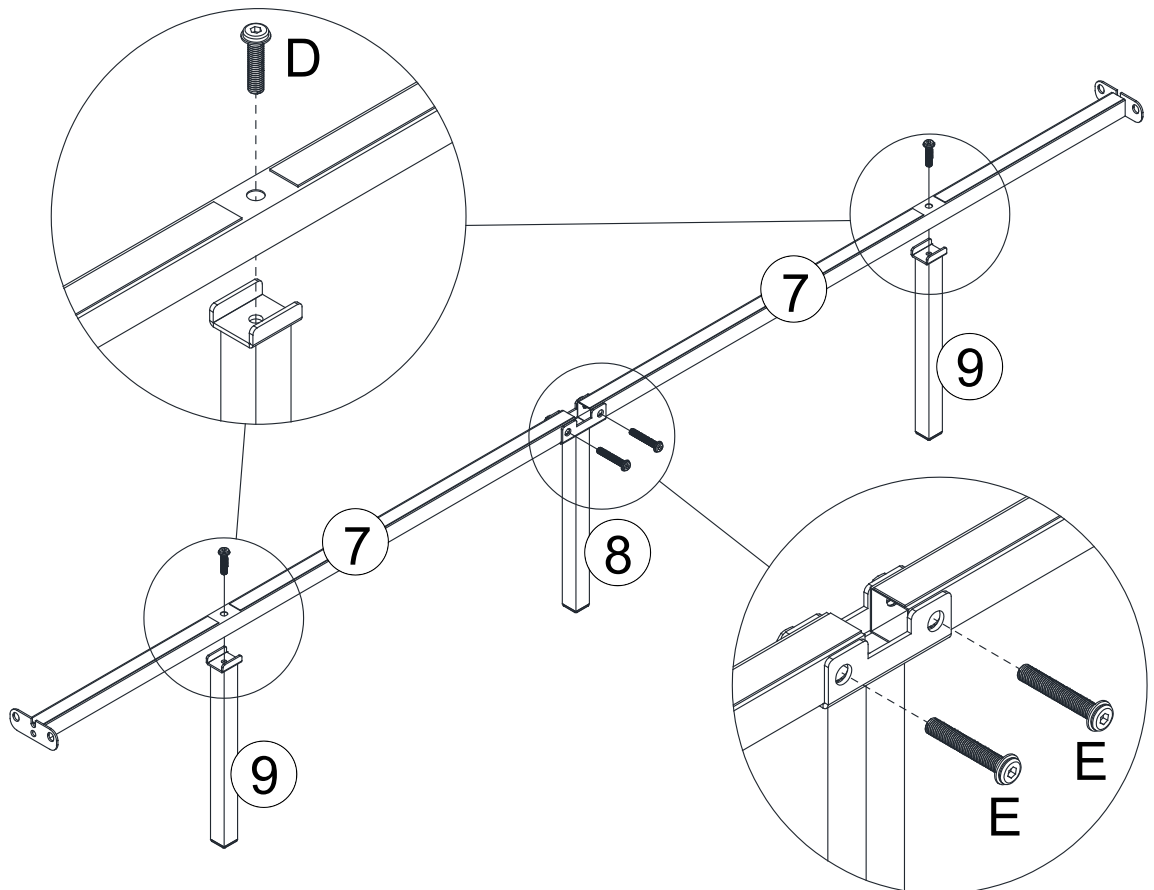

44

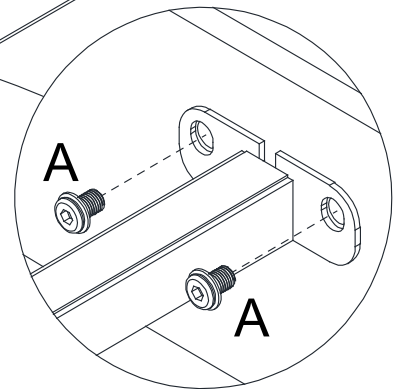
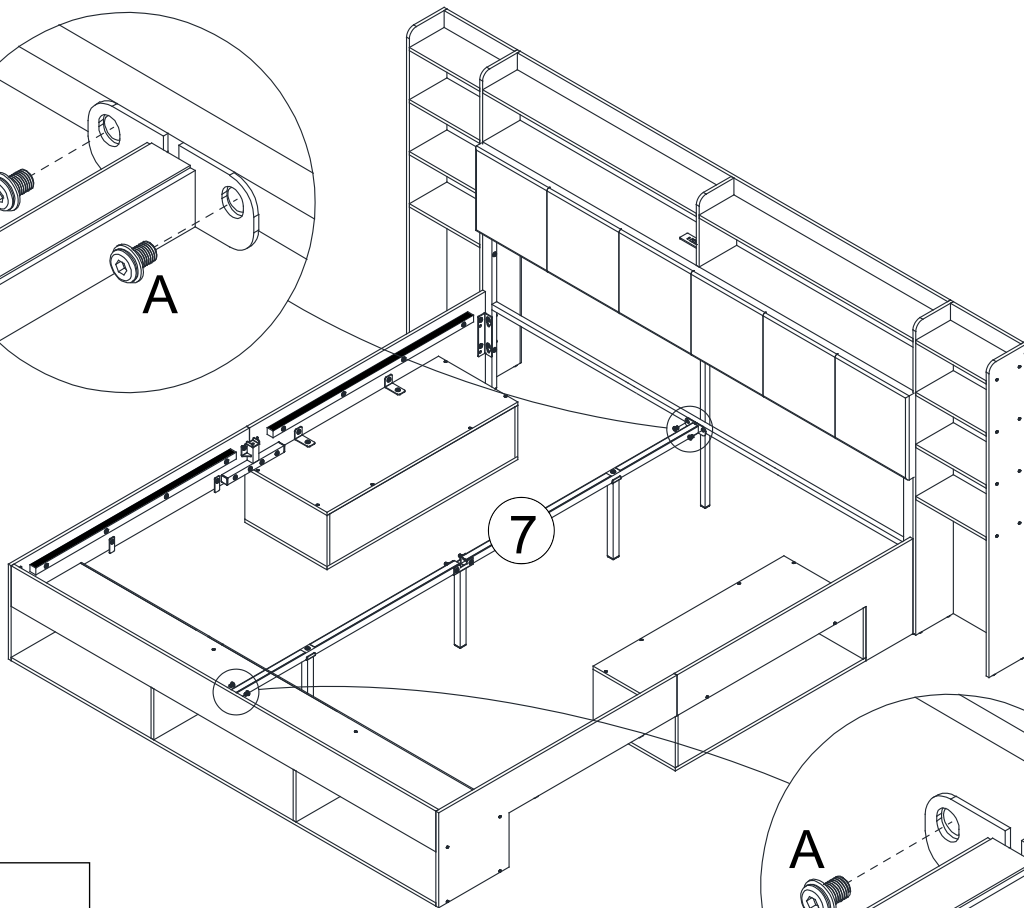
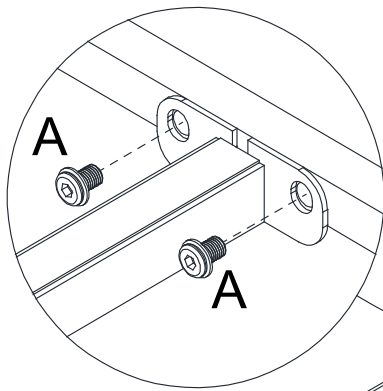

Ax4



M8X12

45

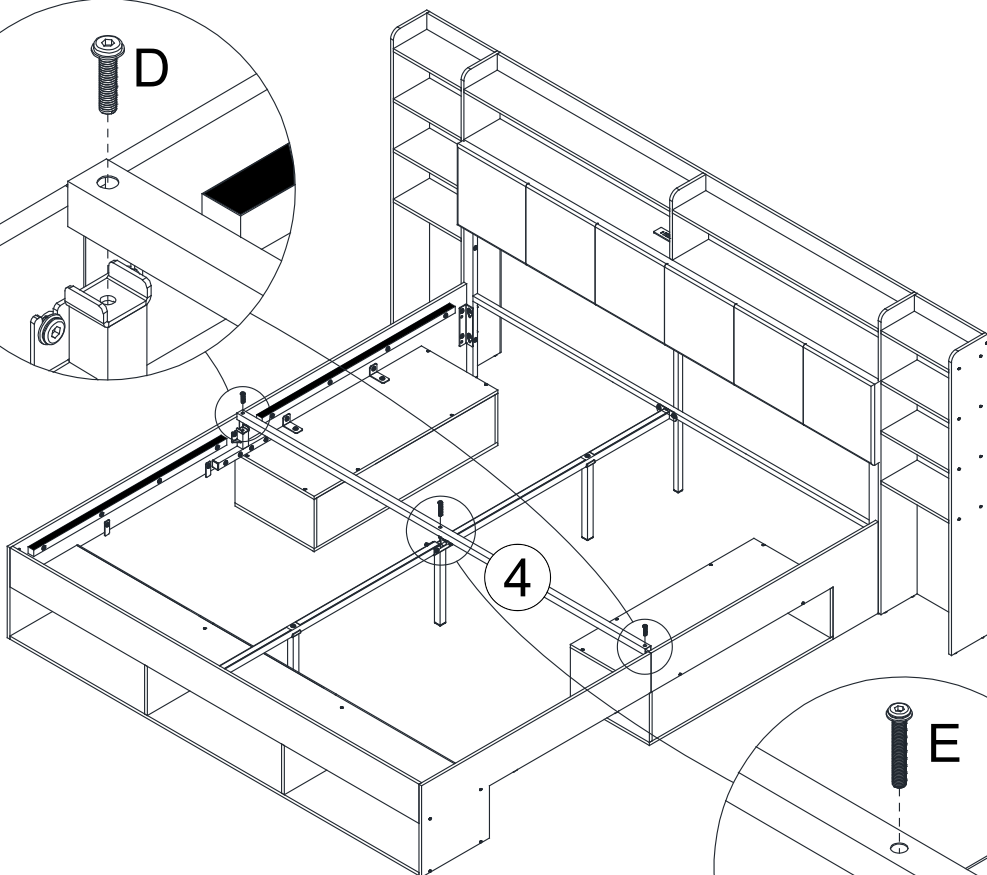
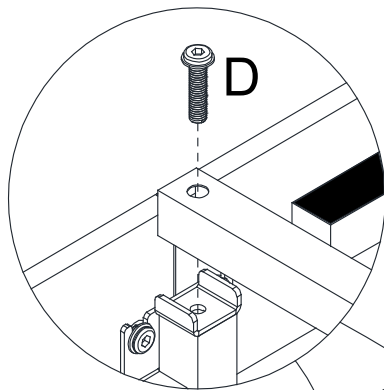

Dx2



M8X33

Ex1



M8X50

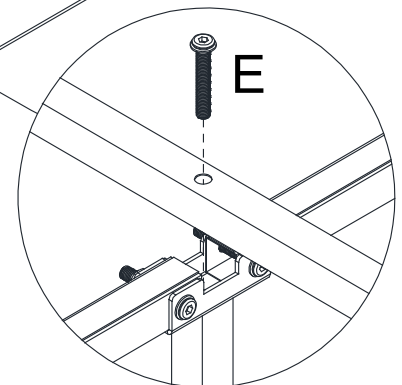

46

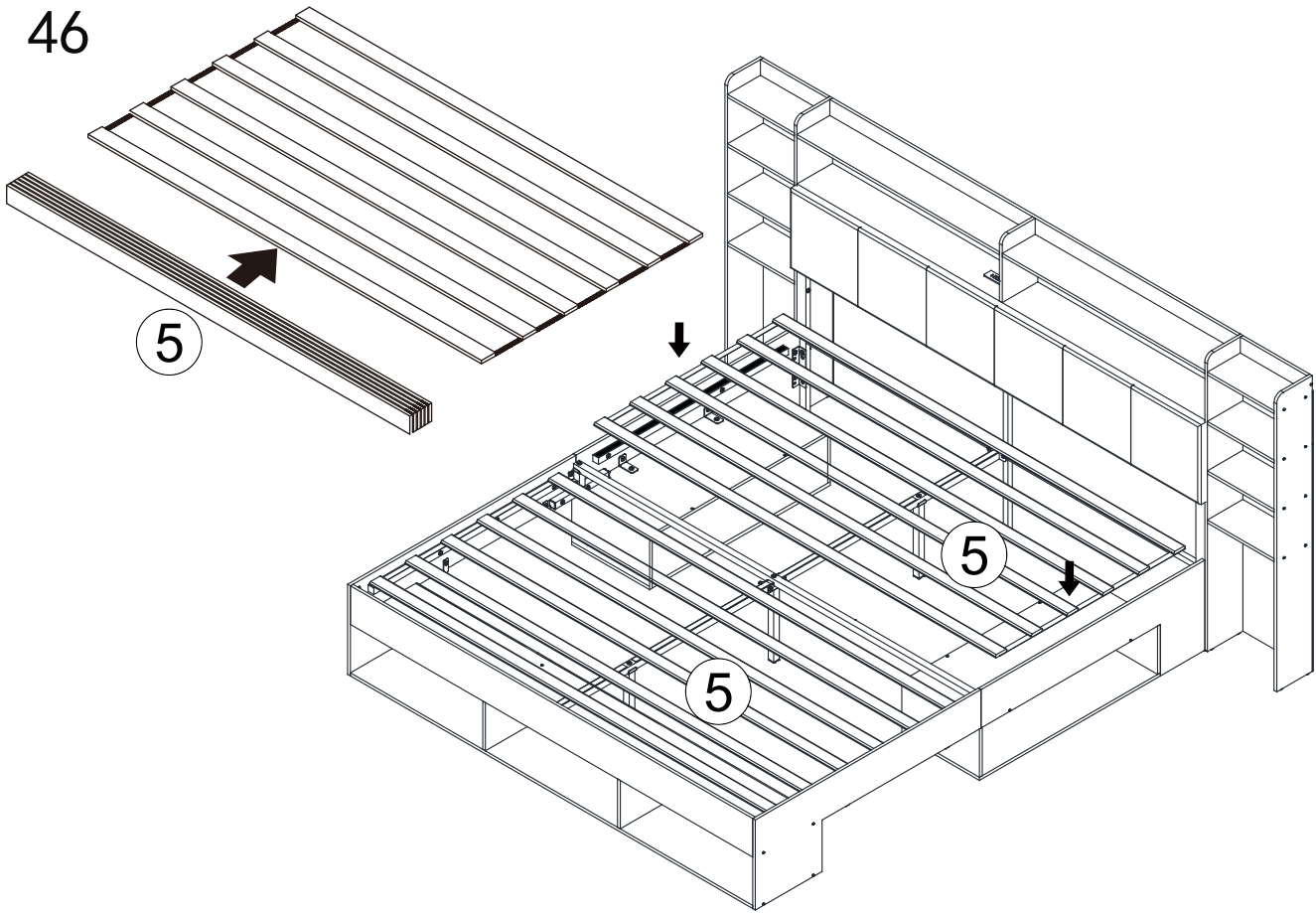

47X2

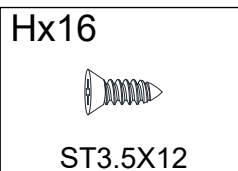
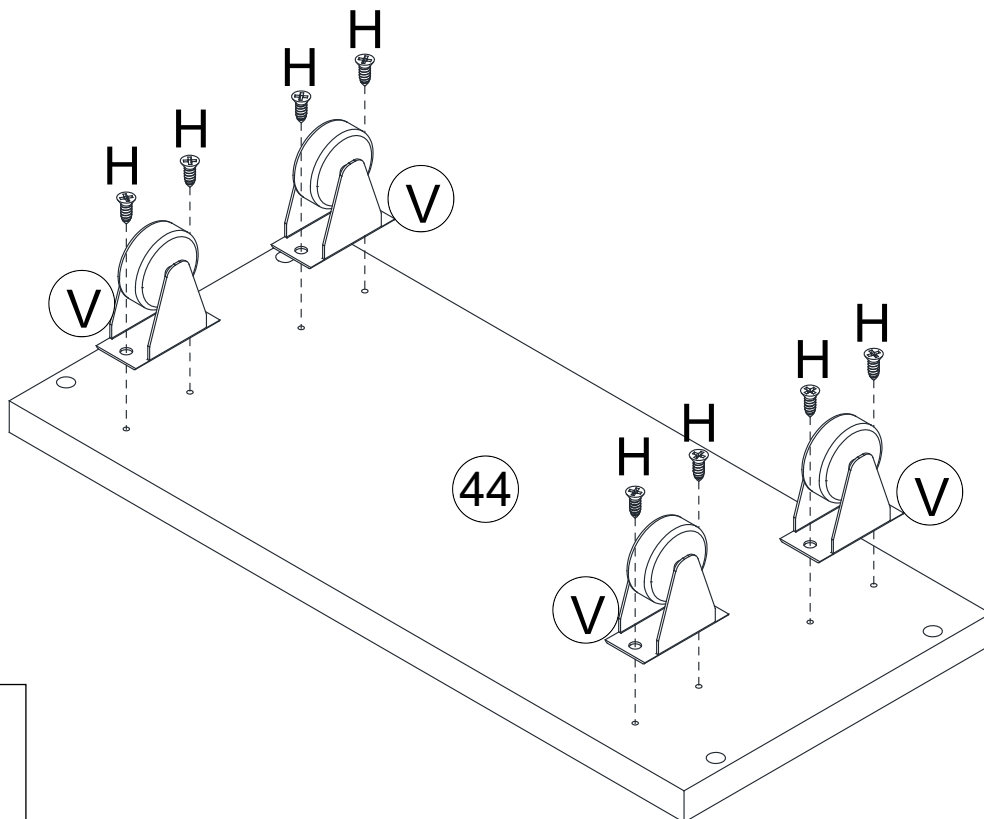

48X2

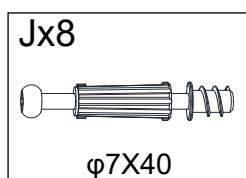
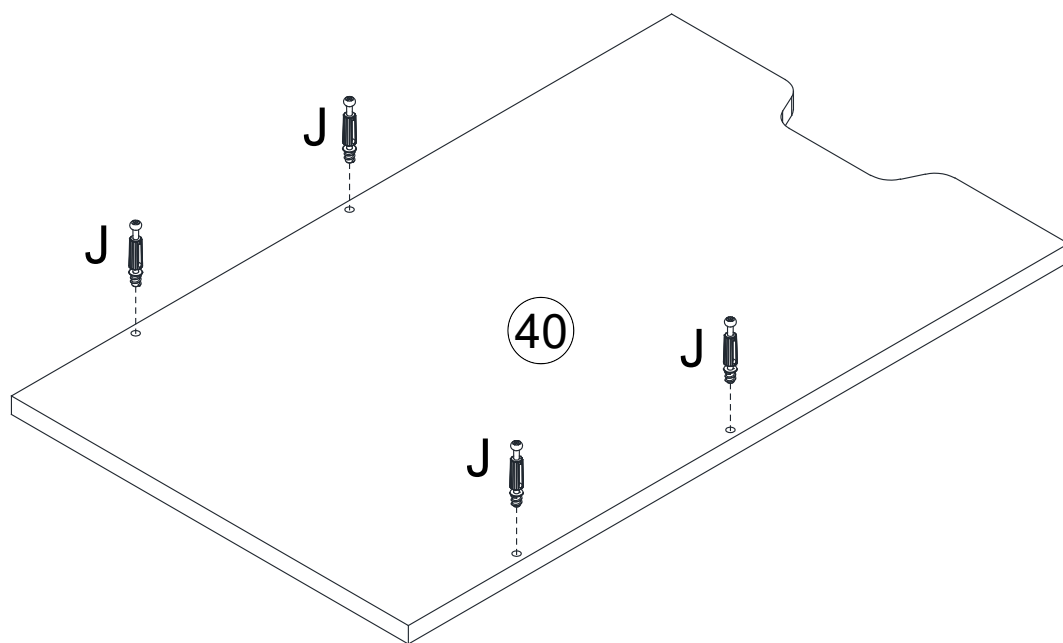

49X2

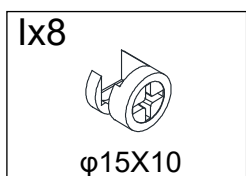
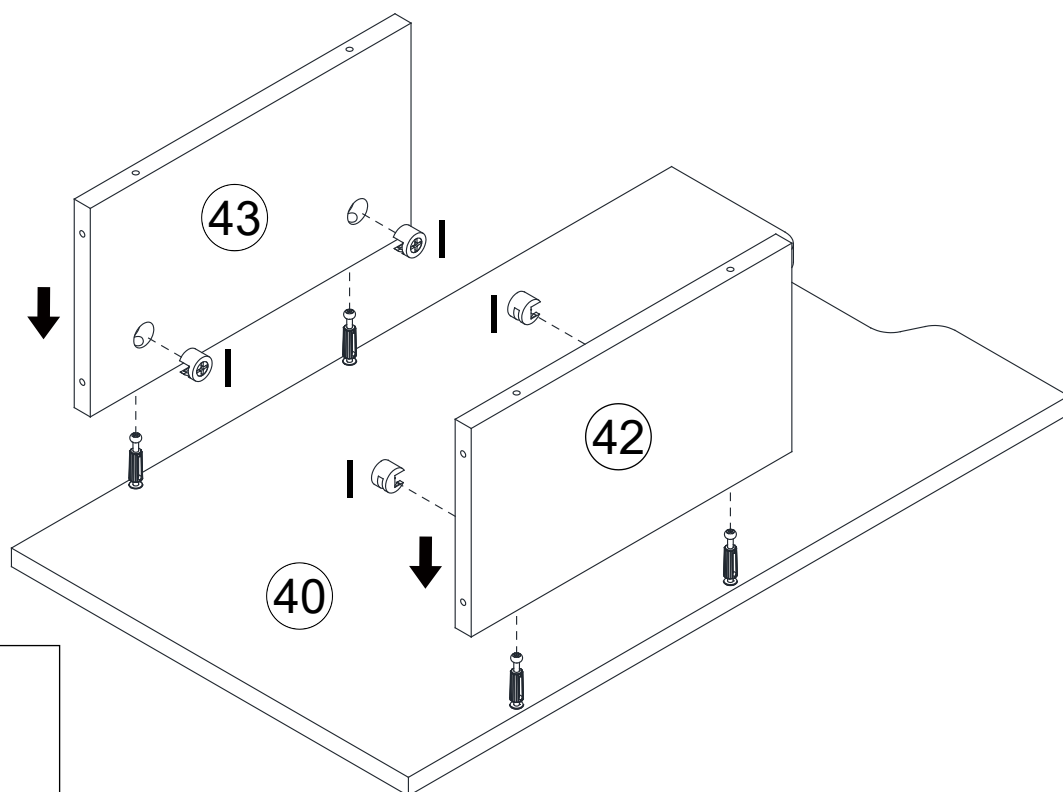

50X2

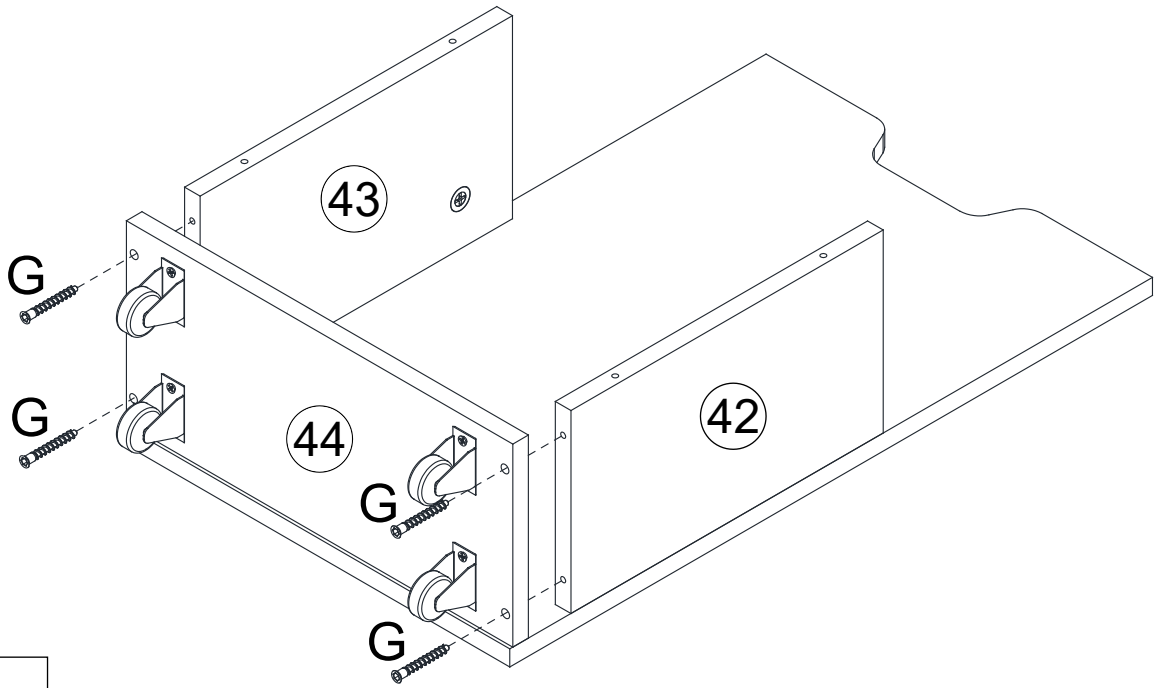

Gx8



M5X40

51X2

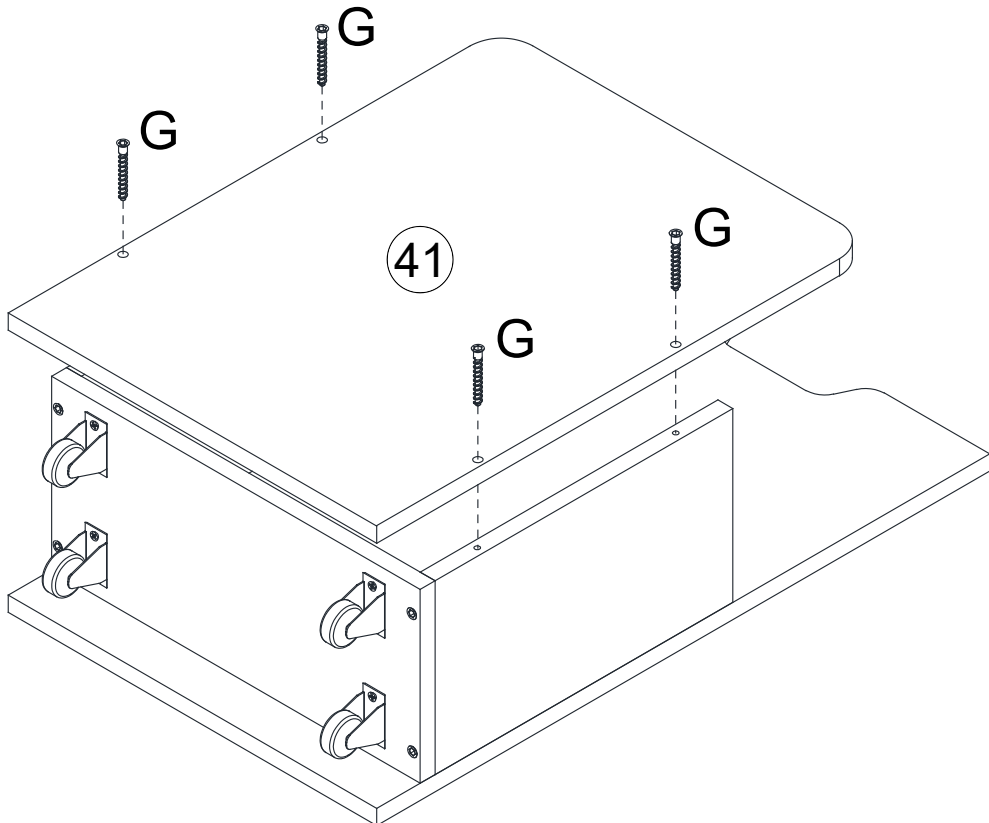

Gx8



M5X40

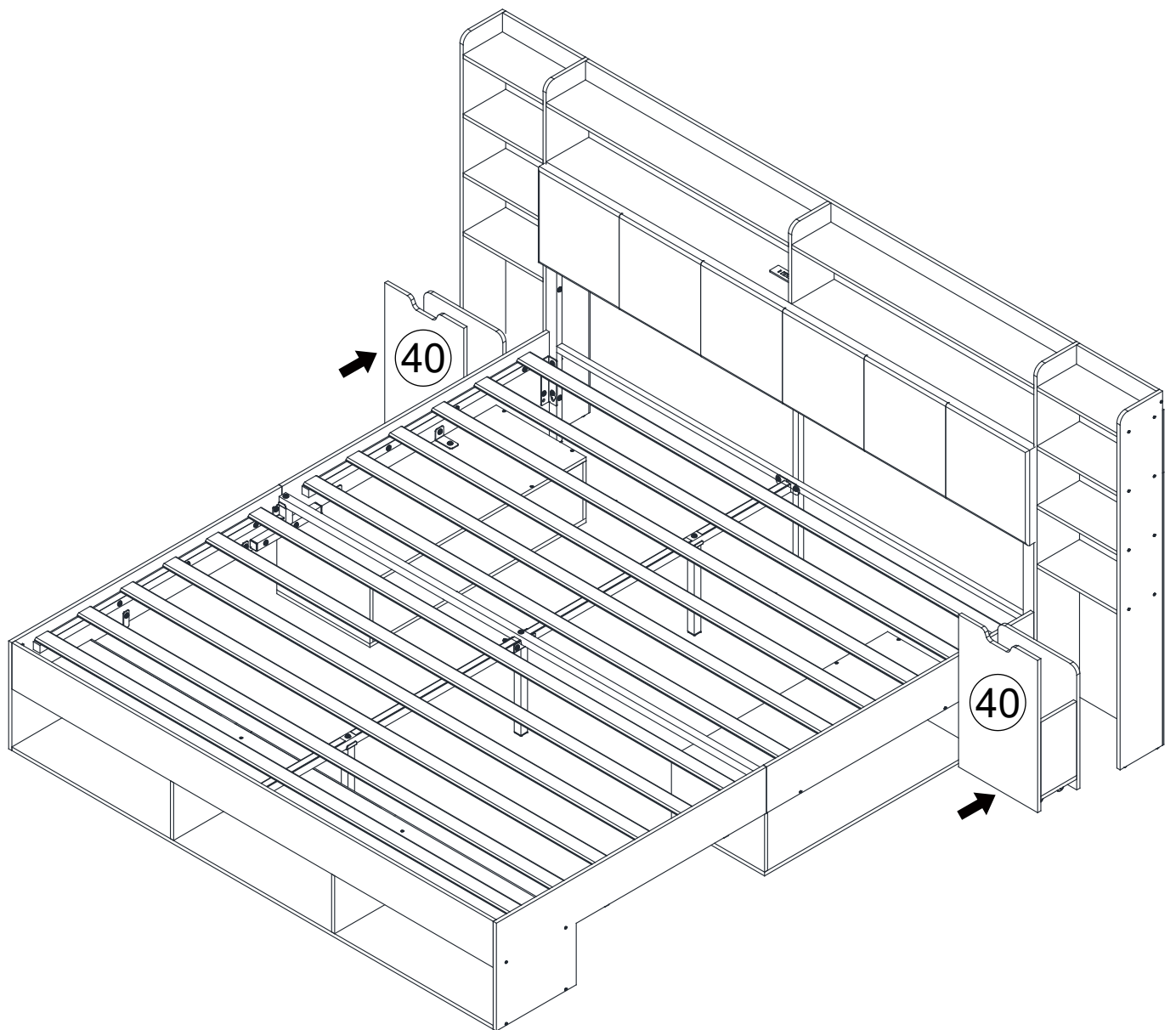

53X2

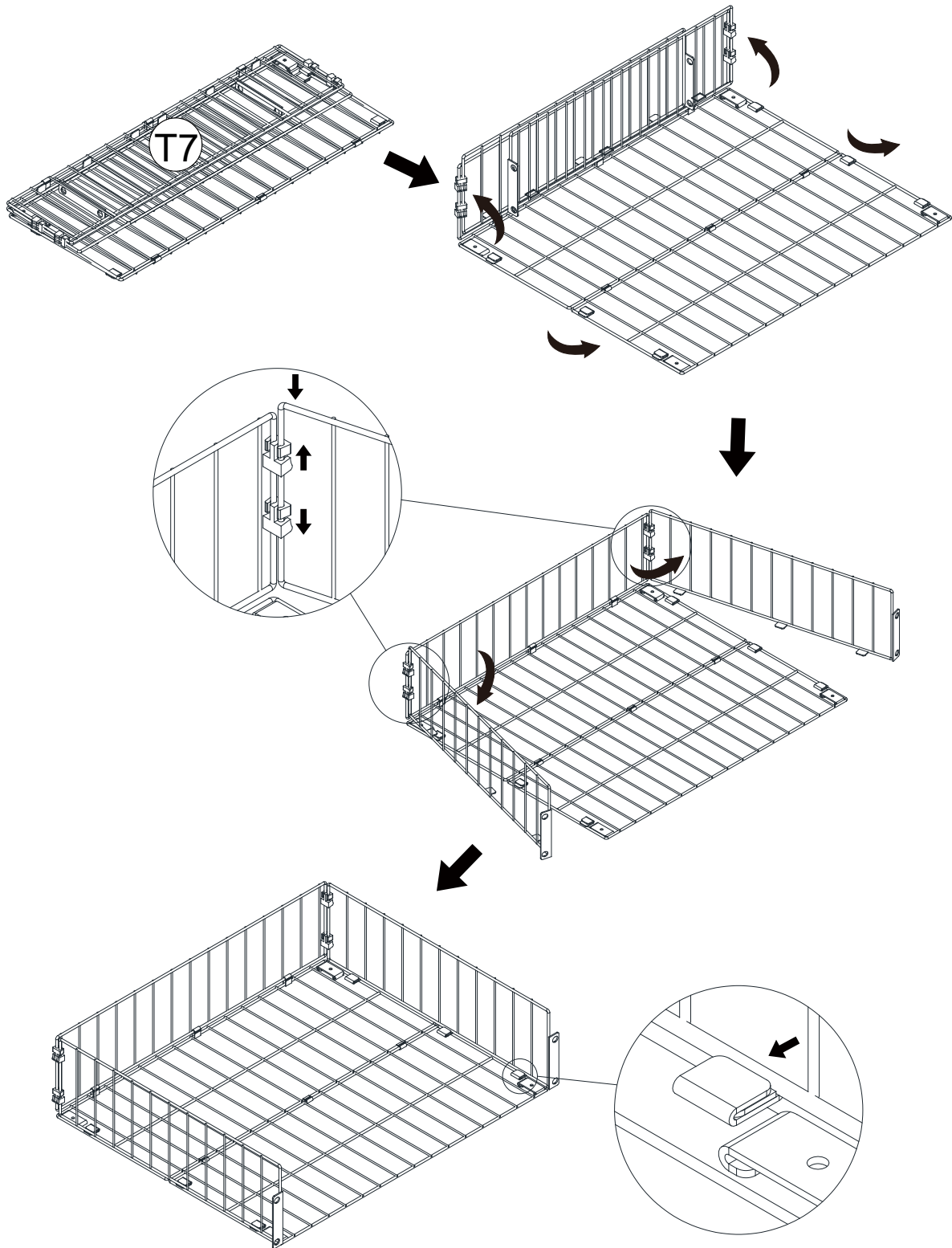

54X2

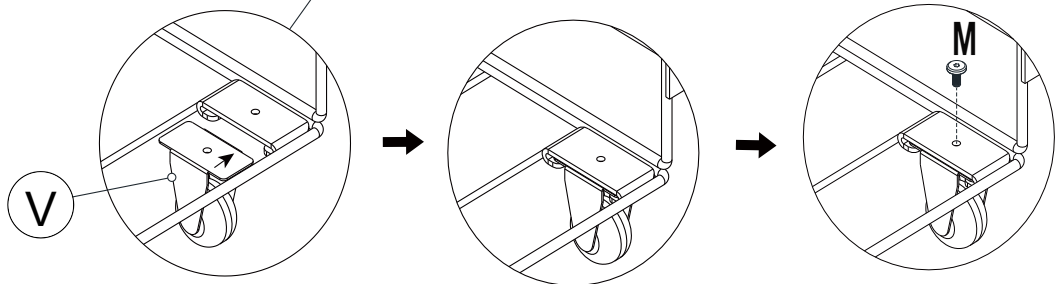
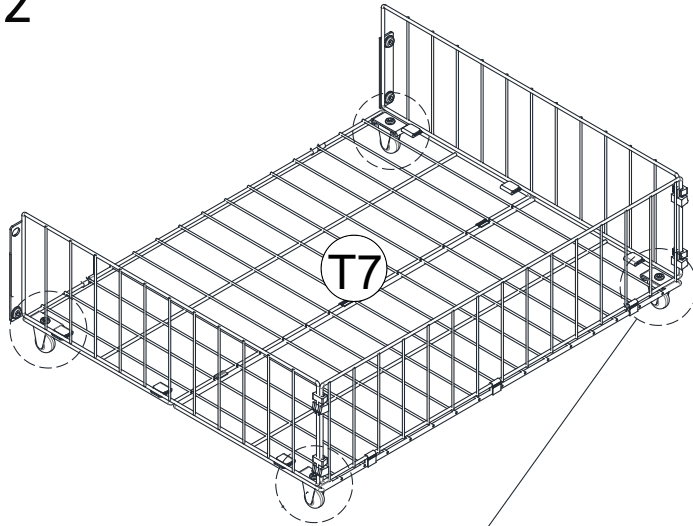

M x8



M4X10

55X2

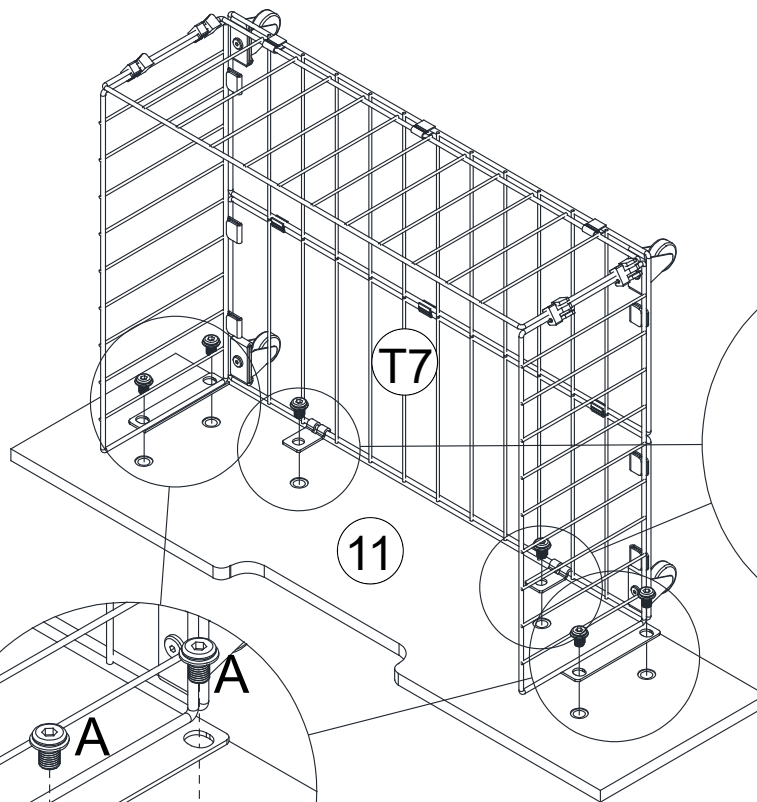

A x12



M8X12

N x4



GB: Tighten all hardware
DE: Ziehen Sie alle Beschläge fest
FR: Serrez toutes les ferrures
IT: Stringere tutta la ferramenta
ES: Apriete toda la tornillería

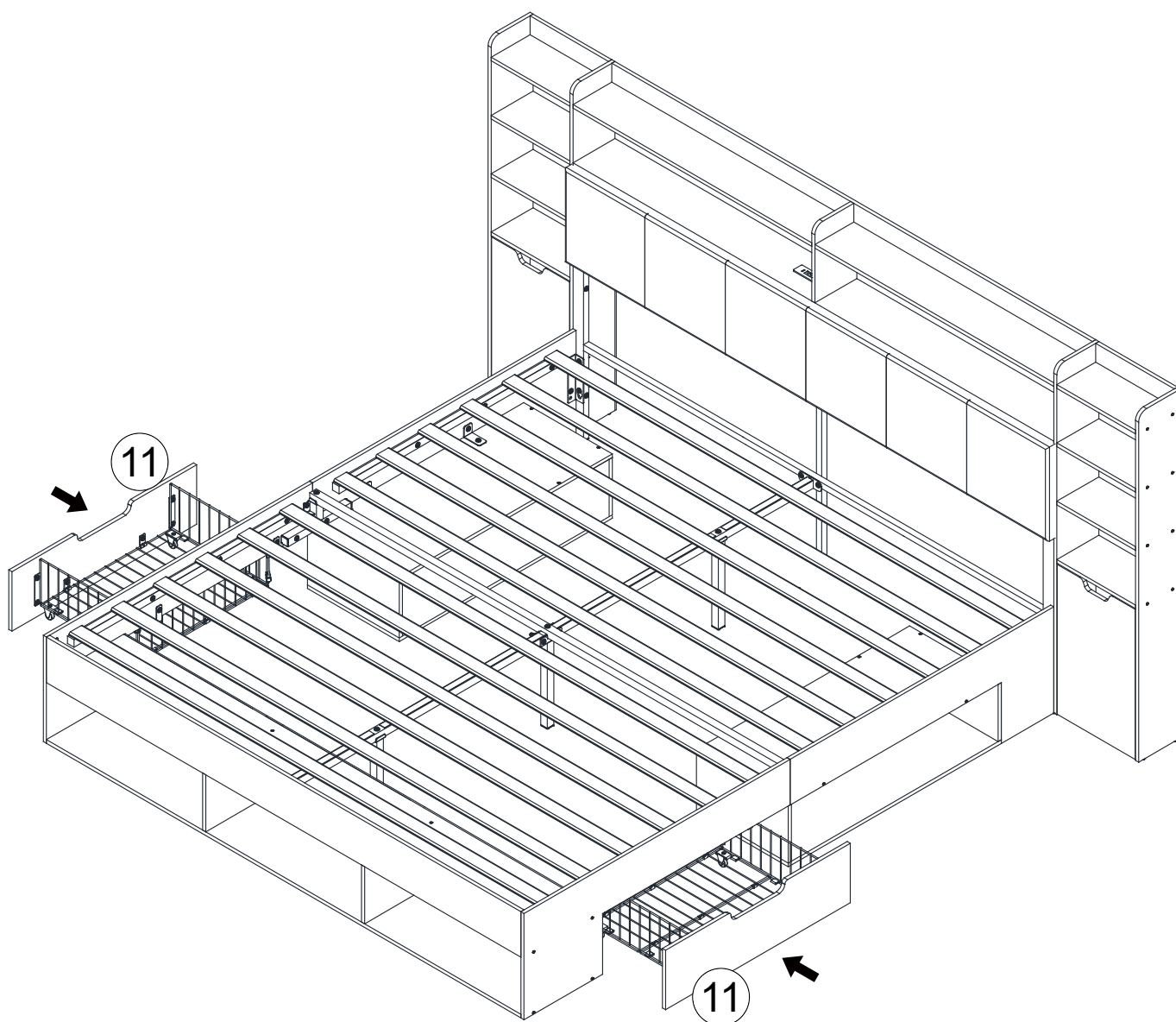

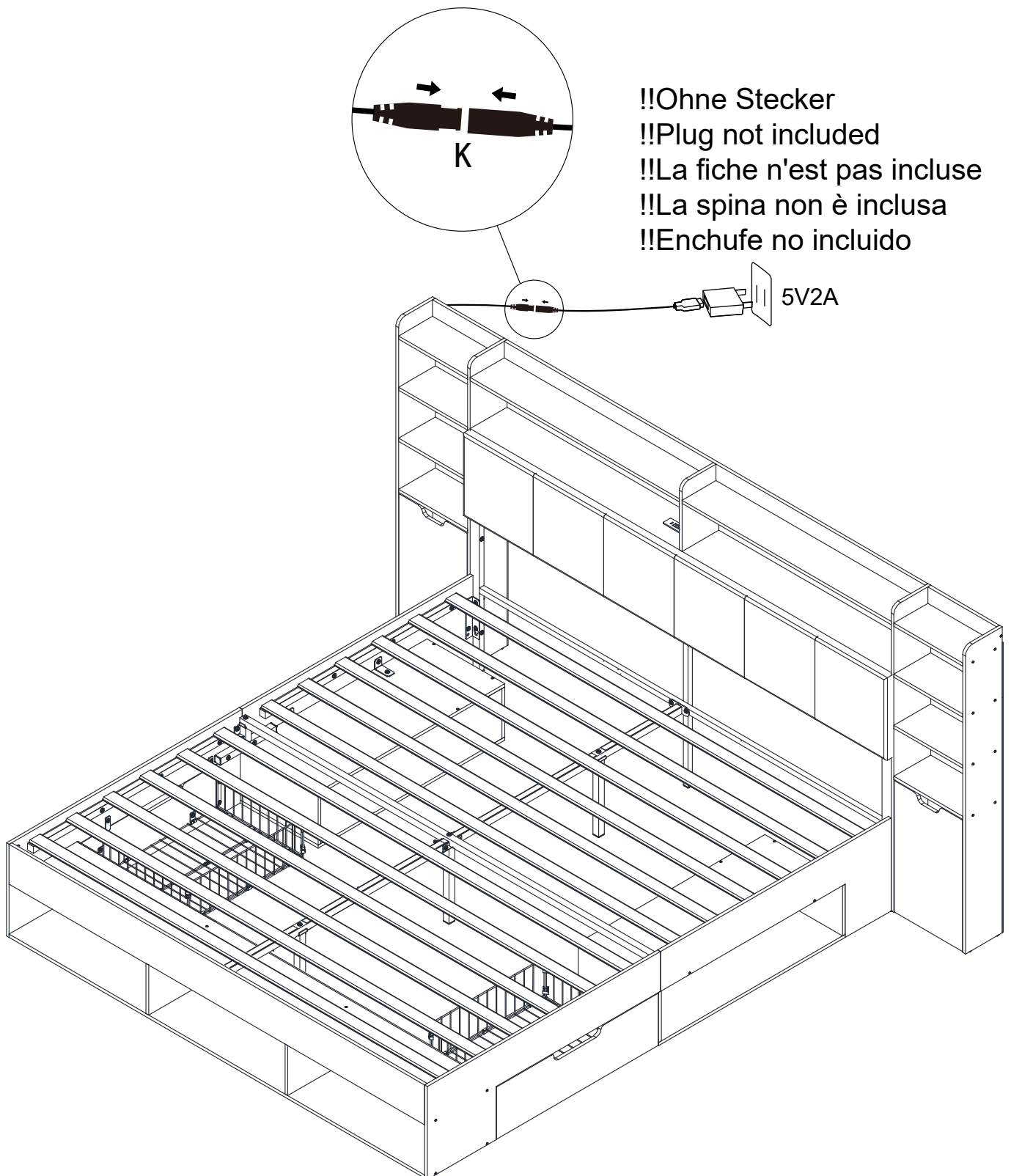

Installation Complete

GB – NOTE: The battery in the remote control requires you to purchase and install it yourself.
Model: CR2025 3.V

DE – HINWEIS: Die Batterie in der Fernbedienung müssen Sie selbst kaufen und installieren
Modell: CR2025 3.V

FR – REMARQUE : la pile de la télécommande doit être achetée et installée par vos soins.
Modèle : CR2025 3.V

IT – NOTA: la batteria del telecomando deve essere acquistata e installata autonomamente.
Modello: CR2025 3.V

ES – NOTA: La pila del mando a distancia debe comprarla e instalarla usted mismo
Modelo CR2025 3.V

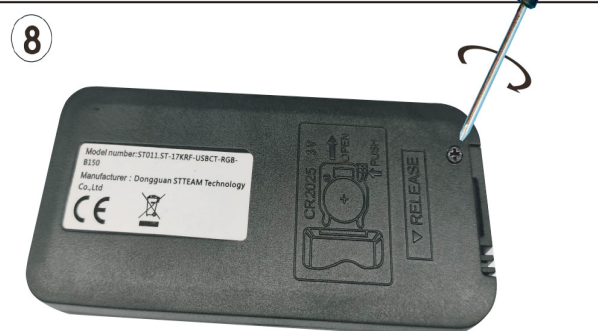

EN:Battery Safety Instructions

1. Do not dispose of used button batteries or remote controls in household trash. To protect the environment and prevent hazardous leakage, please follow these guidelines:
2. Remove button batteries after use and take them to a local battery recycling point or hazardous waste collection site.
3. Do not burn or dismantle the batteries to avoid explosion or toxic release.
4. If the remote control is no longer in use, please deliver it to a certified electronics recycling facility to promote resource reuse.
5. Keep out of reach of children to prevent accidental ingestion or injury.
6. This product does not include batteries; please purchase them separately. The compatible button cell model for the remote control is CR2025.3V
7. If the light strip is not working, please try replacing the battery first. If the issue persists, contact the seller for assistance.
8. **Keep the remote control away from children — keep it away from children!** If the battery is accidentally swallowed, seek medical attention immediately.

DE:Batteriesicherheitshinweise

1. Entsorgen Sie gebrauchte Knopfzellen oder Fernbedienungen nicht im Hausmüll. Um die Umwelt zu schützen und gefährliche Leckagen zu vermeiden, beachten Sie bitte die folgenden Hinweise:
2. Entfernen Sie die Knopfzelle nach dem Gebrauch und bringen Sie sie zu einer örtlichen Batteriesammelstelle oder einem Sondermüllentsorgungszentrum.
3. Batterien nicht verbrennen oder zerlegen, um Explosionen oder die Freisetzung giftiger Stoffe zu vermeiden.
4. Wenn die Fernbedienung nicht mehr verwendet wird, bringen Sie sie zu einer zertifizierten Elektronik-Recyclingstelle, um eine Wiederverwertung zu ermöglichen.
5. Außerhalb der Reichweite von Kindern aufbewahren, um versehentliches Verschlucken oder Verletzungen zu verhindern.
6. Dieses Produkt enthält keine Batterien. Bitte kaufen Sie diese separat. Das kompatible Knopfzellenmodell für die Fernbedienung ist CR2025.3V
7. Wenn der Lichtstreifen nicht funktioniert, versuchen Sie zunächst, die Batterie zu wechseln. Besteht das Problem weiterhin, kontaktieren Sie bitte den Verkäufer.
8. **Halten Sie die Fernbedienung unbedingt von Kindern fern — unbedingt fernhalten!** Wird die Batterie versehentlich verschluckt, suchen Sie sofort medizinische Hilfe auf.

FR:Instructions de sécurité pour les piles

1. Ne jetez pas les piles bouton usagées ou les télécommandes à la poubelle ménagère. Pour protéger l' environnement et éviter tout risque de fuite dangereuse, veuillez suivre les consignes suivantes :
 2. Retirez les piles bouton après usage et déposez-les dans un point de collecte local ou un centre de déchets dangereux.
 3. Ne brûlez pas et ne démontez pas les piles, cela pourrait entraîner une explosion ou libérer des substances toxiques.
 4. Si la télécommande n'est plus utilisée, déposez-la dans un centre de recyclage agréé pour appareils électroniques, afin de favoriser la réutilisation des ressources.
 5. Gardez hors de portée des enfants pour éviter tout risque d'ingestion accidentelle ou de blessure.
- 6.Ce produit ne contient pas de pile. Veuillez l'acheter séparément. Le modèle de pile bouton compatible pour la télécommande est CR2025.3V
- 7.Si le ruban LED ne fonctionne pas, essayez d'abord de remplacer la pile. Si le problème persiste, contactez le vendeur.
- 8.**Tenez la télécommande éloignée des enfants — éloignez-la vraiment !** En cas d'ingestion accidentelle de la pile, consultez immédiatement un médecin.



CERTIFICATE OF CONFORMITY

Certificate No. FCS202503546CA01

Product British socket

Brand Name Using

Model(s) No. YS-8033

Series Model YS-8034, YS-8035, YS-8036, YS-8037, YS-8038, YS-8039, YS-135801, YS-135802, YS-135803, YS-135804, YS-135805

Holder Shenzhen Using Intelligent Technology CO.,LTD.

Address A1605, Excellence Meilin Center Square (South District), No. 126 Zhongkang Road, Meidu Community, Meilin Street, Futian District, Shenzhen

Manufacturer Shenzhen Using Intelligent Technology Co., Ltd. Dongguan Branch

Address 5th Floor, Building 2, No. 55 West Road, Shilong Section, Dongjiang Avenue, Shilong Town, Dongguan City, Guangdong Province

Report No. FCS202503546E02



TEST STANDARDS:

EN 55032:2015/A1:2020

EN 55035:2017/A11:2020

EN 61000-4-2:2009 EN IEC 61000-4-3:2020

EN 61000-4-4:2012 EN 61000-4-5:2014/A1:2017

EN 61000-4-6:2013 EN 61000-4-8:2010

EN 61000-4-11:2004/A1:2017

The applicant of the certificate is authorized to use this certificate in connection with EC declaration of conformity to the Directive. The certificate is only applicable to the equipments described above.

The submitted sample of the above equipment has been tested and found to comply with the following European Directive

EMC Directive - 2014/30/EU



Approved by: *Jack Wang*

March 28, 2025

Jack Wang/Managerial



The statement is based on a single evaluation of the sample of above mentioned product(s). It does not imply an assessment of the whole production.

Dongguan Funas Testing Technology Co.,Ltd.

Add: Room 105 Floor Bao hao Technology Building 1 NO.15 Gong ye West Road Hi-TechIndustrial, Song shan lake Dongguan, China

Tel: 0769-27280901 Fax:0769-27280901 <http://www.fcs-lab.com>

E-mail:andy.yue@fcs-lab.com

Certificate No. FCS202503546CA02

Product British socket

Brand Name Using

Model(s) No. YS-8033

Series Model YS-8034, YS-8035, YS-8036, YS-8037, YS-8038, YS-8039, YS-135801, YS-135802, YS-135803, YS-135804, YS-135805

Holder Shenzhen Using Intelligent Technology CO.,LTD.

Address A1605, Excellence Meilin Center Square (South District), No. 126 Zhongkang Road, Meidu Community, Meilin Street, Futian District, Shenzhen

Manufacturer Shenzhen Using Intelligent Technology Co., Ltd. Dongguan Branch

Address 5th Floor, Building 2, No. 55 West Road, Shilong Section, Dongjiang Avenue, Shilong Town, Dongguan City, Guangdong Province

Report No. FCS202503546A01



TEST STANDARDS:

EN IEC 62368-1:2024 + A11:2024

The applicant of the certificate is authorized to use this certificate in connection with EC declaration of conformity to the Directive. The certificate is only applicable to the equipments described above.

The submitted sample of the above equipment has been tested and found to comply with the following European Directive

LVD Directive - 2014/35/EU Directive



Approved by: *Jack Wang*

March 28, 2025

Jack Wang/Managerial



The statement is based on a single evaluation of the sample of above mentioned product(s). It does not imply an assessment of the whole production.

Dongguan Funas Testing Technology Co.,Ltd.

Add: Room 105 Floor Bao hao Technology Building 1 NO.15 Gong ye West Road Hi-TechIndustrial, Song shan lake Dongguan, China

Tel: 0769-27280901 Fax:0769-27280901 <http://www.fcs-lab.com>

E-mail:andy.yue@fcs-lab.com



CERTIFICATE OF COMPLIANCE

Directives: 2014/53/EU

Certification number: CTE241230009

Issued date: Jan. 08, 2025

Applicant: Dongguan STTEAM Technology Co.,Ltd
No.605, Diwang Square, Chang'an Town, Dongguan City, China

Manufacturer: Dongguan STTEAM Technology Co.,Ltd
No.605, Diwang Square, Chang'an Town, Dongguan City, China

EUT Name: RF Remote Control Kit

Trade Mark: N/A

Model number: ST402, ST403

Laboratory: Shenzhen CTA Testing Technology Co., Ltd.
Room 106, Building 1, Yibaolai Industrial Park, Qiaotou Community, Fuhai Street,
Bao'an District, Shenzhen, China

In accordance with the following Applicable Directives: 2014/53/EU RED DIRECTIVE

The equipment, as described herewith, was tested pursuant to applicable test procedure and complies with the requirements of:

Requirement	Applied Standards	Test Report No.	Result
Radio	ETSI EN 300 220-1 V3.1.1 (2017-02) ETSI EN 300 220-2 V3.2.1 (2018-06)	CTA24123000901	Conform
EMC	ETSI EN 301 489-1 V2.2.3 (2019-11) ETSI EN 301 489-3 V2.3.2 (2023-01) EN 55032:2015+A11:2020/EN 55035:2017+A11:2020 EN IEC 61000-3-2:2019/A2:2024 EN 61000-3-3:2013/A2:2021/AC:2022	CTA24123000902	Conform
Health	EN50663:2017/EN62479:2010	CTA24123000903	Conform
Safety	EN IEC 62368-1:2020+A11:2020	CTA24123000904	Conform

The test results are traceable to the international or national standards.

Note:



The verification is only valid for the equipment and configuration described, in conjunction with the test data detailed above. The CE mark as shown beside can be used under the responsibility of the manufacturer, after completion of an EC Directive of Conformity and compliance with all relevant EC Directive.

Authorized by:

Eric Wang



Shenzhen CTA Testing Technology Co., Ltd.

Room 106, Building 1, Yibaolai Industrial Park, Qiaotou Community, Fuhai Street, Bao'an District, Shenzhen, China

Tel: +86-755 2322 5875

E-mail: cta@cta-test.cn

Web: http://www.cta-test.cn

Certificate of Conformity

RoHS Directive 2011/65/EU

Of the European Parliament and of the council
on the Restriction of the use of certain Hazardous
Substances in Electrical and Electronic equipment

Issue Date: December 31, 2025

Applicant : Dongguan STTEAM Technology Co.,Ltd
Address : No.605, Diwang Square, Chang'an Town, Dongguan City,China
Sample Name : Remote control aluminum tube light kit, LED light strip set, USB A+C
Charger
Item No. : ST700, ST700A, ST700B, ST700C, ST700D, ST700E, ST700F, ST700G,
ST700H, ST700I, ST700J, ST700K, ST402, ST403, ST401, ST400,
ST200, ST201, ST201A, ST201B, ST201C, ST201D, ST201E, ST201F,
ST201G, ST201H, ST301, ST302, ST501, ST501A, ST501B, ST501C,
ST501D, ST501E, ST501F, ST501G, ST501H, ST501I, ST302A, ST302B,
ST302C, ST302D, ST302E, ST302F, ST302G, ST302H, ST302I, ST302J,
ST302K
Manufacturer : Dongguan STTEAM Technology Co.,Ltd
Address : No.605, Diwang Square, Chang'an Town, Dongguan City,China

This certificate of compliance is based on a test procedure or an evaluation of the above-mentioned product. This is to certify that the above-mentioned product is in compliance with the RoHS2.0 Directive (2011/65/EU) of the European Parliament and Amendments Commission Delegated Directive (EU) 2015/863. It is only valid in connection with the test report (Report No.: SFT251225103977E).

RoHS 2.0

GuangDong Safety Testing Co., Ltd.

No.1, the 1st North Industry Road, Songshan Lake Sci.&Tech. Park, Dongguan, Guangdong, China

Tel:86-769-23105888

Fax: 86-769-22899858

<http://www.sft-cert.com/>

CERTIFICATE OF CONFORMITY

Certificate No.: KEYS241104015001RH-03R1

Applicant : SHENZHEN Using Intelligent Technology CO.,LTD.
Address : No. 22 Chenwu Road, Dakang Community, Yuanshan Street, Longgang District, Shenzhen
Manufacturer : Shenzhen Yousheng Intelligent Technology Co., Ltd. Dongguan Branch
Address : Room 504, Building 2, No. 55 West Shilong Section, Dongjiang Avenue, Shilong Town, Dongguan City, Guangdong Province
Sample Name : British socket
Trademark : Using
Main Model : YS-UK1660
Additional model : YS-UK1661,YS-UK1662,YS-UK1663,YS-UK1664,YS-UK1665,
IYS-MUI661,YS-MUI662,YS-MUI663,YS-MUI664,YS-MUI665,
YS-EU1661,YS-EU1662,YS-EU1663,YS-EU1664,YS-EU1665,YS-8033

RoHS 2.0 Directive (EU) 2015/863 and (EU)2017/2102 amending Annex II to Directive 2011/65/EU.
The standard(s) used for showing compliance with the essential requirements:

Applicable Standard(s) IEC 62321-3-1: 2013
IEC 62321-4: 2013 +AMD1:2017
IEC 62321-5: 2013
IEC 62321-6: 2015
IEC 62321-7-1: 2015
IEC 62321-7-2: 2017
IEC 62321-8: 2017

The EUT described above has been consolidated by us and found in compliance with the council RoHS 2.0 Directive (EU) 2015/863 and (EU)2017/2102 amending Annex II to Directive 2011/65/EU.
The certificate applies to the tested sample above mentioned only and shall not imply an assessment of the whole production. It is only valid in connection with the test report number. KEYS241104015001RH-03R1

RoHS



Tony Qian/Approved Signatory
Date: Nov.06, 2024



Scan to view
the original file

Guangdong KEYS Testing Technology Co., Ltd.

Address: Building 1, No.18, Shihuan Road, Dongcheng Subdistrict, Dongguan, Guangdong, China
Tel: +86-0769-89798319 <http://www.keys-lab.com> E-mail: info@keys-lab.com