

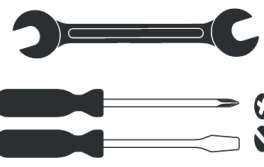

**Vente-unique**.com  
Du bonheur à tous les étages

# ALANE

200 x 160/180/200 cm



#13

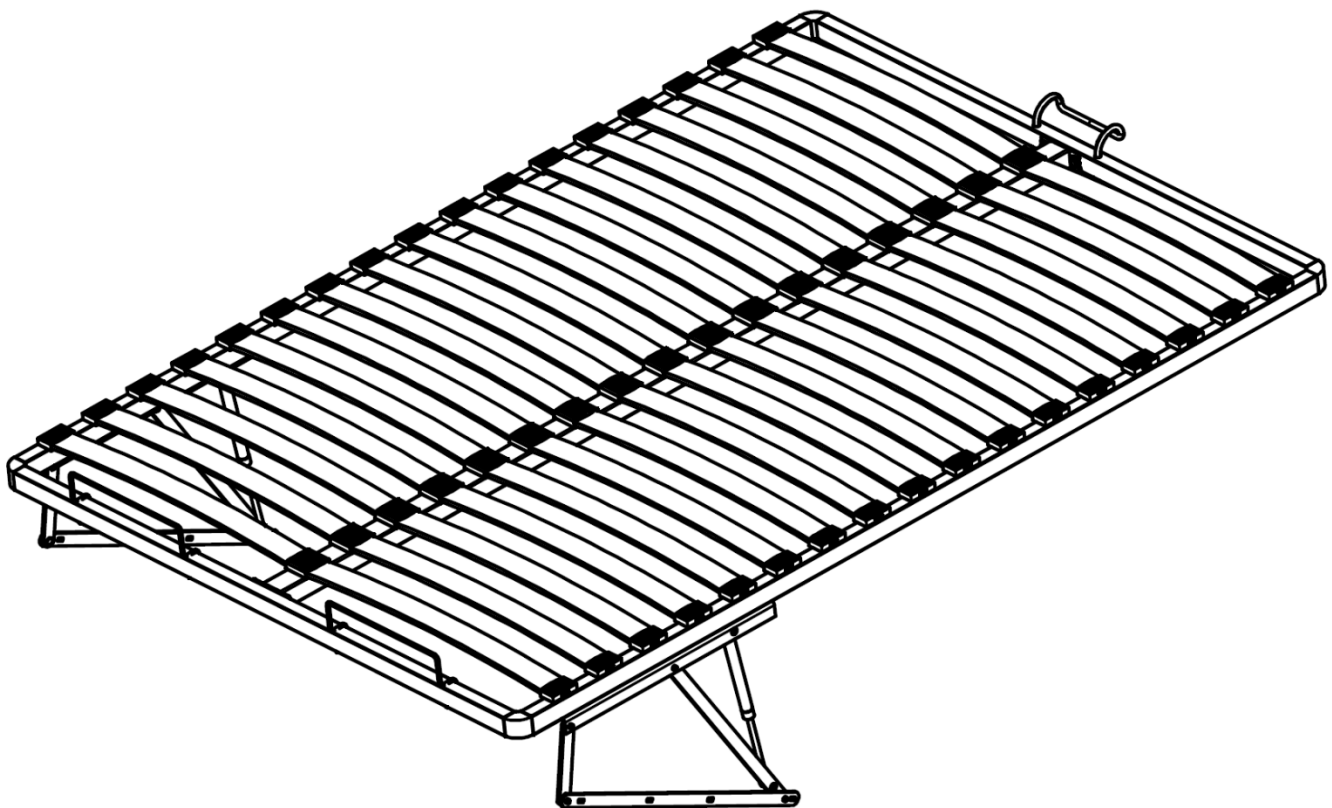

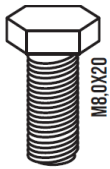
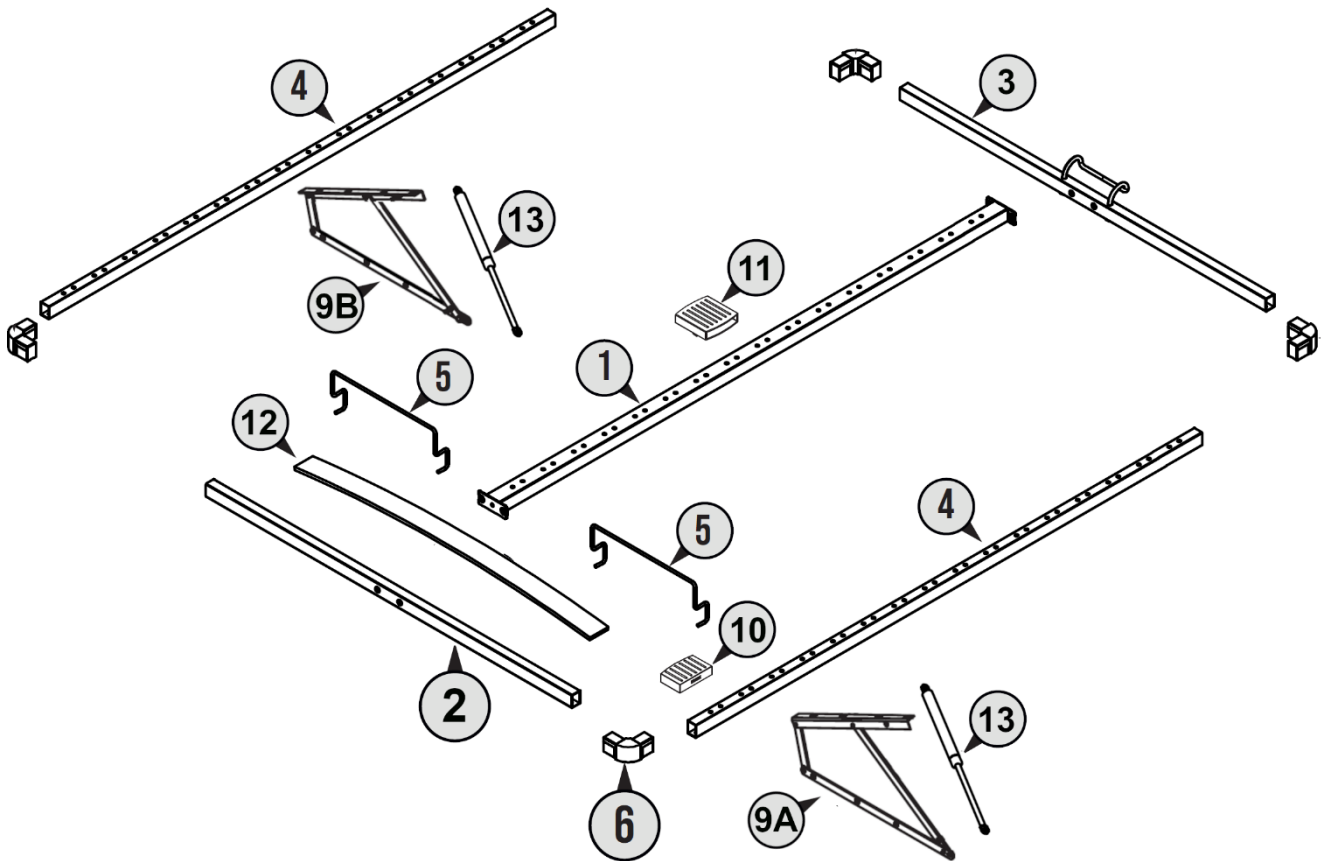

7



8



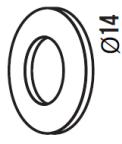

14

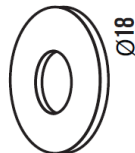

15



16

#		
1	1	1
2	1	1
3	1	1
4	1	2
5	1	2
6	1	4
7	1	12
8	1	8
9A	1	1
9B	1	1
10	1	34
11	1	17
12	1	34
13	1	2
14	1	4
15	1	8
16	1	8

# INSTRUCTIONS DE SÉCURITÉ ET D'UTILISATION DU LIT

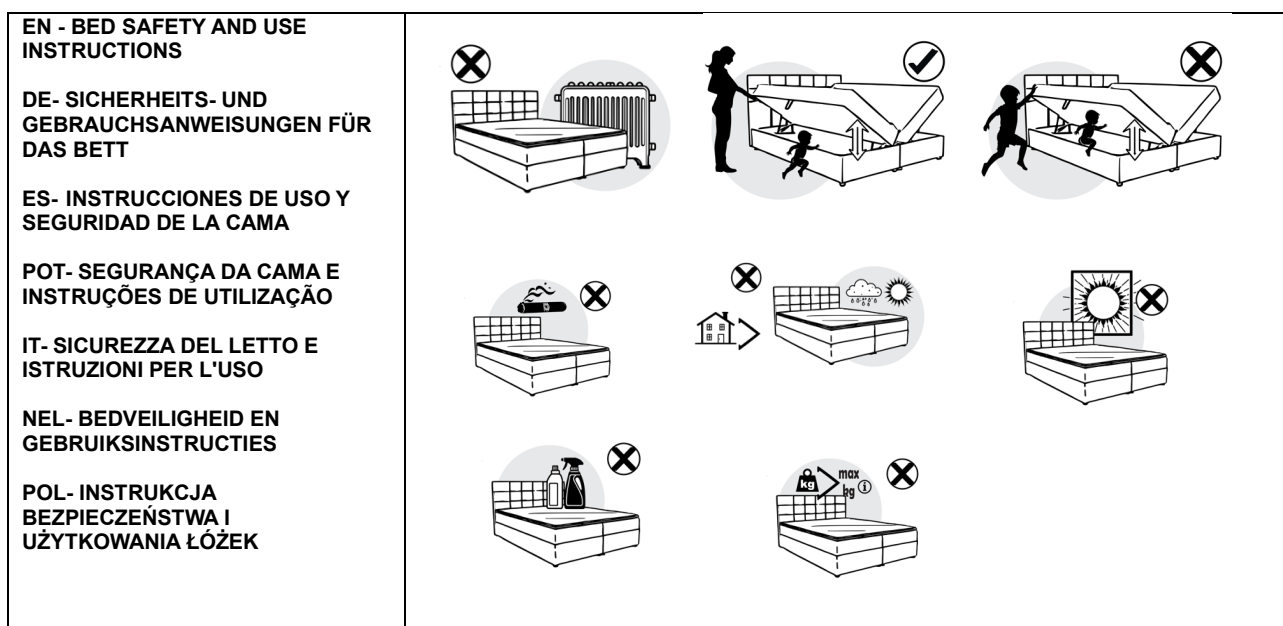

La surface doit être nettoyée avec un chiffon humide ou avec des détergents dédiés. Les déversements doivent être éliminés immédiatement avec un tampon propre et sec pour absorber le liquide. Ne frottez pas, cela pourrait endommager le tissu. Des variations de couleur entre les surfaces nettoyées et non nettoyées peuvent apparaître. En cas de doute, contactez un professionnel pour effectuer le nettoyage.

Surface shall be cleaned with moist cloth or with dedicated detergents. Spills should be removed immediately with a clean and dry dabbing to absorb the liquid. Do not rub, it may damage the fabric. Variations in color between the surfaces cleaned and uncleaned might appear. If in doubt, contact a professional to carry out cleaning.

Die Oberfläche muss mit einem feuchten Tuch oder speziellen Reinigungsmitteln gereinigt werden. Verschüttete Flüssigkeiten sollten sofort mit einem sauberen und trockenen Tupfer entfernt werden, um die Flüssigkeit aufzusaugen. Nicht reiben, da dies den Stoff beschädigen könnte. Es kann zu Farbabweichungen zwischen gereinigter und ungereinigter Oberfläche kommen. Wenden Sie sich im Zweifelsfall an einen Fachmann, um die Reinigung durchführen zu lassen.

La superficie se limpiará con un paño húmedo o con detergentes específicos. Los derrames deben eliminarse inmediatamente con un paño limpio y seco para absorber el líquido. No frotar, puede dañar la tela. Pueden aparecer variaciones de color entre las superficies limpiadas y sin limpiar. En caso de duda contacta con un profesional para realizar la limpieza.

A superfície deve ser limpa com pano úmido ou com detergentes específicos. Os derramamentos devem ser removidos imediatamente com um pano limpo e seco para absorver o líquido. Não esfregue, pode danificar o tecido. Podem aparecer variações de cor entre as superfícies limpas e não limpas. Em caso de dúvida, procure um profissional para realizar a limpeza.

La superficie dovrà essere pulita con un panno umido o con detergenti dedicati. Le fuoriuscite devono essere rimosse immediatamente con un panno pulito e asciutto per assorbire il liquido. Non strofinare, potrebbe danneggiare il tessuto. Potrebbero apparire variazioni di colore tra le superfici pulite e quelle non pulite. In caso di dubbi, rivolgersi ad un professionista per effettuare la pulizia.

Het oppervlak moet worden gereinigd met een vochtige doek of met speciale reinigingsmiddelen. Gemorste vloeistoffen moeten onmiddellijk worden verwijderd door schoon en droog te deppen om de vloeistof te absorberen. Niet wrijven, dit kan de stof beschadigen. Er kunnen kleurvariaties optreden tussen de gereinigde en ongereinigde oppervlakken. Neem bij twijfel contact op met een professional om de reiniging uit te voeren.

Powierzchnię należy czyścić wilgotną szmatką lub specjalnymi detergentami. Rozlane ciecze należy natychmiast usunąć czystym i suchym przetrarciem, aby wchłonąć płyn. Nie trzyj, może to spowodować uszkodzenie tkaniny. Mogą pojawić się różnice w kolorze pomiędzy powierzchniami oczyszczonymi i nieoczyszczonymi. W razie wątpliwości należy skontaktować się ze specjalistą w celu przeprowadzenia czyszczenia

# 1

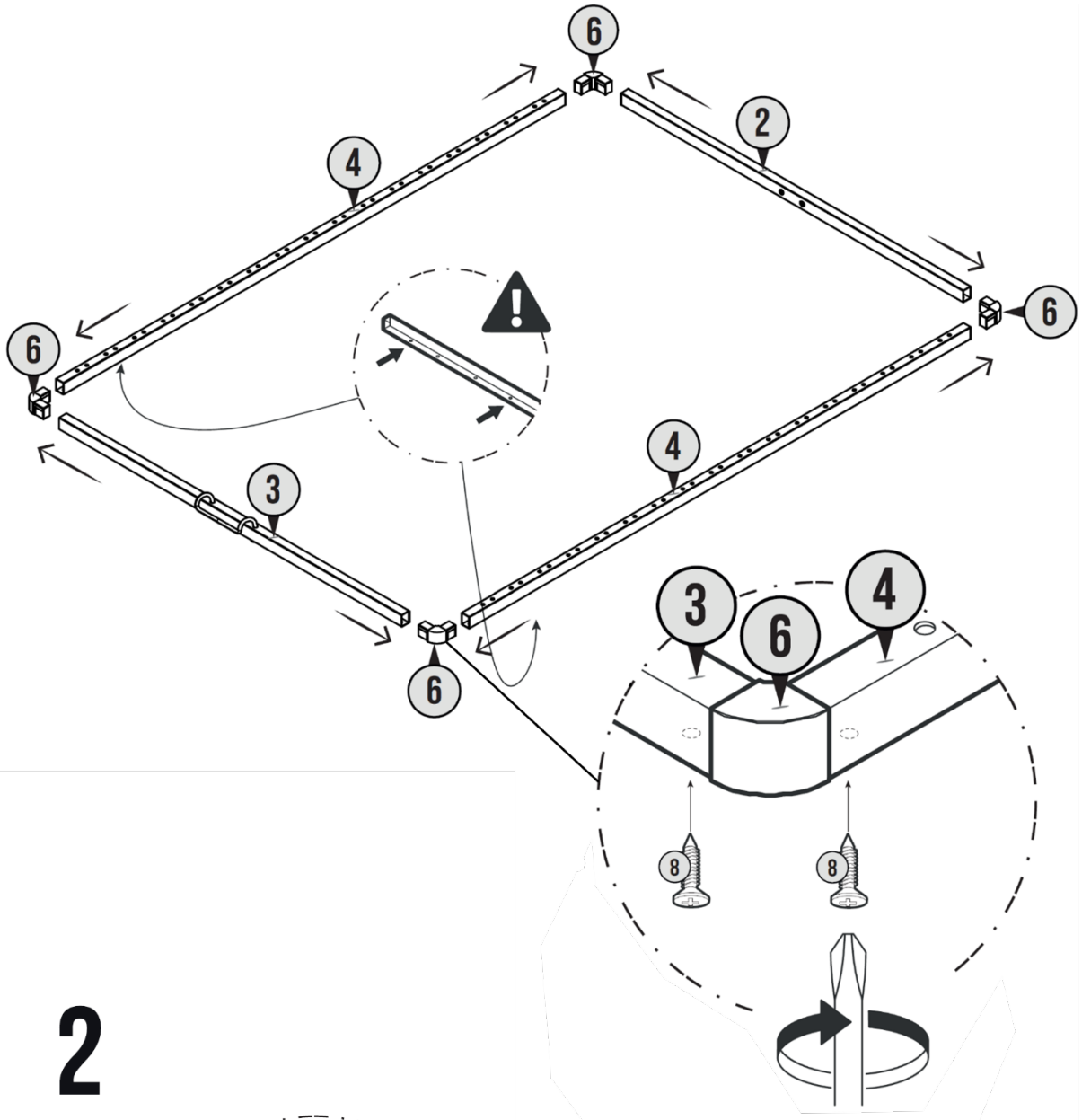

# 2

## 17X

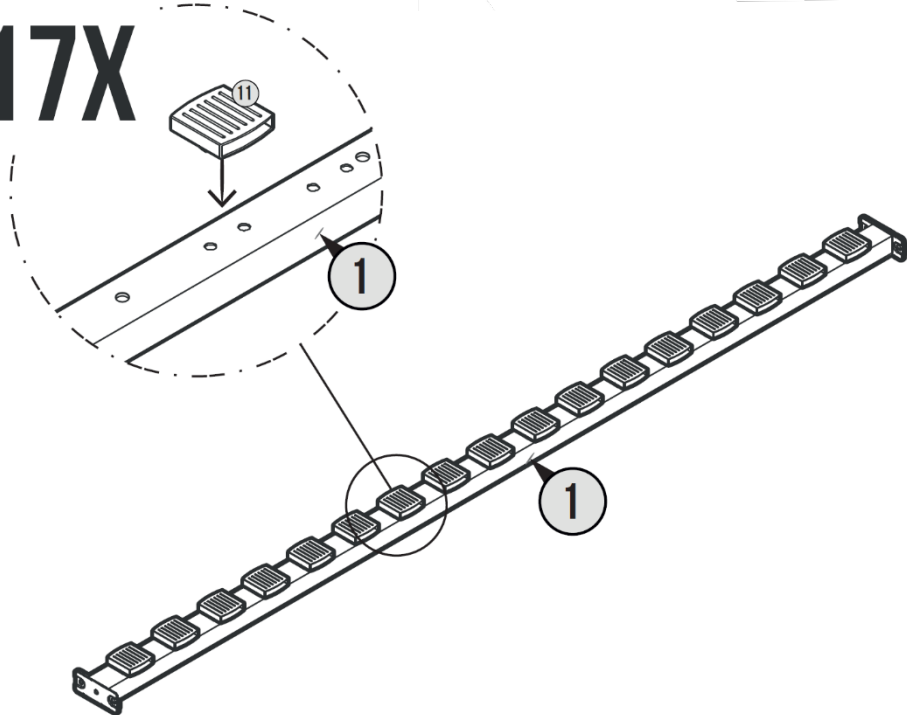

3

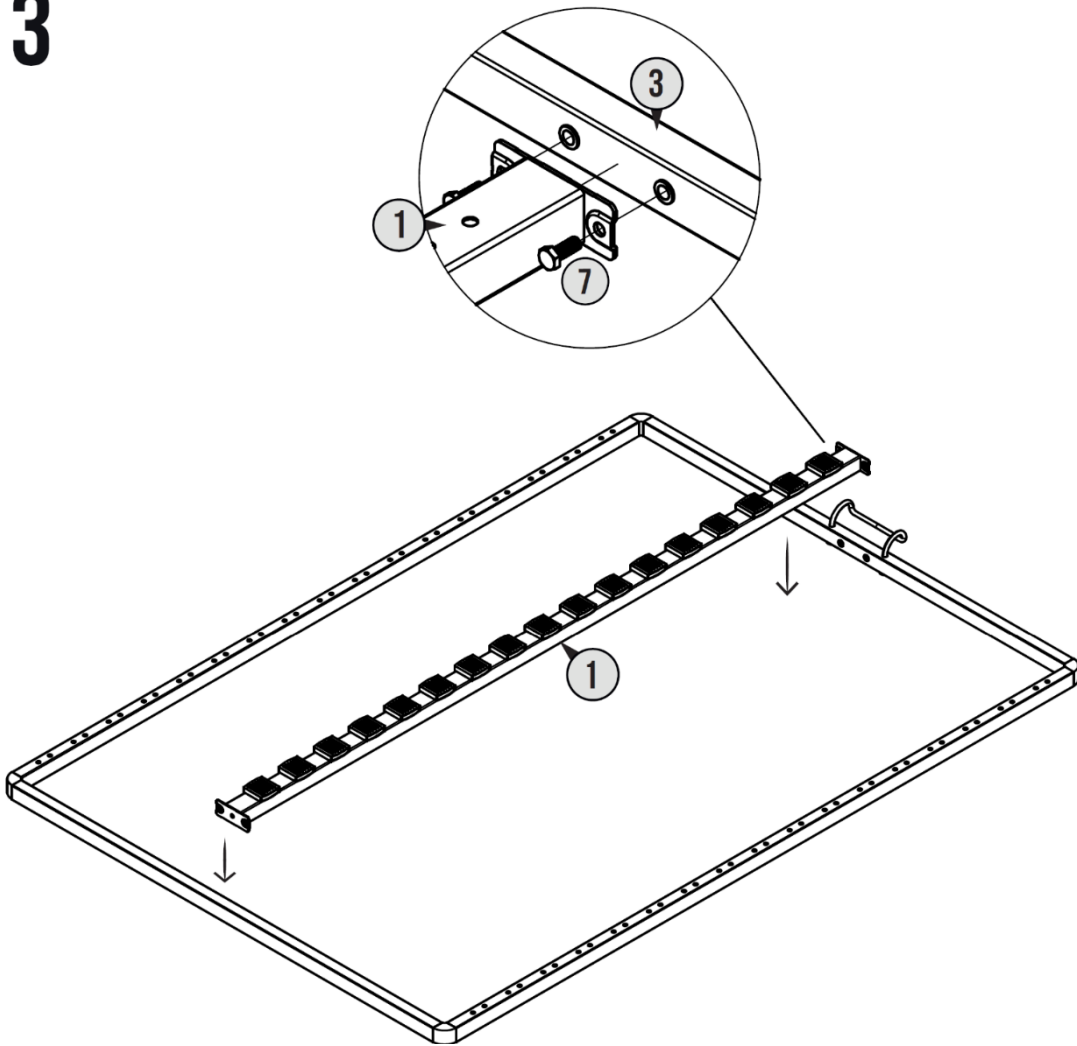

4

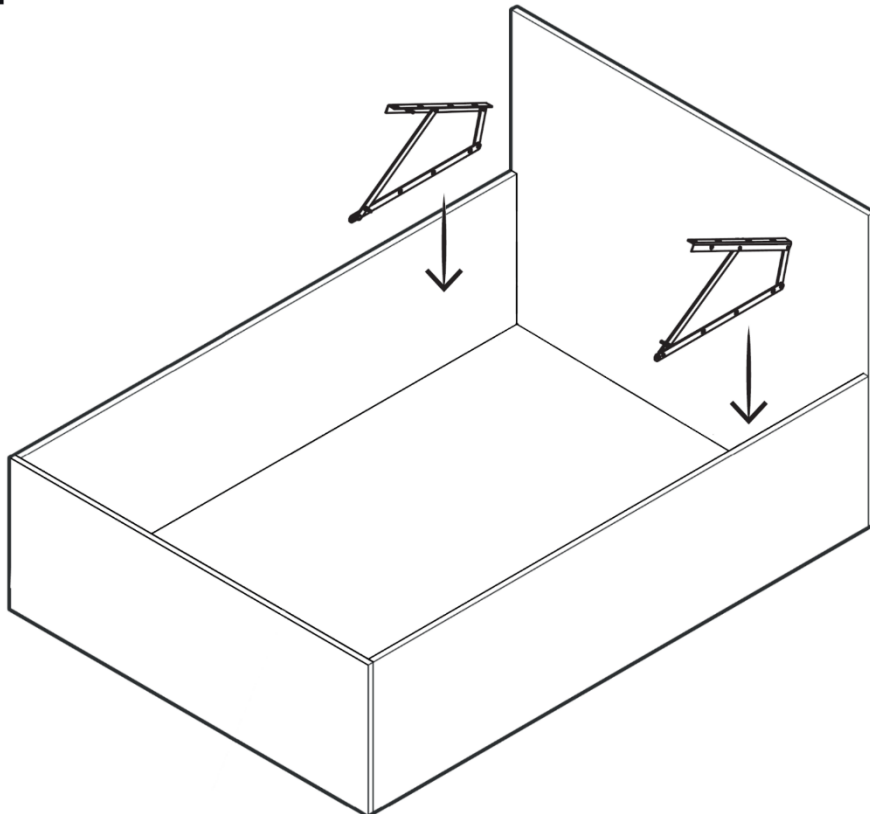

5

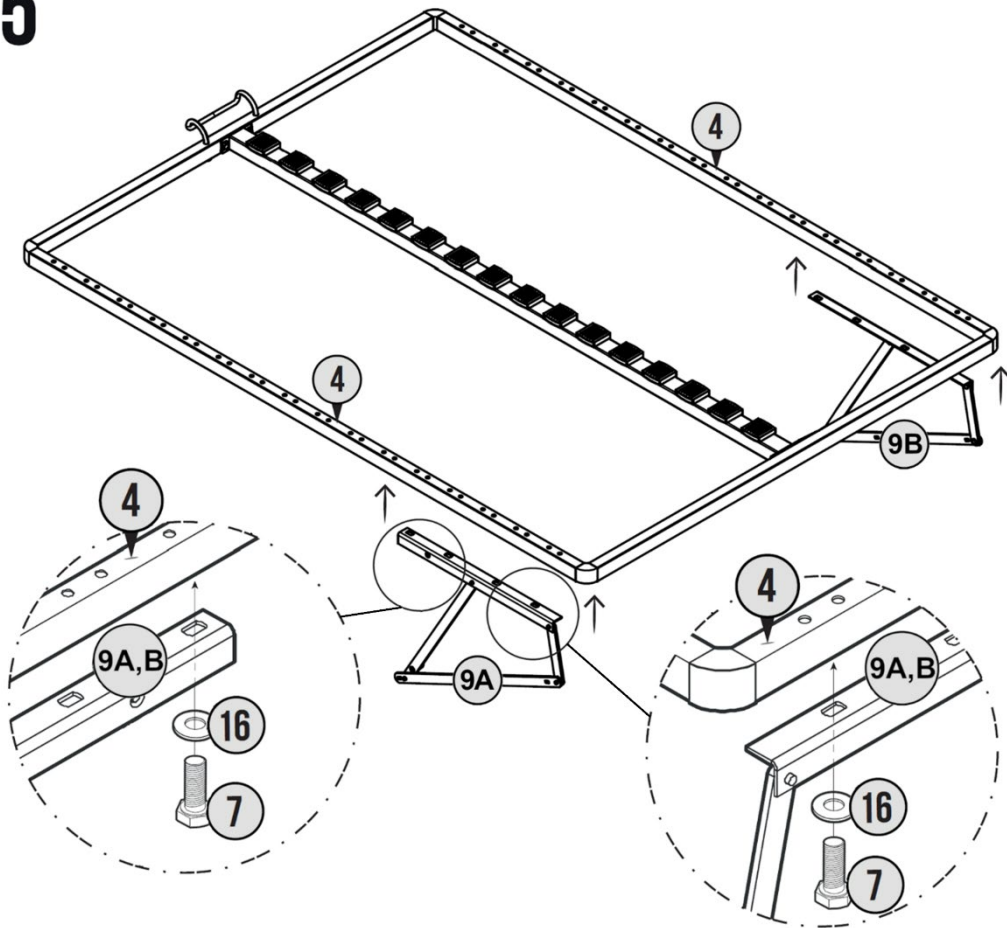

6

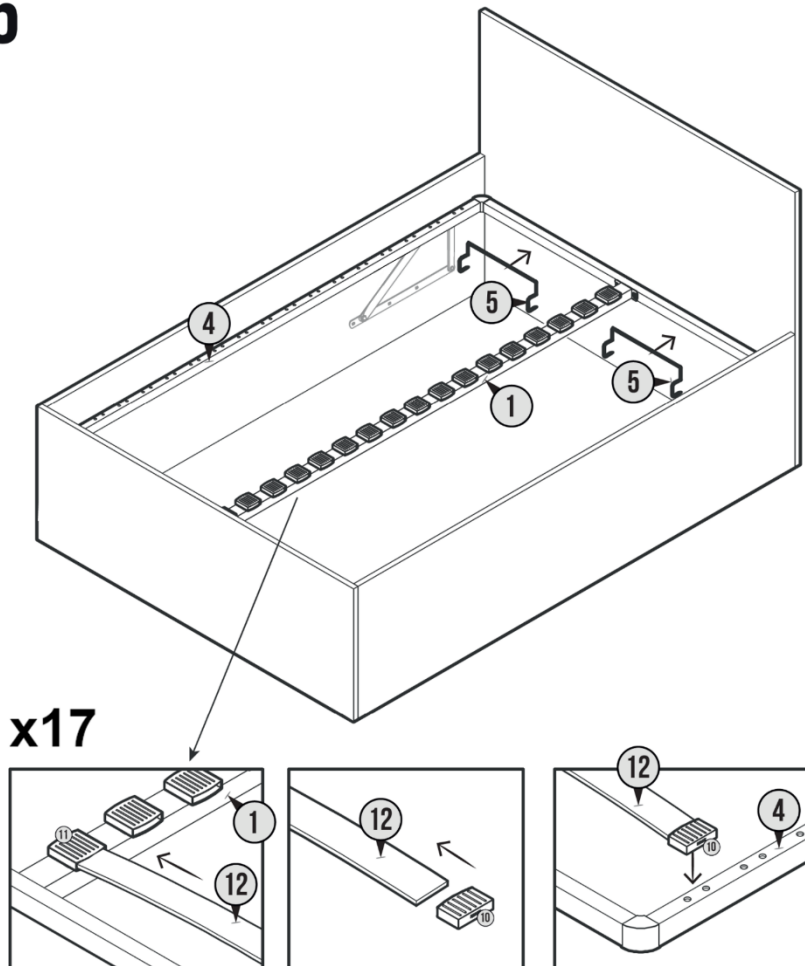

7

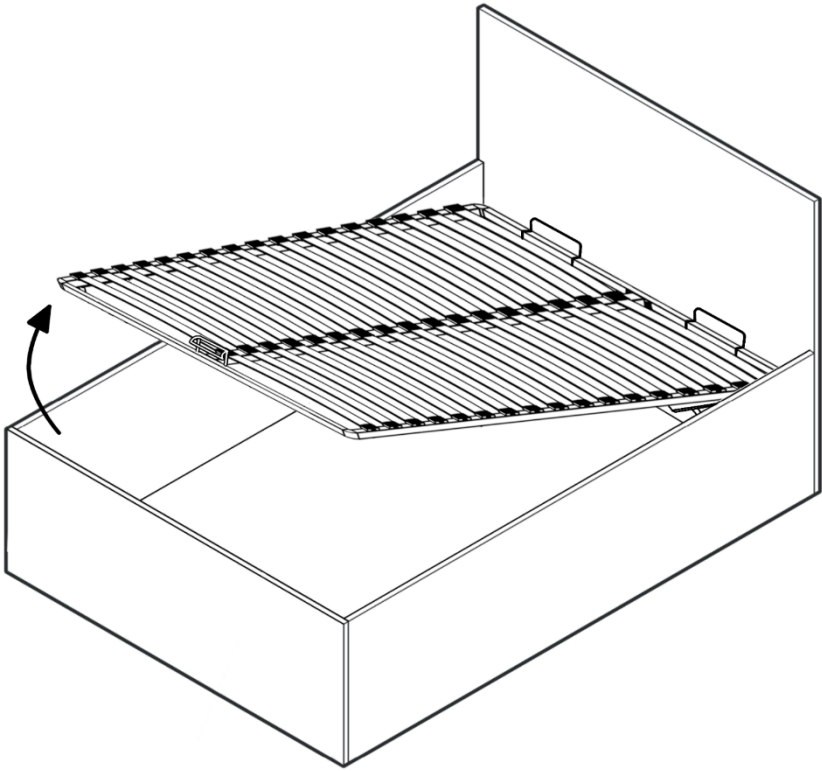

8

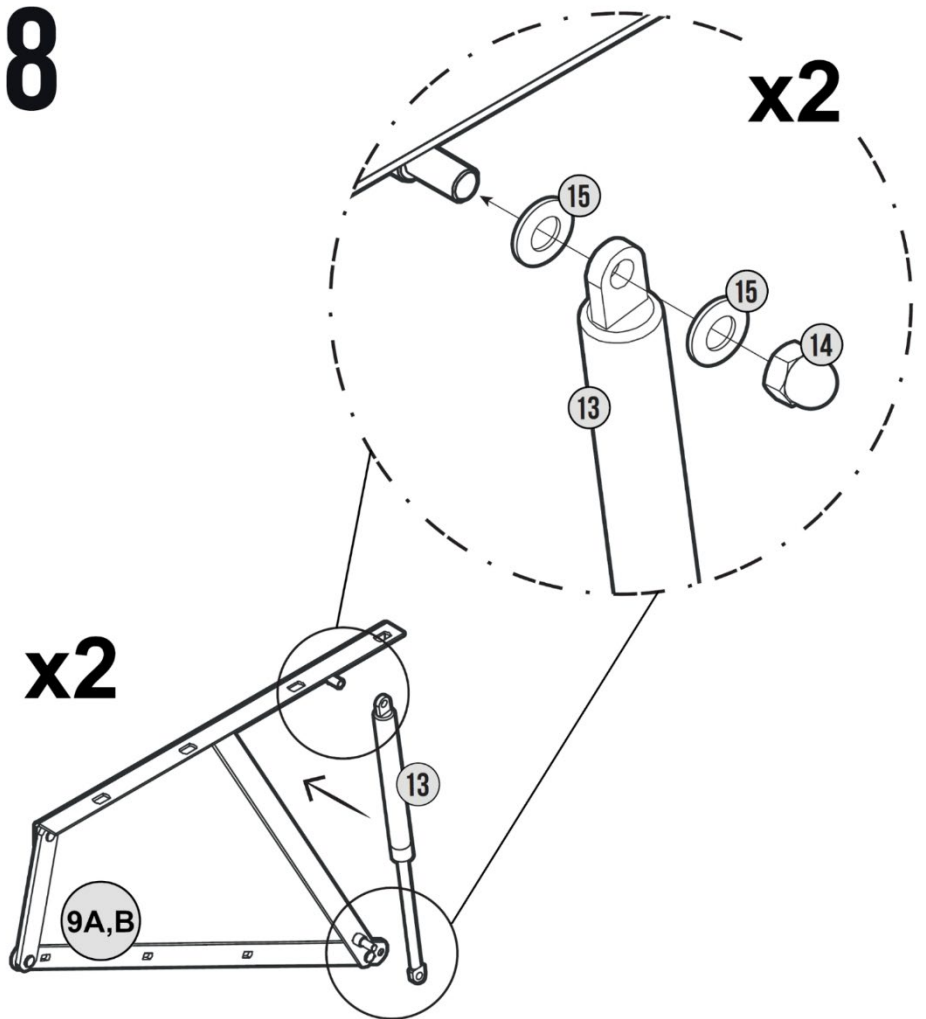

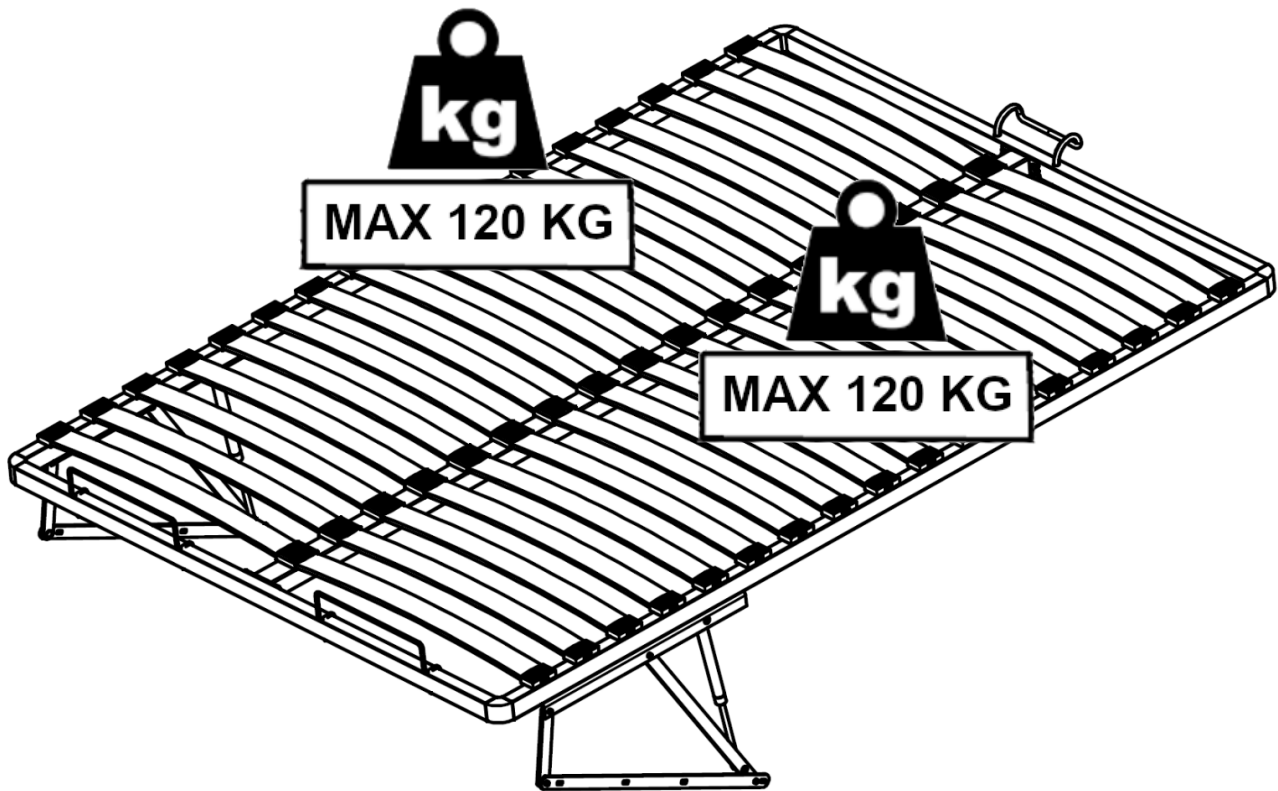

Importe par- Imported by- Importiert von- Importado por- Importato da- Geïmporteerd door-  
Importado por- Importowane przez:

[VENTE-UNIQUE.COM](http://VENTE-UNIQUE.COM)

9 Rue Jacquart 93310 Le Pré-Saint-Gervais

[gpsr@vente-unique.com](mailto:gpsr@vente-unique.com)

Fabriqué en Pologne/ Made in Poland/ Hergestellt in Polen/ Hecho en Polonia/ Prodotto in Polonia/  
Gemaakt in Polen/ Feito na Polônia/ Wyprodukowano w Polsce



# 3121L2C0

Fabriqué en  
  
 France

MINI 17Kg / 37.4lb  
 MAXI 25Kg / 55.1lb

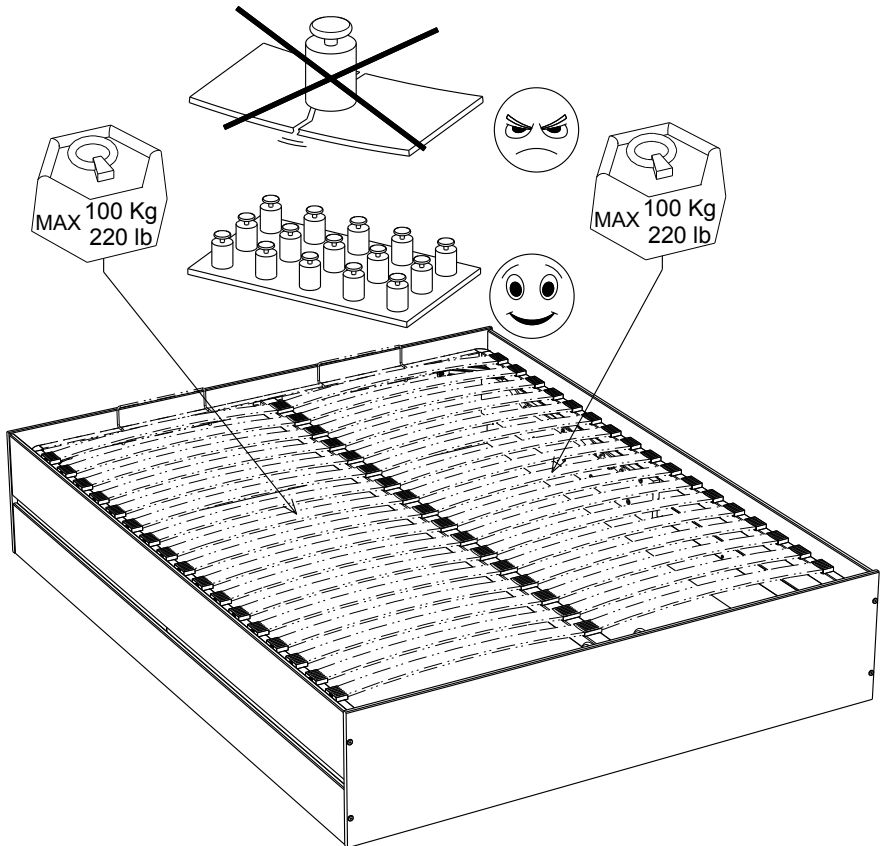
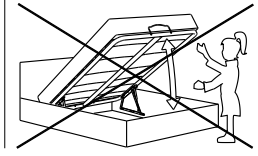
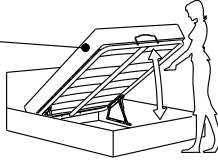

Gamme : STAMP

  
**PARISOT INDUSTRIE**

### FR Remerciements :

Nous vous remercions d'avoir choisi un meuble créé et fabriqué par le Groupe Parisot et espérons qu'il vous donnera entière satisfaction.

### EN Thanks:

Thank you for choosing furniture designed and manufactured by the Parisot Group. We hope you are totally satisfied with your purchase.

### DE Danksagung:

Wir danken Ihnen für den Kauf eines Frankreich von der Parisot-Gruppe entworfenen und hergestellten Möbelstücks und hoffen, dass Sie es zu Ihrer vollkommenen Zufriedenheit finden werden.

### HU Köszönet:

Köszönjük, hogy a Parisot Groupe által létrehozott és gyártott bútort választott, reméljük, hogy elégedett lesz a termékkel.

### PT Agradecimentos:

Obrigado por ter escolhido um móvel concebido e fabricado pelo Grupo Parisot, esperando que seja do seu inteiro agrado.

### IT Ringraziamenti:

Grazie per avere scelto un mobile progettato e fabbricato dal Gruppo Parisot. Speriamo soddisfatti appieno le vostre esigenze.

### NL Bedankje:

Wij bedanken u voor de aankoop van een door de Groep Parisot ontworpen en vervaardigd meubel en hopen dat u er veel plezier aan zult beleven.

### CZ Poděkování:

Děkujeme, že jste si vybrali nábytek navržený a vyrobený společností Parisot Group. Doufáme, že budete svým nákupem naprosto spokojeni.

### ES Agradecimientos:

Les damos las gracias por haber elegido un mueble diseñado y fabricado por el Grupo Parisot y esperamos que sea de su total agrado.

### PL Podziękowania:

Dziękujemy za wybór mebli stworzonych i wyprodukowanych przez Grupę Parisot. Mamy nadzieję, że będziecie Państwo w pełni zadowoleni z zakupu.

### SK Pod'akovanie:

Ďakujeme, že ste si vybrali nábytok navrhnutý a vyrobený spoločnosťou Parisot Group. Dúfame, že budete svojim nákupom absolútne spokojní.

### AR شكر:

نشكركم لاختياركم هذه القطعة من الأثاث من تصميم وتصنيع مجموعة باريسو Parisot ونتمنى أن تتال رضاءكم.

## PARISOT INDUSTRIE

15 Avenue Jacques Parisot, 70800 Saint-Loup sur Semouse  
contact@parisot.com  
RCS VESOUL 537 665 200

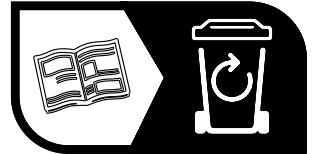
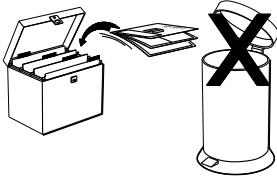

FR

Donnez ou recyclez  
vos meubles.



Association



Magasin



Déchèterie

<https://quefairedemesdechets.fr>

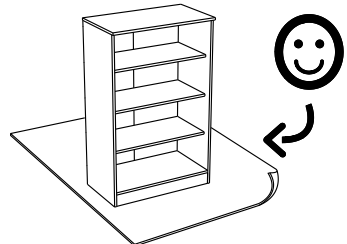
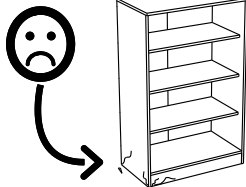
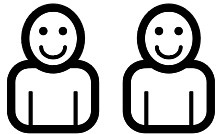
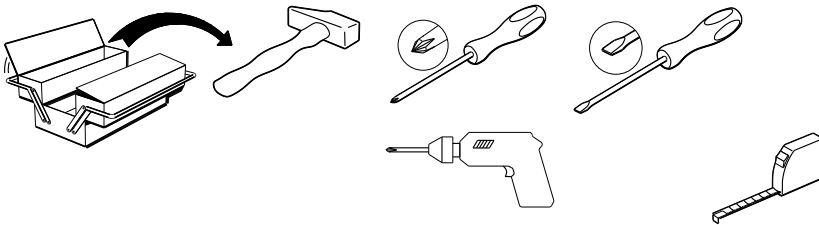

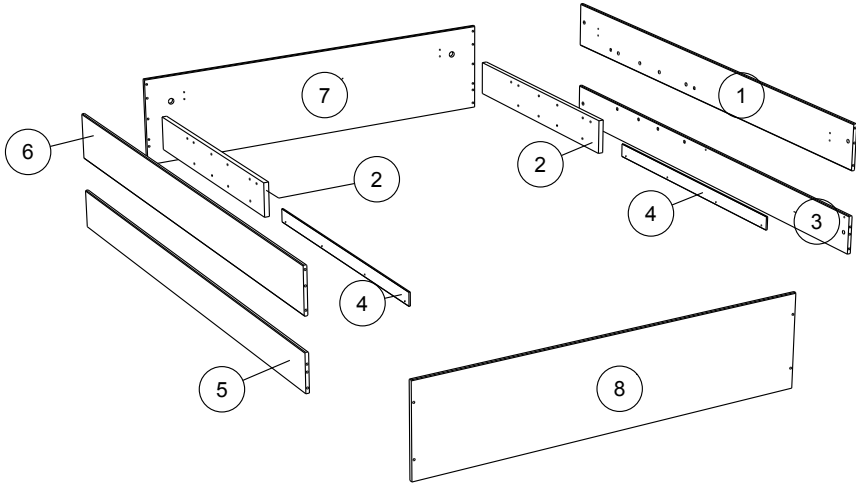
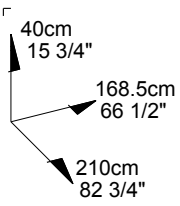

		mm			inch		
②	x 2	1005	150	22	39 9/16	5 15/16	7/8
④	x 2	1062	57	6	41 13/16	2 1/4	1/4
⑦	x 1	1683	398	15	66 1/4	15 11/16	9/16
⑧	x 1	1683	398	15	66 1/4	15 11/16	9/16
③	x 1	2068	166	15	81 7/16	6 9/16	9/16
⑤	x 1	2068	166	15	81 7/16	6 9/16	9/16
①	x 1	2068	201	15	81 7/16	7 15/16	9/16
⑥	x 1	2068	201	15	81 7/16	7 15/16	9/16

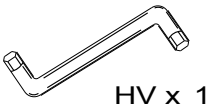

HV x 1



AHX x 8



BLR x 4



AHZ x 1

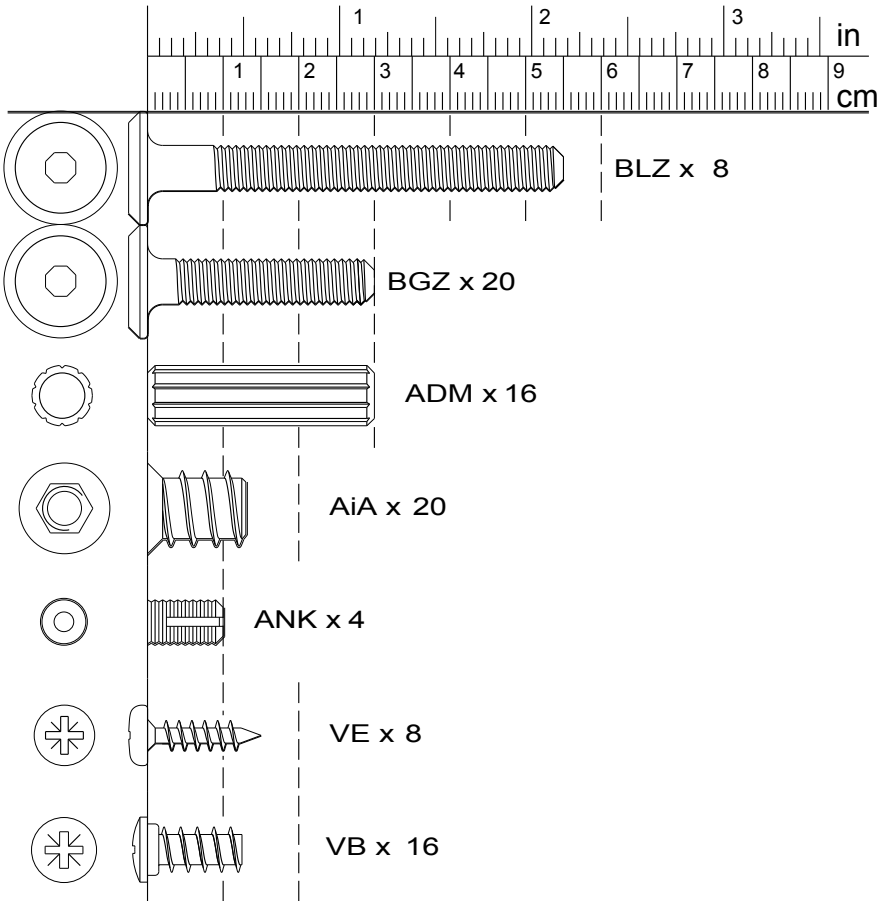

1

ADM x 8

AHX x 4

AiA x 6

AHZ x 1

ANK x 2

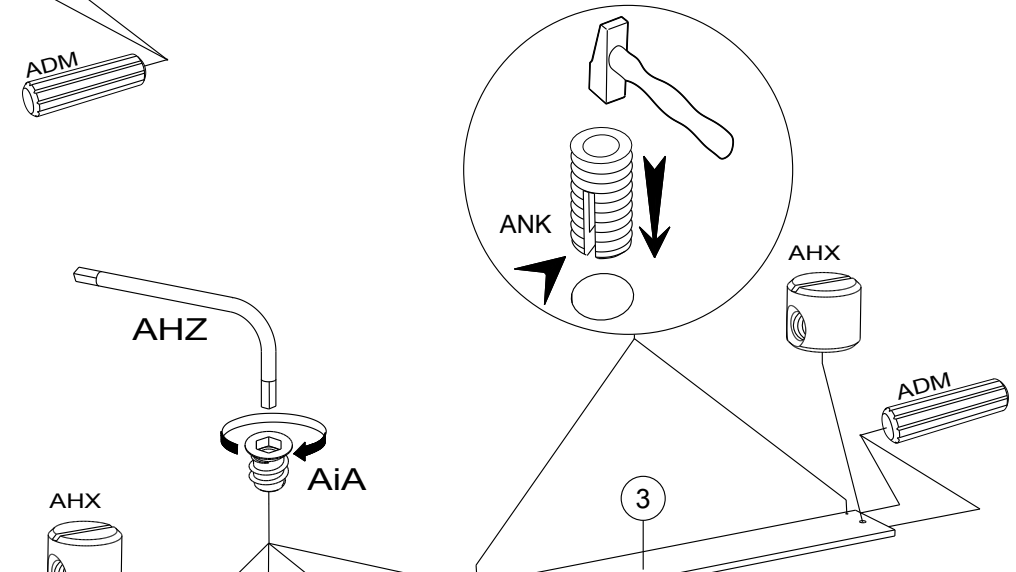
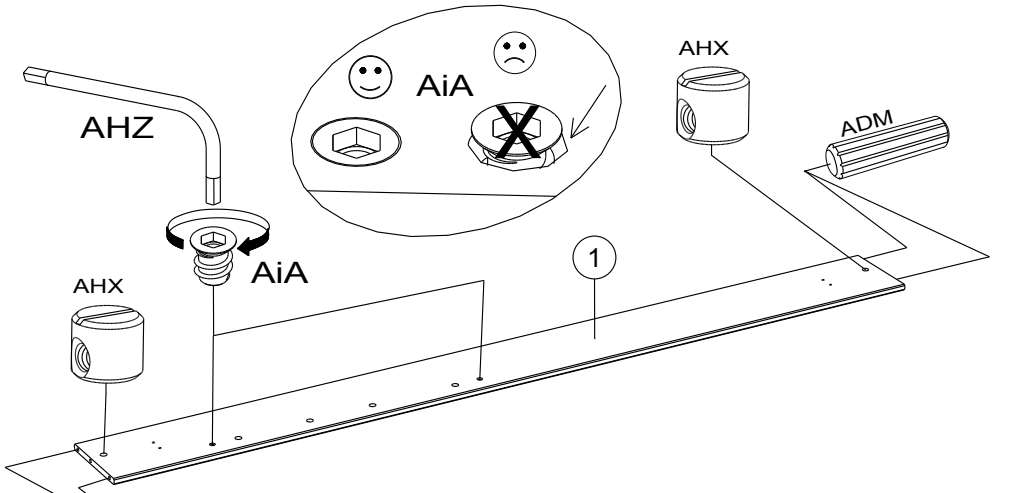

2

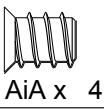

AiA x 4



AHZ x1

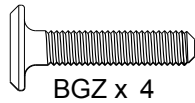

BGZ x 4



HV x1

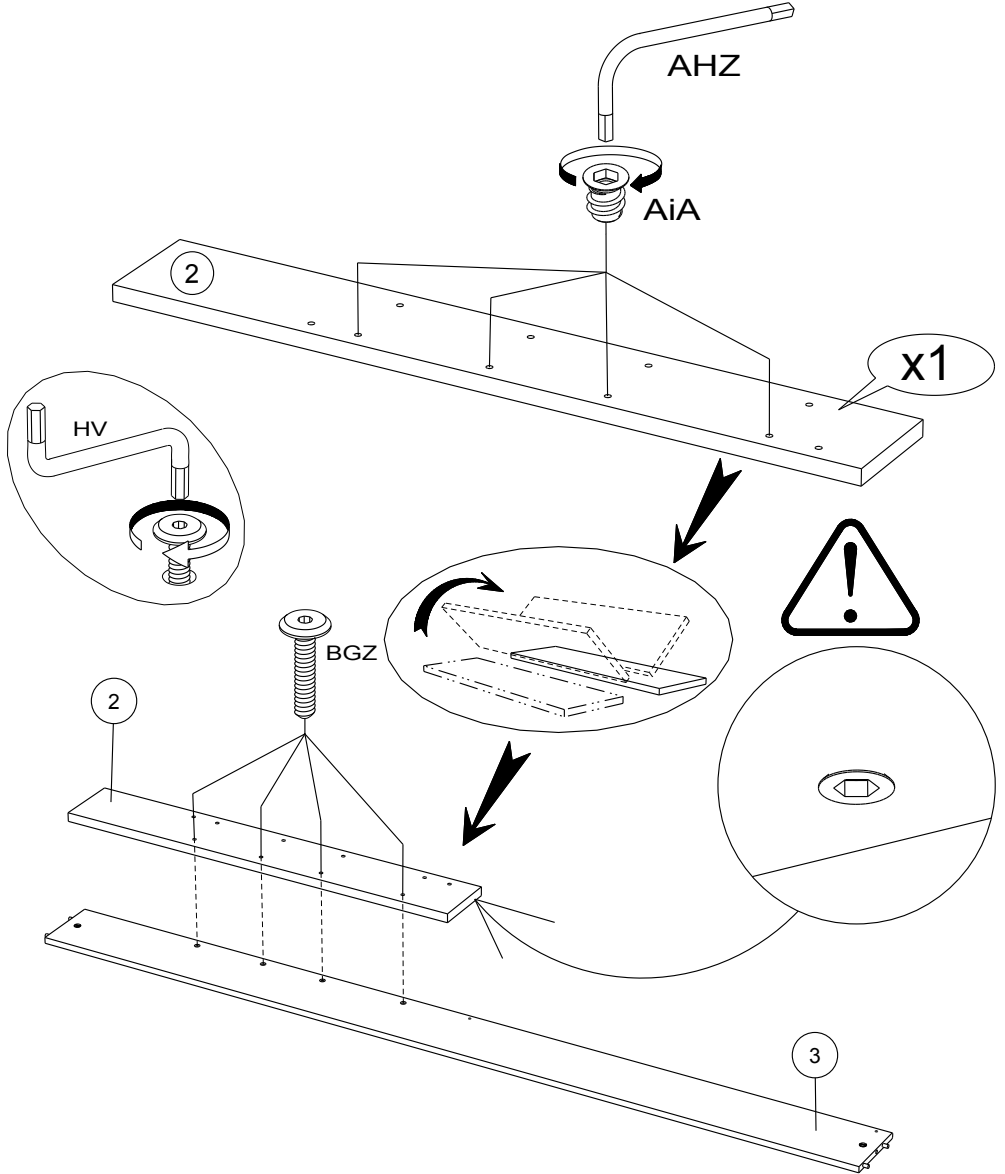

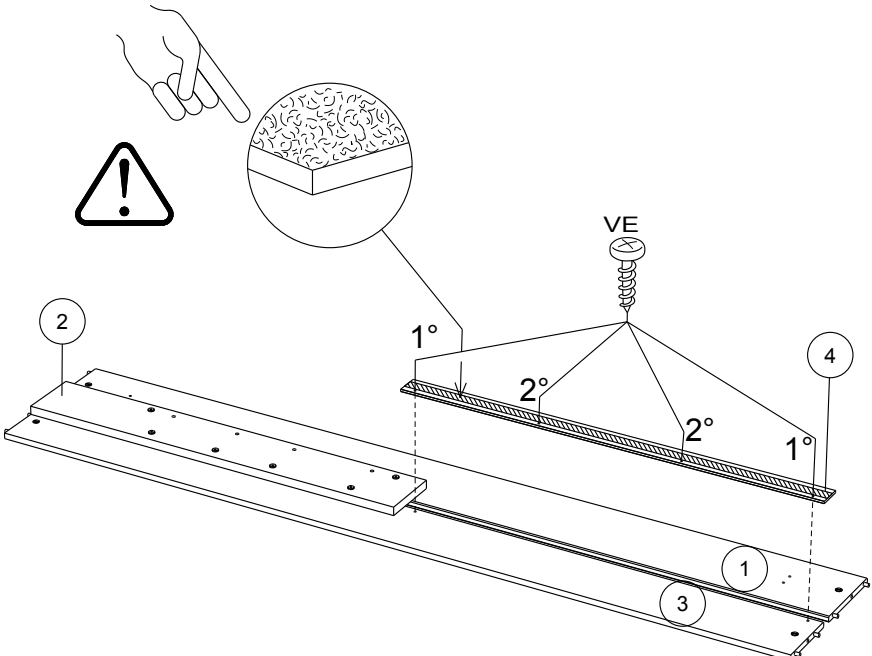
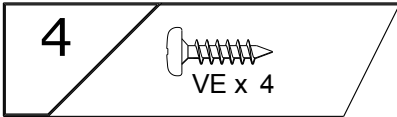
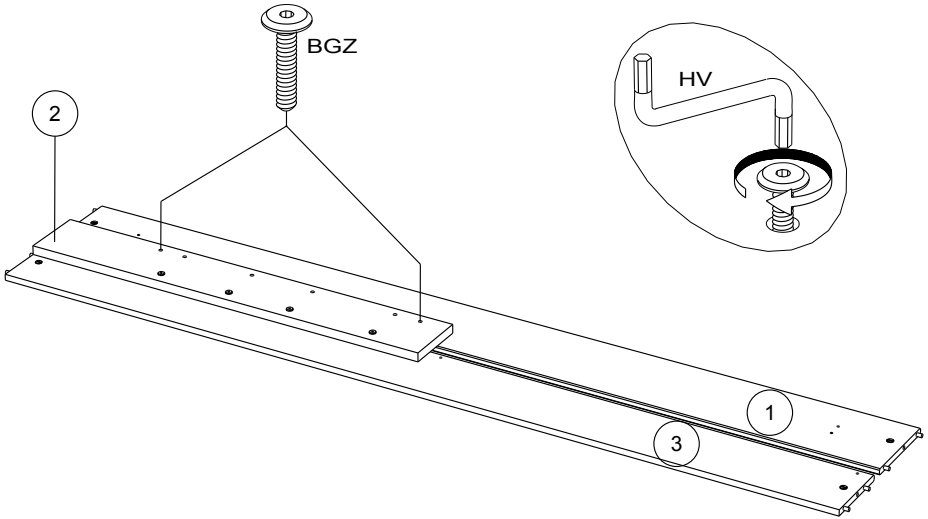
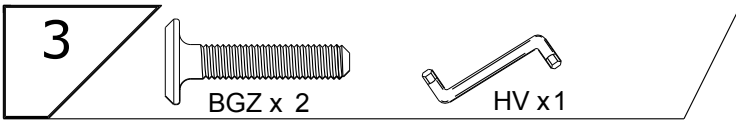

5

ADM x 8

ANK x 2

AiA x 6

AHZ x 1

AHX x 4

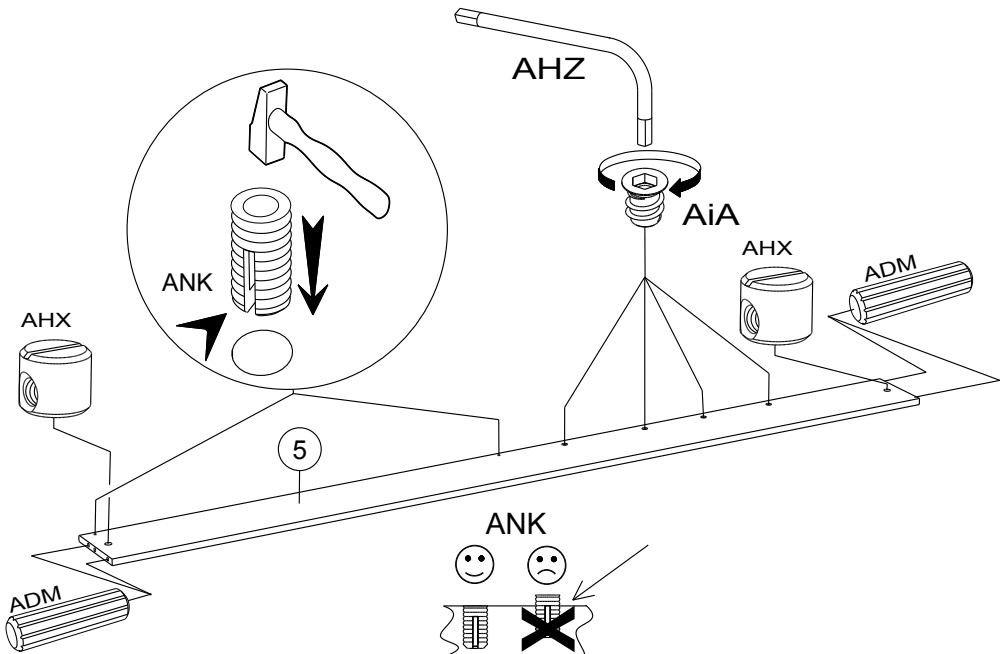
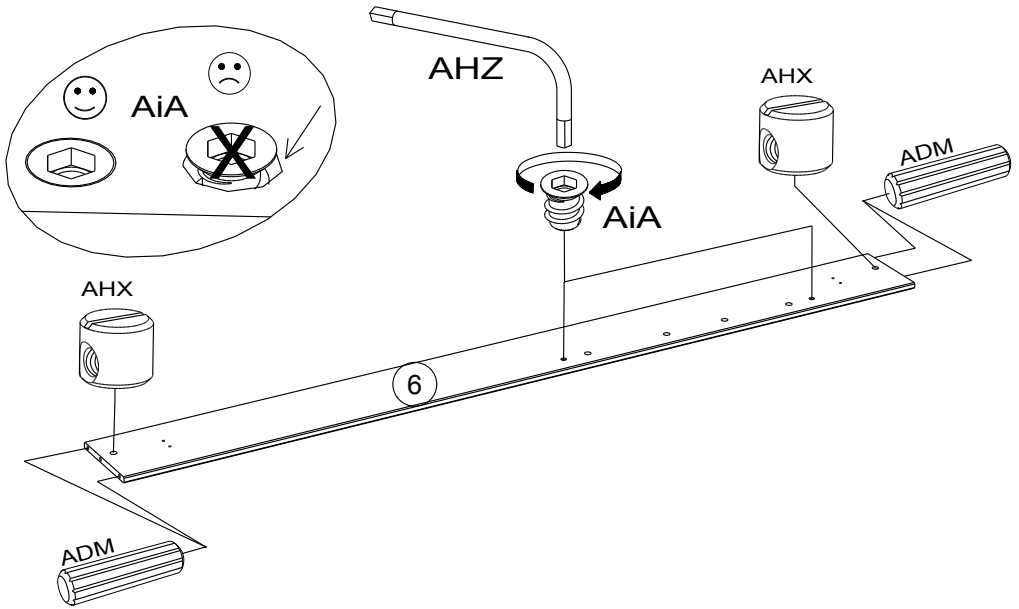

6



AiA x 4



AHZ x1

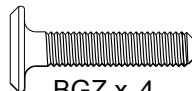

BGZ x 4



HV x1

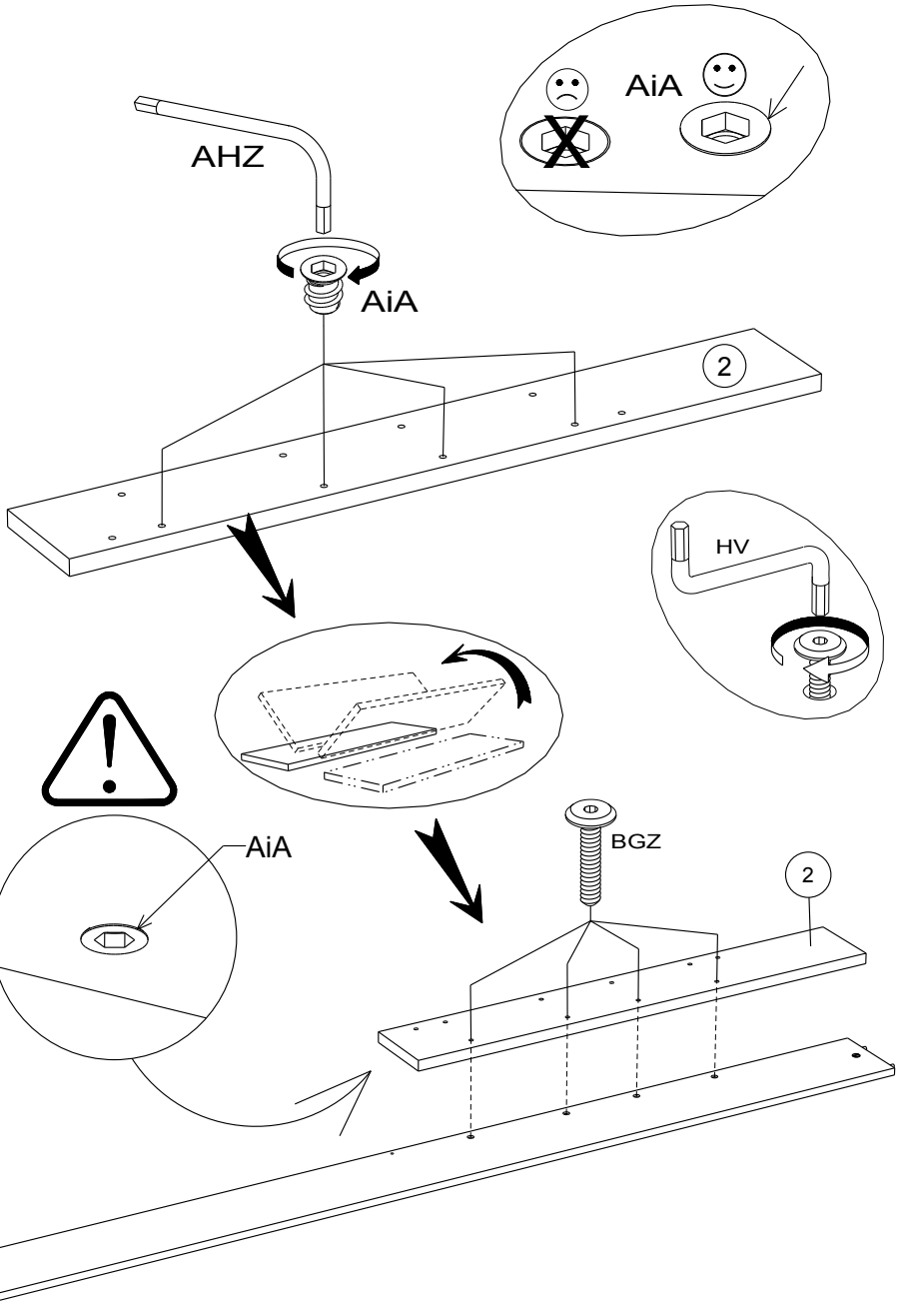

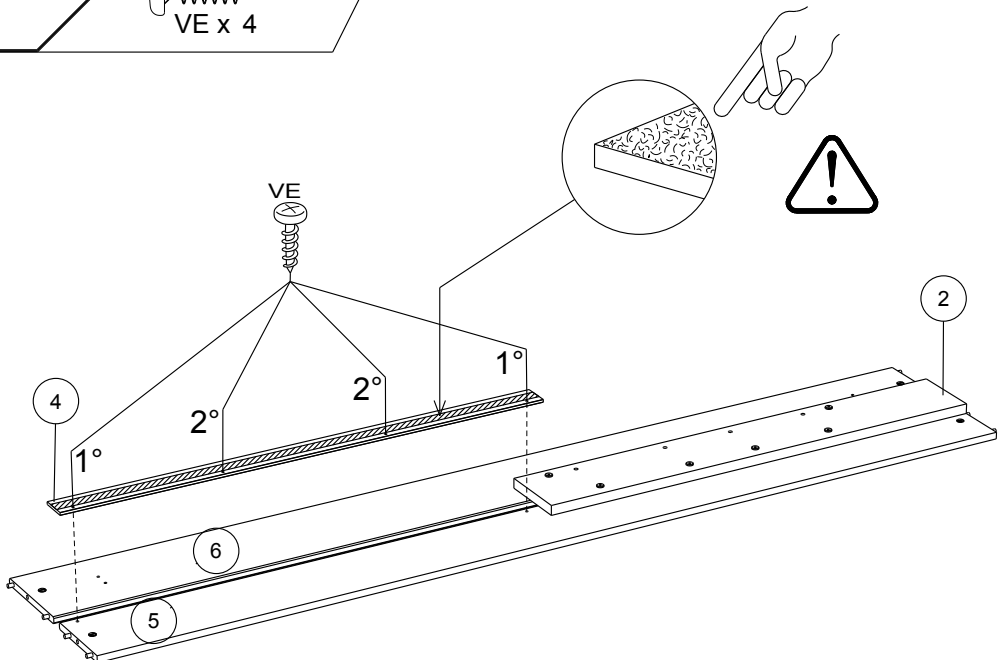
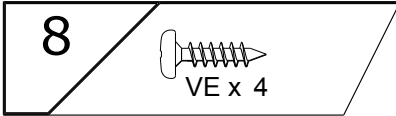
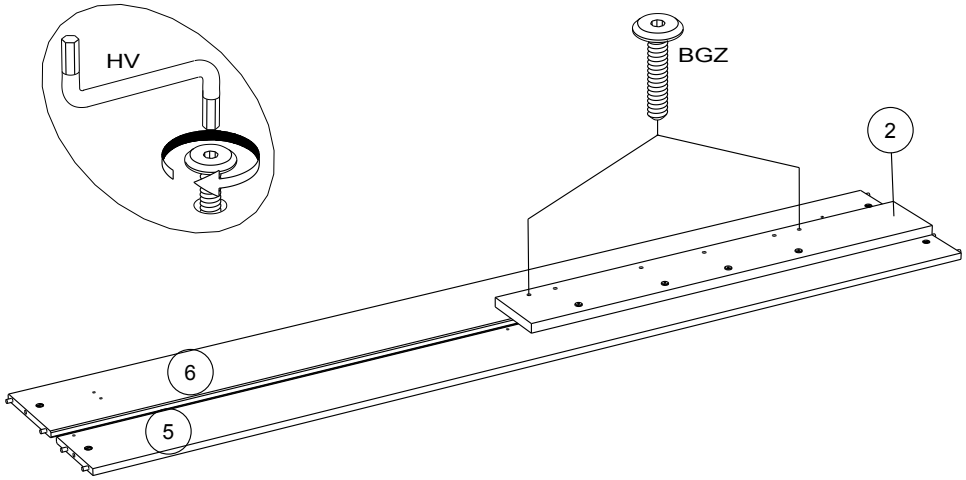
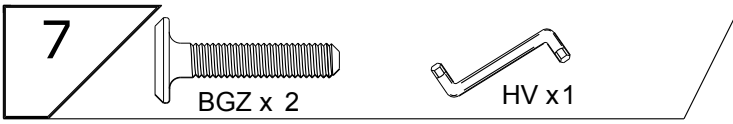

9

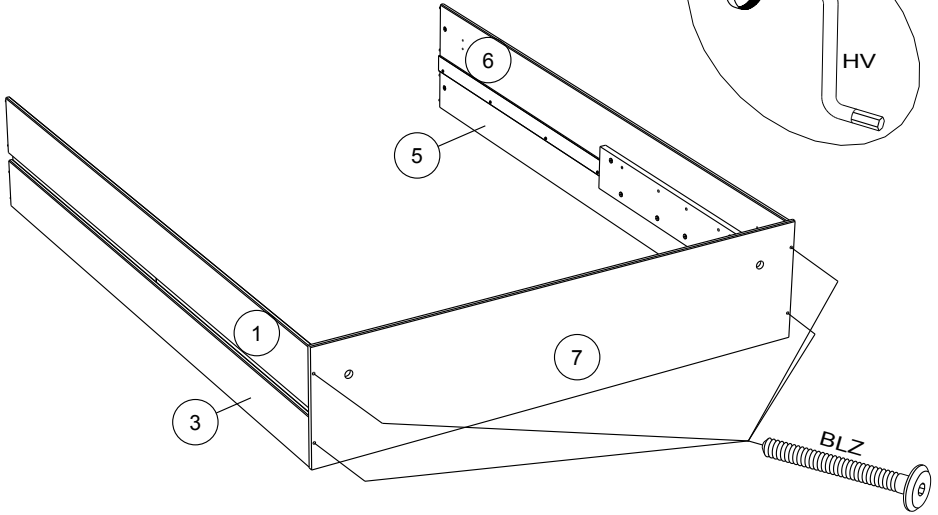
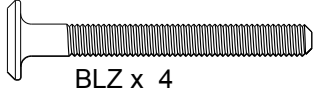

10

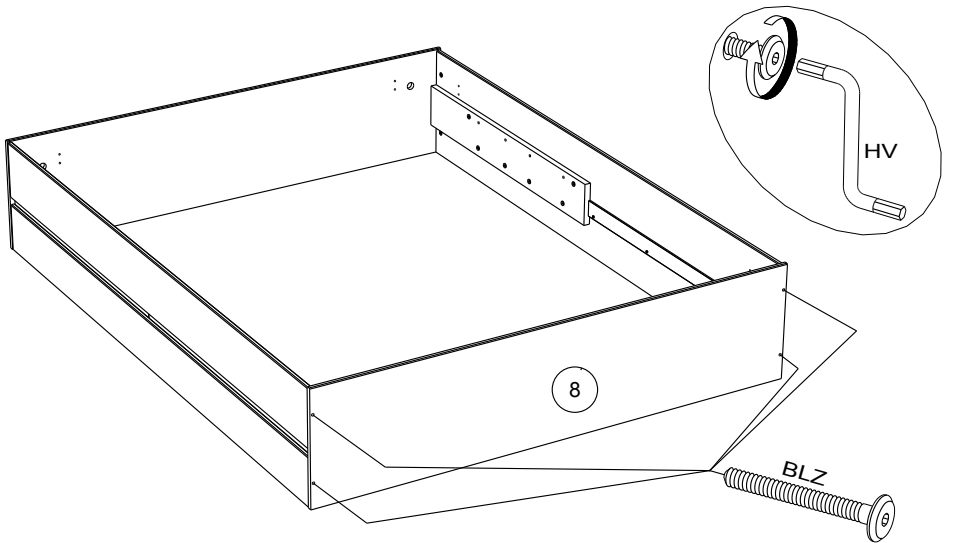
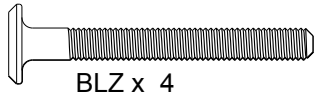

11



BLR x 4



VB x 16

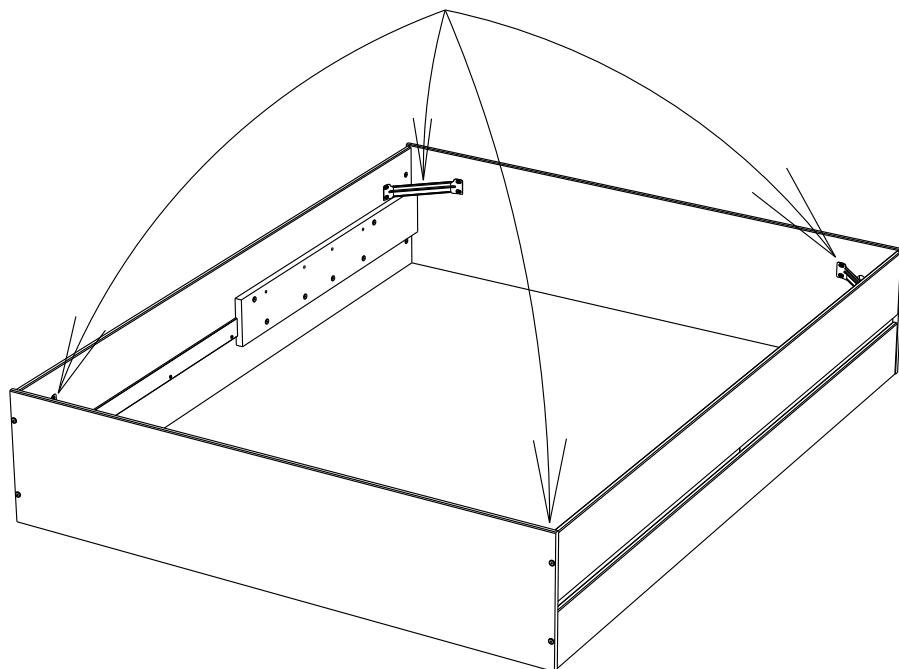
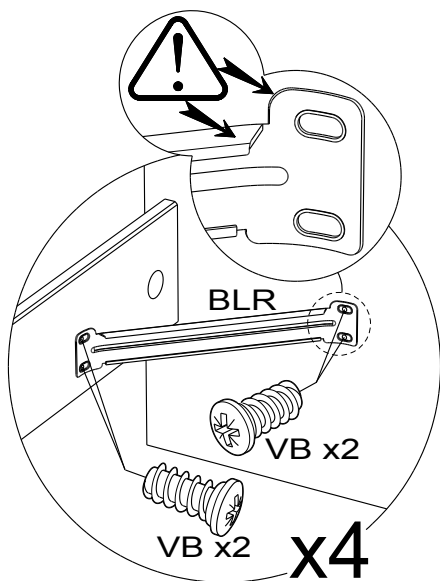

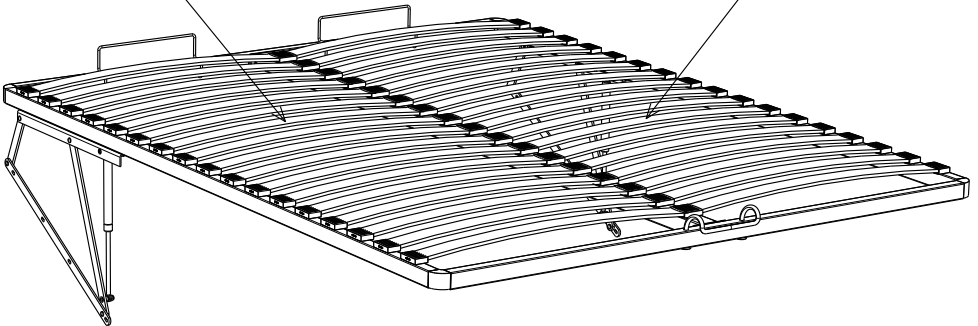
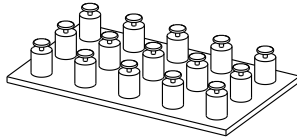
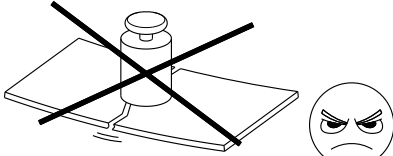
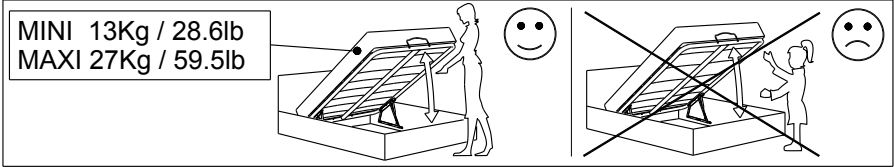
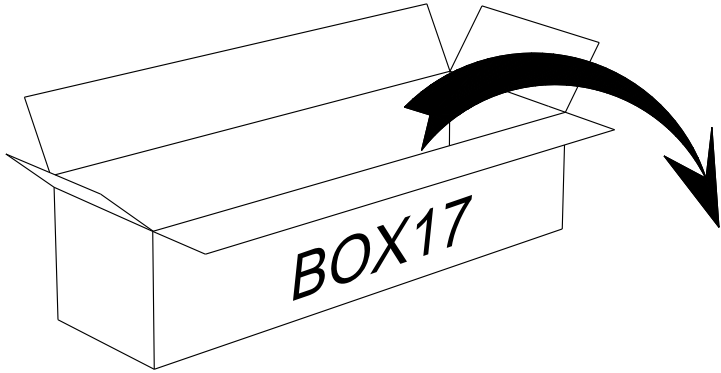

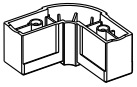

6 x4

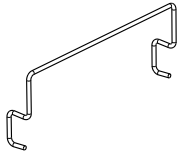

5 x2

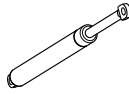

13 x2

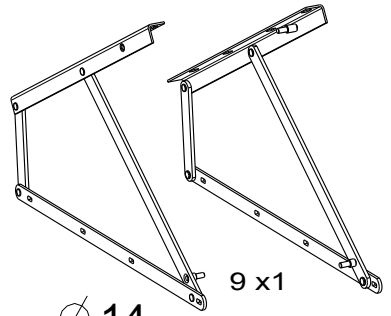

9 x1

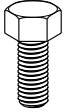

7 x12



18

16 x12



8 x8



14 x4



14

15 x8

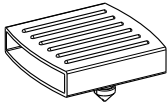

11 x17



10 x34

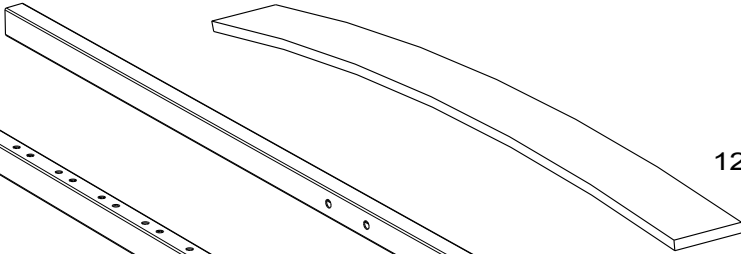

12 x34

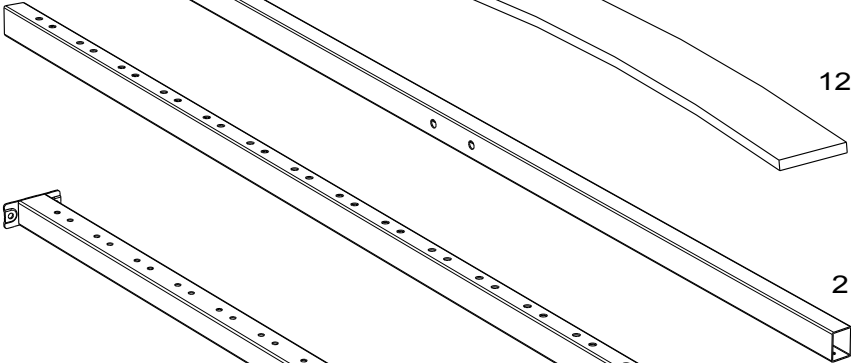

2 x1

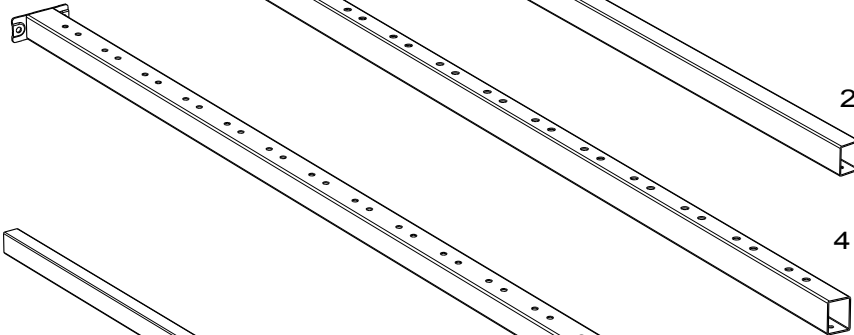

4 x2

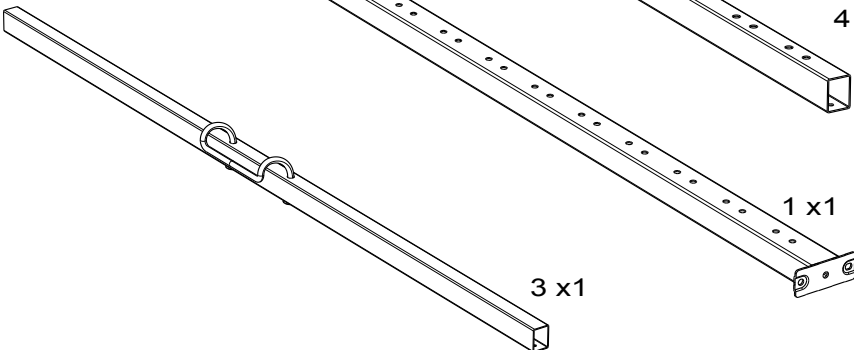

1 x1

3 x1

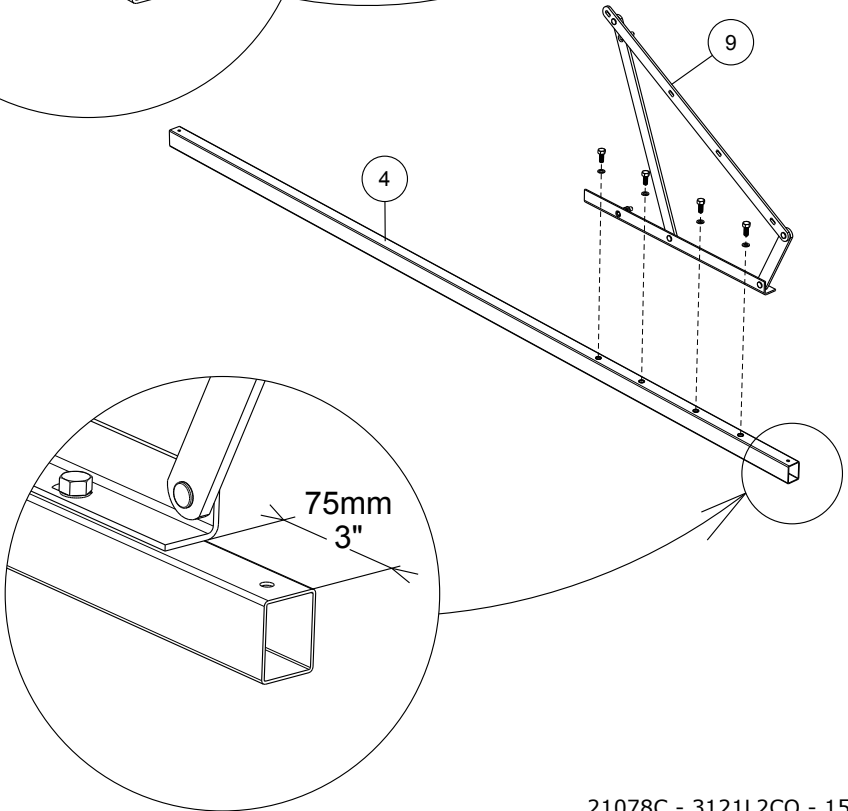
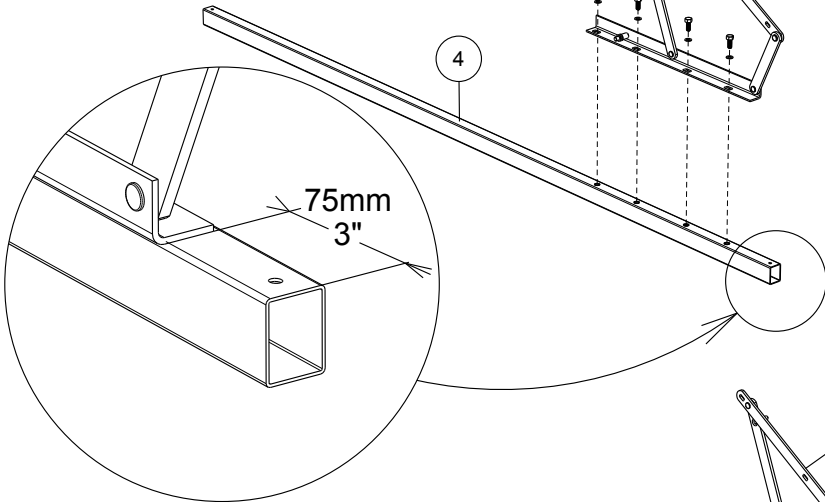
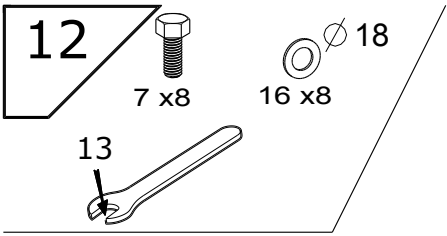

13

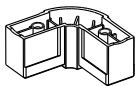

6 x4



8 x4

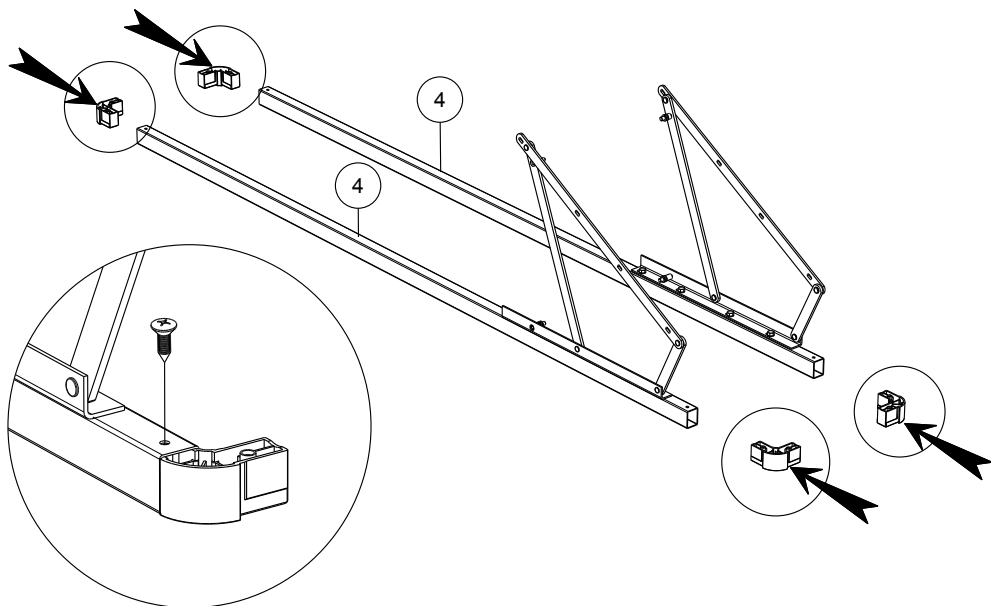

14



7 x4

13

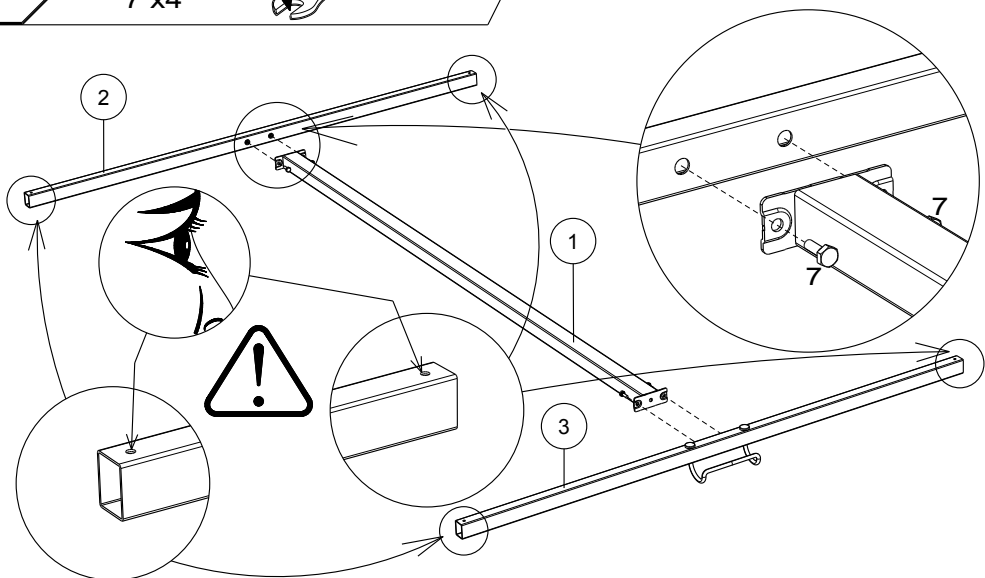

15

8 x 4

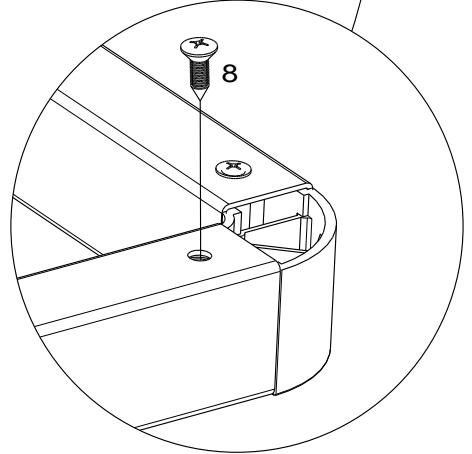
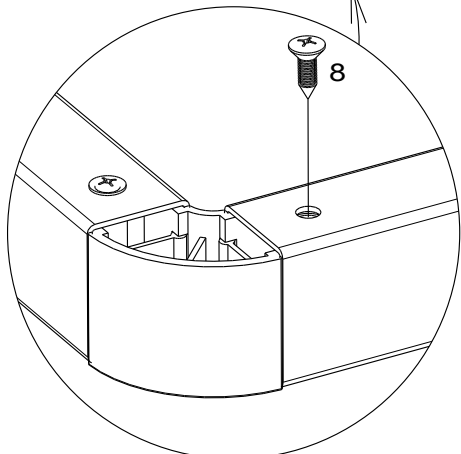
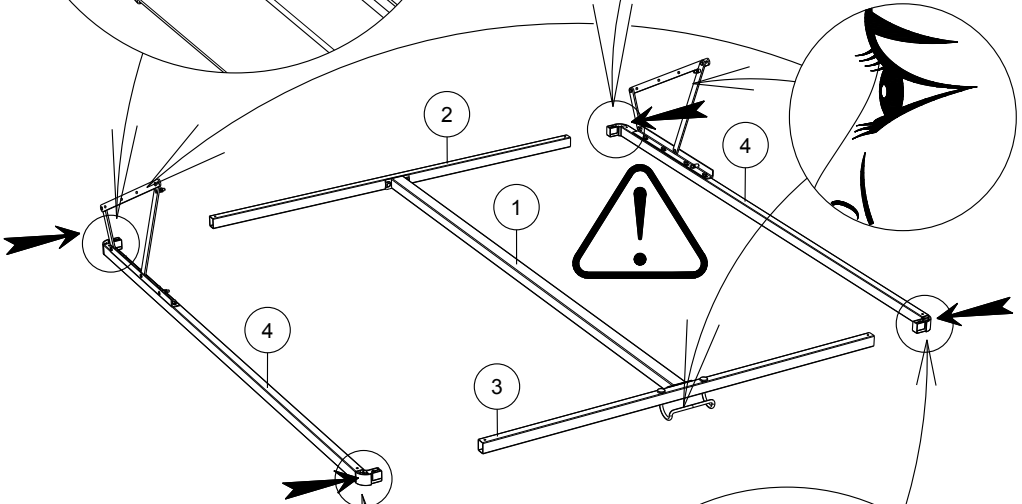
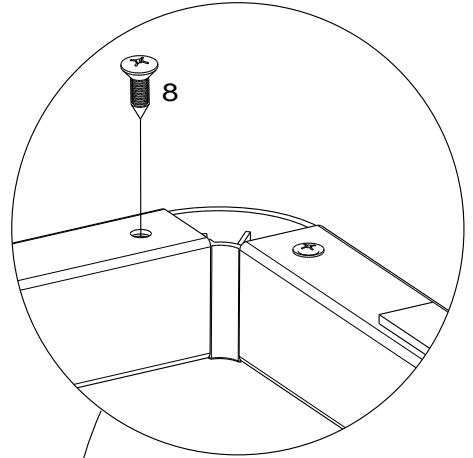
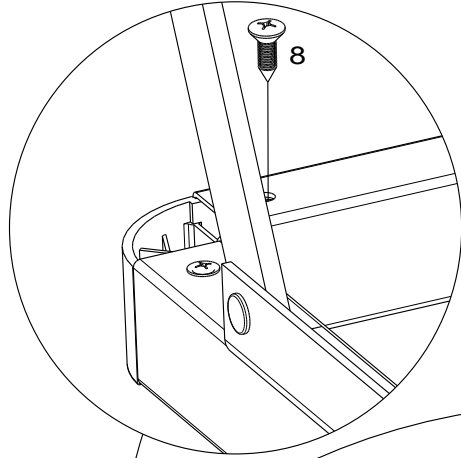

16

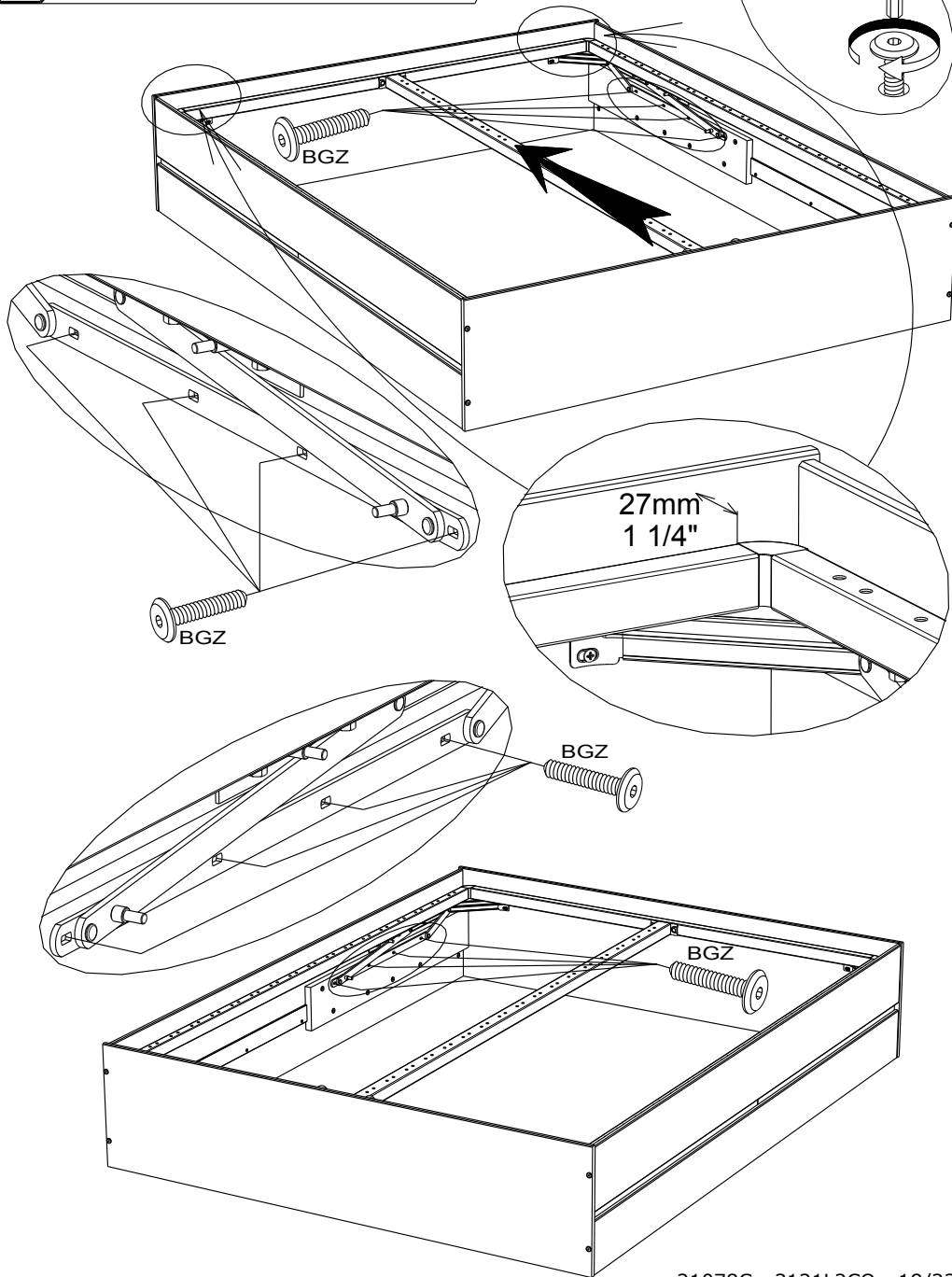
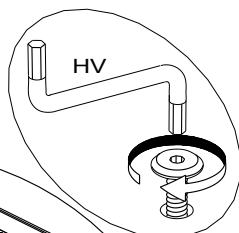
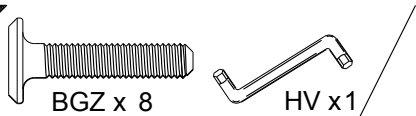

17

5 x 2

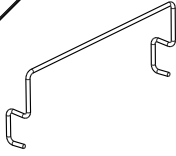

5

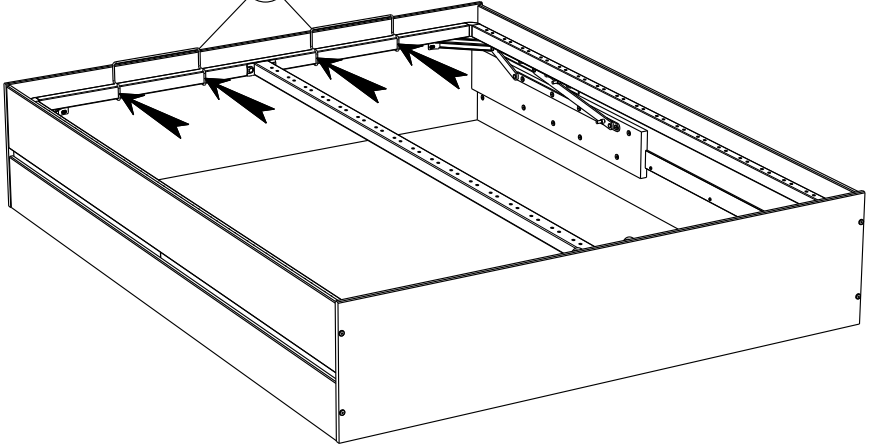

18

11 x 17

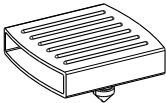

11

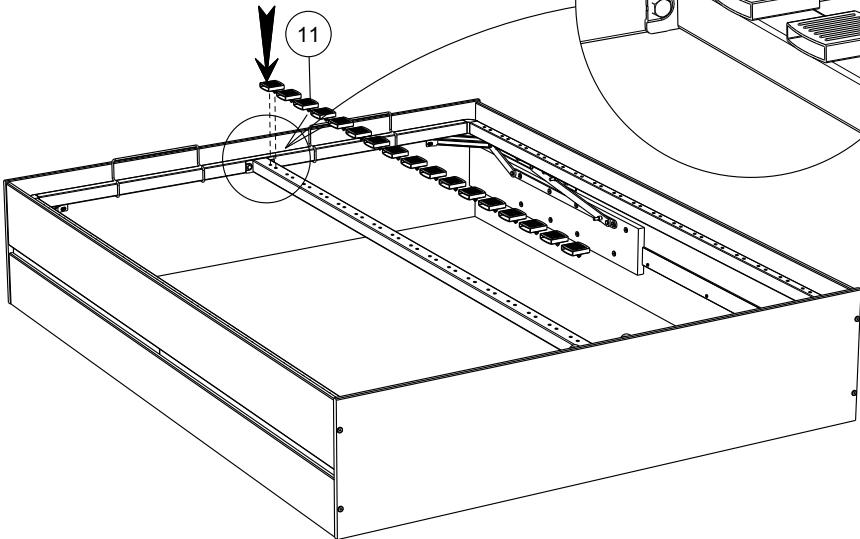
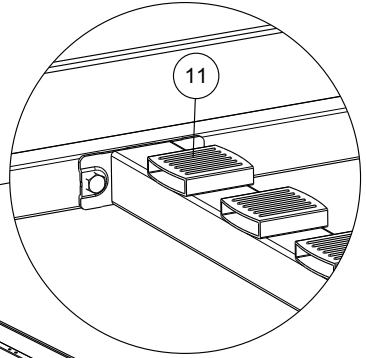

19



10 x 34

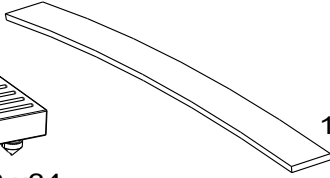

12 x 34

10

12

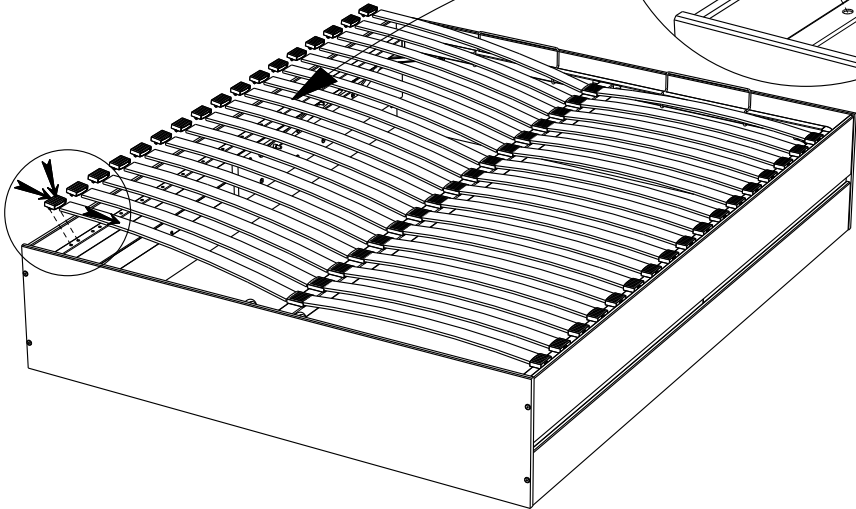
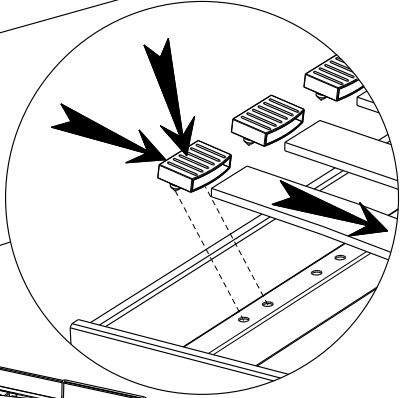
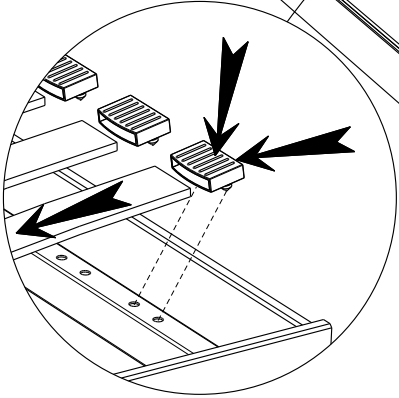
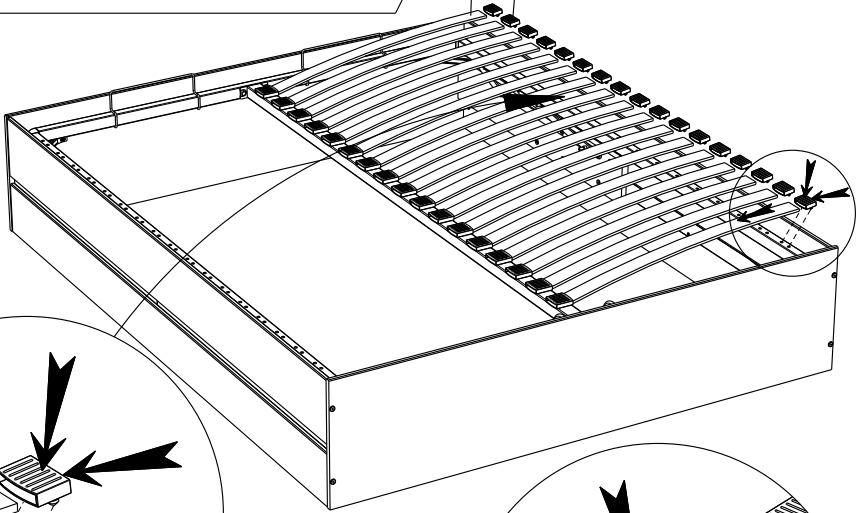

20

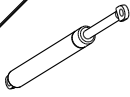

13 x 1



14 x 2



15 x 4

13

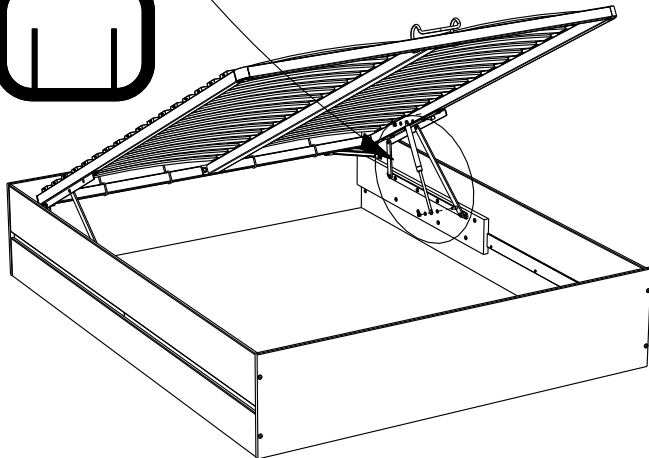
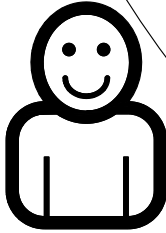
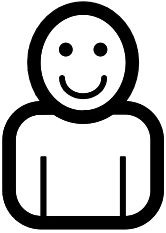
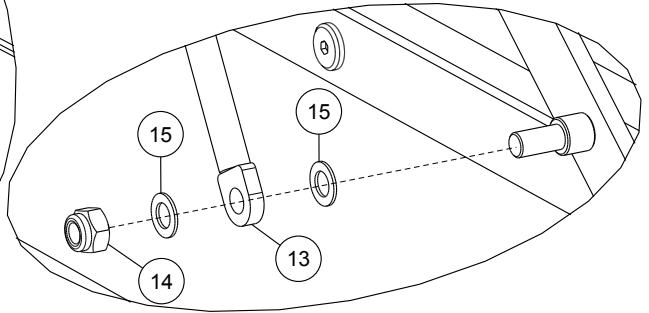
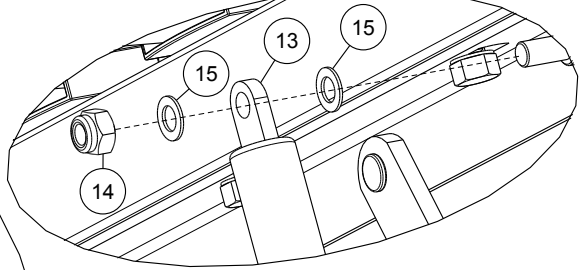
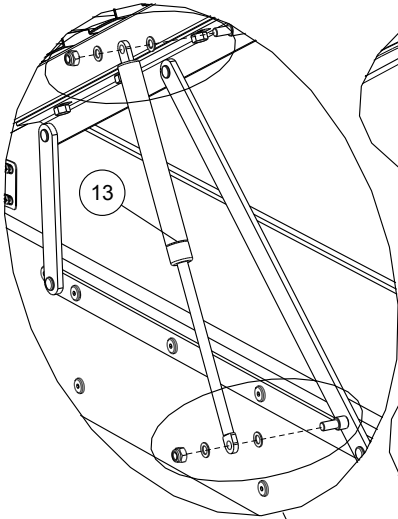

21

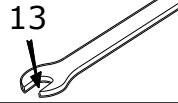
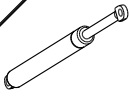

13 x1

14 x2

15 x4

13

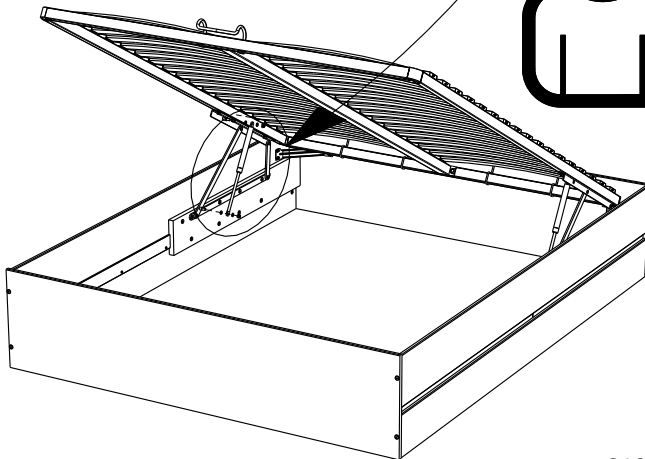
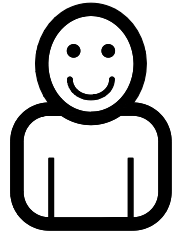
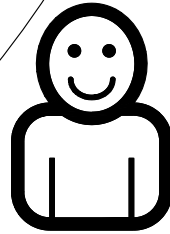
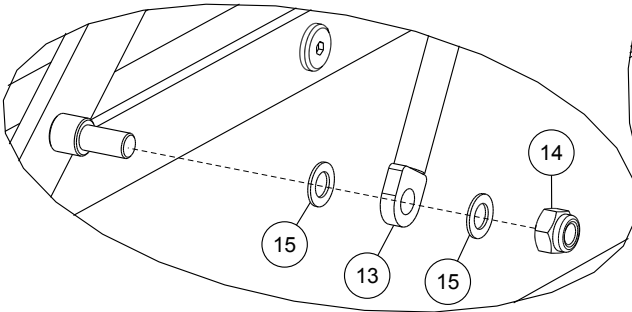
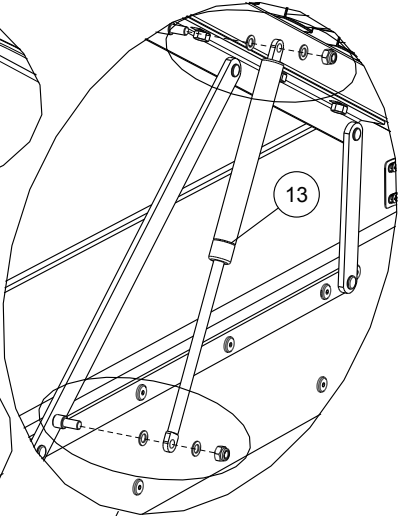
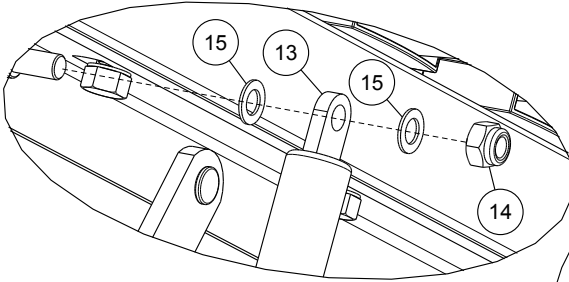

22

MINI 17Kg / 37.4lb  
MAXI 25Kg / 55.1lb

