

N634P456927 N634P456928 N634P456929

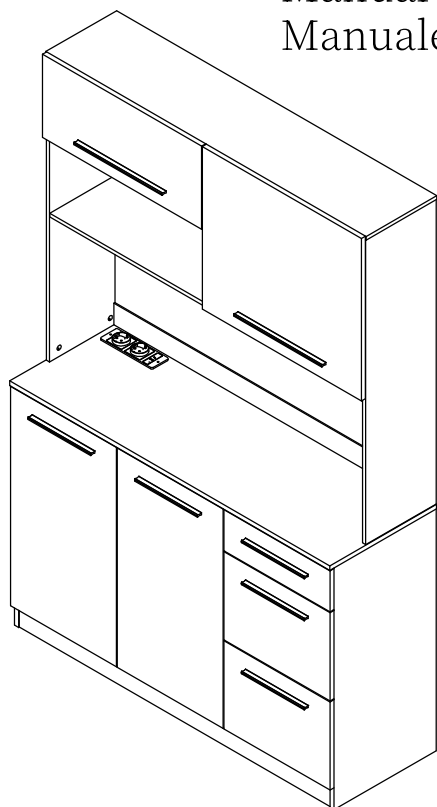

Product manual
Gebrauchsanweisung
Manuel du produit
Manual del producto
Manuale del prodotto



EN:Our product will be delivered to you in 2 packages. The delivery times of these 2 packages may differ, please be patient and thank you for your understanding
FR:Notre produit vous sera livré en 2 colis. Les délais de livraison de ces 2 colis peuvent différer, soyez patient et merci de votre compréhension.
DE:Unser Produkt wird Ihnen in 2 Paketen geliefert. Die Lieferzeiten dieser 2 Pakete können abweichen, bitte haben Sie etwas Geduld und vielen Dank für Ihr Verständnis
IT:I nostri prodotti vengono trasportati in due pacchetti. I tempi di consegna dei due pacchetti sono diversi: abbiate pazienza e vi ringrazio per la vostra comprensione.
ES:Nuestro producto se entrega en dos paquetes. El tiempo de entrega de estos dos paquetes es diferente. Por favor, sea paciente. Gracias por su comprensión.



FR
Cet appareil,
ses cordons,
et batterie
se recyclent

À DÉPOSER
EN MAGASIN

OU

À DÉPOSER
EN DÉCHÈTERIE

Points de collecte sur www.quefairedemesdechets.fr
Privilégiez la réparation ou le don de votre appareil !



2PERS



90 MIN

Tool Required Not Provided

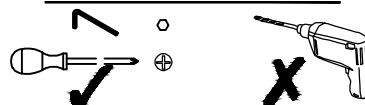



[DE]

Warnung: Lesen Sie die Anleitung vor dem Zusammenbau bitte vollständig durch. Überprüfen Sie, ob Sie alle auf den Seiten aufgeführten Komponenten und Werkzeuge haben.

Warnung: Legen Sie alle Teile auf eine ebene Fläche. Legen Sie eine weiche Decke oder Ähnliches darunter, um sie vor Kratzern oder Flecken zu schützen. Vermeiden Sie es, Komponenten über den Boden zu ziehen oder zu schieben.

Warnung: Überprüfen Sie regelmäßig alle Beschläge und Befestigungen, um sicherzustellen, dass sie sicher sind und um Unfälle zu vermeiden. Wenn Teile fehlen, kaputt, beschädigt oder abgenutzt sind, verwenden Sie das Produkt nicht weiter, bis es mit vom Hersteller autorisierten Teilen repariert wurde.

Warnung: Lassen Sie Kinder nicht auf die Möbel klettern, da dies zum Umkippen und zu schweren Verletzungen führen kann. Bauen Sie die Möbel außerhalb der Reichweite von Kindern zusammen.

Warnung: Stellen Sie die Möbel nicht in die Nähe von Feuerquellen oder heißen Gegenständen, um Brandgefahr zu vermeiden.

Warnung: Reinigen Sie die Möbel mit einem feuchten Tuch oder Alkohol. Verwenden Sie keine Reinigungsmittel mit ätzenden Chemikalien.

Warnung: Dieses Produkt ist mit einer Kippschutzvorrichtung ausgestattet. Bitte installieren Sie diese Vorrichtung unbedingt, um unnötige Verletzungen durch Umkippen zu vermeiden.

[EN]

Warning: Please read instructions fully before starting assembly. Check you have all the components and tools listed on pages.

Warning: Please place all parts on a flat surface. Place a soft blanket or similar underneath to protect against scratches or stains. Avoid dragging or sliding components across the floor.

Warning: Regularly check all fittings and fastenings to ensure they are secure and to prevent accidents. If any parts are missing, broken, damaged, or worn, discontinue use of the product until repairs have been made using factory authorized parts.

Warning: Do not allow children to climb on the furniture as this may result in tipping and serious personal injury. Assemble the furniture away from the reach of children.

Warning: Do not place furniture close to fire sources or high-temperature objects to avoid the risk of fire

Warning: Clean furniture with a damp cloth or alcohol, avoid using cleaning agents containing corrosive chemicals.

Warning: This product is equipped with an anti-tilt device. Please be sure to install this device to prevent unnecessary injuries caused by tipping.

[FR]

Avertissement : Veuillez lire entièrement les instructions avant de commencer l'assemblage. Vérifiez que vous disposez de tous les composants et outils répertoriés sur les pages.

Avertissement : Veuillez placer toutes les pièces sur une surface plane. Placez une couverture douce ou similaire en dessous pour les protéger des rayures ou des taches. Évitez de faire glisser les composants sur le sol.

Avertissement : Vérifiez régulièrement tous les raccords et fixations pour vous assurer qu'ils sont bien fixés et pour éviter les accidents. Si des pièces manquent, sont cassées, endommagées ou usées, cessez d'utiliser le produit jusqu'à ce que des réparations aient été effectuées à l'aide de pièces autorisées par l'usine.

Avertissement : Ne laissez pas les enfants grimper sur les meubles car cela pourrait entraîner un basculement et des blessures graves. Assemblez les meubles hors de portée des enfants.

Avertissement : Ne placez pas les meubles à proximité de sources de feu ou d'objets à haute température pour éviter tout risque d'incendie.

Avertissement : Nettoyez les meubles avec un chiffon humide ou de l'alcool, évitez d'utiliser des produits de nettoyage contenant des produits chimiques corrosifs.

Avertissement : Ce produit est équipé d'un dispositif anti-basculement. Assurez-vous d'installer ce dispositif pour éviter les blessures inutiles causées par un basculement.

[IT]

Attenzione: leggere attentamente le istruzioni prima di iniziare il montaggio. Verificare di avere tutti i componenti e gli strumenti elencati nelle pagine.

Attenzione: posizionare tutte le parti su una superficie piana. Posizionare una coperta morbida o simile sotto per proteggere da graffi o macchie. Evitare di trascinare o far scivolare i componenti sul pavimento.

Attenzione: controllare regolarmente tutti i raccordi e i dispositivi di fissaggio per assicurarsi che siano sicuri e per prevenire incidenti. Se alcune parti sono mancanti, rotte, danneggiate o usurate, interrompere l'uso del prodotto fino a quando non siano state eseguite le riparazioni utilizzando parti autorizzate dalla fabbrica.

Attenzione: non consentire ai bambini di arrampicarsi sui mobili poiché ciò potrebbe causare ribaltamenti e gravi lesioni personali. Montare i mobili lontano dalla portata dei bambini.

Attenzione: non posizionare i mobili vicino a fonti di fuoco o oggetti ad alta temperatura per evitare il rischio di incendio

Attenzione: pulire i mobili con un panno umido o alcol, evitare di utilizzare detergenti contenenti sostanze chimiche corrosive.

Attenzione: questo prodotto è dotato di un dispositivo antiribaltamento. Assicurarsi di installare questo dispositivo per prevenire lesioni inutili causate dal ribaltamento.

[ES]

Advertencia: Lea las instrucciones completamente antes de comenzar el montaje. Compruebe que tiene todos los componentes y herramientas que se enumeran en las páginas.

Advertencia: Coloque todas las piezas sobre una superficie plana. Coloque una manta suave o algo similar debajo para protegerlas de rayones o manchas. Evite arrastrar o deslizar los componentes por el piso.

Advertencia: Verifique regularmente todos los accesorios y fijaciones para asegurarse de que estén seguros y evitar accidentes. Si falta alguna pieza, está rota, dañada o desgastada, deje de usar el producto hasta que se hayan realizado las reparaciones con piezas autorizadas de fábrica.

Advertencia: No permita que los niños se suban a los muebles, ya que esto puede provocar que se vuelquen y lesiones personales graves. Monte los muebles fuera del alcance de los niños.

Advertencia: No coloque los muebles cerca de fuentes de fuego u objetos de alta temperatura para evitar el riesgo de incendio.

Advertencia: Limpie los muebles con un paño húmedo o alcohol, evite usar agentes de limpieza que contengan químicos corrosivos.









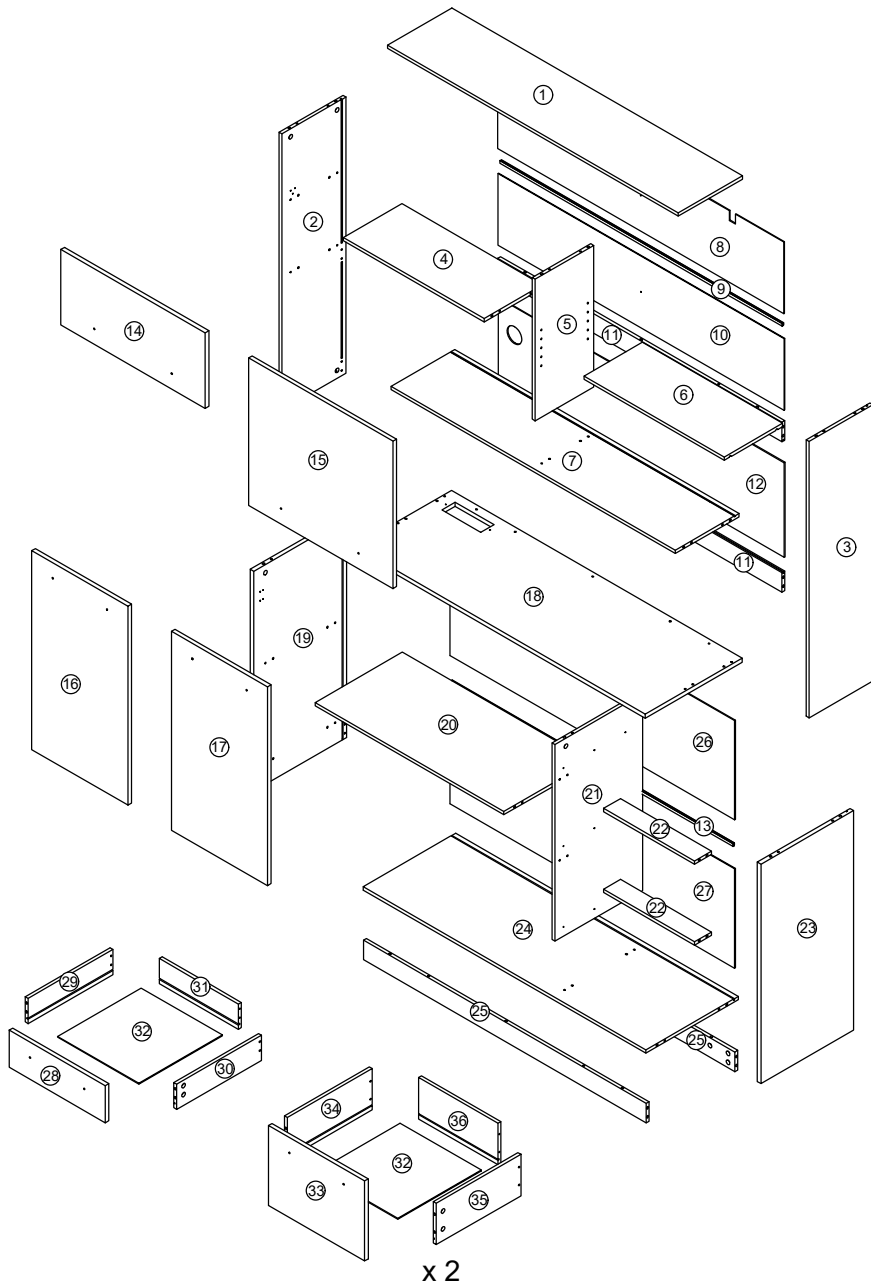

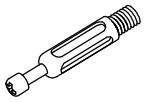

Advertencia: Este producto está equipado con un dispositivo antivuelco. Asegúrese de instalar este dispositivo para evitar lesiones innecesarias causadas por vuelcos.

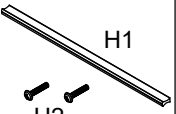
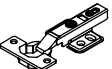

DE
Warnung: Die maximale Belastbarkeit dieses Möbels beträgt: 45 kg, bitte nicht überlasten!
EN
Warning: The maximum load-bearing capacity of this furniture is: 45 kg, please do not overload!
FR
Avertissement : La capacité de charge maximale de ce meuble est de : 45 kg, merci de ne pas surcharger !
IT
Attenzione: la capacità di carico massima di questo mobile è: 45 kg, non sovraccaricare!
ES
Advertencia: La capacidad máxima de carga de este mueble es: 45 kg, ¡no lo sobrecargue!

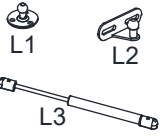
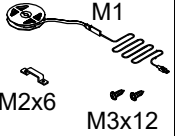
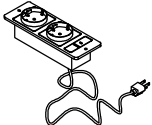
Importeur	Decobus Handel GmbH
Adresse	Innungsstraße 9, 21244 Buchholz, Deutschland
URL	https://www.decobusgroup.de
Hersteller	JIANGSU CHAONENG NEW MATERIALS TECHNOLOGY Co.,LTD.
Adresse	Guannan County Economic Development Zone, Lianyungang City (south of Provincial Highway 235)
Email/URL	lixinrui@jschaonengcl.com.cn
Hergestellt in	CHINA
	Decobus Handel GmbH Innungsstraße 9, 21244 Buchholz, Deutschland https://www.decobusgroup.de

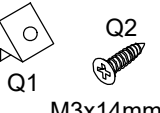
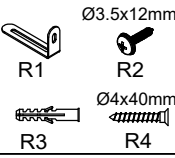

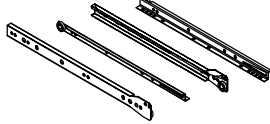
 Ø6 x 35 mm	 Ø15 x 9.5 mm	 Ø6 x 30 mm	 Ø5 x 40 mm	 Ø3.5x12mm	 Ø5x16mm	 G1 G2 M4 x 19 mm
A x 82	B x 82	C x 44	D x 14	E x 89	F x 4	G x 5
 H1 H2 M4 x 19 mm	 I	 J	 Ø3 x 14 mm	 L1 L2 L3	 M1 M2x6 M3x12	 N
H x 2	I x 6	J x 2	K x 4	L x 1	M x 1	N x 1
 Ø3.5x14mm	 Ø20mm	 Q1 Q2 M3x14mm	 R1 R2 R3 R4 Ø3.5x12mm Ø4x40mm	 S	 CL+CR+DL+DR	
O x 2	P x 82	Q x 28	R x 2	S x 6	CL+CR+DL+DR x 3	

USING CAM LOCK AND QUICKFIT

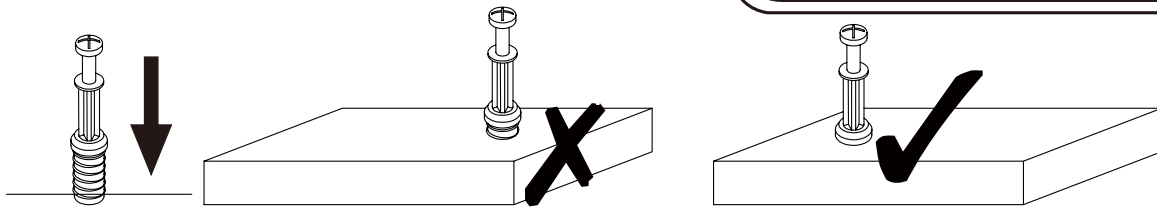

EN_QUICKFIT: Tighten quickfit until shoulder is flush with panel. Do not overtighten or undertighten.

FR_RACCORD RAPIDE: Faites serrer le raccord rapide jusqu'à ce que l'épaulement soit parfaitement encastré dans le panneau. Il ne faut ni trop serrer ni insuffisamment serrer.

ES_QUICKFIT: Apriete quickfit hasta que el hombro se descargue con el panel. NO lo sobreapriete ni lo apriete poco.

DE_QUICKFIT: Ziehen Sie den Quickfit fest, bis die Schulter mit der Platte bündig ist. Bitte nicht zu fest oder zu schwach anziehen.

IT_MONTAGGIO RAPIDO: Stringere il montaggio rapido fino a quando la spalla è a filo con il pannello, non stringere troppo o troppo poco.

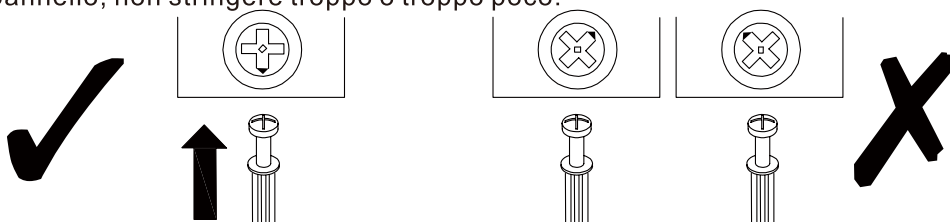

EN_CAM LOCK: When fitting cam lock, ensure starting position is correct before you insert connecting quickfit.

FR_SERRURE BATTEUSE: Avant d'insérer la serrure batteuse, veillez à la bonne orientation avant d'insérer le raccord rapide.

ES_CIERRE DE LA CÁMARA: Cuando instale el cierre de la cámara, asegúrese de que la posición de inicio es correcta antes de que inserte el quickfit conector.

DE_CAM-LOCK: Achten Sie bei der Montage des Cam-Locks auf die richtige Ausgangsposition, bevor Sie den Quickfit einsetzen.

IT_BLOCCAGGIO A CAMMA: Quando si monta il bloccaggio a camma, assicurarsi che la posizione iniziale sia corretta prima di inserire il montaggio rapido di collegamento.

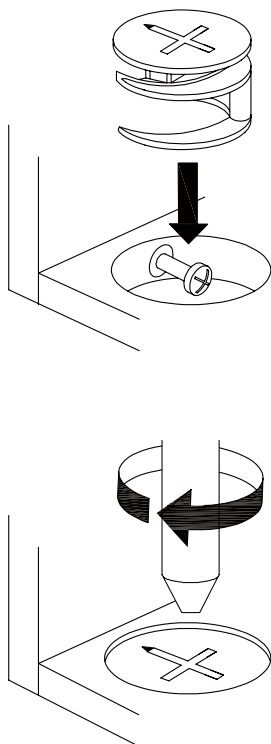

EN_Quickfit head should be in the centre of the cam lock when the two panels are joined.

Cam lock should be inserted before quickfit.

FR_Lorsque les deux panneaux sont assemblés, la tête du raccord rapide doit reposer au centre de la serrure batteuse. Il faut insérer la serrure batteuse avant le raccord rapide.

ES_El cabezal del quickfit debe estar en el centro del cierre de la cámara cuando se unan los dos paneles.

Se debe insertar el cierre de la cámara antes que el quickfit.

DE_Der Quickfit-Kopf sollte sich in der Mitte des Cam-Locks befinden, wenn die beiden Platten zusammengefügt sind.

Der Cam-Lock sollte vor dem Quickfit eingesetzt werden.

IT_La testa del montaggio rapido deve trovarsi al centro del bloccaggio a camma quando i due pannelli sono uniti.

Il Bloccaggio a Camma deve essere inserito prima del montaggio rapido.

EN_Turn cam lock clockwise to tighten.

FR_Faites tourner la serrure batteuse dans le sens des aiguilles d'une montre pour la resserrer.

ES_Gire el cierre de la cámara en sentido horario para apretarlo.

DE_Drehen Sie den Cam-Lock im Uhrzeigersinn, um ihn festzuziehen.

IT_Ruotare il bloccaggio a camma in senso orario per stringere.

EN It may be necessary to adjust the hinges so that the doors align. Use the instructions below as a guide.

FR Il est parfois nécessaire d'ajuster les charnières pour un meilleur alignement des portes. Servez-vous des instructions ci-dessous comme guide.

ES Puede que sea necesario ajustar los quicios de forma que se alineen las puertas. Use las instrucciones que aparecen debajo como guía.

DE Möglicherweise müssen Sie die Scharniere so einstellen, dass die Türen ausgerichtet sind. Verwenden Sie die nachstehenden Anweisungen als Leitfaden.

IT Potrebbe essere necessario regolare le cerniere in modo che le porte siano allineate. Per fare ciò attenersi alle istruzioni sottostanti.

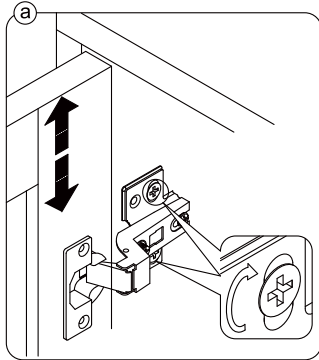

EN To adjust the door vertically loosen the screw as shown and move up and down as needed.

FR Si vous souhaitez régler la porte **verticalement**, desserrez la vis comme indiqué et déplacez la porte de haut en bas selon les besoins.

ES Para ajustar la puerta **verticalmente** afloje el tornillo tal y como se muestra y muévelo hacia arriba o hacia abajo según sea necesario.

DE Um die Tür **vertikal** auszurichten, lösen Sie die Schraube wie abgebildet und bewegen Sie sie nach Bedarf nach oben oder nach unten.

IT Per allineare la porta **verticalmente** allentare la vite come mostrato e spostarla in alto o in basso secondo necessità.

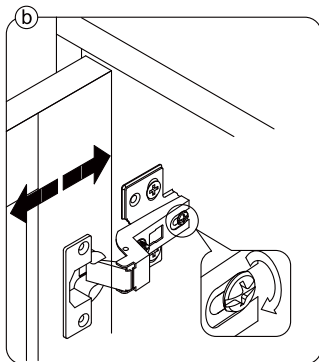

EN To adjust the gap from the door to the main frame turn the screw clockwise or anti-clockwise as needed.

FR Si vous souhaitez ajuster l'**écart** entre la porte et le cadre principal, tournez la vis dans le sens des aiguilles d'une montre ou dans le sens inverse, si nécessaire.

ES Para ajustar el **espacio** desde la puerta al marco principal, gire el tornillo en sentido horario o antihorario, según se necesite.

DE Um den **Abstand** von der Tür zum Hauptrahmen auszurichten, drehen Sie die Schraube je nach Bedarf im oder gegen den Uhrzeigersinn.

IT Per regolare lo **spazio** tra la porta e il telaio principale, avvitare o svitare la vite secondo necessità.

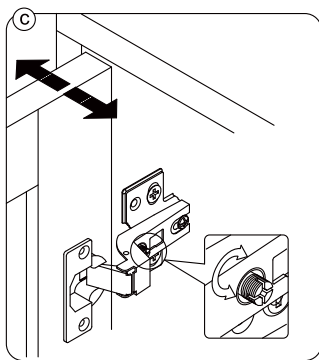

EN To adjust the door laterally adjust the screw as shown by turning clockwise or anti-clockwise.

FR Si vous souhaitez ajuster la porte **latéralement**, ajustez la vis comme indiqué en tournant dans le sens des aiguilles d'une montre ou dans le sens inverse des aiguilles d'une montre.

ES Para ajustar la puerta **lateralmente** ajuste el tornillo tal y como se muestra girándolo en sentido horario y antihorario.

DE Um die Tür **seitlich** auszurichten, stellen Sie bitte die Schraube wie abgebildet durch Drehen im oder gegen den Uhrzeigersinn ein.

IT Per allineare la porta **lateralmente** regolare la vite come mostrato, avvitandola o svitandola.

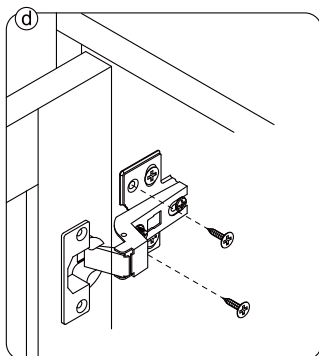

EN Please fix other screws

FR Merci de serrer les autres vis.

ES Fije los demás tornillos

DE Befestigen Sie bitte die anderen Schrauben

IT Fissare le altre viti

BOX 1-3	SKU: N634P456927
②	988*264*12mm=1pc
③	988*264*12mm=1pc
⑯	711*397*15mm=1pc
⑰	711*397*15mm=1pc
⑲	785*383*15mm=1pc
⑳	779*360*12mm=1pc
㉑	703*362*12mm=1pc
㉓	785*383*15mm=1pc

BOX 2-3	SKU: N634P456928
①	1200*265*12mm=1pc
⑦	1173*263*12mm=1pc
⑧	1181*256*3mm=1pc
⑨	1171mm=1pc
⑩	1181*256*3mm=1pc
⑪	1173*70*12mm=2pcs
⑫	1181*338*3mm=1pc
⑬	1165mm=1pc
⑱	1200*400*15mm=1pc
㉔	1167*382*12mm=1pc
㉕	1167*70*12mm=2pcs

⑳	1175*355*3mm=1pc
㉗	1175*355*3mm=1pc

BOX 3-3	SKU: N634P456929
④	580*241*12mm=1pc
⑤	506*242*12mm=1pc
⑥	579*241*12mm=1pc
⑭	596*270*15mm=1pc
⑮	596*527*15mm=1pc
㉒	376*70*12mm=2pcs
㉘	397*133*15mm=1pc
㉙	350*90*12mm=1pc
⑳	350*90*12mm=1pc
㉚	327*90*12mm=1pc
㉛	335*345*3mm=3pcs
㉜	397*286*15mm=2pcs
㉝	350*148*12mm=2pcs
㉞	350*148*12mm=2pcs
㉟	327*148*12mm=2pcs



Hardware Kit

1.

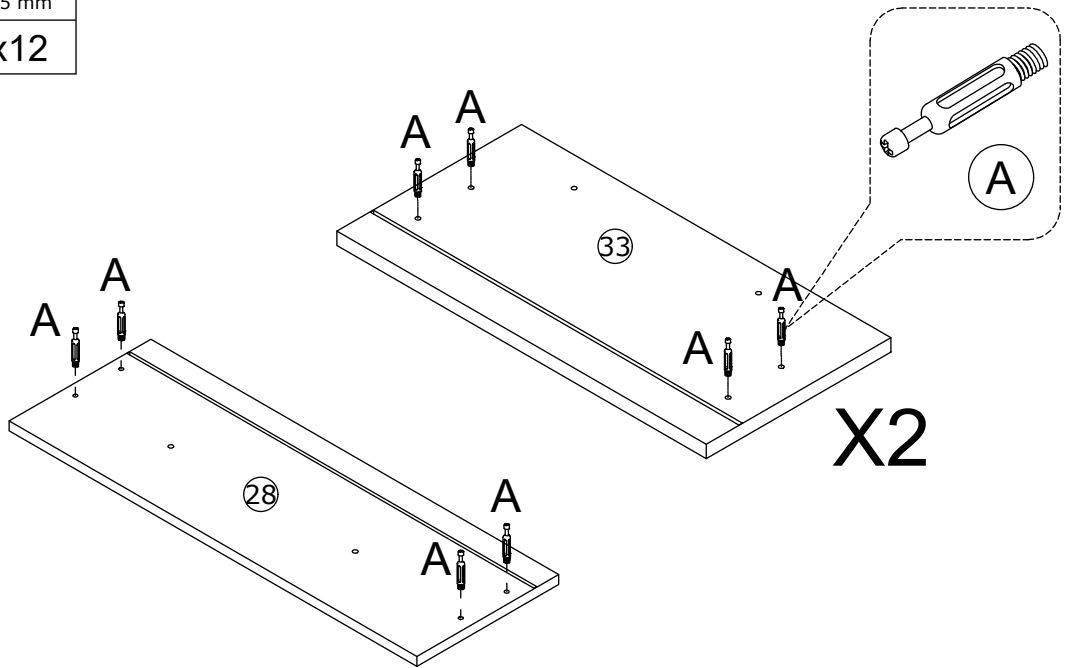
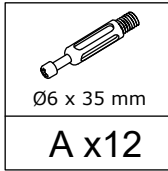

2.

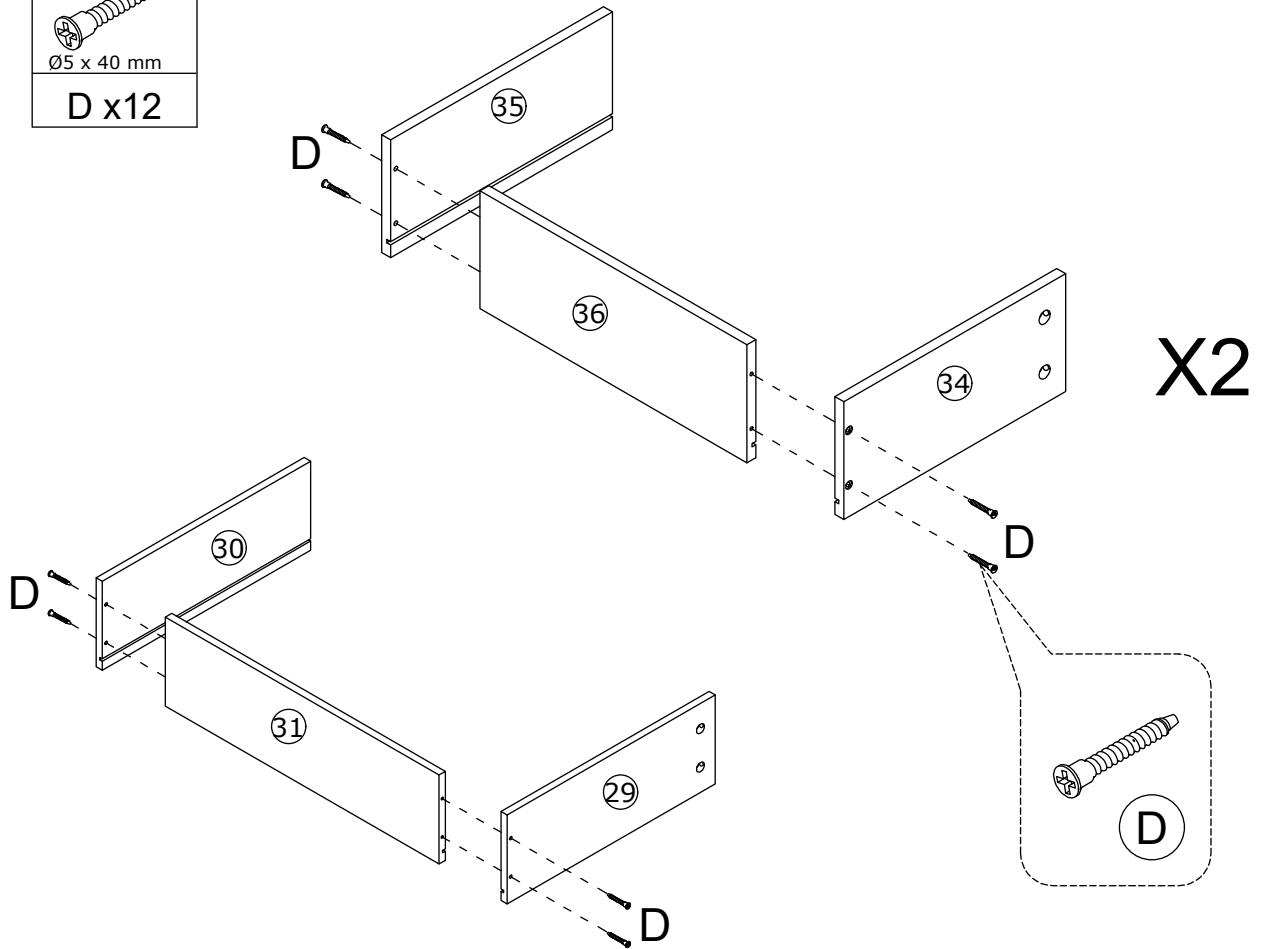
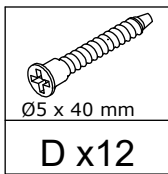

3.

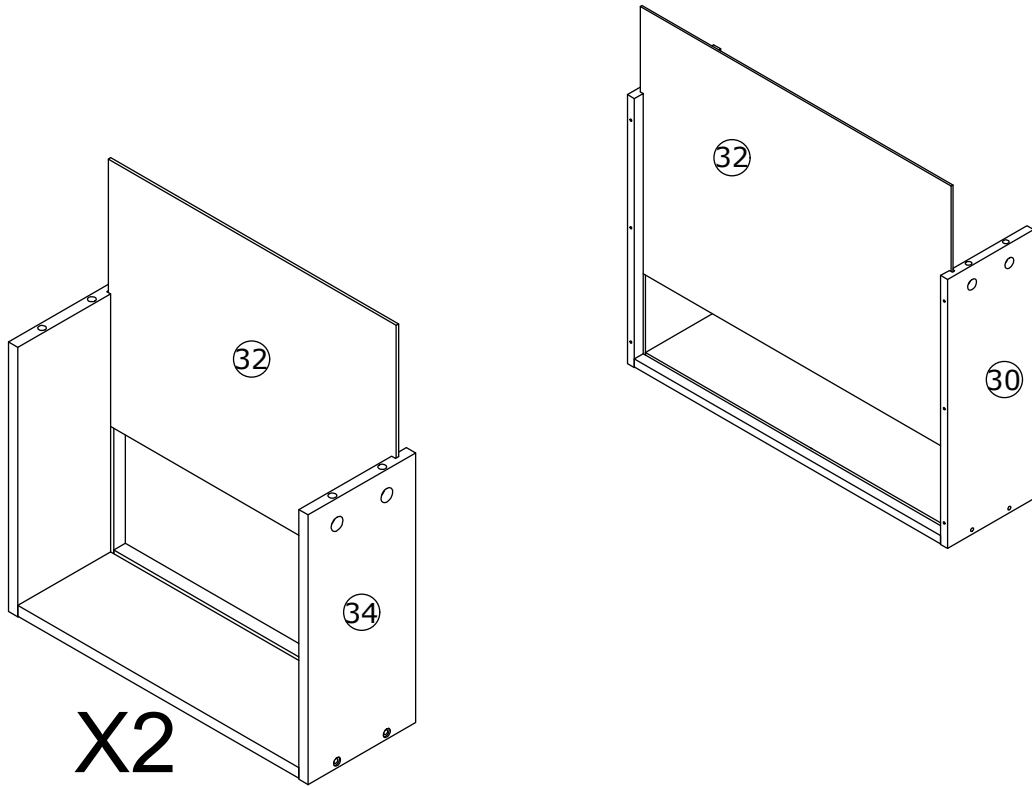

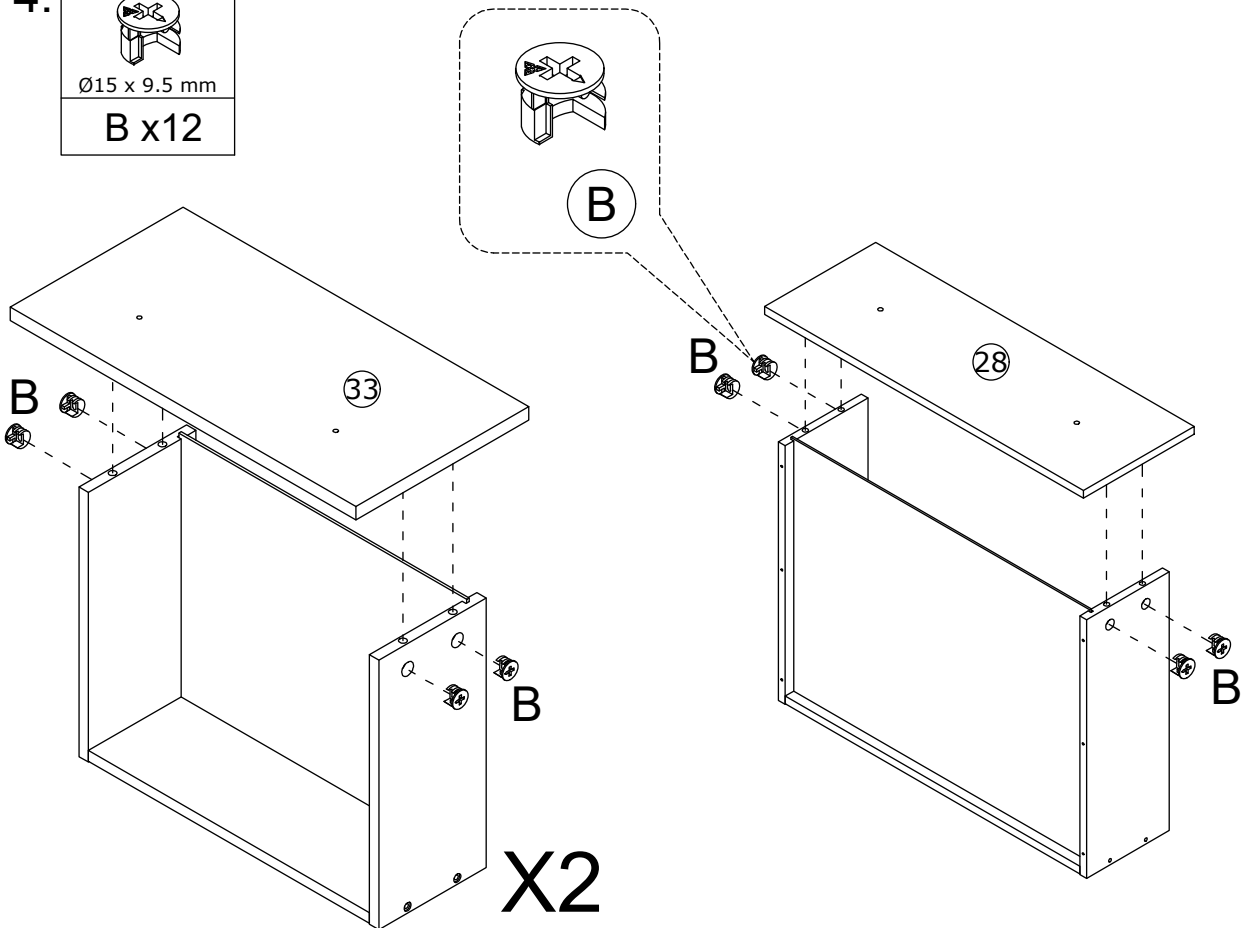
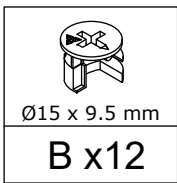

4.

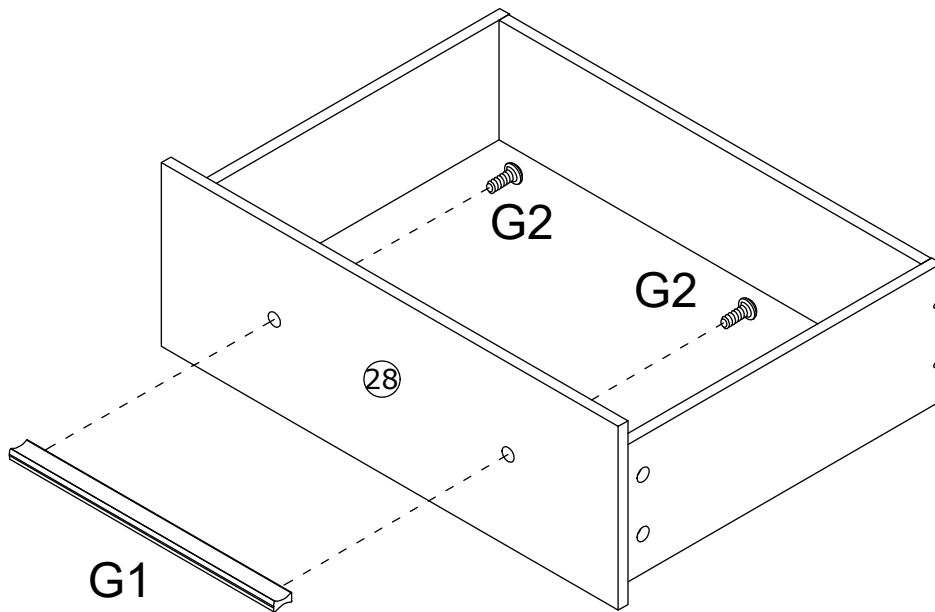
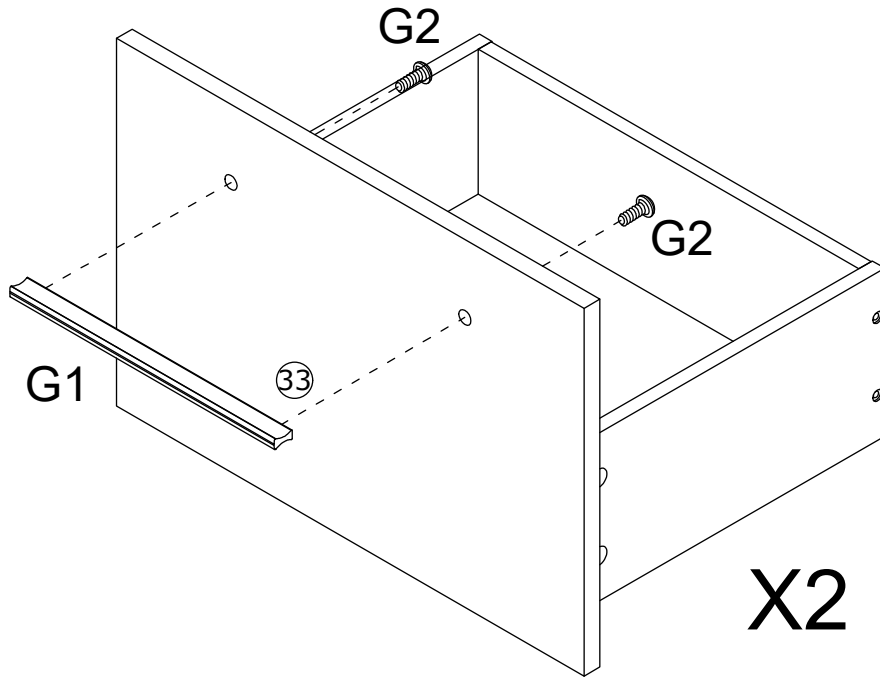
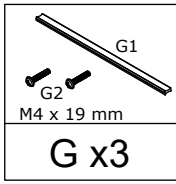

5.



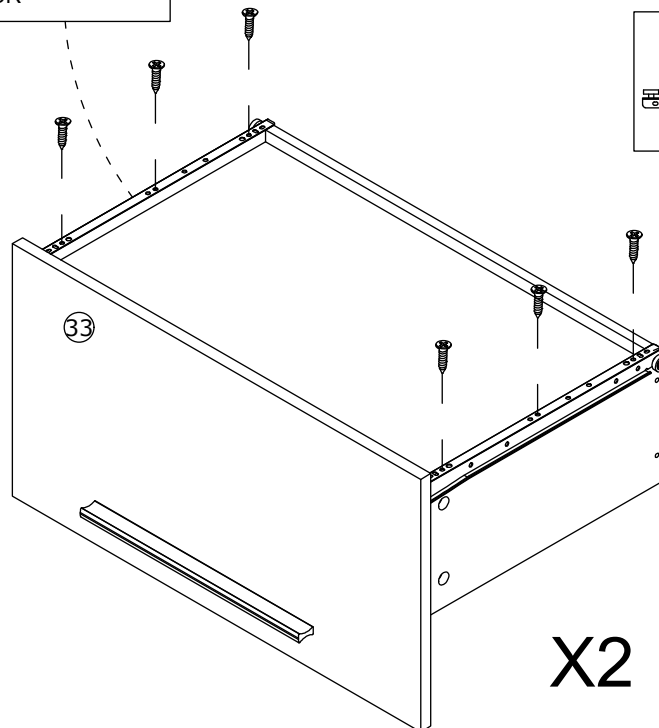
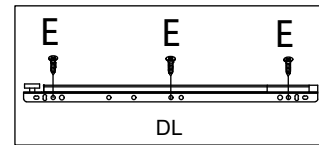
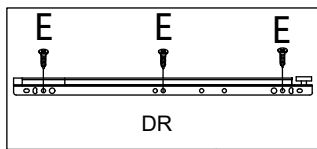
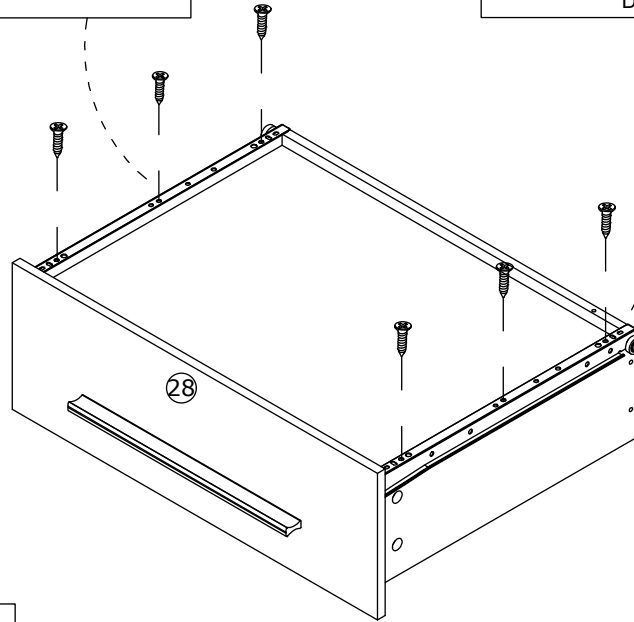
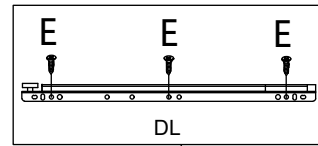
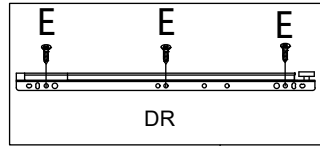

6.

 Ø3.5x12mm	
E x18	DL+DR x3

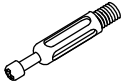

X2

7.

 Ø6 x 35 mm	 M1 M2x6 M3x12
A x7	M x1

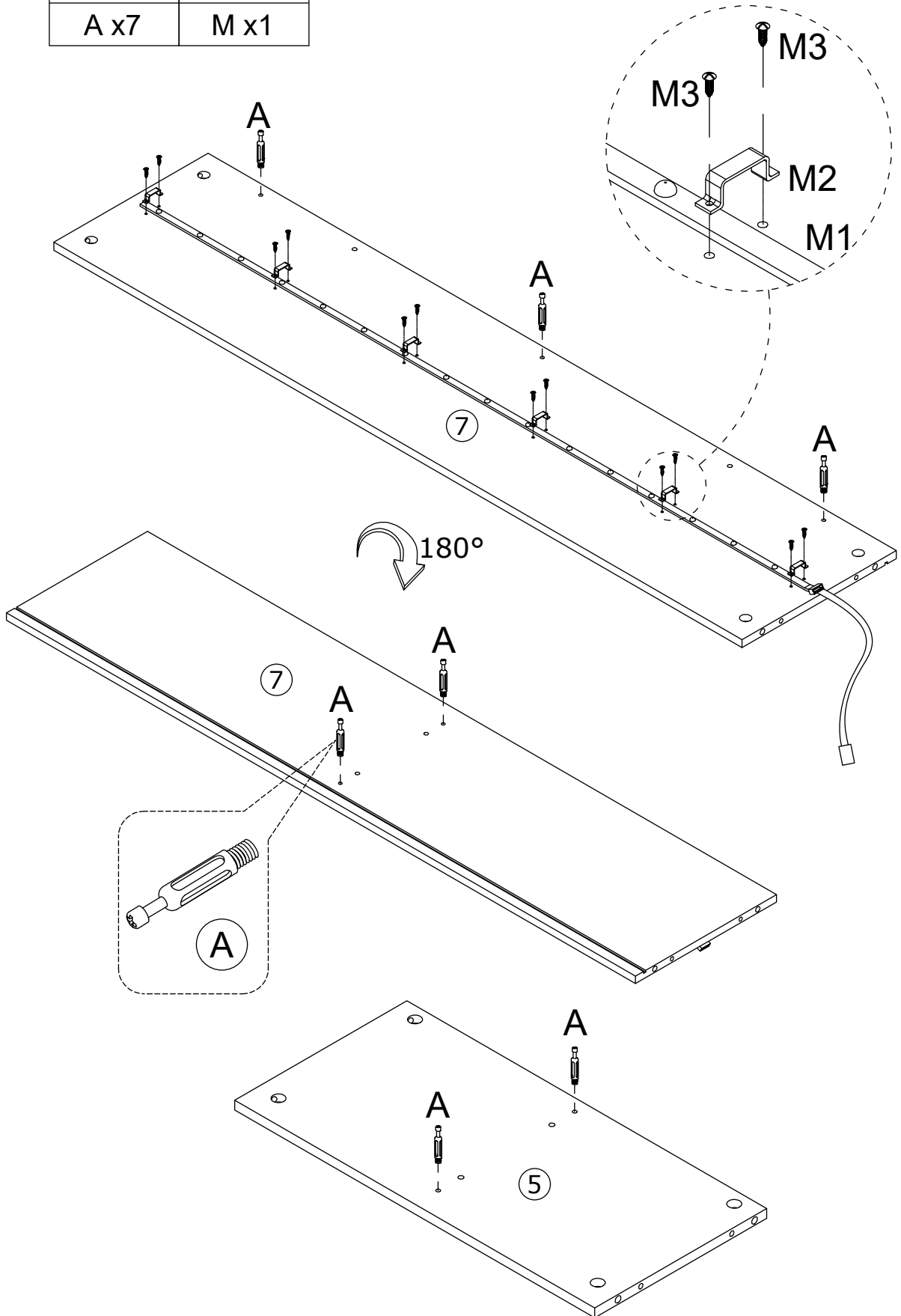

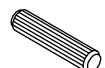

8.

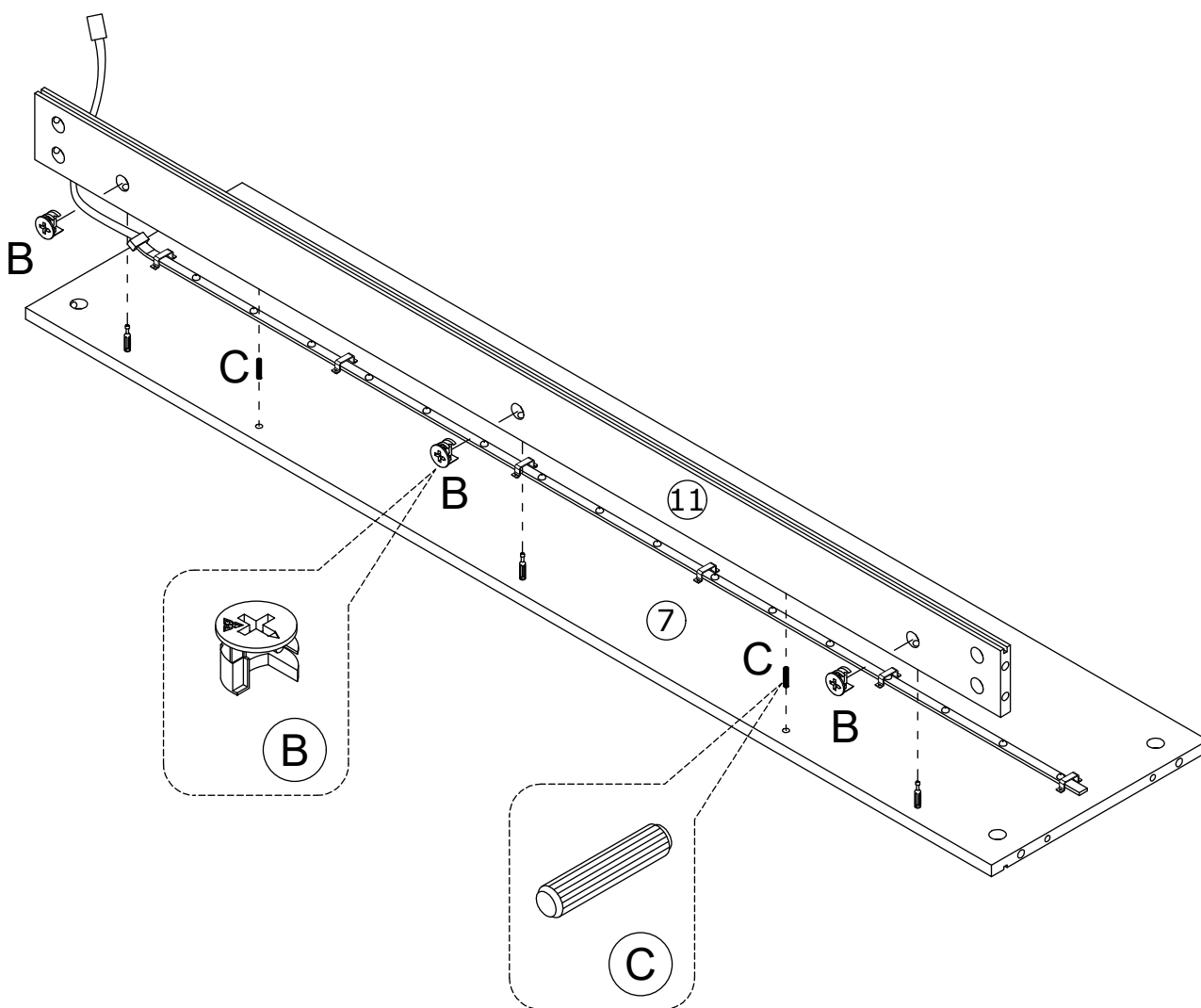
	
Ø15 x 9.5 mm	Ø6 x 30 mm
B x3	C x2



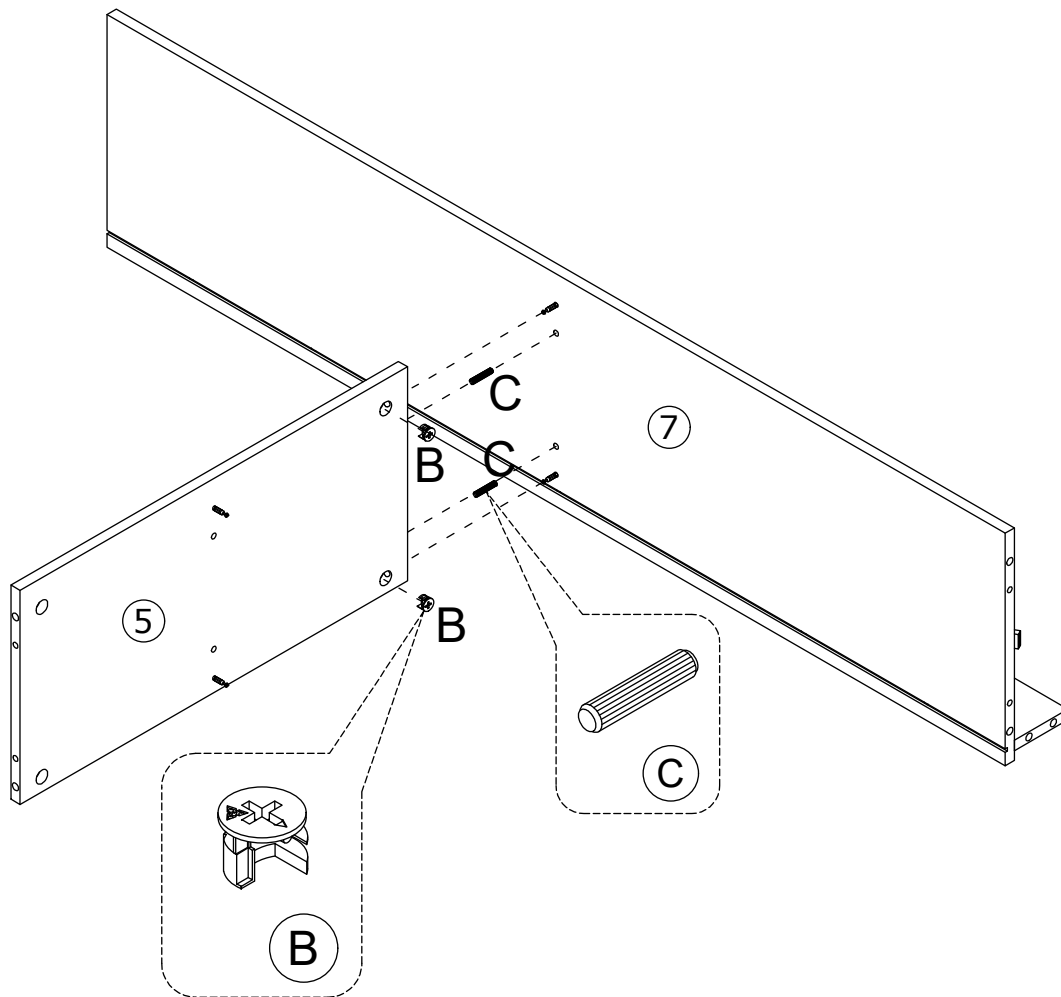

9.

	
Ø15 x 9.5 mm	Ø6 x 30 mm
B x2	C x2



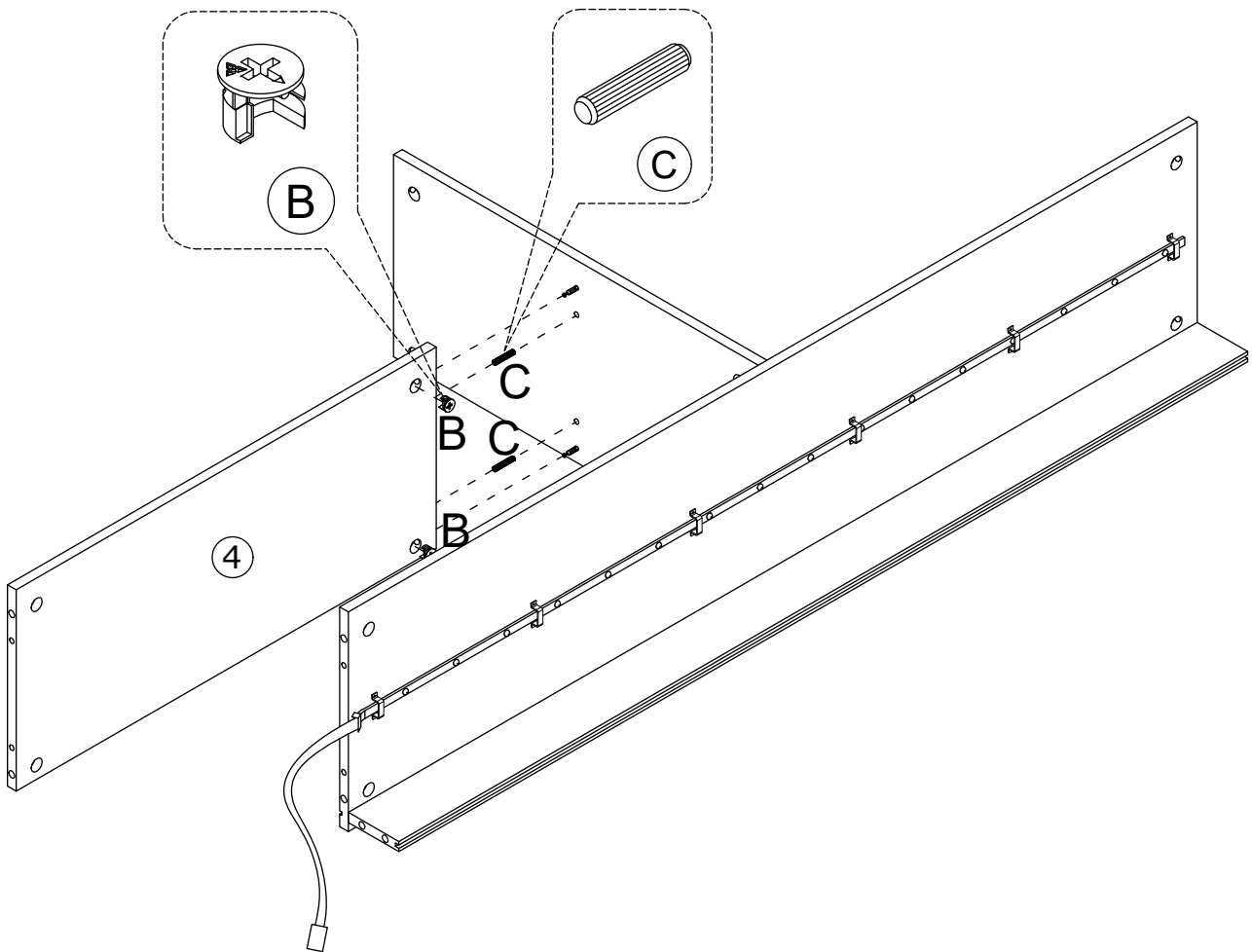

10.

 Ø15 x 9.5 mm	 Ø6 x 30 mm
B x2	C x2



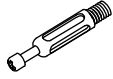

11.

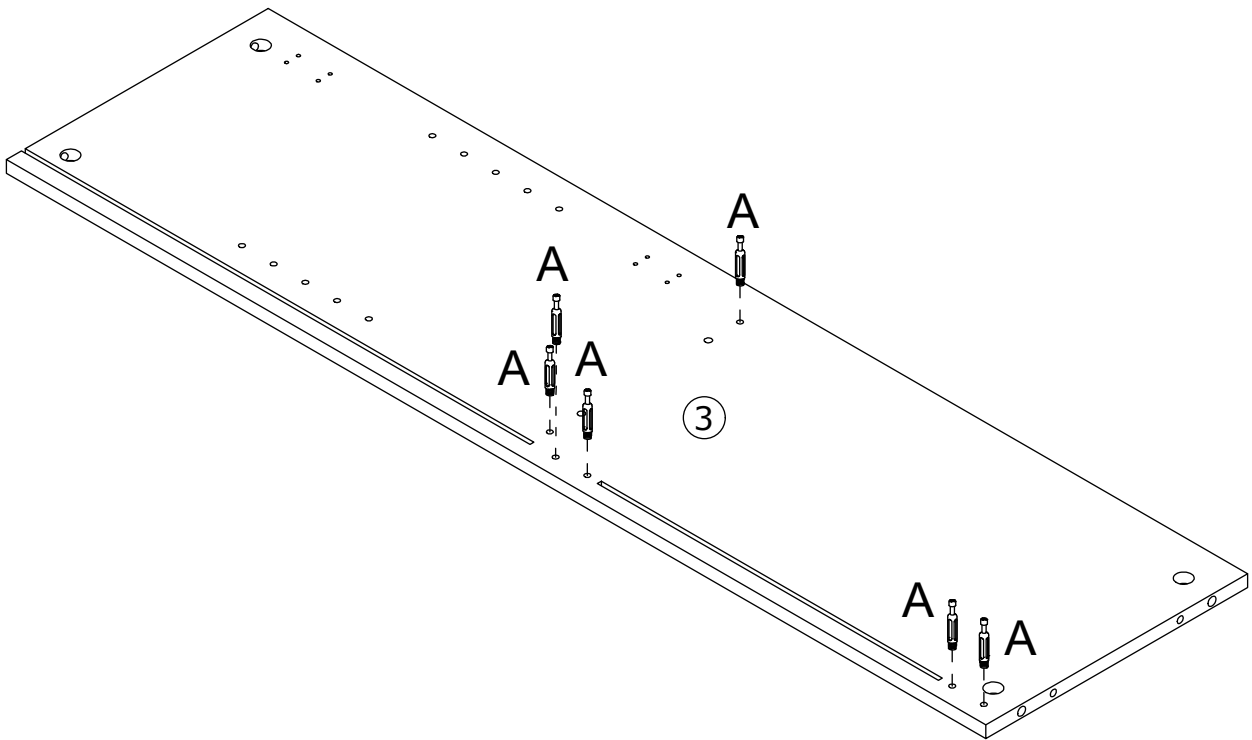
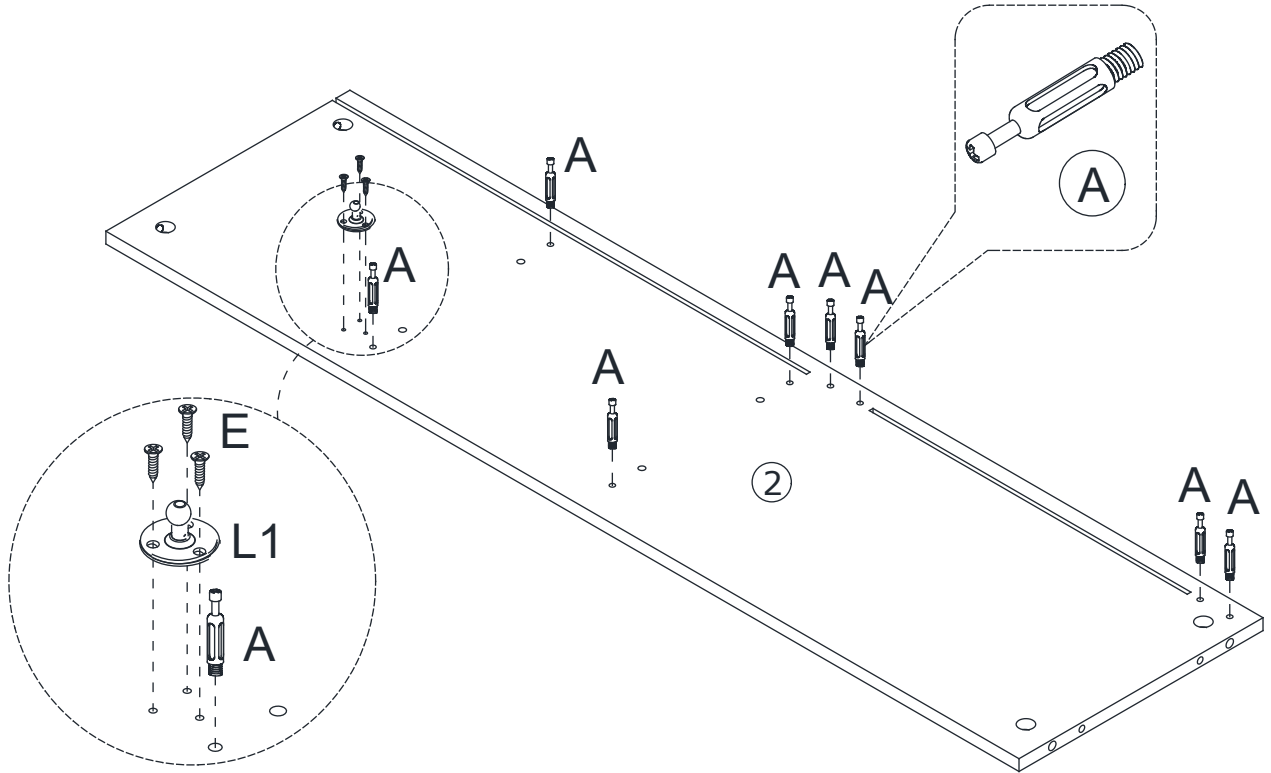
 Ø6 x 35 mm	 Ø3.5x12mm	 L1
A x14	E x3	L x1



12.

	
Ø15 x 9.5 mm	Ø6 x 30 mm
B x4	C x4

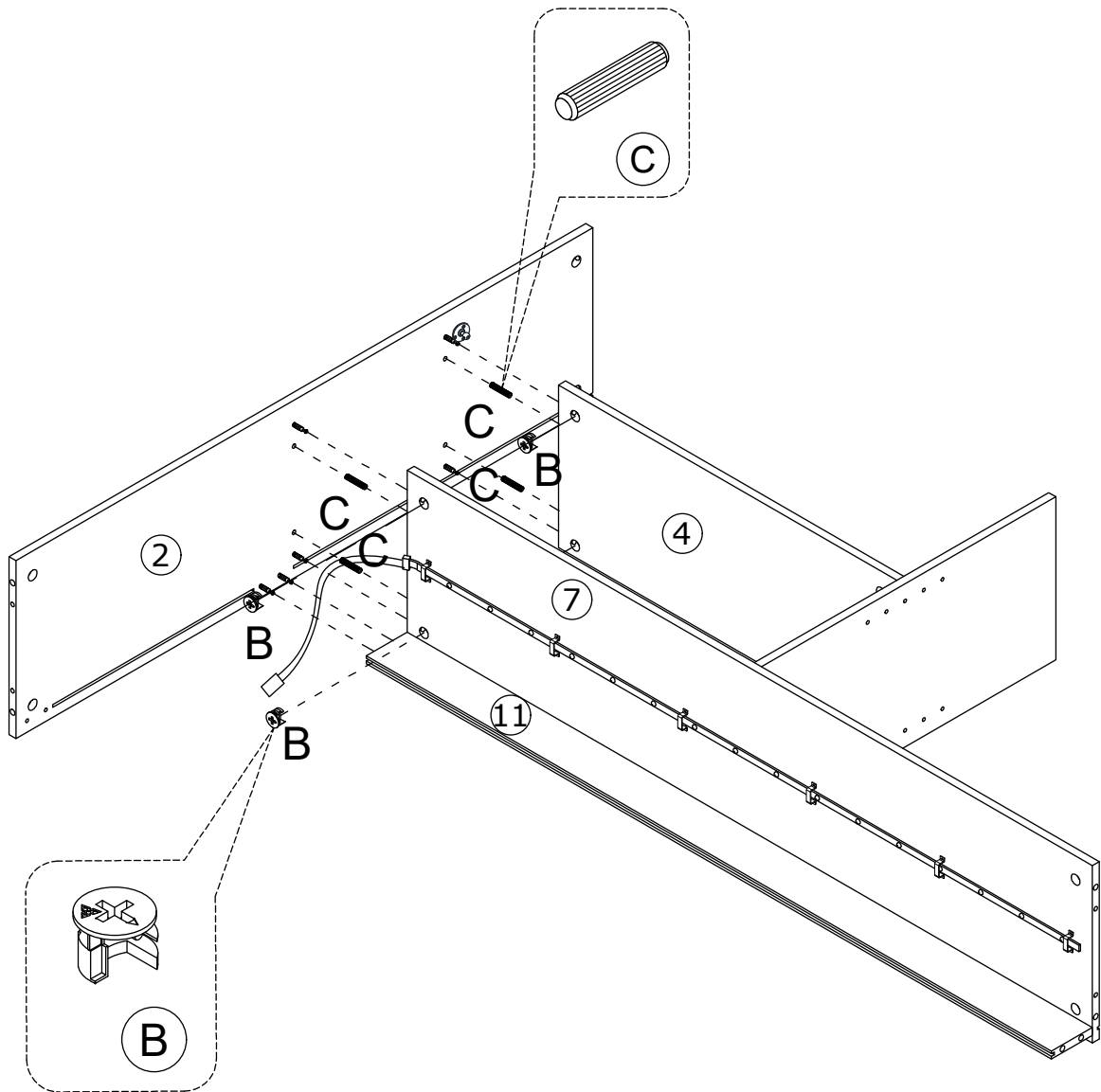

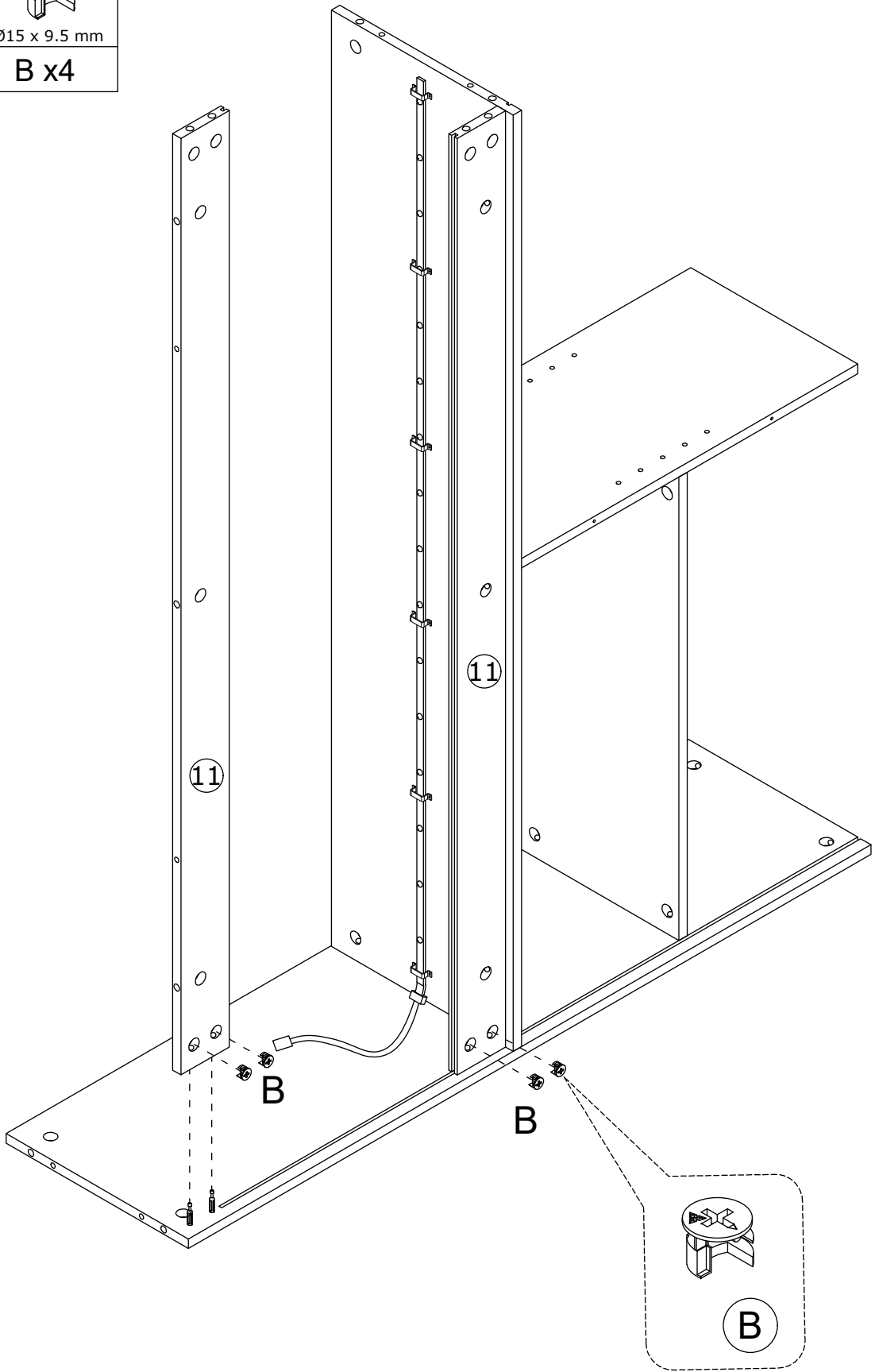
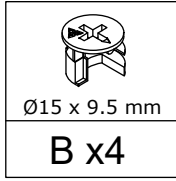

13.

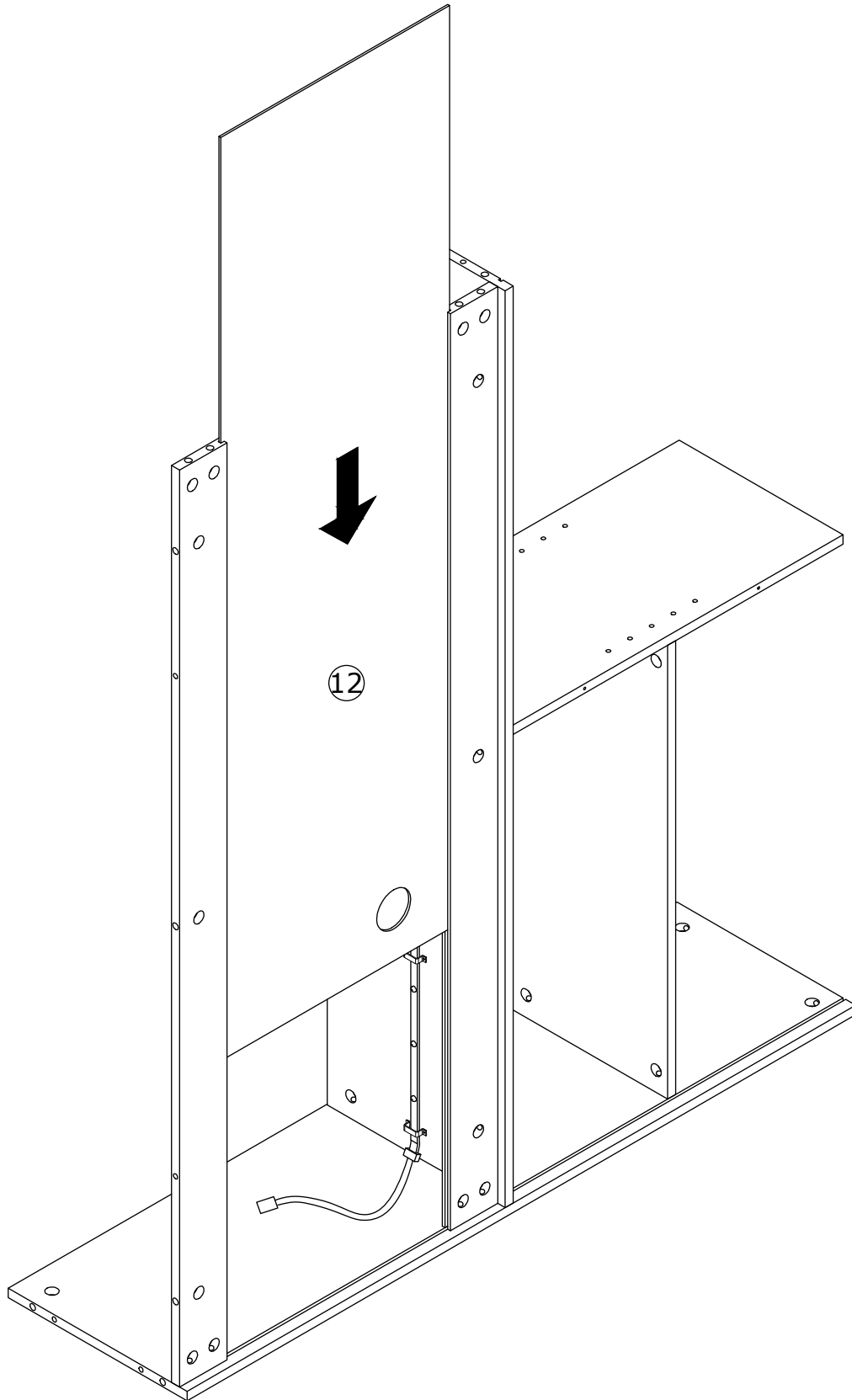

14.



15.

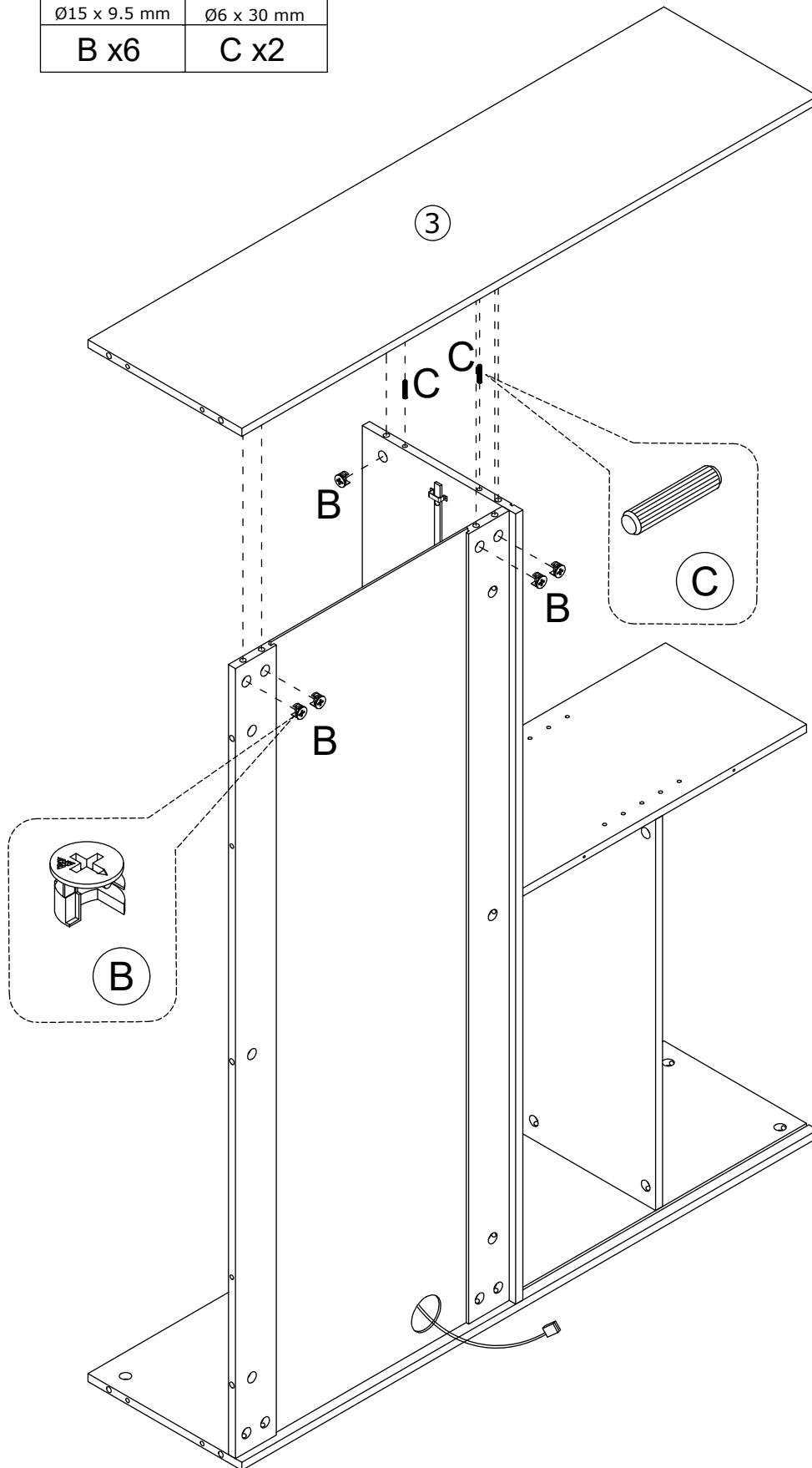

	
Ø15 x 9.5 mm	Ø6 x 30 mm
B x6	C x2

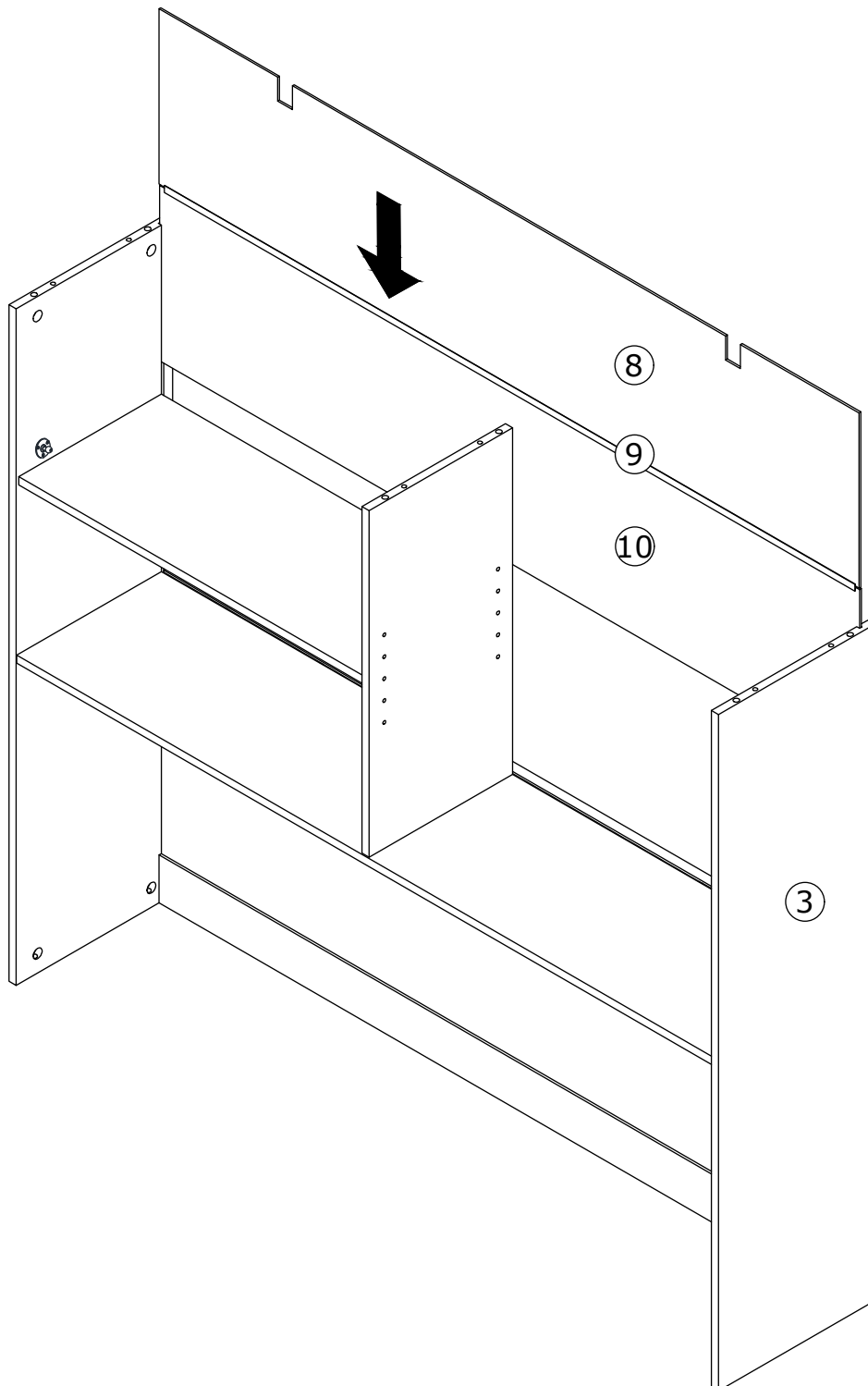

16.

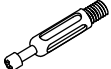

17.

 Ø6 x 35 mm	 R1	 R2
A x6	R x2	

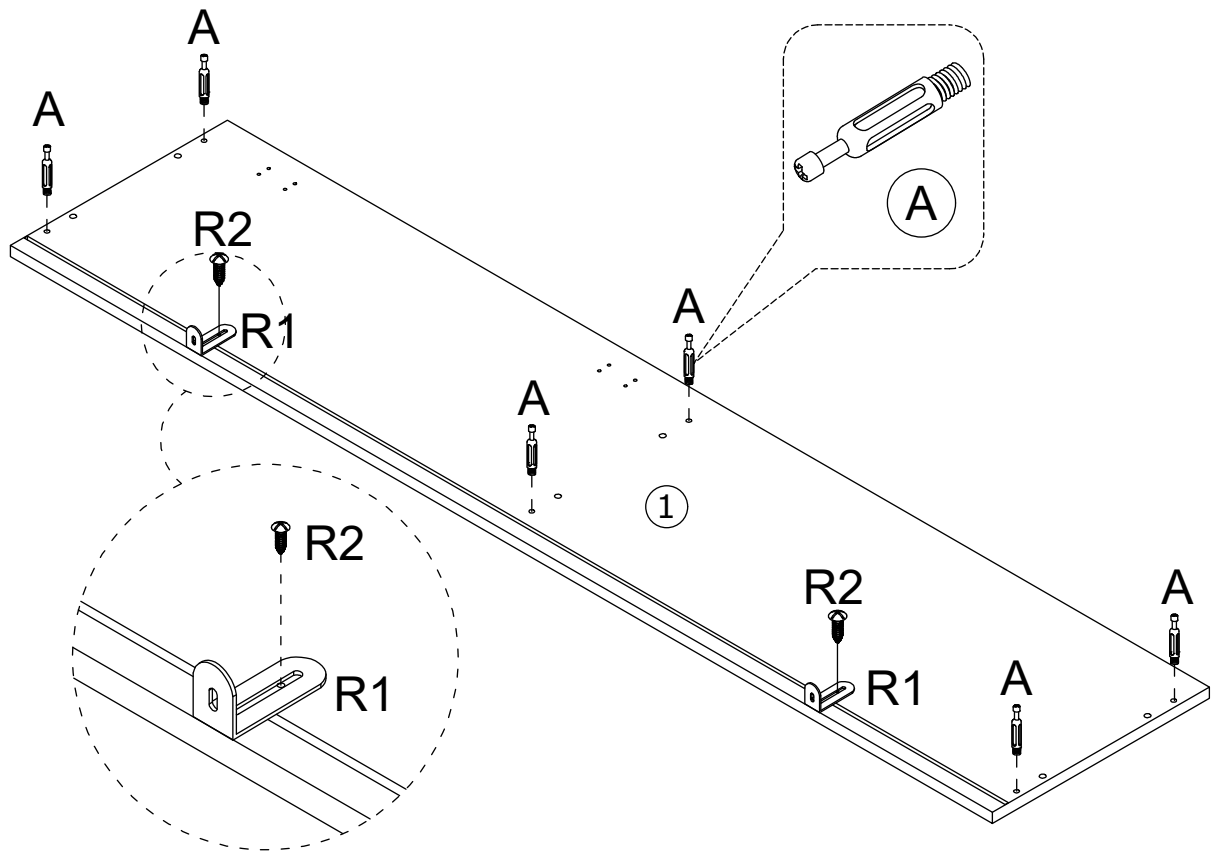

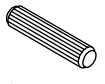

18.

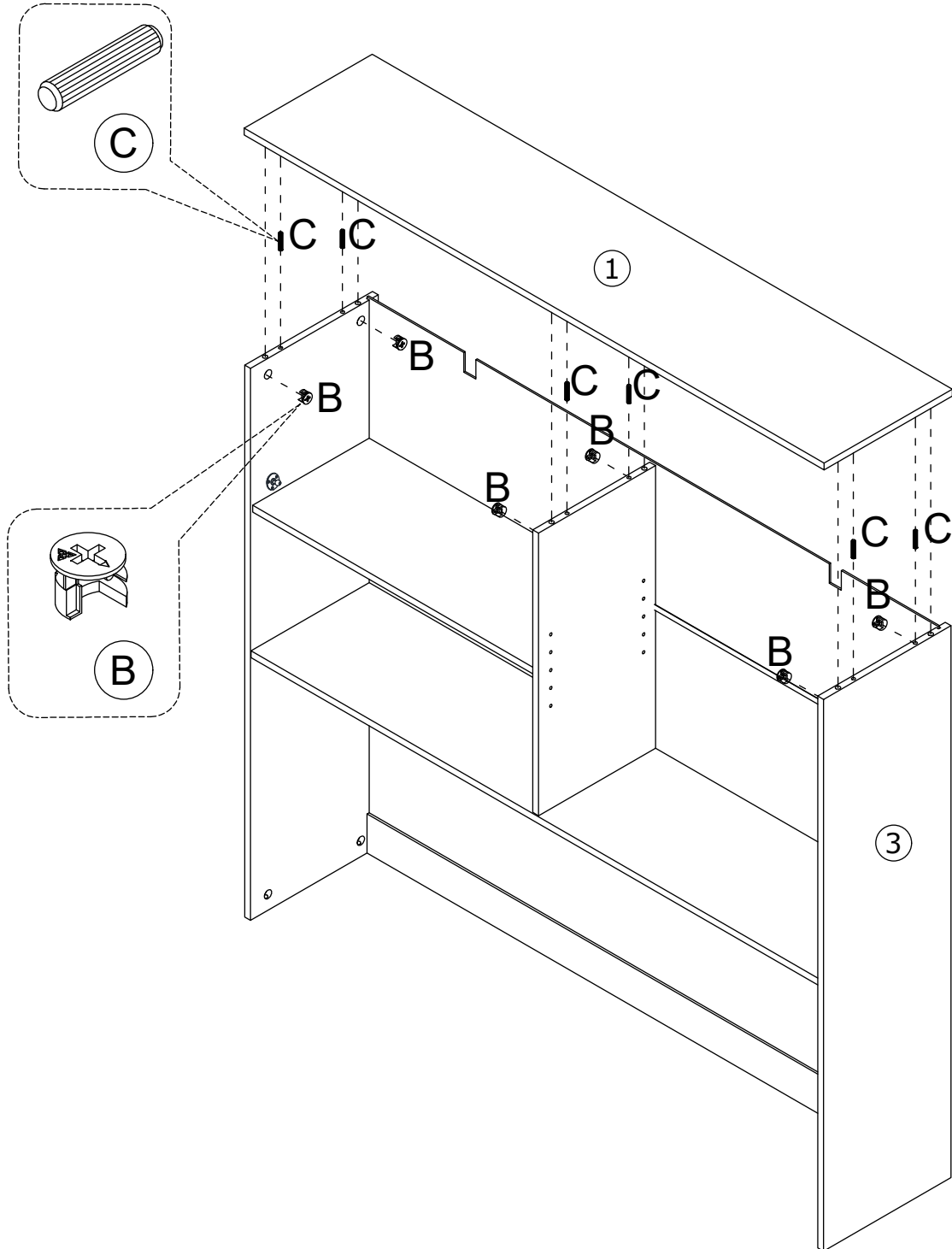
 Ø15 x 9.5 mm B x6	 Ø6 x 30 mm C x6
--	--

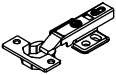

19.

 Ø3.5x12mm		 L2
E x6	I x2	L x1

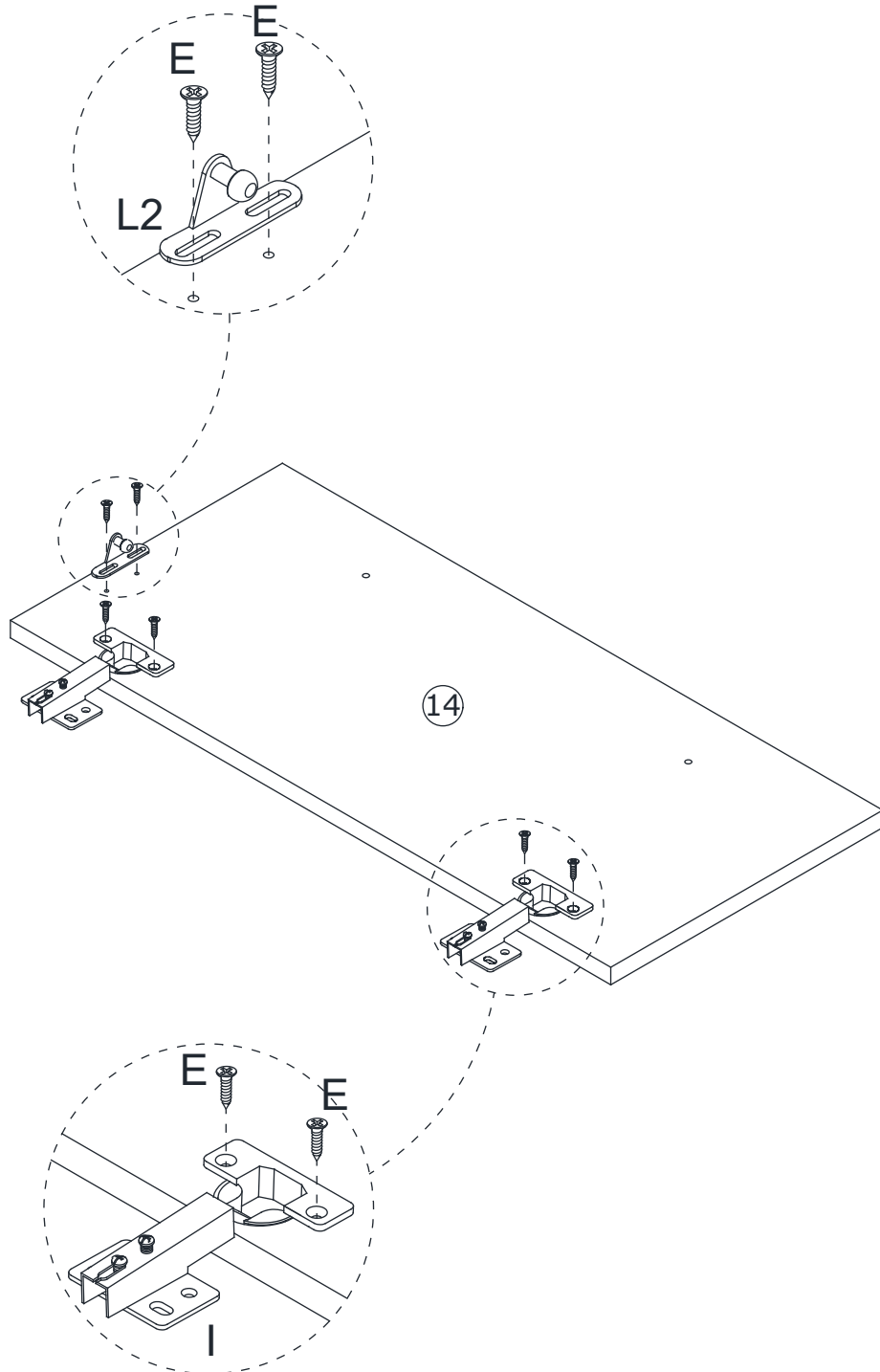

20.

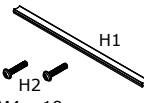
 Ø3.5x12mm	 H1 H2 M4 x 19 mm
E x8	H x1

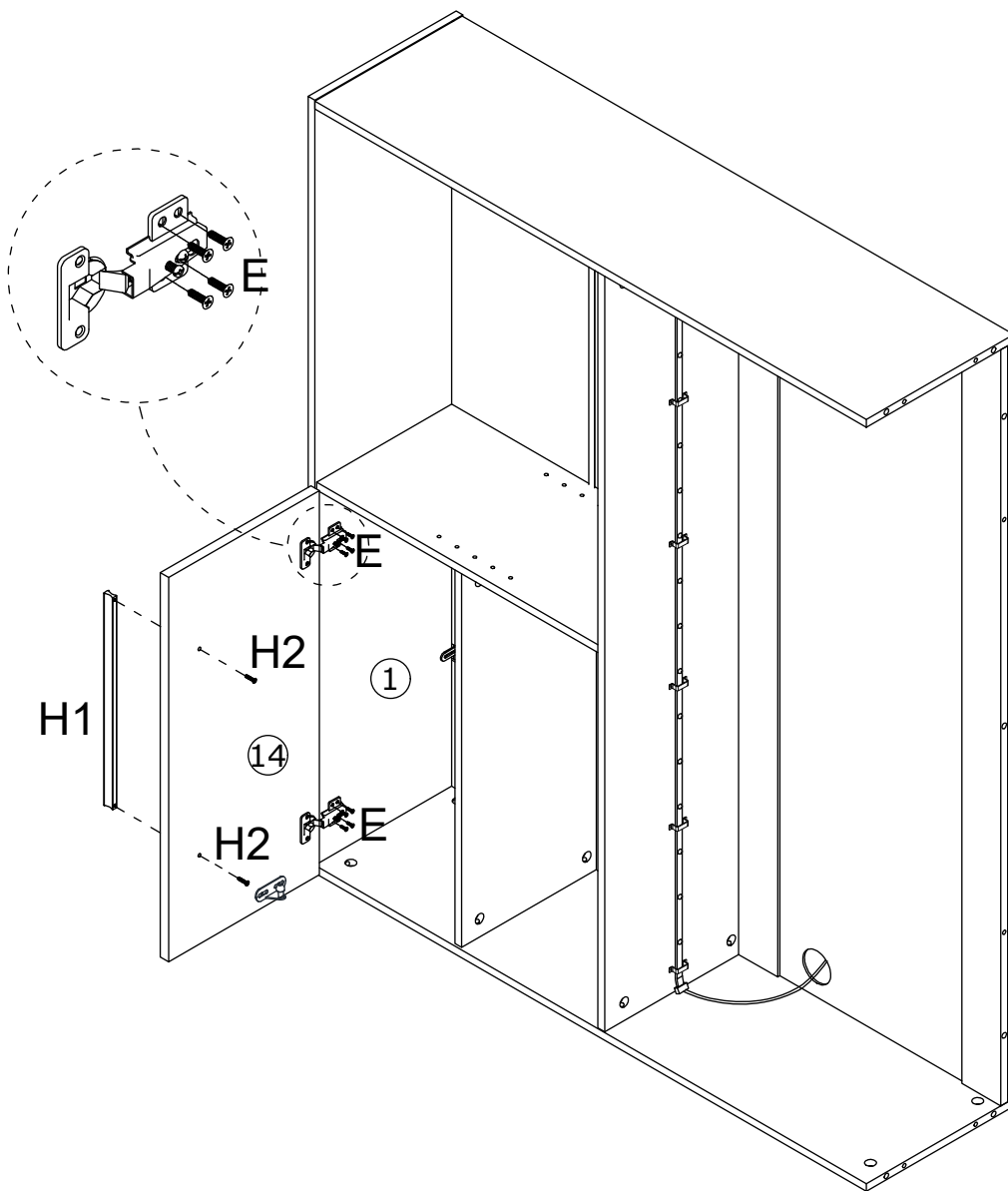

21.

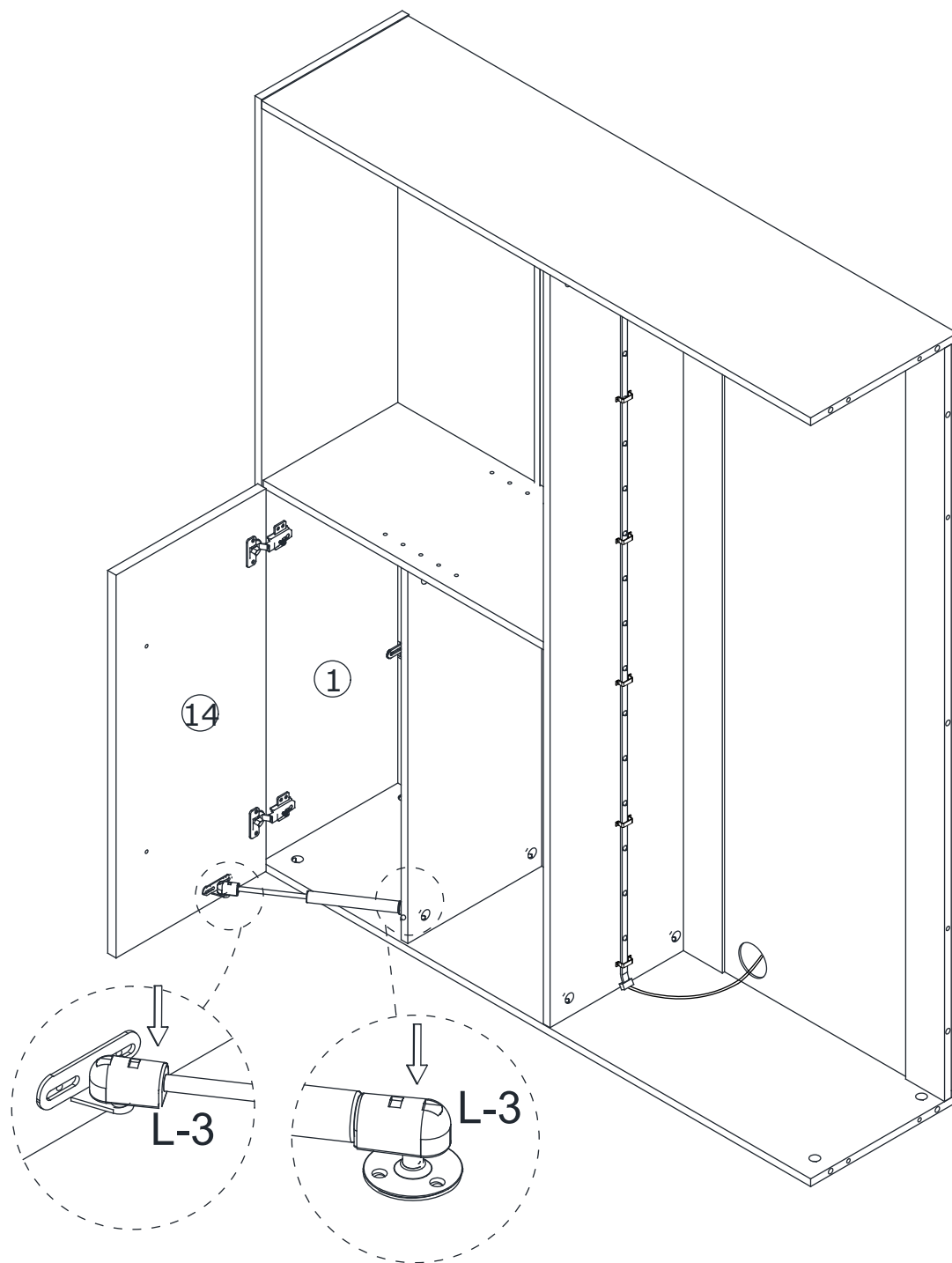
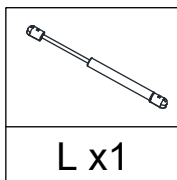

22.

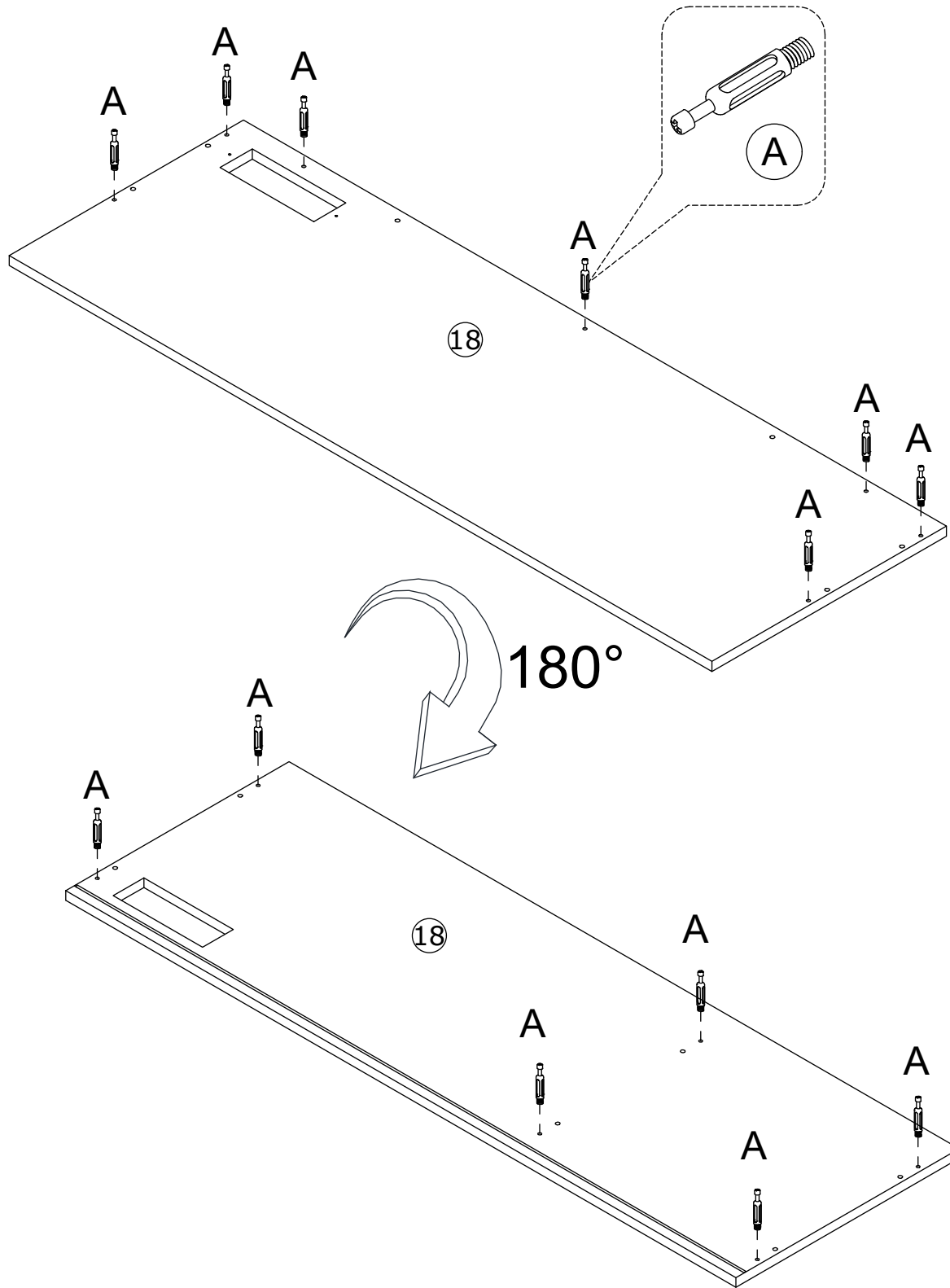
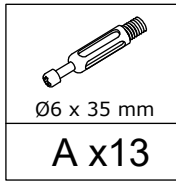

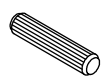

23.

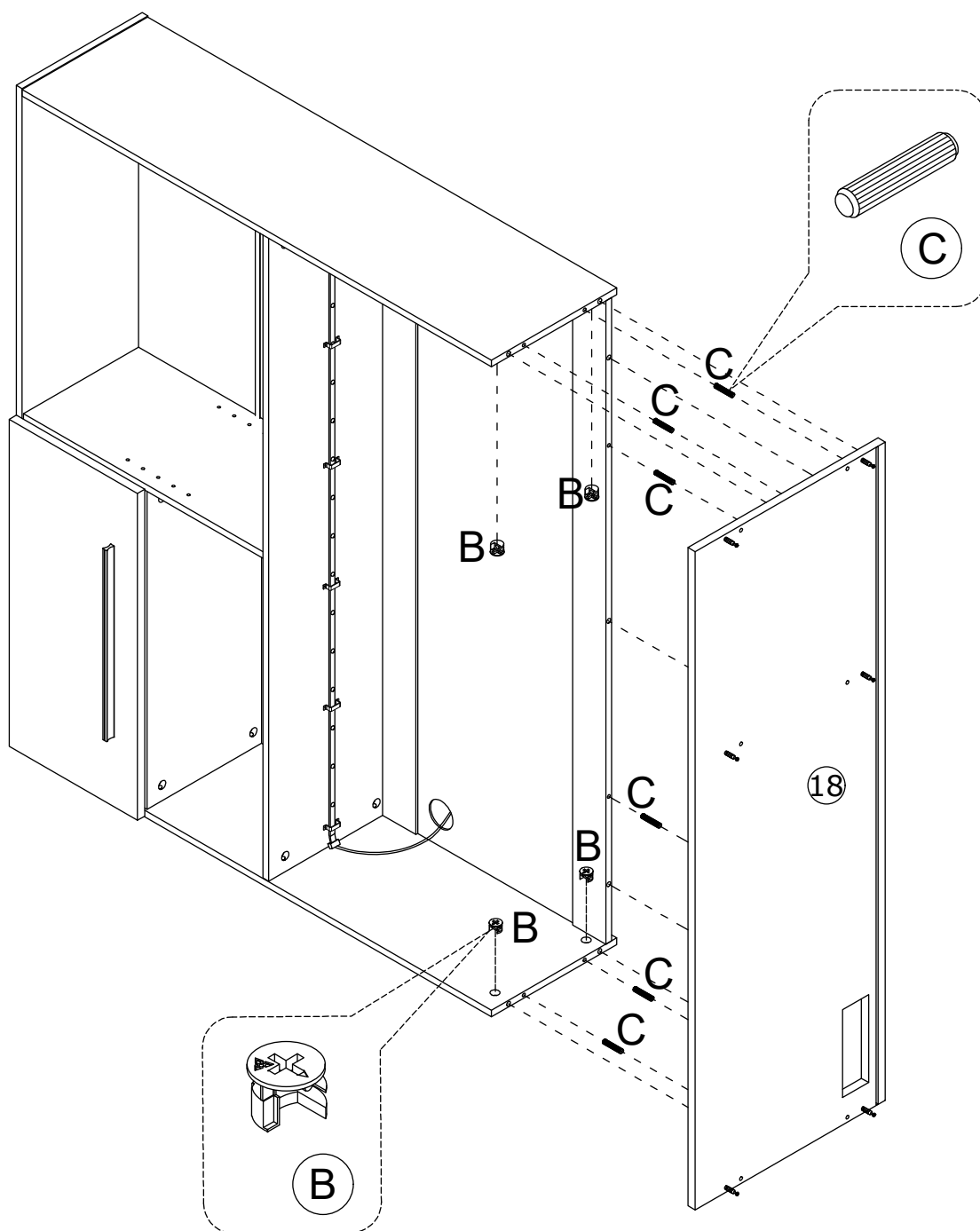
 Ø15 x 9.5 mm	 Ø6 x 30 mm
B x4	C x6



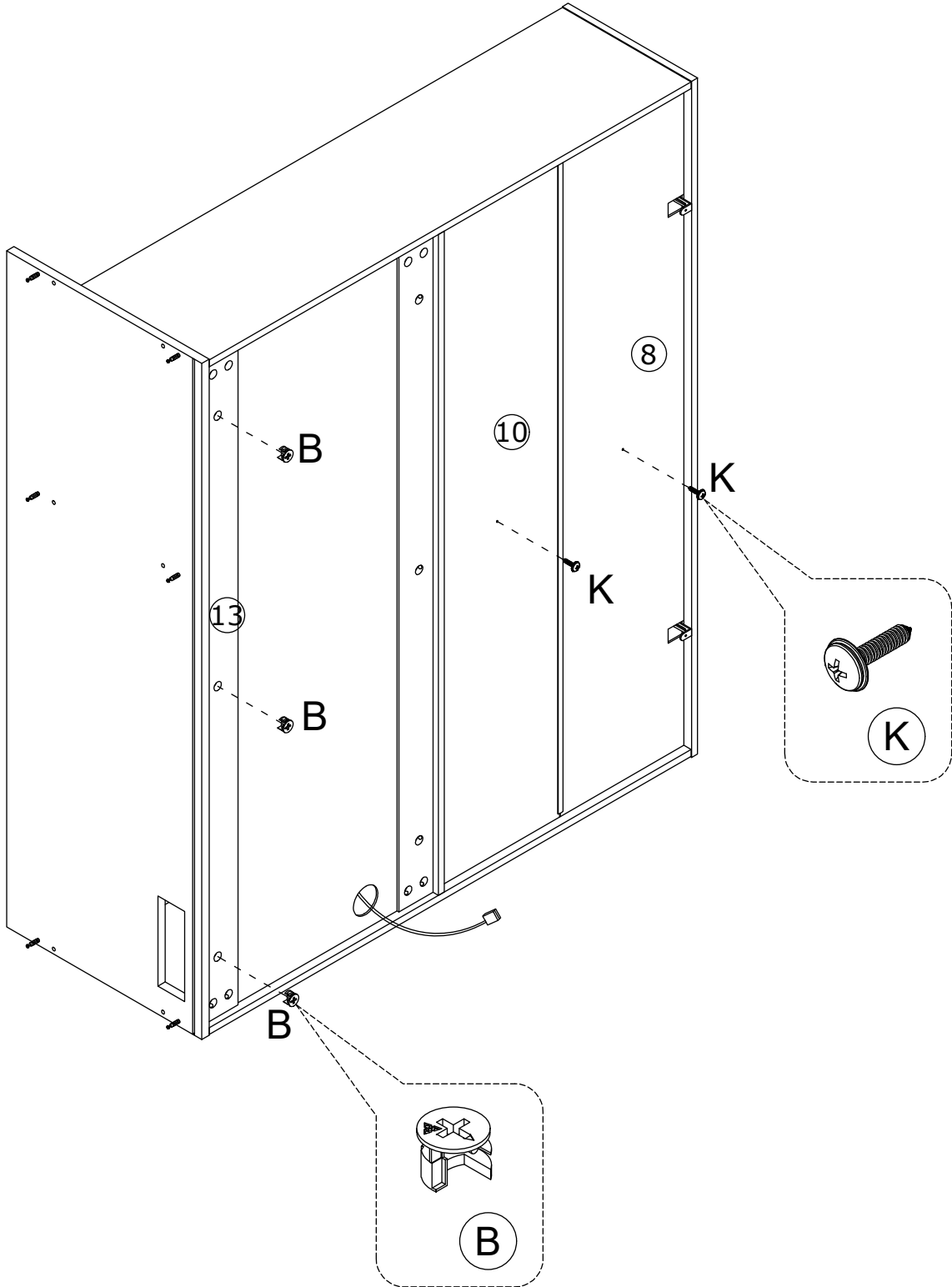

24.

 Ø15 x 9.5 mm	 Ø3 x 10 mm
B x3	K x2



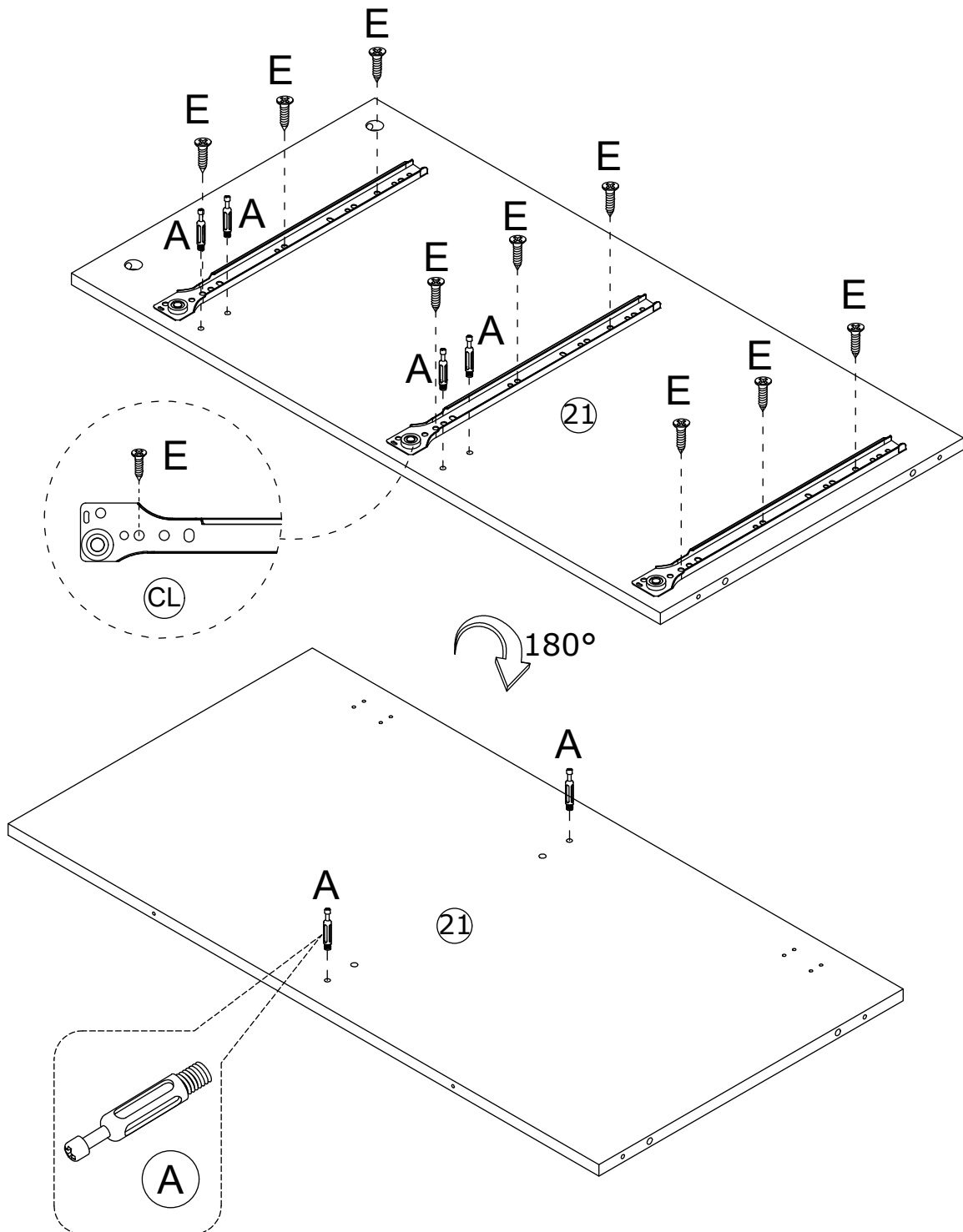

25.

 Ø6 x 35 mm	 Ø3.5x12mm	
A x6	E x9	CL x3



26.

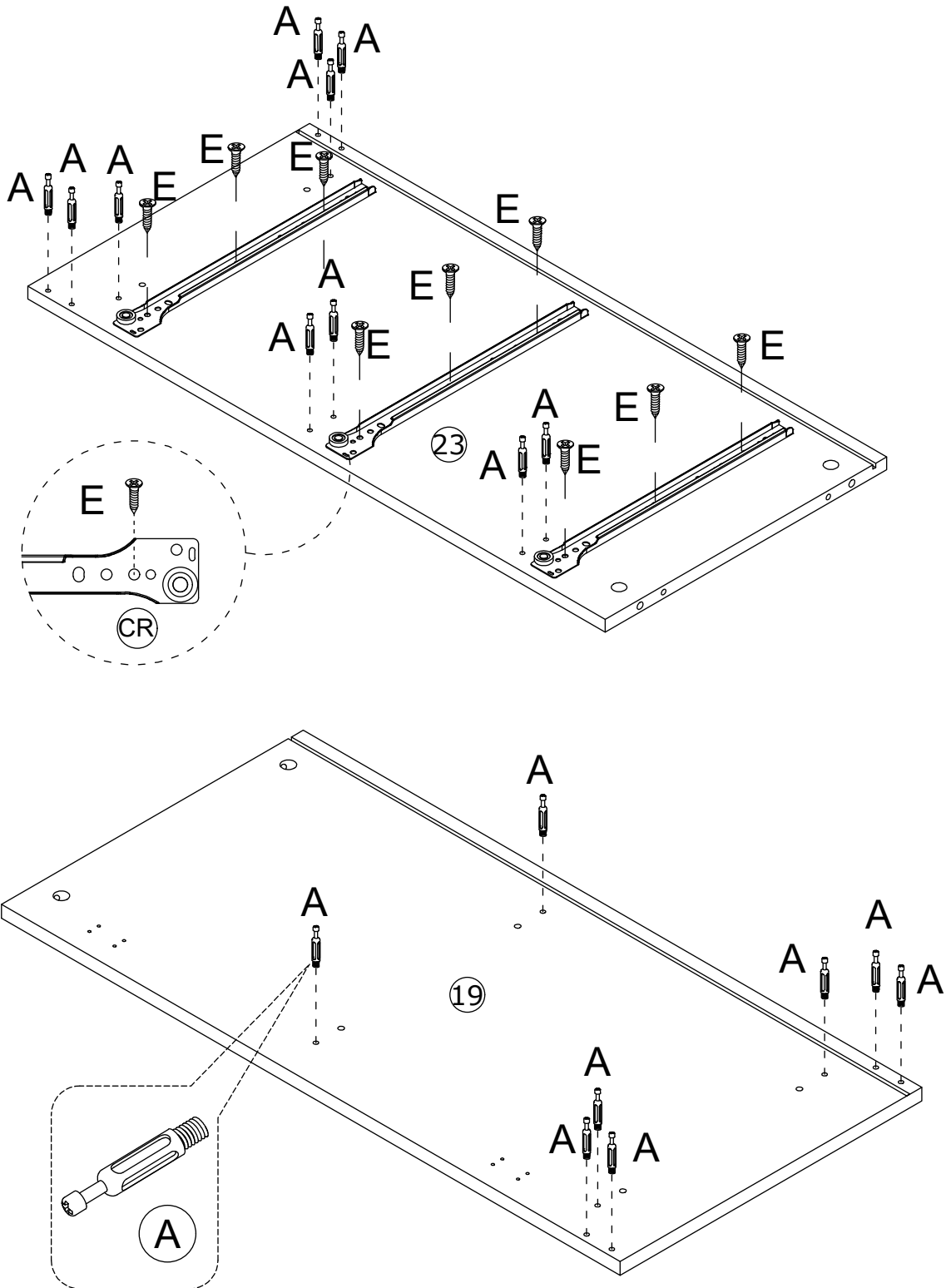

 Ø6 x 35 mm	 Ø3.5x12mm	
A x18	E x9	CR x3

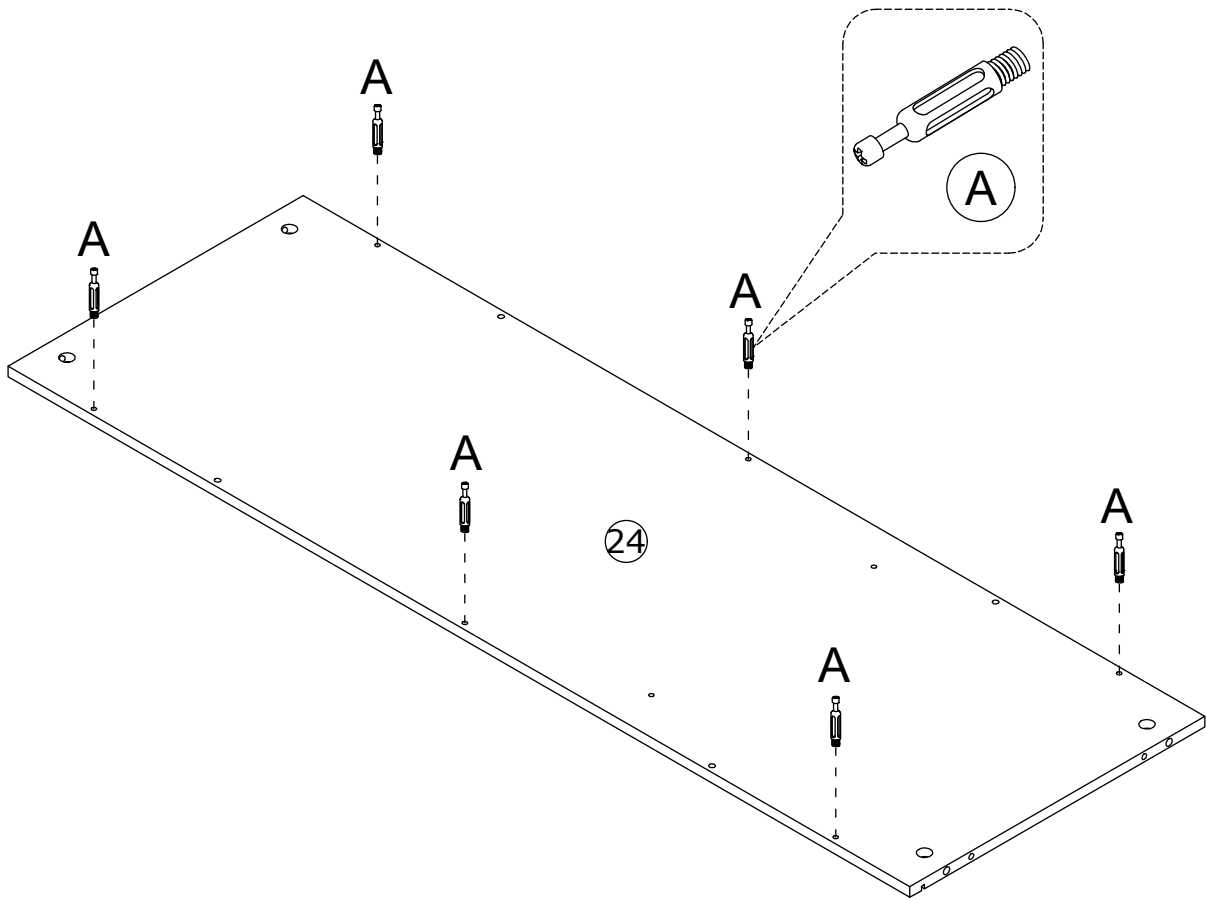
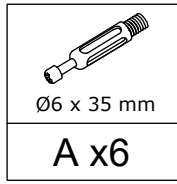

27.



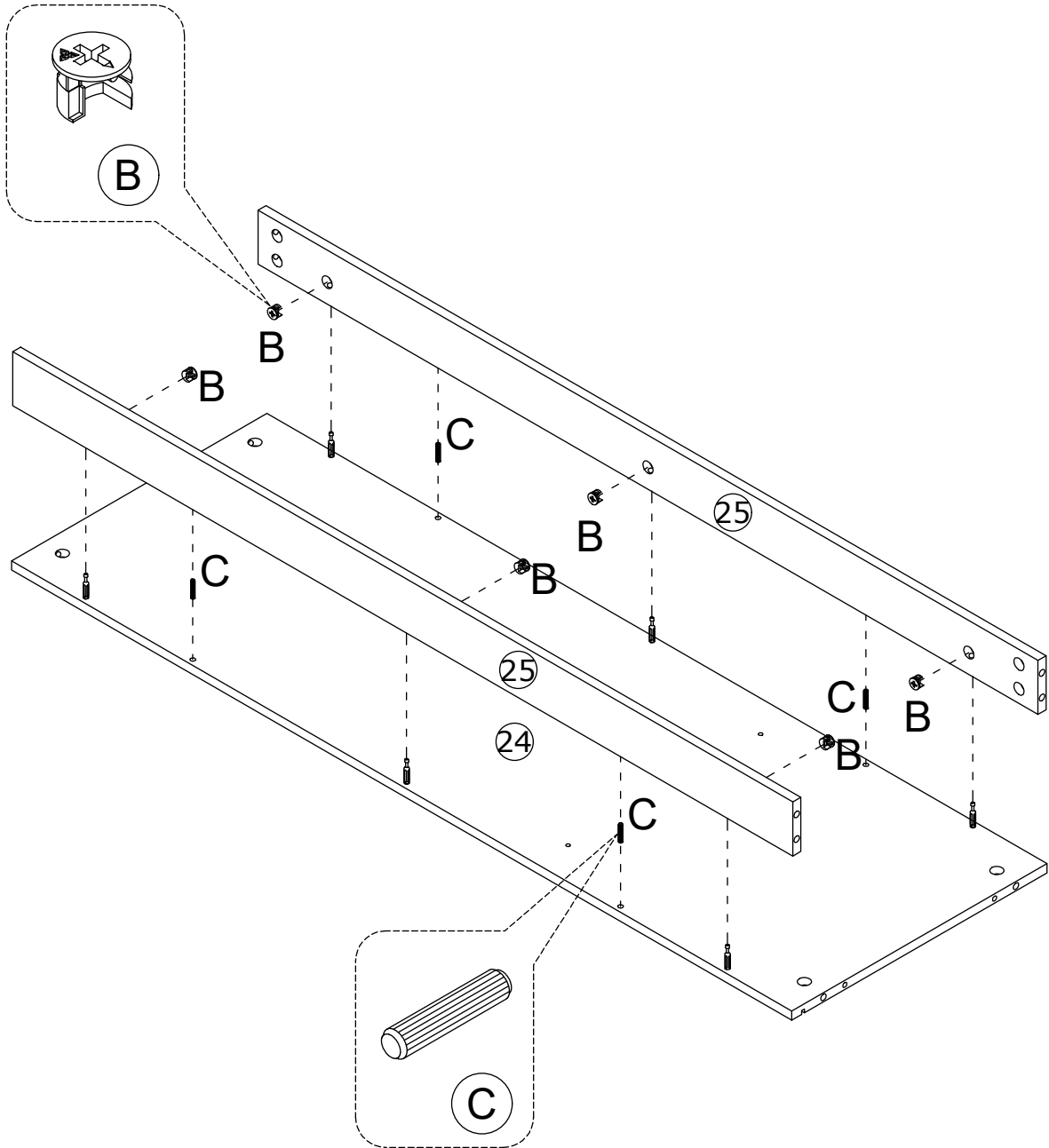

28.

 Ø15 x 9.5 mm	 Ø6 x 30 mm
B x6	C x4



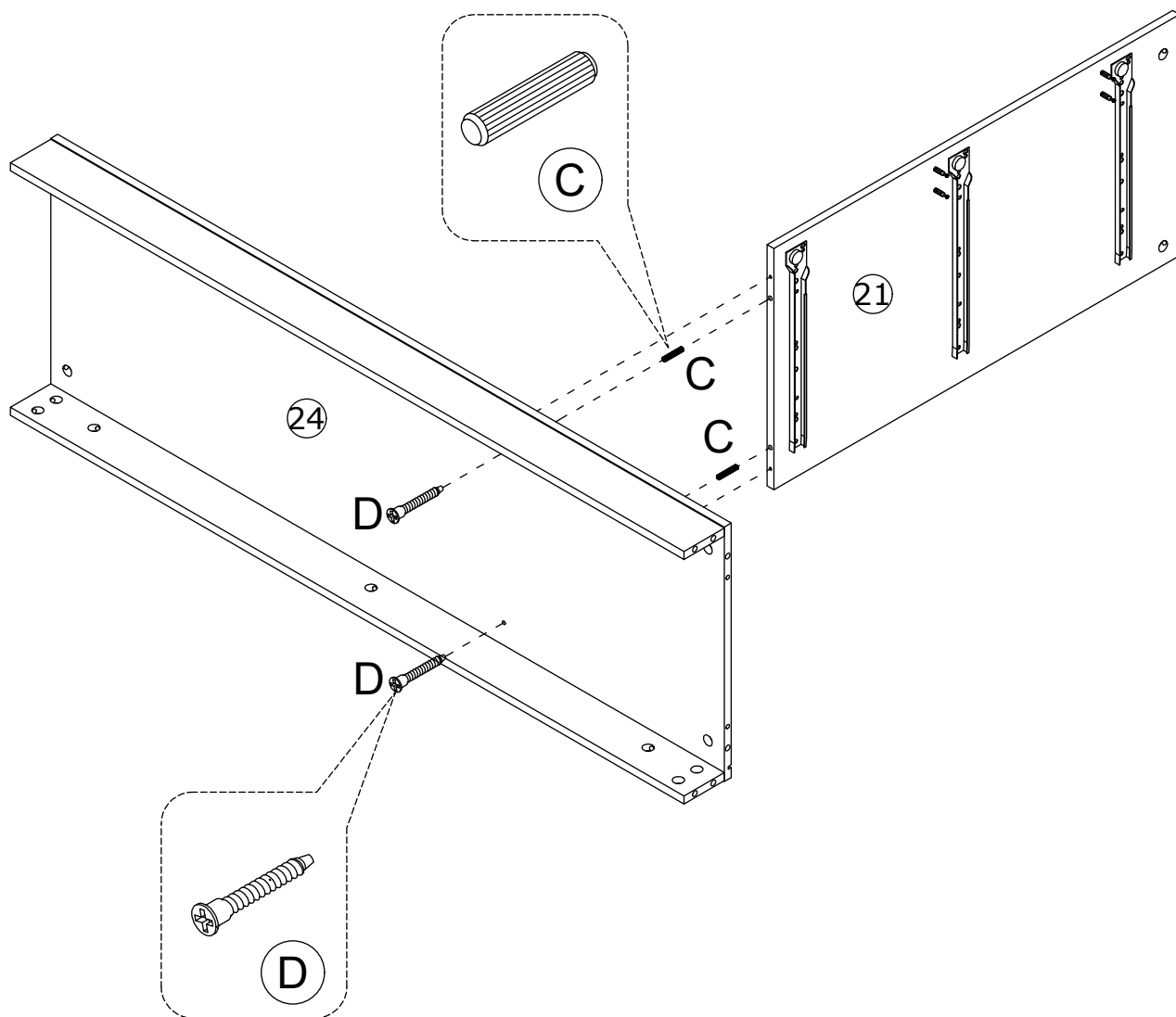

29.

 Ø6 x 30 mm	 Ø5 x 40 mm
C x2	D x2



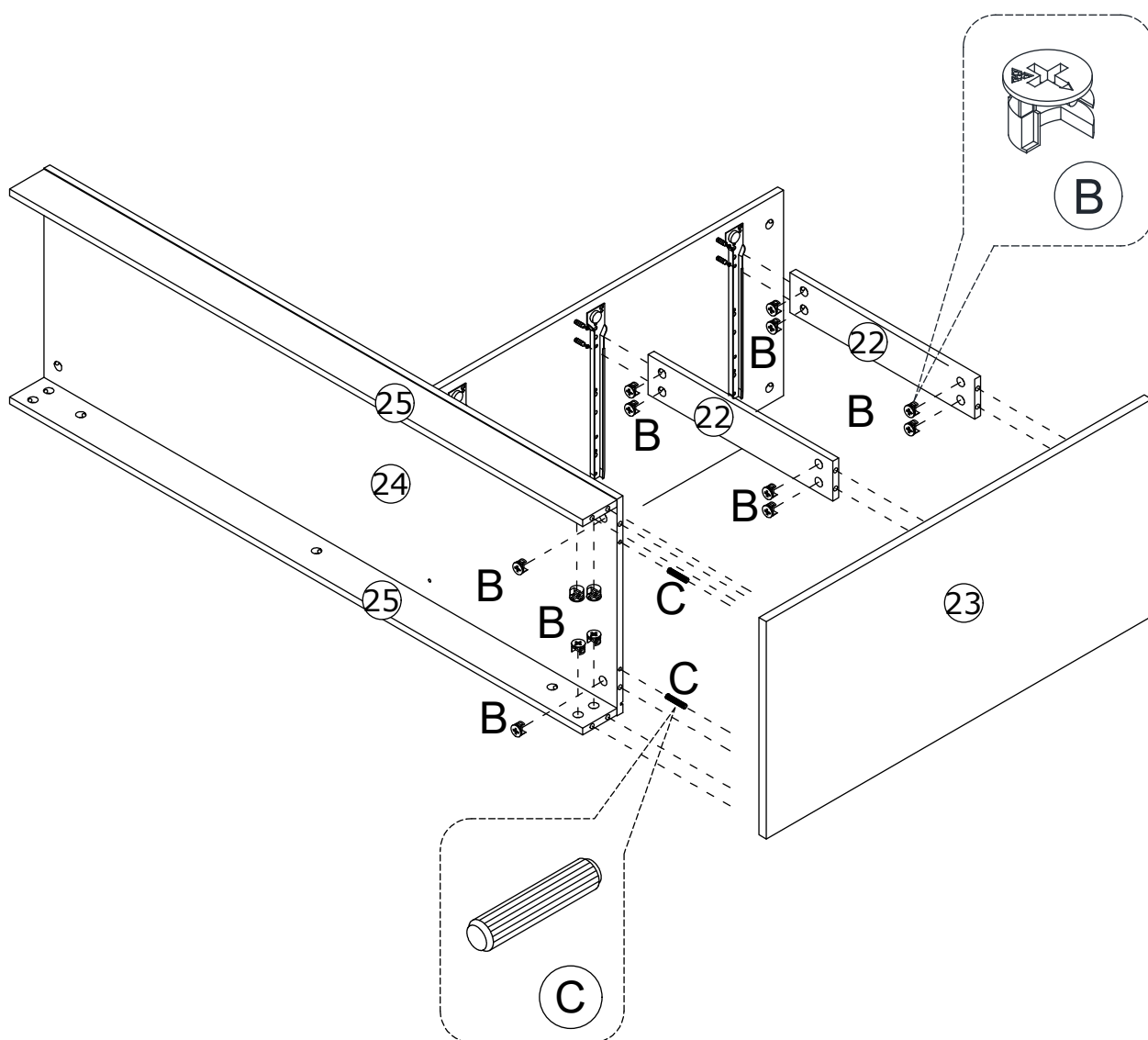

30.

	
Ø15 x 9.5 mm	Ø6 x 30 mm
B x14	C x2



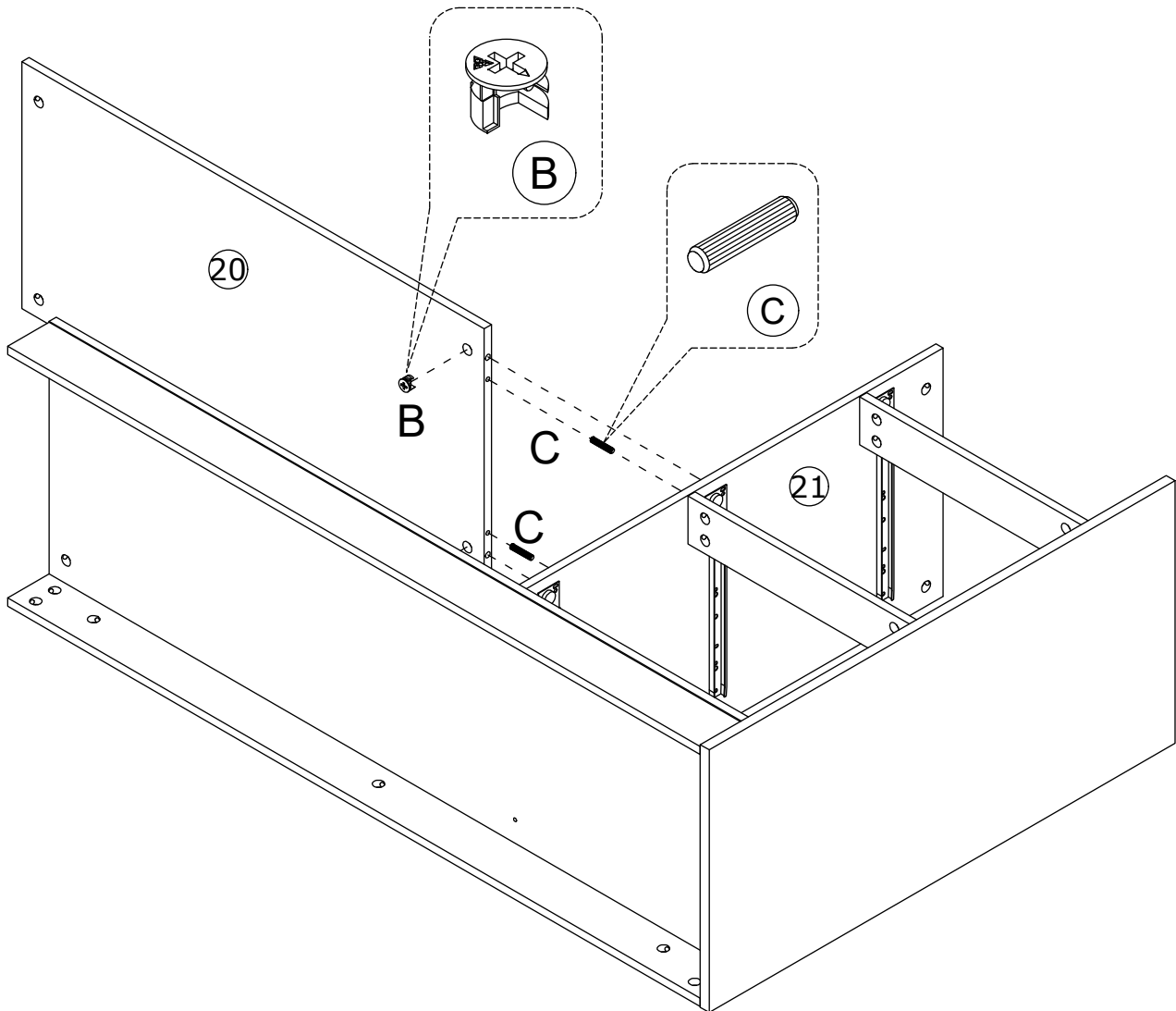

31.

 Ø15 x 9.5 mm	 Ø6 x 30 mm
B x2	C x2



32.

 Ø15 x 9.5 mm	 Ø6 x 30 mm	
B x8	C x4	S x6

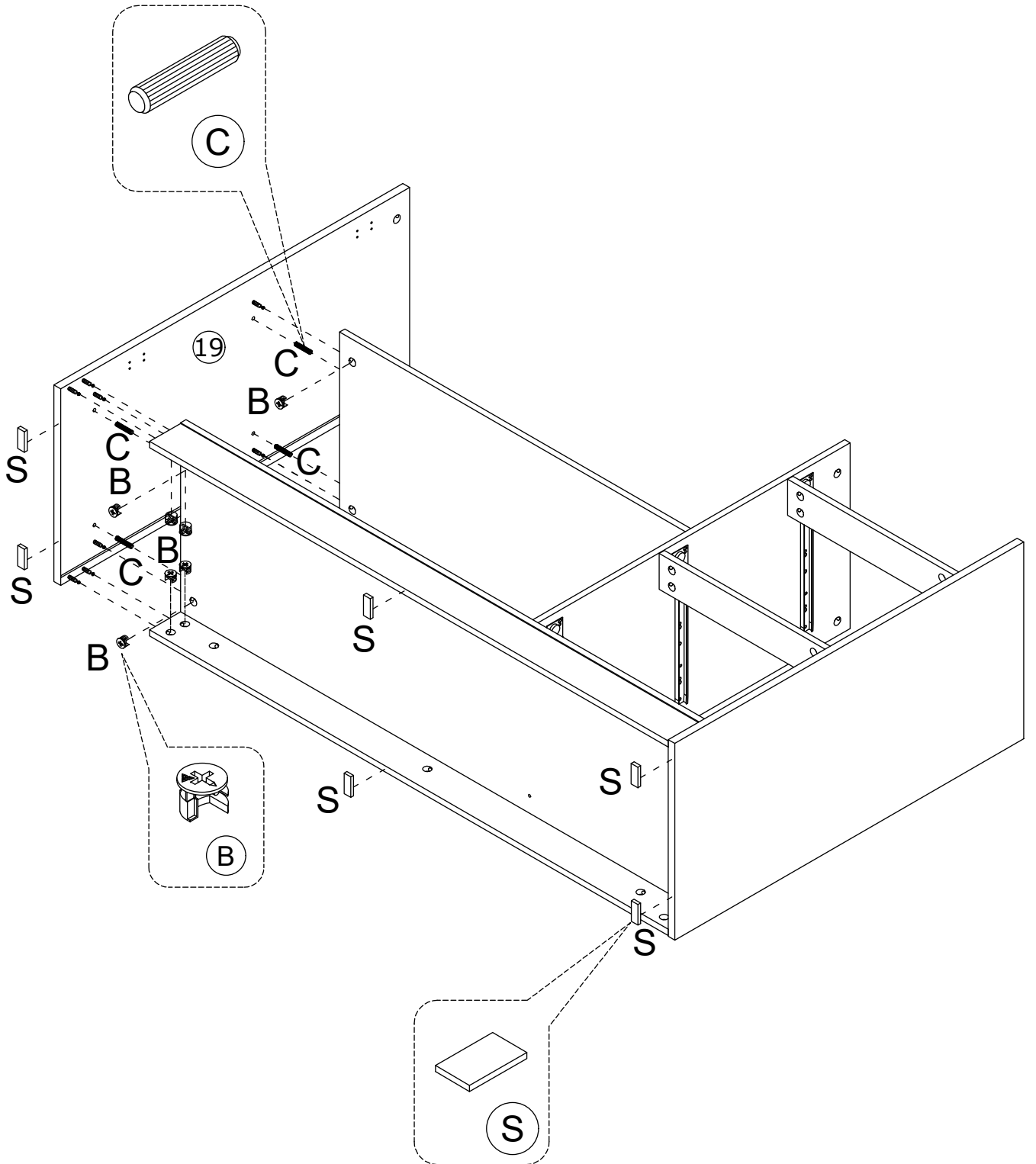

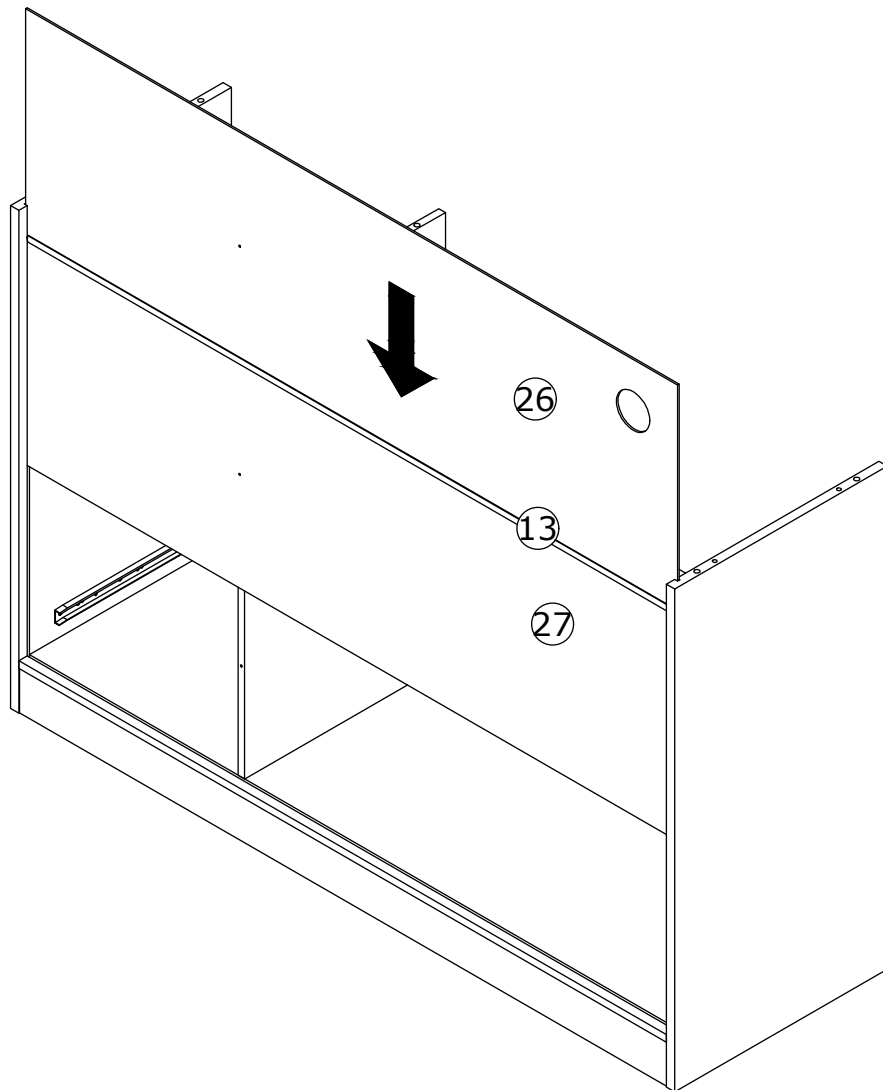

33.

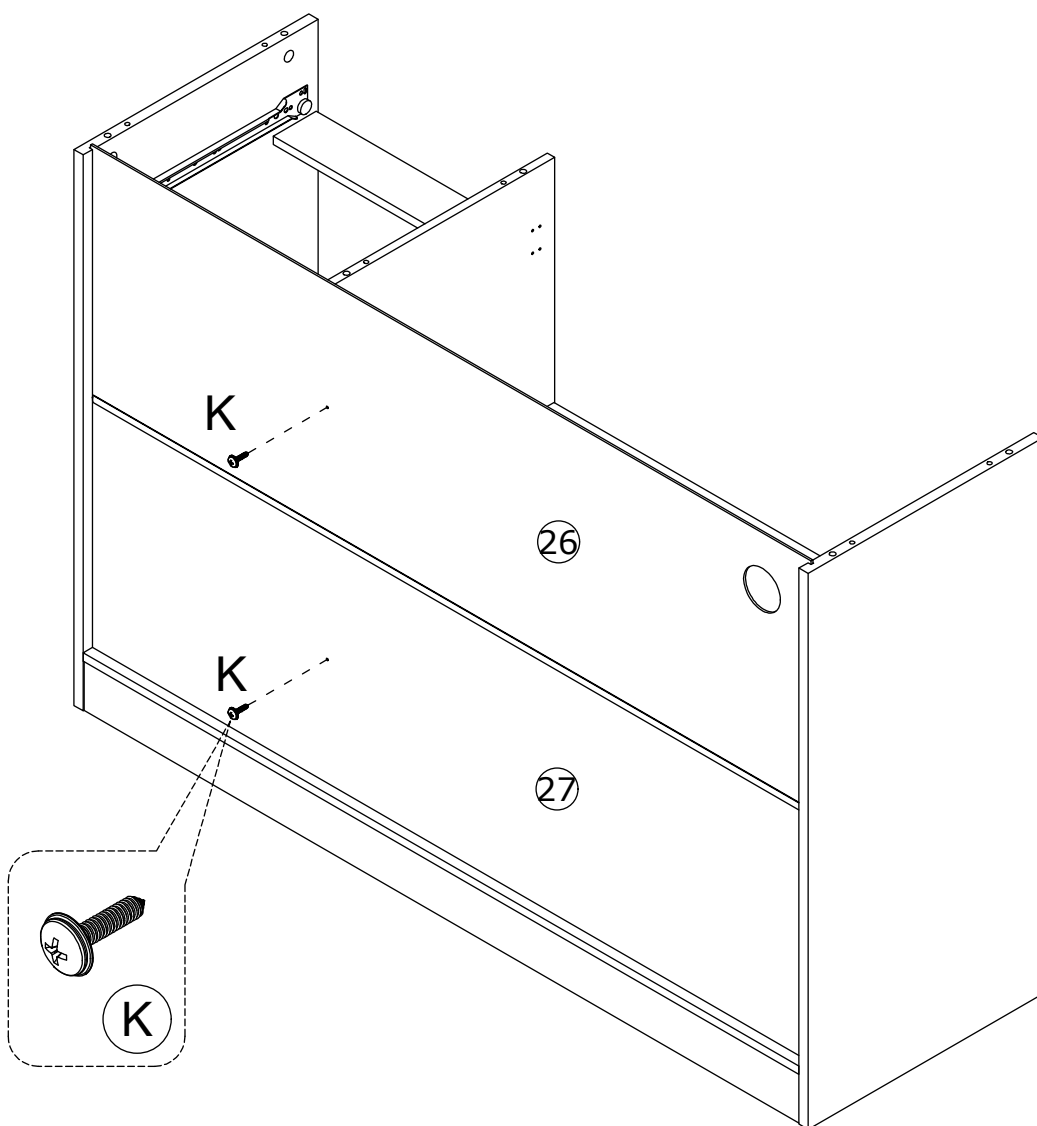
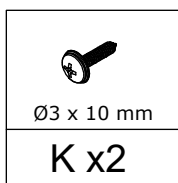

34.



35.

 Ø15 x 9.5 mm	 Ø6 x 30 mm
B x6	C x6

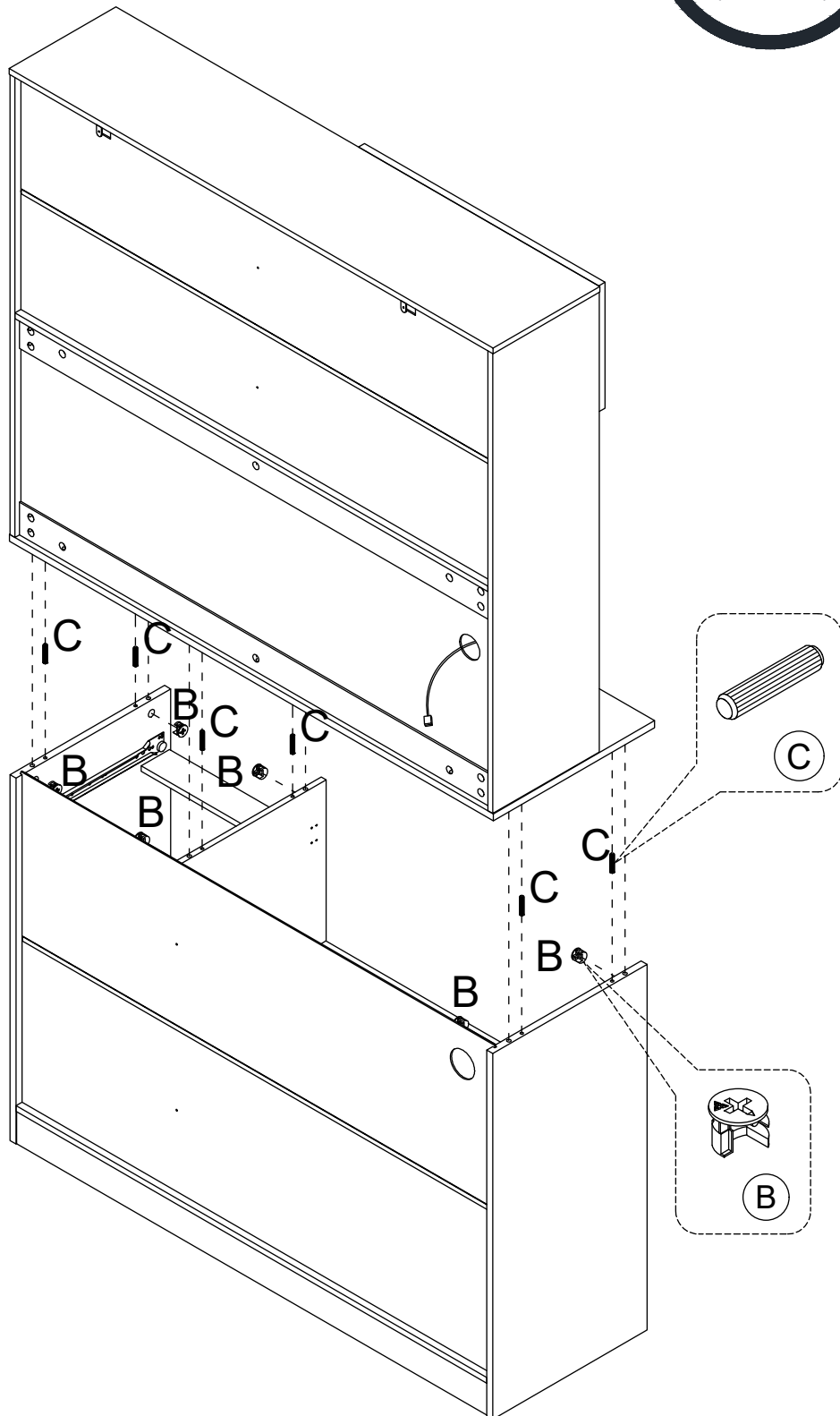

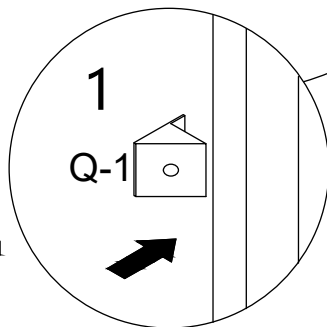
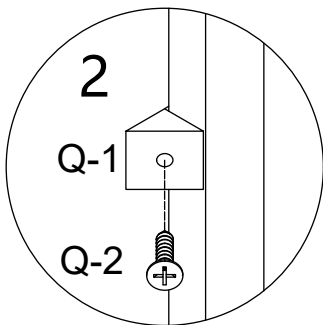
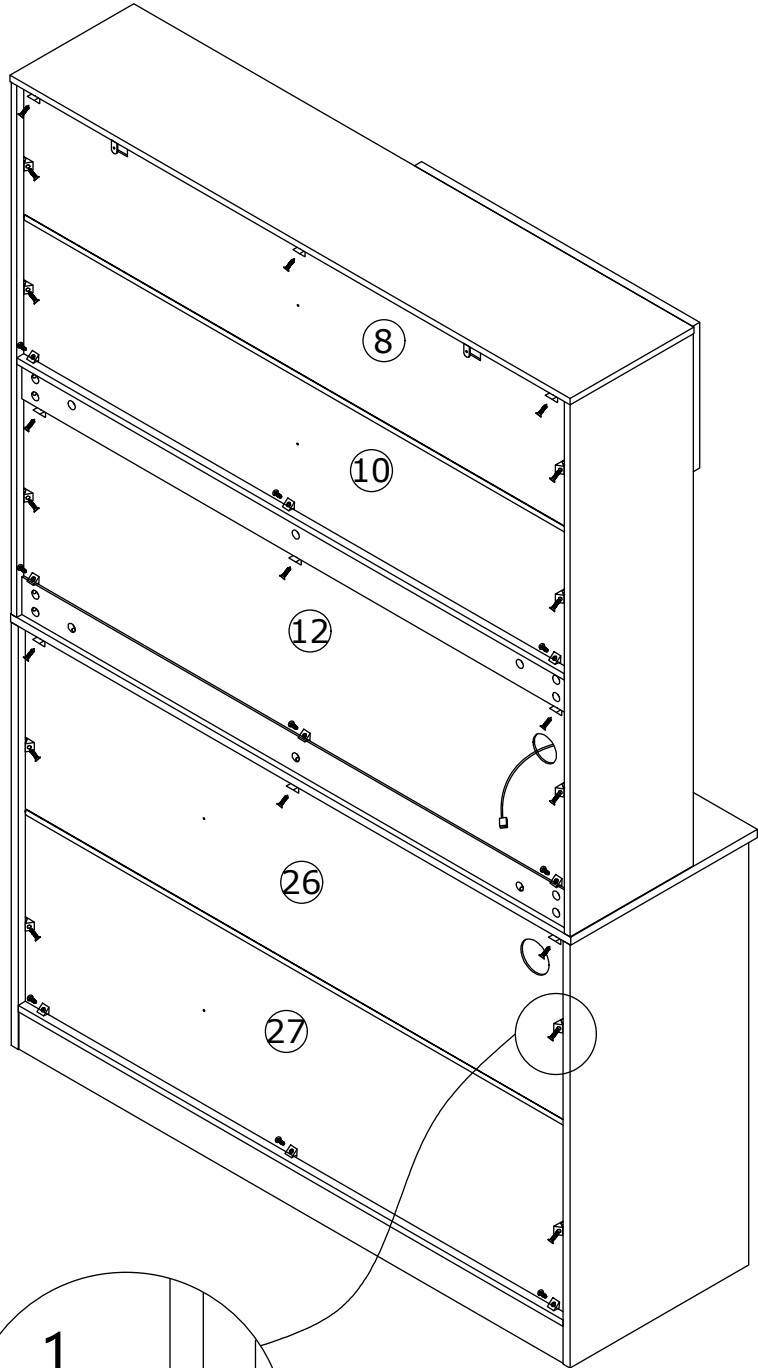
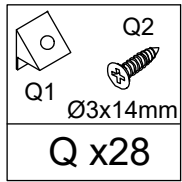

36.

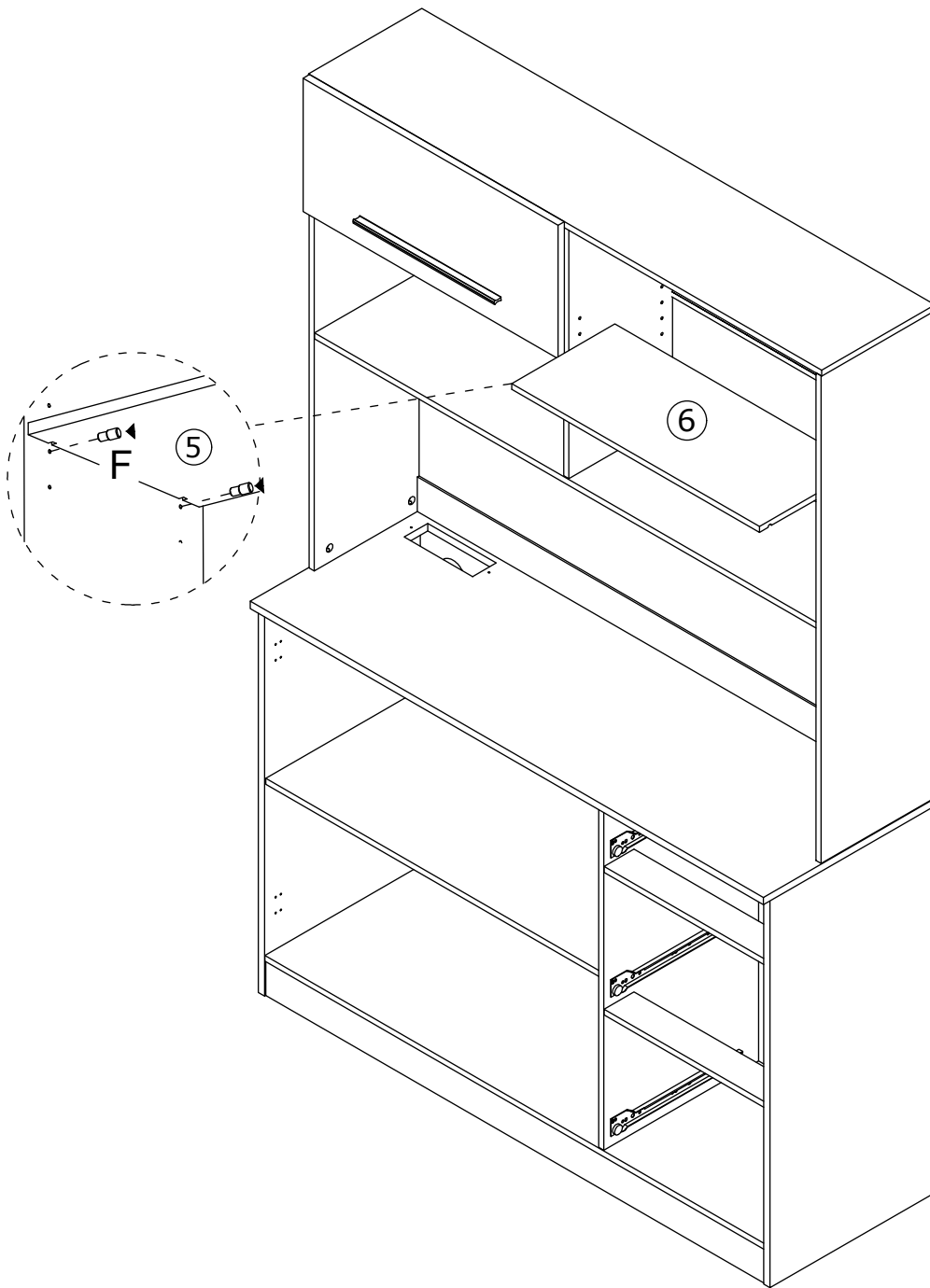
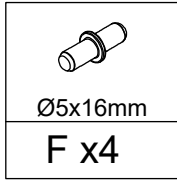

37.



38.

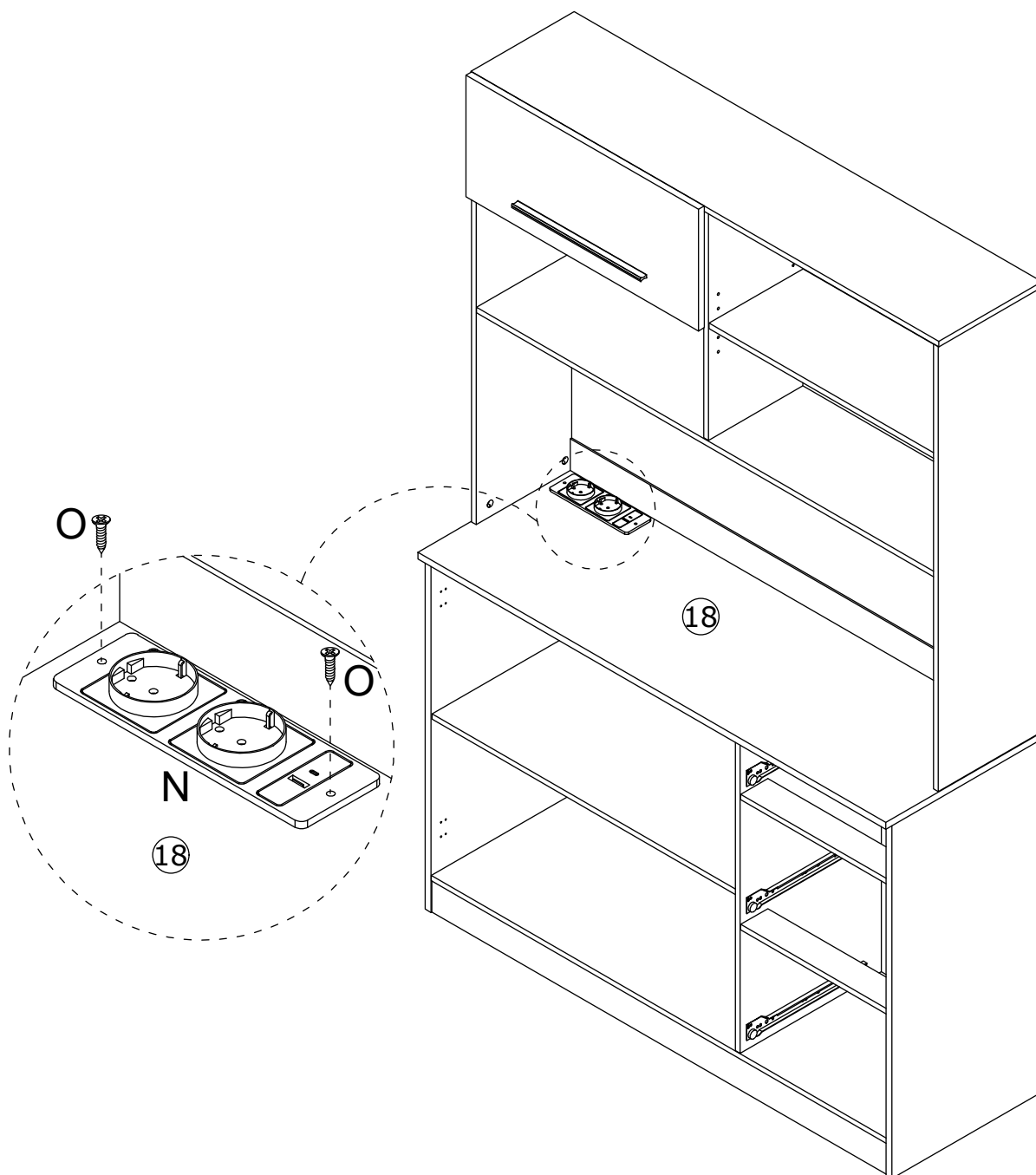

 Ø3.5x14mm	
O x2	N x1

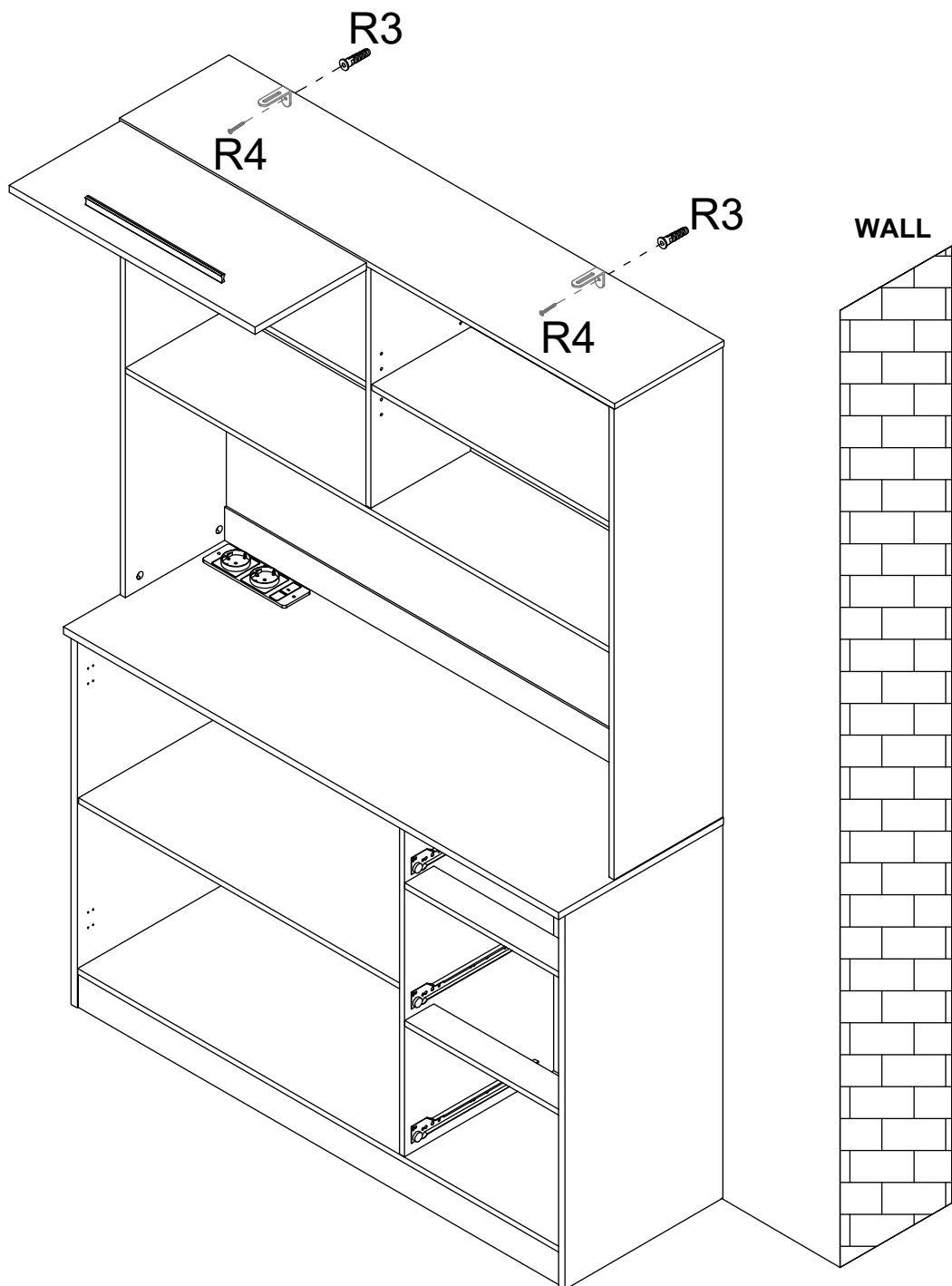
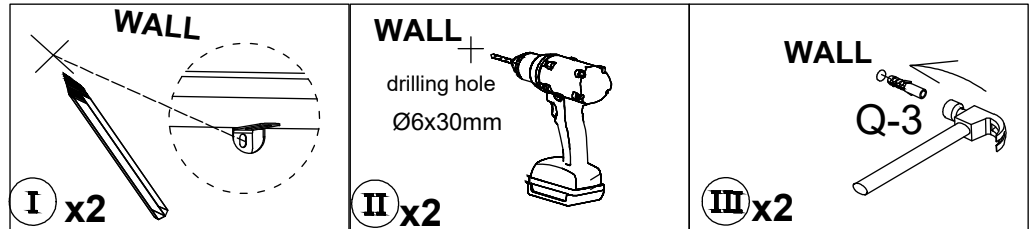
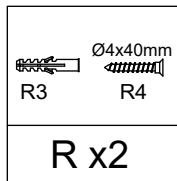

39.



40.

 Ø3.5x12mm		
E x12	I x4	J x2

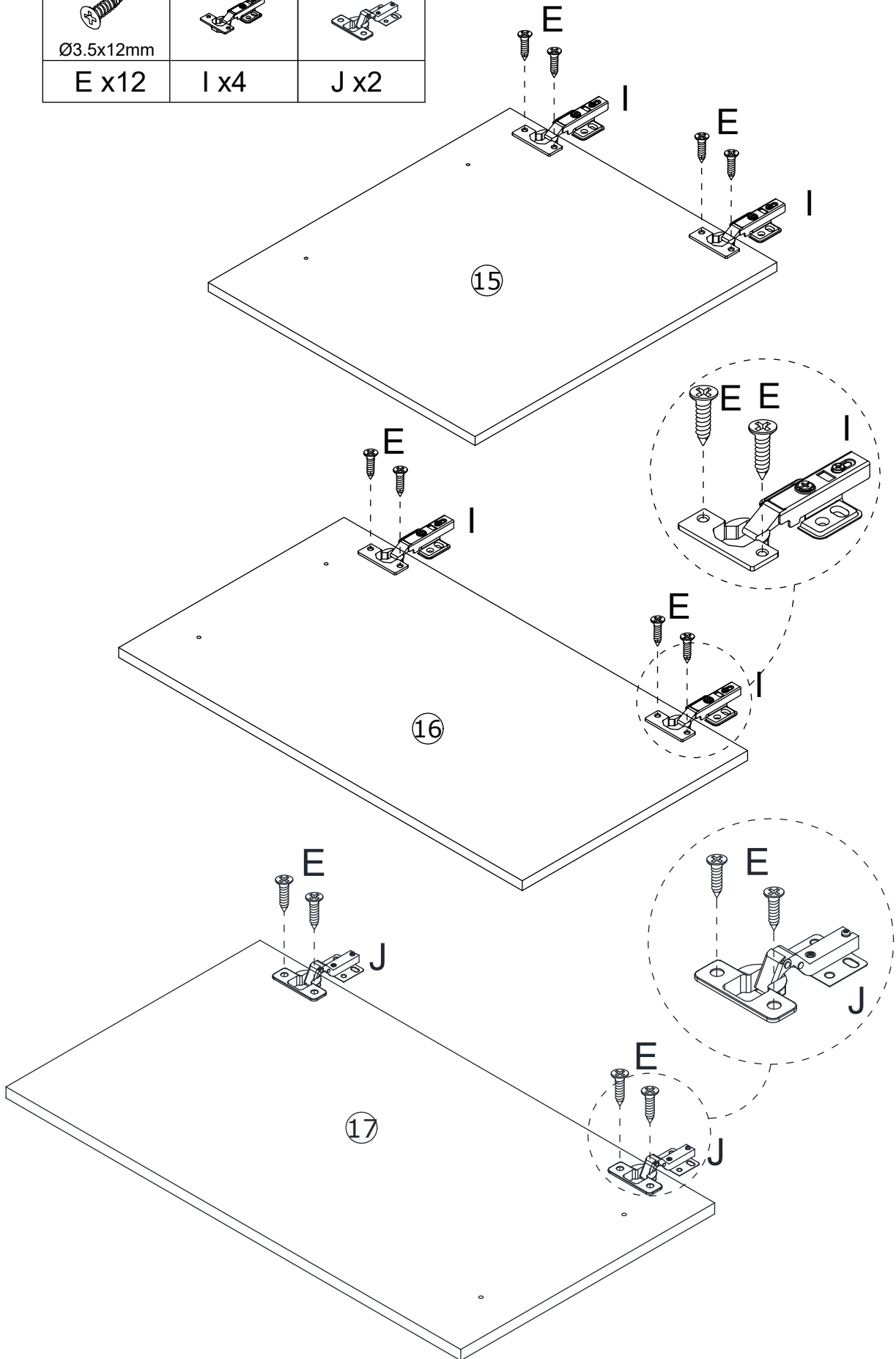

41.

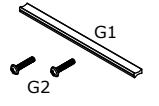
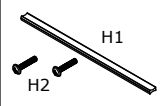
 G1 G2	 H1 H2
G x2	H x1

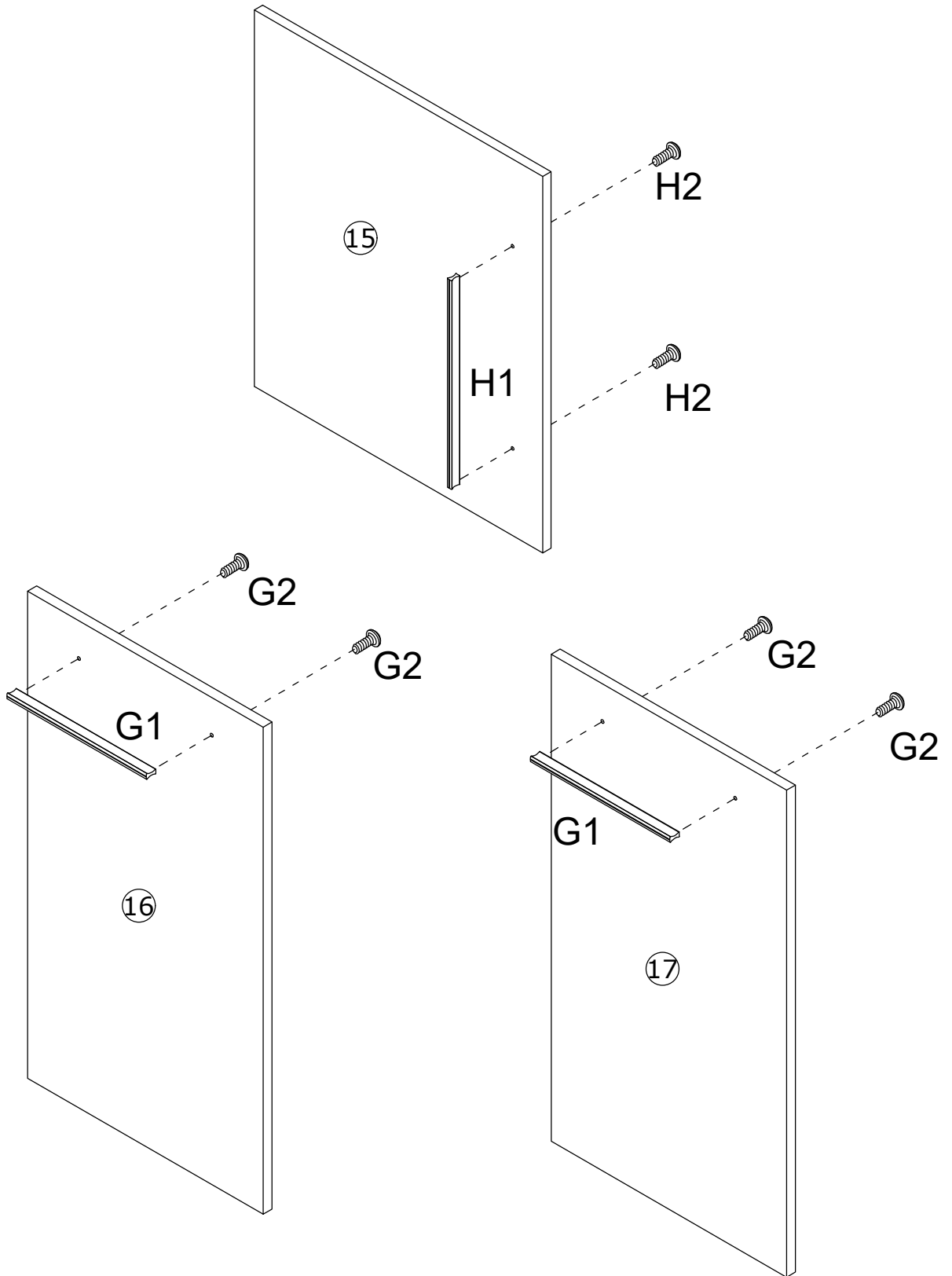

42.

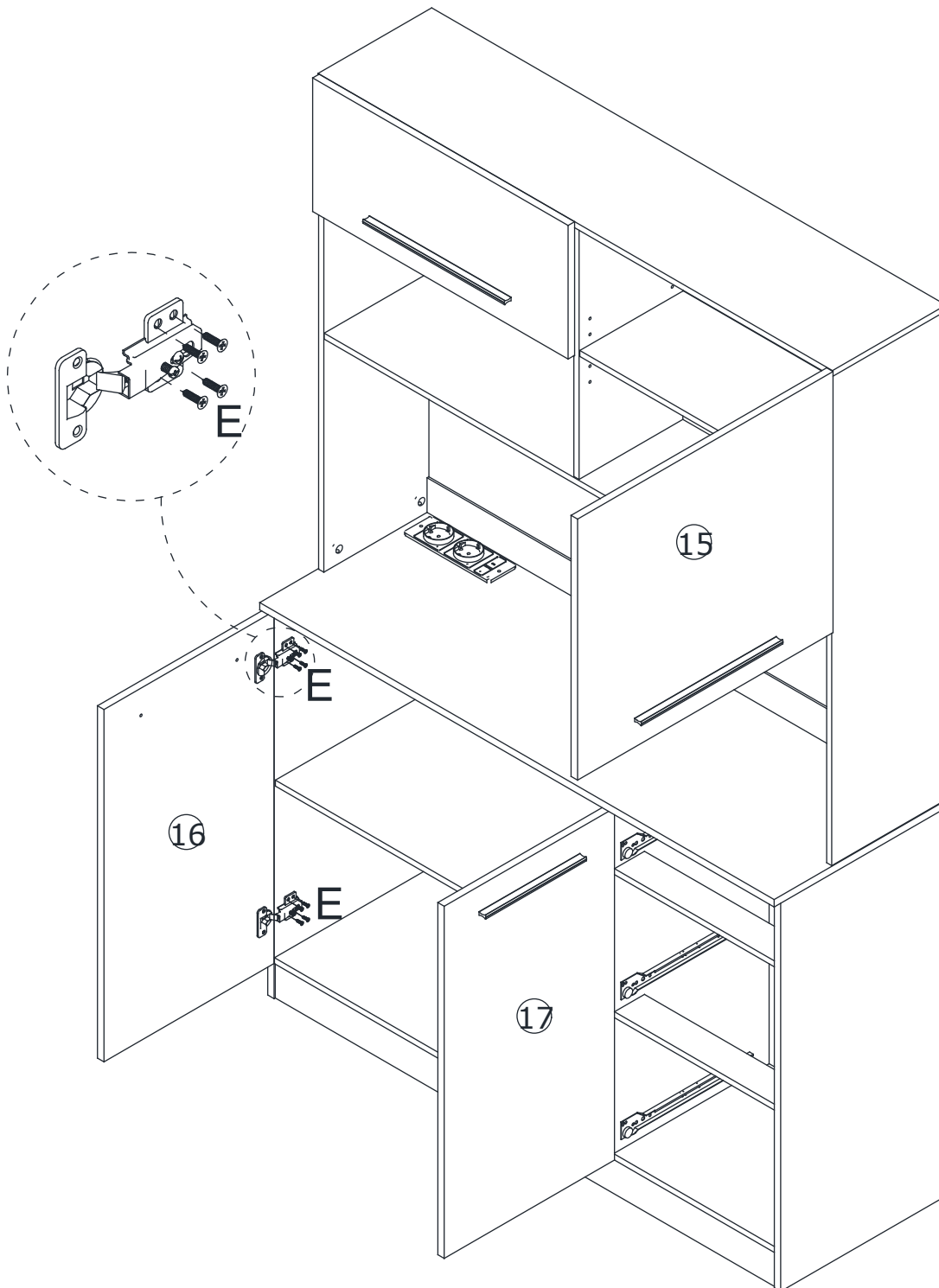
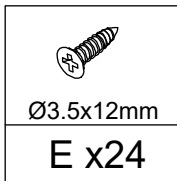

43.

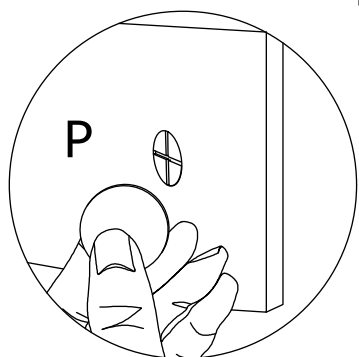
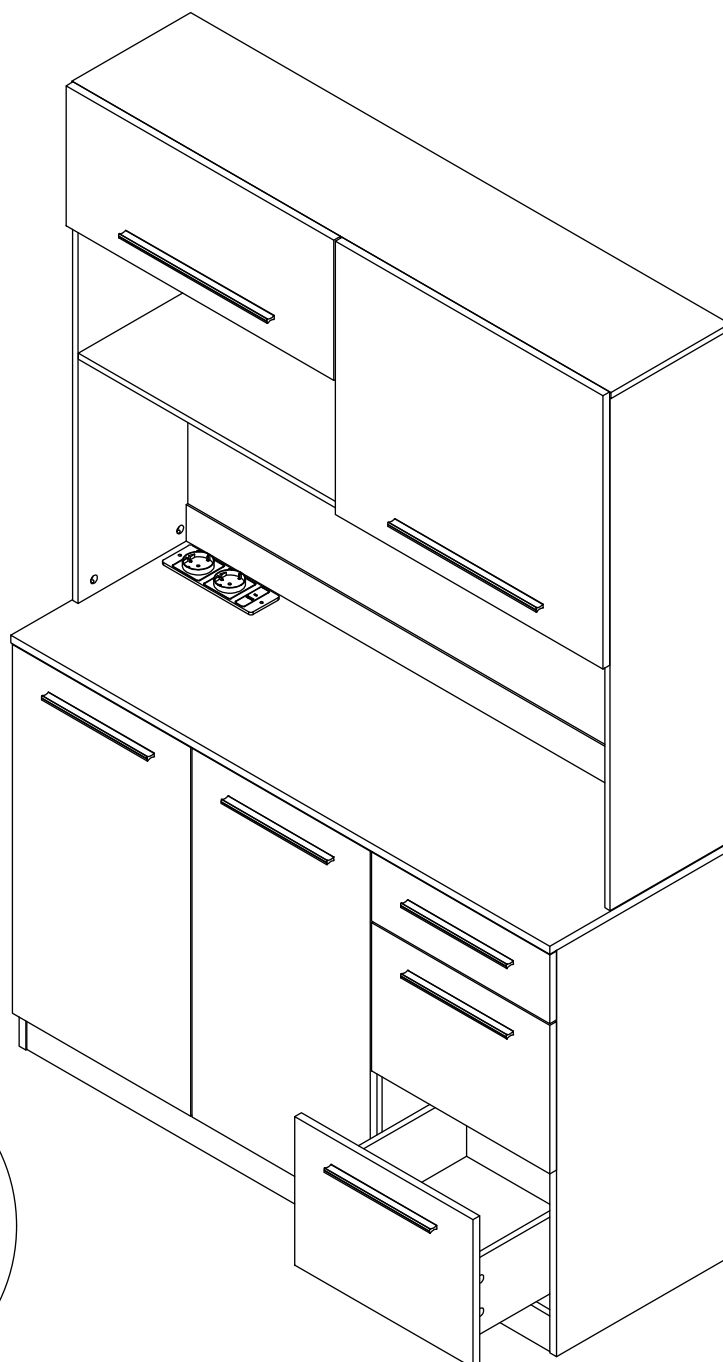
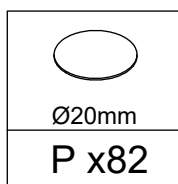

APP-PROGRAMMANWENDUNG

Klicken, um
Lampenliste
anzuzeigen
Farbrad
wechseln

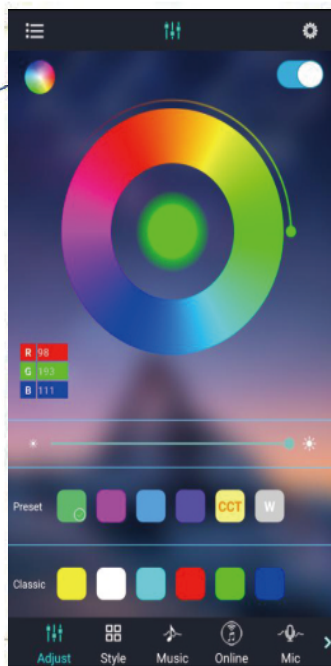

Klicken für
Einstellungsansicht

Farbe anpassen

Farbanpassung
per Quadrat-
Symbol

Schnittstelle
durch Klicken
wechseln

VERBINDUNGSSCHRITTE

- ① LED-Farbstreifen & Controller verbinden, Controller einschalten
- ② QR-Code scannen zum App-Download:



- ③ App starten, Controller suchen & verbinden
- ④ Bluetooth-Drahtlossteuerung genießen

PRODUKTMERKMALE

- Direkte Handy-Steuerung (20m Reichweite)
- Automatische Verbindung in 5 Sekunden
- Musikrhythmus-Synchronisation
- Gruppensteuerung
- Helligkeits-/Geschwindigkeitsregelung
- Unterstützt bis 10m RGB(W)-Streifen
- Automatische Sprachumschaltung (DE/EN)

ANIMATIONSEFFEKTE

- Farbverläufe
- Einfarbige/ Zweifarbige Gradienten
- Monochrome/Bunte Blinkeffekte
- Farbspringen
- Musikresponsive Effekte

HINWEIS:

Detaillierte Anleitung im
Menü "Guide"

PRODUKTPARAMETER

- Bluetooth: BLEVA 2
- Eingangsspannung: 4.5~26V
- Betriebstemperatur: -25~75 °C
- Abmessungen: 1130X22X11mm
- Gewicht: 30g
- Max. Leistung: 144W (24V)

APP PROGRAM USAGE

Click to show
the lamp list
Switch the
color wheel

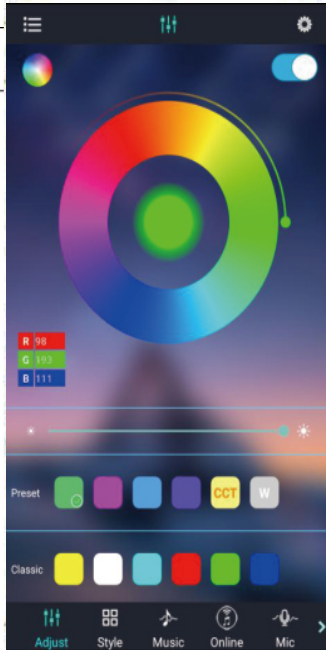

Click to display
settings view

Adjust the color

Click square icon
to adjust the color

Click to shift
the interface

Scan two-dimensional code download APP

①Connect LED color strip and controller,
power on controller

②Scan two-dimensional code download APP:



③Start APP, search and connect controller

④Enjoy the Bluetooth wireless control
experience

Notes:

detailed operating instructions,
enter the menu "Guide":

Product Parameters:

- Bluetooth: BLE V4.2
- Input Voltage: 4.5~26V
- Working Temp: -25~75°C
- Size: 1130X22X11mm
- Weight: 30g
- Max Power: 144W (24V)

LED mobile phone Bluetooth

controller Product Features

- LED Bluetooth controller is directly via
mobilephone control remote distance can reach
20m without the need to set up easy to connect
open the software within 5 seconds you can
automatically connect the controller
- Flow the rhythm of the music changes
- Group control
- Brightness, speed addition and subtraction
- Maximum can be 10 meters RGB(W) strip
- The software shows that the text is based
on the language of the mobile phone set up
automatic transformation of Chinese and English

ANIMATION EFFECTS:

- Colorful gradient
- All kinds of monochrome, double color gradient
- All kinds of monochrome, double color, colorful
flashing
- Colorful jump
- Follow the rhythm of the music changes

APP-PROGRAMMANWENDUNG

Afficher la
liste des lampes
Farbrad
Changer la
Roue chromatique

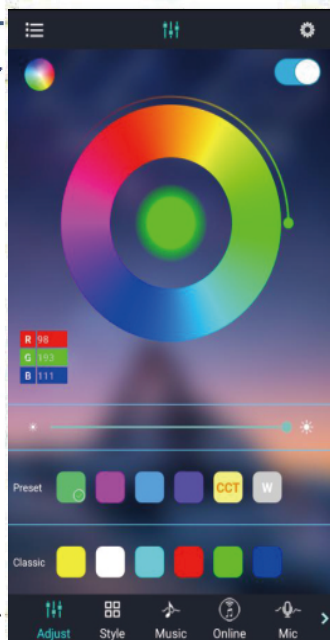

Afficher les
paramètres

ÉTAPES DE CONNEXION

- ① Connecter bande LED & contrôleur, allumer
- ② Scanner QR code pour télécharger l'app :

Ajuster la couleur



Changer d'
interface
par clic

Cliquez sur l'icône
carrée pour ajuster
la couleur.

- ③ Lancer l'app, rechercher & connecter
- ④ Profiter du contrôle Bluetooth sans fil

FONCTIONNALITÉS

- Contrôle direct par smartphone (20m)
- Connexion automatique en 5 secondes
- Synchronisation musicale
- Contrôle de groupe
- Réglage luminosité/vitesse
- Prise en charge bandes $\leq 10m$ RGB (W)
- Basculage automatique FR/EN

REMARQUE :

Guide détaillé dans le menu
"Guide"

CARACTÉRISTIQUES

- Bluetooth : BLEVA 2
- Tension d'entrée : 4.5~26V
- Température : -25~75° C
- Dimensions : 1130X22X11mm
- Poids : 30g
- Puissance max : 144W (24V)

EFFETS D'ANIMATION

- Dégradés de couleurs
- Dégradés uni/bicolores
- Clignotements mono/colorés
- Saut de couleurs
- Effets réactifs à la musique

UTILIZZO APP

Mostra lista lampade

Cambia ruota colori

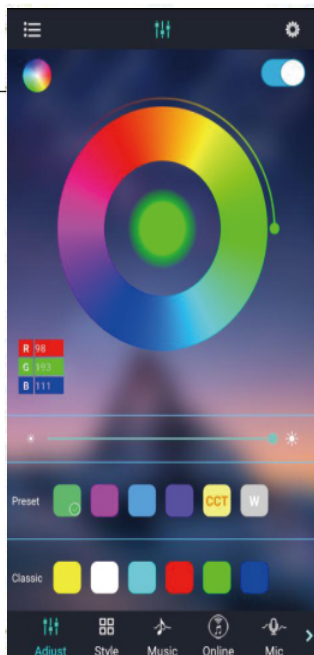

Visualizza impostazioni

Regolare il colore

Regola colore con icona quadrata

Cambia interfaccia cliccando

PASSI CONNESSIONE

- ① Collega striscia LED & controller, accendi
- ② Scansiona QR code per scaricare APP:



- ③ Avvia APP, cerca & connetti controller
- ④ Goditi controllo wireless Bluetooth

CARATTERISTICHE

- Controllo diretto smartphone (20m)
- Connessione automatica in 5 secondi
- Sincronizzazione ritmo musicale
- Controllo di gruppo
- Regolazione luminosità/velocità
- Supporto strisce $\leq 10m$ RGB(W)
- Auto switch IT/EN

EFFETTI ANIMAZIONE:

- Sfumature colore
- Gradienti mono/bicolori
- Luci lampeggianti mono/colorate
- Salto colori
- Effetti reattivi alla musica

NOTA:

Guida completa nel menu "Guide"

SPECIFICHE:

- Bluetooth: BLEVA 2
- Tensione ingresso: 4.5~26V
- Temperatura: -25~75° C
- Dimensioni: 1130X22X11mm
- Peso: 30g
- Potenza max: 144W (24V)

USO DE LA APLICACIÓN

Mostrar lista de
Lámparas
Cambiar rueda de color

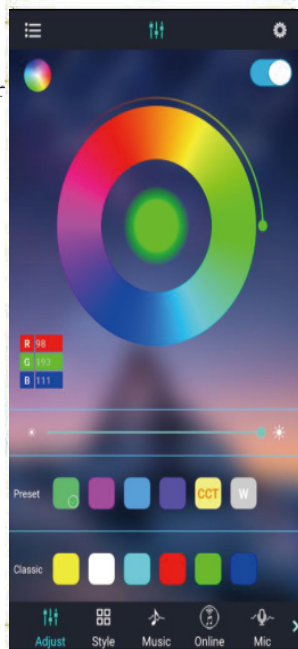

Ver ajustes

Ajustar el color

Clic
Ajustar color
con icono cuadrado

Cambiar interfaz
haciendo clic

PASOS DE CONEXIÓN

- ① Conectar tira LED y controlador, encender
- ② Escanear QR para descargar APP:



- ③ Iniciar APP, buscar y conectar
- ④ Disfrutar control inalámbrico Bluetooth

NOTA:

Guía completa en menú "Guide"

ESPECIFICACIONES:

- Bluetooth: BLEVA 2
- Voltaje entrada: 4.5~26V
- Temperatura: -25~75° C
- Tamaño: 1130X22X11mm
- Peso: 30g
- Potencia máx: 144W (24V)

CARACTERÍSTICAS

- Control directo móvil (20m alcance)
 - Conexión automática en 5 segundos
 - Sincronización ritmo musical
 - Control grupal
 - Ajuste brillo/velocidad
 - Soporte tiras ≤10m RGB(W)
 - Auto cambio ES/EN
- ### EFFECTOS DE ANIMACIÓN:
- Degradados de color
 - Transiciones mono/bicolores
 - Destellos monocromáticos/color
 - Salto de colores
 - Efectos reactivos a música



CERTIFICATE OF CONFORMITY (COC)

NO.: S250221068001-1

The following products have been tested by us and found compliance with the RoHS Directive 2011/65/EU Annex II amending Annex (EU) 2015/863 of CE Directive.

Customer : Shenzhen Huaxinwang Lighting Industry Co., Ltd
Address : Room 702, No. 108 Xingang Road, Chang'an Town, Dongguan City, Guangdong Province
Manufacturer : Shenzhen Huaxinwang Lighting Industry Co., Ltd
Address : Room 702, No. 108 Xingang Road, Chang'an Town, Dongguan City, Guangdong Province
Sample Name : LED light strip
Tested Model : 5050Fantasy
Additional Model : 2835, 3528, 5050RGB, 3535RGB, 0807Fantas, 3332Fantasy, 5730, 3014
Report No: : S250221068001-1
Test method : EN 62321-3-1:2014& EN 62321-5:2014& EN 62321-4:2014+A1:2017& EN 62321-7-1:2015& EN 62321-7-2:2017& EN 62321-6:2015 & EN 62321-8:2017



Signature: 
Technical director
Signed for and on behalf of
Soar Testing Certification (GuangDong) Co., Ltd.
Mar 03, 2025

Note: This certification is part of the full test report(s) and should be read in conjunction with it. The certificate is based on a single evaluation of one sample of above-mentioned products. It does not imply an assessment of the whole production and does not permit the use of the test lab logo.

Lab name: Soar Testing Certification (GuangDong) Co., Ltd.
Post Code: 523945

Tel: (86-769) 38937518

Address: Room 1093, No.12, East of Houjie Avenue, Houjie, Dongguan, Guangdong, China
E-mail: service@soar-cert.com Website: <http://www.soartestlab.com>

CERTIFICATE OF CONFORMITY

Certificate No. FCS202502225CA01

Product LED light strip

Brand Name N/A

Model(s) No. 2835

Series Model 3528,5050RGB,3535RGB,0807Fantas,5050Fantasy,3332Fantasy,5730,3014

Holder Shenzhen Huaxinwang Lighting Industry Co., Ltd

Address Room 702, No. 108 Xingang Road, Chang'an Town, Dongguan City, Guangdong Province

Manufacturer Shenzhen Huaxinwang Lighting Industry Co., Ltd

Address Room 702, No. 108 Xingang Road, Chang'an Town, Dongguan City, Guangdong Province

Report No. FCS202502225E01



TEST STANDARDS:

EN 55015:2019+A11:2020,
EN IEC 61547-2023
EN IEC 61000-3-2:2019/A1:2021
EN 61000-3-3:2013/A2:2021/AC:2022-01

The applicant of the certificate is authorized to use this certificate in connection with EC declaration of conformity to the Directive. The certificate is only applicable to the equipments described above.

The submitted sample of the above equipment has been tested and found to comply with the following European Directive:

EMC Directive - 2014/30/EU



Approved by:

Jack Wang
A circular blue stamp is placed over the signature. The stamp contains the text 'FUNAS CERTIFICATION SYSTEM' around the perimeter and 'FCS' in the center. The signature 'Jack Wang' is written in black ink over the stamp.

Feb. 27, 2025

Jack Wang/Managerial

The statement is based on a single evaluation of the sample of above mentioned product(s). It does not imply an assessment of the whole production.

Dongguan Funas Testing Technology Co.,Ltd.

Add: Room 105, 1/F., Baohao Technology Building 1, No.15, Gongye West Road,
Songshan Lake Hi-Tech Industrial Area, Dongguan, Guangdong, China
Tel: 0769-27280901, Web: <http://www.fcs-lab.com>, E-mail: andy.yue@fcs-lab.com

Shenzhen ZKT Technology Co., Ltd.
 1/F, No. 101, Building B, No. 6, Tangwei Community Industrial Avenue,
 Fuhai Street, Bao'an District, Shenzhen, China



Certificate of Compliance

Certificate Number: ZKT-25070215182C

Certificate's Holder : Dongguan Yihong Hardware Electronics Co., Ltd
 Room 1106, No.2, Shangheng Road, Chang' an Town,
 Dongguan

Manufacturer : Dongguan Yihong Hardware Electronics Co., Ltd
 Room 1106, No.2, Shangheng Road, Chang' an Town,
 Dongguan

Trade Mark : N/A

Product : LED controller

Model(s) : YH-6183
 YH-252, YH-284, YH-290, YH-287, YH-358, YH-360, YH-6180,
 YH-6184

Requirement	Standard	Report No.
Art.3.1(a) Safety	EN IEC 62368-1:2024+A11:2024	ZKT-25070215183S
Art.3.1(a) Health	EN IEC 62311:2020 EN 50665:2017	ZKT-25070215182E-1
Art.3.1(b) EMC	ETSI EN 301 489-1 V2.2.3 (2019-11) ETSI EN 301 489-17 V3.3.0 (2024-07)	ZKT-25070215182E-2
Art.3.2 Radio	ETSI EN 300 328 V2.2.2 (2019-07)	ZKT-25070215182E-3

This Attestation of Compliance is issued on a voluntary basis for electrical equipment below the voltage limits of Radio Equipment Directive (RED) 2014/53/EU. The essential requirements are fulfilled accordingly based on the technical specifications applicable at the time of issuance.



This Certificate of Conformity is based on single evaluation of the submitted sample(s) of the above mentioned product. It does not imply an assessment of the whole product and relevant Directives to be observed.

CERTIFICATE OF CONFORMITY

No.: PTC25102309601C-EN01

Applicant : Dongguan Yihong Hardware electronics Co., LTD
Address : Room 901, No. 2, Shangheng Road, Chang'an Town,
Dongguan City, Guangdong Province, 523880 China
Manufacturer : Dongguan Yihong Hardware electronics Co., LTD
Address : Room 901, No. 2, Shangheng Road, Chang'an Town,
Dongguan City, Guangdong Province, 523880 China
Product Name : Remote control
Test Sample Model : YH-448G
Other Sample Model : YH-6181, YH-6183, YH-629, YH-RF10, YH-RF11, YH-RF17,
YH-RF14, YH-RF24, YH-RF16, YH-252, YH-248R, YH-248G,
YH-899, YH-689

The submitted sample of the above equipment has been tested and found to comply with the following European Directive:

RoHS Directive 2011/65/EU & EU No.2015/863

The standard(s) used for showing compliance with the essential requirements:

Applicable Standard(s)	Test Report(s) Number
IEC 62321-1:2013, IEC 62321-2:2021 IEC 62321-3-1:2013, IEC 62321-3-2:2020 IEC62321-4: 2013+AMD1:2017 IEC 62321-5:2013 IEC 62321-6:2015, IEC 62321-7-1: 2015 IEC 62321-7-2: 2017, IEC 62321-8:2017	PTC25102309601C-EN01

This certificate is part of the full test report(s) and should be read in conjunction with it. This certificate is based on an evaluation of one sample of above mentioned product. It does not imply assessment of the production of the product. Without the written approval of Precise Testing & Certification (Guangdong) Co., Ltd., this certificate is not permitted to be reproduced, except in full. It is not permitted to use the test lab's logo.

RoHS



Jacky Ou
Jacky Ou
Manager

Date: Dec. 04, 2025



Certificate of Compliance

RoHS Directive 2011/65/EU appendix II Revised instructions (EU) 2015/863 of the European parliament and of the council on the restriction of the use of certain hazardous substances in electrical and electronic equipment

Issue Date: Nov.27, 2025

Company Name	: GUANG TAI ENTERPRISE CO.,LTD
Address	: Rm402,Bldg 4,No.2 Dapianmei Rd.Dapianmei Village,Dalingshang DONGGUAN GUANGDONG
Manufacturer	: GUANG TAI ENTERPRISE CO.,LTD
Address	: Rm402,Bldg 4,No.2 Dapianmei Rd.Dapianmei Village,Dalingshang DONGGUAN GUANGDONG
Sample Name	: Furniture Power Distribution Unit
Sample Model	: JN02-00-21;JN02-00-111;JN02-00-112;JN02-00-212; JN02-00-22;JN00-00-02K;JN02-00-113K;JN02-00-113; JN02-00-213;JN02-00-23;JN00-00-03K;JN00-00-03; JN00-00-04K;JN00-00-04; JN02-00-23K

This certificate of compliance is based on a test procedure or an evaluation of the above-mentioned product. This is to certify that the above-mentioned product is in compliance with the According to IEC 63000:2018+AMD1:2017 and RoHS Directive 2011/65/EU Revised instructions (EU) 2015/863 of the European parliament.

It is only valid in connection with the test report (Report No.: COBO25110736-R1)

RoHS

Signed for and on Behalf of COBO



Sam Xie / Technical Manager

GUANGDONG TI COBO TESTING CO.,LTD.

EA601,Yishili Building No.9,Zongbu 2nd Road,Songshan Lake Sci.&Tech. Park,Dongguan,Guangdong,China

Tel:86-769-26622263

Fax:86-769-26622012





CERTIFICATE OF CONFORMITY

No.: LCT-250803286238

Applicant.....: GUANG TAI ENTERPRISE CO.,LTD.
Address.....: No. 2, Dapianmei District, Dalingshan Town, Dongguan City, Guangdong Province
Manufacturer.....: GUANG TAI ENTERPRISE CO.,LTD.
Address.....: No. 2, Dapianmei District, Dalingshan Town, Dongguan City, Guangdong Province
Product Name.....: Furniture power Distribution Unit
Model(s) JN02-00-112, JN02-00-111, JN02-00-211, JN02-00-22, JN02-00-113, JN02-00-213, JN02-00-113K, JN02-00-21, JN02-00-23, JN02-00-212
Trademark.....: N/A
Test Standard.....: EN 55032: 2015/A1: 2020;
EN IEC 61000-3-2: 2019/A2: 2024;
EN 61000-3-3:2013+A2:2021;
EN 55035:2017/A11:2020.
Directives.....: EMC Directive 2014/30/EU
Report Number..: LCT-250803286238

Remark:

The tests were performed in normal operation mode, the test results apply only to the particular sample tested and to the specific tests carried out. This certificate applies specifically to the sample investigated in our test reference number only.

The CE markings as shown below can be affixed on the product after preparation of necessary technical documentation.

Other relevant Directives have to be observed.



(Manager)

Aug. 26, 2025

Declaration of Conformity

This declaration of conformity is issued under the sole responsibility of the manufacturer.

Manufacturer: GUANG TAI ENTERPRISE CO.,LTD.

Address:No. 2, Dapianmei District, Dalingshan Town, Dongguan City,Guangdong Province

Sample Name: Furniture power Distribution Unit

Main Model: JN02-00-112

SeriesModels:JN02-00-111,JN02-00-211,JN02-00-22,JN02-00-113,JN02-00-213,JN02-00-113K,JN02-00-213K,JN02-00-213L,JN02-00-213M,JN02-00-213N,JN02-00-213O,JN02-00-213P,JN02-00-213Q,JN02-00-213R,JN02-00-213S,JN02-00-213T,JN02-00-213U,JN02-00-213V,JN02-00-213W,JN02-00-213X,JN02-00-213Y,JN02-00-213Z

Parameters:

Input:AC220-250V,1.6A,50Hz,MAX.3680W

USB-A:5V DC 2.1A,10.5W

USB-C:5VDC 2.1A,10.5W

USB-A+USB-C:5VDC 2.1A,10.5W

This declaration is issued under the sole responsibility of the Manufacturer

The object of the declaration described above is in conformity with the relevant Union harmonisation legislation:

Conformity is shown by compliance with the applicable requirements of the following documents:

Reference & Date	Title
IEC 62368-1:2023 EN IEC 62368-1: 2024 +A11:2024	LVD Directive 2014/35/EU
IEC 60884-1:2002 IEC 60884-1:2002/AMD1:2006 IEC 60884-1:2002/AMD2:2013 IEC 60884-2-7:2011 IEC 60884-2-7:2011/AMD1:2013	

the declaration of conformity is issued under the sole responsibility of the Manufacturer.

Sien on behalf of: GUANG TAI ENTERPRISE CO.,LTD.

Position:Manager

Name: Yang Zhongping

Place: No. 2, Dapianmei District, Dalingshan Town, Dongguan City,Guangdong Province

Sample Name: Furniture power Distribution Unit

Date:August 19, 2025

Signature: _____