

N883P459761W

N883P459762W

DE:Installationsanleitung

UK:Installation Instruction

FR:Instruction d'installation

IT:Istruzioni di installazione

ES: Instrucciones de instalaci

NL: Installatie-instructies

SE: Installationsanvisningar

PL: Instrukcje instalacj

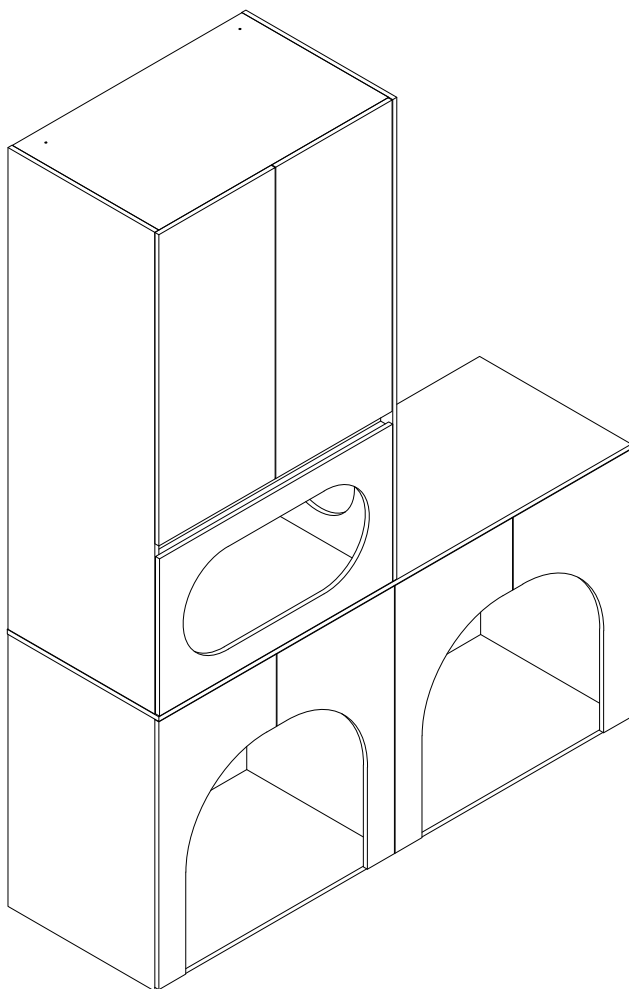

DE: Unser Produkt wird Ihnen in 2 Paketen geliefert. Die Lieferzeiten dieser 2 Pakete können abweichen, bitte haben Sie etwas Geduld und vielen Dank für Ihr Verständnis.

UK: Our product will be delivered to you in 2 packages. The delivery times of these 2 packages may differ, please be patient and thank you for your understanding.

FR: Notre produit vous sera livré en 2 colis. Les délais de livraison de ces 2 colis peuvent différer, soyez patient et merci pour votre compréhension.

IT: Il nostro prodotto verrà consegnato in 2 pacchi. I tempi di consegna di questi 2 pacchi possono variare; vi preghiamo di avere un po' di pazienza e vi ringraziamo per la vostra comprensione.

ES: Nuestro producto se entregará en 2 paquetes. Los tiempos de entrega de estos 2 paquetes pueden variar; por favor, tenga un poco de paciencia y gracias por su comprensión.

NL: Ons product wordt in 2 pakketten bij u geleverd. De levertijden van deze 2 pakketten kunnen verschillen, we vragen om uw geduld en bedanken u voor uw begrip.

SE: Vår produkt kommer att levereras till dig i 2 paket. Leveranstiderna för dessa 2 paket kan variera, vi ber om ditt tålamod och tackar för din förståelse.

PL: Nasz produkt zostanie dostarczony w 2 paczkach. Czas dostawy tych 2 paczek może się różnić, prosimy o cierpliwość i dziękujemy za zrozumienie.

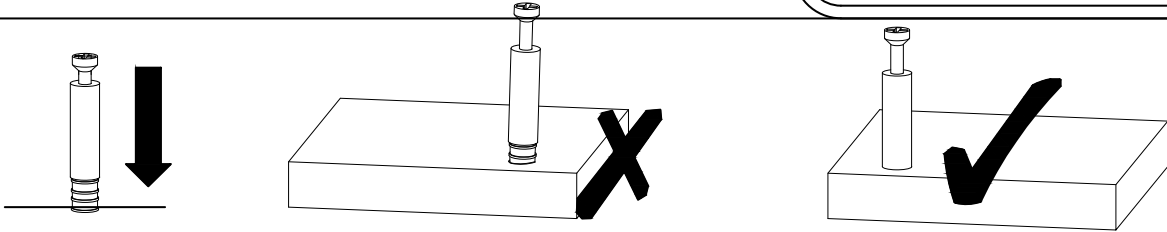

EN_Q4ICKFIT:Tighten quickfit until shoulder is flush with panel.Do not overtighten or undertighten
 FR_RACCORD RAPIDE:Faites serrer le raccord rapide jusqu'à ce que l'épaulement soit parfaitement encastré dans le panneau. Il ne faut ni trop serrer ni insuffisamment serrer.
 ES_QUICKFIT:Apriete quickfit hasta que el hombro se descargue con el panel. NO lo sobreapriete nilo apriete poco.
 DE_QUICKFIT:Ziehen Sie den Quickfit fest, bis die Schulter mit der Platte bundig ist. Bite nicht zu fest oderzu schwach anziehen.
 IT_MONTAGGIO RAPIDO:Stringere il montaggio rapido fino a quando la spalla è a filo con il pannello,non stringere troppo o troppo poco.

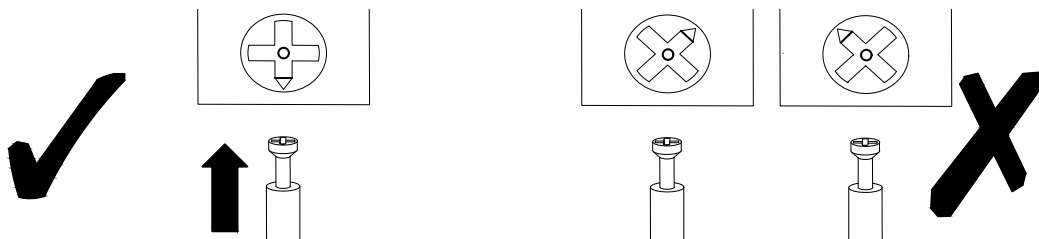

EN_CAM LOCK:When fitting cam lock, ensure starting position is correct before you insert connecting quickfit.
 FR_SERRURE BATTEUSE:Avant d'insérer la serrure batteuse, veillez à la bonne orientation avant d'insérerle raccord rapide.
 ES_CIERRE DE LA CAMARA:Cuando instale el cierre de la cámara, asegurese de que la posición de inicio es correcta antes de que inserte el quickfit conector.
 DE_CAM-LOCK:Achten Sie bei der Montage des Cam-Locks aufdie richtige Ausgangsposition. bevor Sie den Quickfit einsetzen.
 IT_BLOCCAGGIOACAMMA:Quando si monta il bloccaggio a camma, assicurarsi che la posizione iniziale sia corretta prima di inserire il montaggio rapido di callegamento.

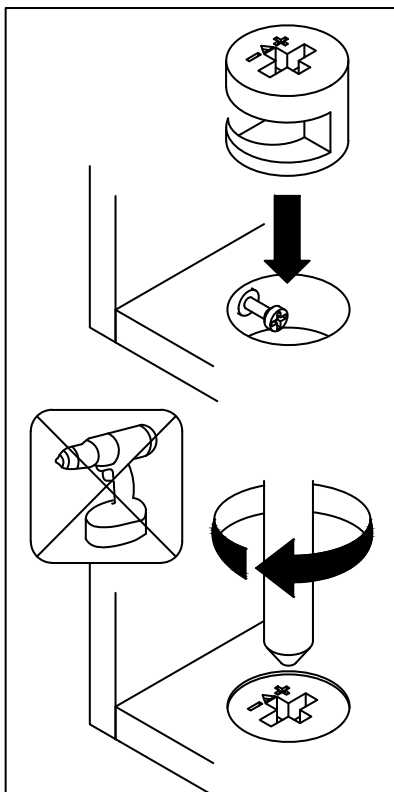

EN_Quickfit head should be in the centre of the cam lock when the two panels are joined.
 Camlock should be inserted before quickfit.
 FR_Lorsque les deux panneaux sont assemblés,la tête du raccord rapide doitreposer au centre de la serrure batteuse.
 Il fautinsérerla serrure batteuse avant le raccord rapide.
 ES_El cabezal del quickfit debe estar en el centro del cierre de la cámara cuando se unan los dos paneles.
 Se debe insertarel cierre de la camara antes que el quickfit.
 Afechadura de cames deve ser inserida antes de ser rápida
 DE_DerQuickfit-Kopf sollte sich in der Mitte des Cam-Locks befinden. wenn die beiden Platten zusammengefügt sind.
 Der Cam-Lock sollte vor dem Quickfit eingesetzt werden.
 IT_La testa del montaggio rapido deve trovarsi al centro del bloccaggio a cammaquando i due pannelli sono uniti.
 Il Bloccaggio a Camma deve essere inserito prima del montaggio rapido

EN_Turn cam lock clockwise to tighten.
 FR_Faites tournerla serrure batteuse dans le sens des aiguilles d'une montre pourla resserrer.
 ES_Gire el cierre de la cámara en sentido horario para apretarlo.
 DE_Drehen Sie den Cam-Lockim Uhrzeigersinn, um ihn fesfzuziehen.
 IT_Ruotareil bloccaggio a camma in senso orario per stringere.

EN It may be necessary to adjust the hinges so that the doors align. Use the instructions below as a guide.

FR Il est parfois nécessaire d'ajuster les charnières pour un meilleur alignement des portes. Servez-vous des instructions ci-dessous comme guide.

ES Puede que sea necesario ajustar los quicios de forma que se alineen las puertas. Use las instrucciones que aparecen debajo como guía.

DE Möglicherweise müssen Sie die Scharniere so einstellen, dass die Türen ausgerichtet sind. Verwenden Sie die nachstehenden Anweisungen als Leitfaden.

IT Potrebbe essere necessario regolare le cerniere in modo che le porte siano allineate. Per fare ciò attenersi alle istruzioni sottostanti.

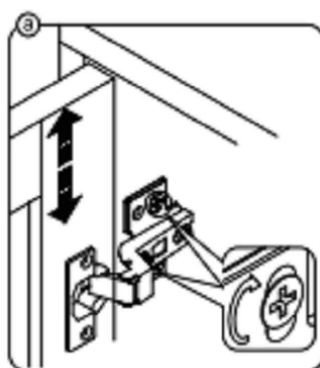

EN To adjust the door vertically loosen the screw as shown and move up and down as needed.

FR Si vous souhaitez régler la porte **verticalement**, desserrez la vis comme indiqué et déplacez la porte de haut en bas selon les besoins.

ES Para ajustar la puerta **verticalmente** afloje el tornillo tal y como se muestra y muévelo hacia arriba o hacia abajo según sea necesario.

DE Um die Tür **vertikal** auszurichten, lösen Sie die Schraube wie abgebildet und bewegen Sie sie nach Bedarf nach oben oder nach unten.

IT Per allineare la porta **verticalmente** allentare la vite come mostrato e spostarla in alto o in basso secondo necessità.

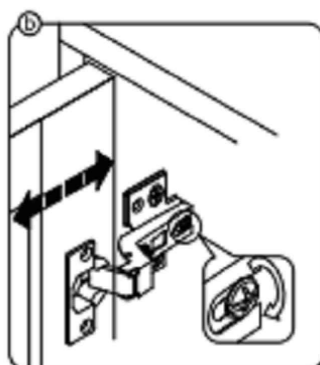

EN To adjust the gap from the door to the main frame turn the screw clockwise or anti-clockwise as needed.

FR Si vous souhaitez ajuster l'**écart** entre la porte et le cadre principal, tournez la vis dans le sens des aiguilles d'une montre ou dans le sens inverse, si nécessaire.

ES Para ajustar el **espacio** desde la puerta al marco principal, gire el tornillo en sentido horario o antihorario, según se necesite.

DE Um den **Abstand** von der Tür zum Hauptrahmen auszurichten, drehen Sie die Schraube je nach Bedarf im oder gegen den Uhrzeigersinn.

IT Per regolare lo **spazio** tra la porta e il telaio principale, avvitare o svitare la vite secondo necessità.

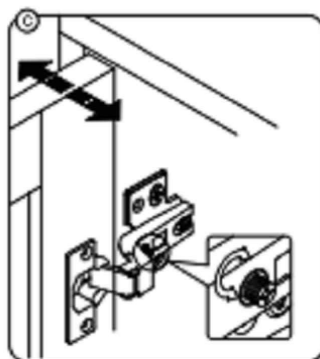

EN To adjust the door laterally adjust the screw as shown by turning clockwise or anti-clockwise.

FR Si vous souhaitez ajuster la porte **latéralement**, ajustez la vis comme indiqué en tournant dans le sens des aiguilles d'une montre ou dans le sens inverse des aiguilles d'une montre.

ES Para ajustar la puerta **lateralmente** ajuste el tornillo tal y como se muestra girándolo en sentido horario y antihorario.

DE Um die Tür **seitlich** auszurichten, stellen Sie bitte die Schraube wie abgebildet durch Drehen im oder gegen den Uhrzeigersinn ein.

IT Per allineare la porta **lateralmente** regolare la vite come mostrato, avvitandola o svitandola.

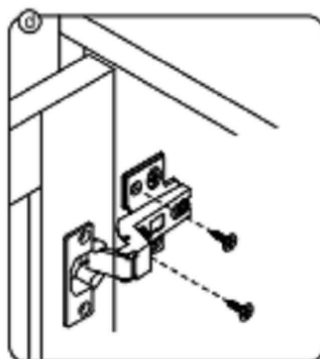

EN Please fix other screws

FR Merci de serrer les autres vis.

ES Fije los demás tornillos

DE Befestigen Sie bitte die anderen Schrauben

IT Fissare le altre viti



DE

Warnung: Die maximale Belastbarkeit dieses Möbels beträgt:
60kg, bitte nicht überlasten!

EN

Warning: The maximum load-bearing capacity of this furniture is:
60kg, please do not overload!

FR

Avertissement : La capacité de charge maximale de ce meuble
est de :

60kg, merci de ne pas surcharger !

IT

Attenzione: la capacità di carico massima di questo mobile è:
60kg, non sovraccaricare!

ES

Advertencia: La capacidad máxima de carga de este mueble es:
60kg, no lo sobrecargue!

DE: Vordem Einbaudie Schrauben in die L?cher stecken und festziehen, aber nicht bis 100%, 70% bis 80% anziehen reicht aus. Schließlich, nachdem alle Schrauben installiert sind, ziehen Sie alle Schrauben auf 100%. Wenn Sie auf diese Probleme sto?en, wie z. B. Fehlausrichtung der L?cher oder Unf?higkeit, bestimmte Teile zu installieren, ?berpr?fen Sie bitte, ob die Schrauben korrekt verwendet werden und passen Sie die Dichtigkeit der Schrauben an.

UK: Before installation, insert the screws into the holes and tighten them, but do not tighten them to 100%, 70% to 80% is sufficient. Finally, after all screws are installed, tighten all screws to 100%.

If you encounter these issues, such as if the holes cannot be aligned or some parts cannot be installed, please check if the screws are used correctly and adjust the tightness of the screws.

FR: Ins?rer la vis dans le trou avant la fin de l'assemblage, serrer la vis, mais ne pas serrer ? 100%, 70% ~ 80% est correct. Enfin, une fois que toutes les vis sont bien serr?es, toutes les vis sont serr?es ? 100%.

Si vous rencontrez ces probl?mes, par exemple si les trous ne sont pas align?s ou si certaines pi?ces ne peuvent pas ?tre mont?es, v?rifiez que les vis sont utilis?es correctement et ajustez leur serrage.

IT: Prima dell'installazione, inserire le viti nei fori stringerle, ma non al 100%, ? sufficiente stringerle al 70%-80%. Infine, dopo aver installato tutte le viti, stringere tutte le viti al 100%. Se riscontri problemi come disallineamento dei fori o difficolt? nell'installare alcuni componenti, verifica che le viti siano utilizzate correttamente e regola la tensione delle viti.

ES: Antes de la instalación, coloque los tornillos en los agujeros y apriete los, pero no al 100%; apriete al 70%-80% es suficiente.

Finalmente, después de haber instalado todos los tornillos, apriete todos los tornillos al 100%. Si se encuentra con problemas como desalineación de los agujeros o dificultad para instalar ciertas piezas, verifique que los tornillos se estén utilizando correctamente y ajuste la tensión de los tornillos.

NL: Voordat u begint met de installatie, plaatst u de schroeven in de gaten en draait u ze aan, maar draai ze niet volledig aan; 70% tot 80% is voldoende. Draai uiteindelijk, nadat alles schroeven zijn geplaatst, alle schroeven volledig aan. Als u problemen ondervindt, zoals niet uitgelijnde gaten of onderdelen die niet kunnen worden geïnstalleerd, controleer dan of de schroeven correct zijn gebruikt en pas de spanning van de schroeven aan.

SE: Innan installation, sätta skruvarna i hålen och dra åt dem, men dra inte åt dem helt; 70% till 80% räcker. Slutligen, när alla skruvar är installerade, dra åt alla skruvar helt. Om du stöter på ett problem, som att hålen inte kan justeras eller vissa delar inte kan installeras, kontrollera om skruvarna använts korrekt och justera skruvarna sättdragning.

PL: Przed instalacją wstaw śruby w otwory i dokręć je, ale nie dokręcaj ich na 100%; 70% do 80% wystarczy. Na koniec, po zainstalowaniu wszystkich śrub, dokręć wszystkie śruby do 100%. Jeśli napotkasz problemy, takie jak niepasujące otwory lub części, które nie mogą być zainstalowane, sprawdź, czy śruby są używane prawidłowo i dostosuj ich dokręcenie.



[DE]

Warnung: Lesen Sie die Anleitung vor dem Zusammenbau bitte vollständig durch. Überprüfen Sie, ob Sie alle auf den Seiten aufgeführten Komponenten und Werkzeuge haben.

Warnung: Legen Sie alle Teile auf eine ebene Fläche. Legen Sie eine weiche Decke oder Ähnliches darunter, um sie vor Kratzern oder Flecken zu schützen. Vermeiden Sie es, Komponenten über den Boden zu ziehen oder zu schieben.

Warnung: Überprüfen Sie regelmäßig alle Beschläge und Befestigungen, um sicherzustellen, dass sie sicher sind und um Unfälle zu vermeiden. Wenn Teile fehlen, kaputt, beschädigt oder abgenutzt sind, verwenden Sie das Produkt nicht weiter, bis es mit vom Hersteller autorisierten Teilen repariert wurde.

Warnung: Lassen Sie Kinder nicht auf die Möbel klettern, da dies zum Umkippen und zu schweren Verletzungen führen kann. Bauen Sie die Möbel außerhalb der Reichweite von Kindern zusammen.

Warnung: Stellen Sie die Möbel nicht in die Nähe von Feuerquellen oder heißen Gegenständen, um Brandgefahr zu vermeiden.

Warnung: Reinigen Sie die Möbel mit einem feuchten Tuch oder Alkohol. Verwenden Sie keine Reinigungsmittel mit ätzenden Chemikalien.

Warnung: Dieses Produkt ist mit einer Kippschutzvorrichtung ausgestattet. Bitte installieren Sie diese Vorrichtung unbedingt, um unnötige Verletzungen durch Umkippen zu vermeiden.

[EN]

Warning: Please read instructions fully before starting assembly. Check you have all the components and tools listed on pages.

Warning: Please place all parts on a flat surface. Place a soft blanket or similar underneath to protect against scratches or stains. Avoid dragging or sliding components across the floor.

Warning: Regularly check all fittings and fastenings to ensure they are secure and to prevent accidents. If any parts are missing, broken, damaged, or worn, discontinue use of the product until repairs have been made using factory authorized parts.

Warning: Do not allow children to climb on the furniture as this may result in tipping and serious personal injury. Assemble the furniture away from the reach of children.

Warning: Do not place furniture close to fire sources or high-temperature objects to avoid the risk of fire.

Warning: Clean furniture with a damp cloth or alcohol, avoid using cleaning agents containing corrosive chemicals.

Warning: This product is equipped with an anti-tilt device. Please be sure to install this device to prevent unnecessary injuries caused by tipping.

[FR]

Avertissement : Veuillez lire entièrement les instructions avant de commencer l'assemblage. Vérifiez que vous disposez de tous les composants et outils répertoriés sur les pages.

Avertissement : Veuillez placer toutes les pièces sur une surface plane. Placez une couverture douce ou similaire en dessous pour les protéger des rayures ou des taches. Évitez de faire glisser les composants sur le sol.

Avertissement : Vérifiez régulièrement tous les raccords et fixations pour vous assurer qu'ils sont bien fixés et pour éviter les accidents. Si des pièces manquent, sont cassées, endommagées ou usées, cessez d'utiliser le produit jusqu'à ce que des réparations aient été effectuées à l'aide de pièces autorisées par l'usine.

Avertissement : Ne laissez pas les enfants grimper sur les meubles car cela pourrait entraîner un basculement et des blessures graves. Assemblez les meubles hors de portée des enfants.

Avertissement : Ne placez pas les meubles à proximité de sources de feu ou d'objets à haute température pour éviter tout risque d'incendie.



Avertissement : Nettoyez les meubles avec un chiffon humide ou de l'alcool, évitez d'utiliser des produits de nettoyage contenant des produits chimiques corrosifs.

Avertissement : Ce produit est équipé d'un dispositif anti-basculement. Assurez-vous d'installer ce dispositif pour éviter les blessures inutiles causées par un basculement.

[IT]

Attenzione: leggere attentamente le istruzioni prima di iniziare il montaggio. Verificare di avere tutti i componenti e gli strumenti elencati nelle pagine.

Attenzione: posizionare tutte le parti su una superficie piana. Posizionare una coperta morbida o simile sotto per proteggere da graffi o macchie. Evitare di trascinare o far scivolare i componenti sul pavimento.

Attenzione: controllare regolarmente tutti i raccordi e i dispositivi di fissaggio per assicurarsi che siano sicuri e per prevenire incidenti. Se alcune parti sono mancanti, rotte, danneggiate o usurate, interrompere l'uso del prodotto fino a quando non siano state eseguite le riparazioni utilizzando parti autorizzate dalla fabbrica.

Attenzione: non consentire ai bambini di arrampicarsi sui mobili poiché ciò potrebbe causare ribaltamenti e gravi lesioni personali. Montare i mobili lontano dalla portata dei bambini.

Attenzione: non posizionare i mobili vicino a fonti di fuoco o oggetti ad alta temperatura per evitare il rischio di incendio.

Attenzione: pulire i mobili con un panno umido o alcol, evitare di utilizzare detergenti contenenti sostanze chimiche corrosive.

Attenzione: questo prodotto è dotato di un dispositivo antiribaltamento. Assicurarsi di installare questo dispositivo per prevenire lesioni inutili causate dal ribaltamento.

[ES]

Advertencia: Lea las instrucciones completamente antes de comenzar el montaje. Compruebe que tiene todos los componentes y herramientas que se enumeran en las páginas.

Advertencia: Coloque todas las piezas sobre una superficie plana. Coloque una manta suave o algo similar debajo para protegerlas de rayones o manchas. Evite arrastrar o deslizar los componentes por el piso.

Advertencia: Verifique regularmente todos los accesorios y fijaciones para asegurarse de que estén seguros y evitar accidentes. Si falta alguna pieza, está rota, dañada o desgastada, deje de usar el producto hasta que se hayan realizado las reparaciones con piezas autorizadas de fábrica.

Advertencia: No permita que los niños se suban a los muebles, ya que esto puede provocar que se vuelquen y lesiones personales graves. Monte los muebles fuera del alcance de los niños.

Advertencia: No coloque los muebles cerca de fuentes de fuego u objetos de alta temperatura para evitar el riesgo de incendio.

Advertencia: Limpie los muebles con un paño húmedo o alcohol, evite usar agentes de limpieza que contengan químicos corrosivos.

Advertencia: Este producto está equipado con un dispositivo antivuelco. Asegúrese de instalar este dispositivo para evitar lesiones innecesarias causadas por vuelcos.

Importeur	Decobus Handel GmbH
Adresse	Innungsstraße 9, 21244 Buchholz, Deutschland
URL	https://www.decobusgroup.de
Hersteller	Sichuan Rongshang Yuncheng International Trade Co., Ltd.
Adresse	Suite 1720, 17th Floor, Unit 1, Building 9, No. 1700, North Section of Tianfu Avenue, Chengdu High-Tech Zone, China (Sichuan) Pilot Free Trade Zone, Chengdu, Sichuan, China
Email/URL	jingluck9925@qq.com



Decobus Handel GmbH

Innungsstraße 9,

21244 Buchholz, Deutschland

<https://www.decobusgroup.de>

EN

Dear customer,

Thank you for purchasing this product. So that your appliance serves you well, please read **all** the instructions in this user's manual. If you have any questions, please contact our customer care center.

FR

Cher client,

Nous vous remercions d'avoir acheté ce produit. Afin que vous puissiez profiter pleinement de votre appareil, veuillez lire toutes les instructions de ce manuel d'utilisation. Si vous avez la moindre question, veuillez contacter notre centre d'assistance à la clientèle.

DE

Sehr geehrter Kunde,

Vielen Dank, dass Sie dieses Produkt erworben haben. Damit Ihr Gerät Ihnen gute Dienste leistet, lesen Sie bitte alle Hinweise in diesem Benutzerhandbuch. Wenn Sie Fragen haben, wenden Sie sich bitte an unser Kundendienstzentrum.

ES

Queridos clientes,

Gracias por comprar este producto. Para que su electrodoméstico le sirva mejor, lea todas las instrucciones de este manual del usuario. Si tiene alguna pregunta, comuníquese con nuestro Centro de Atención al Cliente.

IT

Caro Cliente,

Grazie per aver acquistato questo prodotto. Per servirti meglio con questo apparecchio ti prego di leggere tutte le istruzioni in presente manuale utente. In caso di dubbio, si prega di contattare il nostro centro assistenza clienti.

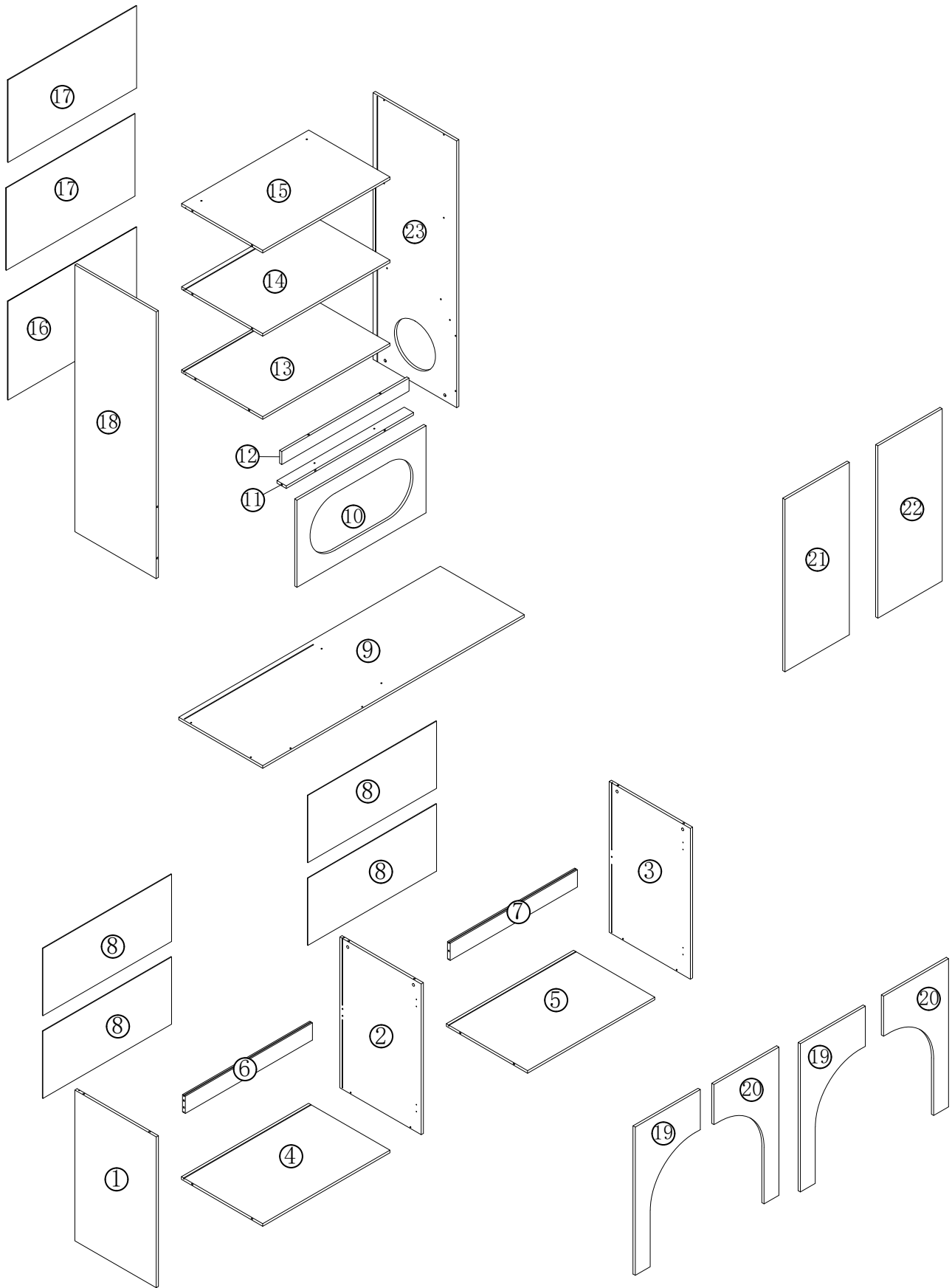

N883P459761W

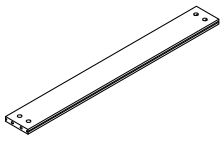
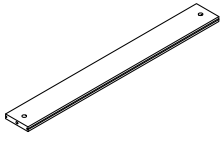
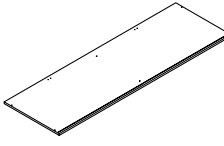
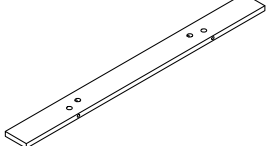
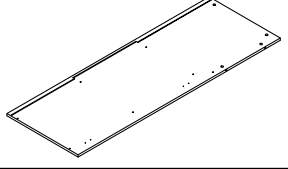
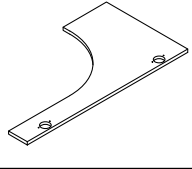
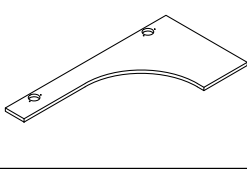
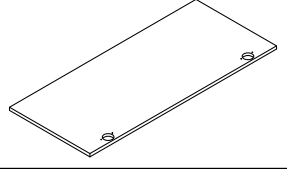
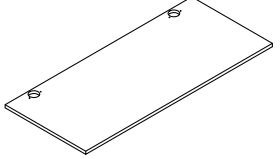
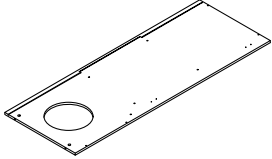
			
⑥ x1pc	⑦ x1pc	⑨ x1pc	⑫ x1pc
			
⑱ x1pc	⑲ x2pcs	⑳ x2pcs	㉑ x1pc
			
㉒ x1pc	㉓ x1pc		

N883P459762W

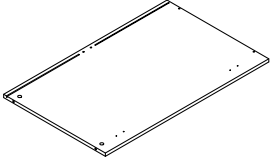
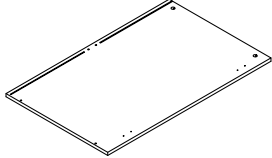
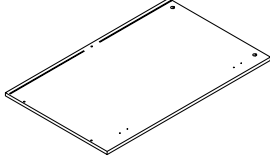
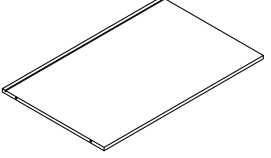
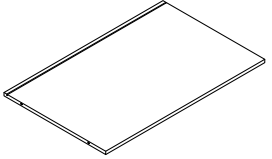
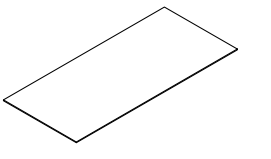
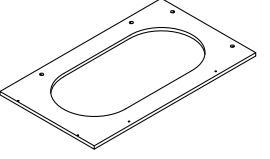
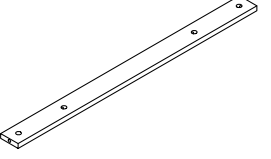
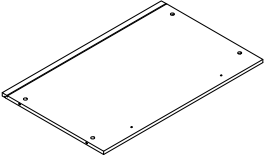
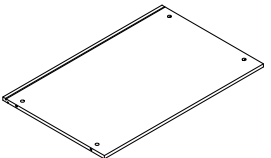
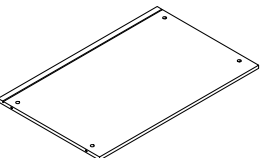
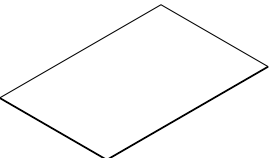
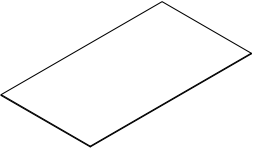
			
① x1pc	② x1pc	③ x1pc	④ x1pc
			
⑤ x1pc	⑧ x4pcs	⑩ x1pc	⑪ x1pc
			
⑬ x1pc	⑭ x1pc	⑮ x1pc	⑯ x1pc
			
⑰ x2pcs			

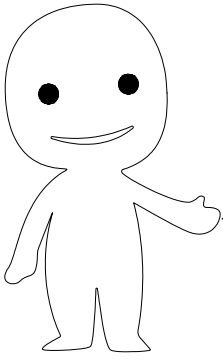

Please prepare the following tools

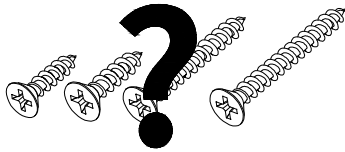
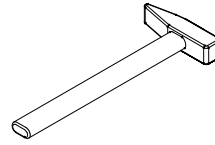
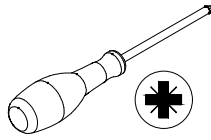

When installing, please carefully confirm whether each screw corresponds to the manual, accessories with similar shapes can be distinguished by size



Lors de l'installation, veuillez vérifier soigneusement si chaque vis correspond au manuel. Les accessoires de forme similaire peuvent être distingués par leur taille.

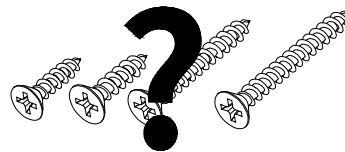

Prüfen Sie bei der Installation sorgfältig, ob jede Schraube mit der Anleitung übereinstimmt, Zubehör mit ähnlichen Formen kann anhand der Größe unterschieden werden.

N883P459762W

A x 50+3

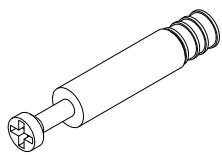

M6*34mm

B x 50+3



∅12*9mm

C x 76+2

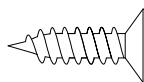

M3.5*12mm

D x 4

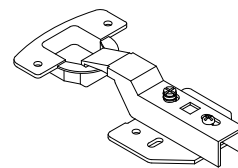

E x 6

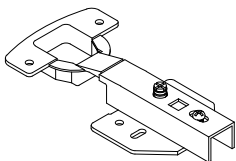

F x 50



G x 2

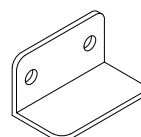

H x 2

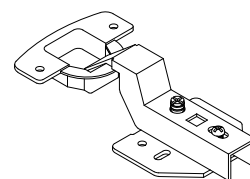

I x 42

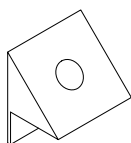

J x 44+2

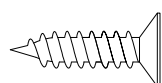

M3.5*14mm

K x 6

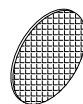

∅12*2mm

L x 2

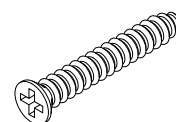

M4*30mm

M x 2

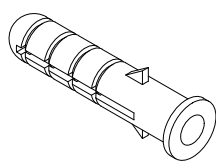

N x 2

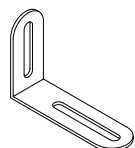

O x 1

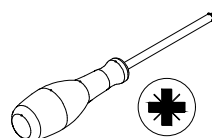

1

A x 7

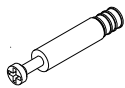

M6*34mm

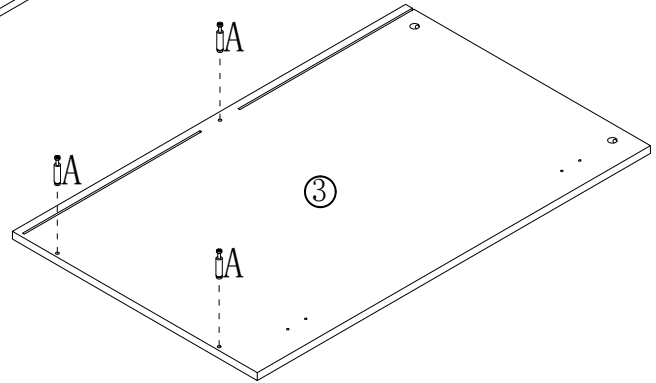
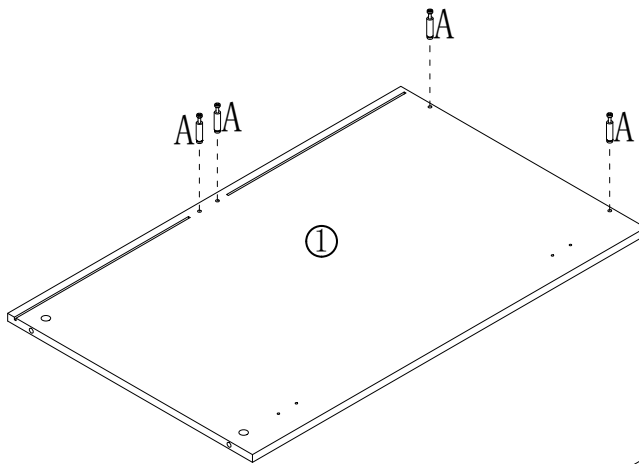
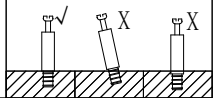
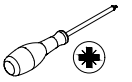

2

A x 7

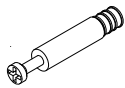

M6*34mm

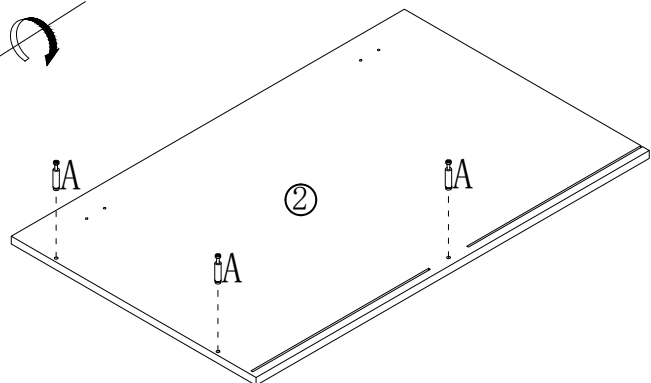
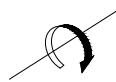
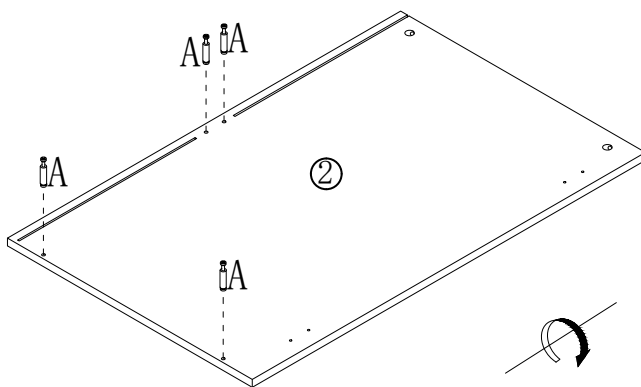
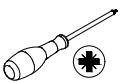

3

B x 4



φ12*9mm

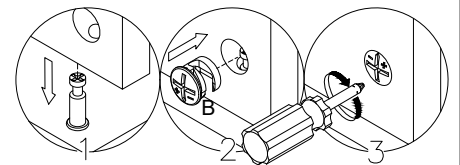
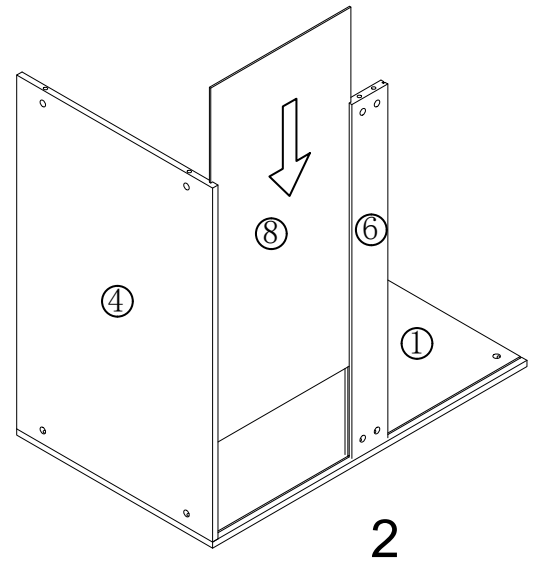
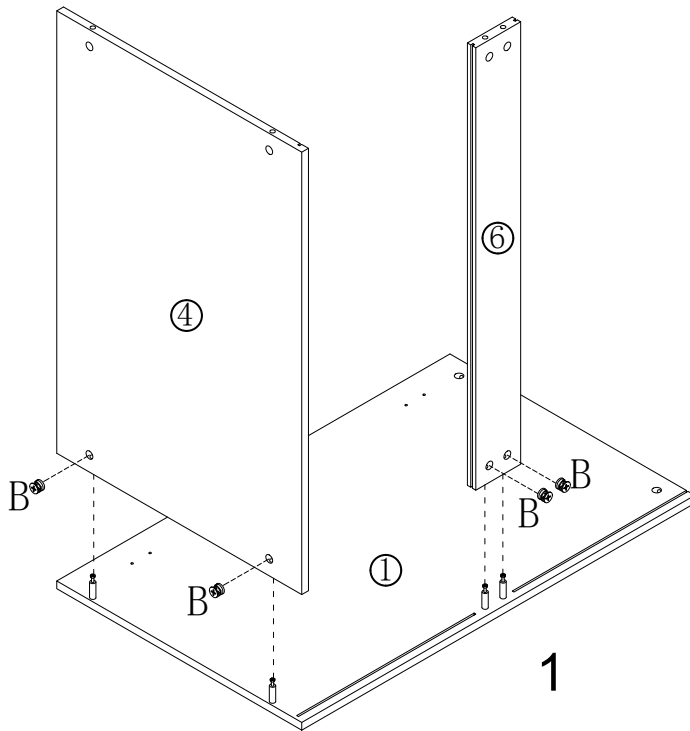
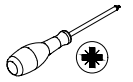

4

B x 4



φ12*9mm

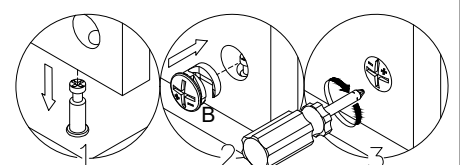
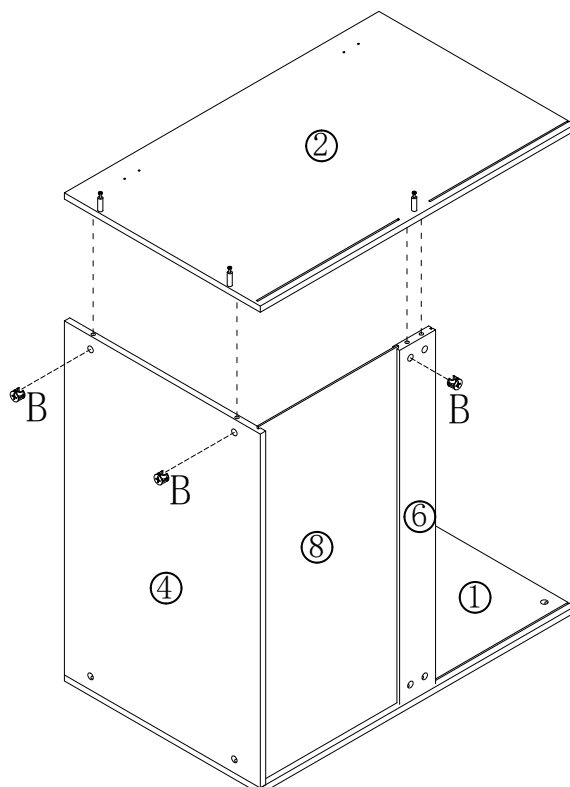
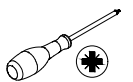

5

B x 3



φ12*9mm

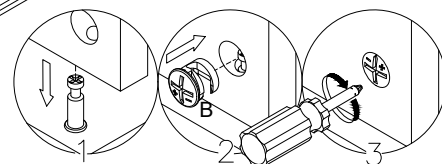
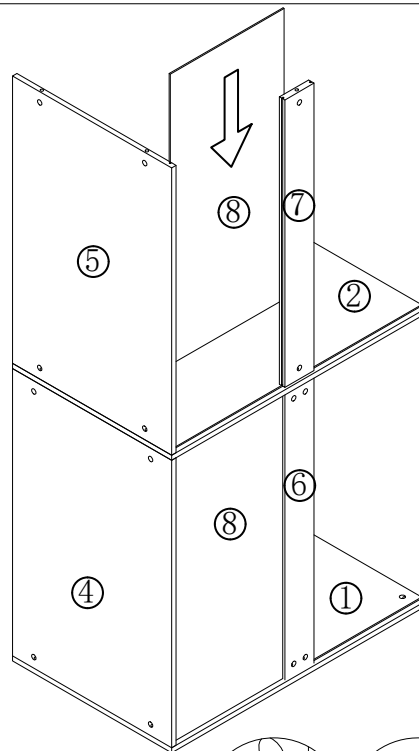
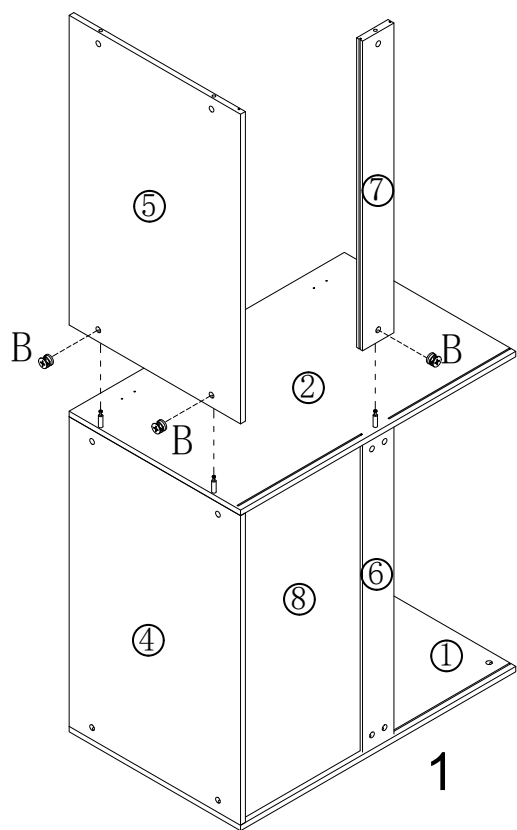

6

B x 3



φ12*9mm

K x 6



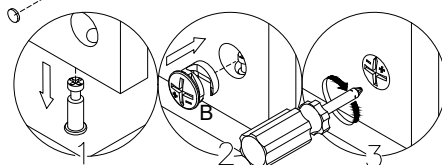
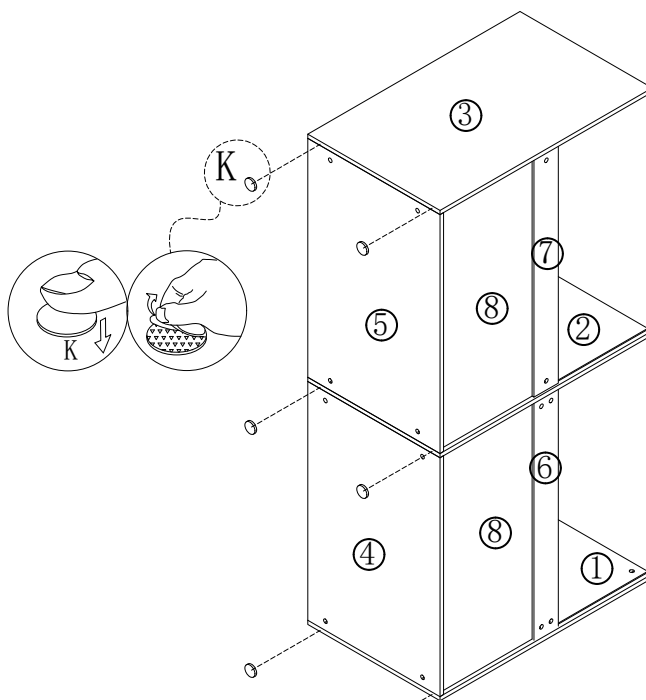
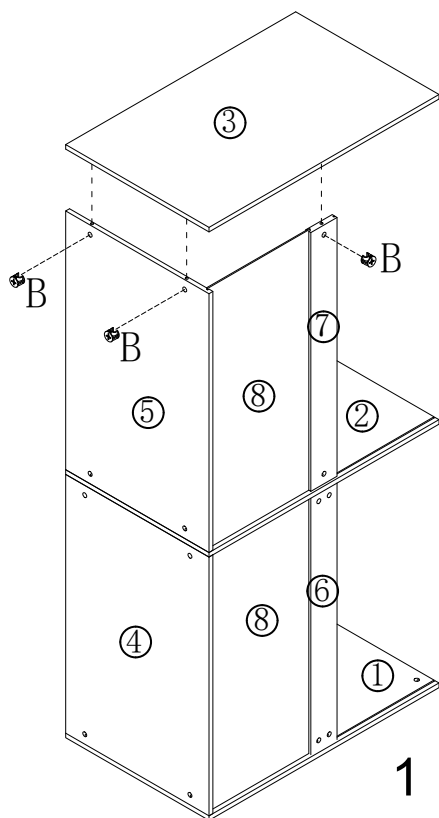

φ12*2mm

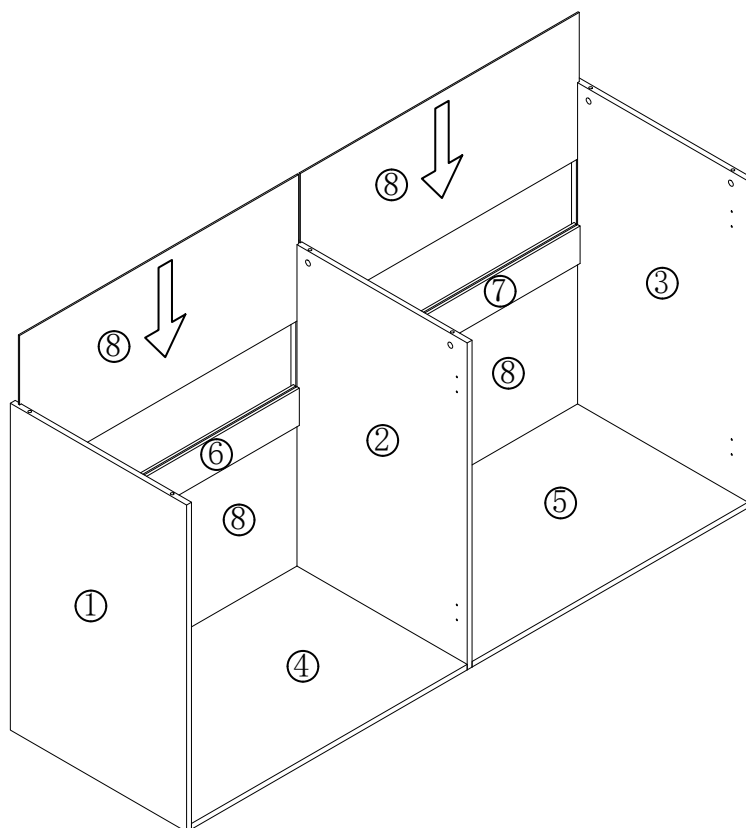

7

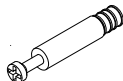

8

A x 12	G x 2	C x 4
 M6*34mm		

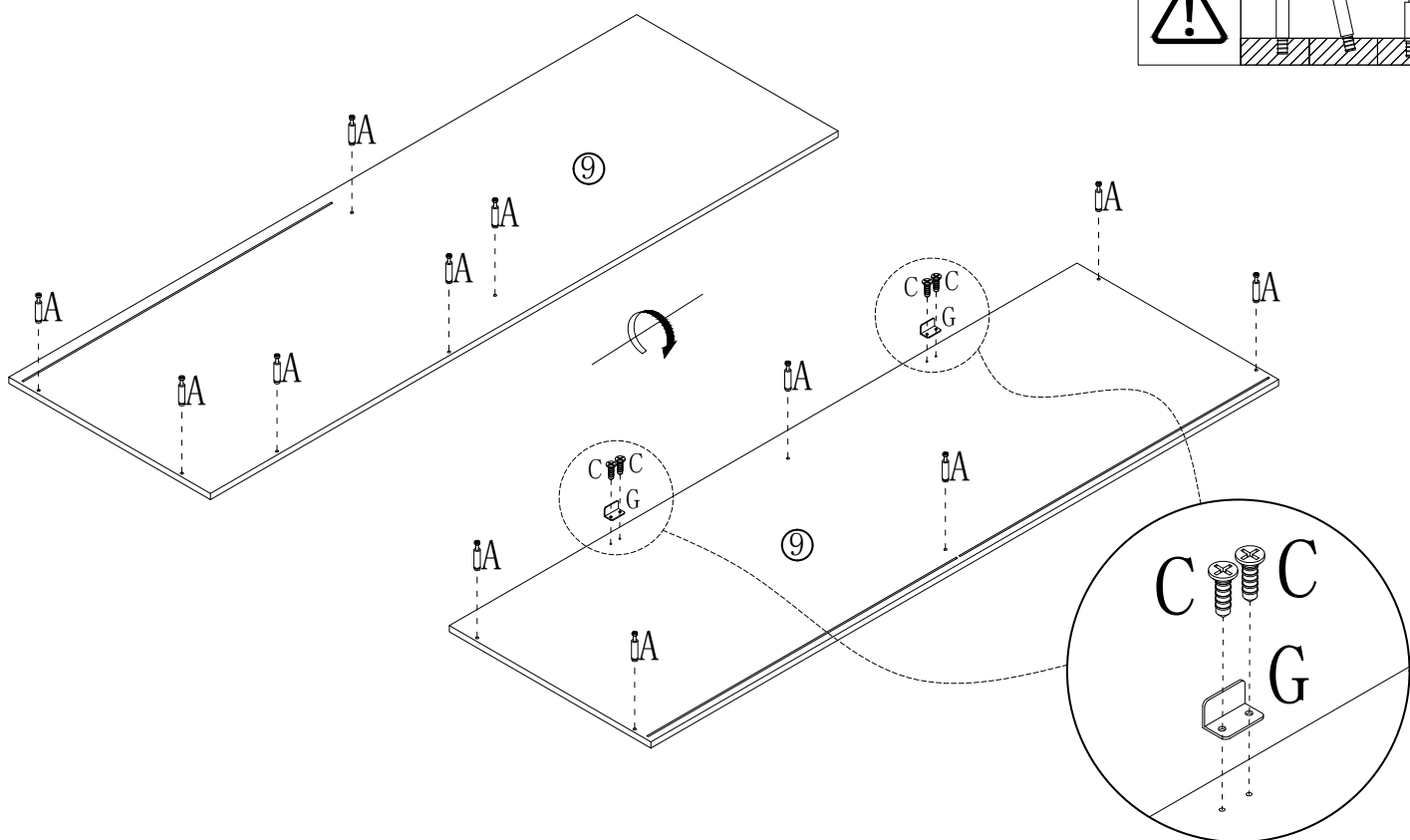
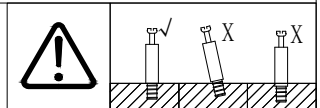
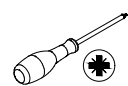

9

A x 8

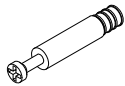

M6*34mm

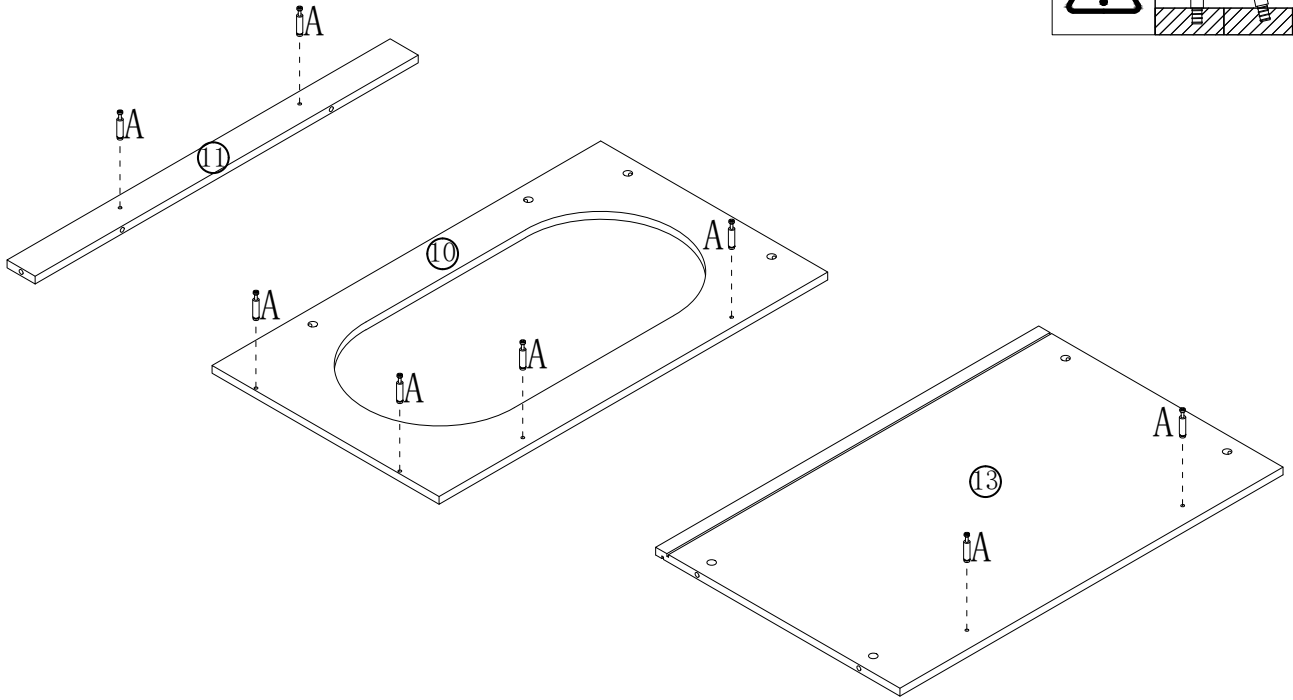
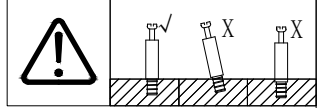
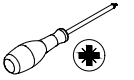

10

A x 16

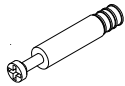

M6*34mm

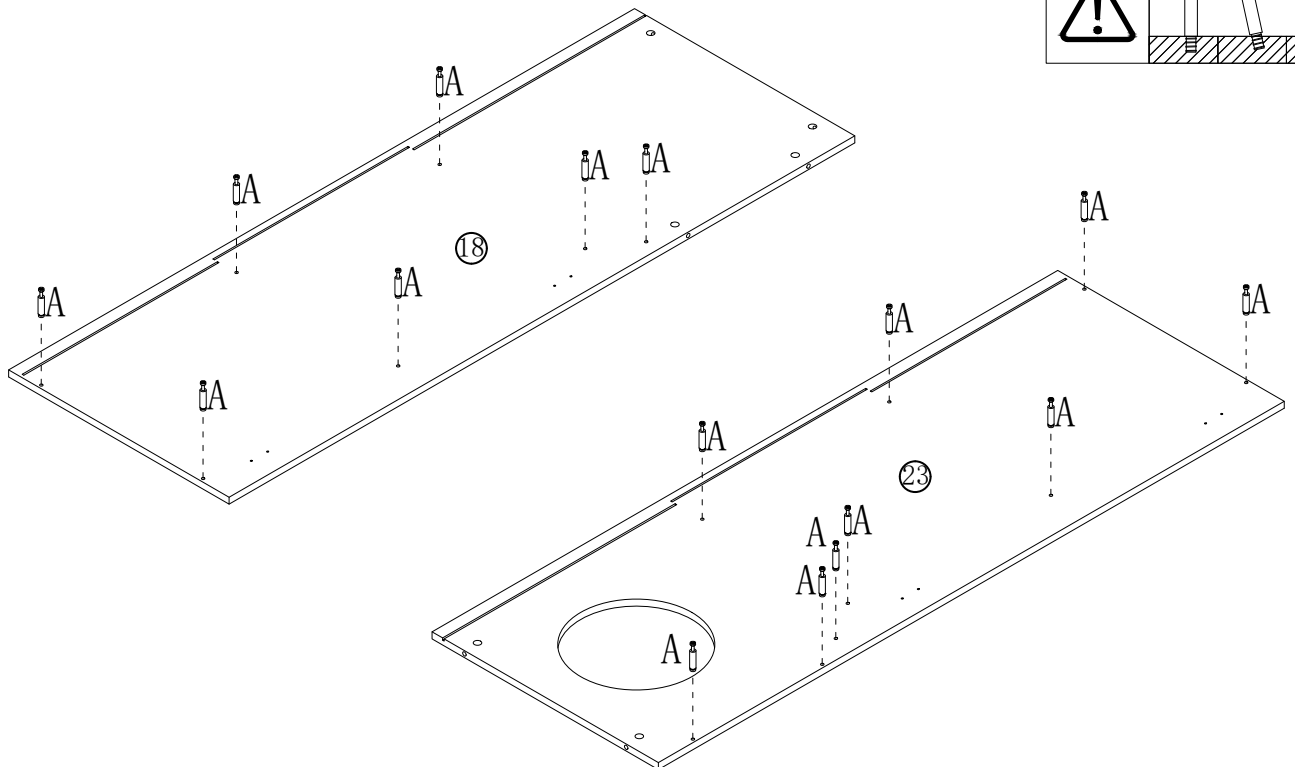
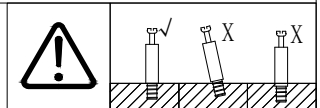
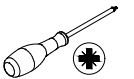

11

B x 4



φ12*9mm

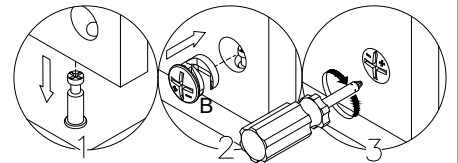
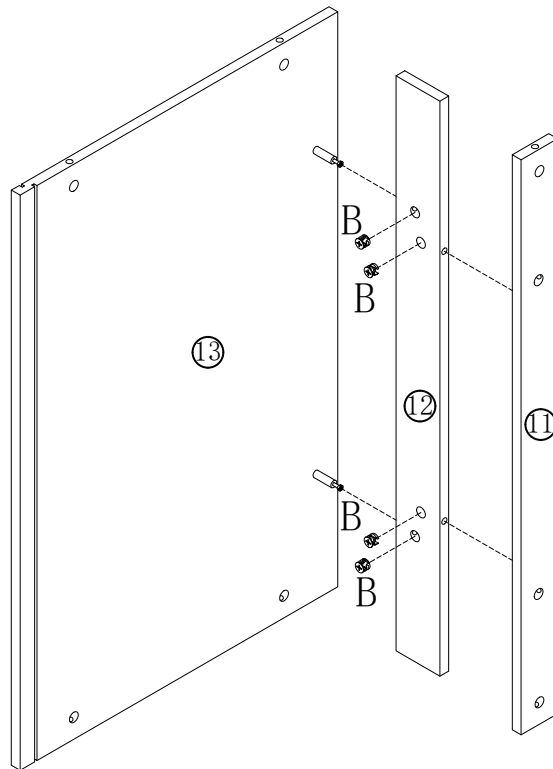
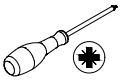

12

B x 3



φ12*9mm

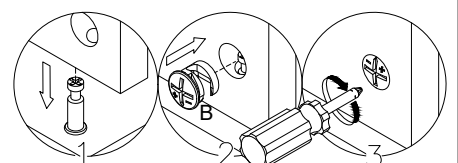
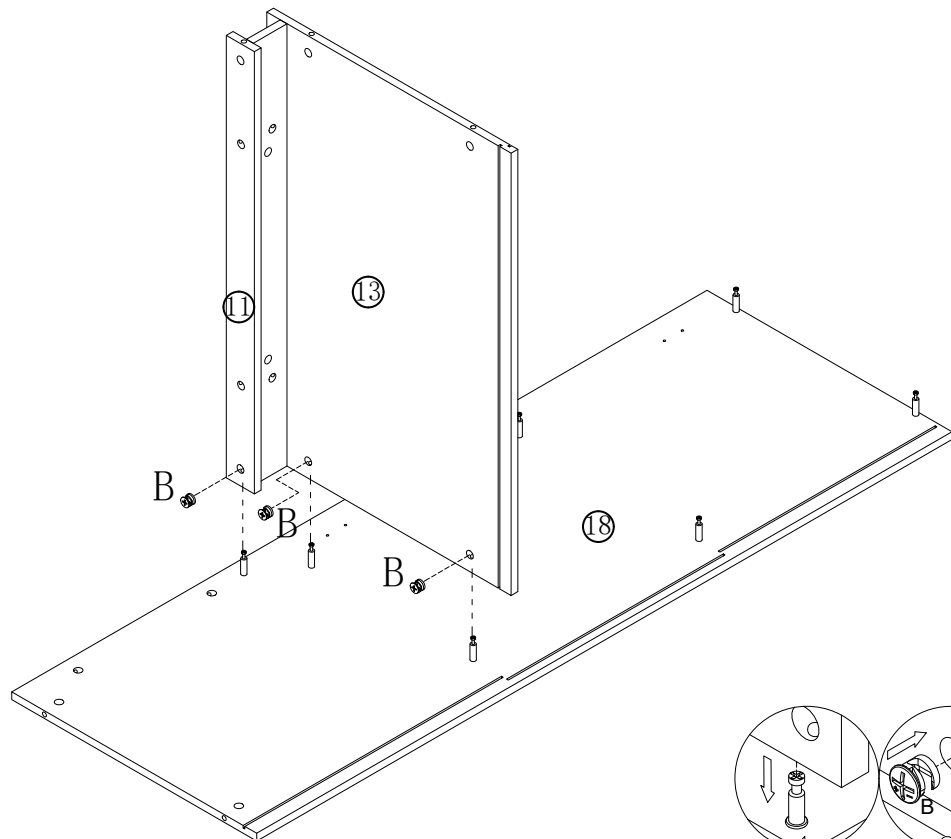
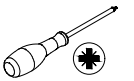

13

B x 4



φ12*9mm

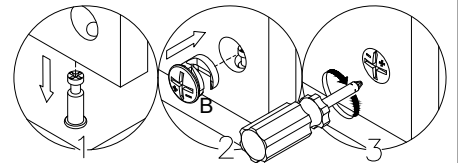
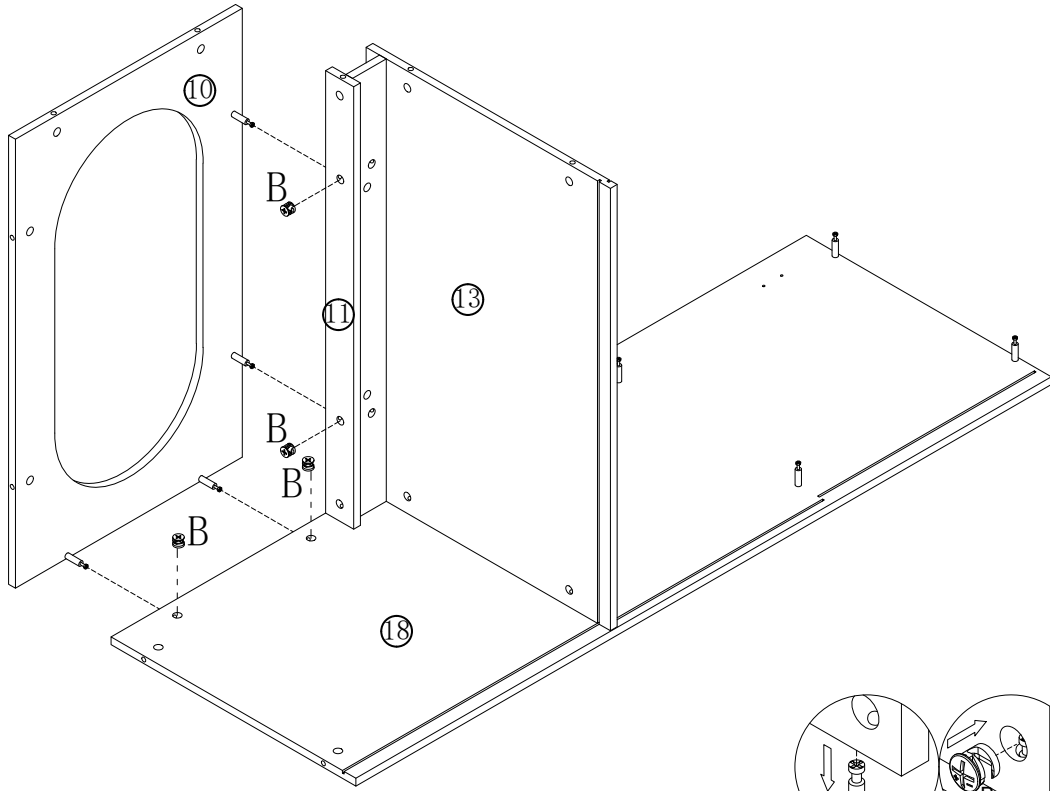
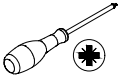

14

B x 4



φ12*9mm

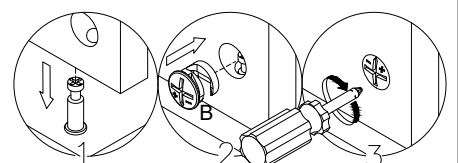
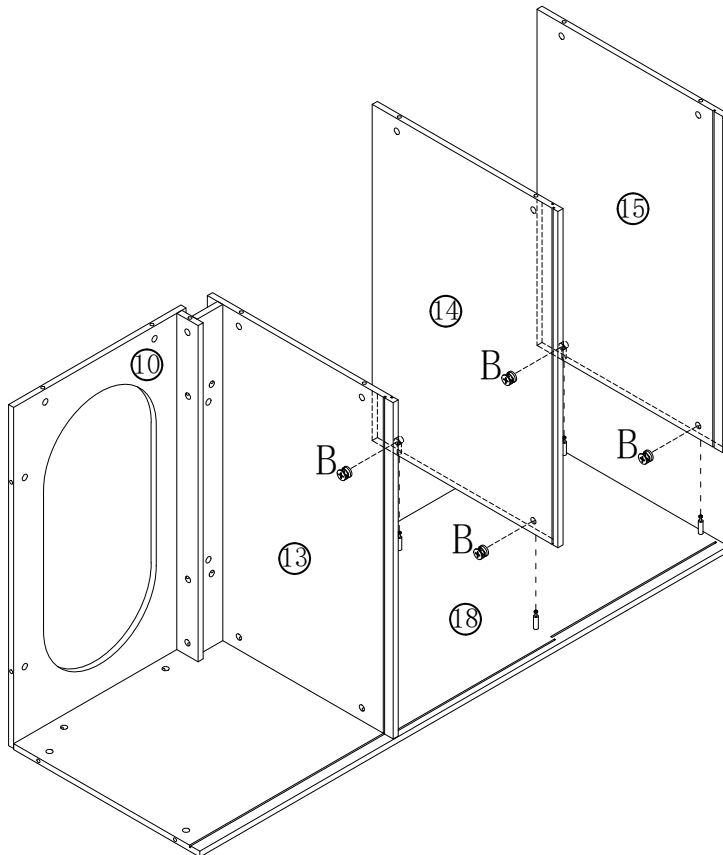
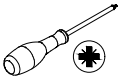

15

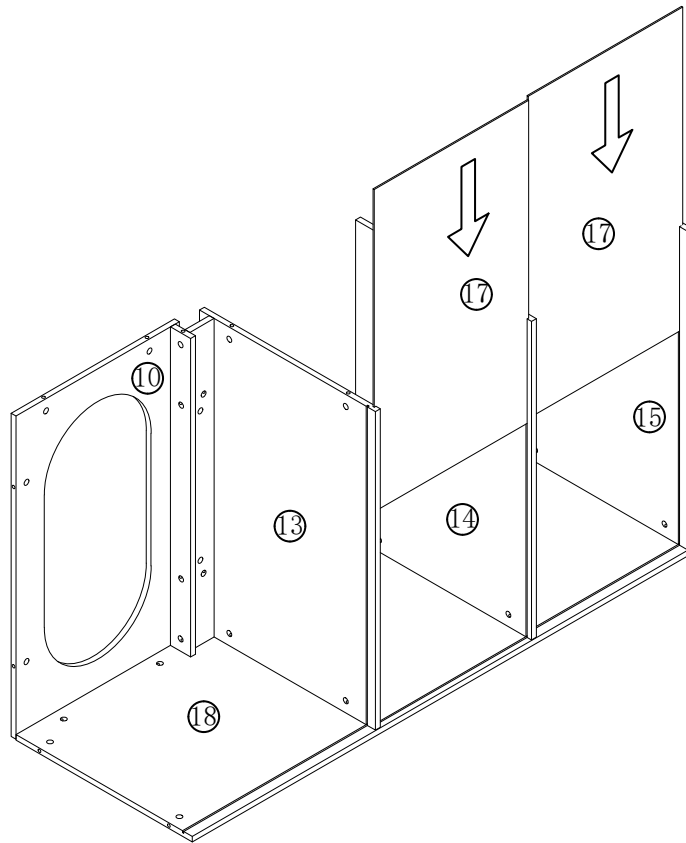

16

B x 9



φ12*9mm

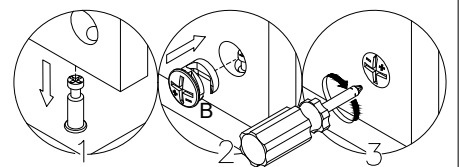
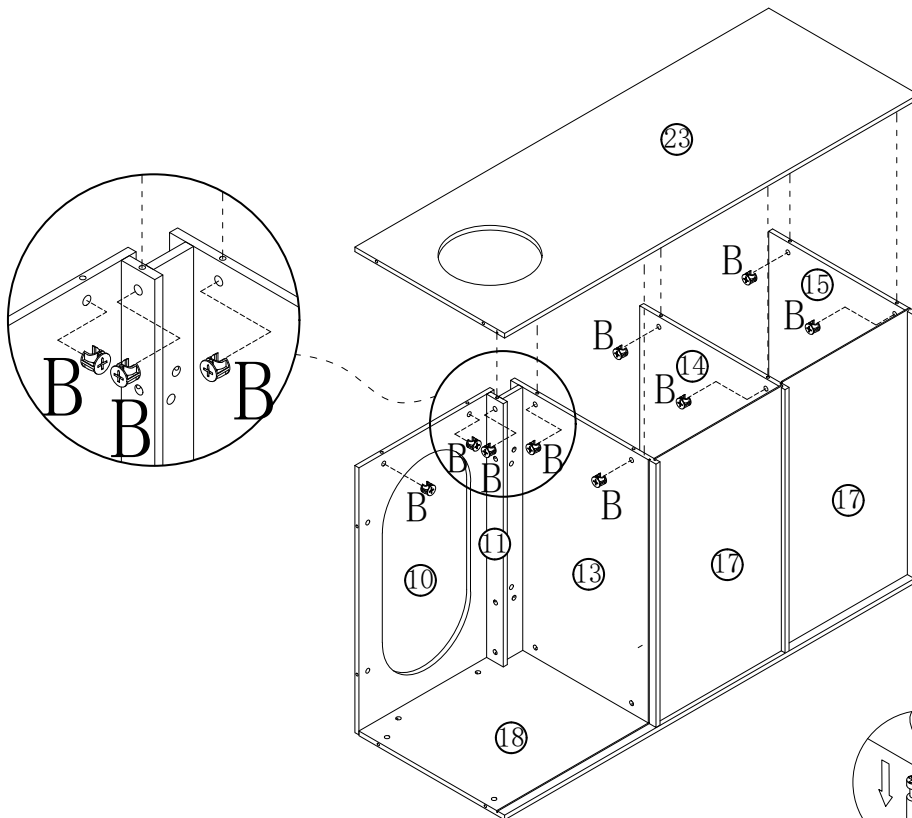
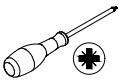

17

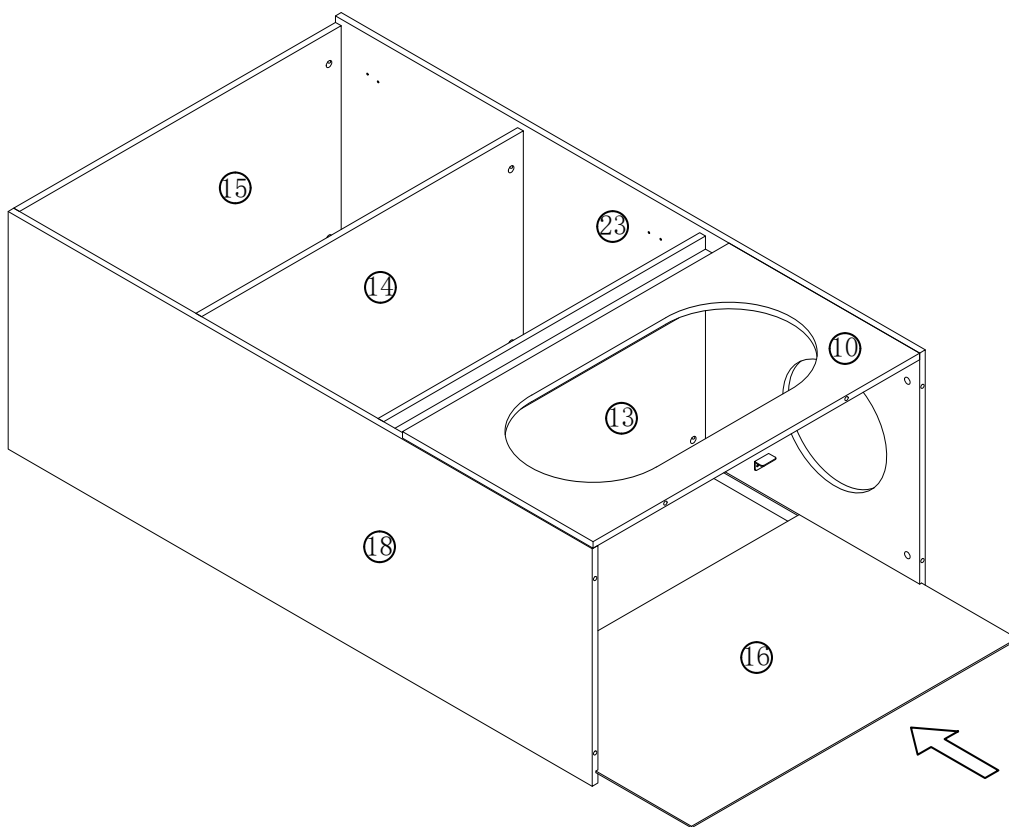

18

B x 6



Ø12*9mm

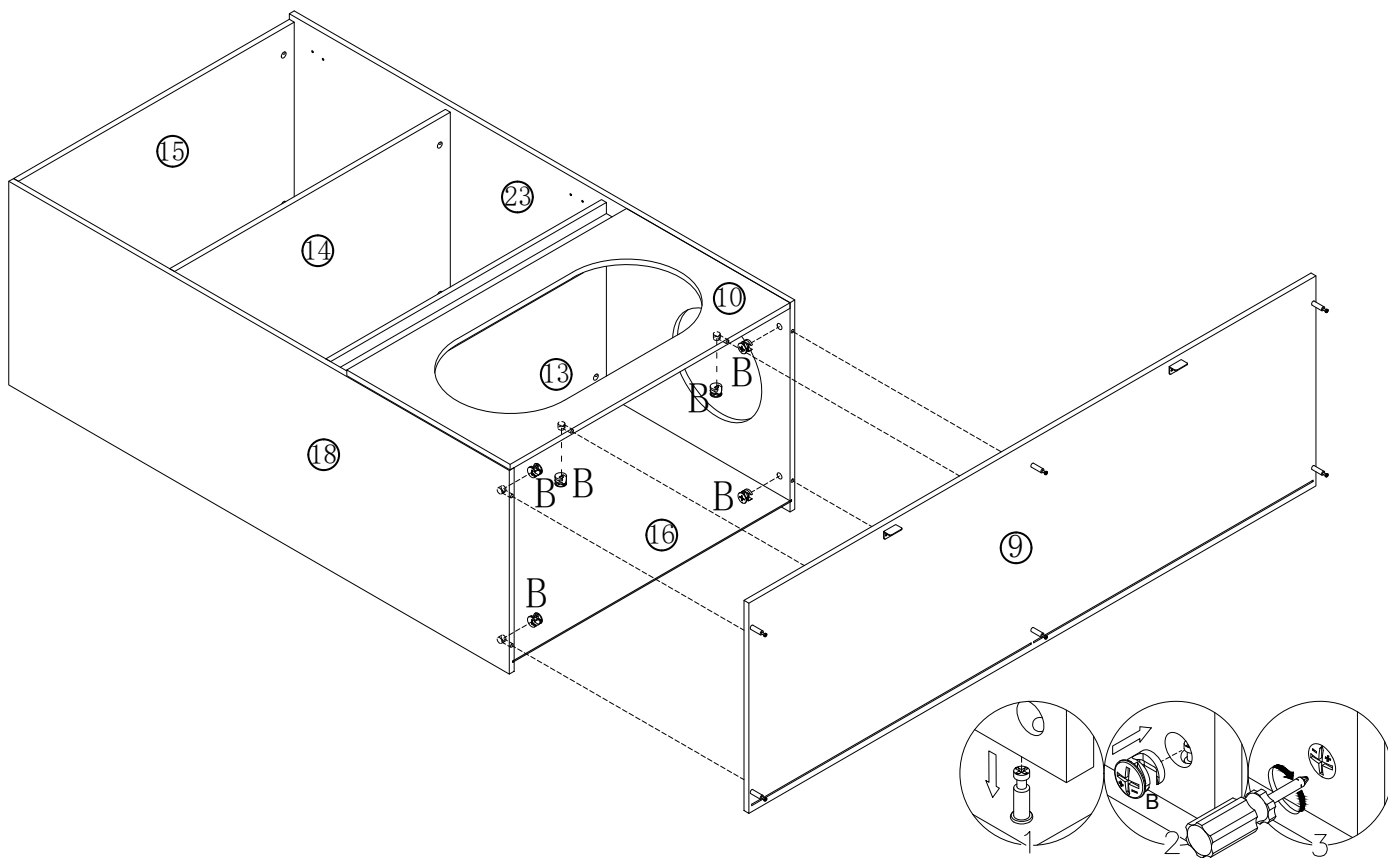
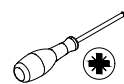

19

B x 6



φ12*9mm

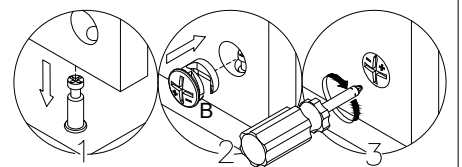
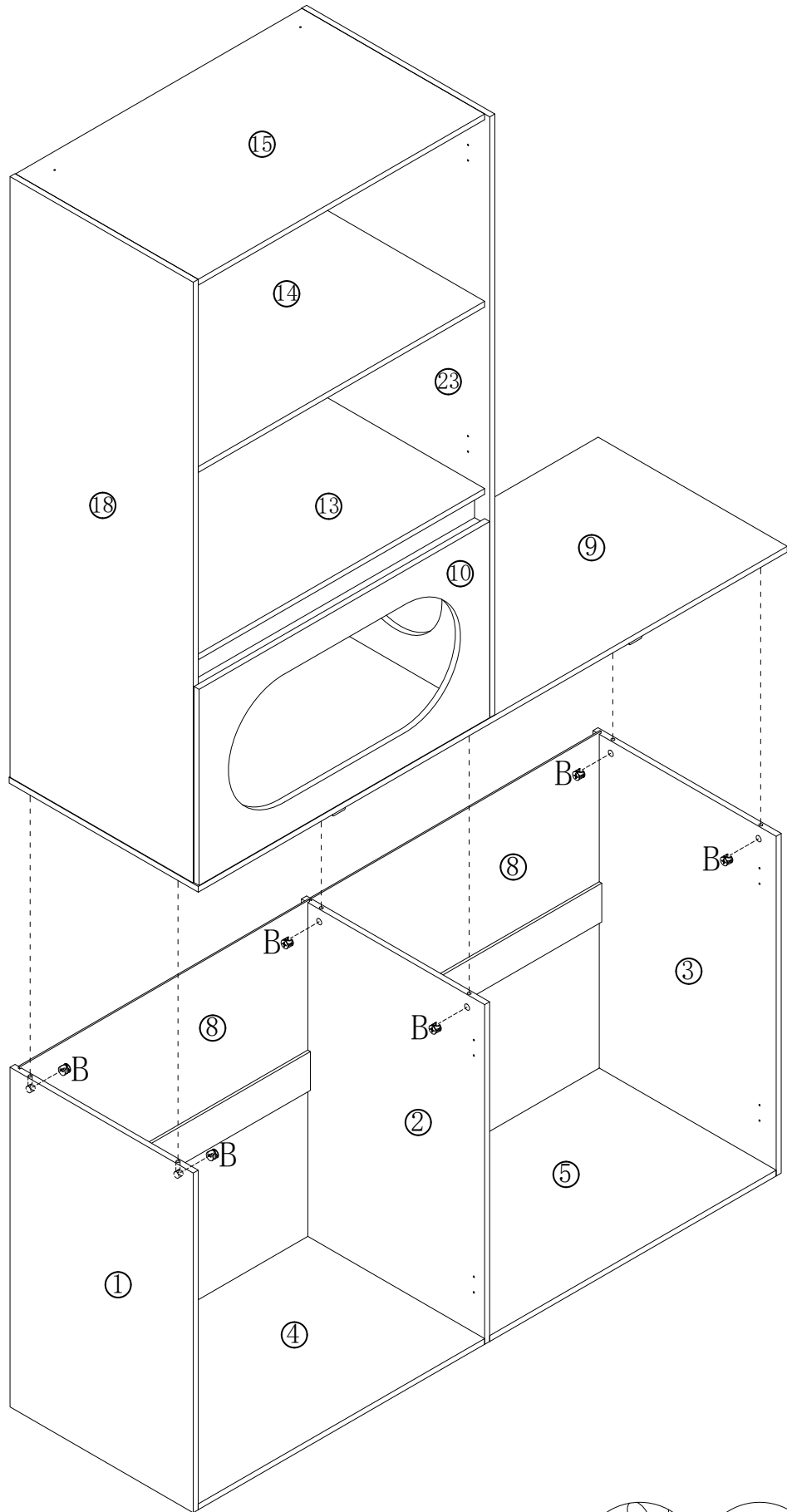
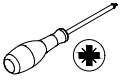

20

I x 42

J x 42



M3.5*14mm

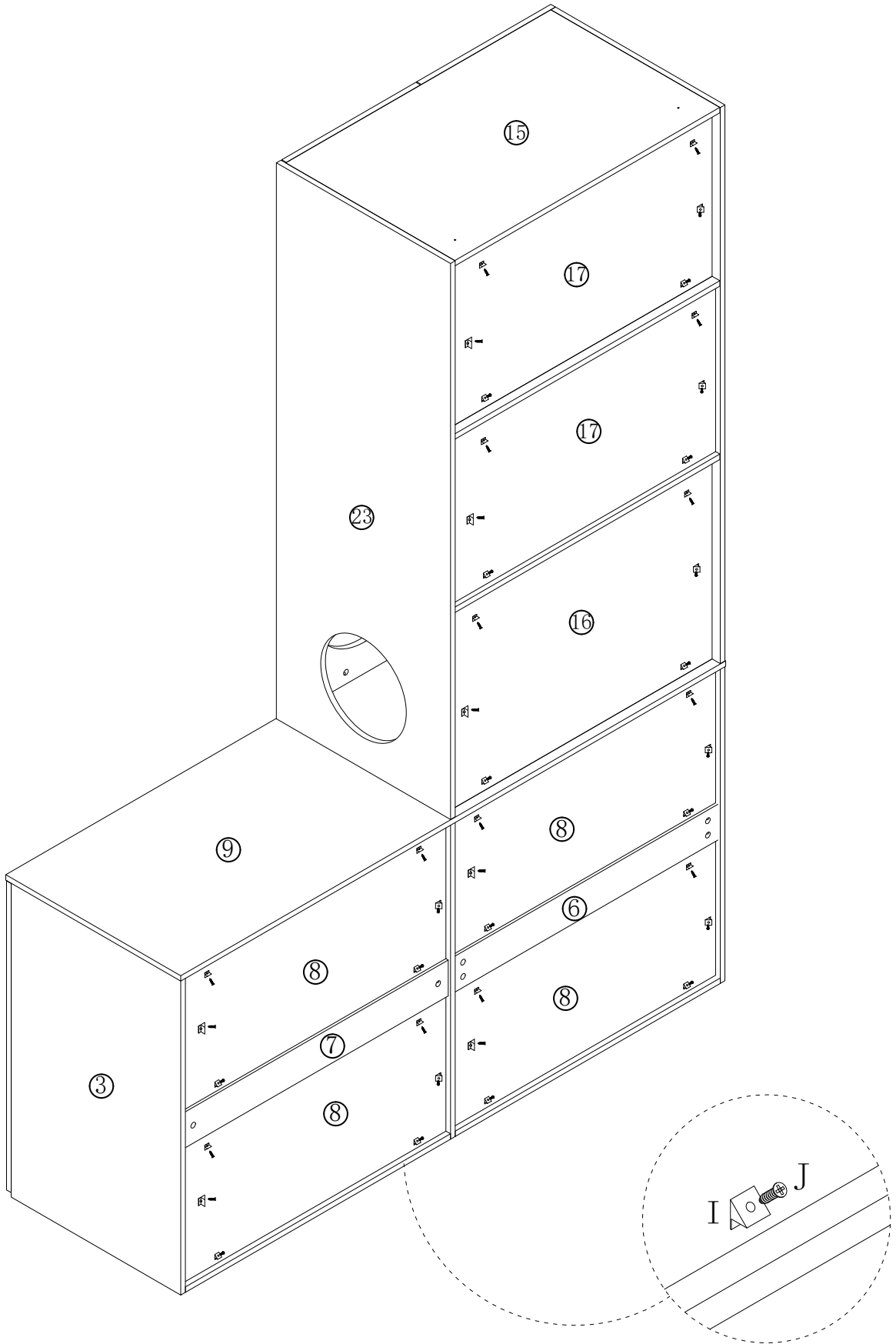
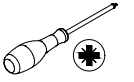

21

C x 24

D x 4

E x 6

H x 2

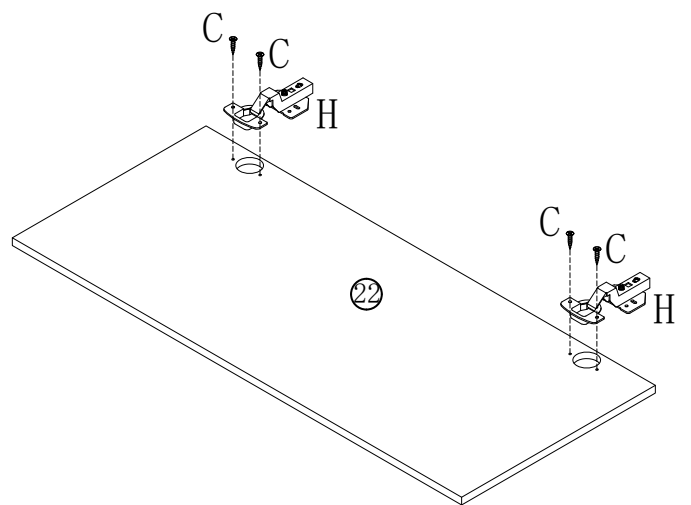
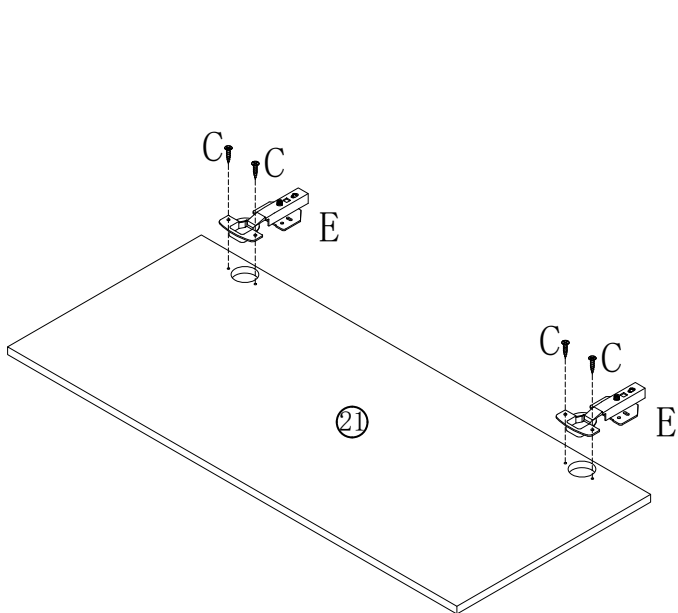
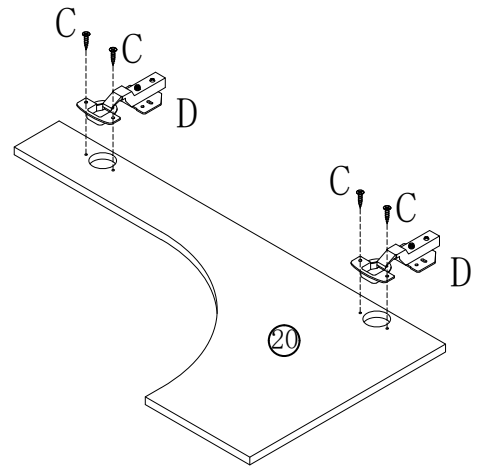
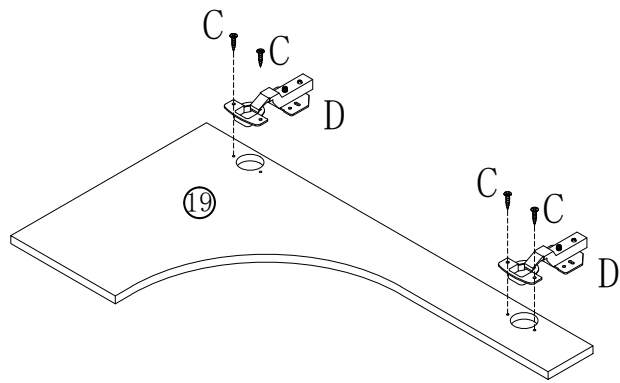
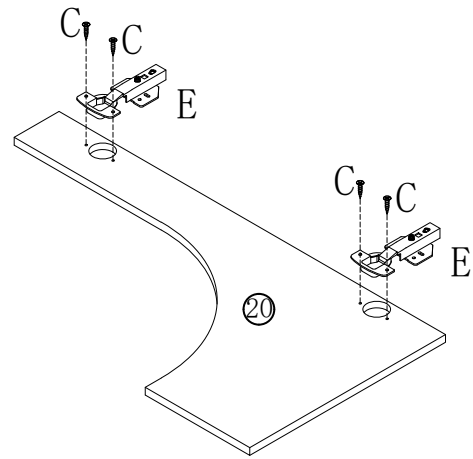
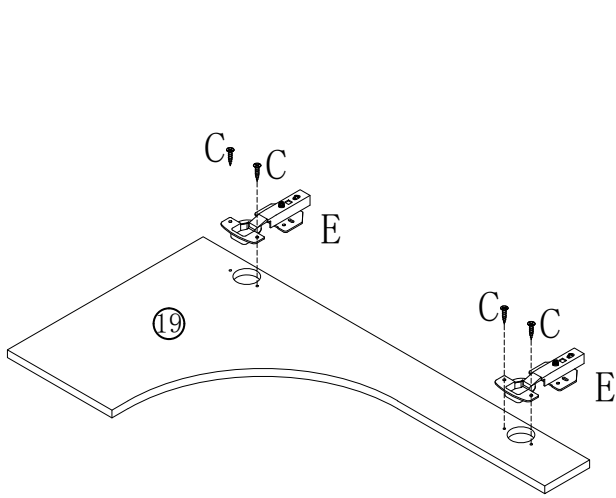
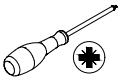
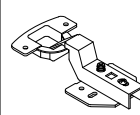
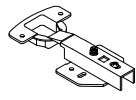
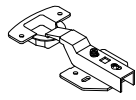
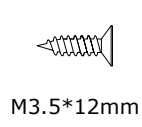

22

C x 16



M3.5*12mm

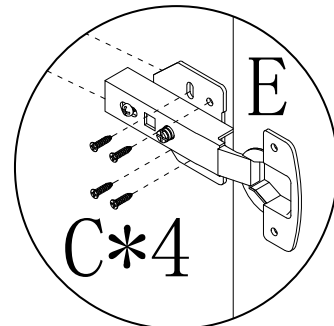
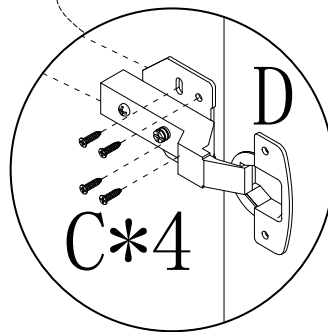
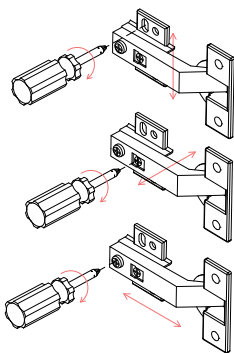
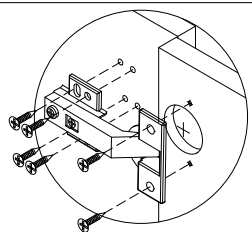
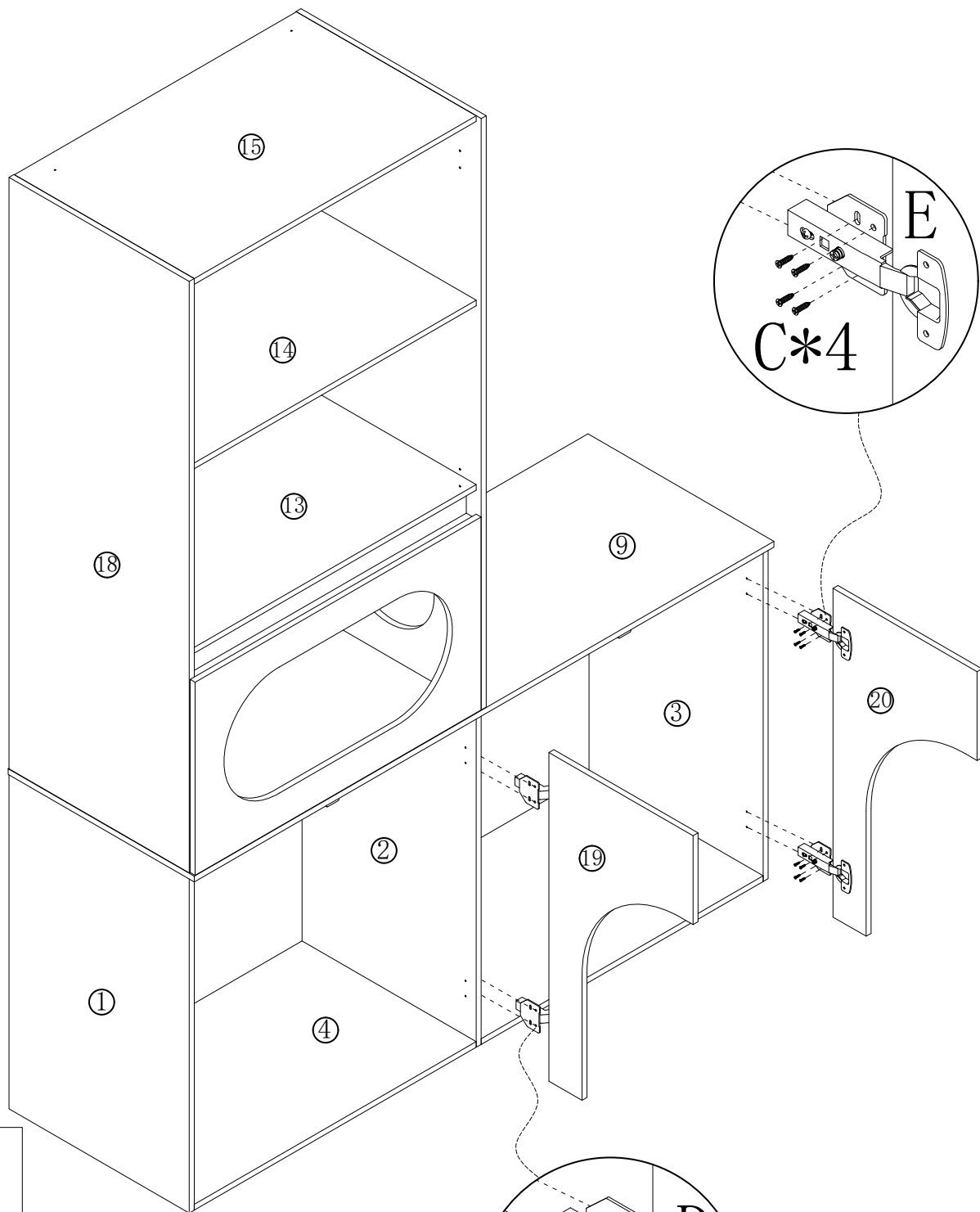

23

C x 16



M3.5*12mm

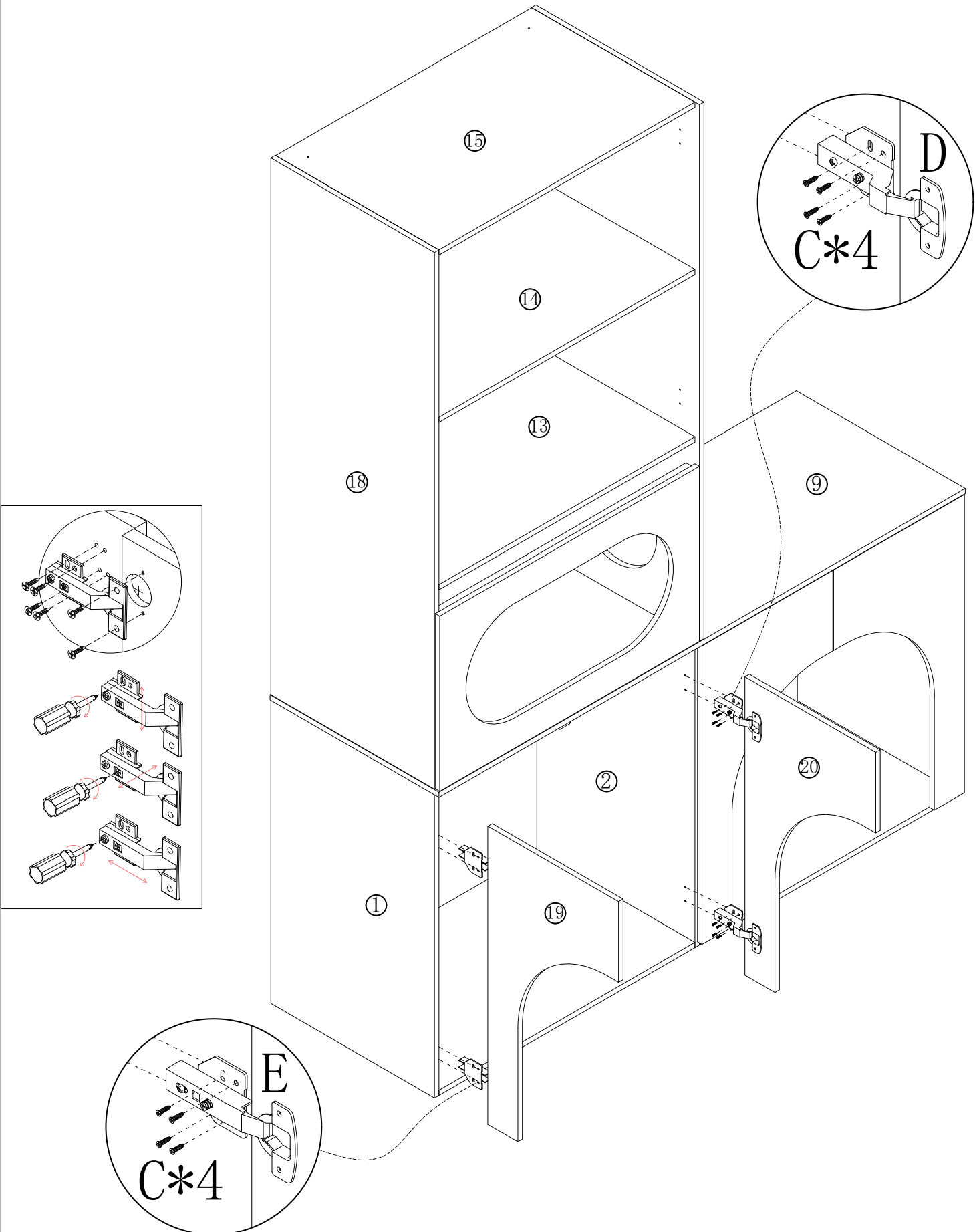
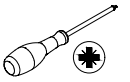

24

C x 16



M3.5*12mm

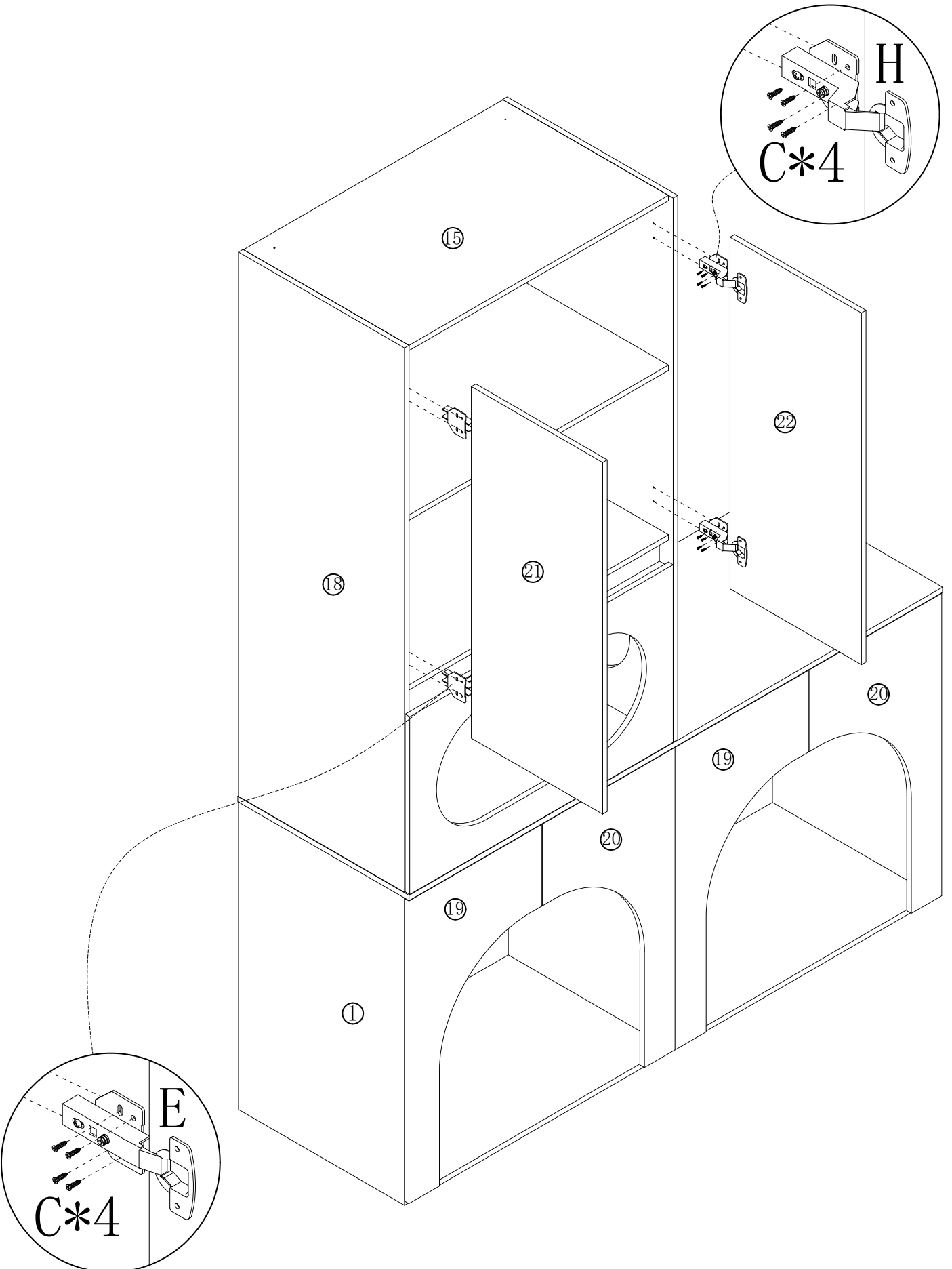
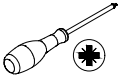

25

M x 2

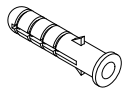

N x 2



L x 2



M4*30mm

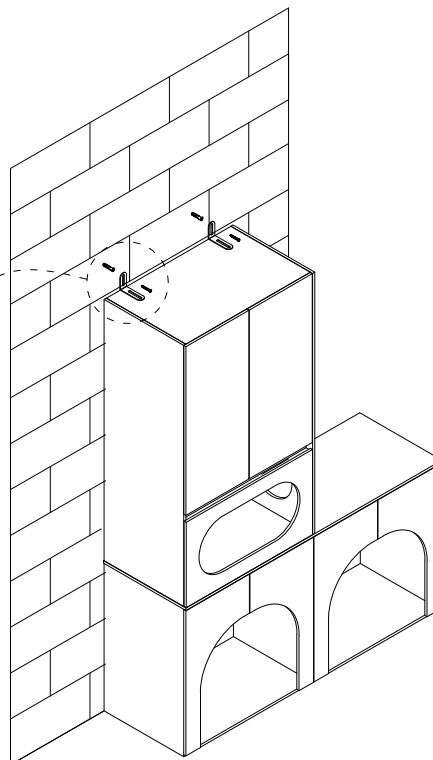
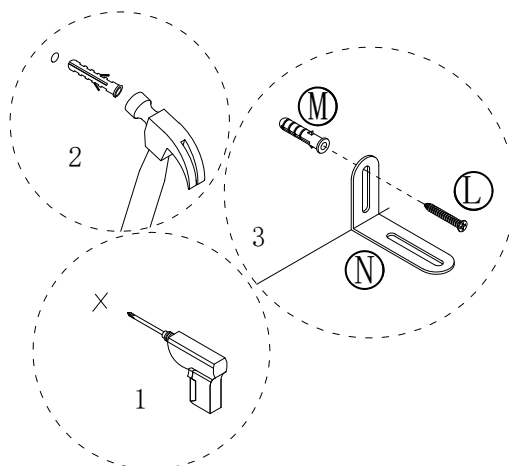

26

J x 2



M3.5*14mm

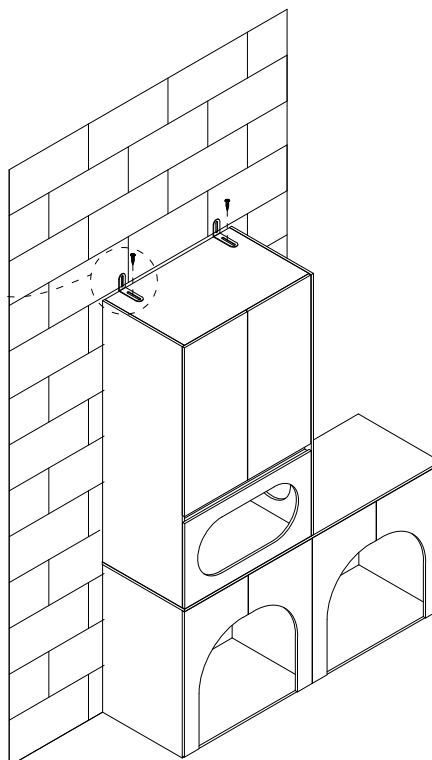
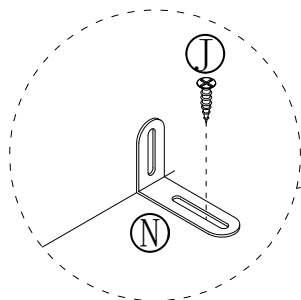
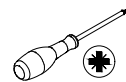

27

F x 50

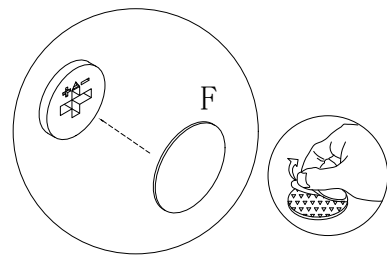
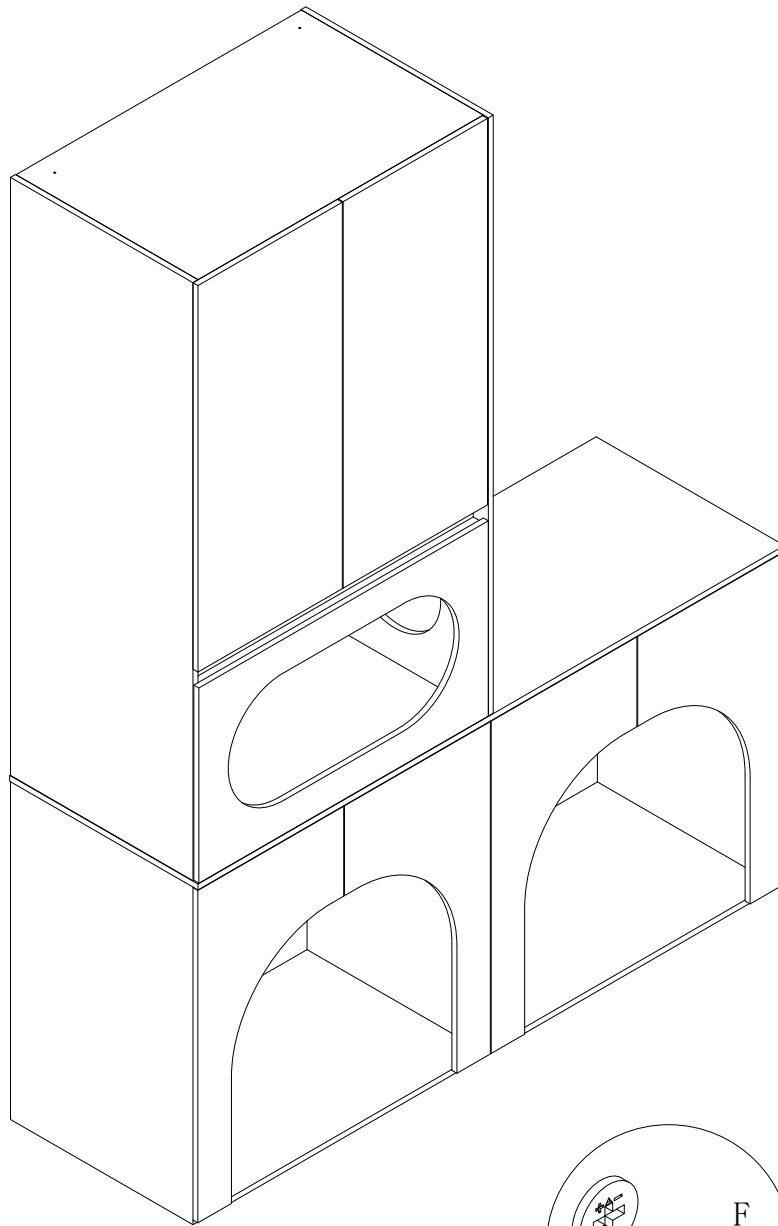

EN:In order to make the product more beautiful,
please paste hardware F on the exposed holes.

DE:Um ein präzises produkt ästhetisieren zu
können, fügen sie hardware F in eine entblöbte
öffnung ein

FR:Afin de rendre le produit plus beau, s' il vous
plaît coller le matériel F sur les trous exposés.

IT:Per rendere il prodotto più bello, incollare l'
hardware F sui fori esposti.

ES:Con el fin de hacer el producto más hermoso, por
favor pega hardware F en los agujeros expuestos

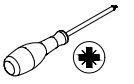

If there is misalignment after you install, adjust the screw to the best condition

