

SKU N635P487096-N635P487097

DE: Installationsanleitung
UK: Installation Instruction
FR: Instruction d'installation
IT: Istruzioni di installazione
ES: Instrucciones de instalación
NL: Installatie-instructies
SE: Installationsanvisningar
PL: Instrukcje instalacji

Unser Produkt wird Ihnen in 2 Paketen geliefert. Die Lieferzeiten dieser 2 Pakete können abweichen, bitte haben Sie etwas Geduld und vielen Dank für Ihr Verständnis.

Our product will be delivered to you in 2 packages. The delivery times of these 2 packages may differ, please be patient and thank you for your understanding.

Notre produit vous sera livré en 2 colis. Les délais de livraison de ces 2 colis peuvent différer, soyez patient et merci pour votre compréhension.

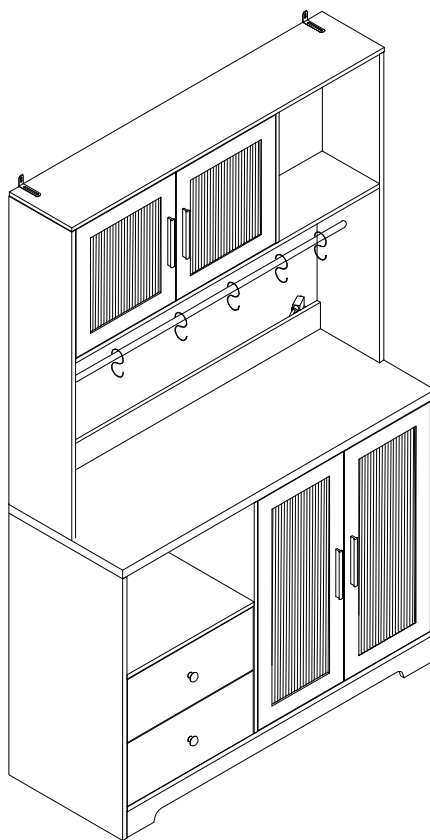
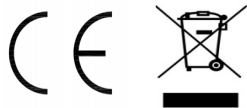

<https://quefairemesdechets.fr>



FR
Cet appareil, ses cordons, et batterie se recyclent
A DÉPOSER EN MAGASIN
OU
A DÉPOSER EN DÉCHÈTERIE

Points de collecte sur www.quefairemesdechets.fr
Privilégiez la réparation ou le don de votre appareil !

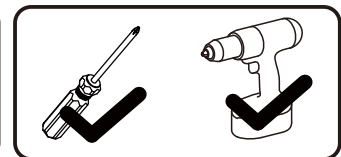

EN_IMPORTANT, RETAIN FOR FUTURE REFERENCE: READ CAREFULLY.

FR_IMPORTANT: A LIRE ATTENTIVEMENT ET À CONSERVER POUR CONSULTATION ULTÉRIURE.

ES_IMPORTANTE, LEA Y GUARDE PARA FUTURAS REFERENCIAS.

DE_, WICHTIG! SORGFÄLTIG LESEN UND FÜR SPÄTER NACHSCHLAGEN AUFBEWAHREN."

IT_IMPORTANTE! CONSERVARE IL PRESENTE MANUALE PER FUTURO RIFERIMENTO E LEGGERLO ATTENTAMENTE.

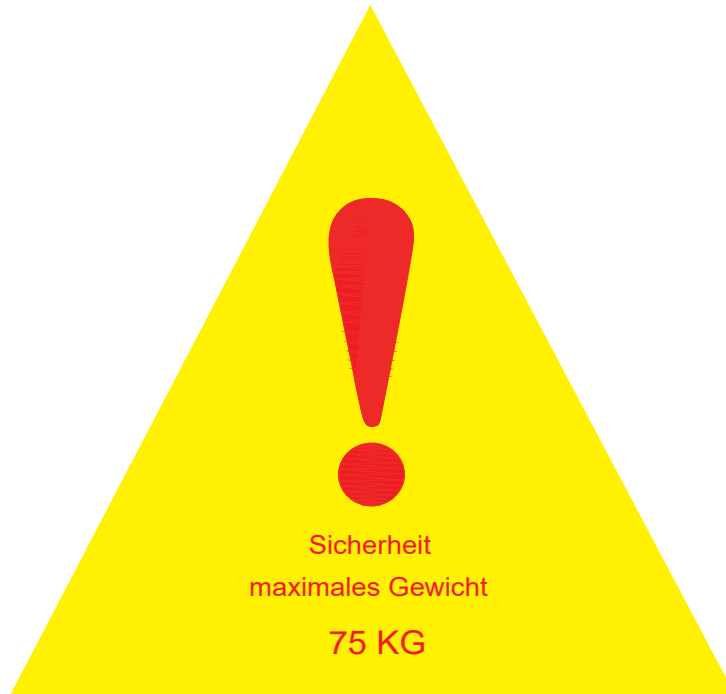

DE

Warnung: Die maximale Belastbarkeit dieses Möbels beträgt:75 kg, bitte nicht überlasten!

EN

Warning: The maximum load-bearing capacity of this furniture is:75 kg, please do not overload!

FR

Avertissement : La capacité de charge maximale de ce meuble est de :75 kg, merci de ne pas surcharger !

IT

Attenzione: la capacità di carico massima di questo mobile è:75 kg, non sovraccaricare!

ES

Advertencia: La capacidad máxima de carga de este mueble es:75 kg, ¡no lo sobrecargue!



[DE]

Warnung: Lesen Sie diese Anleitung vor dem Zusammenbau bitte vollständig durch. Überprüfen Sie, ob Sie alle auf den Seiten aufgeführten Komponenten und Werkzeuge haben. Bewahren Sie die Anleitung zum späteren Nachschlagen auf. Teile des Zusammenbaus lassen sich mit 2 Personen leichter durchführen. Suchen Sie bei Bedarf professionelle Hilfe.

Warnung: Legen Sie alle Teile auf eine ebene Fläche. Legen Sie eine weiche Decke oder Ähnliches darunter, um sie vor Kratzern oder Flecken zu schützen. Vermeiden Sie es, Komponenten über den Boden zu ziehen oder zu schieben.

Warnung: Überprüfen Sie regelmäßig alle Beschläge und Befestigungen, um sicherzustellen, dass sie sicher sind und um Unfälle zu vermeiden. Wenn Teile fehlen, kaputt, beschädigt oder abgenutzt sind, verwenden Sie das Produkt nicht weiter, bis es mit vom Hersteller autorisierten Teilen repariert wurde.

Warnung: Lassen Sie Kinder nicht auf die Möbel klettern, da dies zum Umkippen und zu schweren Verletzungen führen kann. Bauen Sie die Möbel außerhalb der Reichweite von Kindern zusammen.

Warnung: Stellen Sie die Möbel nicht in die Nähe von Feuerquellen oder heißen Gegenständen, um Brandgefahr zu vermeiden.

Warnung: Reinigen Sie die Möbel mit einem feuchten Tuch oder Alkohol. Verwenden Sie keine Reinigungsmittel mit ätzenden Chemikalien.

Warnung: Dieses Produkt ist mit einer Kippschutzvorrichtung ausgestattet. Bitte installieren Sie diese Vorrichtung unbedingt, um unnötige Verletzungen durch Umkippen zu vermeiden.

[EN]

Warning: Please read these instructions fully before starting assembly. Check you have all the components and tools listed on pages. Keep the instructions for later reference. Parts of the assembly will be easier with 2 people. Seek professional assistance if necessary.

Warning: Please place all parts on a flat surface. Place a soft blanket or similar underneath to protect against scratches or stains. Avoid dragging or sliding components across the floor.

Warning: Regularly check all fittings and fastenings to ensure they are secure and to prevent accidents. If any parts are missing, broken, damaged, or worn, discontinue use of the product until repairs have been made using factory authorized parts.

Warning: Do not allow children to climb on the furniture as this may result in tipping and serious personal injury. Assemble the furniture away from the reach of children.

Warning: Do not place furniture close to fire sources or high-temperature objects to avoid the risk of fire. Do not place furniture in damp environments to prevent material damage.

Warning: Clean furniture with a damp cloth or alcohol, avoid using cleaning agents containing corrosive chemicals.

Warning: This product is equipped with an anti-tilt device. Please be sure to install this device to prevent unnecessary injuries caused by tipping.

[FR]

Avertissement : Veuillez lire attentivement ces instructions avant de commencer l'assemblage. Vérifiez que vous disposez de tous les composants et outils répertoriés sur les pages. Conservez les instructions pour référence ultérieure. Certaines parties de l'assemblage seront plus faciles à 2 personnes. Demandez l'aide d'un professionnel si nécessaire.

Avertissement : Veuillez placer toutes les pièces sur une surface plane. Placez une couverture douce ou similaire en dessous pour les protéger des rayures ou des taches. Évitez de faire glisser les composants sur le sol.

Avertissement : Vérifiez régulièrement tous les raccords et fixations pour vous assurer qu'ils sont bien fixés et pour éviter les accidents. Si des pièces manquent, sont cassées, endommagées ou usées, cessez d'utiliser le produit jusqu'à ce que des réparations aient été effectuées à l'aide de pièces autorisées par l'usine.

Avertissement : Ne laissez pas les enfants grimper sur les meubles car cela pourrait entraîner un basculement et des blessures graves. Assemblez les meubles hors de portée des enfants.

Avertissement : Ne placez pas les meubles à proximité de sources de feu ou d'objets à haute température pour éviter tout risque d'incendie.

Avertissement : Nettoyez les meubles avec un chiffon humide ou de l'alcool, évitez d'utiliser des produits de nettoyage contenant des produits chimiques corrosifs.

Avertissement : Ce produit est équipé d'un dispositif anti-basculement. Assurez-vous d'installer ce dispositif pour éviter les blessures inutiles causées par un basculement.



[IT]

Attenzione: leggere attentamente le istruzioni prima di iniziare il montaggio. Verificare di avere tutti i componenti e gli strumenti elencati nelle pagine.

Attenzione: posizionare tutte le parti su una superficie piana. Posizionare una coperta morbida o simile sotto per proteggere da graffi o macchie. Evitare di trascinare o far scivolare i componenti sul pavimento.

Attenzione: controllare regolarmente tutti i raccordi e i dispositivi di fissaggio per assicurarsi che siano sicuri e per prevenire incidenti. Se alcune parti sono mancanti, rotte, danneggiate o usurate, interrompere l'uso del prodotto fino a quando non siano state eseguite le riparazioni utilizzando parti autorizzate dalla fabbrica.

Attenzione: non consentire ai bambini di arrampicarsi sui mobili poiché ciò potrebbe causare ribaltamenti e gravi lesioni personali. Montare i mobili lontano dalla portata dei bambini.

Attenzione: non posizionare i mobili vicino a fonti di fuoco o oggetti ad alta temperatura per evitare il rischio di incendio.

Attenzione: pulire i mobili con un panno umido o alcol, evitare di utilizzare detergenti contenenti sostanze chimiche corrosive.

[ES]

Advertencia: Lea las instrucciones completamente antes de comenzar el montaje. Compruebe que tiene todos los componentes y herramientas que se enumeran en las páginas.

Advertencia: Coloque todas las piezas sobre una superficie plana. Coloque una manta suave o algo similar debajo para protegerlas de rayones o manchas. Evite arrastrar o deslizar los componentes por el piso.

Advertencia: Verifique regularmente todos los accesorios y fijaciones para asegurarse de que estén seguros y evitar accidentes. Si falta alguna pieza, está rota, dañada o desgastada, deje de usar el producto hasta que se hayan realizado las reparaciones con piezas autorizadas de fábrica.

Advertencia: No permita que los niños se suban a los muebles, ya que esto puede provocar que se vuelquen y lesiones personales graves. Monte los muebles fuera del alcance de los niños.

Advertencia: No coloque los muebles cerca de fuentes de fuego u objetos de alta temperatura para evitar el riesgo de incendio.

Advertencia: Limpie los muebles con un paño húmedo o alcohol, evite usar agentes de limpieza que contengan químicos corrosivos.

Importeur	Decobus Handel GmbH		
Adresse	Innungsstraße 9,21244 Buchholz,Deutschland		
URL	https://www.decobusgroup.de		
Hersteller	SHOUGUANG FUSHIWOOD CO.,LTD		
Adresse	EAST CITY INDUSTRIAL ZONE,SHOUGUANG, SHANDONGPROVINCE,CHINA		
Email/URL	200612925@qq.com		
Partienummer	C089FSS20260320TG		
Hergestellt in	China		
<table border="1"><tr><td>EC</td><td>REP</td></tr></table>	EC	REP	Decobus Handel GmbH Innungsstraße 9,21244 Buchholz,Deutschland https://www.decobusgroup.de
EC	REP		

EN

Dear customer,

Thank you for purchasing this product. So that your appliance serves you well, please read all the instructions in this user's manual. If you have any questions, please contact our customer care center.

FR

Cher client,

Nous vous remercions d'avoir acheté ce produit. Afin que vous puissiez profiter pleinement de votre appareil, veuillez lire toutes les instructions de ce manuel d'utilisation. Si vous avez la moindre question, veuillez contacter notre centre d'assistance à la clientèle.

DE

Sehr geehrter Kunde,

Vielen Dank, dass Sie dieses Produkt erworben haben. Damit Ihr Gerät Ihnen gute Dienste leistet, lesen Sie bitte alle Hinweise in diesem Benutzerhandbuch. Wenn Sie Fragen haben, wenden Sie sich bitte an unser Kundendienstzentrum.

ES

Queridos clientes,

Gracias por comprar este producto. Para que su electrodoméstico le sirva mejor, lea todas las instrucciones de este manual del usuario. Si tiene alguna pregunta, comuníquese con nuestro Centro de Atención al Cliente.

IT

Caro Cliente,

Grazie per aver acquistato questo prodotto. Per servirti meglio con questo apparecchio ti prego di leggere tutte le istruzioni in presente manuale utente. In caso di dubbio, si prega di contattare il nostro centro assistenza clienti.

USING CAM LOCK AND QUICKFIT

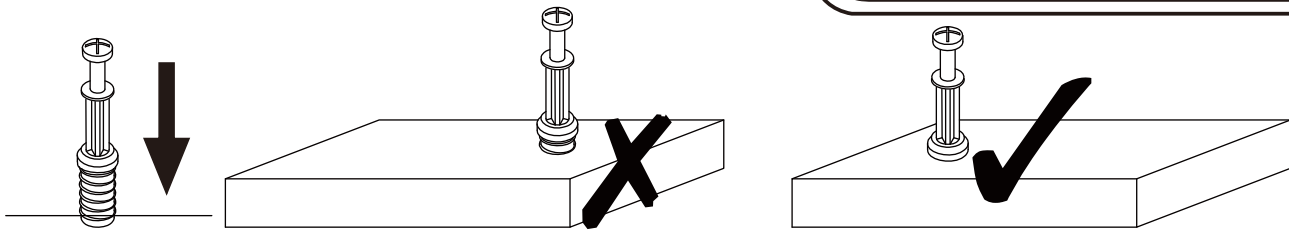

EN_QUICKFIT: Tighten quickfit until shoulder is flush with panel. Do not overtighten or undertighten.

FR_RACCORD RAPIDE: Faites serrer le raccord rapide jusqu'à ce que l'épaulement soit parfaitement encastré dans le panneau. Il ne faut ni trop serrer ni insuffisamment serrer.

ES_QUICKFIT: Apriete quickfit hasta que el hombro se descargue con el panel. NO lo sobreapriete ni lo apriete poco.

DE_QUICKFIT: Ziehen Sie den Quickfit fest, bis die Schulter mit der Platte bündig ist. Bitte nicht zu fest oder zu schwach anziehen.

IT_MONTAGGIO RAPIDO: Stringere il montaggio rapido fino a quando la spalla è a filo con il pannello, non stringere troppo o troppo poco.

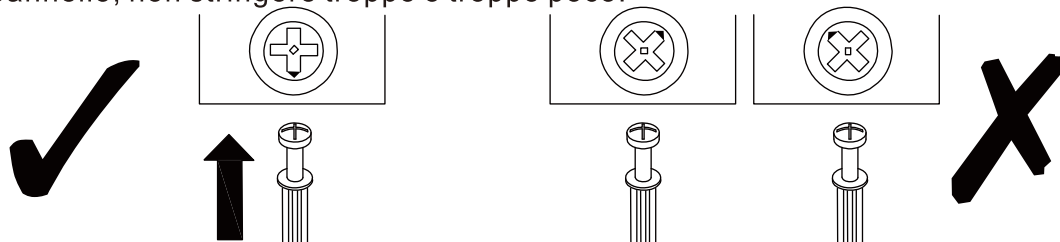

EN_CAM LOCK: When fitting cam lock, ensure starting position is correct before you insert connecting quickfit.

FR_SERRURE BATTEUSE: Avant d'insérer la serrure batteuse, veillez à la bonne orientation avant d'insérer le raccord rapide.

ES_CIERRE DE LA CÁMARA: Cuando instale el cierre de la cámara, asegúrese de que la posición de inicio es correcta antes de que inserte el quickfit conector.

DE_CAM-LOCK: Achten Sie bei der Montage des Cam-Locks auf die richtige Ausgangsposition, bevor Sie den Quickfit einsetzen.

IT_BLOCCAGGIO A CAMMA: Quando si monta il bloccaggio a camma, assicurarsi che la posizione iniziale sia corretta prima di inserire il montaggio rapido di collegamento.

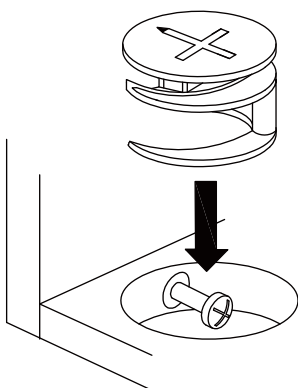

EN_Quickfit head should be in the centre of the cam lock when the two panels are joined.

Cam lock should be inserted before quickfit.

FR_Lorsque les deux panneaux sont assemblés, la tête du raccord rapide doit reposer au centre de la serrure batteuse. Il faut insérer la serrure batteuse avant le raccord rapide.

ES_El cabezal del quickfit debe estar en el centro del cierre de la cámara cuando se unan los dos paneles.

Se debe insertar el cierre de la cámara antes que el quickfit.

DE_Der Quickfit-Kopf sollte sich in der Mitte des Cam-Locks befinden, wenn die beiden Platten zusammengefügt sind.

Der Cam-Lock sollte vor dem Quickfit eingesetzt werden.

IT_La testa del montaggio rapido deve trovarsi al centro del bloccaggio a camma quando i due pannelli sono uniti.

Il Bloccaggio a Camma deve essere inserito prima del montaggio rapido.

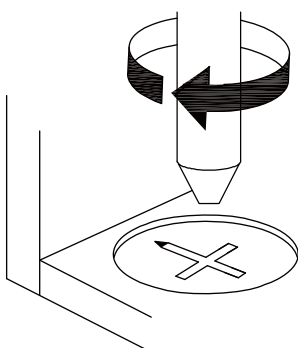

EN_Turn cam lock clockwise to tighten.

FR_Faites tourner la serrure batteuse dans le sens des aiguilles d'une montre pour la resserrer.

ES_Gire el cierre de la cámara en sentido horario para apretarlo.

DE_Drehen Sie den Cam-Lock im Uhrzeigersinn, um ihn festzuziehen.

IT_Ruotare il bloccaggio a camma in senso orario per stringere.

EN It may be necessary to adjust the hinges so that the doors align. Use the instructions below as a guide.

FR Il est parfois nécessaire d'ajuster les charnières pour un meilleur alignement des portes. Servez-vous des instructions ci-dessous comme guide.

ES Puede que sea necesario ajustar los quicios de forma que se alineen las puertas. Use las instrucciones que aparecen debajo como guía.

DE Möglicherweise müssen Sie die Scharniere so einstellen, dass die Türen ausgerichtet sind. Verwenden Sie die nachstehenden Anweisungen als Leitfaden.

IT Potrebbe essere necessario regolare le cerniere in modo che le porte siano allineate. Per fare ciò attenersi alle istruzioni sottostanti.

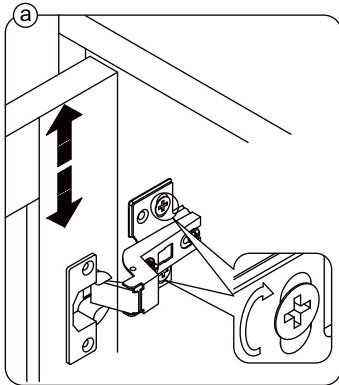

EN To adjust the door vertically loosen the screw as shown and move up and down as needed.

FR Si vous souhaitez régler la porte **verticalement**, desserrez la vis comme indiqué et déplacez la porte de haut en bas selon les besoins.

ES Para ajustar la puerta **verticalmente** afloje el tornillo tal y como se muestra y muévalo hacia arriba o hacia abajo según sea necesario.

DE Um die Tür **vertikal** auszurichten, lösen Sie die Schraube wie abgebildet und bewegen Sie sie nach Bedarf nach oben oder nach unten.

IT Per allineare la porta **verticalmente** allentare la vite come mostrato e spostarla in alto o in basso secondo necessità.

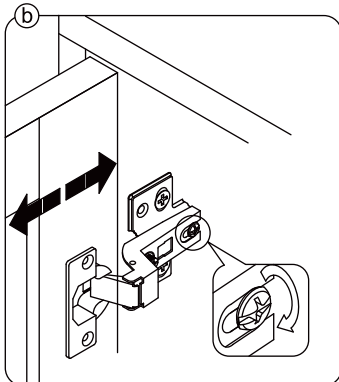

EN To adjust the gap from the door to the main frame turn the screw clockwise or anti-clockwise as needed.

FR Si vous souhaitez ajuster l'**écart** entre la porte et le cadre principal, tournez la vis dans le sens des aiguilles d'une montre ou dans le sens inverse, si nécessaire.

ES Para ajustar el **espacio** desde la puerta al marco principal, gire el tornillo en sentido horario o antihorario, según se necesite.

DE Um den **Abstand** von der Tür zum Hauptrahmen auszurichten, drehen Sie die Schraube je nach Bedarf im oder gegen den Uhrzeigersinn.

IT Per regolare lo **spazio** tra la porta e il telaio principale, avvitare o svitare la vite secondo necessità.

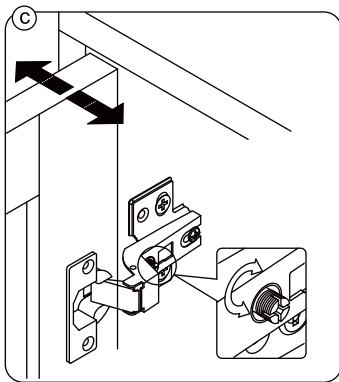

EN To adjust the door laterally adjust the screw as shown by turning clockwise or anti-clockwise.

FR Si vous souhaitez ajuster la porte **latéralement**, ajustez la vis comme indiqué en tournant dans le sens des aiguilles d'une montre ou dans le sens inverse des aiguilles d'une montre.

ES Para ajustar la puerta **lateralmente** ajuste el tornillo tal y como se muestra girándolo en sentido horario y antihorario.

DE Um die Tür **seitlich** auszurichten, stellen Sie bitte die Schraube wie abgebildet durch Drehen im oder gegen den Uhrzeigersinn ein.

IT Per allineare la porta **lateralmente** regolare la vite come mostrato, avvitandola o svitandola.

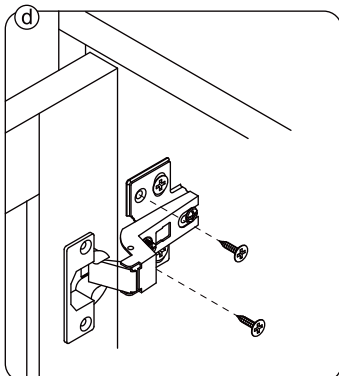

EN Please fix other screws

FR Merci de serrer les autres vis.

ES Fije los demás tornillos

DE Befestigen Sie bitte die anderen Schrauben











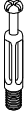
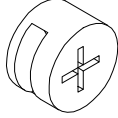
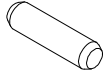
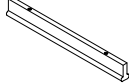
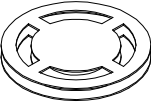
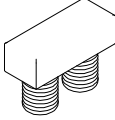

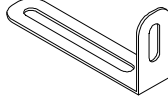
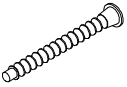
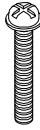
IT Fissare le altre viti

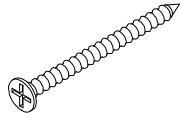
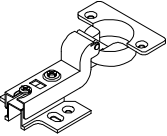
DE: Vor dem Einbau die Schrauben in die Löcher stecken und festziehen, aber nicht bis 100%, 70% bis 80% anziehen reicht aus. Schließlich, nachdem alle Schrauben installiert sind, ziehen Sie alle Schrauben auf 100%. Wenn Sie auf diese Probleme stoßen, wie z. B. Fehlausrichtung der Löcher oder Unfähigkeit, bestimmte Teile zu installieren, überprüfen Sie bitte, ob die Schrauben korrekt verwendet werden und passen Sie die Dichtigkeit der Schrauben an.

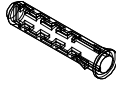
UK: Before installation, insert the screws into the holes and tighten them, but do not tighten them to 100%, 70% to 80% is sufficient. Finally, after all screws are installed, tighten all screws to 100%. If you encounter these issues, such as if the holes cannot be aligned or some parts cannot be installed, please check if the screws are used correctly and adjust the tightness of the screws.

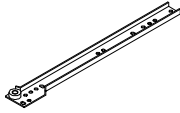
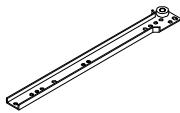
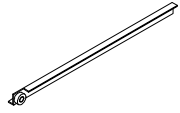
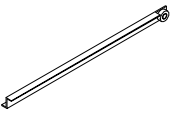
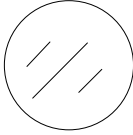
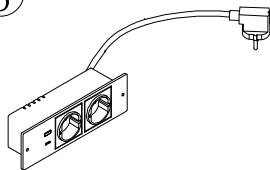
FR: Insérer la vis dans le trou avant la fin de l'assemblage, serrer la vis, mais ne pas serrer à 100%, 70% ~ 80% est correct. Enfin, une fois que toutes les vis sont bien serrées, toutes les vis sont serrées à 100%. Si vous rencontrez ces problèmes, par exemple si les trous ne sont pas alignés ou si certaines pièces ne peuvent pas être montées, vérifiez que les vis sont utilisées correctement et Ajustez leur serrage.

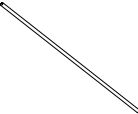
BOX-1/2 SKU:N635P487097

<p>(A)</p>  <p>Cam Bolt x 54</p>	<p>(B)</p>  <p>Cam Lock 12 Plate thick x 54</p>	<p>(C)</p>  <p>Wooden tenon x 31</p>	<p>(D)</p>  <p>turntable x 4</p>
<p>(E)</p>  <p>LED strip x1</p>	<p>(F)</p>  <p>door stop x 2</p>	<p>(G)</p>  <p>3.5*14 self-tapping x 70</p>	<p>(H)</p>  <p>Anti toppling angle iron x 2</p>
<p>(I)</p>  <p>5*40 Wood tooth screw x 12</p>	<p>(J)</p>  <p>hand screw x 10</p>	<p>(K)</p>  <p>Backboard clamp x30</p>	<p>(L)</p>  <p>3.5*35 self-tapping x 8</p>
<p>(M)</p>  <p>Hinge x 8</p>	<p>(N)</p>  <p>3*14 self-tapping x30</p>	<p>(O)</p>  <p>6*30 expansion bolt x 2</p>	<p>(P)</p>  <p>4*30 self-tapping x 8</p>
<p>(Q)</p>  <p>Partition bracket x8</p>	<p>CL</p>  <p>Runner300mm x 2</p>	<p>CR</p>  <p>Runner300mm x 2</p>	<p>DL</p>  <p>Runner300mm x 2</p>
<p>DR</p>  <p>Runner300mm x 2</p>	<p>(R)</p>  <p>Perfect sticker x54</p>	<p>(S)</p>  <p>power strip x1</p>	<p>(T)</p>  <p>power strip x5</p>
<p>(U)</p>  <p>iron pipe x 1</p>	<p>(V)</p>  <p>angle iron x 1</p>	<p>(W)</p>  <p>turntable x 2</p>	

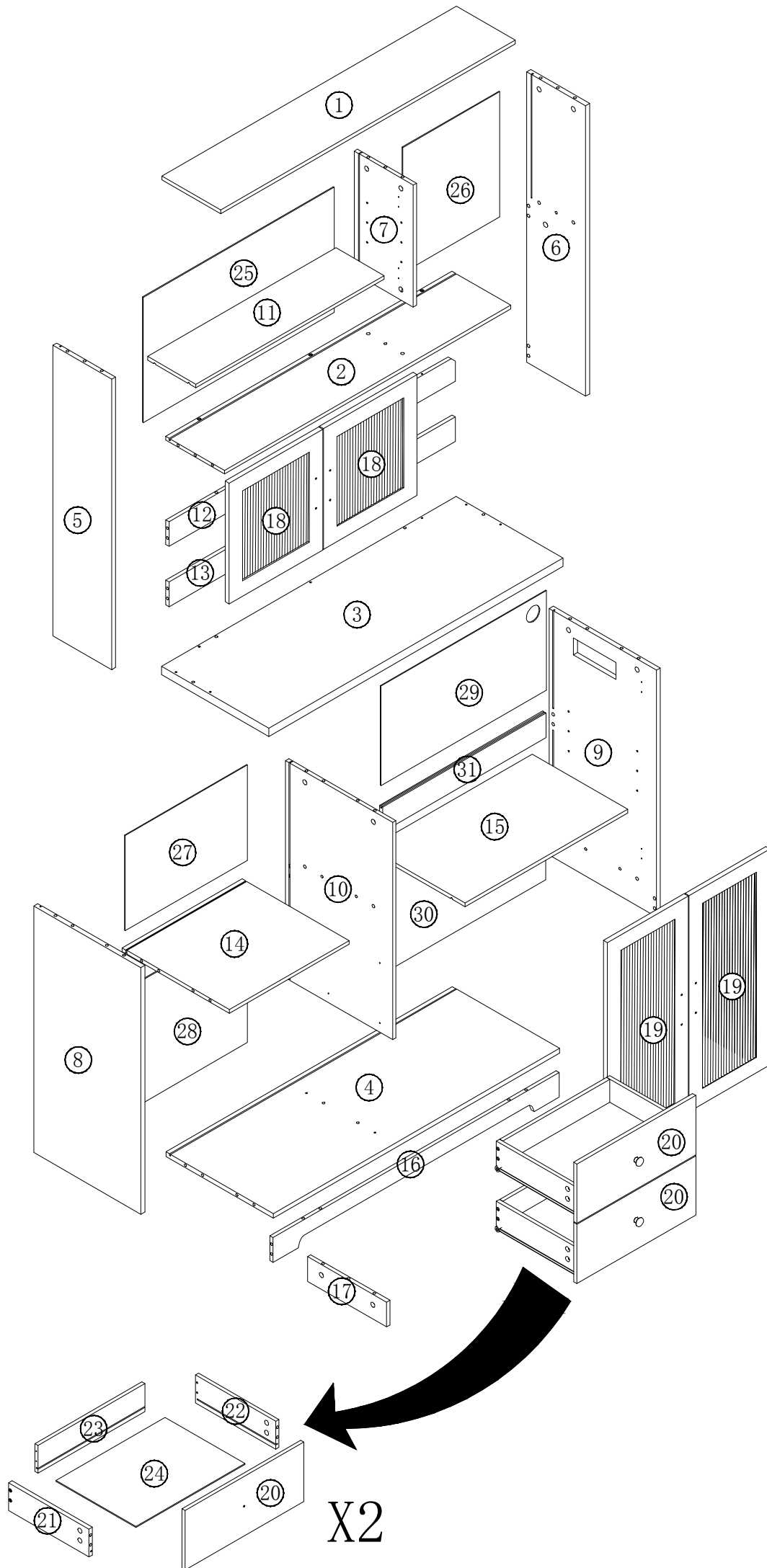

N635P487096

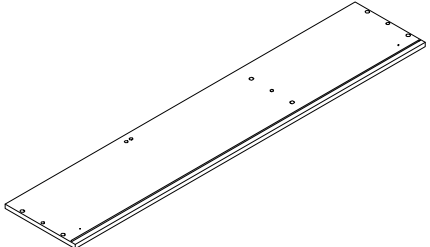
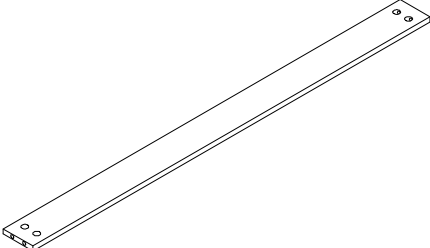
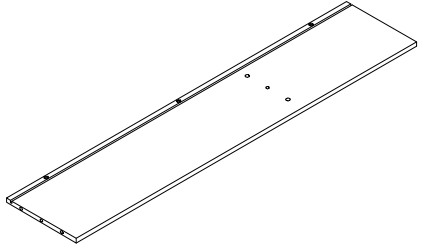
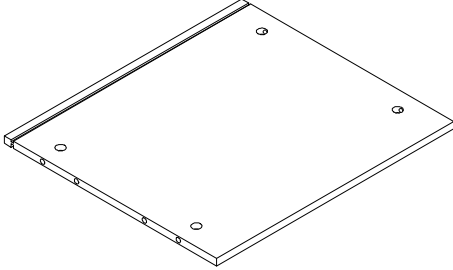
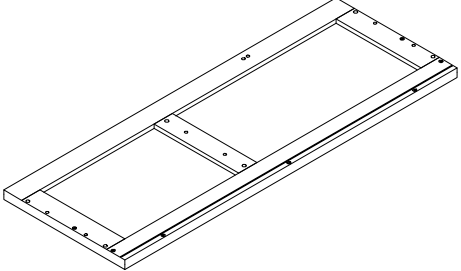
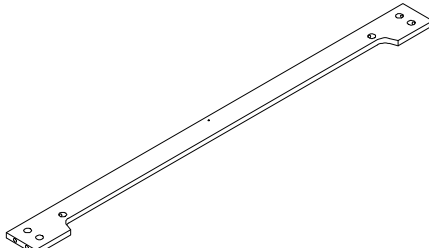
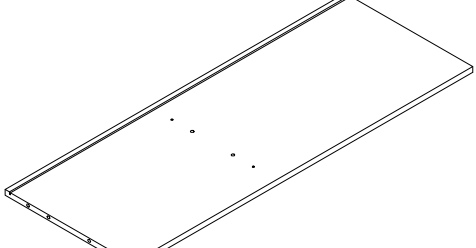
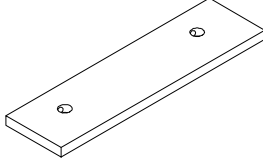
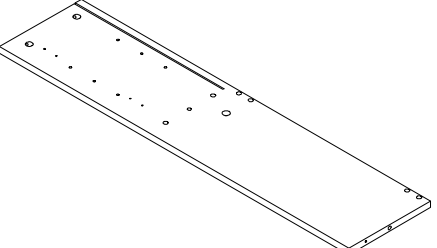
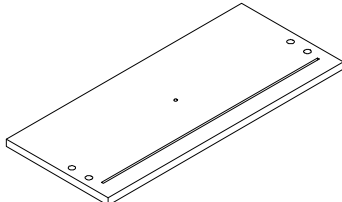
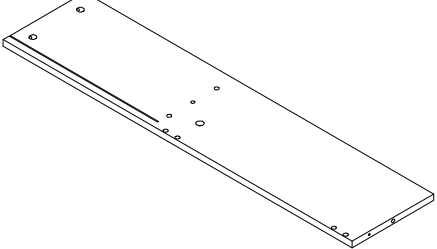
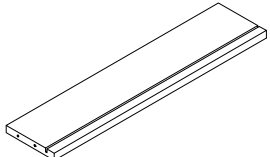
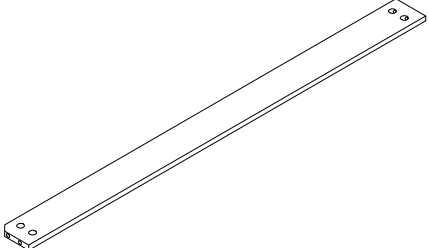
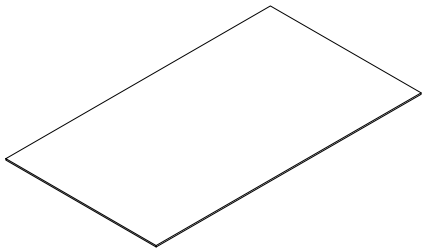
<p>①</p>  <p>1</p>	<p>⑬</p>  <p>1</p>
<p>②</p>  <p>1</p>	<p>⑭</p>  <p>1</p>
<p>③</p>  <p>1</p>	<p>⑯</p>  <p>1</p>
<p>④</p>  <p>1</p>	<p>⑰</p>  <p>1</p>
<p>⑤</p>  <p>1</p>	<p>⑳</p>  <p>2</p>
<p>⑥</p>  <p>1</p>	<p>㉓</p>  <p>2</p>
<p>⑫</p>  <p>1</p>	<p>㉕</p>  <p>1</p>

②6

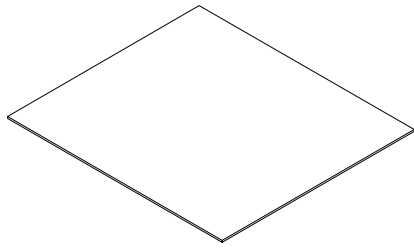

1

N635P487097

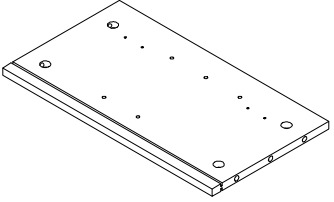
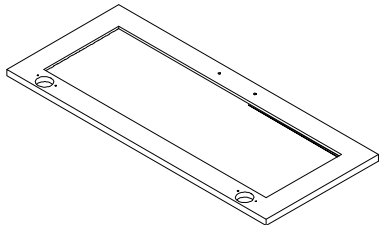
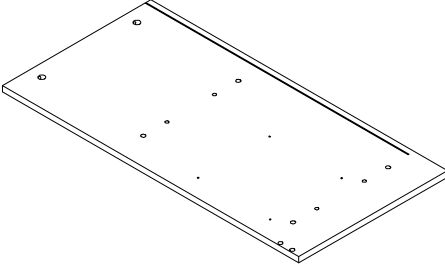
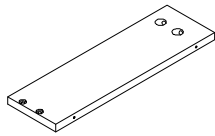
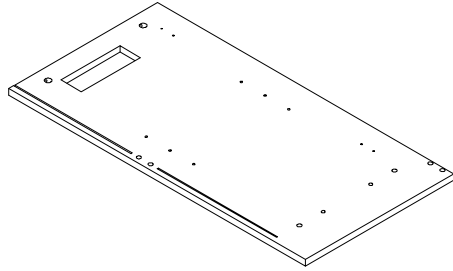
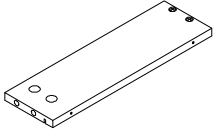
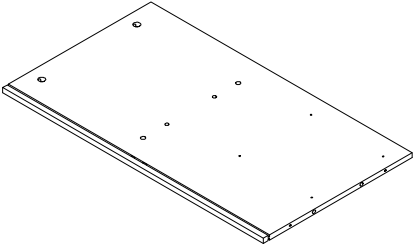
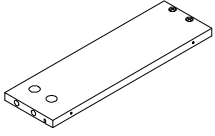
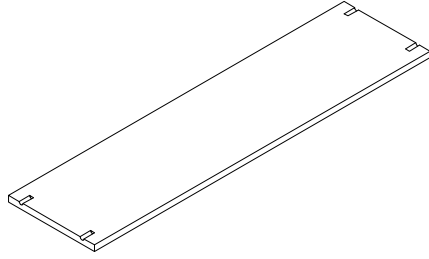
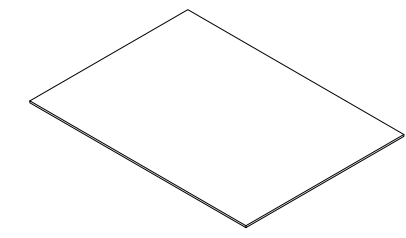
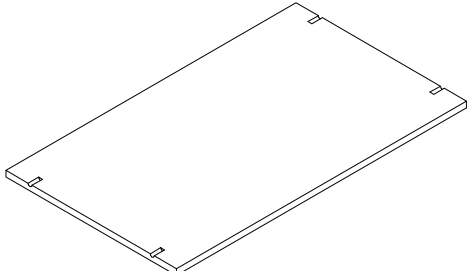
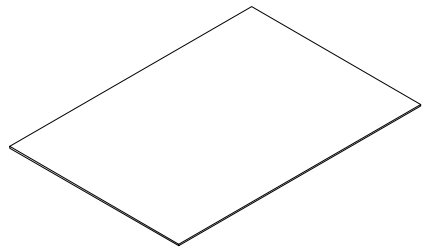
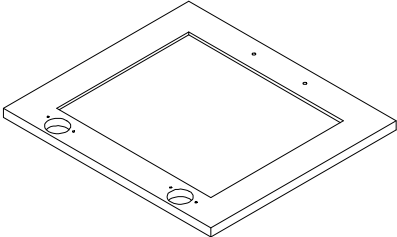
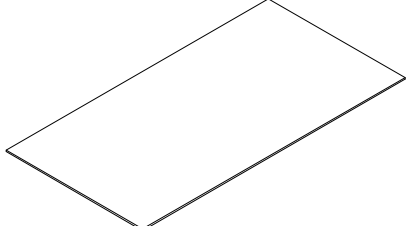

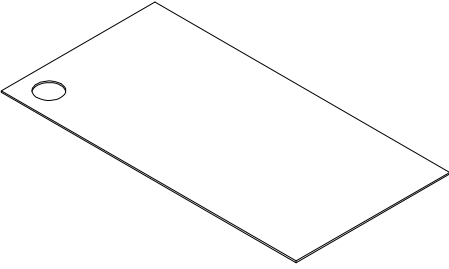
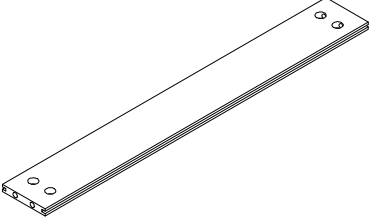
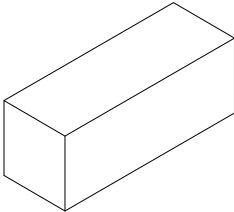

<p>⑦</p>  <p>1</p>	<p>⑱</p>  <p>2</p>
<p>⑧</p>  <p>1</p>	<p>⑳</p>  <p>2</p>
<p>⑨</p>  <p>1</p>	<p>㉑</p>  <p>2</p>
<p>⑩</p>  <p>1</p>	<p>㉒</p>  <p>2</p>
<p>⑪</p>  <p>1</p>	<p>㉓</p>  <p>1</p>
<p>⑮</p>  <p>1</p>	<p>㉔</p>  <p>1</p>
<p>⑱</p>  <p>2</p>	<p>⑳</p>  <p>1</p>

N635P487097

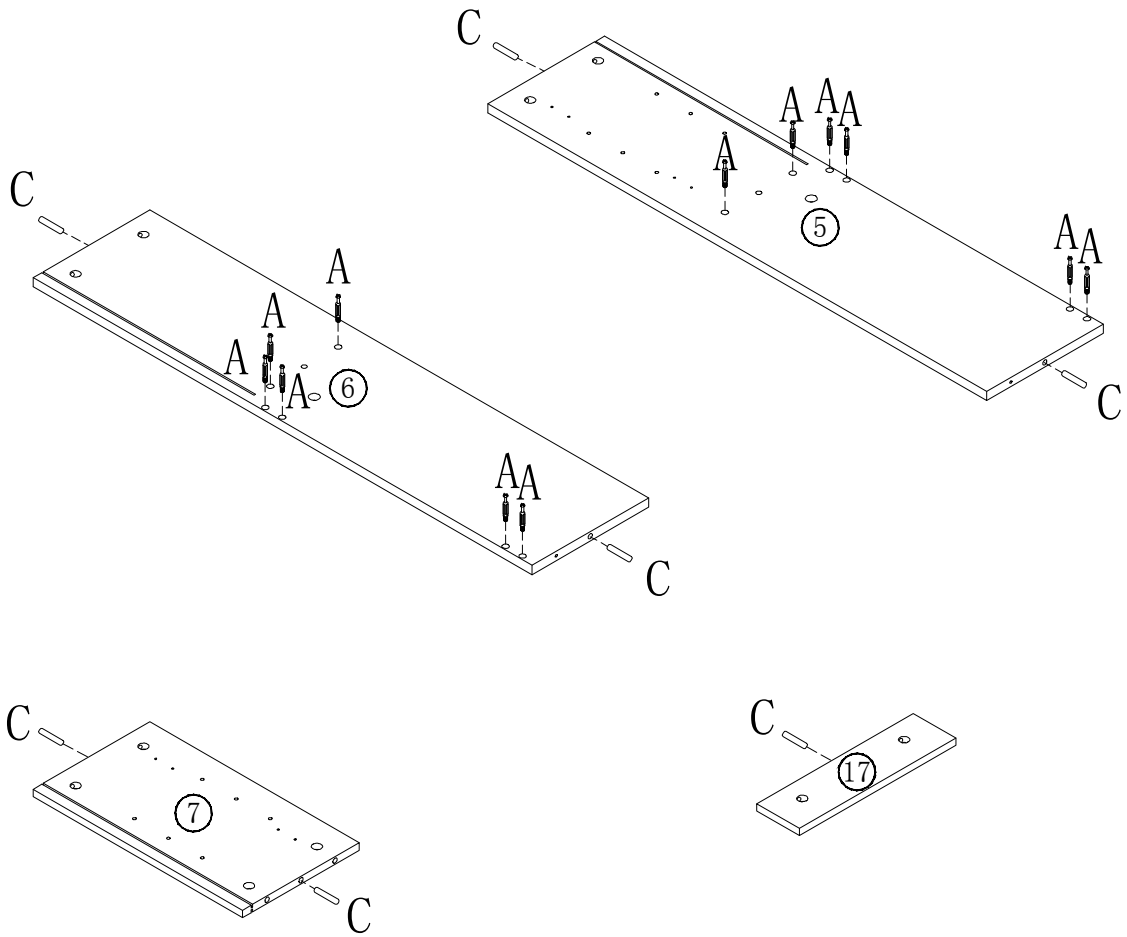
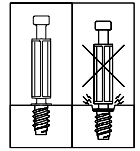
<p>②9</p>  <p>1</p>	
<p>③1</p>  <p>1</p>	
 <p>Hardware kit</p> <p>1</p>	

Step 1



			
Cam Bolt x 12		Wooden tenon x 7	

Step 2

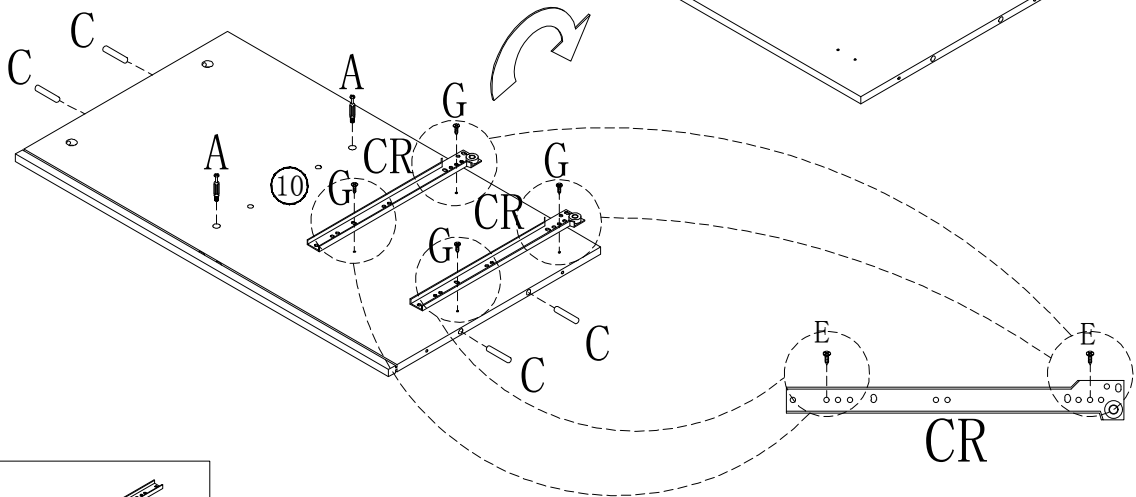
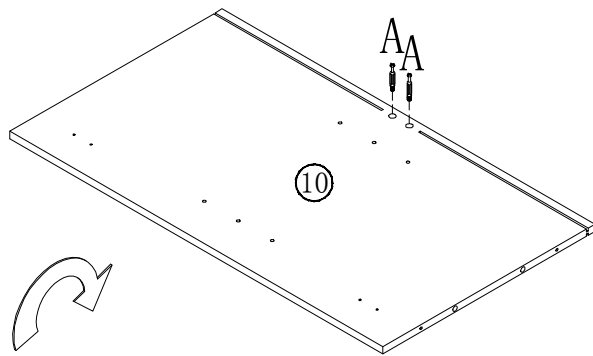
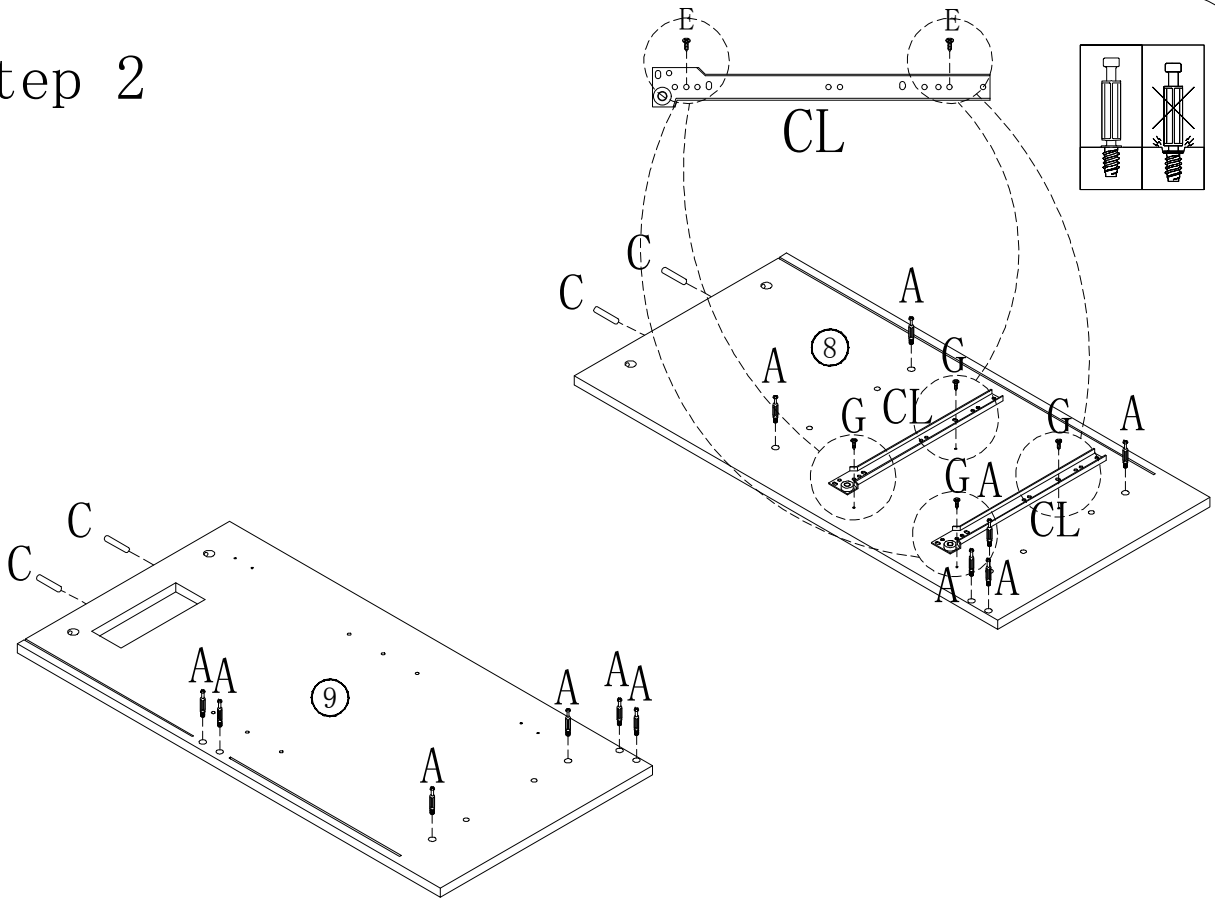

CL

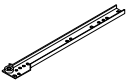

Runner 300mm x 2

(A)



Cam Bolt x 16

(C)

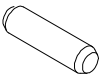

Wooden tenon x 8

(G)



3.5*14 self-tapping x 8

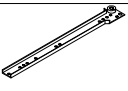

CR



Runner 300mm x 2

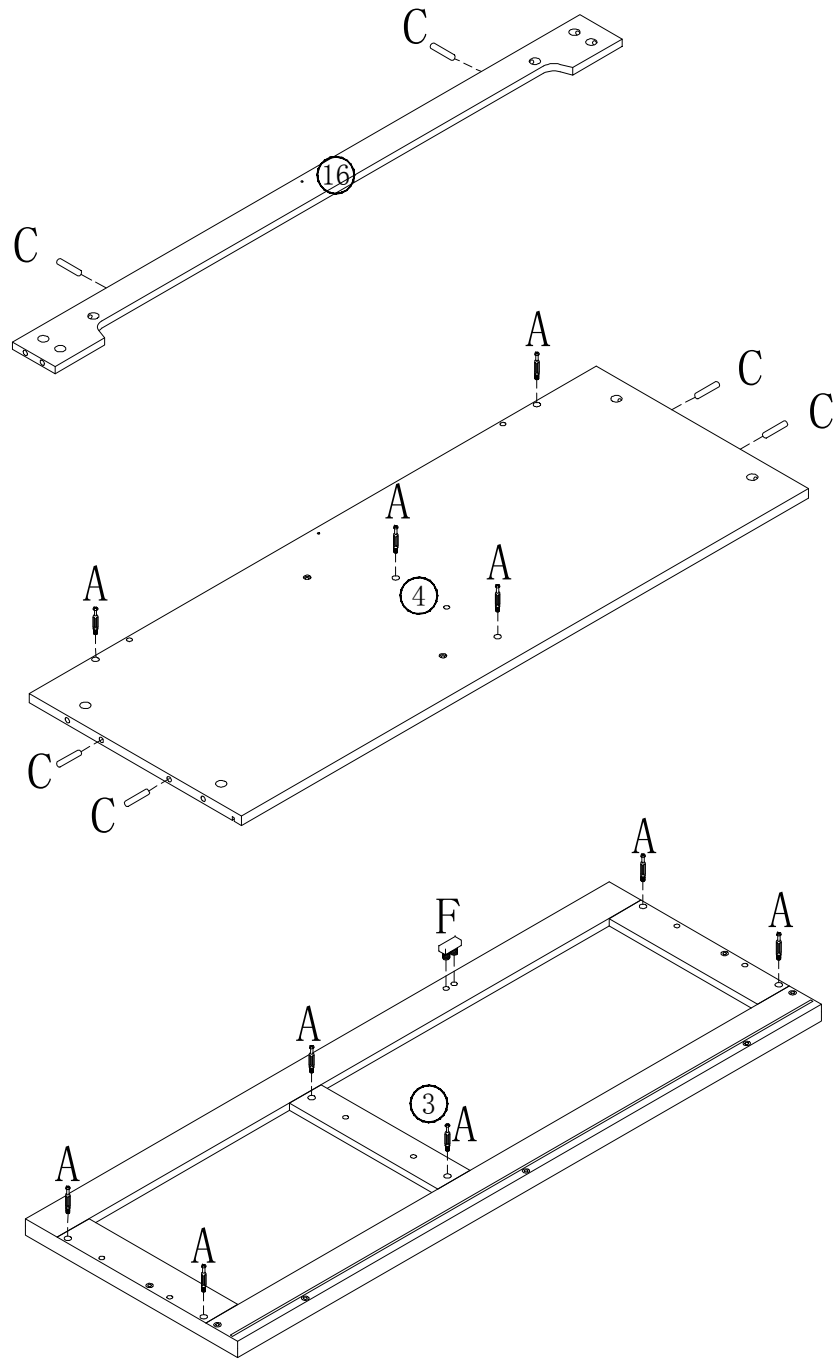
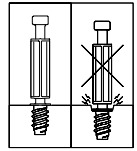

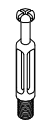
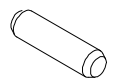

Step 3

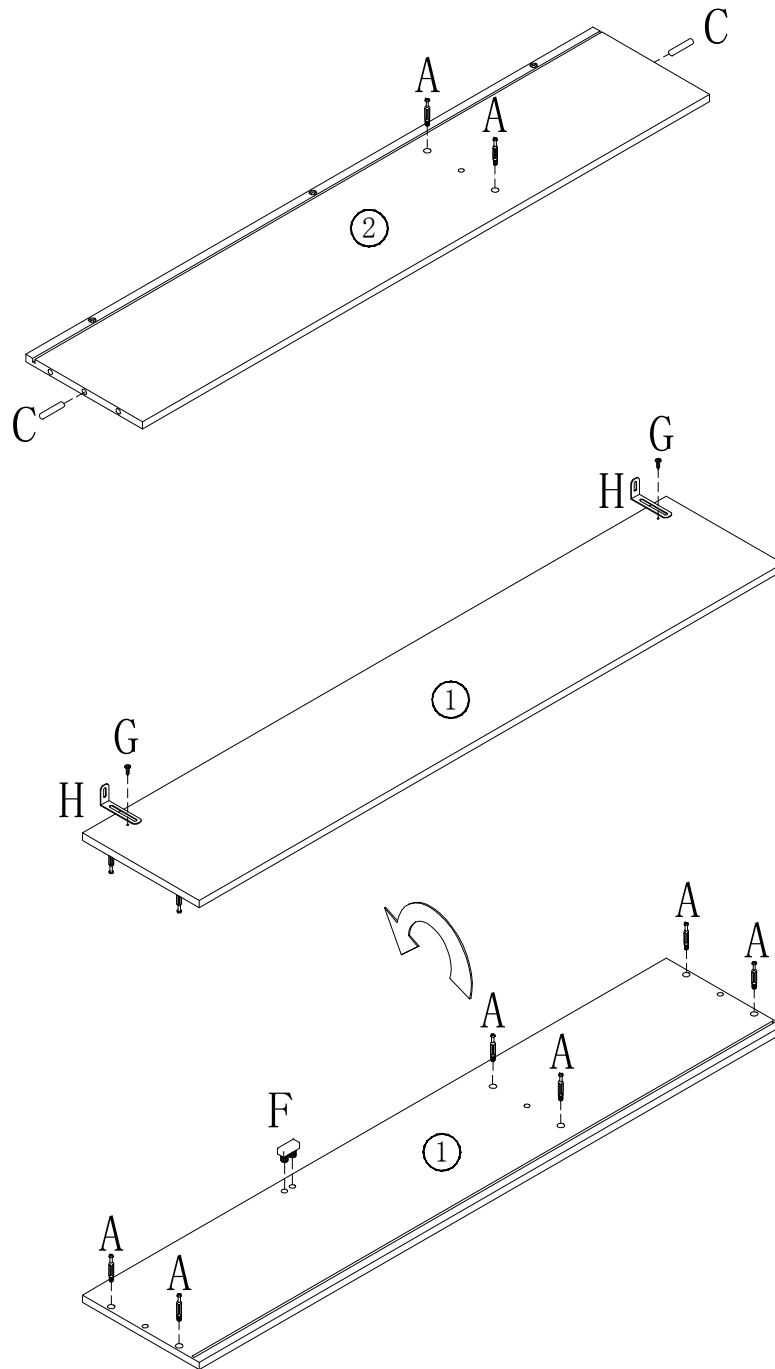
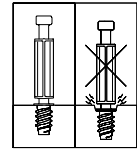

<p>(A)</p>  <p>Cam Bolt x 10</p>	<p>(C)</p>  <p>Wooden tenon x 6</p>	<p>(F)</p>  <p>door stop x 1</p>
---	--	--

Step 4

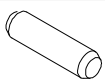

<p>(F)  door stop x 1</p>	<p>(G)  3.5*14 self-tapping x 2</p>
<p>(H)  Anti toppling angle iron x 2</p>	<p>(A)  Cam Bolt x 8</p> <p>(C)  Wooden tenon x 2</p>

Step 5

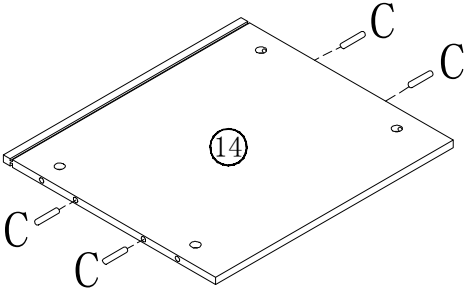
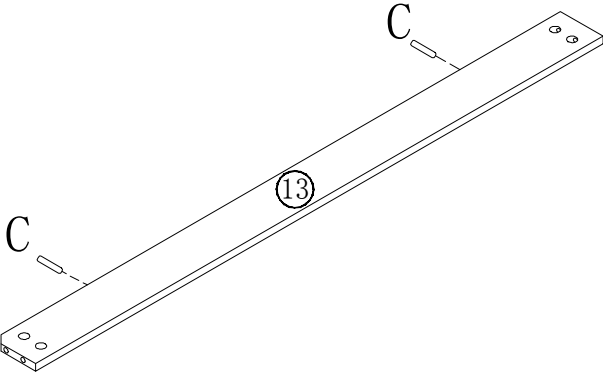
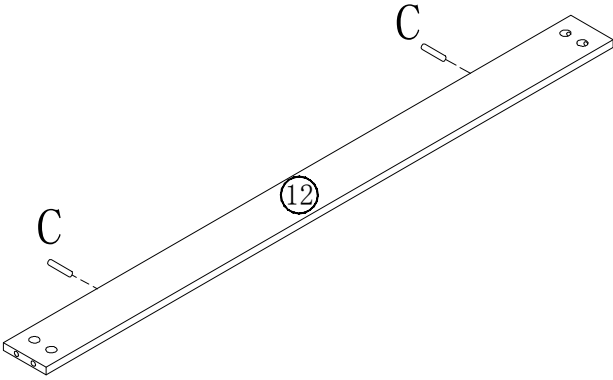

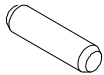
C 
Wooden tenon x 8

Step 6

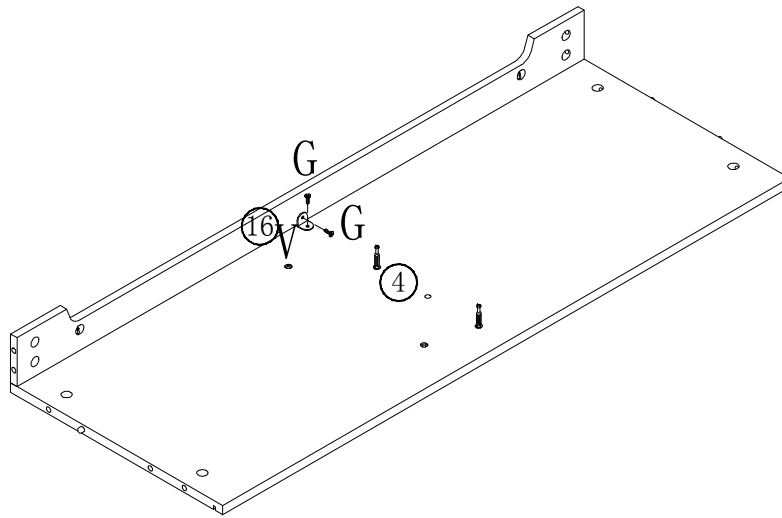
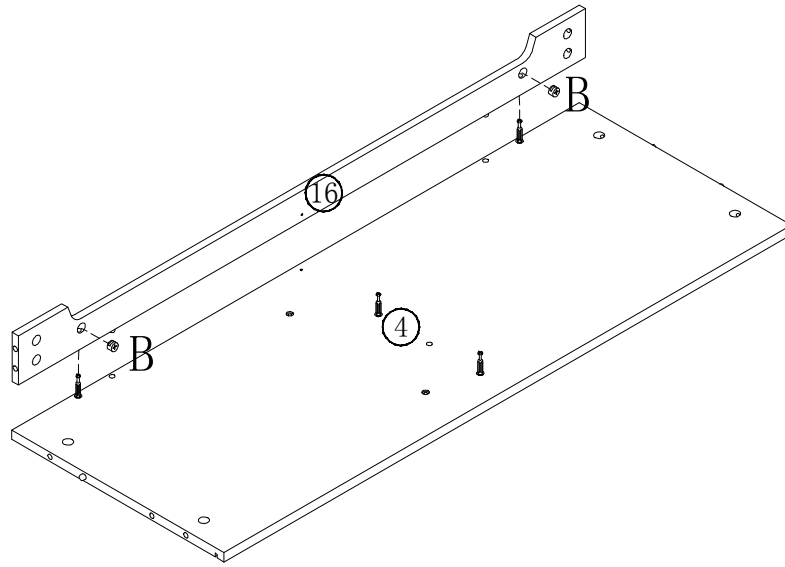

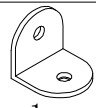
<p>G 3.5*14 self-tapping x 2</p>	
<p>B Cam Lock 15 Plate thick x 2</p>	<p>V angle iron x 1</p> 

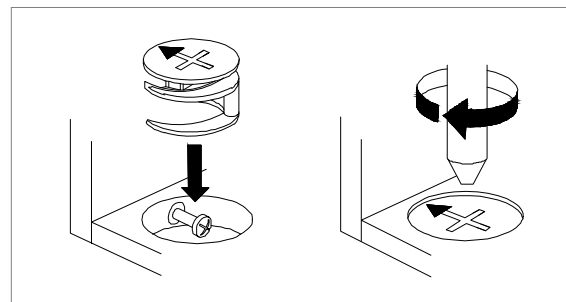

Step 7

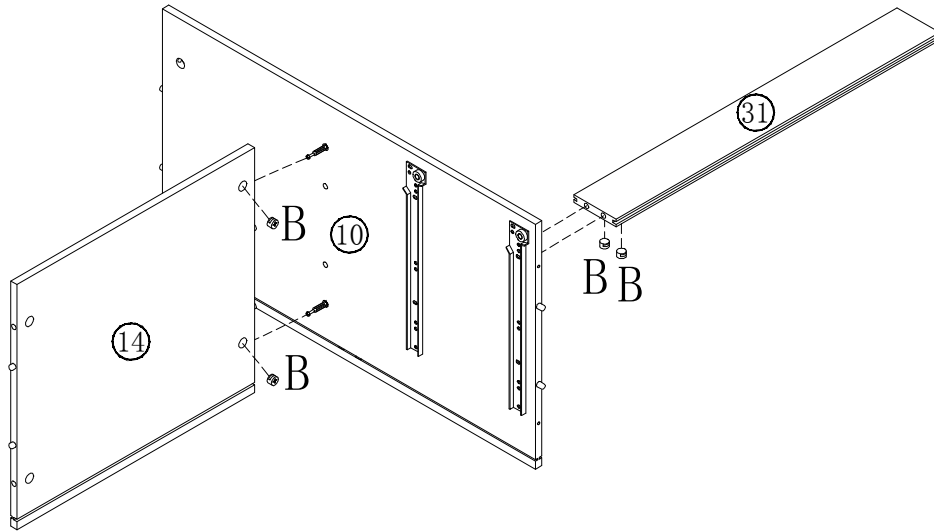
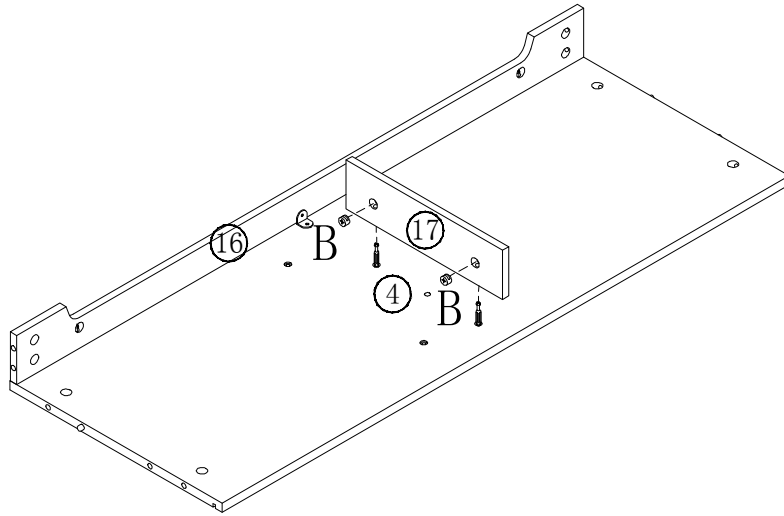

(B) 
Cam Lock
15 Plate thick x6

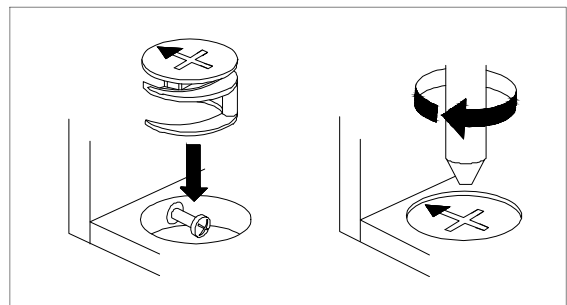

Step 8

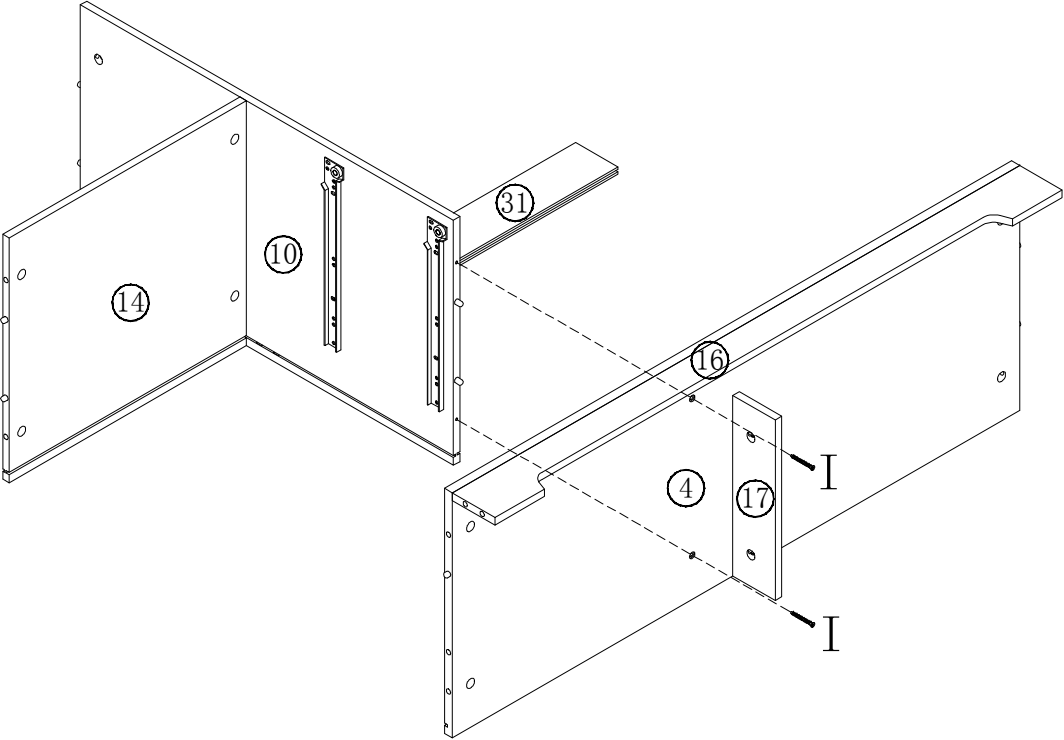

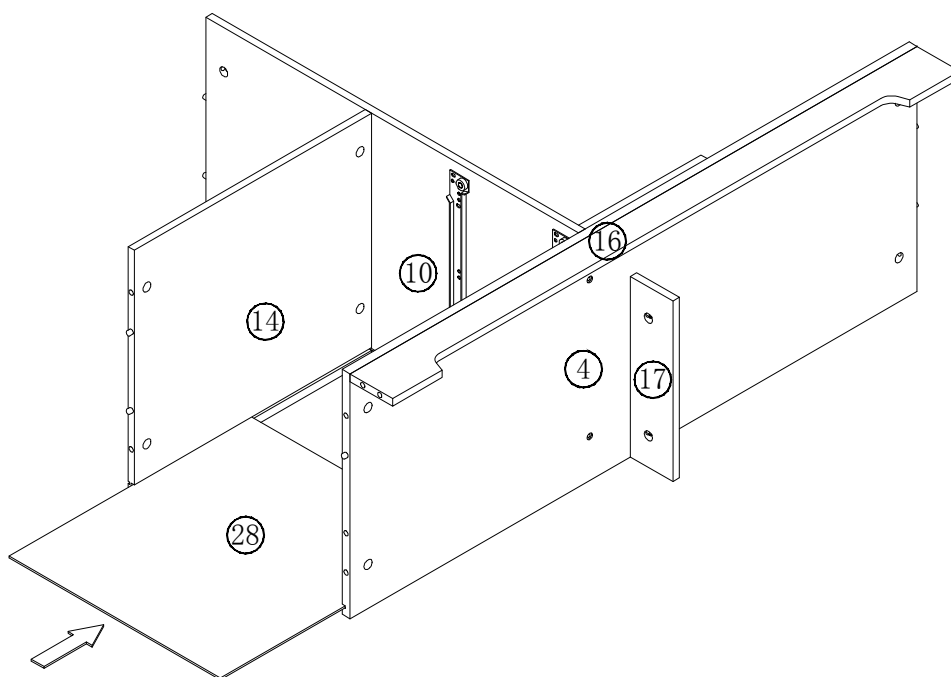

I
5*40 Wood
tooth screw x2

Step 9

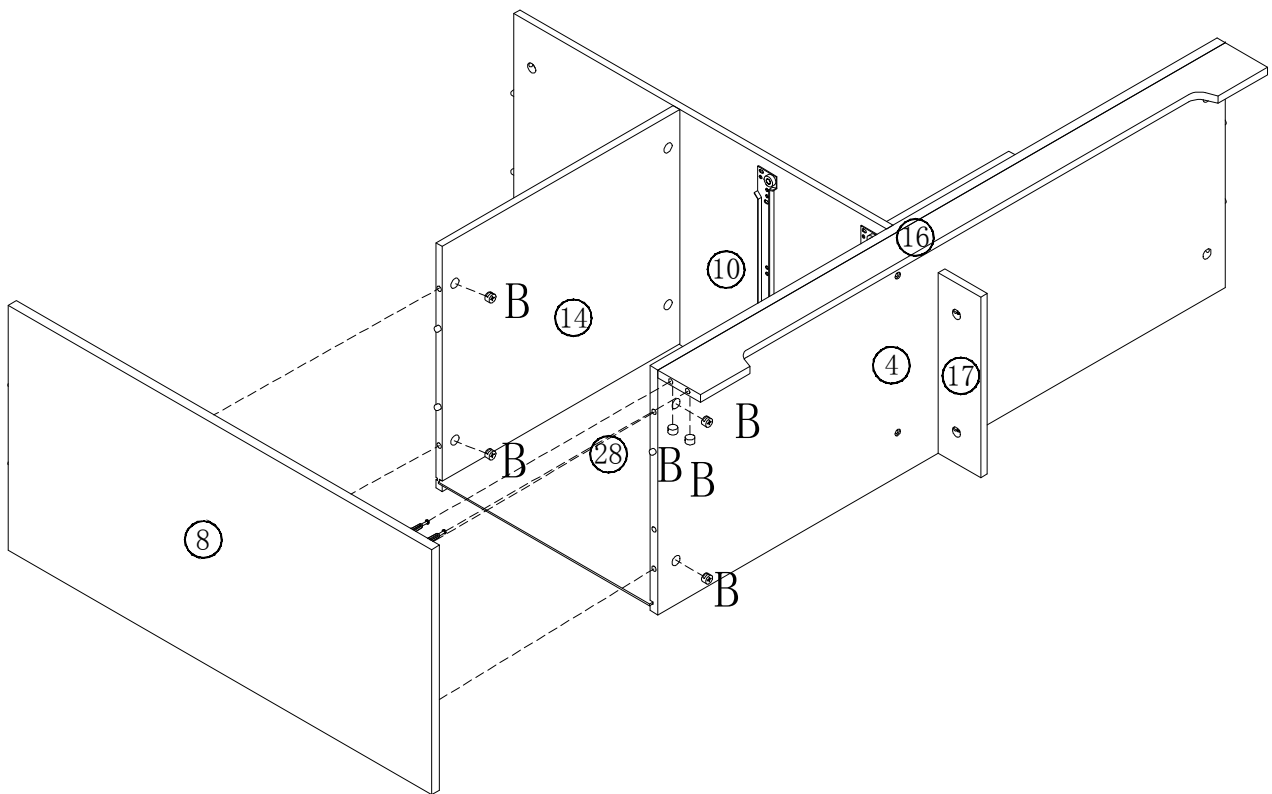

Step 10



(B) 
Cam Lock
15 Plate thick x 6

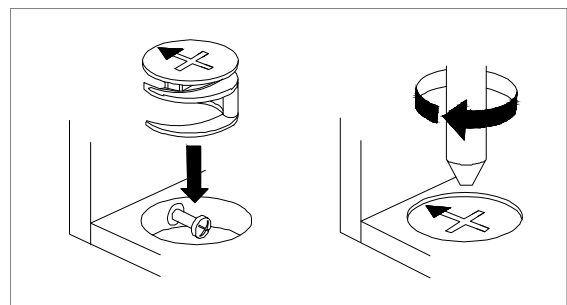

Step 11

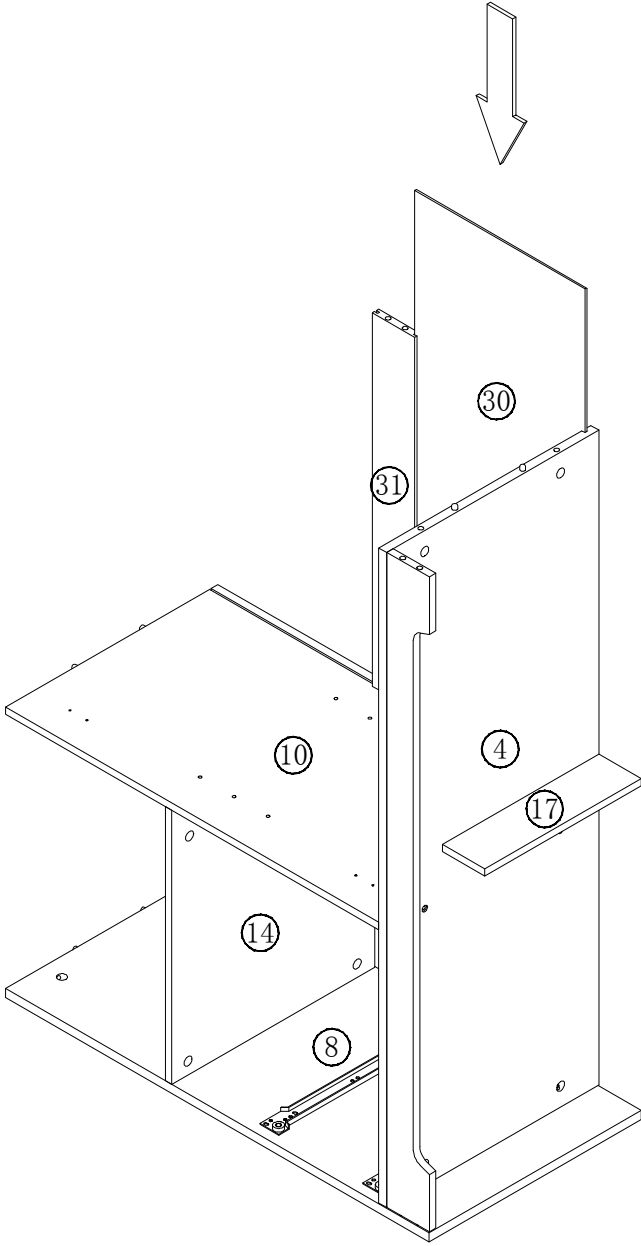

Step 12

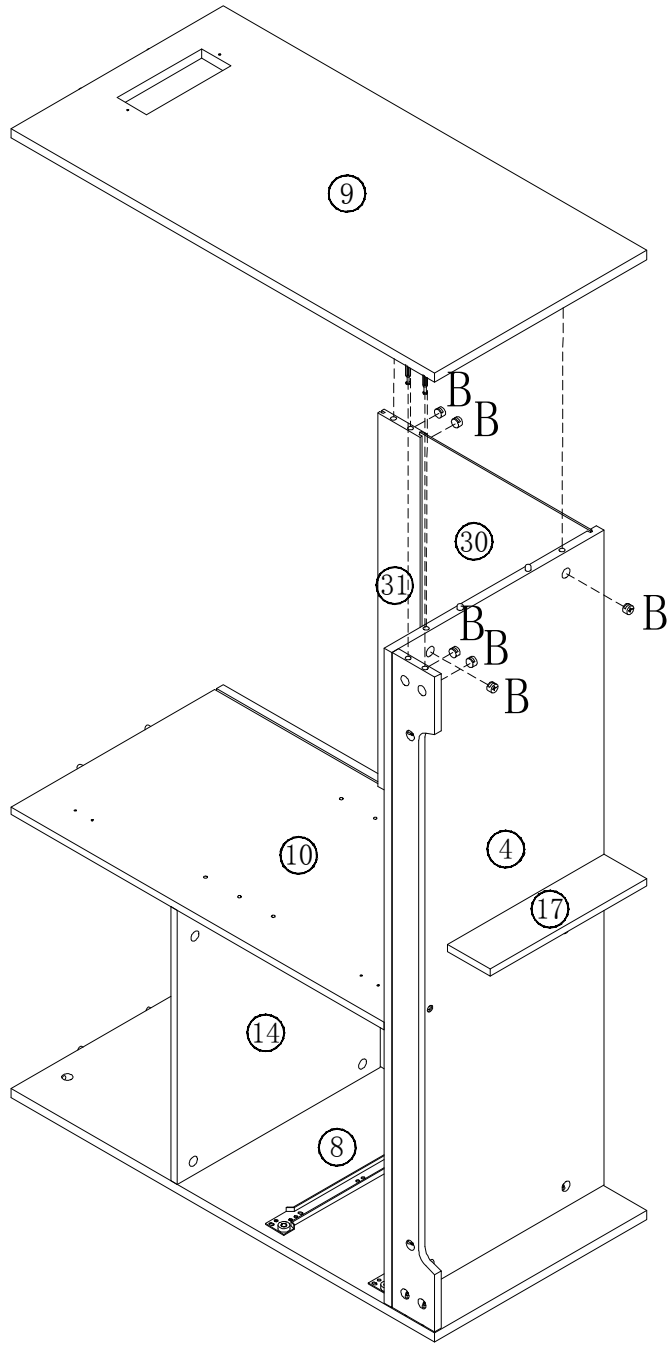

(B) 
Cam Lock
15 Plate thick x 6

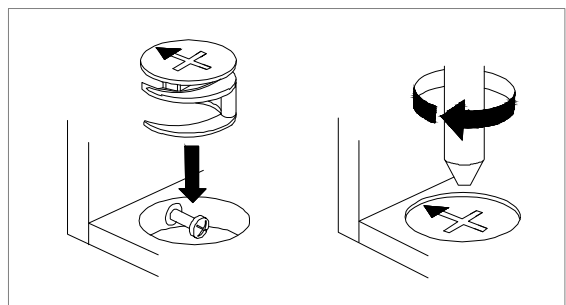

Step 13

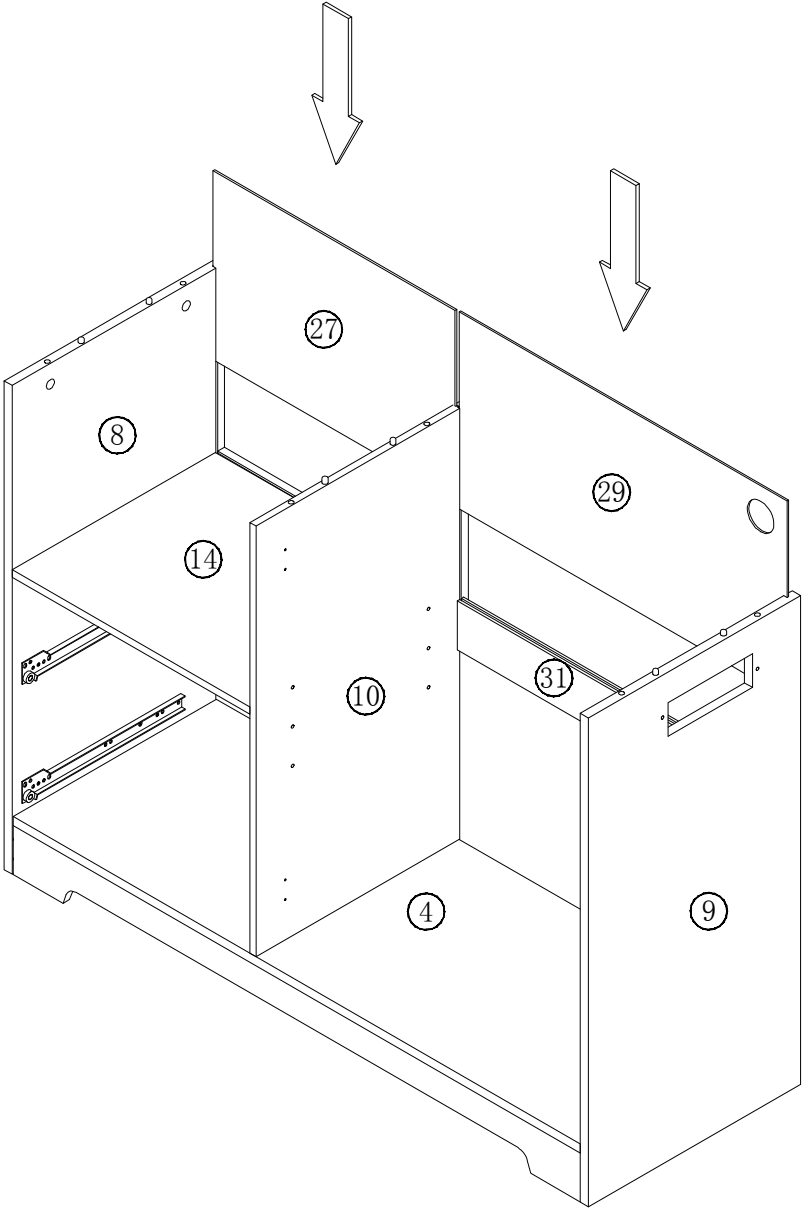

Step 14

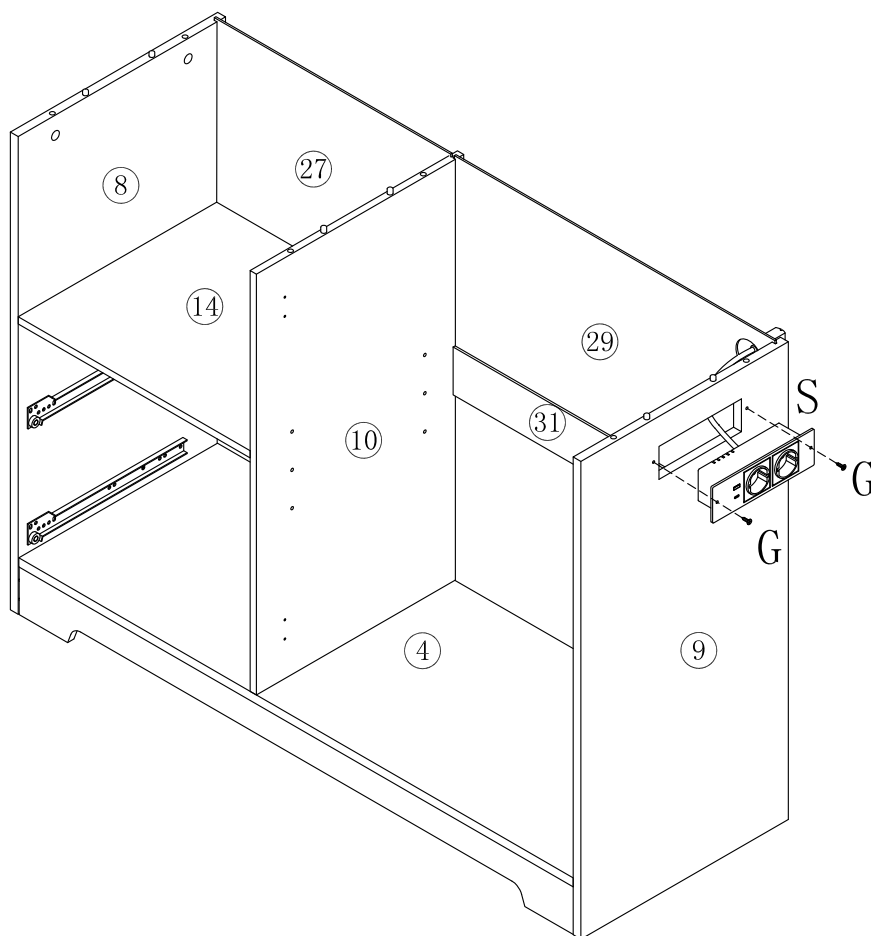

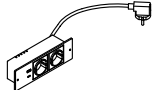
G 3.5*14 self-tapping x 2		S  power strip x1
--	---	---

Step 15

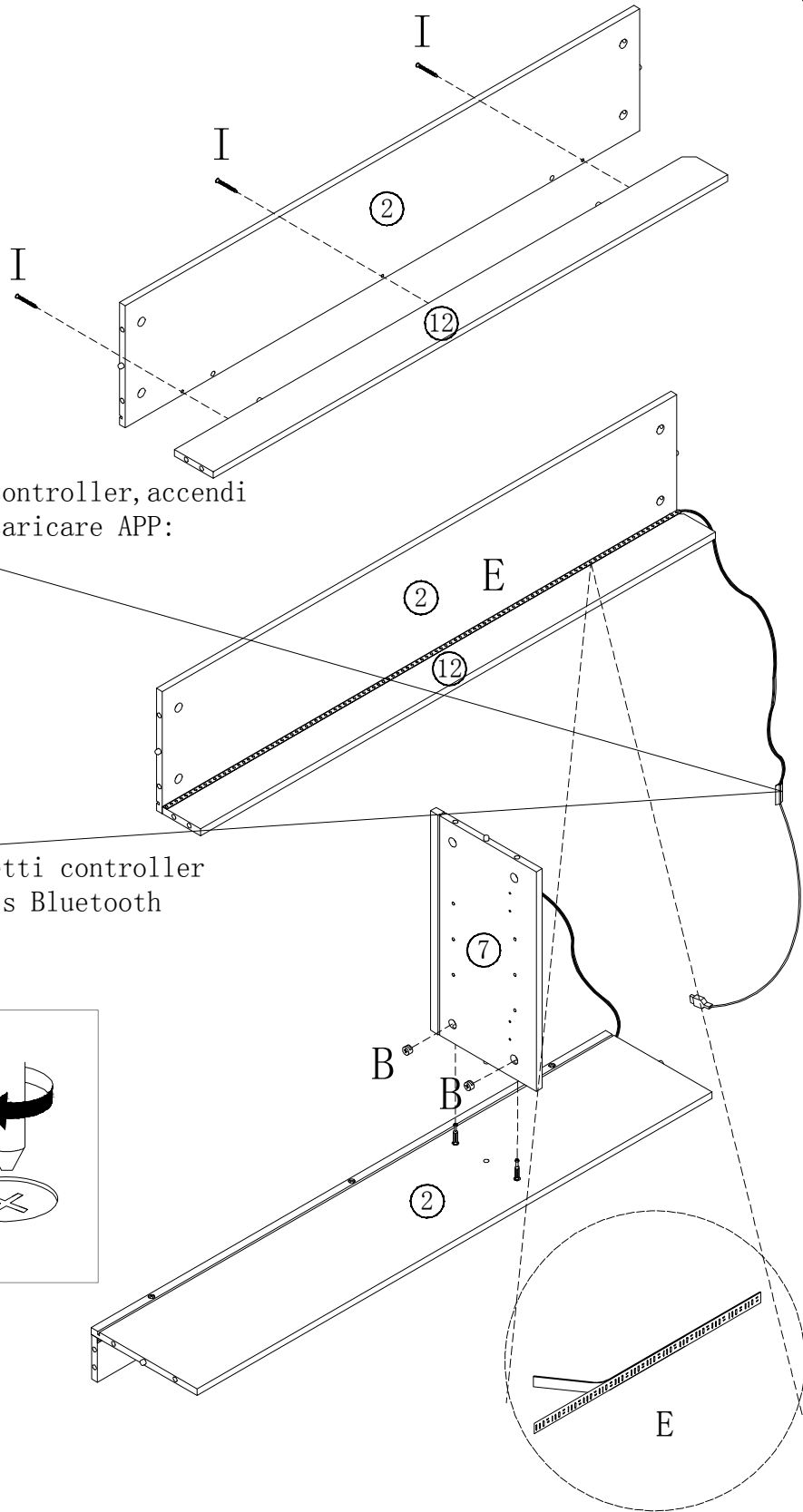



PASSI CONNESSIONE

- ① Collega striscia LED & controller, accendi
- ② Scansiona QR code per scaricare APP:



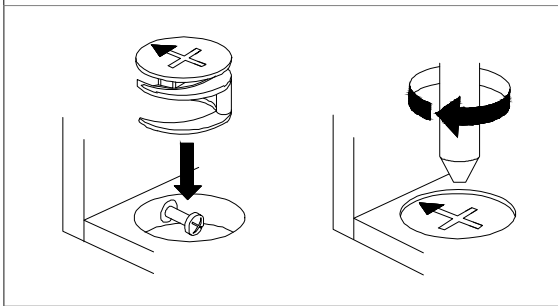

- ③ Avvia APP, cerca & connetti controller
- ④ Goditi controllo wireless Bluetooth

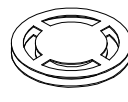
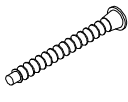

<p>(B)  Cam Lock 15 Plate thick x 2</p>	<p>(E)  LED strip x1</p>	<p>(I)  5*40 Wood tooth screw x 3</p>
--	---	---

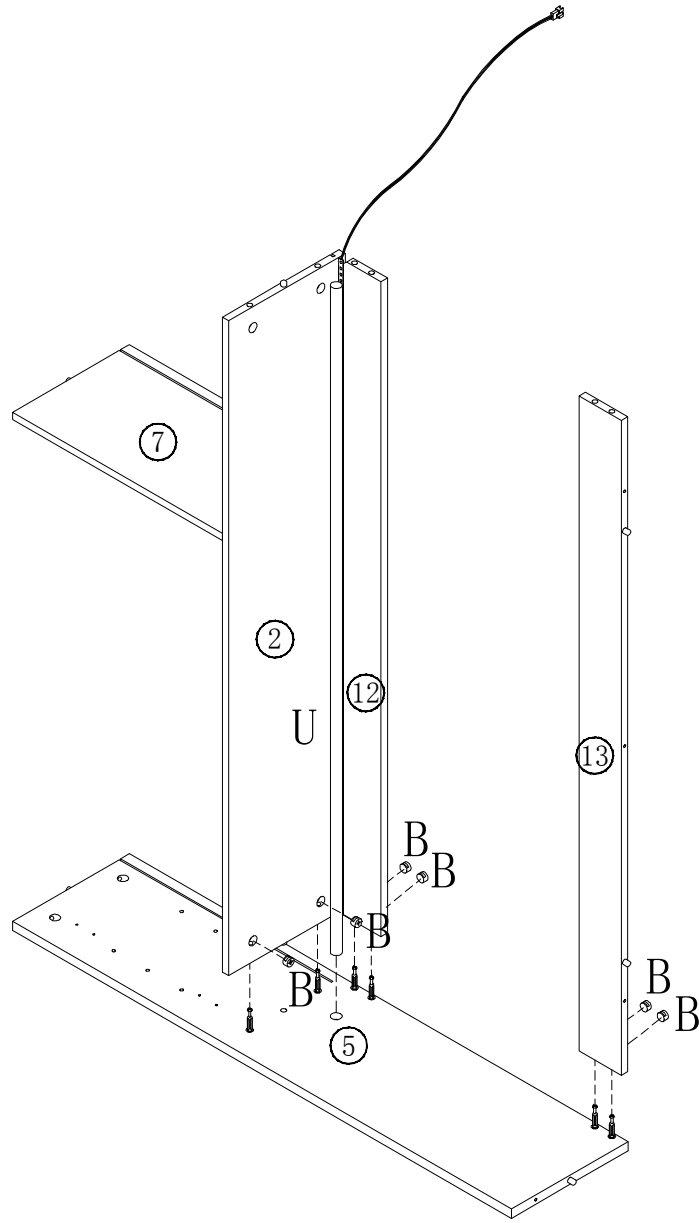
Step 16



(B)		(U)	
Cam Lock		15 Plate thick x 6 iron pipe x 1	

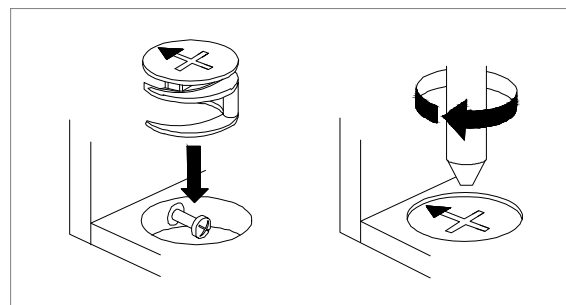

Step 17

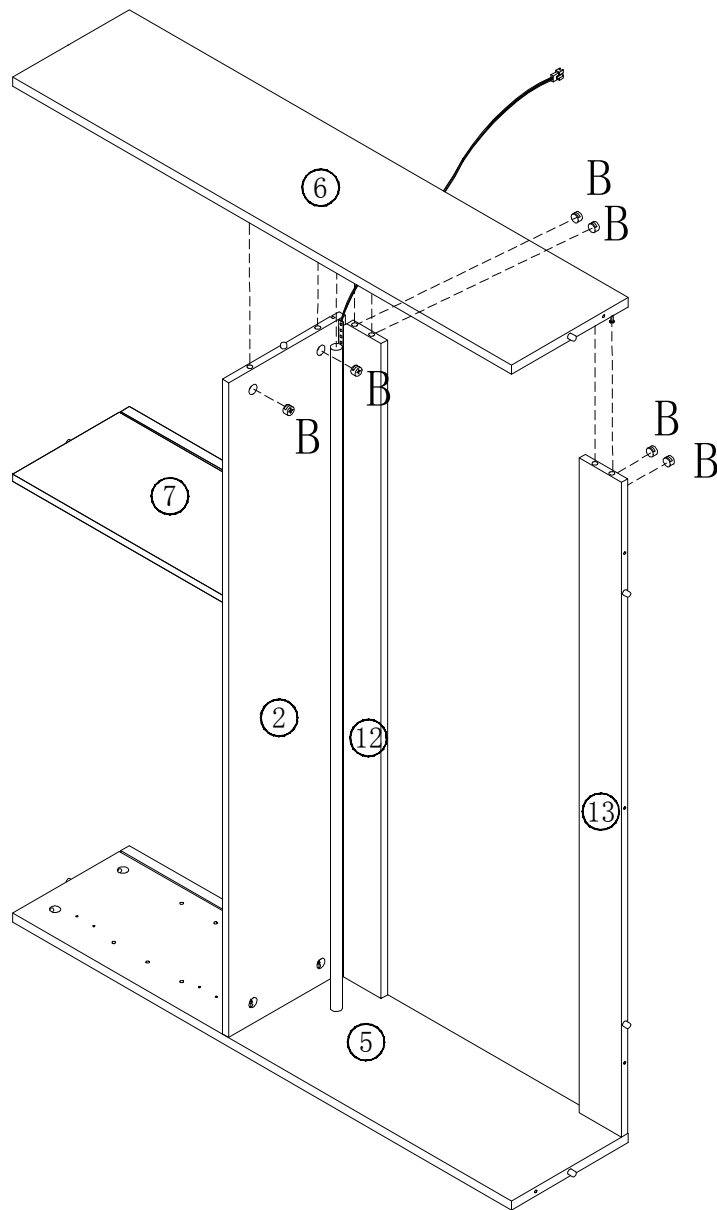

(B) 
Cam Lock
15 Plate thick x 6

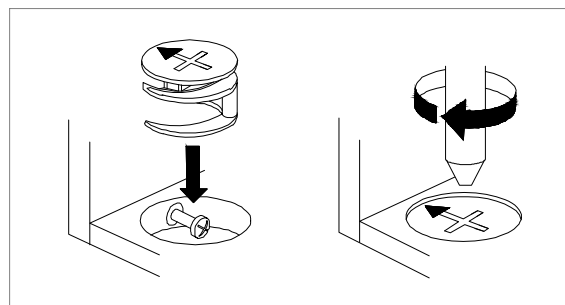

Step 18

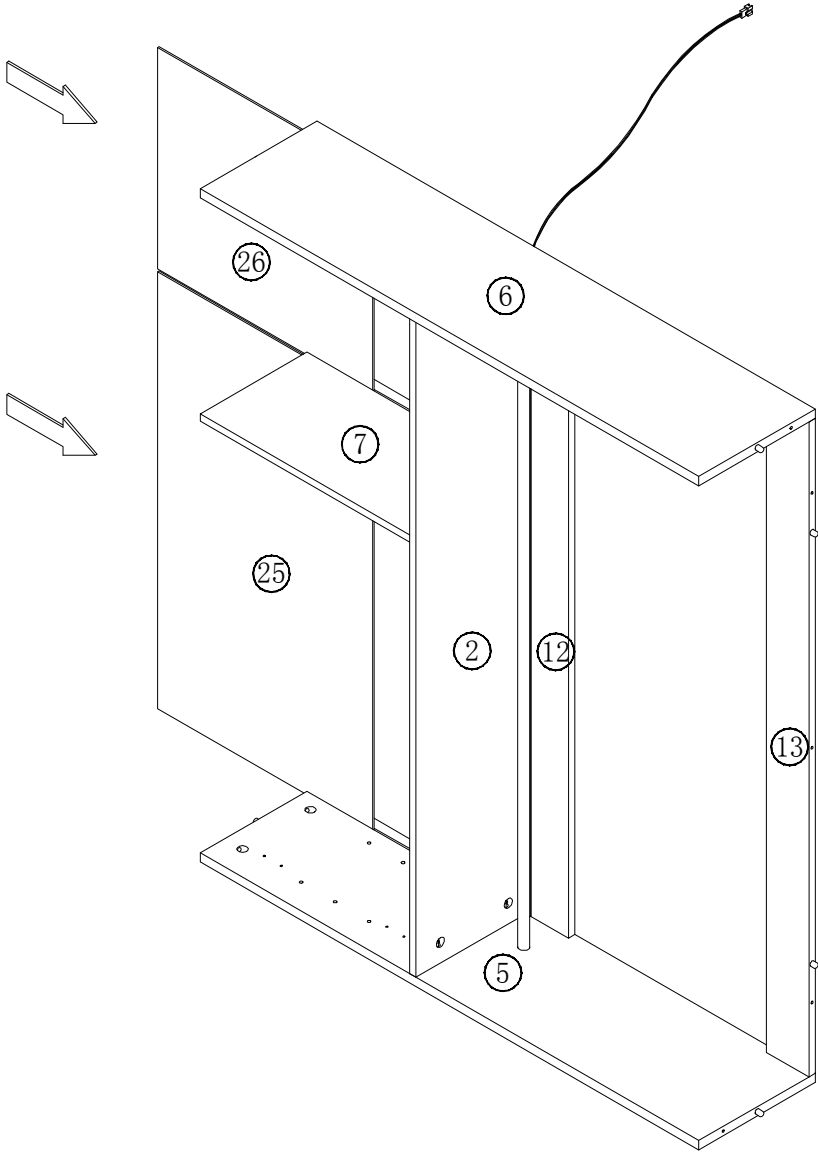

Step 19

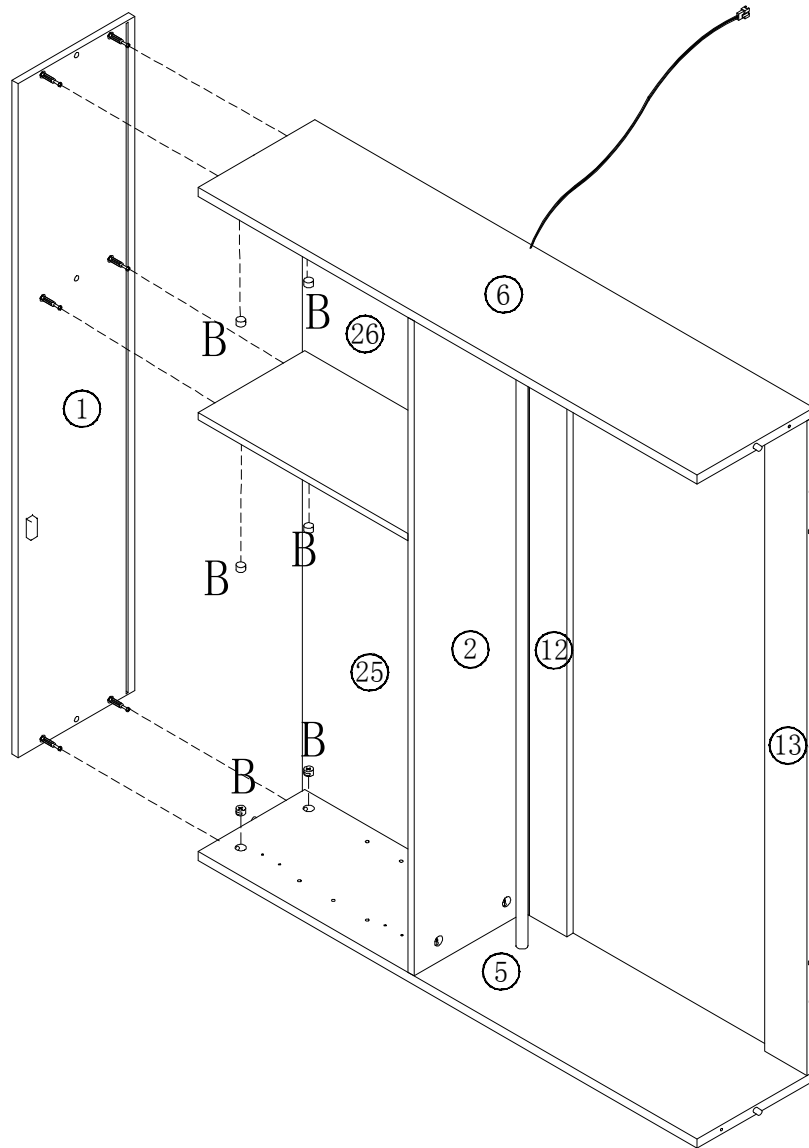

(B) 
Cam Lock
15 Plate thick x 6

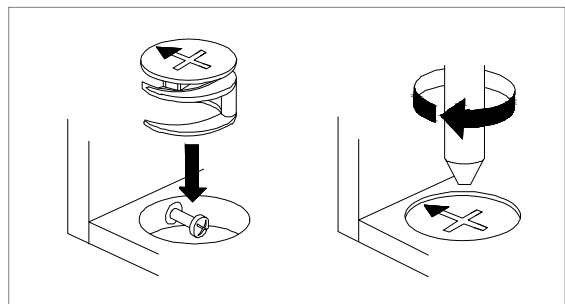

Step 20

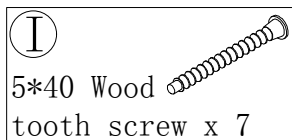
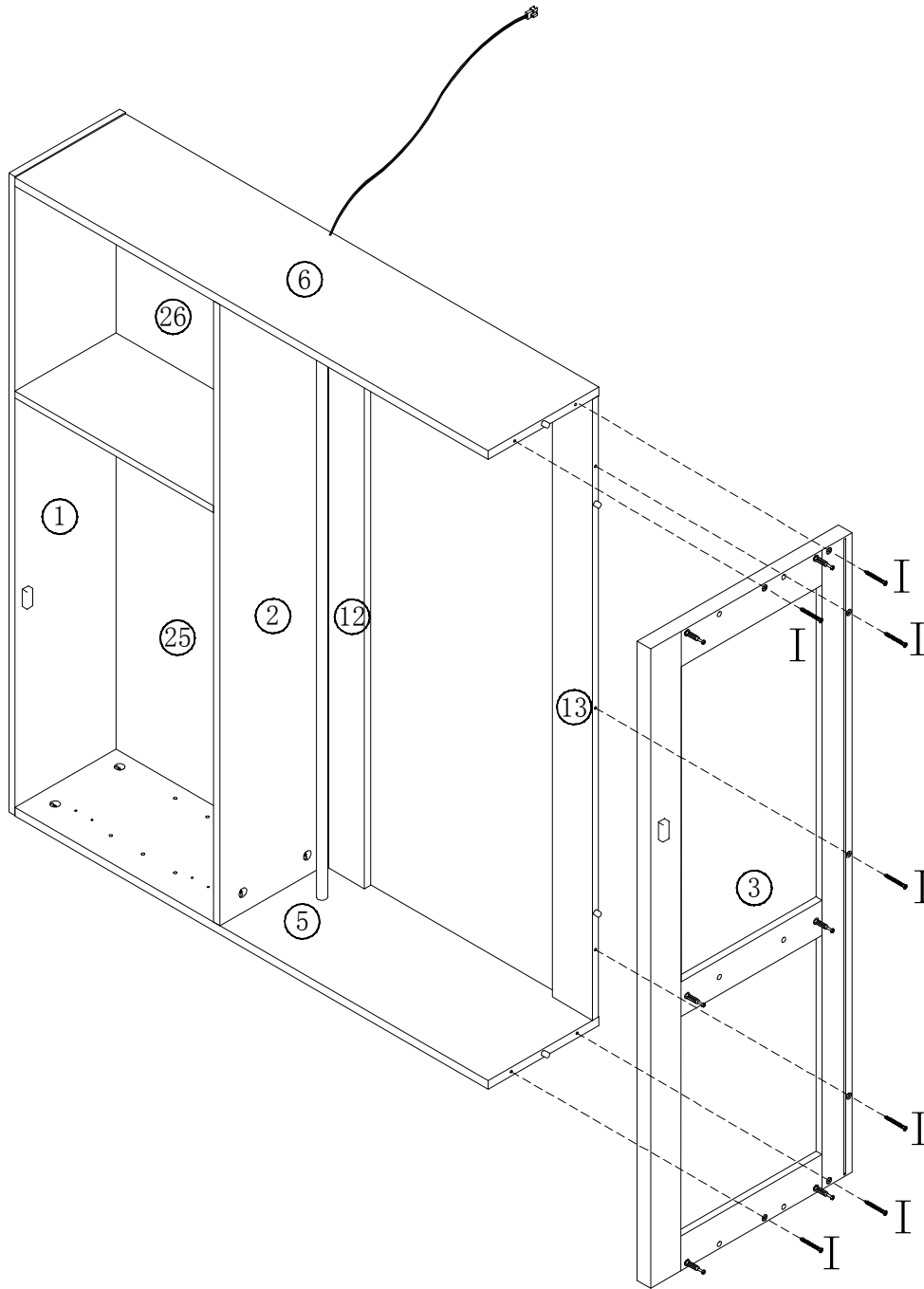

Step 21

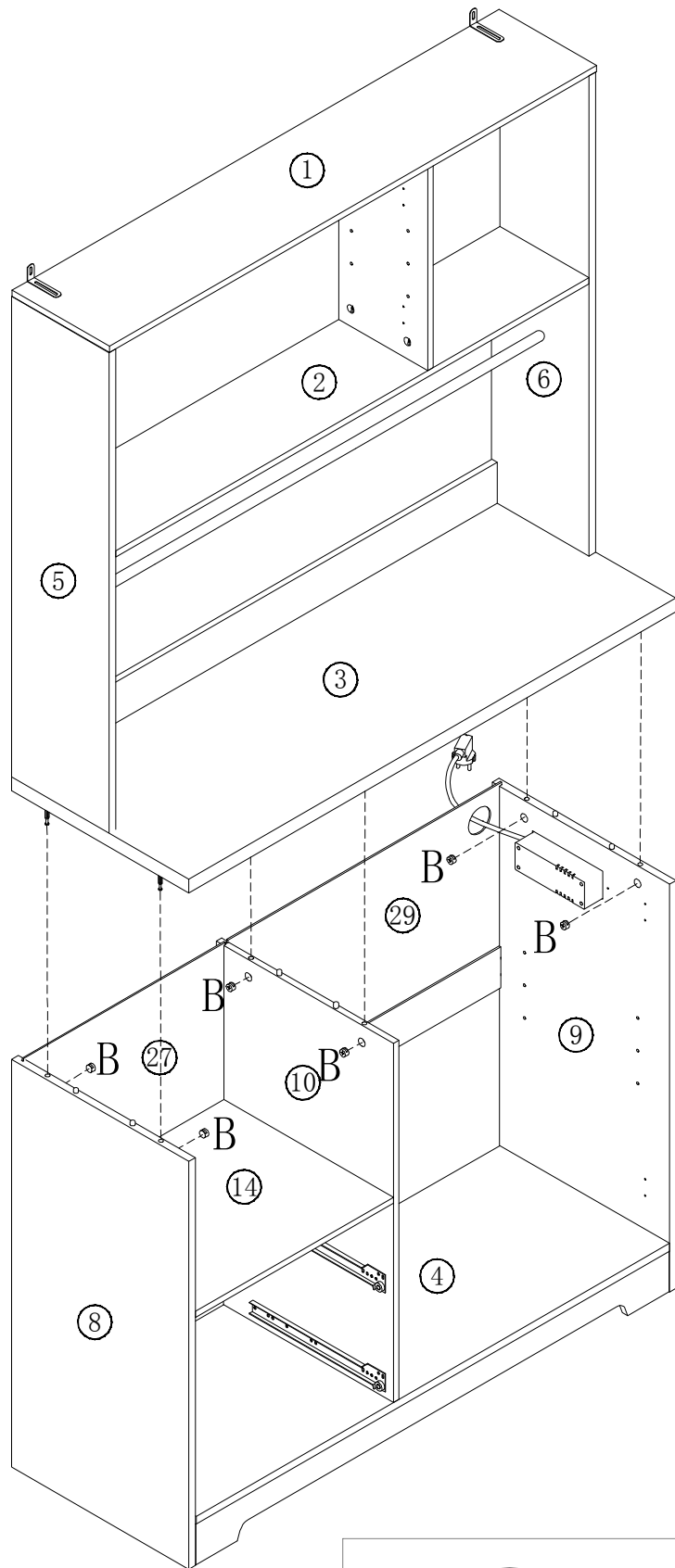

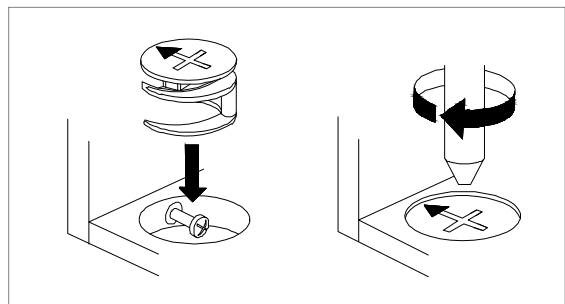

(B) 
Cam Lock
15 Plate thick x 6

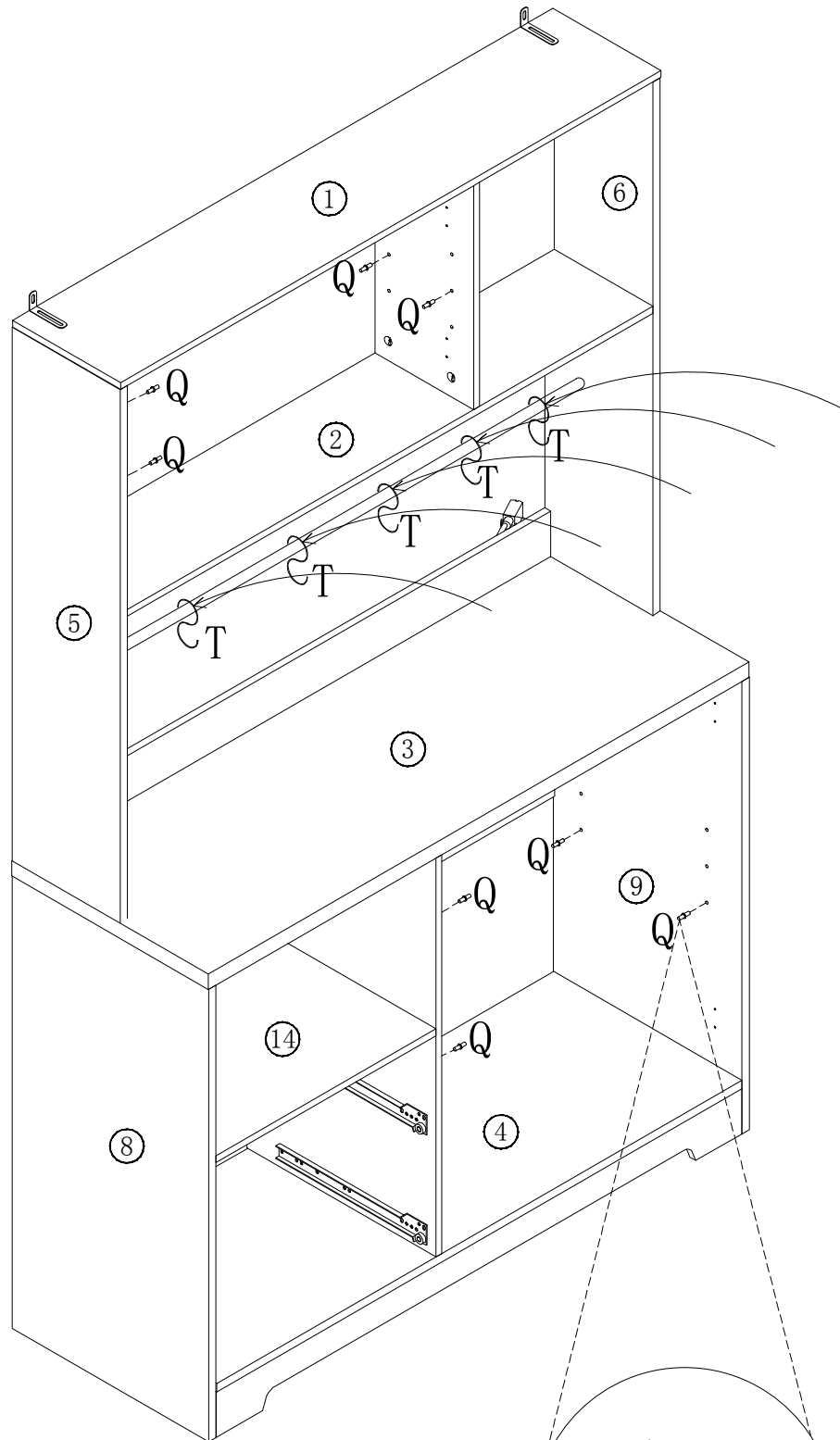

Step 22



<p>(S)  Partition bracket x 8</p>	<p>(T)  power strip x5</p>
--	---

Step 23

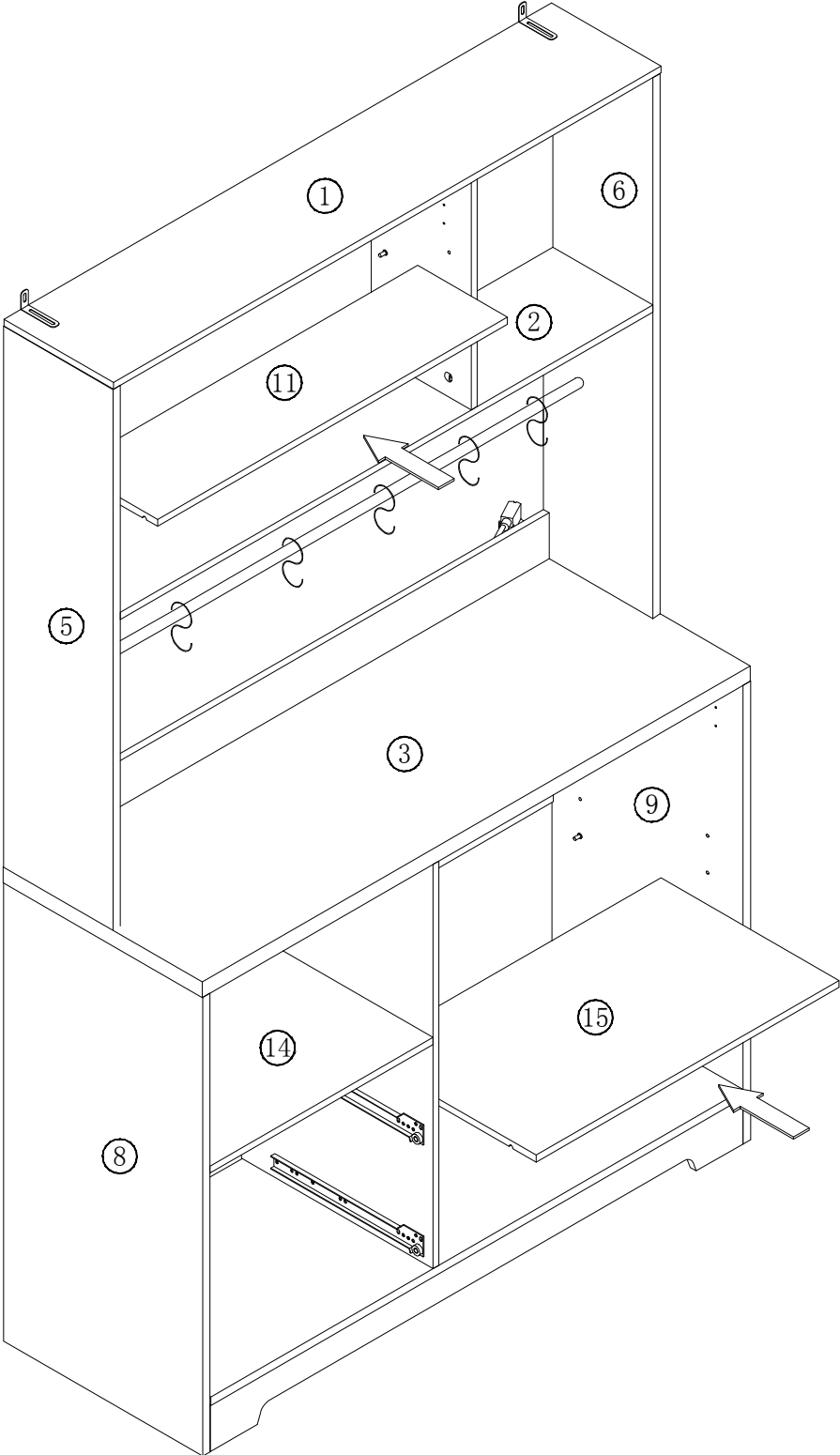

Step 24

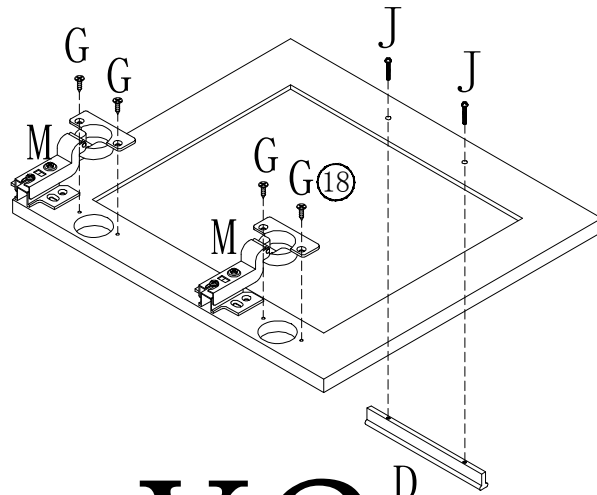

X2^D

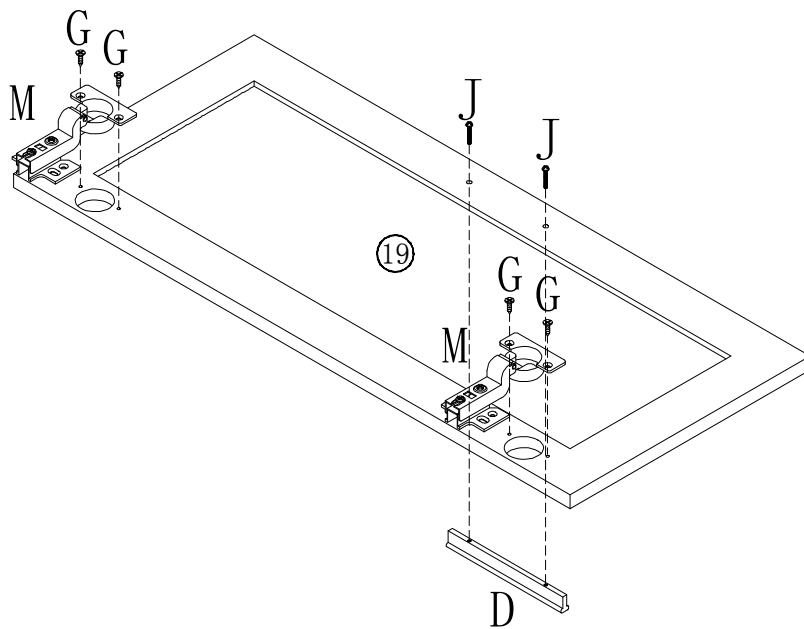

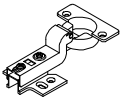
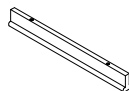
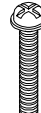
<p>G 3.5*14 self-tapping x 16</p> 	<p>M Hinge x 8</p> 	<p>D turntable x 4</p> 	<p>J hand screw x 8</p> 
--	---	--	--

Step 25

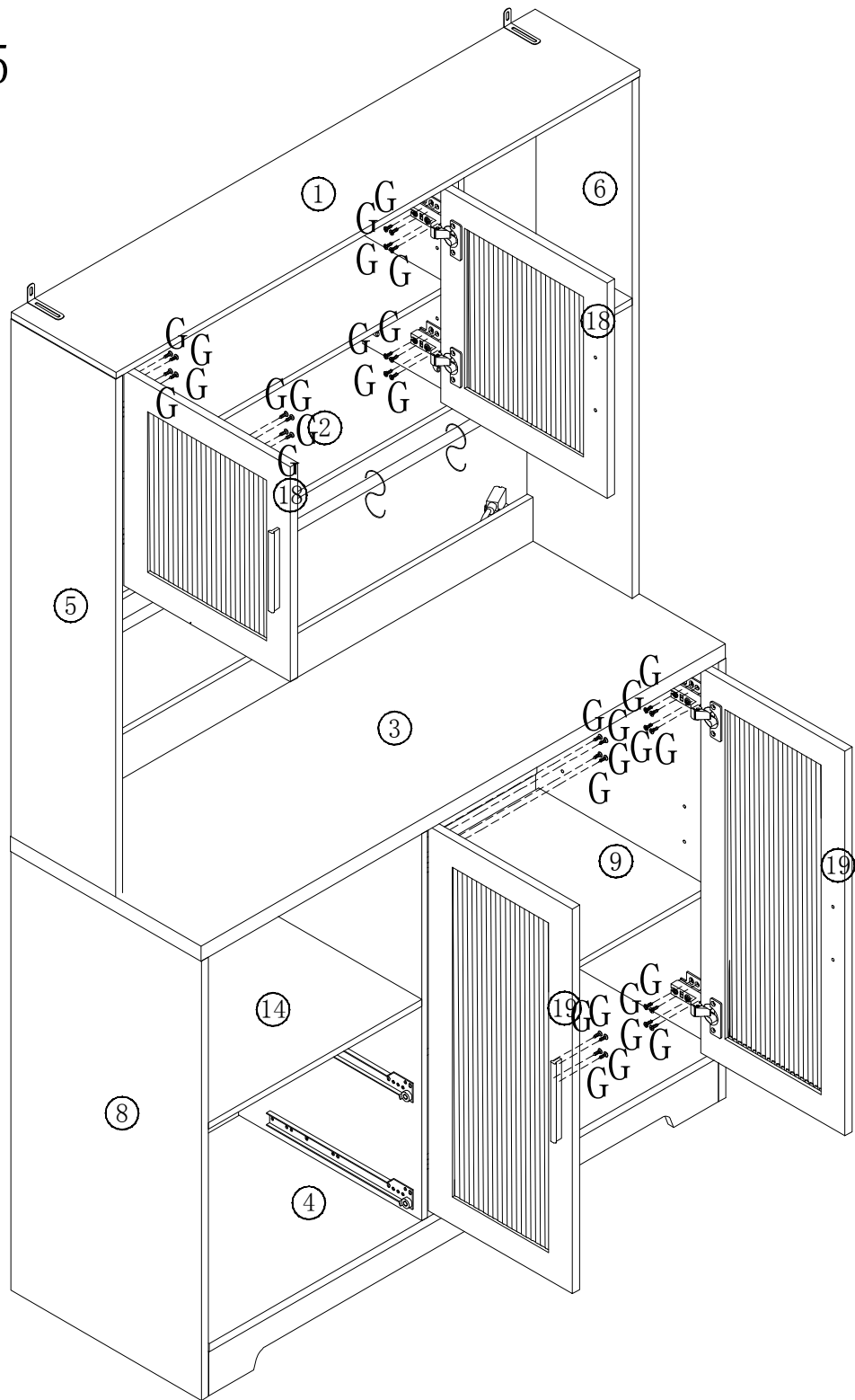







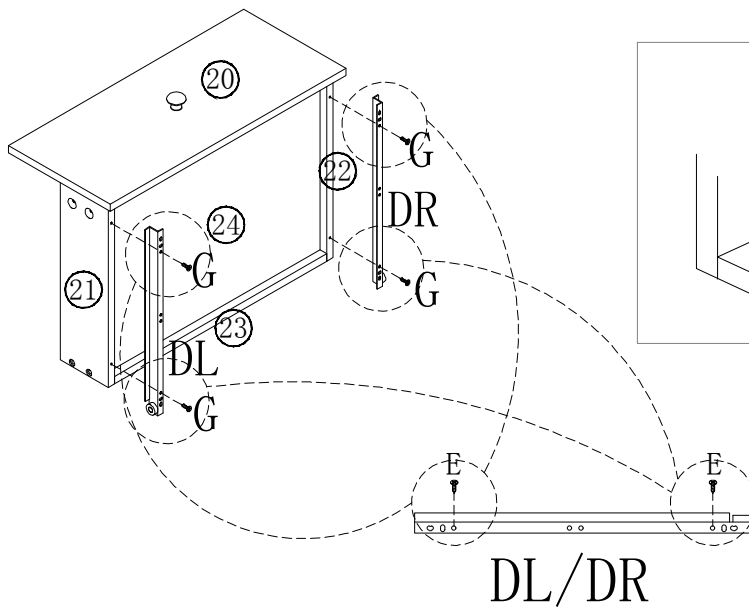
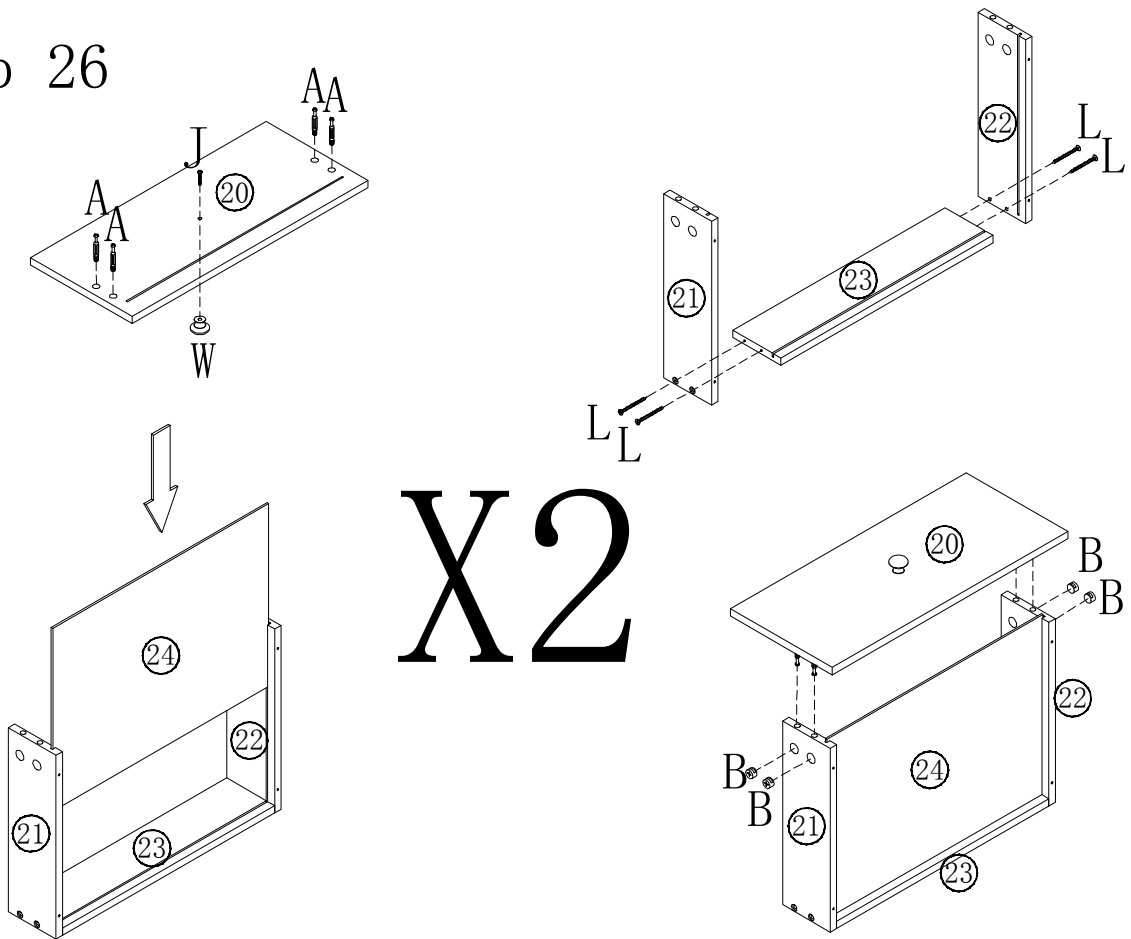

G
3.5*14
self-tapping x 32



Step 26



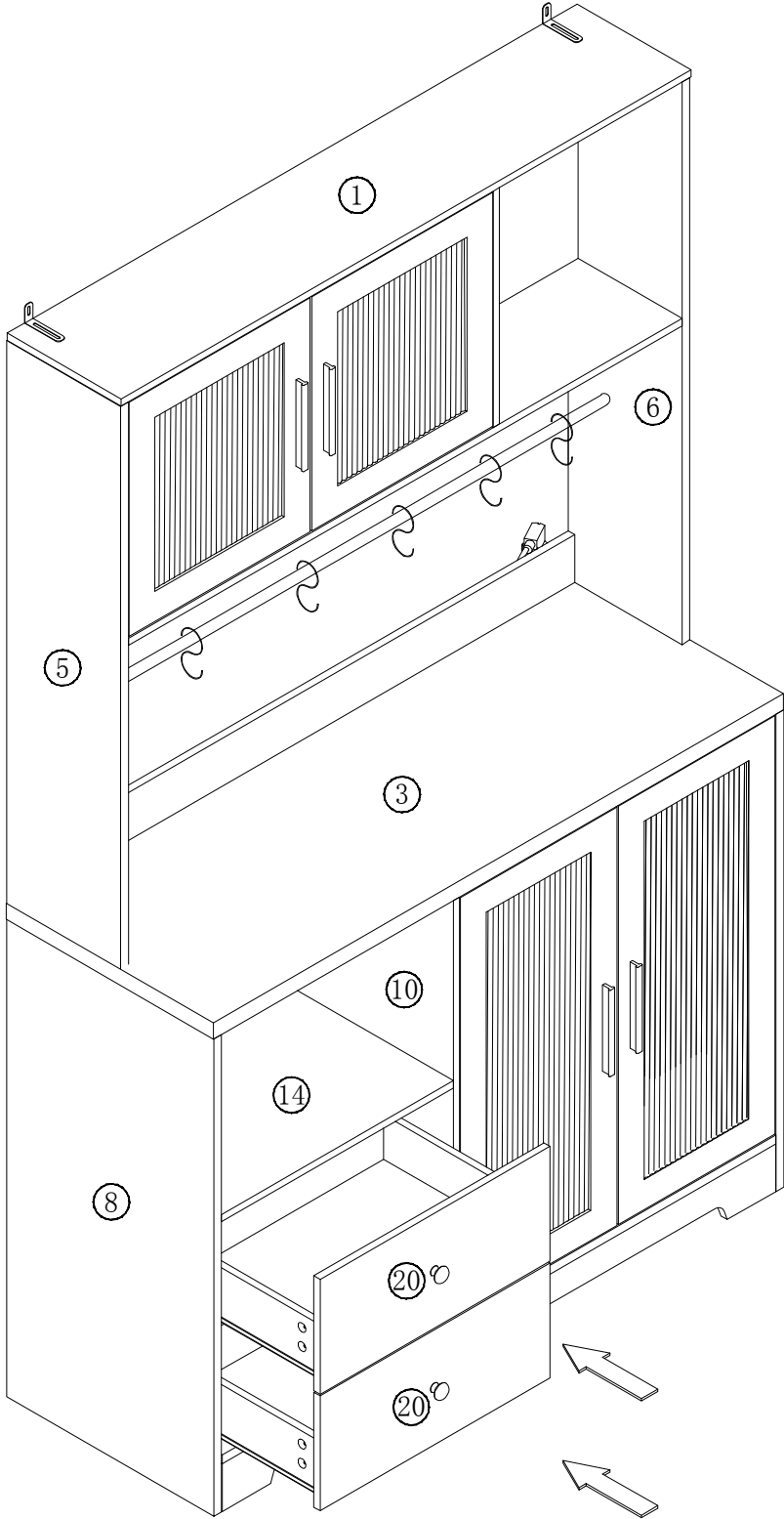

(J)  hand screw x 2	DL  Runner300mm x 2	DR  Runner300mm x 2	(L)  3.5*35 self-tapping x 8
(G)  3.5*14 self-tapping x 8	(A)  Cam Bolt x 8	(B)  Cam Lock 15 Plate thick x 8	(W)  turntable x 2

Step 27



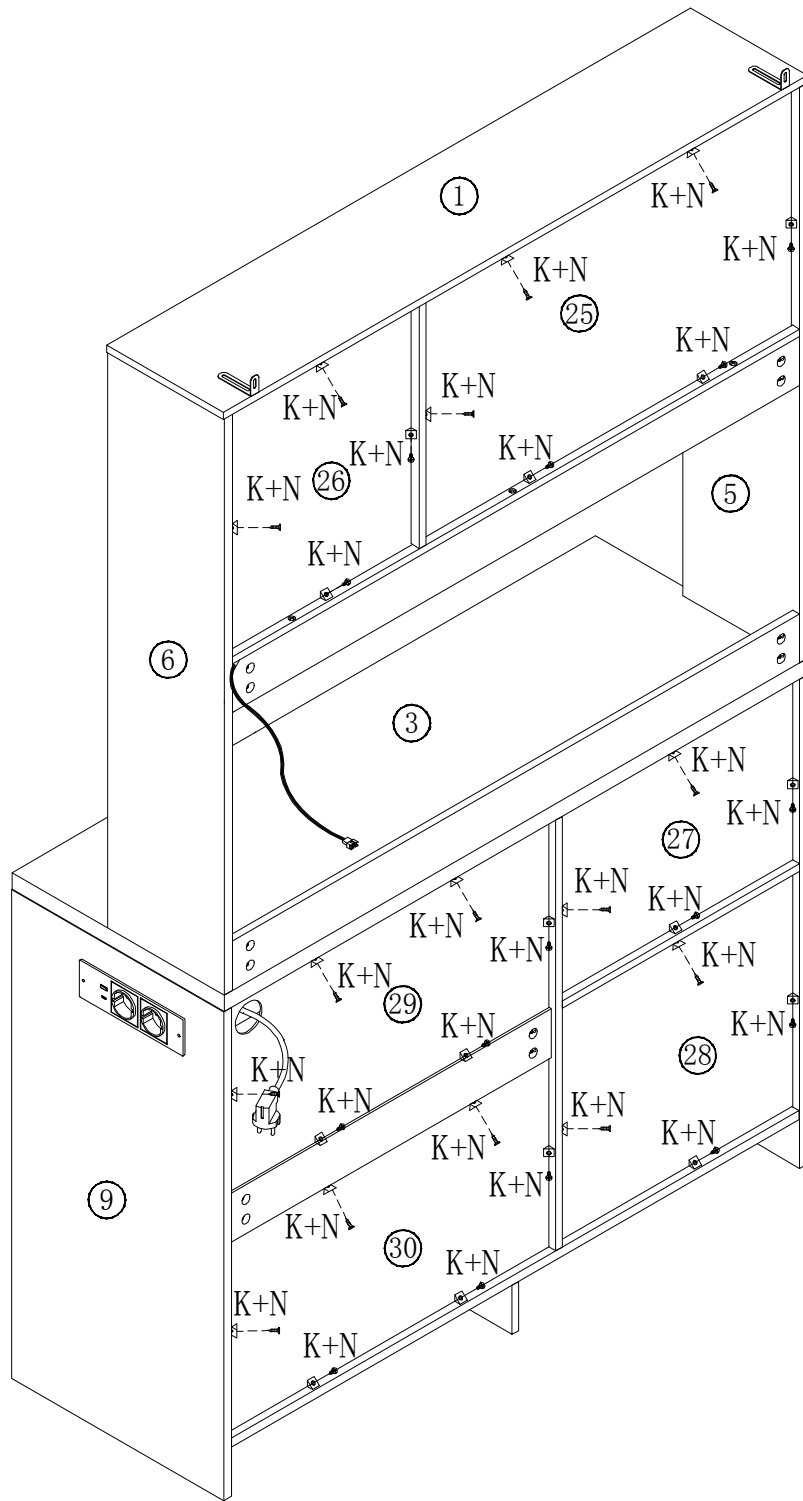

Step 28

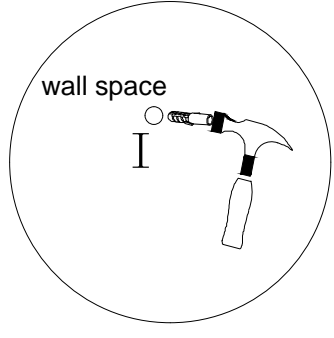
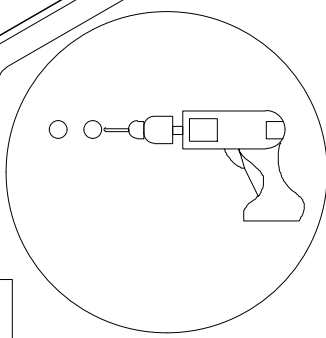
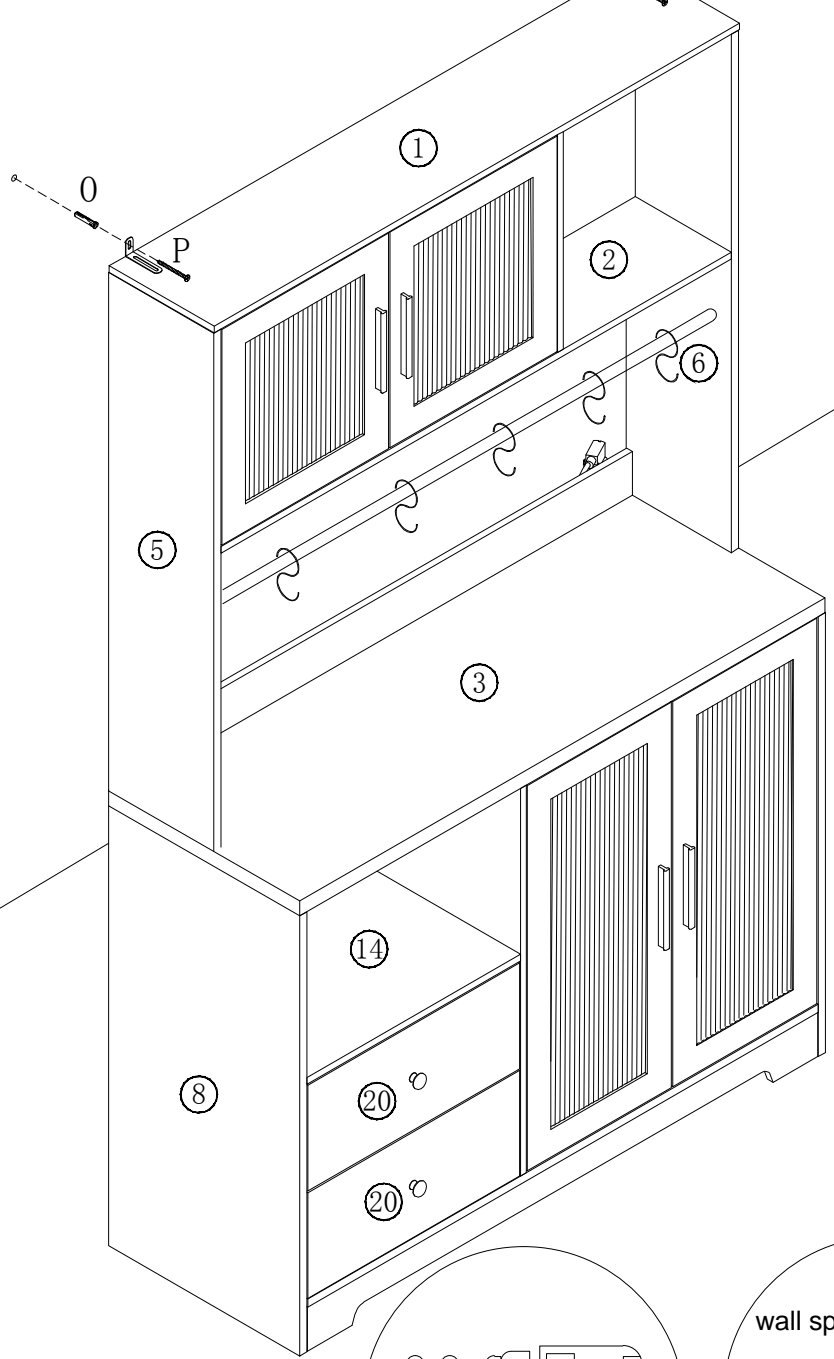
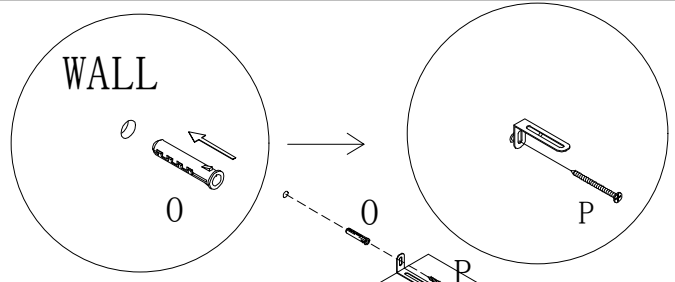

 Backboard clamp x30	 3*14 self-tapping x30
--	---

Step 29

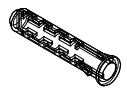

O 6*30 expansion bolt x 2		P 4*30 self-tapping x 2	
--	---	--------------------------------------	---

Step 30

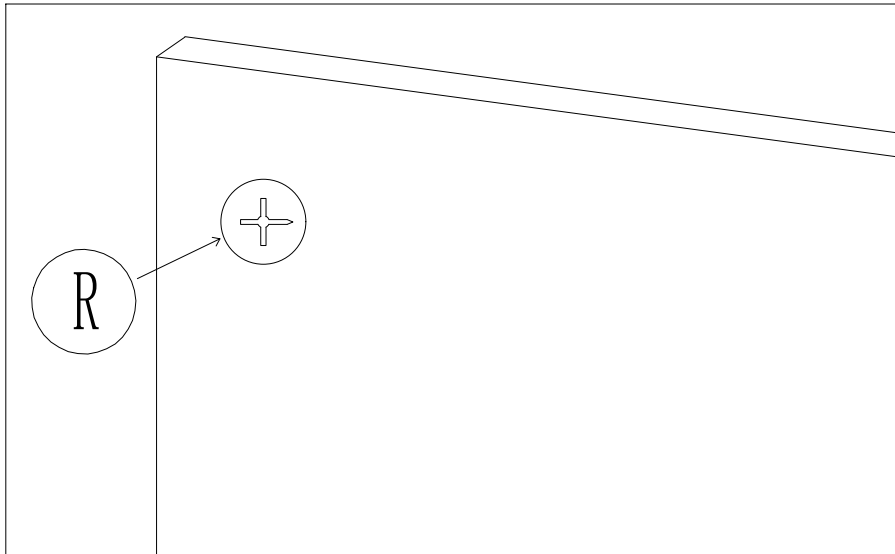

UK: After installing the product, stick the number R on the perforated position



FR: Une fois le produit installé, collez le numéro R à l'endroit où il y a des trous

DE: Nach der Installation des Produkts kleben Sie die Nummer R auf die perforierte Position

IT: Dopo l'installazione del prodotto, fissare il numero R sulla posizione perforata

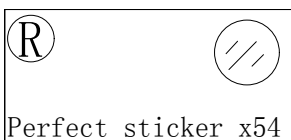
ES: Después de instalar el producto, pegue el número R en la posición perforada



Importeur	Decobus Handel GmbH
Adresse	Innungsstraße 9, 21244 Buchholz, Deutschland
URL	https://www.decobusgroup.de
Hersteller	DONGGUAN GUANGTAI ENTERPRISE CO. , LTD
Adresse	No. 2, Dapianmei District, DalingshanTown, Dongguan City, GuangdongProvince
URL/Email	a15626863151@163.com
Produktiondatum	2026/05
Hergestellt In	China
	Decobus Handel GmbH Innungsstraße 9, 21244 Buchholz, Deutschland https://www.decobusgroup.de
 	Product : Furniture Power Distribution Unit Modell : JN02-00-22 Input:220-250V~,50Hz 16A Max 3680W USB Output:5V= 2.1A 10.5W Max For Indoor Use Only

ATTESTATION

BESCHEINIGUNG

ATESTACIÓN

ATTESTATO

ATTESTATION

Attestation of Conformity

No. E8A 128892 0006 Rev. 00



Product Service

Holder of Attestation: GUANG TAI ENTERPRISE CO., LTD.

Rm 402, Bldg 4, No.2 Dapianmei Rd.
Dapianmei Village, Dalingshan
523000 Dongguan, Guangdong
PEOPLE'S REPUBLIC OF CHINA

Name of Object:

**Power supply
(Furniture Power Distribution Unit)**

Model(s):

JN00-00-02K, JN00-00-03K, JN00-00-04K, JN02-00-21,
JN02-00-22, JN02-00-23, JN02-00-23K, JN02-00-24K,
JN02-00-24, JN02-00-22M, JN02-00-23M, JN02-00-23KM

Description of Object:

Ratings:
Input: 220-250VAC, 50Hz, Max 16A, Max 3680W
USB A1/USB A2 Output: 5.0VDC, 2.1A, 10.5W Max
Total USB output: 5.0VDC, 2.1A, 10.5W Max
Protection Class: I

Tested according to:

EN 55032:2015/A1:2020
EN 55035:2017/A11:2020
EN IEC 61000-3-2:2019/A1:2021
EN 61000-3-3:2013/A2:2021

This Attestation of Conformity is issued on a voluntary basis according to the Directive 2014/30/EU relating to electromagnetic compatibility. It confirms that the listed apparatus complies with the principal protection requirements of the directive and is based on the technical specifications applicable at the time of issuance. It refers only to the particular sample submitted for conformity assessment. For details see: www.tuvsud.com/ps-cert

Test report no.: 657602423101

Date: 2025-01-10

(Laurent Yuan)

Page 1 of 1

This Attestation does not replace the regulatory EU Declaration of Conformity (DoC) and does not allow for CE marking. After preparation of the necessary documentation and establishing compliance to requirements of all applicable directives, the manufacturer may sign a DoC and apply the CE marking. The DoC is issued under the sole responsibility of the manufacturer.

TÜV SÜD Product Service GmbH • Rüdigerstraße 65 • 80339 Munich • Germany

TUV®



Certificate of Compliance

RoHS Directive 2011/65/EU appendix II Revised instructions (EU) 2015/863 of the European parliament and of the council on the restriction of the use of certain hazardous substances in electrical and electronic equipment

Issue Date: Nov.27, 2025

Company Name	: GUANG TAI ENTERPRISE CO.,LTD
Address	: Rm402,Bldg 4,No.2 Dapianmei Rd.Dapianmei Village,Dalingshang DONGGUAN GUANGDONG
Manufacturer	: GUANG TAI ENTERPRISE CO.,LTD
Address	: Rm402,Bldg 4,No.2 Dapianmei Rd.Dapianmei Village,Dalingshang DONGGUAN GUANGDONG
Sample Name	: Furniture Power Distribution Unit
Sample Model	: JN02-00-21;JN02-00-111;JN02-00-112;JN02-00-212; JN02-00-22;JN00-00-02K;JN02-00-113K;JN02-00-113; JN02-00-213;JN02-00-23;JN00-00-03K;JN00-00-03; JN00-00-04K;JN00-00-04; JN02-00-23K

This certificate of compliance is based on a test procedure or an evaluation of the above-mentioned product. This is to certify that the above-mentioned product is in compliance with the According to IEC63000:2018+AMD1:2017 and RoHS Directive 2011/65/EU Revised instructions (EU) 2015/863 of the European parliament.

It is only valid in connection with the test report (Report No.: COBO25110736-R1)

RoHS

Signed for and on Behalf of COBO

Sam Xie / Technical Manager

GUANGDONG TI COBO TESTING CO.,LTD.

EA601,Yishili Building No.9,Zongbu 2nd Road,Songshan Lake Sci.&Tech. Park,Dongguan,Guangdong,China

Tel:86-769-26622263

Fax:86-769-26622012





Product Service

Attestation of Conformity

No. N8A 128892 0001 Rev. 00

Holder of Attestation: **GUANG TAI ENTERPRISE CO., LTD.**

Rm 402, Bldg 4. No.2 Dapianmei Rd.
Dapianmei Village, Dalingshan
523000 Dongguan, Guangdong
PEOPLE'S REPUBLIC OF CHINA

Product: **Cord extension set
(Furniture Power Distribution Unit)**

This Attestation of Conformity is issued on a voluntary basis according to the Low Voltage Directive 2014/35/EU relating to electrical equipment designed for use within certain voltage limits. It confirms that the listed equipment complies with the principal protection requirements of the directive and is based on the technical specifications applicable at the time of issuance. It refers only to the particular sample submitted for conformity assessment. For details see: www.tuvsud.com/ps-cert

Test report no.: 6810024020501

Date, 2025-01-10

(Michael Xu)

Page 1 of 2

This Attestation does not replace the regulatory EU Declaration of Conformity (DoC) and does not allow for CE marking. After preparation of the necessary documentation and establishing compliance to requirements of all applicable directives, the manufacturer may sign a DoC and apply the CE marking. The DoC is issued under the sole responsibility of the manufacturer.



Product Service

Attestation of Conformity

No. N8A 128892 0001 Rev. 00

Model(s): **JN00-00-02K, JN00-00-03K, JN00-00-04K,
JN02-00-21, JN02-00-22, JN02-00-23,
JN02-00-23K, JN02-00-24K, JN02-00-24,
JN02-00-22M, JN02-00-23M, JN02-00-23KM**

Parameters:
220-250V~, 50Hz, Max. 16A, Max. 3680W
USB A1/USB A2 Output: 5.0VDC, 2.1A, 10.5W Max.
Total USB output: 5.0VDC, 2.1A, 10.5W Max

These models in addition to the naming and some models with connectors, no other difference.



Table 1 model difference:

Model	Difference
JN00-00-02K, JN00-00-03K, JN00-00-04K, JN02-00-21, JN02-00-22, JN02-00-23, JN02-00-23K, JN02-00-24K, JN02-00-24	Without AC connector:
JN02-00-22M, JN02-00-23M, JN02-00-23KM	With AC connector:

Tested according to: IEC 60884-1:2002
IEC 60884-1:2002/AMD1:2006
IEC 60884-1:2002/AMD2:2013
IEC 60884-2-7:2011
IEC 60884-2-7:2011/AMD1:2013
EN 62368-1:2014/A11:2017

Page 2 of 2

This Attestation does not replace the regulatory EU Declaration of Conformity (DoC) and does not allow for CE marking. After preparation of the necessary documentation and establishing compliance to requirements of all applicable directives, the manufacturer may sign a DoC and apply the CE marking. The DoC is issued under the sole responsibility of the manufacturer.

Importeur	Decobus Handel GmbH
Adresse	Innungsstraße 9, 21244 Buchholz, Deutschland
URL	https://www.decobusgroup.de
Hersteller	Shenzhen Pinchengxin Technology Co., Ltd
Adresse	3rd floor, 8 building Yuanling industrial zone, No. 39 Yuanlingcunroad, Shiyuan street, Bao'an district, Shenzhen
URL/Email	info@aitek.org.cn
Productiondatum	2026/05
Hergestellt In	China
	Decobus Handel GmbH Innungsstraße 9, 21244 Buchholz, Deutschland https://www.decobusgroup.de
	Product : 5050 RGB 5M light strip Modell : 5050-60D-RGB-10MM-5V Nennspannung : 5V Nennfrequenz : 50-60HZ Leistung : 2A

CERTIFICATE OF COMPLIANCE

No.: AITSZ-250710061C-C01

Product: 5050 RGB LED Strip Lights with Bluetooth App Controller
Trade Mark: N/A
Model: LED 5050 RGB
Applicant: Shenzhen Pinchengxin Technology Co., Ltd
Address: 3rd floor, 8 building Yuanling industrial zone, No. 39 Yuanlingcun road, Shiyuan street, Bao'an district, Shenzhen
Manufacture: Shenzhen Pinchengxin Technology Co., Ltd
Address: 3rd floor, 8 building Yuanling industrial zone, No. 39 Yuanlingcun road, Shiyuan street, Bao'an district, Shenzhen

The test sample of product has passed the test according to requirements of the following standards:

Standard(s):	Test report(s) No.:
EN 55032:2015+A11:2020	AITSZ-250710061CE1
EN 55035:2017+A11:2020	

Based on the voluntary assessment of the product sample and technical file, we confirm that the above-mentioned product meets the essential requirements of the Electromagnetic Compatibility (EMC) Directive 2014/30/EU.

The CE mark as shown below can be used, under the responsibility of the manufacturer or the importer, after completion of an EC declaration of conformity and follow the CE mark usage rules.



Approved by/Date:

Allen Wang
Allen Wang



The statement is based on a single evaluation of one sample of above mentioned products. It does not imply an assessment of the whole production and does not permit the use of the test lab's logo.

Guangdong Asia Hongke Test Technology Limited



B1/F, Building 11, Junfeng Industrial Park, Chongqing Road, Heping Community, Fuhai Street, Bao'an District, Shenzhen, Guangdong, China
www.aitek.org.cn
 E-mail: info@aitek.org.cn

CERTIFICATE OF COMPLIANCE

No.: AITSZ-250710061C-C02

Product: 5050 RGB LED Strip Lights with Bluetooth App Controller
Trade Mark: N/A
Model: LED 5050 RGB
Applicant: Shenzhen Pinchengxin Technology Co., Ltd
Address: 3rd floor, 8 building Yuanling Industrial zone, No. 39 Yuanlingcun road, Shiyuan street, Bao'an district, Shenzhen
Manufacturer: Shenzhen Pinchengxin Technology Co., Ltd
Address: 3rd floor, 8 building Yuanling Industrial zone, No. 39 Yuanlingcun road, Shiyuan street, Bao'an district, Shenzhen

The test sample of product has passed the test according to requirements of the following standards:

Standard(s):	Test report(s) No.:
Article 3.1a)	EN 60598-2-4:2018 used in conjunction with EN IEC 60598-1:2021+A11:2022 EN 62479: 2010 EN 50663: 2017 AITSZ-250710061S AITSZ-250710061CW3
Article 3.1b)	ETSI EN 301 489-1 V2.2.3 (2019-11) ETSI EN 301 489-17 V3.2.4 (2020-09) AITSZ-250710061CW1
Article 3.2)	ETSI EN 300 328 V2.2.2 (2019-07) AITSZ-250710061CW2

Based on the voluntary assessment of the product sample and technical file, we confirm that the above-mentioned product meets the essential requirements of the Radio Equipment Directive (RED) 2014/53/EU.

The CE mark as shown below can be used, under the responsibility of the manufacturer or the importer, after completion of an EC declaration of conformity and follow the CE mark usage rules.



Approved by/Date:

Sean She
Sean She
Aug 07 2025



The statement is based on a single evaluation of one sample of above mentioned products. It does not imply an assessment of the whole production and does not permit the use of the test lab's logo.



Guangdong Asia Hongke Test Technology Limited
B1/F, Building 11, Junfeng Industrial Park, Chongqing Road, Heping Community, Futai Street, Bao'an District, Shenzhen, Guangdong, China
www.aitek.org.cn
E-mail: info@aitek.org.cn

Certificate of Compliance

Certificate No.: AITSZ-250710061RC09

The EUT described above has been consolidated by us and found in compliance with the council RoHS 2.0 Directive(EU)2015/863and(EU)2017/12102 amending Annex I to Directive2011/65/EU.

Applicant : Shenzhen Pinchengxin Technology Co., Ltd
Address : 3rd floor, 8 building Yuanling Industrial zone, No. 39 Yuanlingcun road, Shiyuan street, Bao'an district, Shenzhen
Manufacturer : Shenzhen Pinchengxin Technology Co., Ltd
Address : 3rd floor, 8 building Yuanling Industrial zone, No. 39 Yuanlingcun road, Shiyuan street, Bao'an district, Shenzhen
Product : 5050 RGB LED Strip Lights with Bluetooth App Controller
Model No. : LED 5050 RGB
Trade mark : N/A
Test Report No. : AITSZ-250710061R

Test Standards:
IEC 62321-3-1: 2013
IEC 62321-4:2013+AMD1:2017 GSV
IEC 62321-5:2013
IEC 62321-6:2015
IEC 62321-7:1:2015
IEC 62321-7-2:2017
IEC 62321-8:2017

ROHS

Lizhen
Lizhen
Date: Jul 18, 2025



The statement is based on a single evaluation of one sample of above mentioned products. It does not imply an assessment of the whole production and does not permit the use of the test lab logo.



Guangdong Asia Hongke Test Technology Co., Ltd.
B1/F, Building 11, Junfeng Industrial Park, Chongqing Road, Heping Community, Futai Street, Bao'an District, Shenzhen, Guangdong, China
Tel: +86 0755-23096763
<https://www.aitek.org.cn>
E-mail: info@aitek.org.cn



TEST REPORT	
ErP verification of Ecodesign requirement for Exemption product Implementation measure (EU) 2019/2020 and (EU) 2019/2015	
Report Number	ZTLJ2501255
Tested by (+ signature)	Mo Xin Yi / Tester <i>Mo xinyi</i>
Reviewed by (+ signature)	Zheng Liang i/ Project handler <i>zheng liang</i>
Approved by (+ signature)	Zheng Liang / Technical Director <i>zheng liang</i>
Date of issue	July 16, 2025
Total number of pages	14pages
Testing laboratory	ZHIYUAN TESTING (SHENZHEN) CO., LTD
Address	5th Floor, R&D Center Building, Hongfa Jieteli High-tech Park, Shiyan Street, Baoan District, Shenzhen
Applicant's name	Shenzhen Pinchengxin Technology Co., Ltd.
Address	3rd floor, 8 building Yuanling industrial zon, No. 39 Yuanlingcun road, Shiyan street, Bao'an district, Shenzhen City, Guangdong Province, CHINA
Test specification:	
Standard	(EU) 2019/2020:2019-10-01 with Corrigendum; : (EU) 2019/2015:2019-03-11; (EU) 2021/341:2021-02-23; (EU) 2021/340:2020-12-17
Test procedure	ErP verification test
Non-standard test method.:	N/A
This test report is specially limited to the above client company and product model only. It may not be duplicated without prior written consent of ZTL Test.	
Manufacturer	Shenzhen Pinchengxin Technology Co., Ltd.
Address	3rd floor, 8 building Yuanling industrial zon, No. 39 Yuanlingcun road, Shiyan street, Bao'an district, Shenzhen City, Guangdong Province, CHINA
Factory	Shenzhen Pinchengxin Technology Co., Ltd.
Address	3rd floor, 8 building Yuanling industrial zon, No. 39 Yuanlingcun road, Shiyan street, Bao'an district, Shenzhen City, Guangdong Province, CHINA
Test item description	5050 RGB LED Strip Lights
Model name	5050 RGB LED
Trade Mark	N/A
Ratings	See model list

