

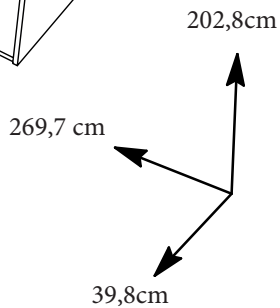

ENVIRONNEMENT DE LIT

3123ENVI

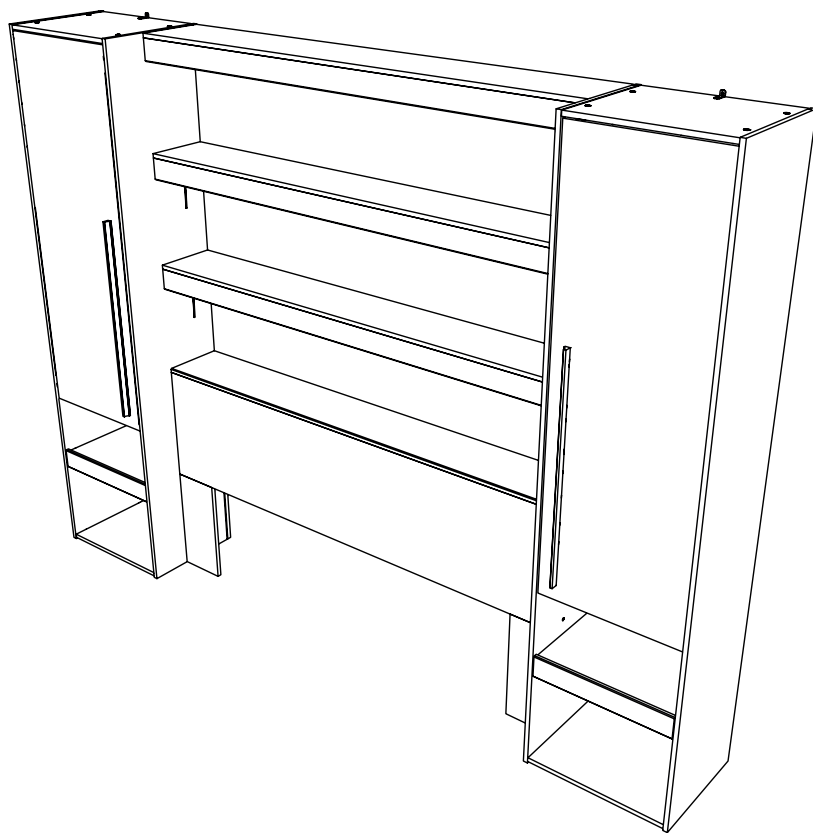

FR Remerciements :

Nous vous remercions d'avoir choisi un meuble créé et fabriqué par le Groupe Parisot et espérons qu'il vous donnera entière satisfaction.

EN Thanks:

Thank you for choosing furniture designed and manufactured by the Parisot Group.
We hope you are totally satisfied with your purchase.

DE Danksagung:

Wir danken Ihnen für den Kauf eines Frankreich von der Parisot-Gruppe entworfenen und hergestellten Möbelstücks und hoffen, dass Sie es zu Ihrer vollkommenen Zufriedenheit finden werden.

HU Köszönet:

Köszönjük, hogy a Parisot Groupe által létrehozott és gyártott bútort választott, reméljük, hogy elégedett lesz a termékkel.

PT Agradecimentos:

Obrigado por ter escolhido um móvel concebido e fabricado pelo Grupo Parisot, esperando que seja do seu inteiro agrado.

IT Ringraziamenti:

Grazie per avere scelto un mobile progettato e fabbricato dal Gruppo Parisot. Speriamo soddisfi appieno le vostre esigenze.

NL Bedankje:

Wij bedanken u voor de aankoop van een door de Groep Parisot ontworpen en vervaardigd meubel en hopen dat u er veel plezier aan zult beleven.

CZ Poděkování:

Děkujeme, že jste si vybrali nábytek navržený a vyrobený společností Parisot Group. Doufáme, že budete svým nákupem naprosto spokojeni.

ES Agradecimientos:

Les damos las gracias por haber elegido un mueble diseñado y fabricado por el Groupe Parisot y esperamos que sea de su total agrado.

PL Podziękowania:

Dziękujemy za wybór mebli stworzonych i wyprodukowanych przez Grupę Parisot. Mamy nadzieję, że będziecie Państwo w pełni zadowoleni z zakupu.

SK Pod'akovanie:

Ďakujeme, že ste si vybrali nábytok navrhnutý a vyrobený spoločnosťou Parisot Group. Dúfame, že budete svojim nákupom absolútne spokojní.

AR تشكر:

نشكركم لاختياركم هذه القطعة من الأثاث من تصميم وتصنيع مجموعة باريسو Parisot ونتمنى أن تنال رضائكم.



3h

PARISOT INDUSTRIE

15 Avenue Jacques Parisot, 70800 Saint-Loup sur Semouse
RCS VESOUL 537 665 200 contact@parisot.com

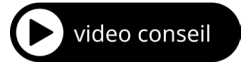

<https://qrco.de/bcJeNz>

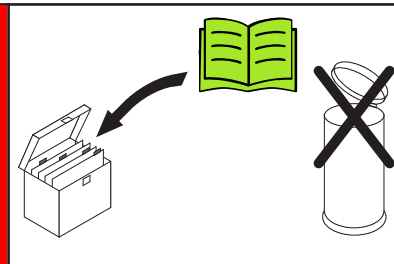
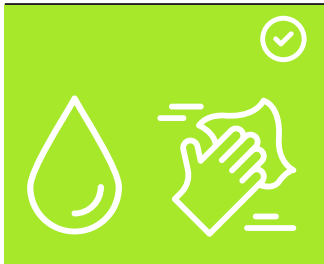
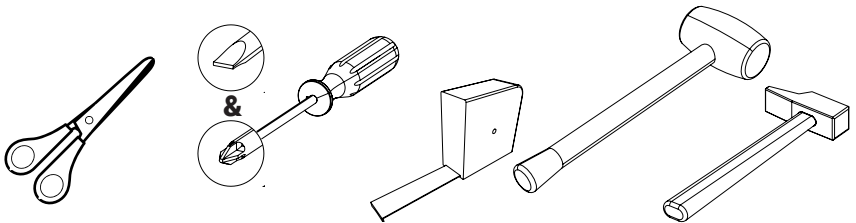

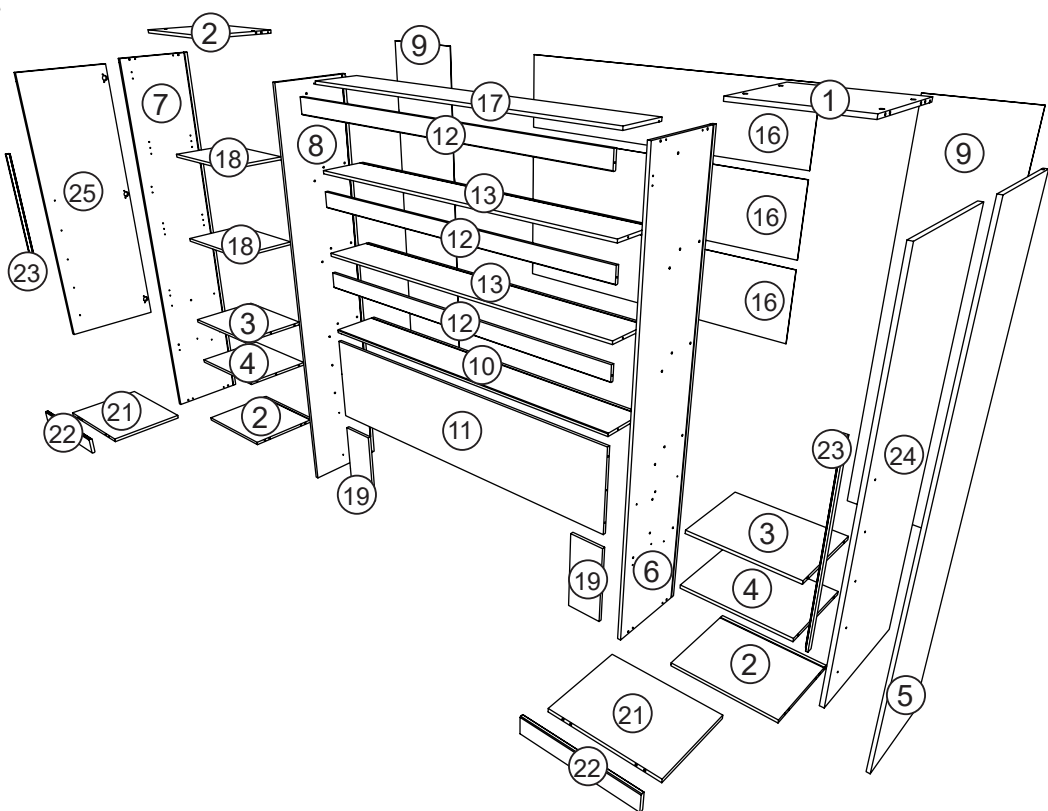

Rep	Qté	cm		
		Long.	Larg.	Ep.
01	1	47,1	39,6	1,5
02	3	47,1	39,6	1,5
03	2	47,1	36,1	1,5
04	2	47,1	36,1	1,5
05	1	202,8	39,8	1,5
06	1	202,8	39,8	1,5
07	1	202,8	39,8	1,5
08	1	202,8	39,8	1,5
09	2	200,8	48,3	0,25
10	1	169,5	24	1,5
11	1	169,5	42,3	1,5

Rep	Qté	cm		
		Long.	Larg.	Ep.
12	3	169,5	7,6	1,5
13	2	169,5	24	1,5
16	3	170,4	39,2	0,25
17	1	169,5	24	1,5
18	2	47,1	32,9	1,5
19	2	39,1	17,4	1,5
21	2	44,5	35,2	1,5
22	2	46,5	7,6	1,5
23	2	73,6	2,2	1,6
24	1	137,9	46,6	1,5
25	1	137,9	46,6	1,5

0 1cm 2 3 4 5

		x8
		x40
		x8
		x8
		x10
		x8
		x10
		x32
		x24

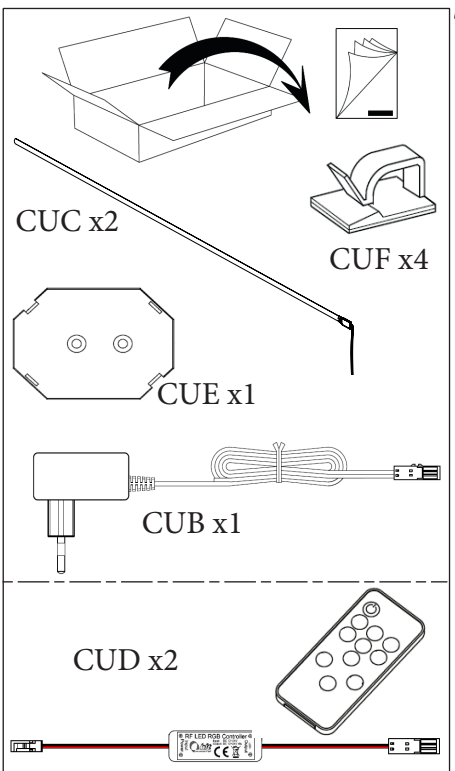

	x4
	x1
	x2
	x2
	x2
	x2
	x2
	x6
	x6
	x2
	x22
	x2
	x8
	x1
	x10
	x8
	x32
	x32

1



ADM

CTE

x4



x1



VE

x4

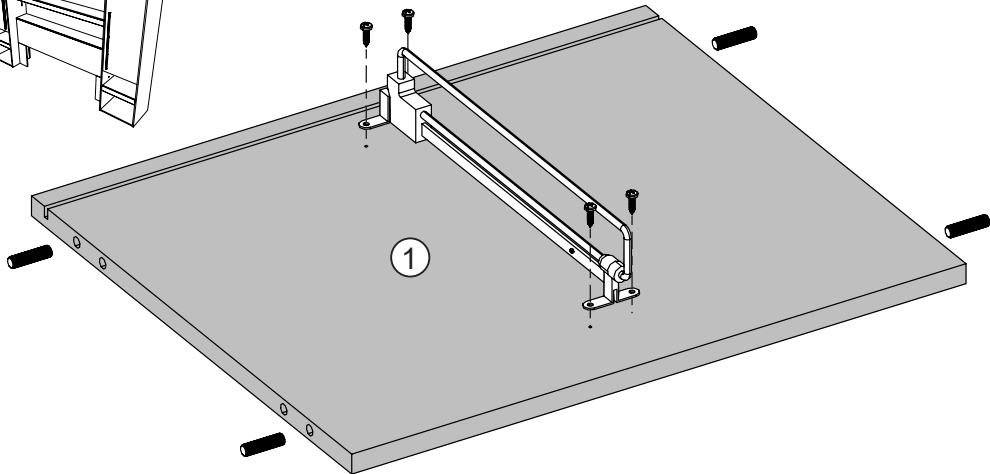
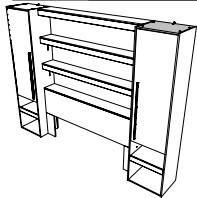

2



ADM

BQS

x8



x8

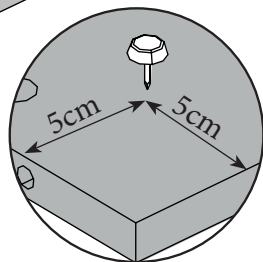
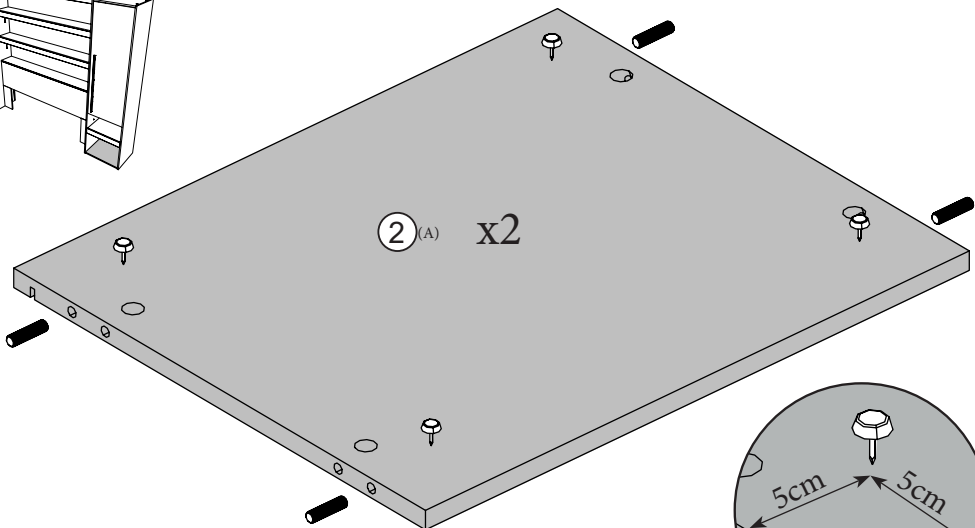
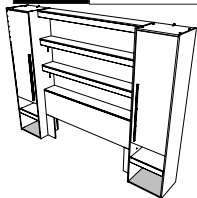

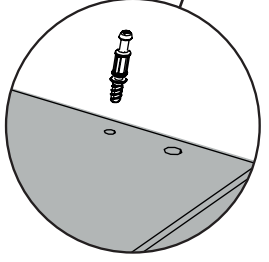
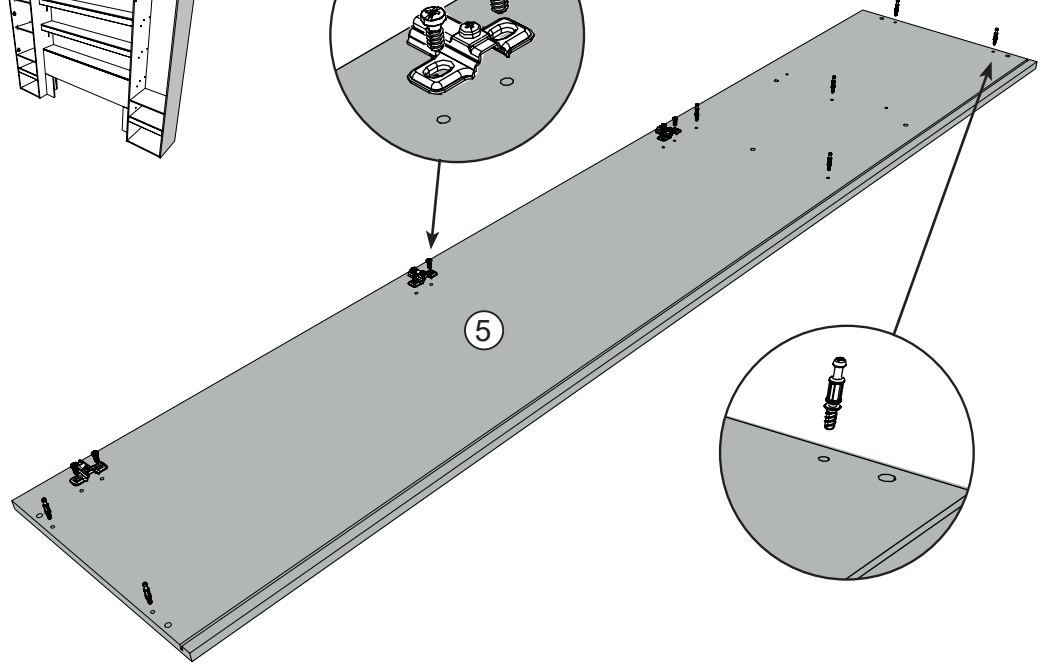
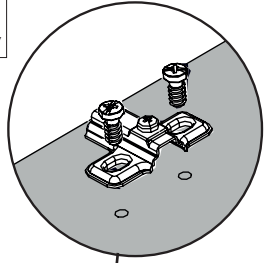
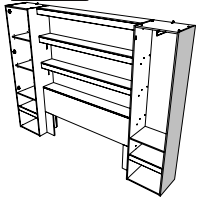
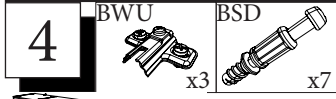
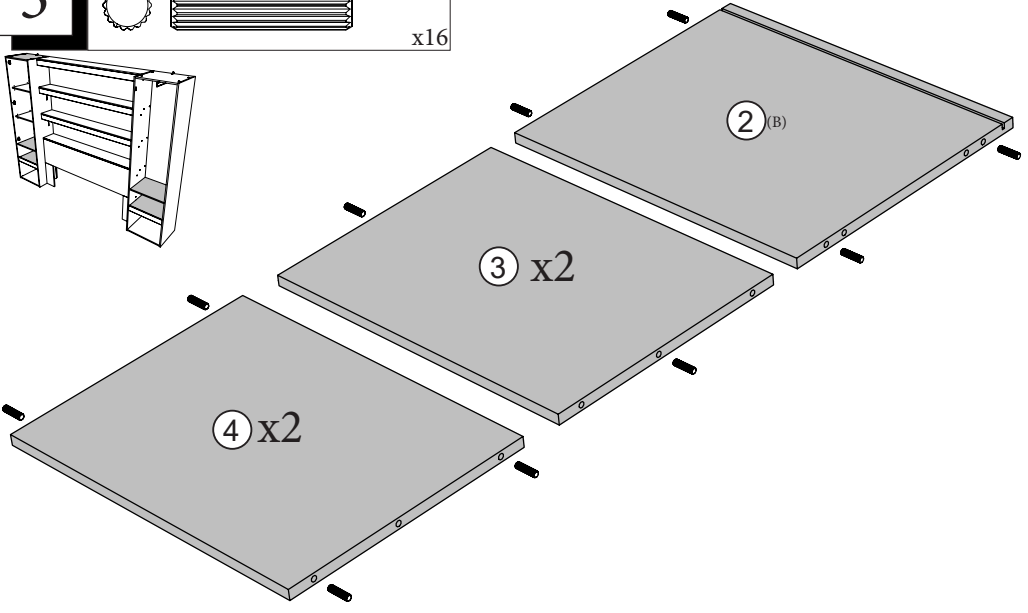
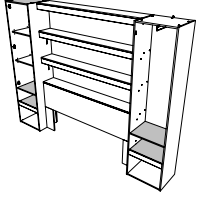
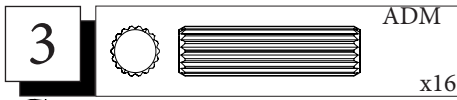

5

AFH x1

1.3cm
VG
x1

1.2cm
BWF
x2

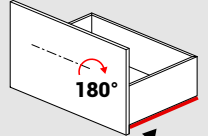
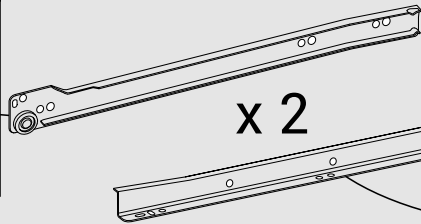
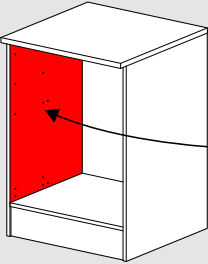
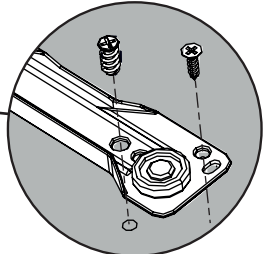
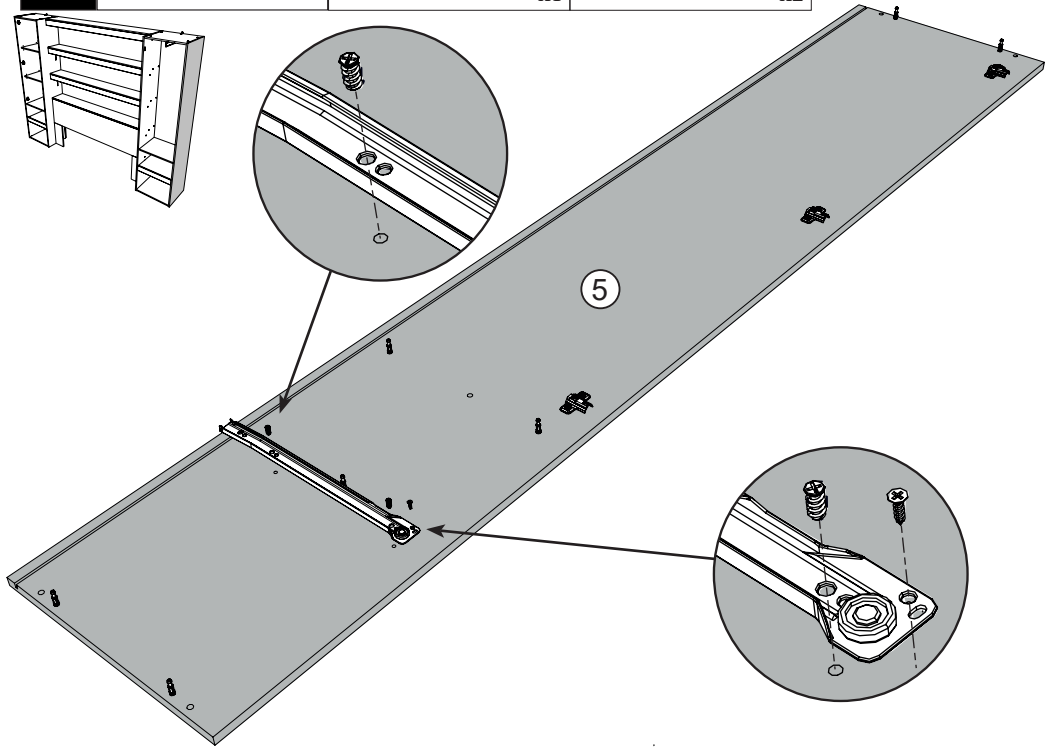
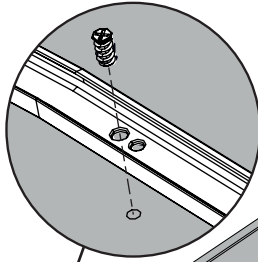
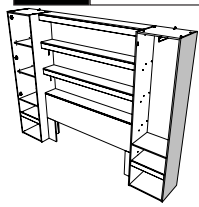

1 & 2 = BWF
3 = VG

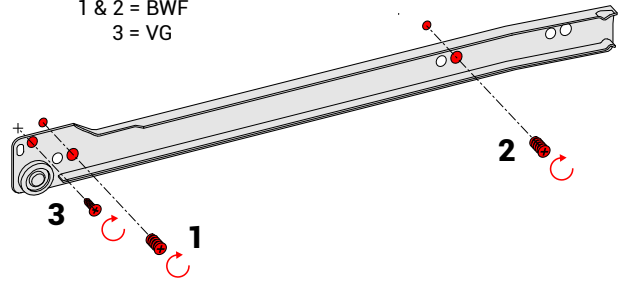

6



AFG x1

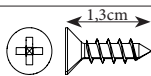

VG

x1

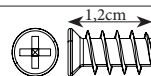

BWFBSD

x2

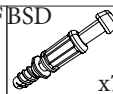

NZ

x1

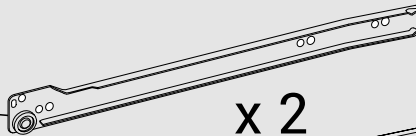
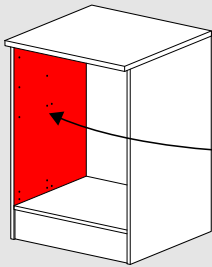
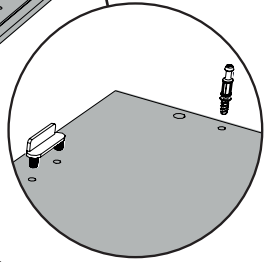
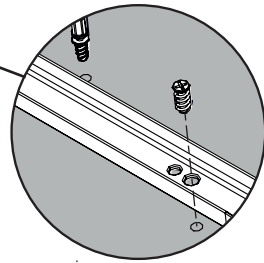
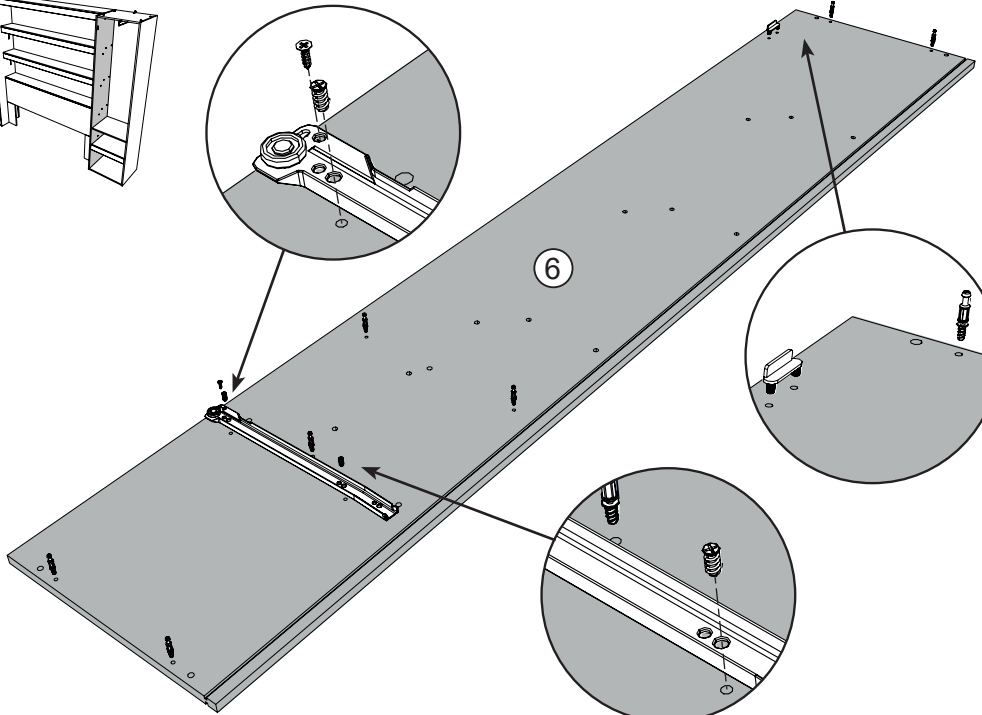
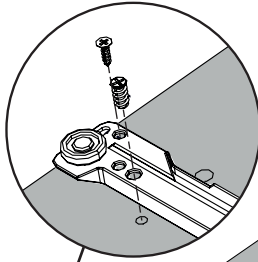
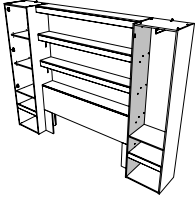

x 2

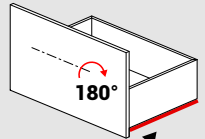
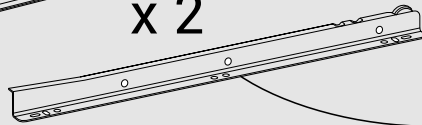

180°



1 & 2 = BWF
3 = VG

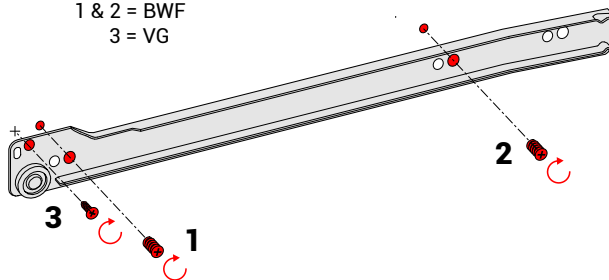

7 A1 x7

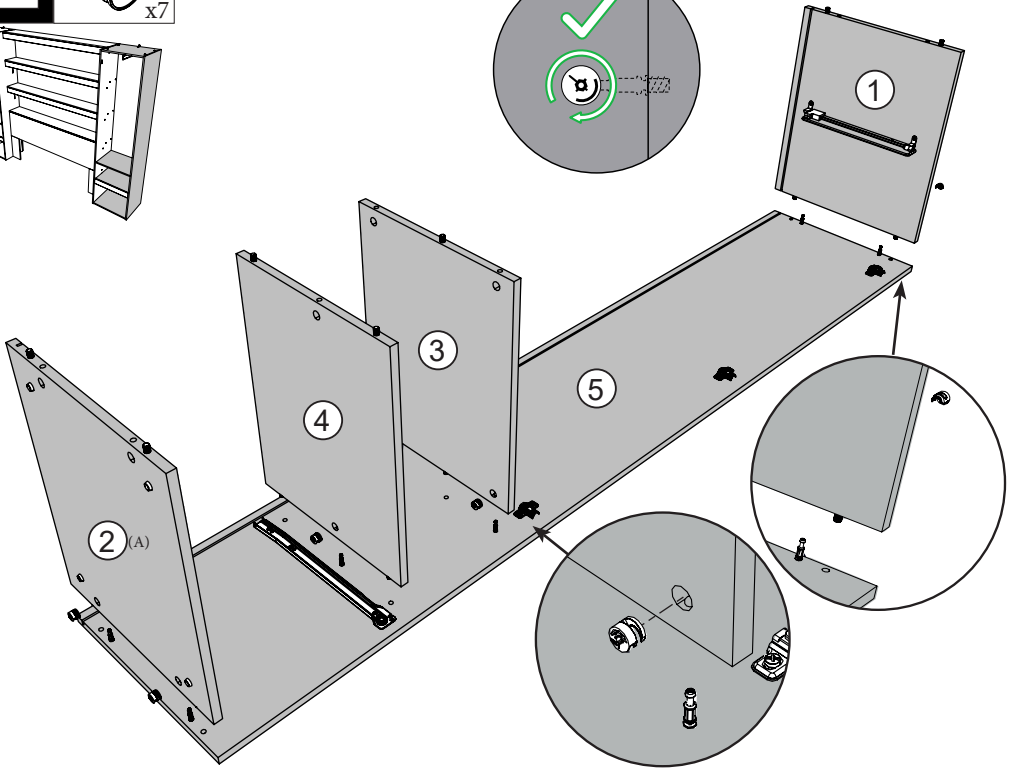
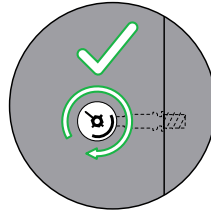
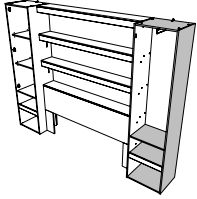

8

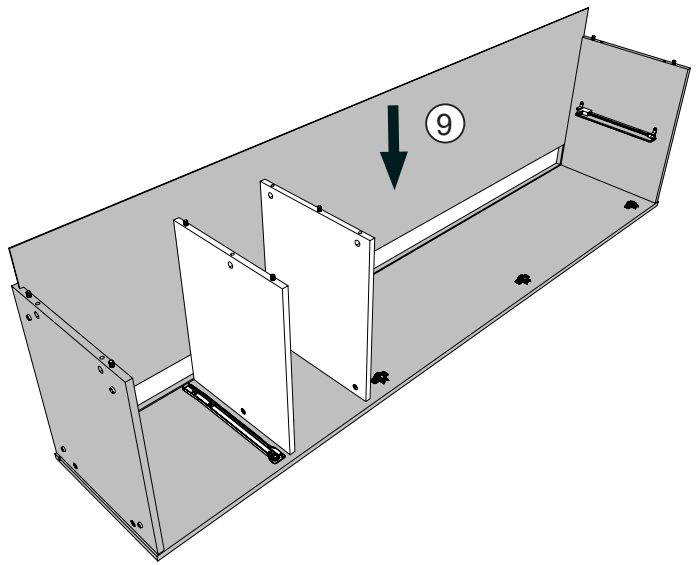
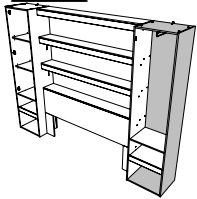

9 AI x7

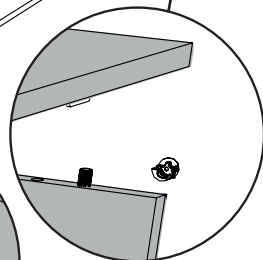
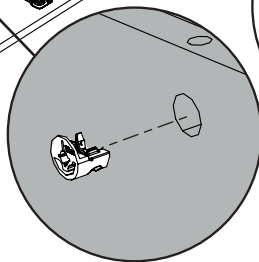
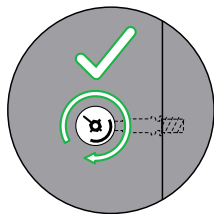
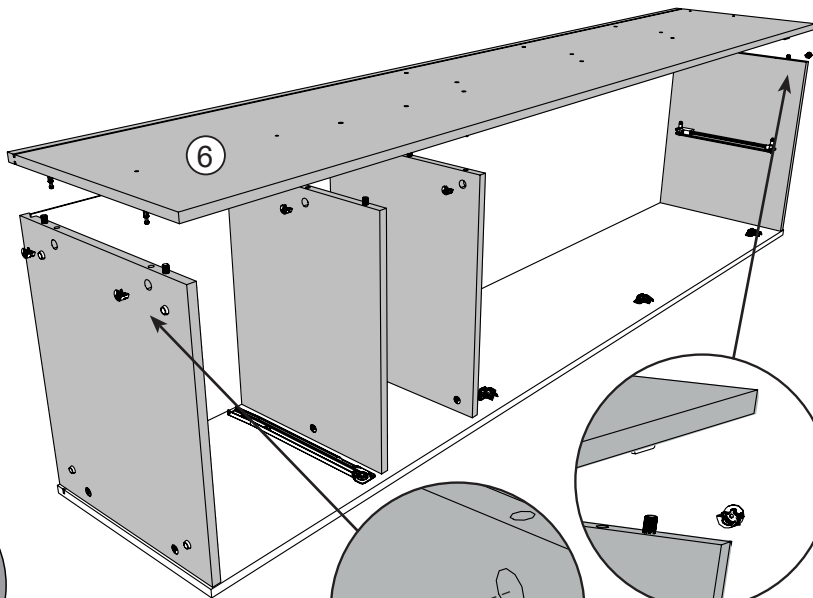
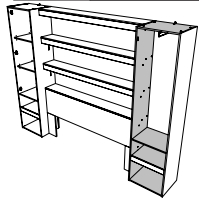

10 BWU x3 BSD x7

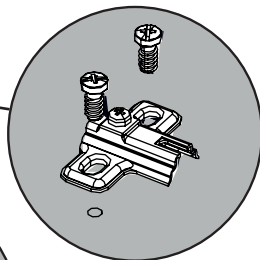
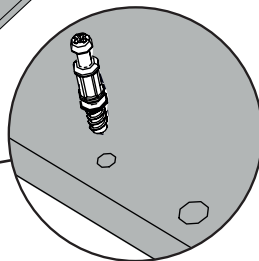
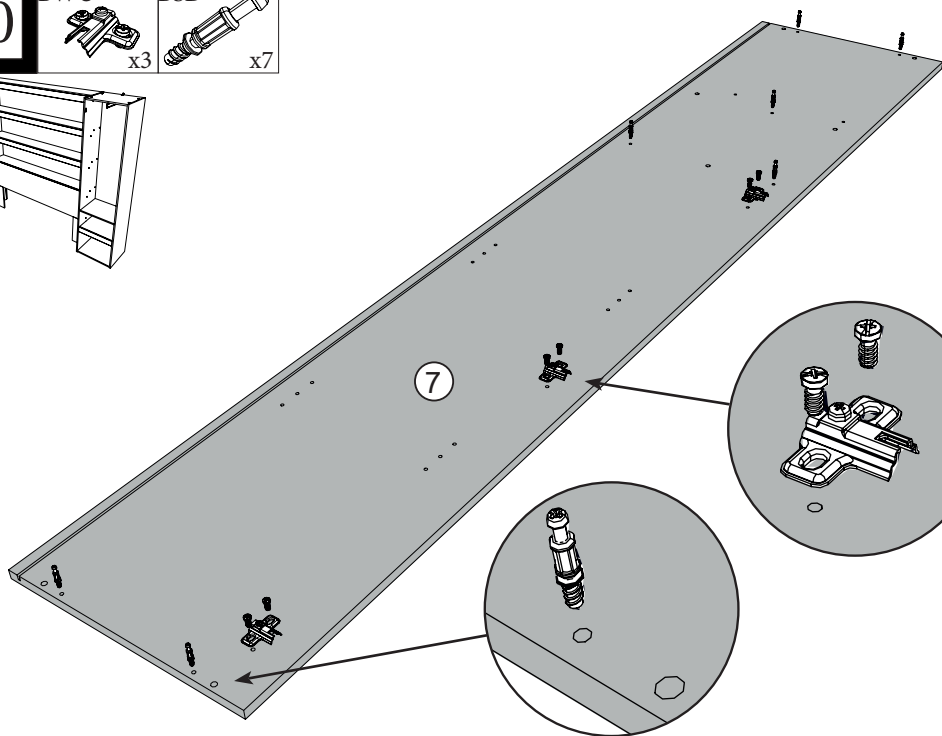
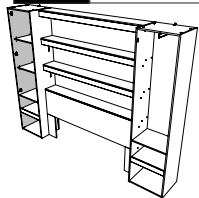

11

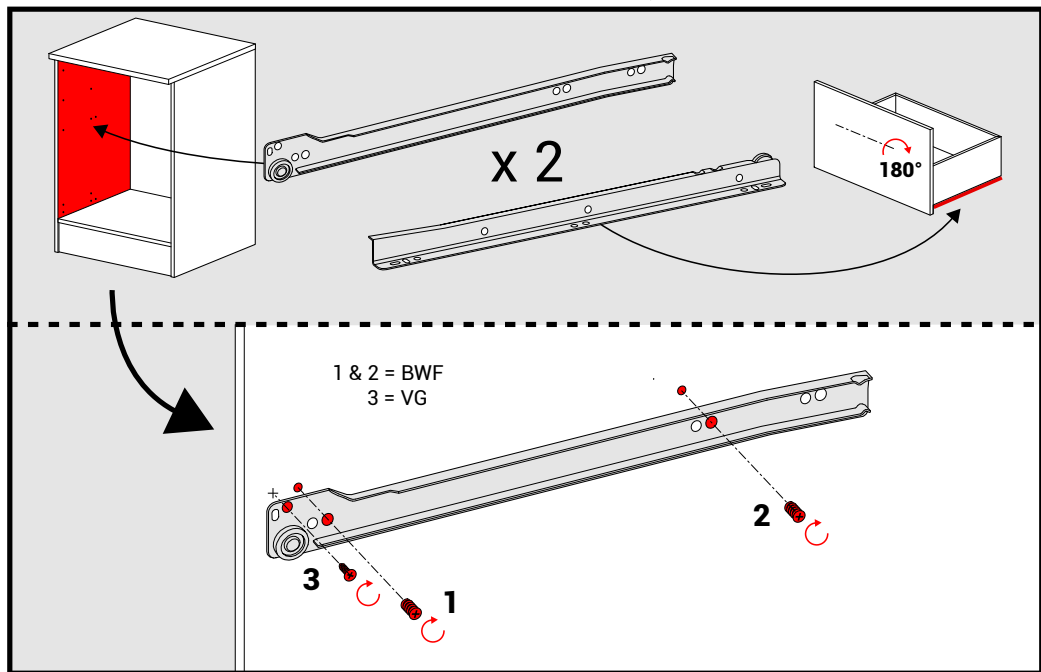
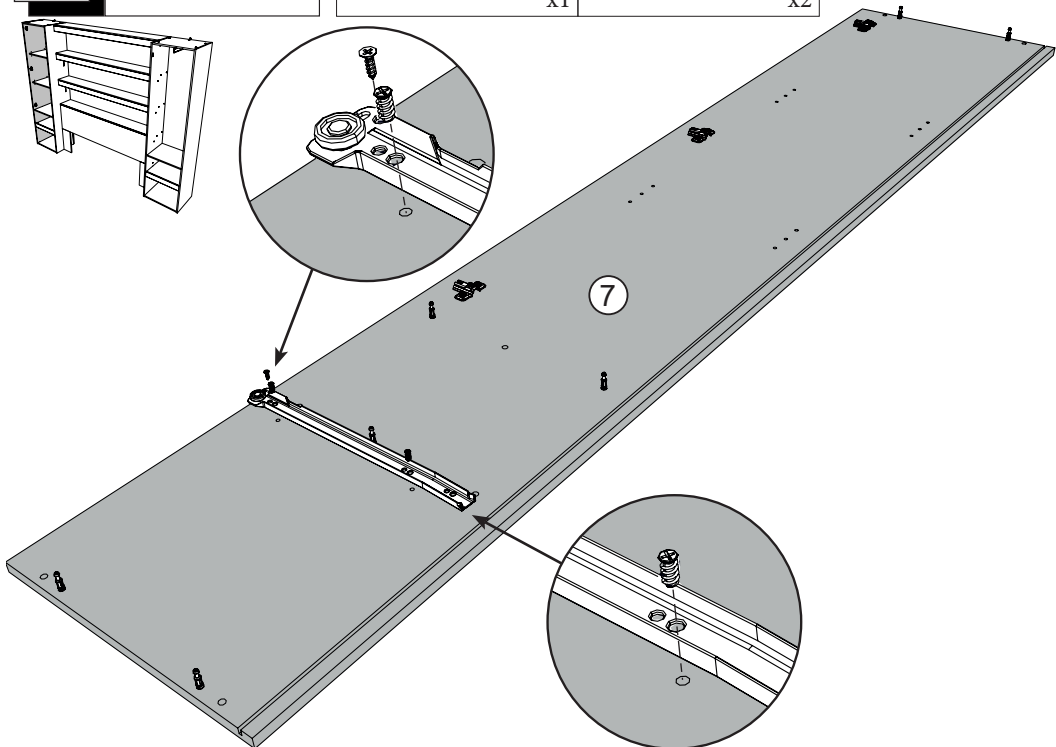
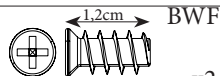
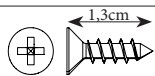
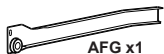

12

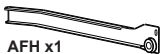

AFH x1

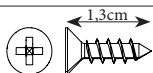

VG

x1

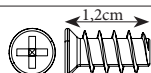

BWFBSD

x2

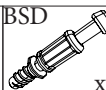

NZ

x1

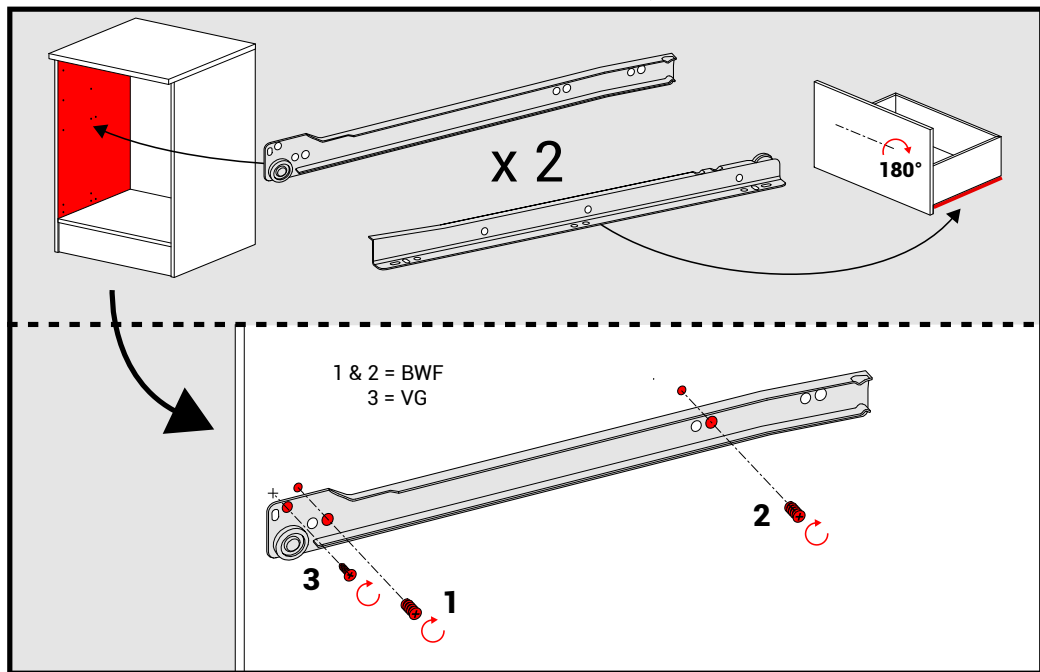
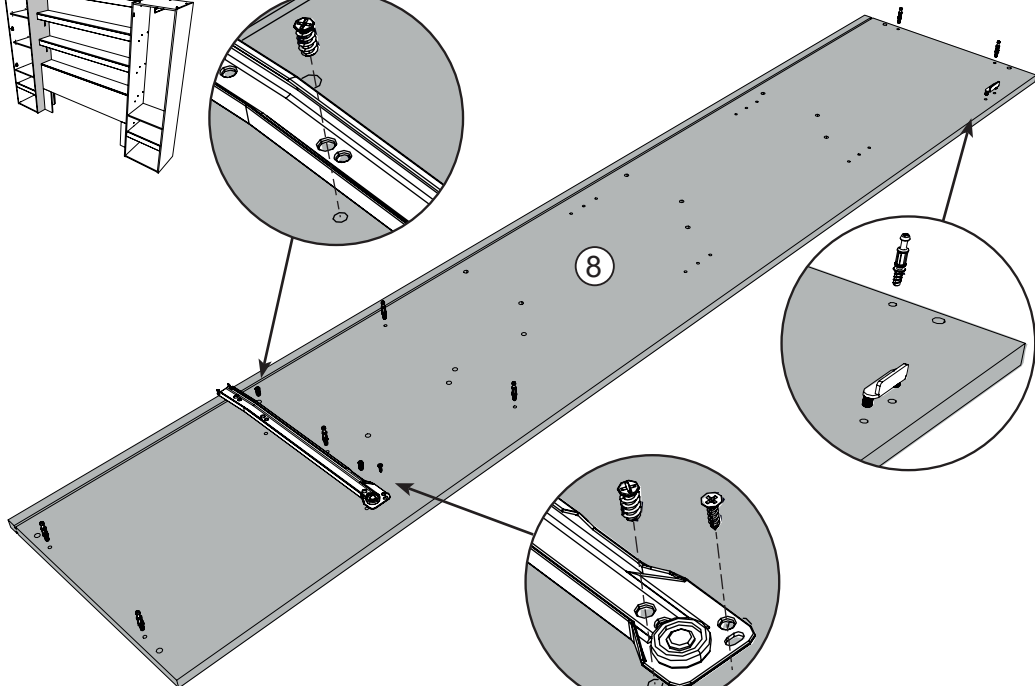
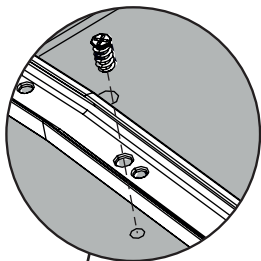
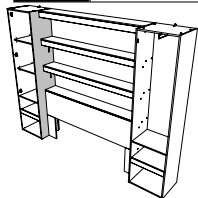

13

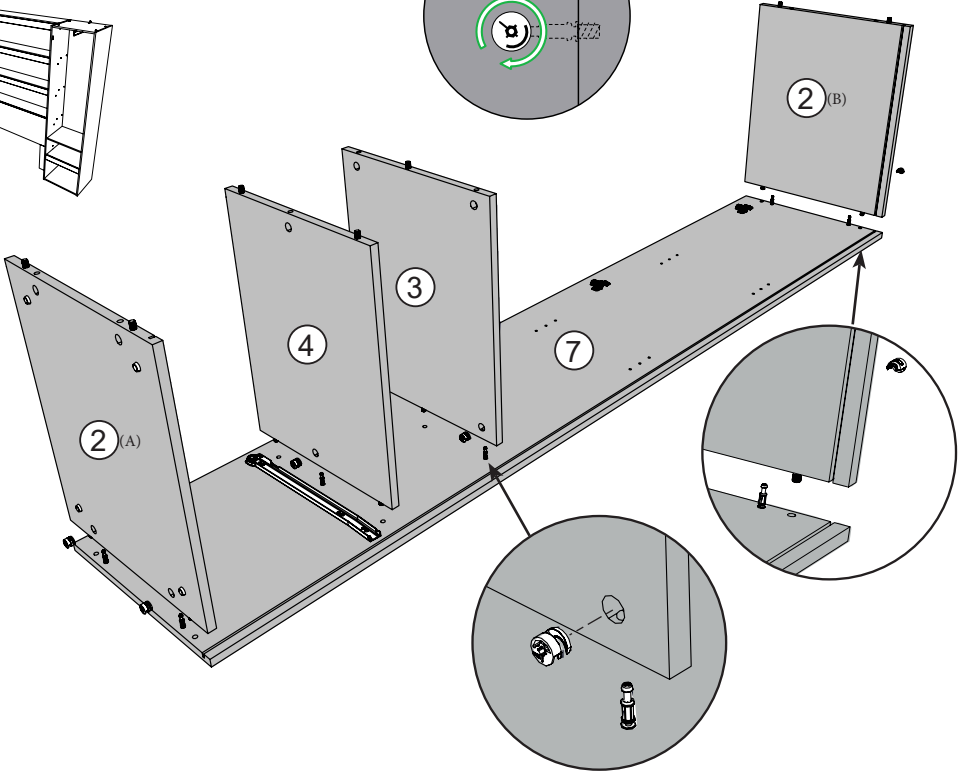
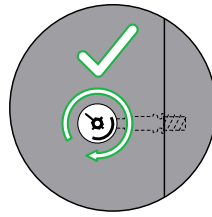
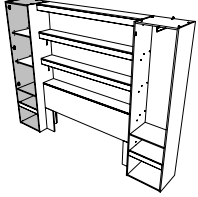
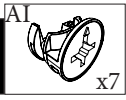

14

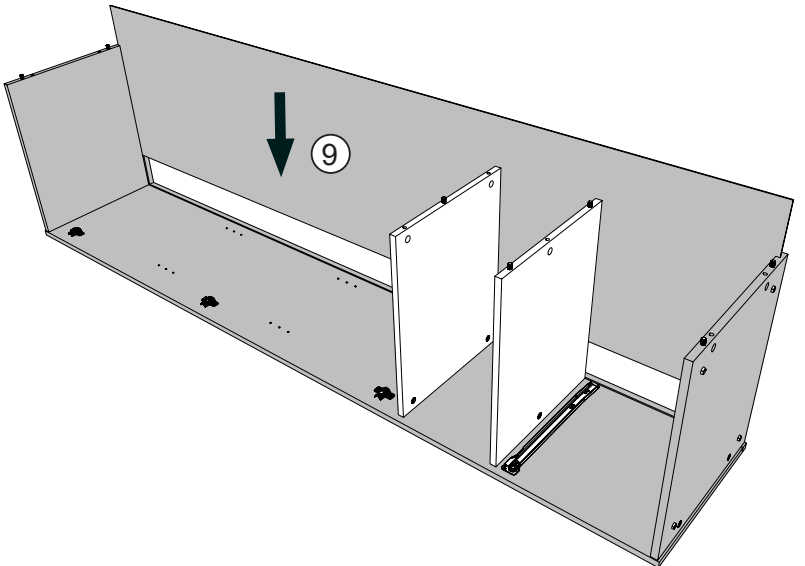
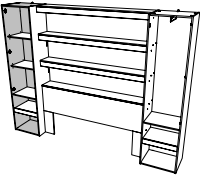

15 AI



x7

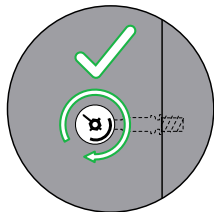
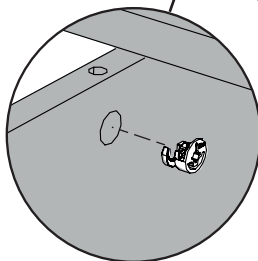
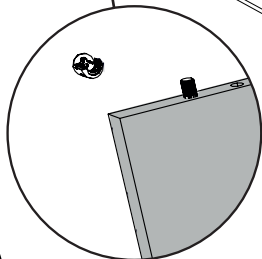
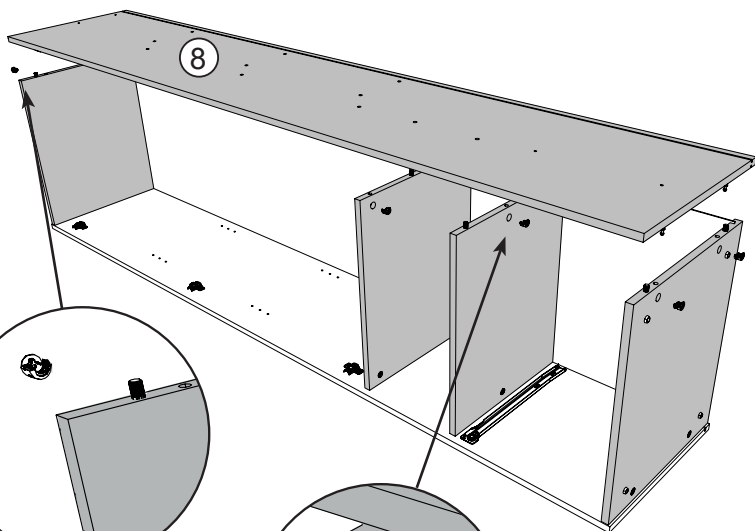
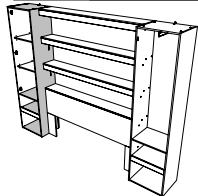

16

BLL



x4



VB



x8

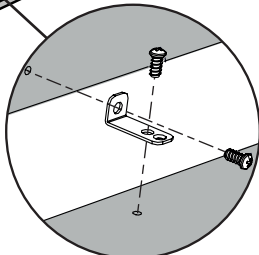
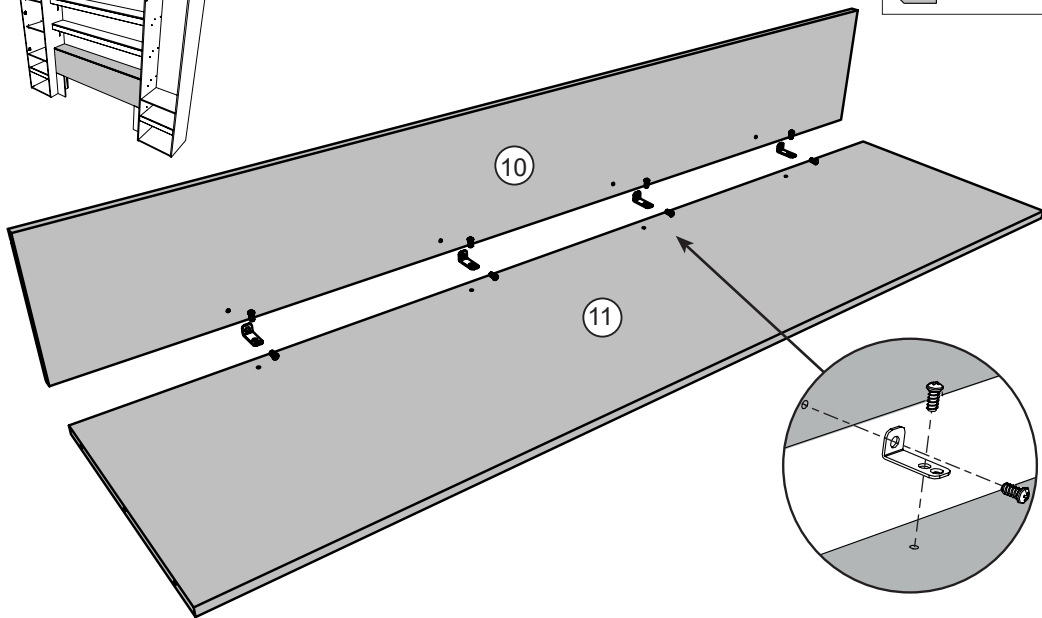
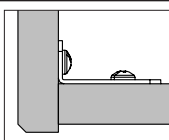
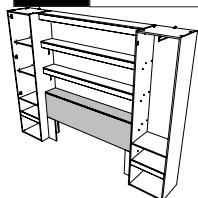

17

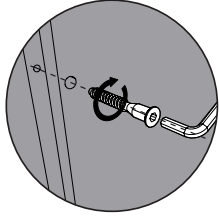
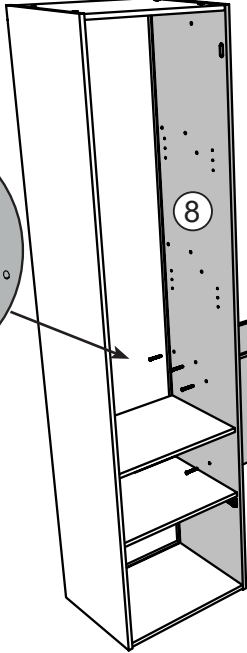
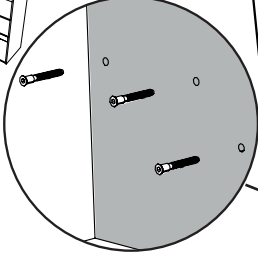
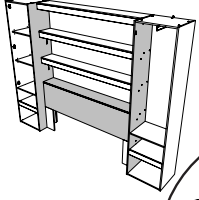
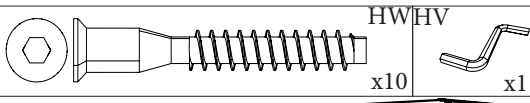

18

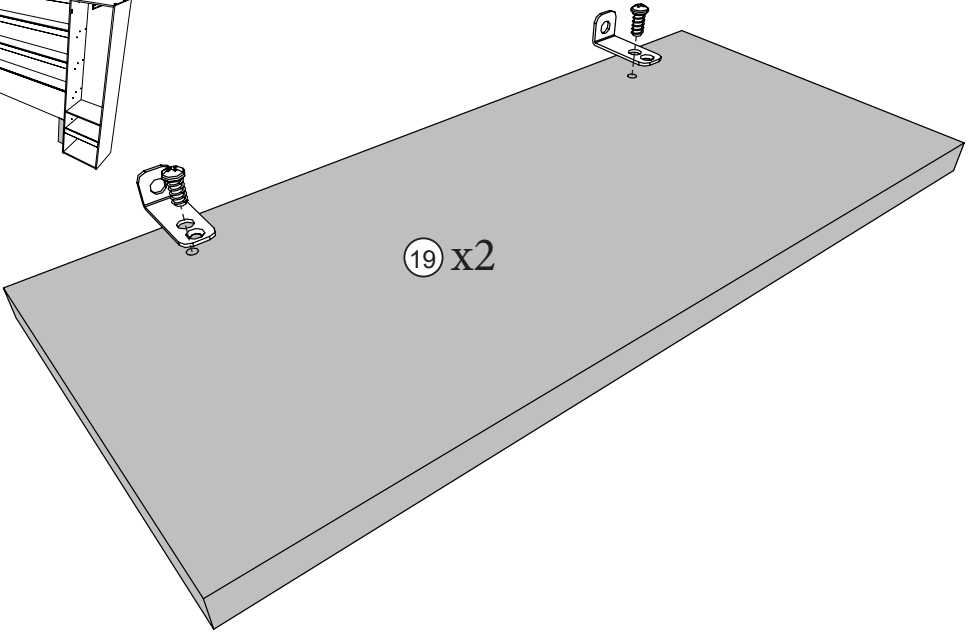
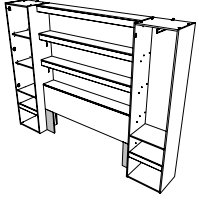
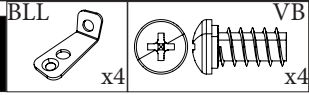

19

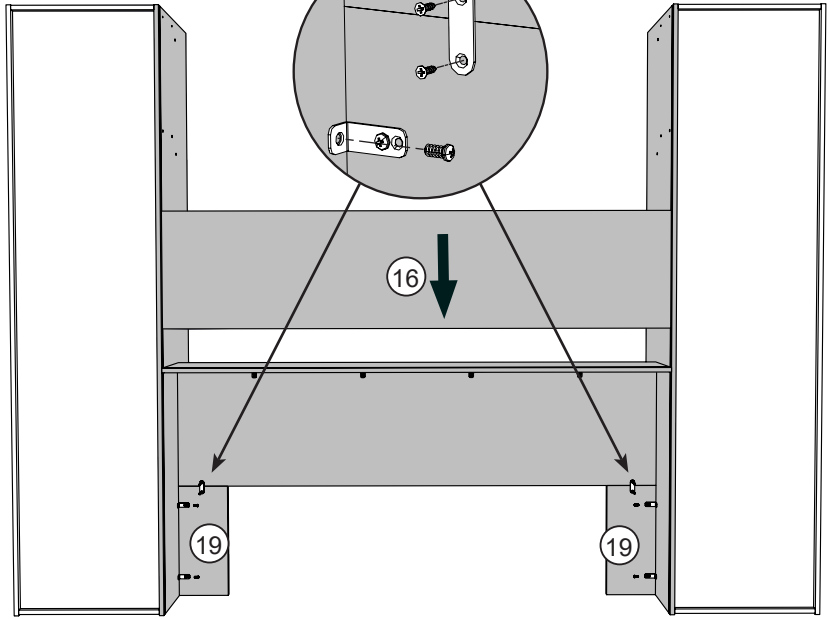
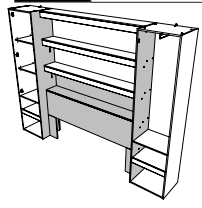
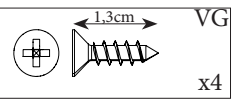
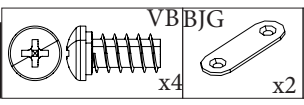

20

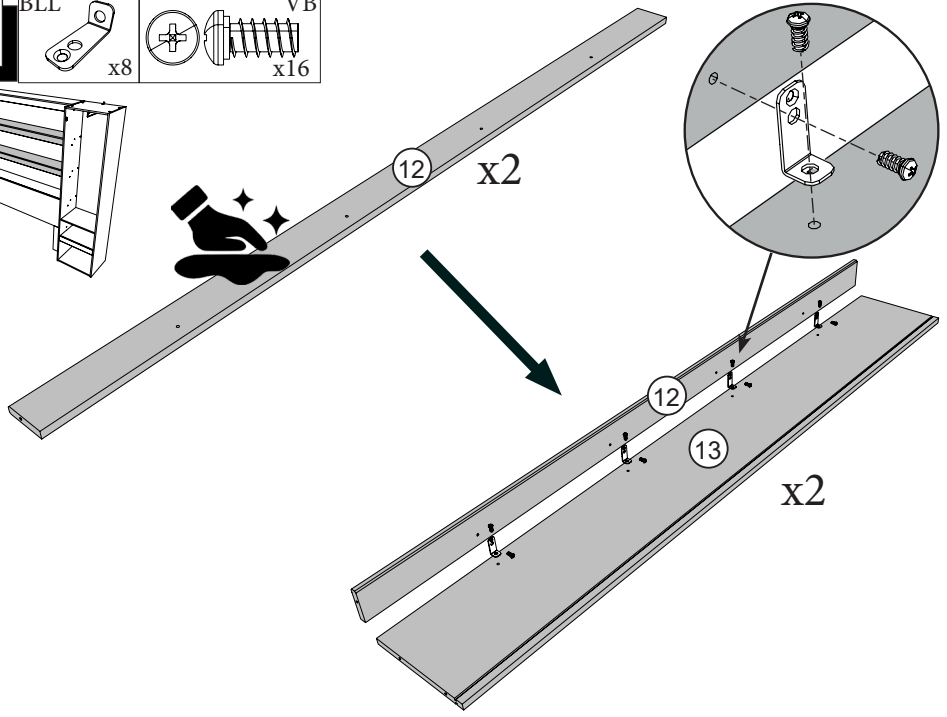
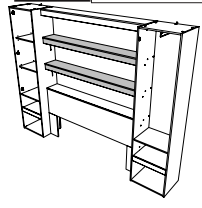
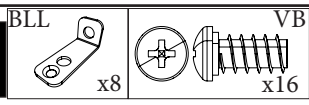

21 CUC x2

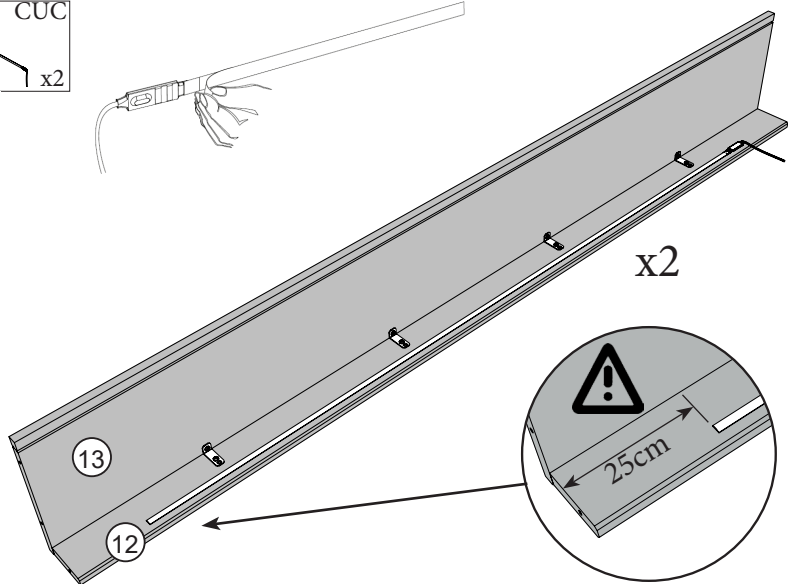
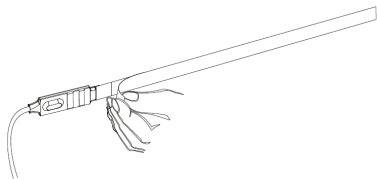

22

HW/HV x6

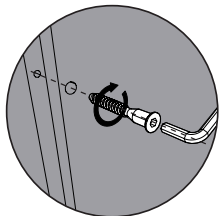
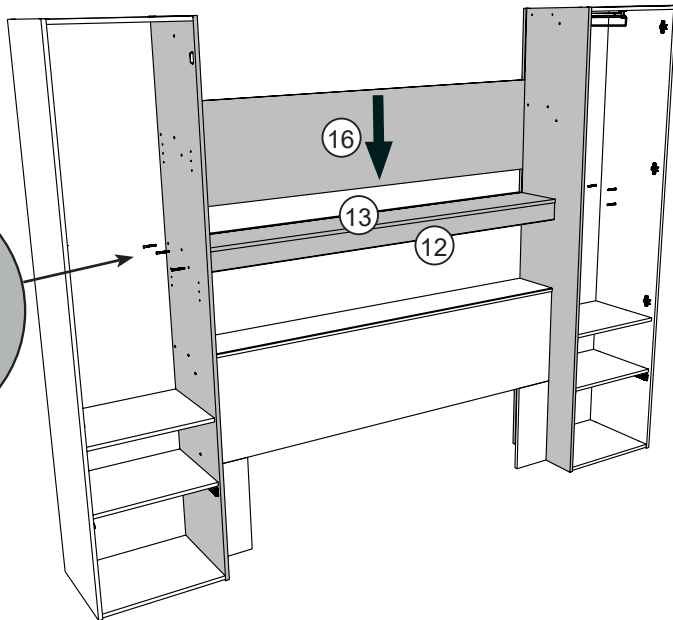
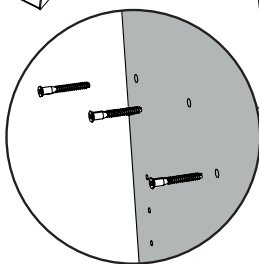
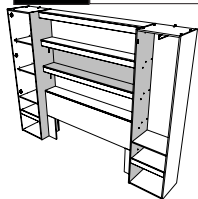

23

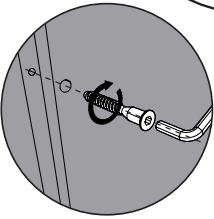
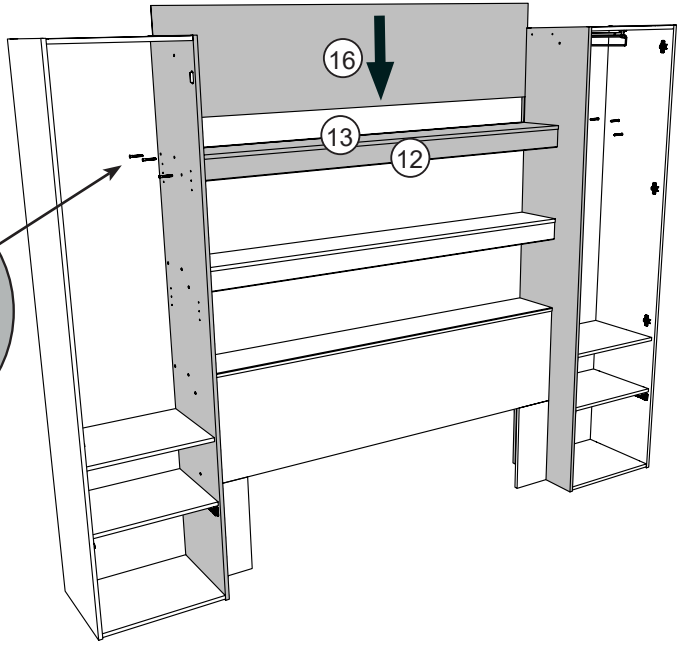
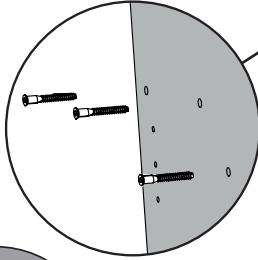
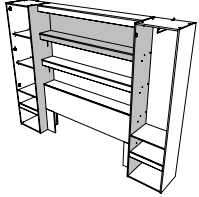
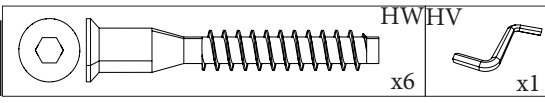

24

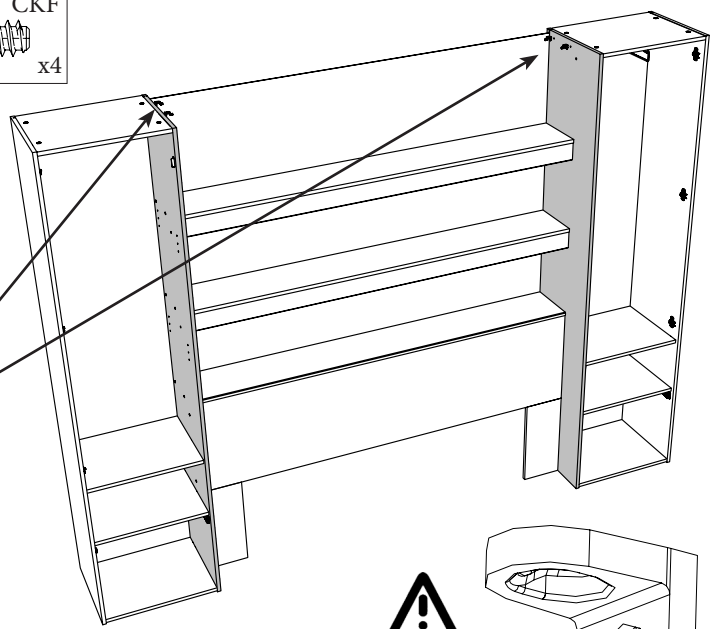
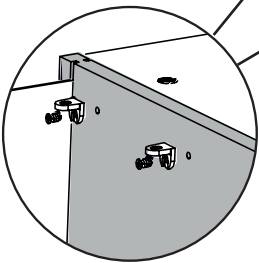
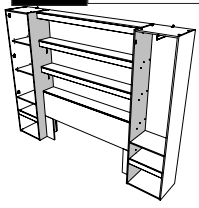
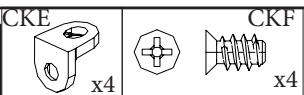

Bas
Floor

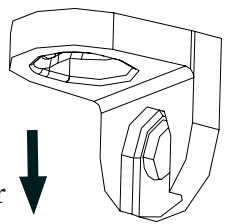

25 BLL x4 VB x8

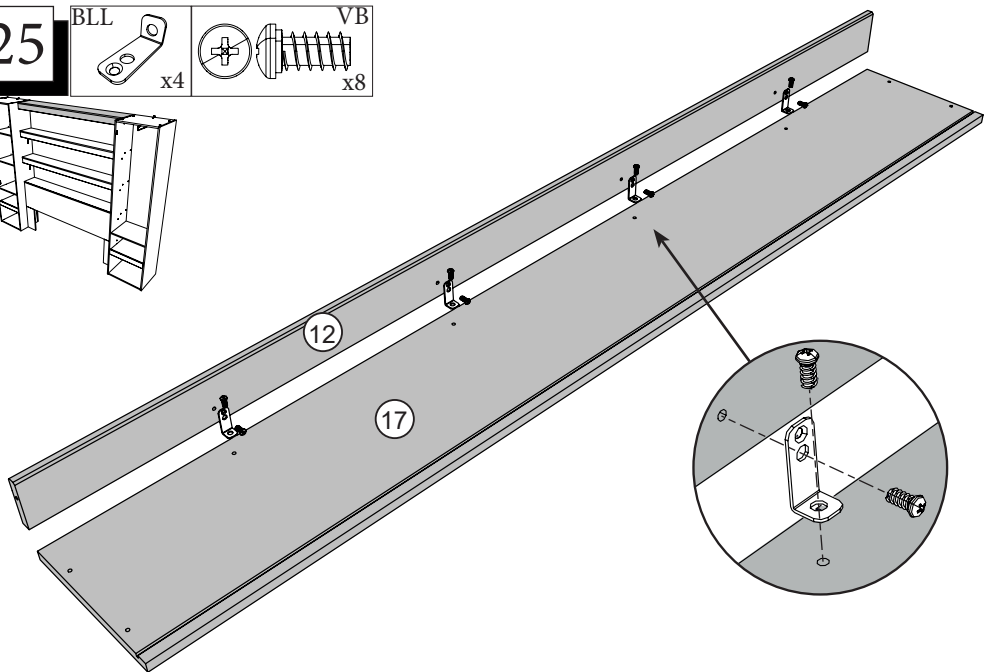
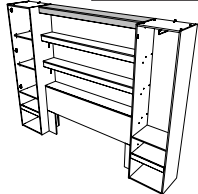

26 CKF x4 HWHV x2

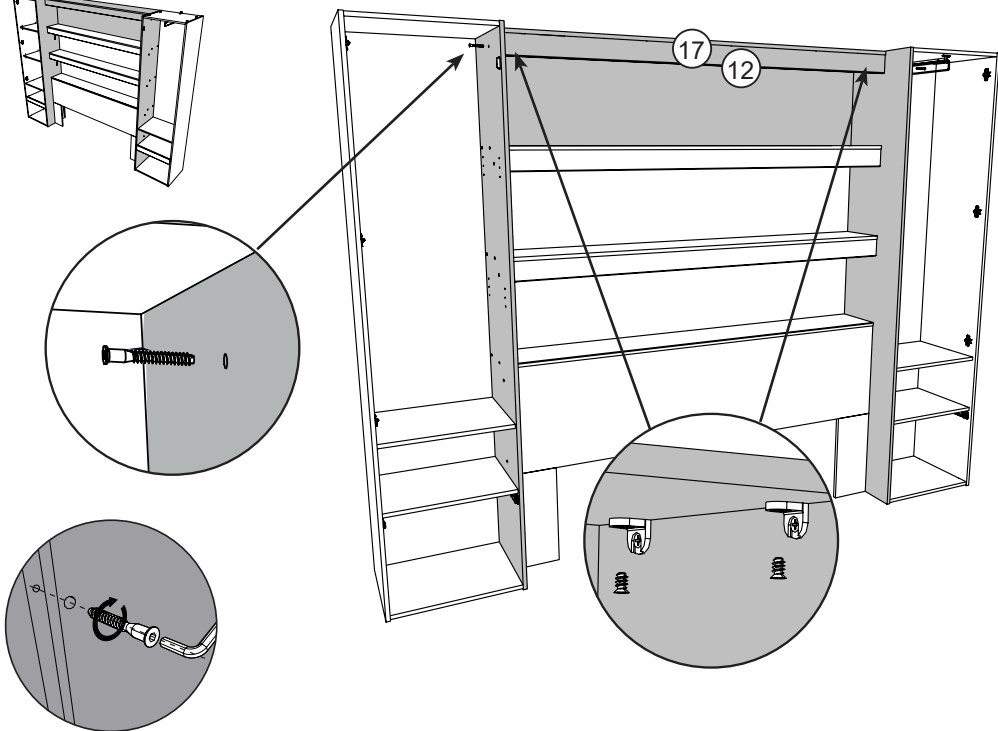
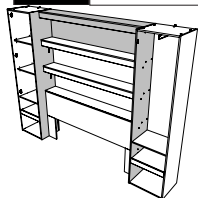

27

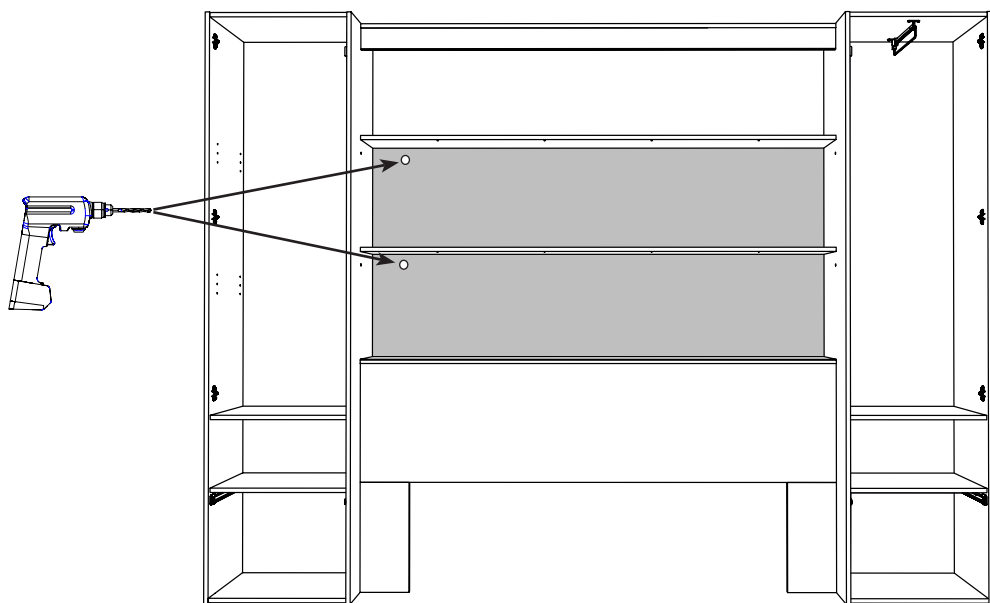
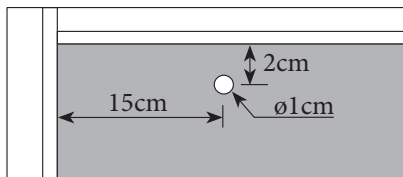
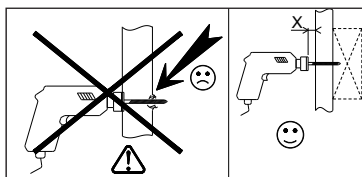
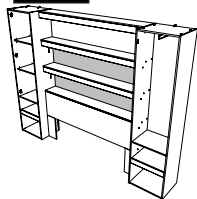

FR-Passez les câbles dans les trous effectués et fixez les à l'aide des 4 clips autocollants fournis, puis suivez les instructions de la notice du Kit LED pour le reste du câblage.

EN-Pass the cables through the holes previously made and secure them using the 4 self-adhesive clips provided, then follow the instructions in the LED Kit manual for the rest of the wiring.



28

EP



x10

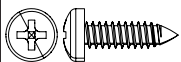

VE

x4

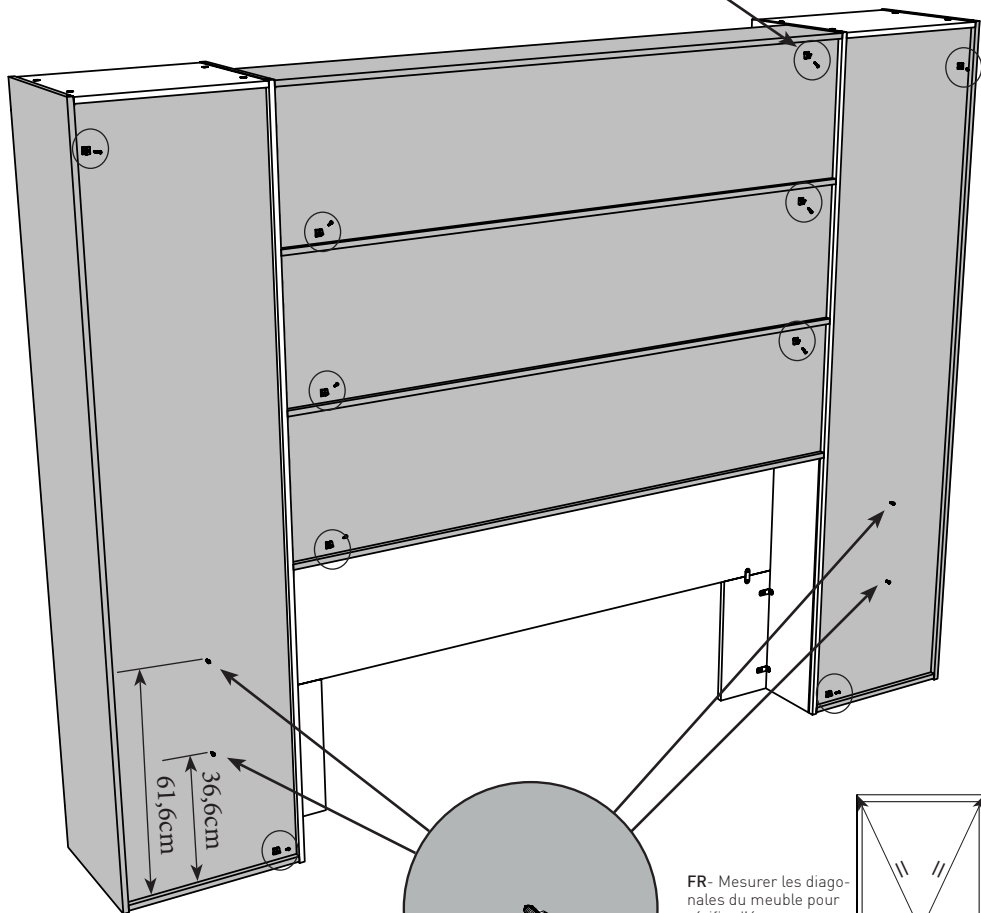
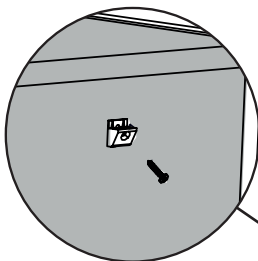
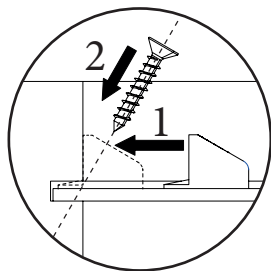
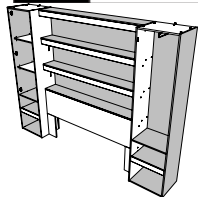

FR- Mesurer les diagonales du meuble pour vérifier l'équerrage. La mesure doit être identique.

EN- Measure the diagonals of the piece of furniture to check for straightening. The measurement must be identical.

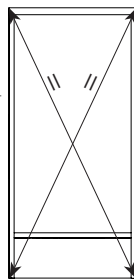

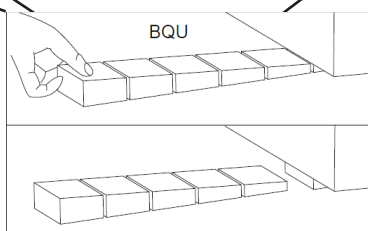
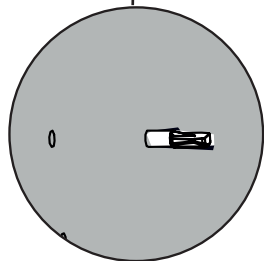
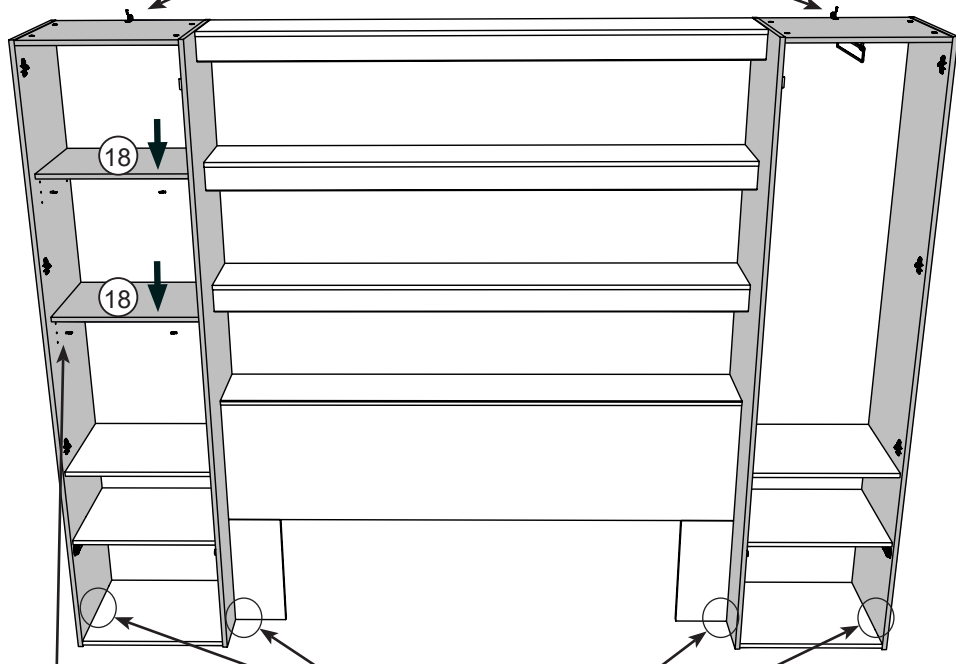
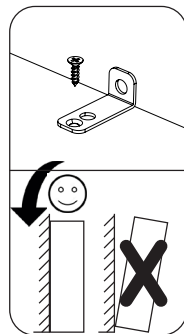
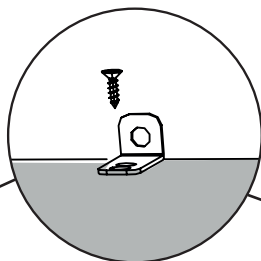
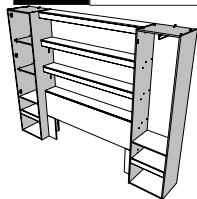
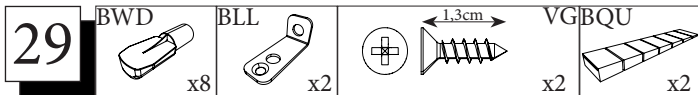

FR-Si besoin de perfectionner l'équerrage
EN-If necessary to perfect the squareness

FR-Pour votre sécurité : Fixation du meuble au mur.

Attention, la fixation doit être réalisée par une personne compétente car cela nécessite des chevilles adaptées à la nature de votre mur.

EN-For your safety : the unit should be secured to the wall.

NB this should be carried out by a competent person as you must use the right rawl plug for your type of wall.

30

VTB5 BWY



x10



x6

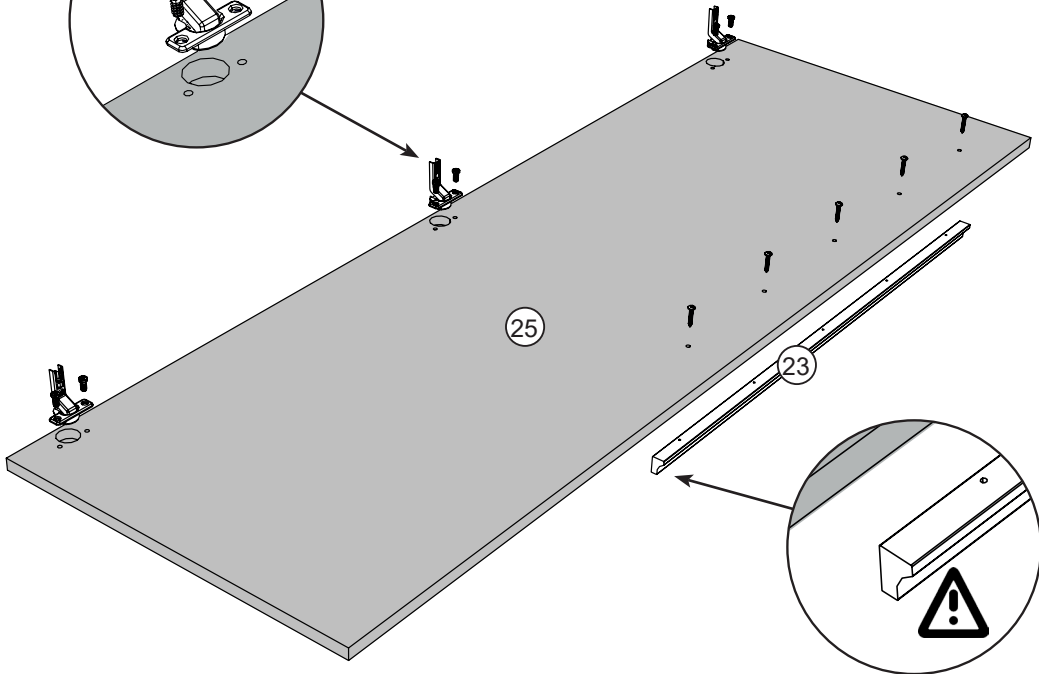
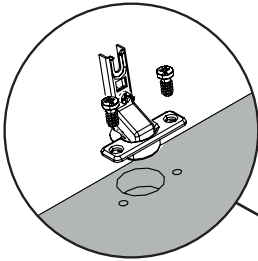
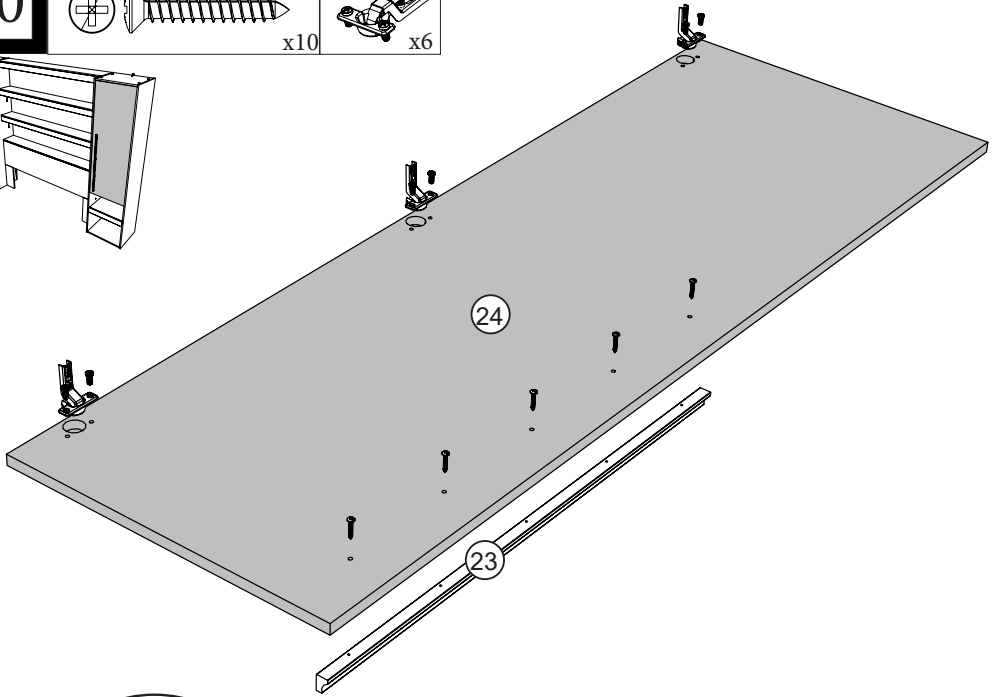
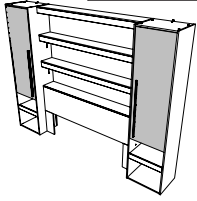

31

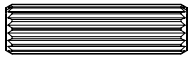

ADM
x4

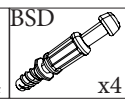
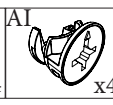

BSD
x4

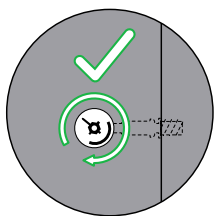
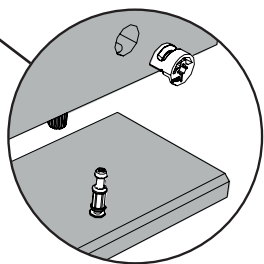
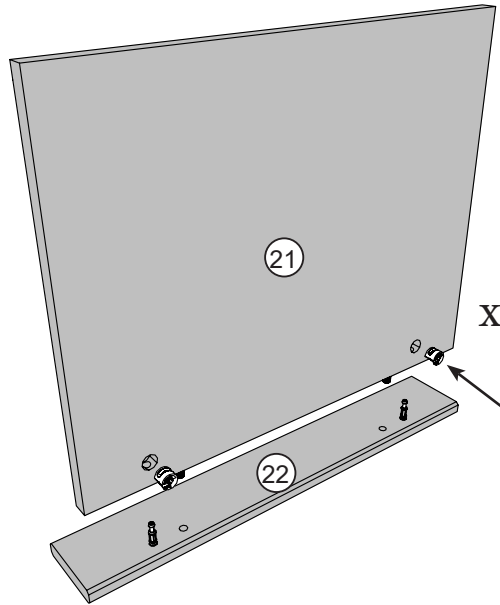
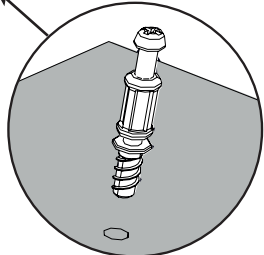
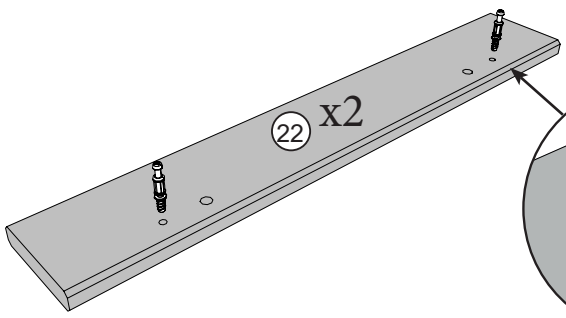
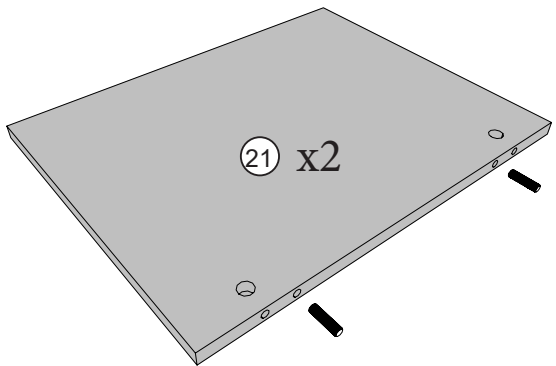
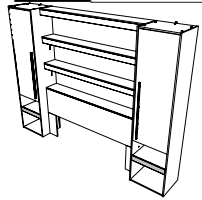

32



VI
x8



AFi x2



AFJ x2

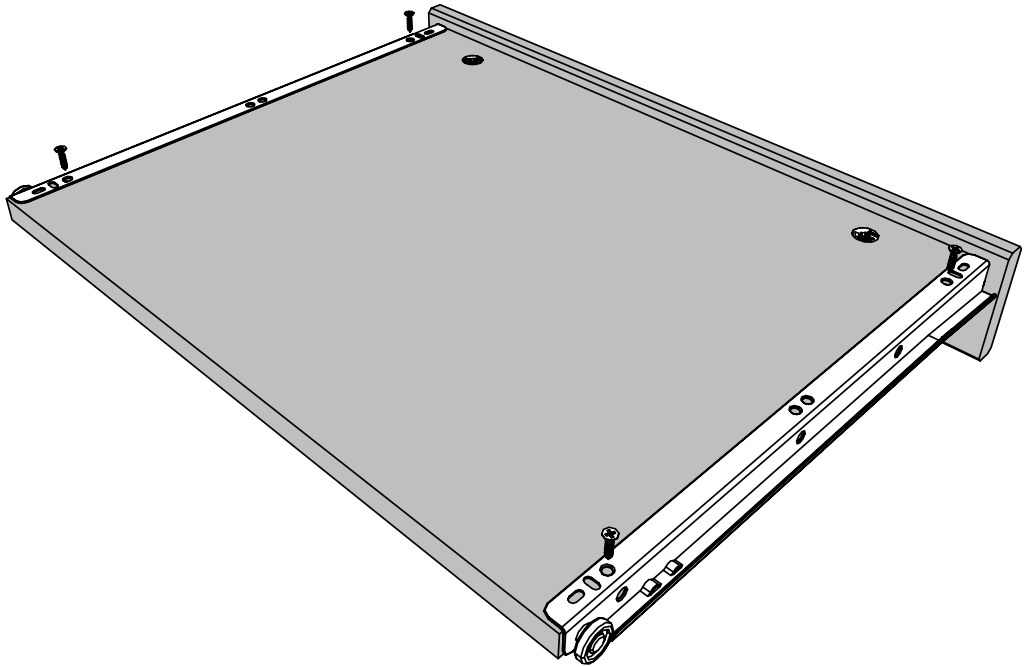
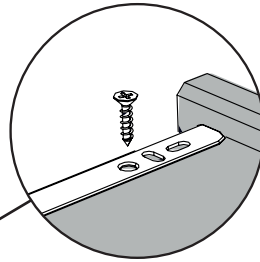
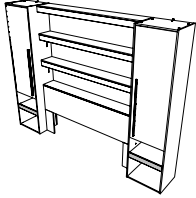

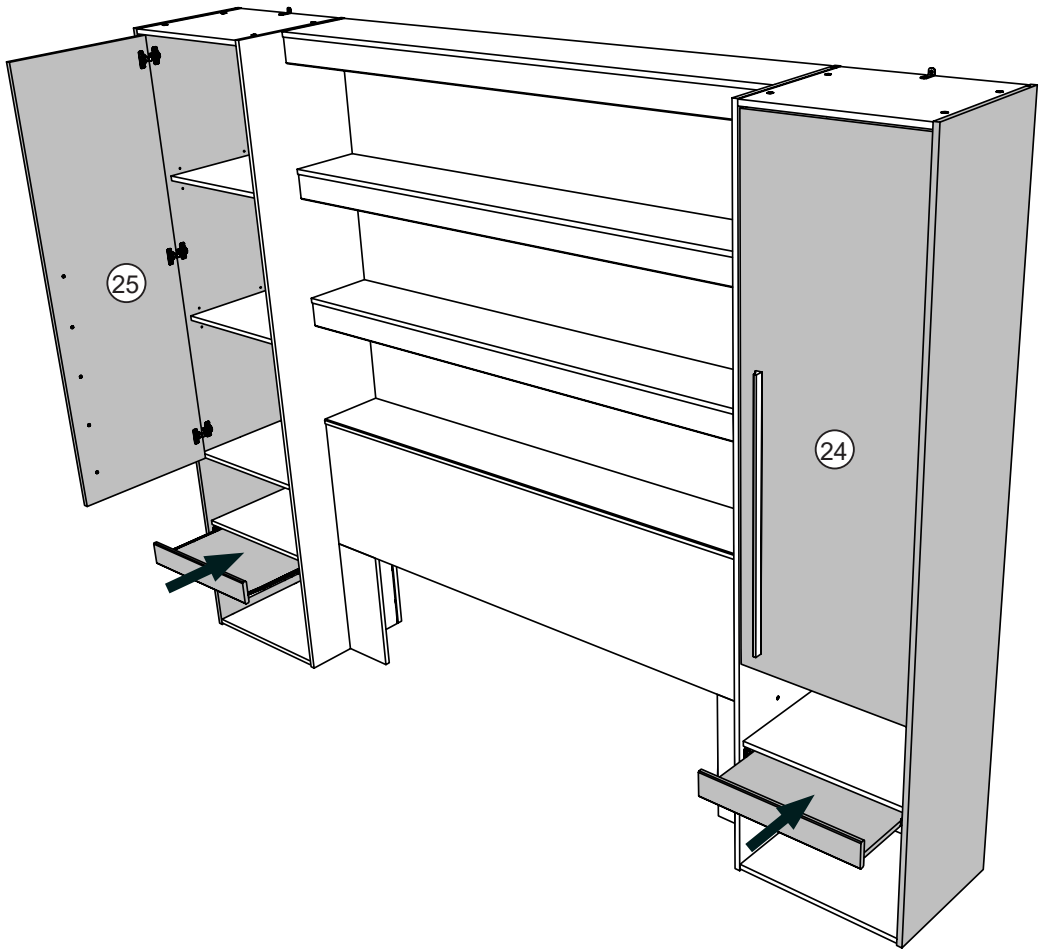

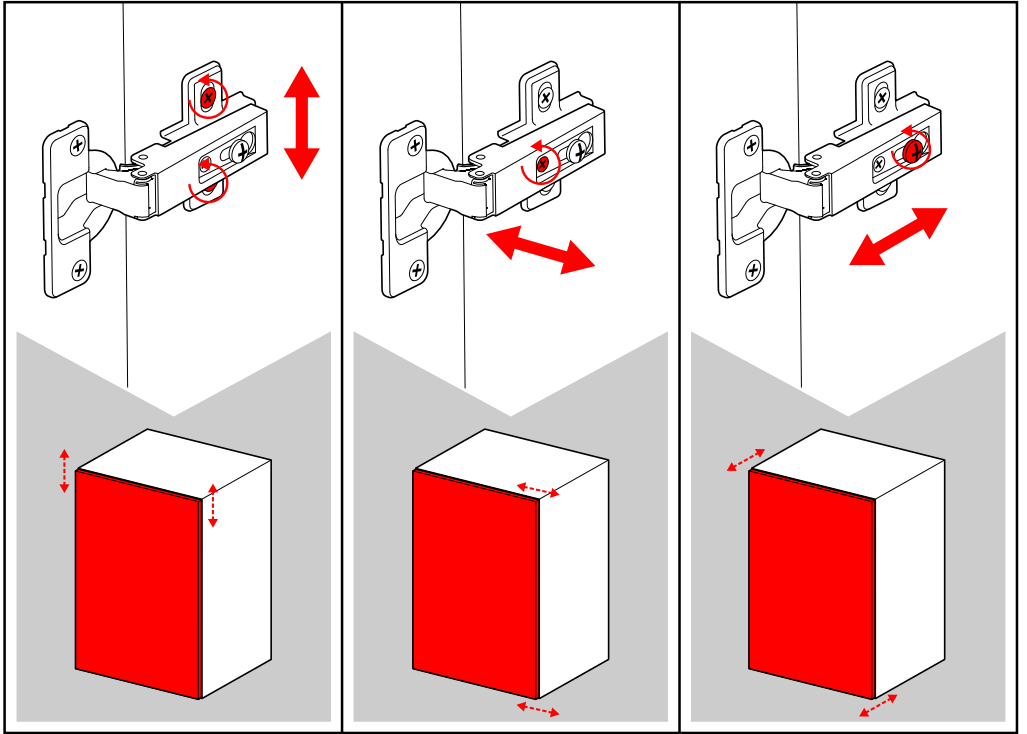

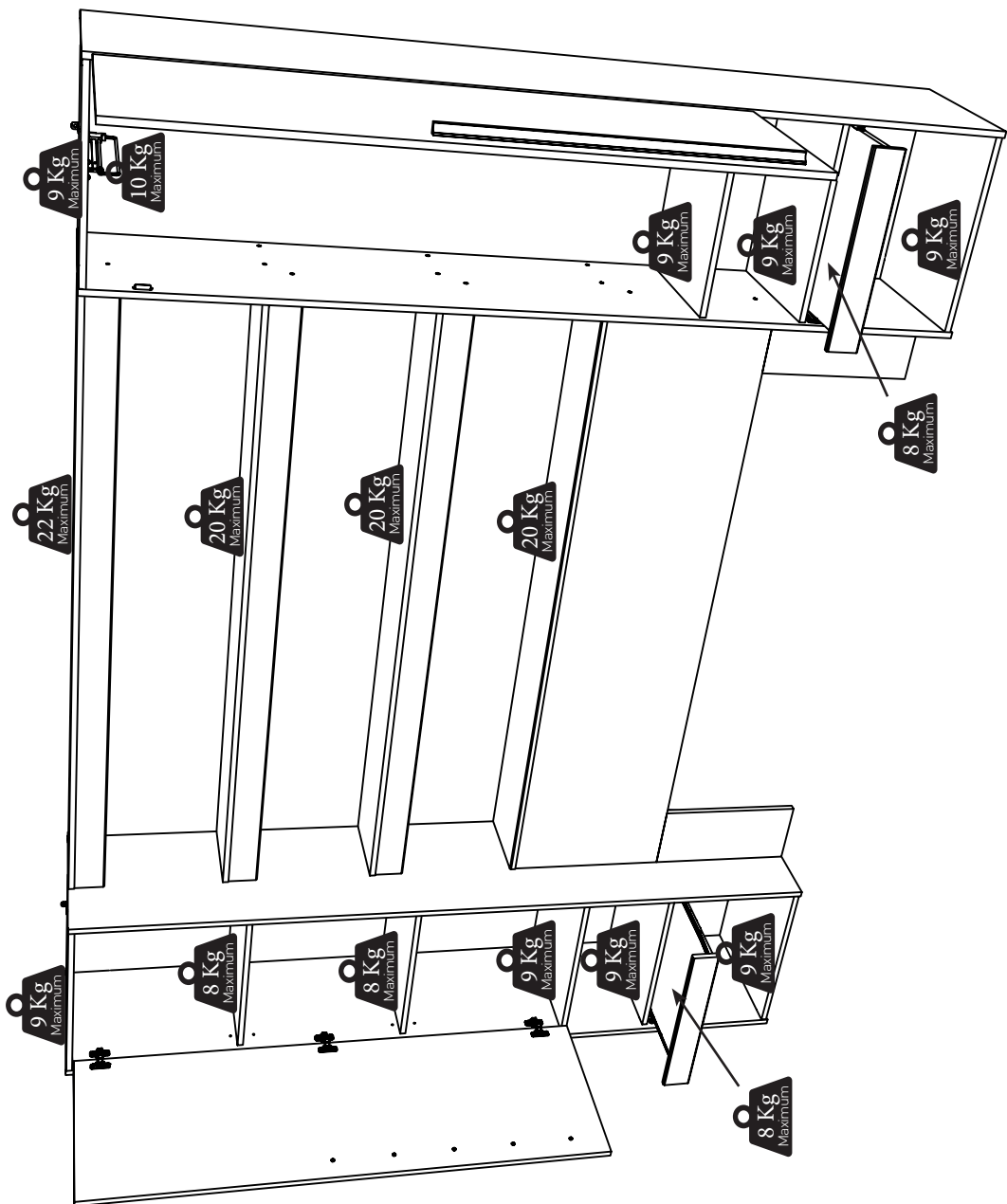

**LE TRI
+ FACILE**



FR

**Pensez à
donner ou recycler.**



OU



OU



Association

Magasin

Déchèterie

<https://quefairedemesdechets.fr>



LIT 160

3123L260

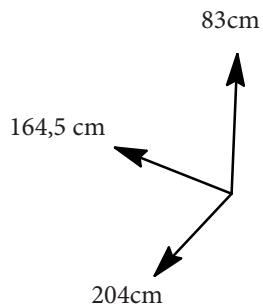
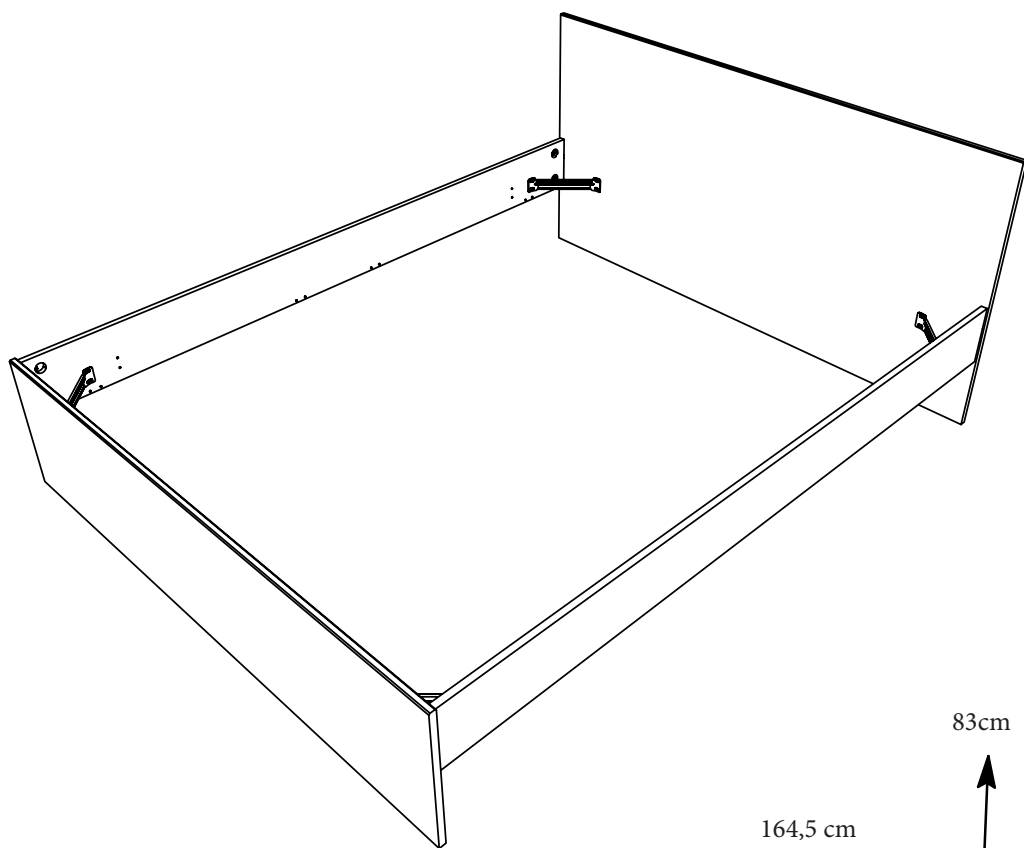

FR Remerciements :

Nous vous remercions d'avoir choisi un meuble créé et fabriqué par le Groupe Parisot et espérons qu'il vous donnera entière satisfaction.

EN Thanks:

Thank you for choosing furniture designed and manufactured by the Parisot Group.
We hope you are totally satisfied with your purchase.

DE Danksagung:

Wir danken Ihnen für den Kauf eines Frankreich von der Parisot-Gruppe entworfenen und hergestellten Möbelstücks und hoffen, dass Sie es zu Ihrer vollkommenen Zufriedenheit finden werden.

HU Köszönet:

Köszönjük, hogy a Parisot Groupe által létrehozott és gyártott bútort választott, reméljük, hogy elégedett lesz a termékkel.

PT Agradecimentos:

Obrigado por ter escolhido um móvel concebido e fabricado pelo Grupo Parisot, esperando que seja do seu inteiro agrado.

IT Ringraziamenti:

Grazie per avere scelto un mobile progettato e fabbricato dal Gruppo Parisot. Speriamo soddisfi appieno le vostre esigenze.

NL Bedankje:

Wij bedanken u voor de aankoop van een door de Groep Parisot ontworpen en vervaardigd meubel en hopen dat u er veel plezier aan zult beleven.

CZ Poděkování:

Děkujeme, že jste si vybrali nábytek navržený a vyrobený společností Parisot Group. Doufáme, že budete svým nákupem naprosto spokojeni.

ES Agradecimientos:

Les damos las gracias por haber elegido un mueble diseñado y fabricado por el Groupe Parisot y esperamos que sea de su total agrado.

PL Podziękowania:

Dziękujemy za wybór mebli stworzonych i wyprodukowanych przez Grupę Parisot. Mamy nadzieję, że będziecie Państwo w pełni zadowoleni z zakupu.

SK Pod'akovanie:

Ďakujeme, že ste si vybrali nábytok navrhnutý a vyrobený spoločnosťou Parisot Group. Dúfame, že budete svojim nákupom absolútne spokojní.

AR تشكر:

تشكرکم لاختيارکم هذه القطعة من الأثاث من تصميم وتصنيع مجموعة باريسو Parisot وتتمنى أن تنال رضائکم.



30Mn

PARISOT INDUSTRIE

15 Avenue Jacques Parisot, 70800 Saint-Loup sur Semouse
RCS VESOUL 537 665 200 contact@parisot.com

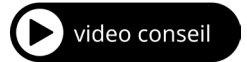

<https://qrco.de/bcJeNz>

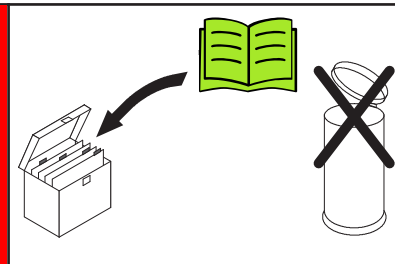
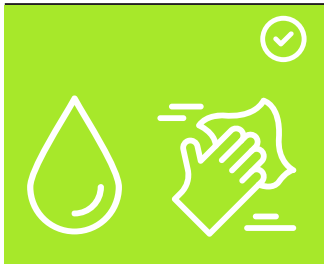
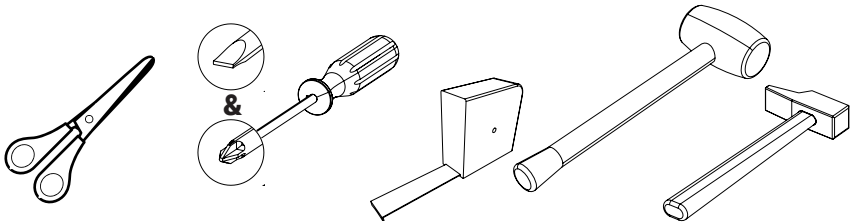

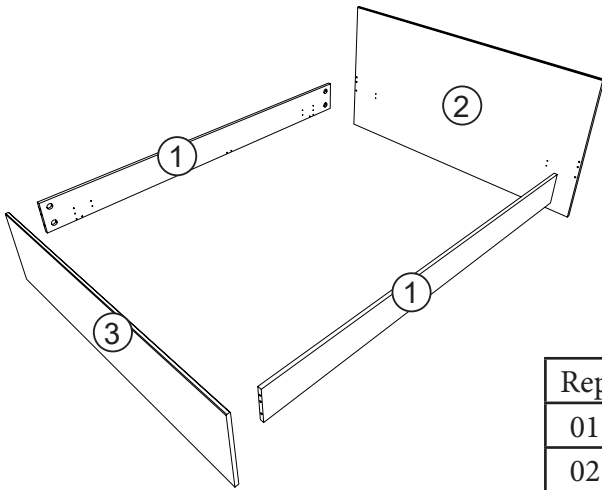

Rep	Qté	cm		
		Long.	Larg.	Ep.
01	2	200	17,4	1,8
02	1	164,4	82,6	1,8
03	1	164,4	39,7	1,8

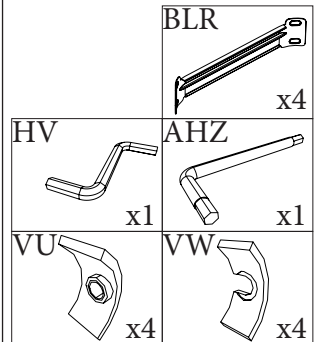
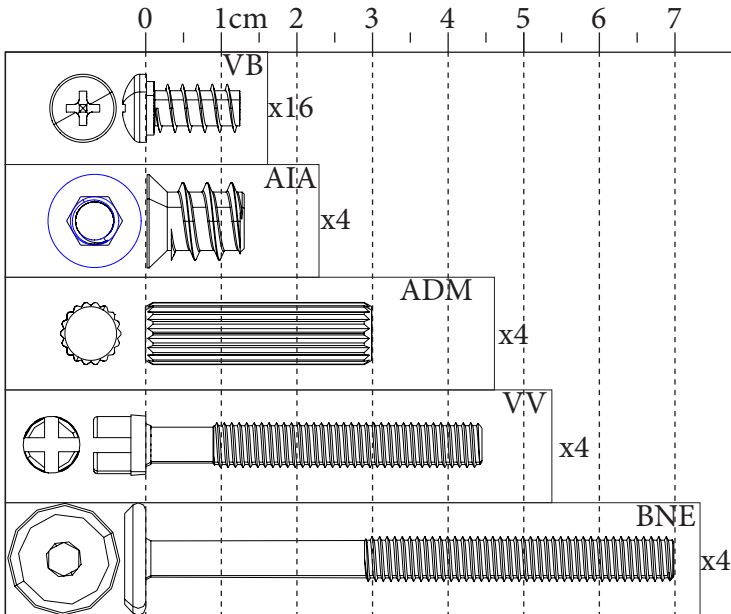

0094NOTIC6351

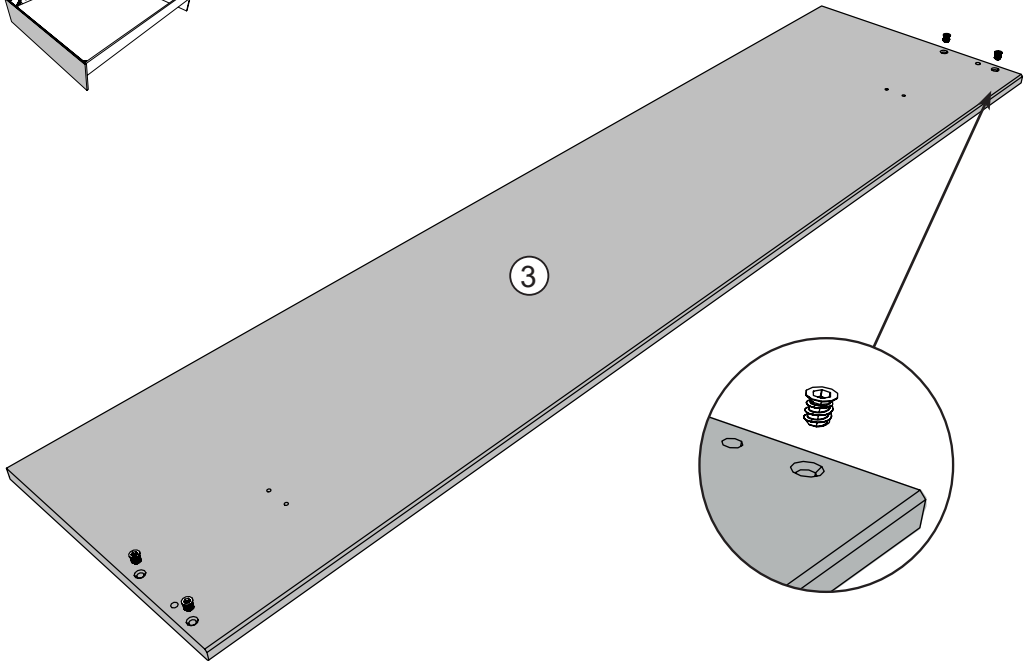
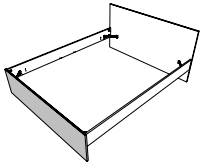
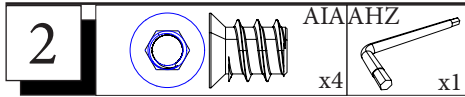
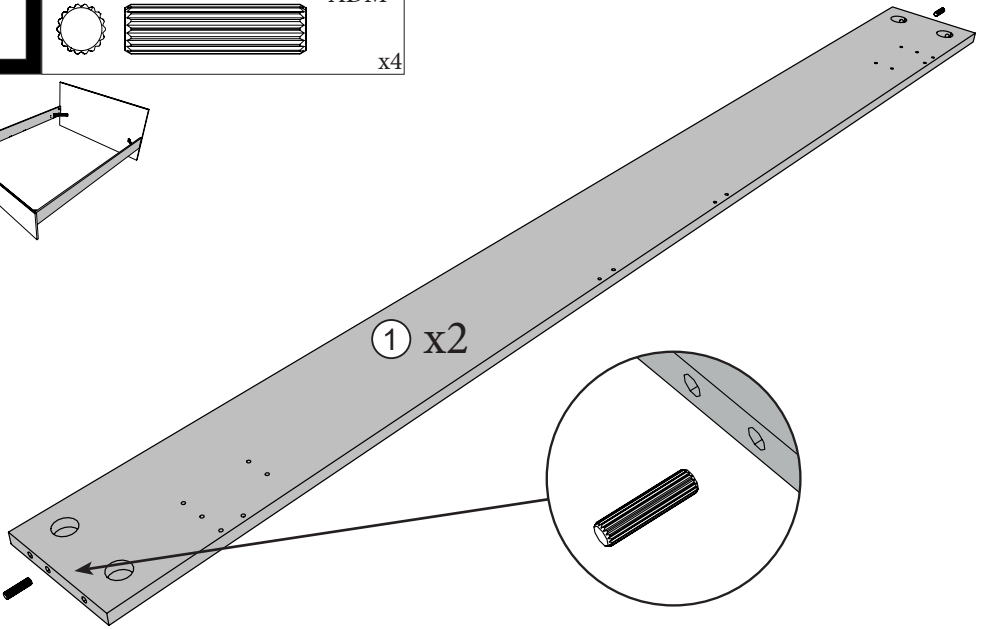
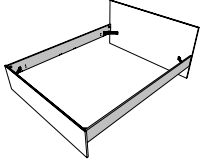
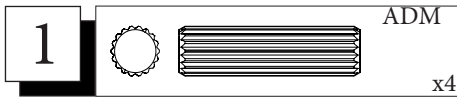

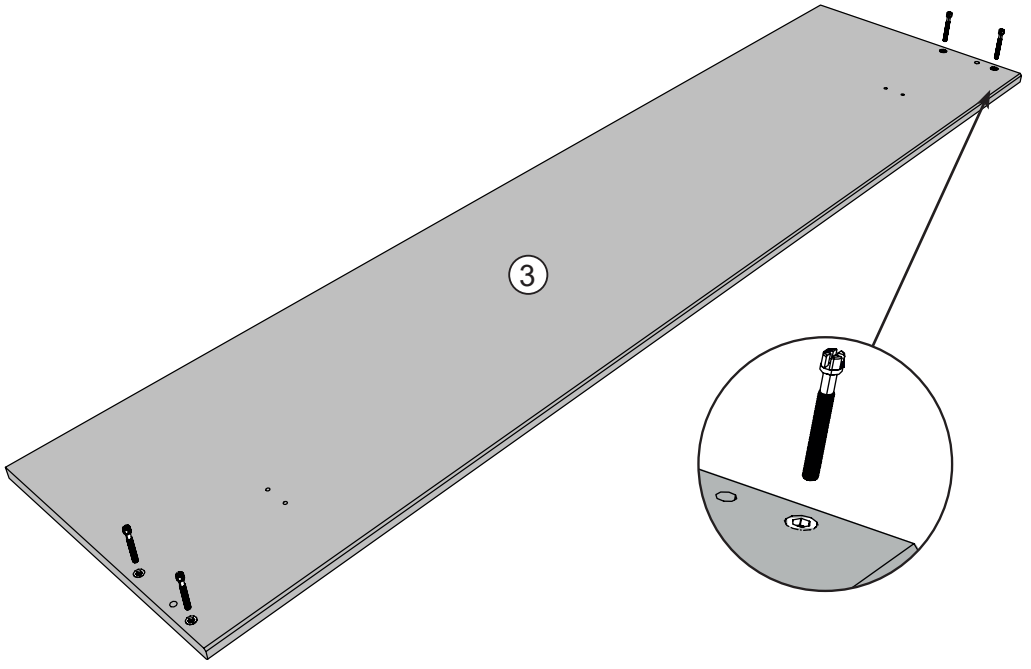
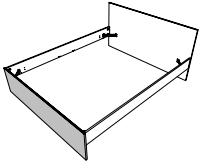
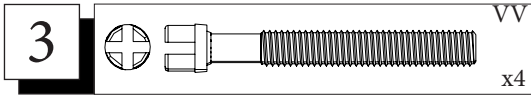

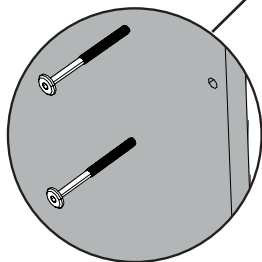
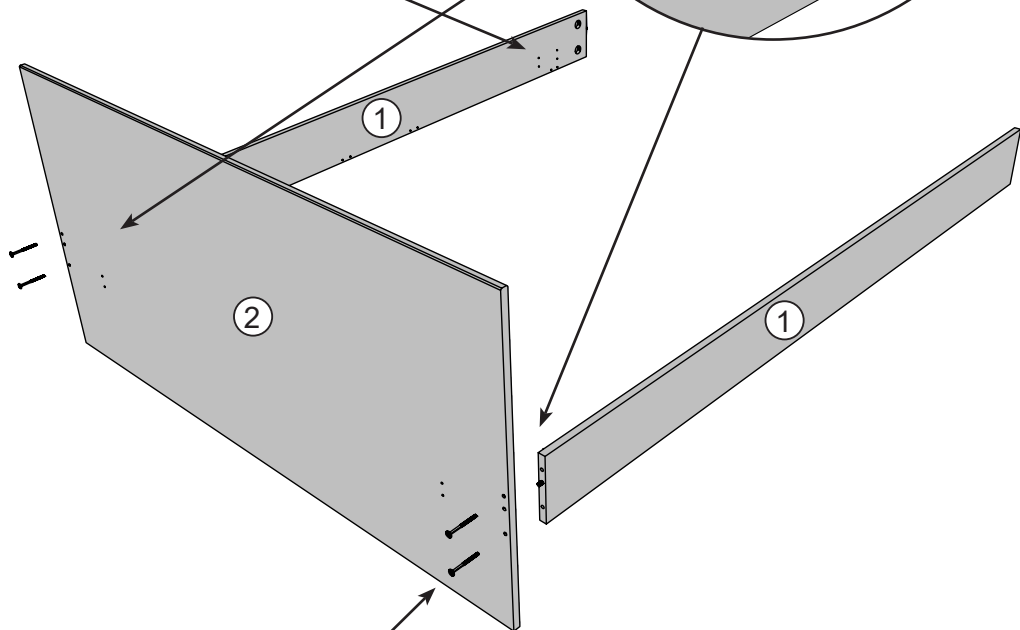
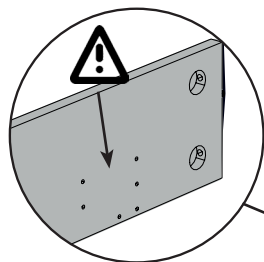
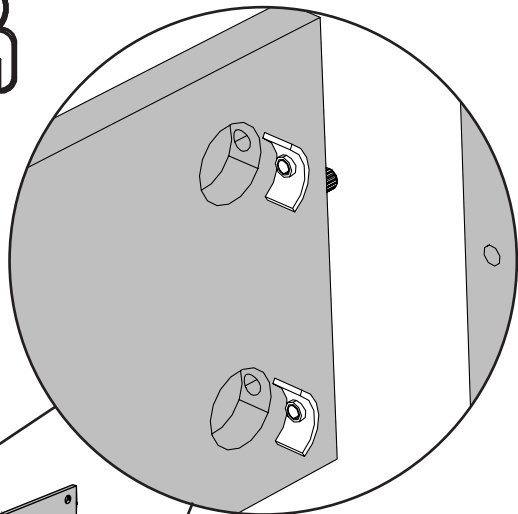
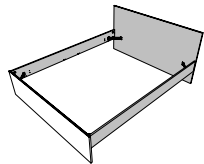
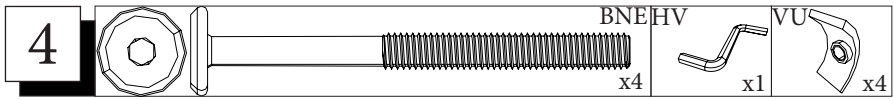

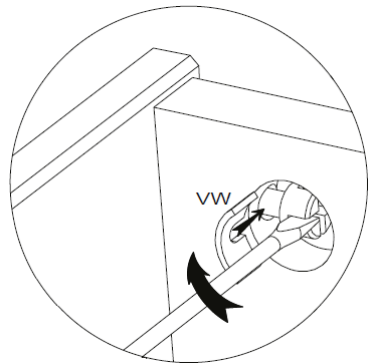
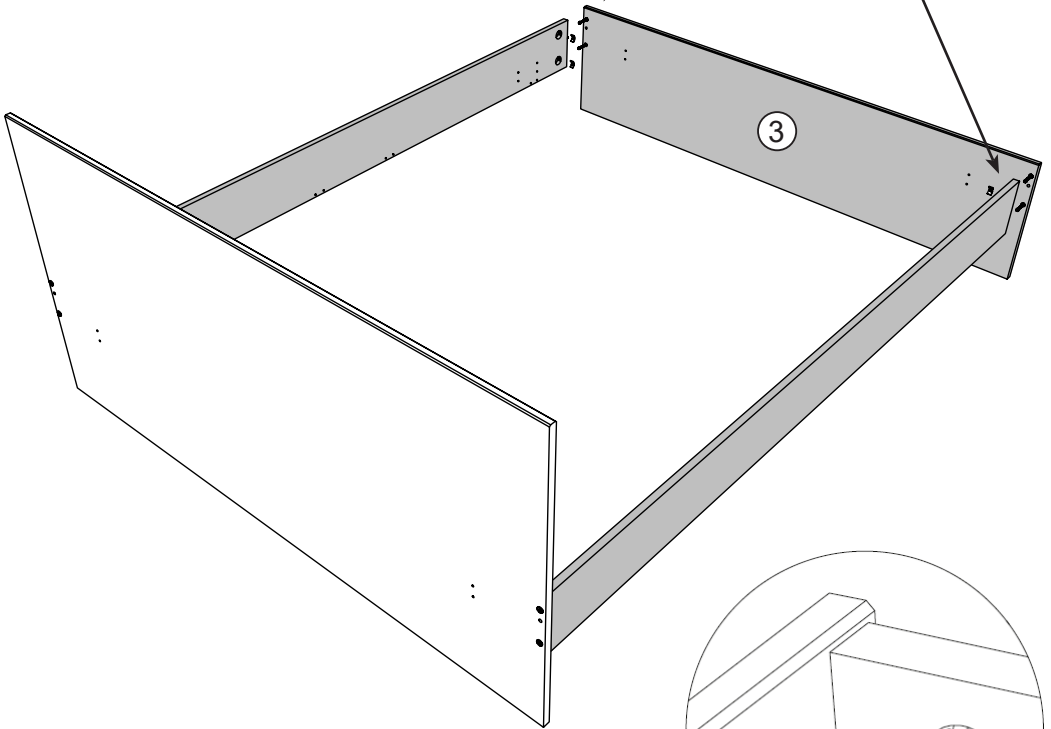
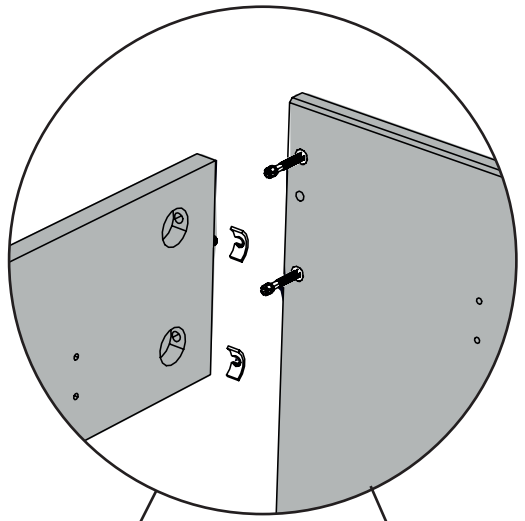
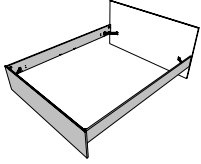

6

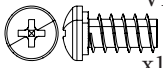

VBBLR

x16

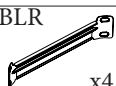

x4

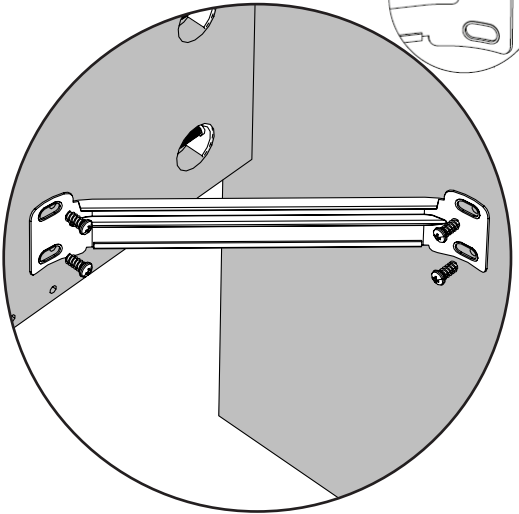
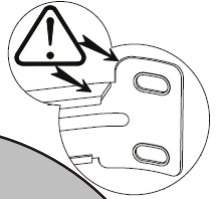
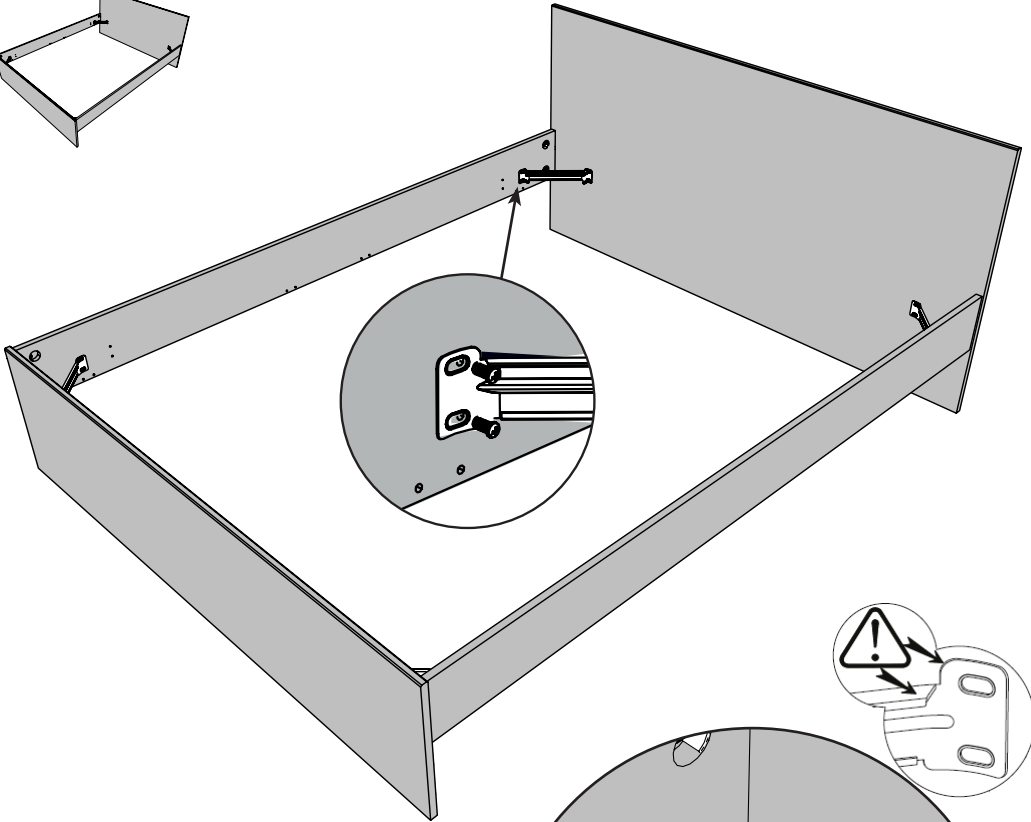
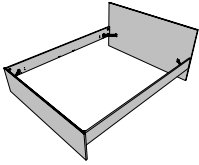

LE TRI
+ FACILE



FR

Pensez à
donner ou recycler.



Association

OU



Magasin

OU



Déchèterie

<https://quefairedemesdechets.fr>



Tiroir

3123TIRO

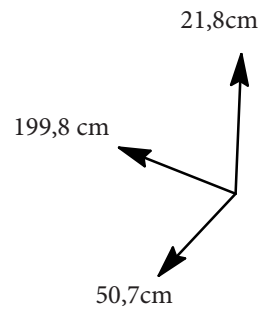
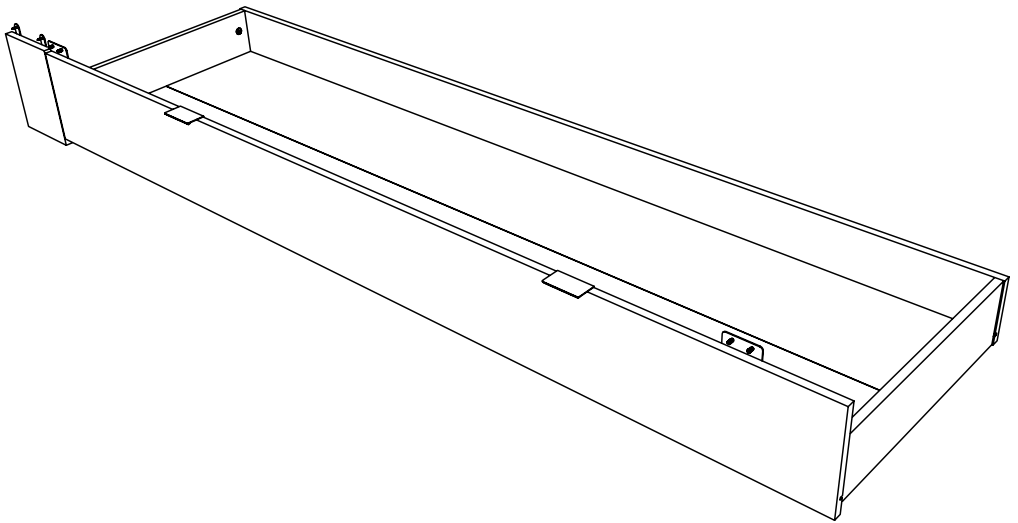

FR Remerciements :

Nous vous remercions d'avoir choisi un meuble créé et fabriqué par le Groupe Parisot et espérons qu'il vous donnera entière satisfaction.

EN Thanks:

Thank you for choosing furniture designed and manufactured by the Parisot Group.
We hope you are totally satisfied with your purchase.

DE Danksagung:

Wir danken Ihnen für den Kauf eines Frankreich von der Parisot-Gruppe entworfenen und hergestellten Möbelstücks und hoffen, dass Sie es zu Ihrer vollkommenen Zufriedenheit finden werden.

HU Köszönet:

Köszönjük, hogy a Parisot Groupe által létrehozott és gyártott bútort választott, reméljük, hogy elégedett lesz a termékkel.

PT Agradecimentos:

Obrigado por ter escolhido um móvel concebido e fabricado pelo Grupo Parisot, esperando que seja do seu inteiro agrado.

IT Ringraziamenti:

Grazie per avere scelto un mobile progettato e fabbricato dal Gruppo Parisot. Speriamo soddisfi appieno le vostre esigenze.

NL Bedankje:

Wij bedanken u voor de aankoop van een door de Groep Parisot ontworpen en vervaardigd meubel en hopen dat u er veel plezier aan zult beleven.

CZ Poděkování:

Děkujeme, že jste si vybrali nábytek navržený a vyrobený společností Parisot Group. Doufáme, že budete svým nákupem naprosto spokojeni.

ES Agradecimientos:

Les damos las gracias por haber elegido un mueble diseñado y fabricado por el Groupe Parisot y esperamos que sea de su total agrado.

PL Podziękowania:

Dziękujemy za wybór mebli stworzonych i wyprodukowanych przez Grupę Parisot. Mamy nadzieję, że będziecie Państwo w pełni zadowoleni z zakupu.

SK Pod'akovanie:

Ďakujeme, že ste si vybrali nábytok navrhnutý a vyrobený spoločnosťou Parisot Group. Dúfame, že budete svojim nákupom absolútne spokojní.

AR تشكر:

نشكركم لاختياركم هذه القطعة من الأثاث من تصميم وتصنيع مجموعة باريسو Parisot ونتمنى أن تنال رضائكم.



30Mn

PARISOT INDUSTRIE

15 Avenue Jacques Parisot, 70800 Saint-Loup sur Semouse
RCS VESOUL 537 665 200 contact@parisot.com

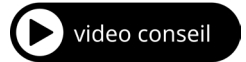

<https://qrco.de/bcJeNz>

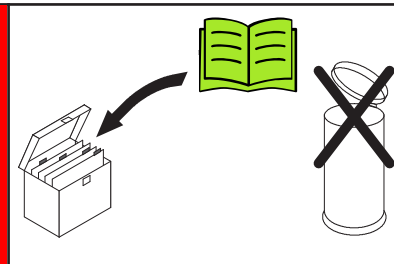
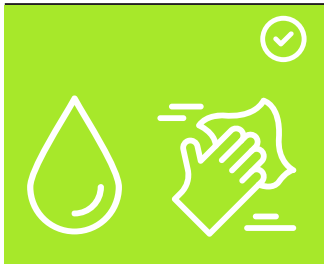
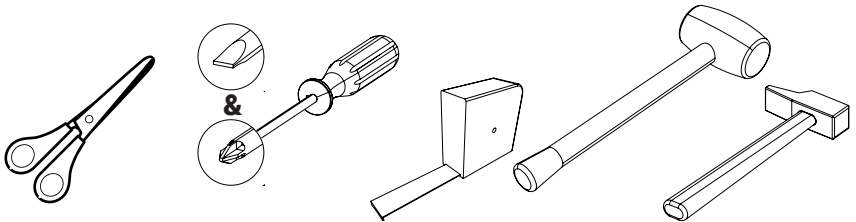

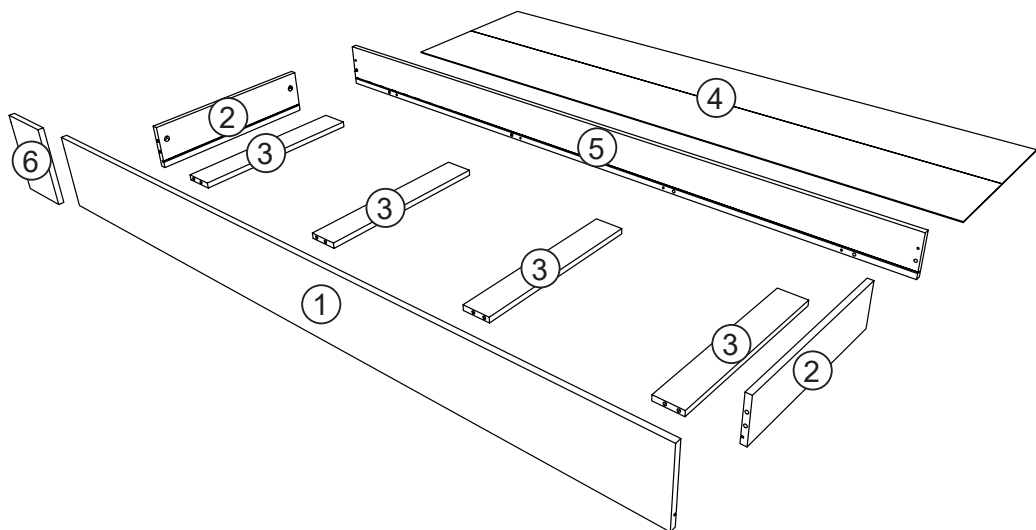

Rep	Qté	cm		
Rep	Qté	Long.	Larg.	Ep.
01	1	185	19,6	1,5
02	2	47,7	12	1,5
03	4	47,7	7,6	1,5
04	1	182,4	48,7	0,25
05	1	184,6	12,1	1,5
06	1	21,7	14,6	1,5

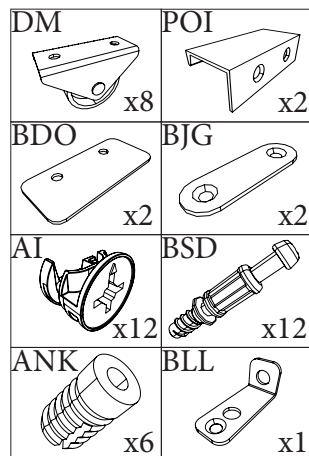
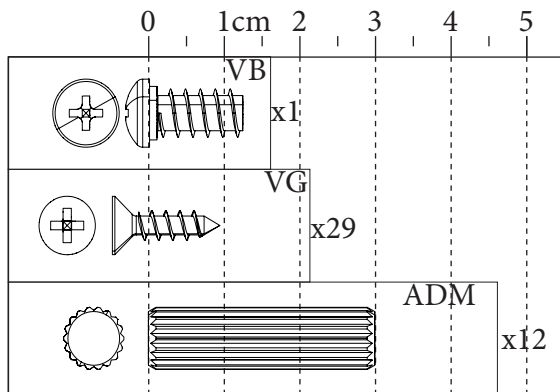

0094NOTIC6349

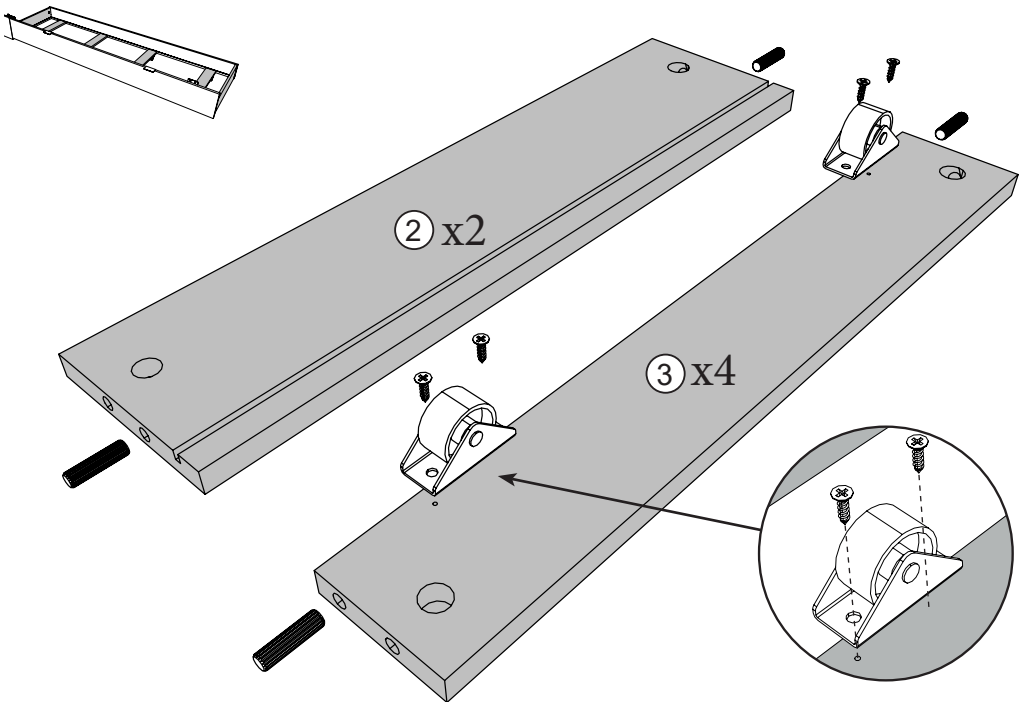
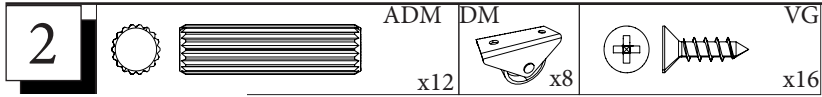
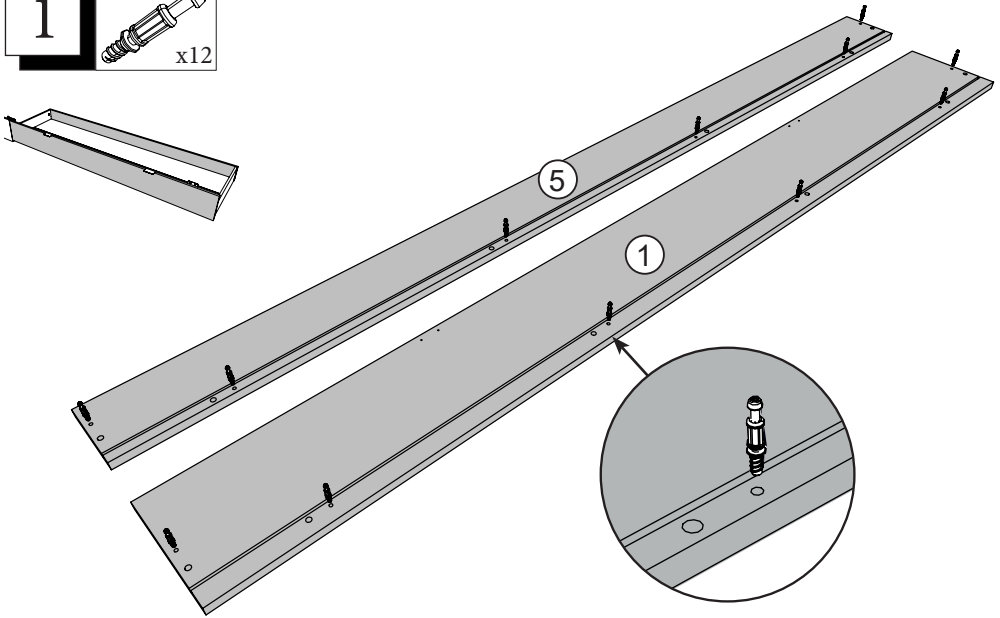
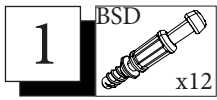

3 AI x6

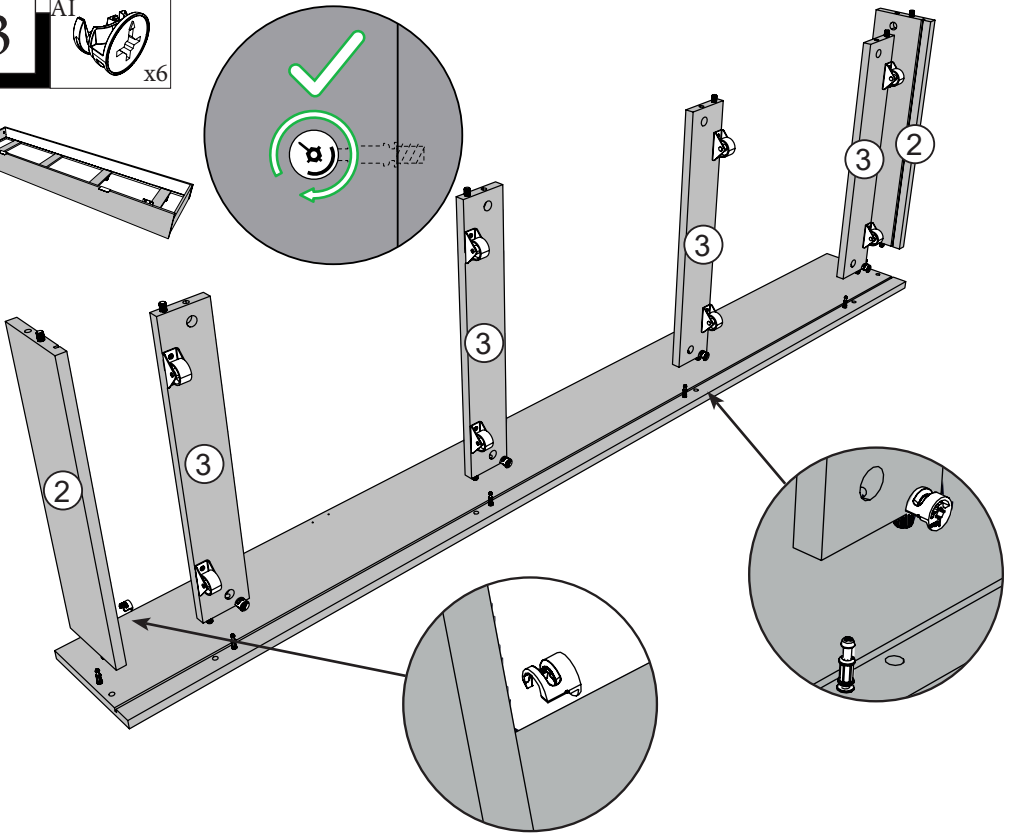
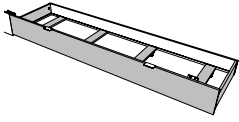
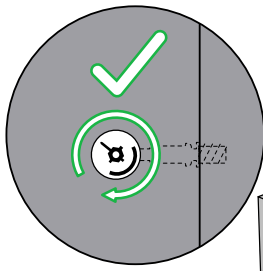

4

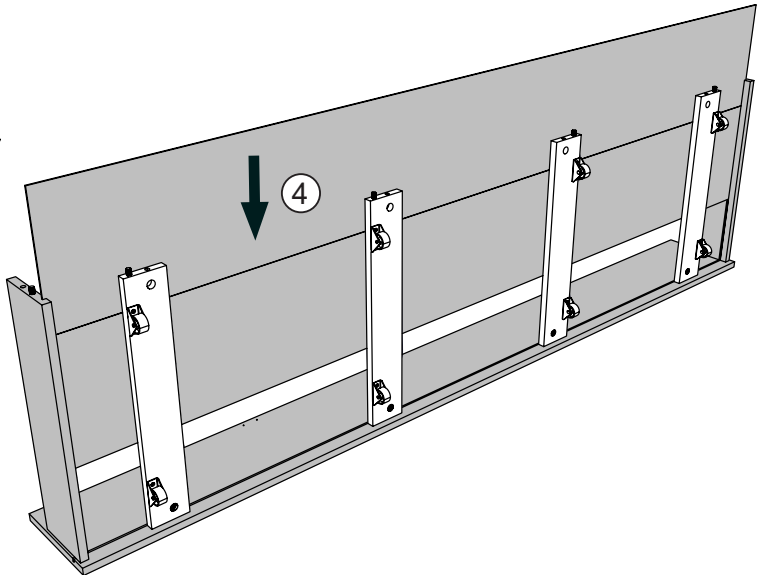
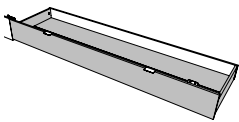

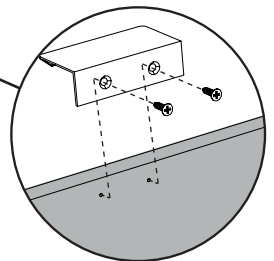
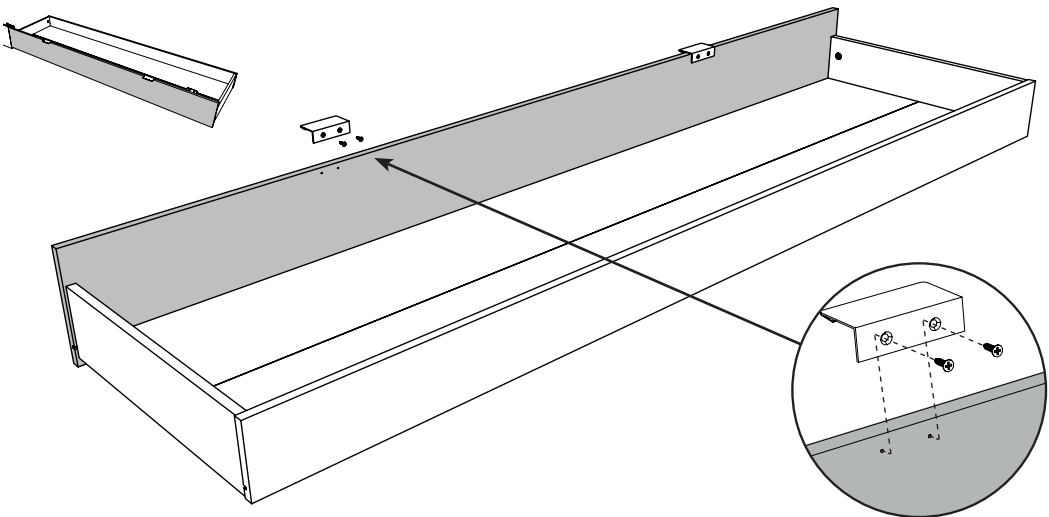
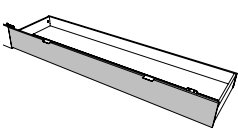
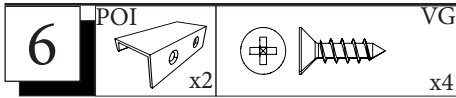
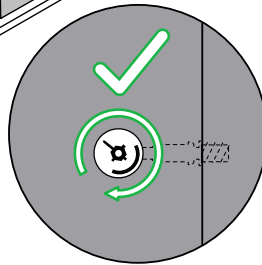
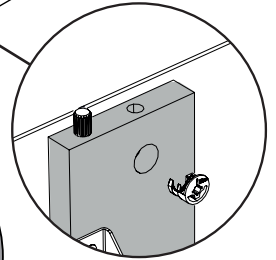
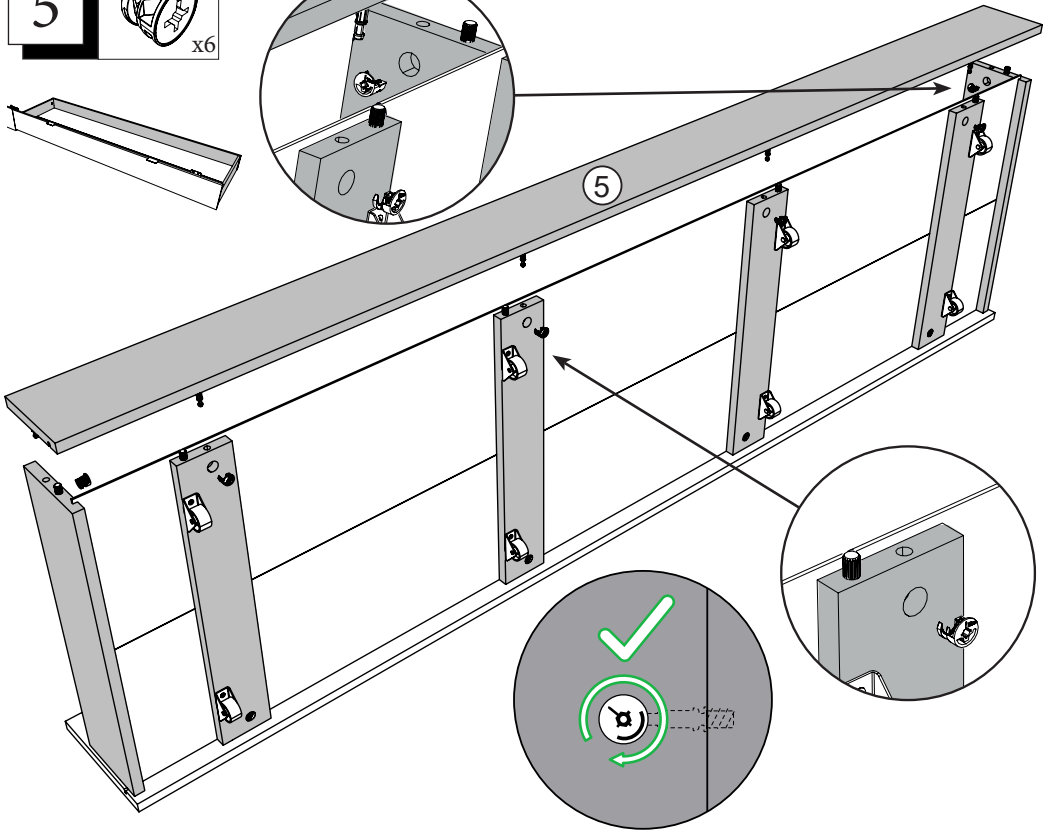
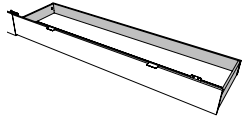
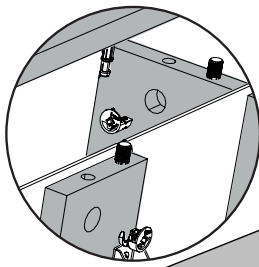
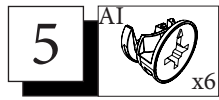

A

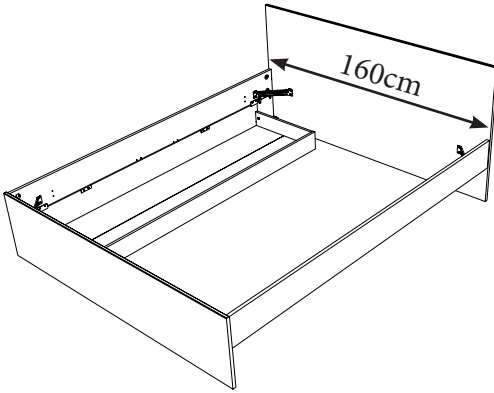

B

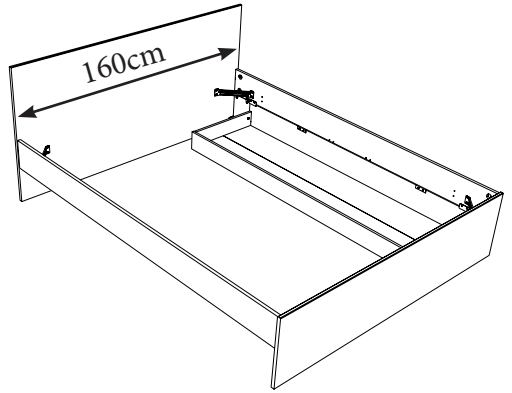

C

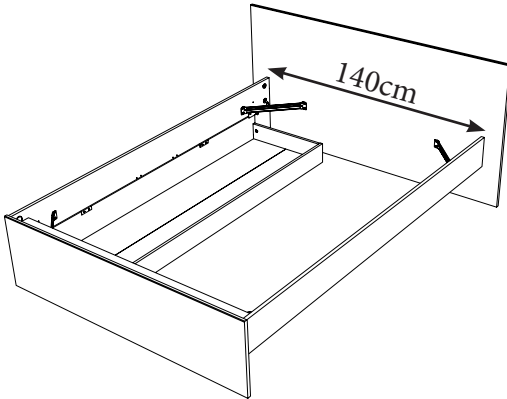

D

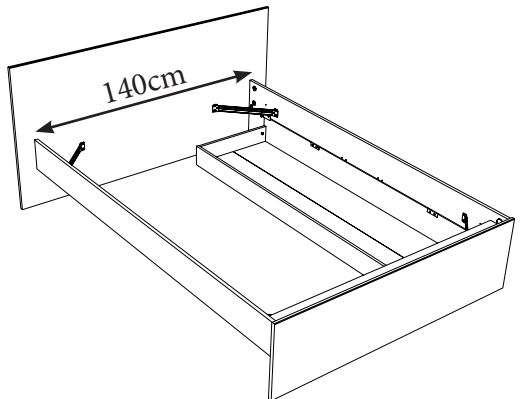

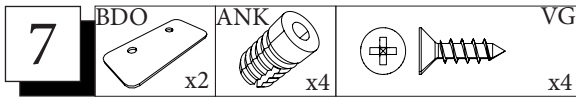

A-C

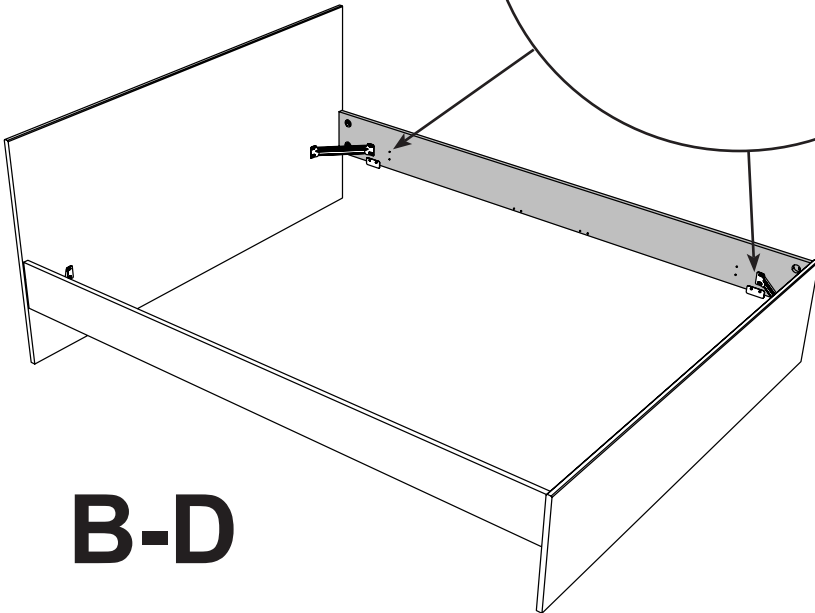
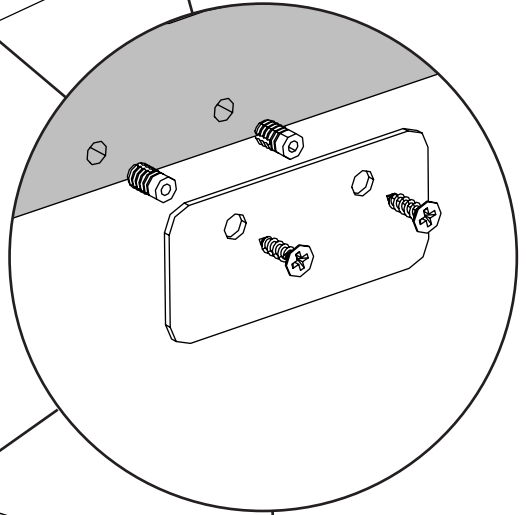
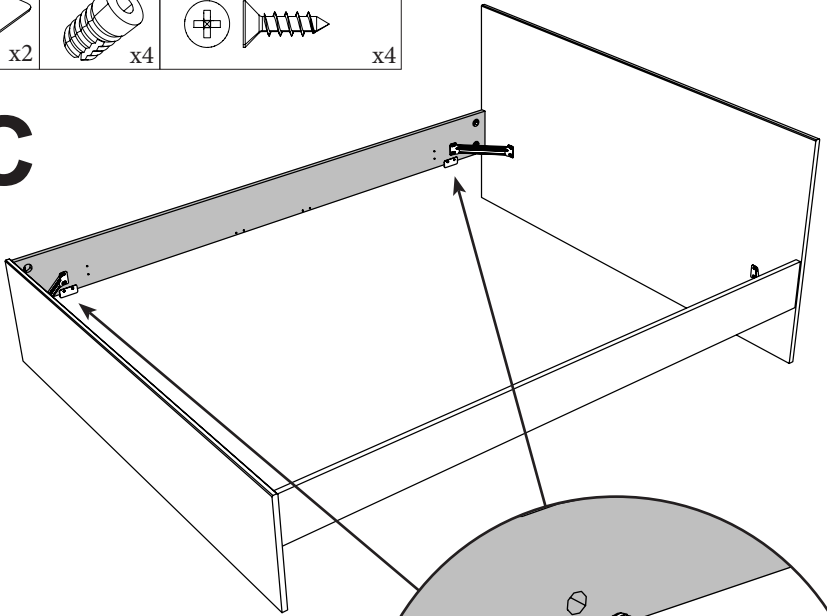

B-D

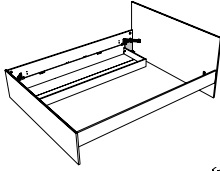
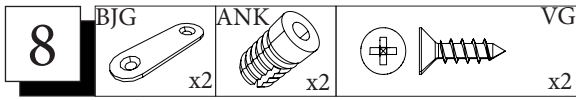

A-C

B-D

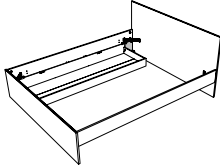
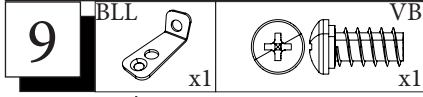
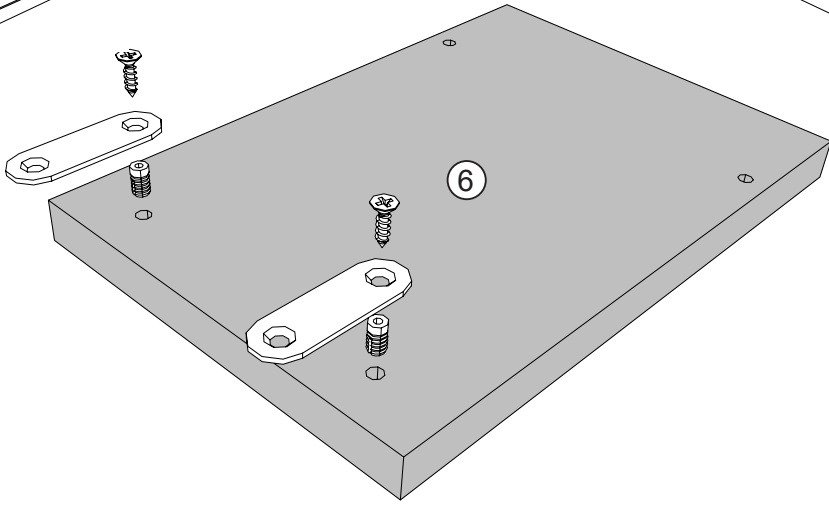
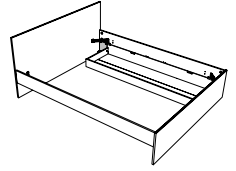

A-C

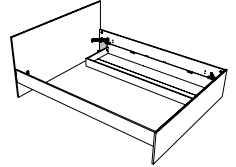

B-D

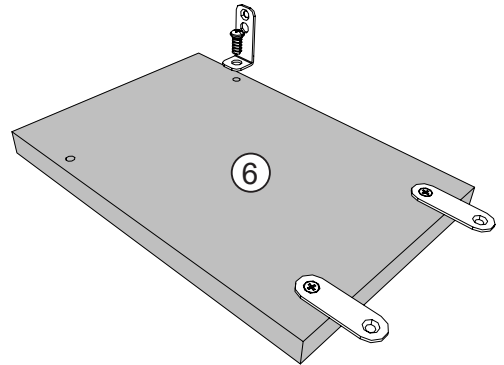
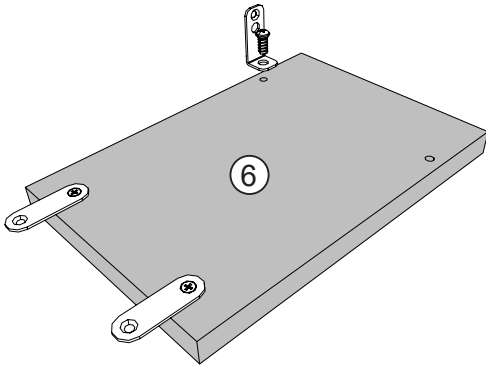
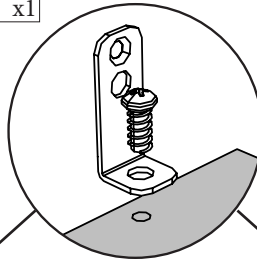

10

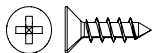

VG

x3

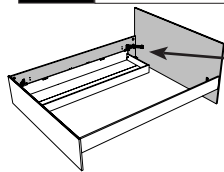

A-C

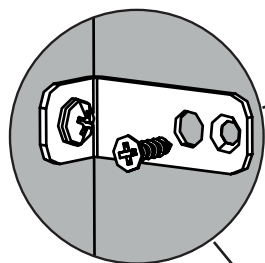
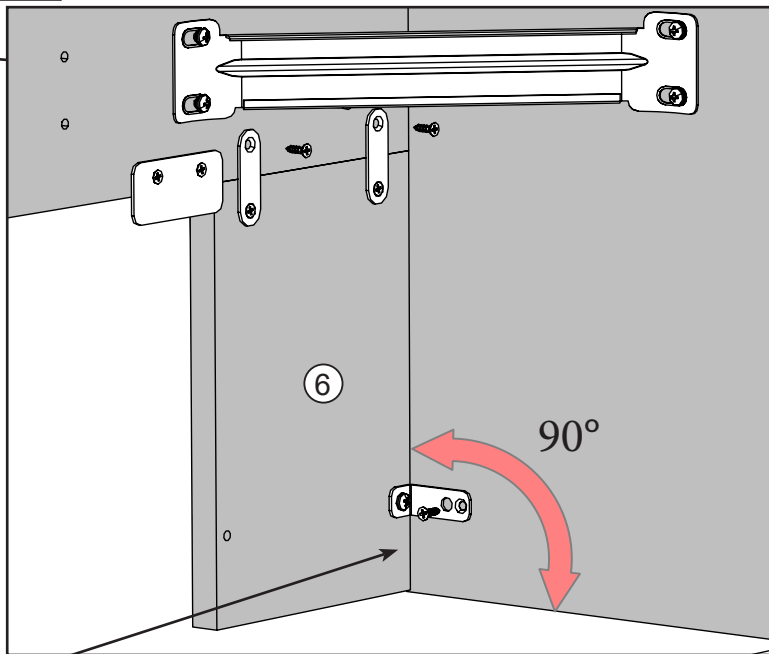

B-D

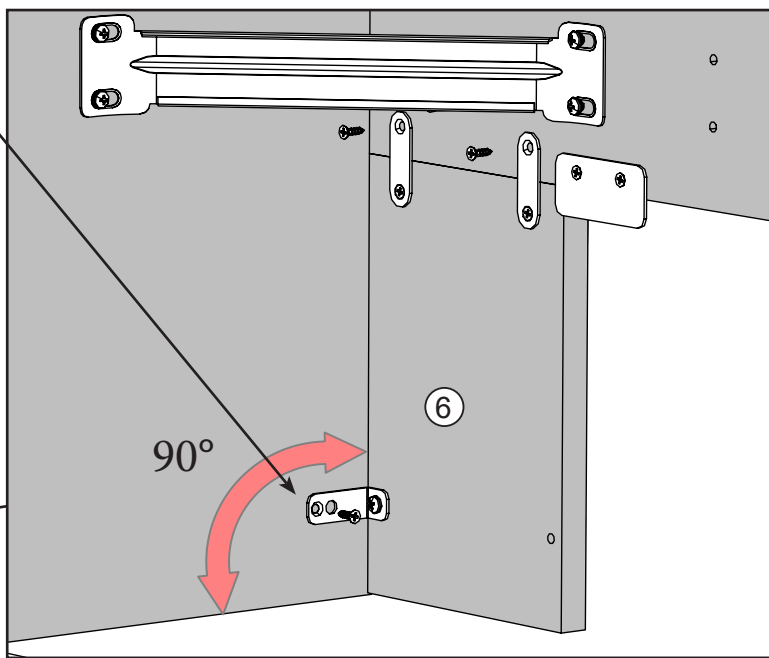
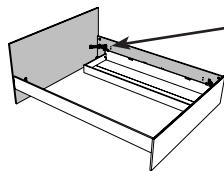

11

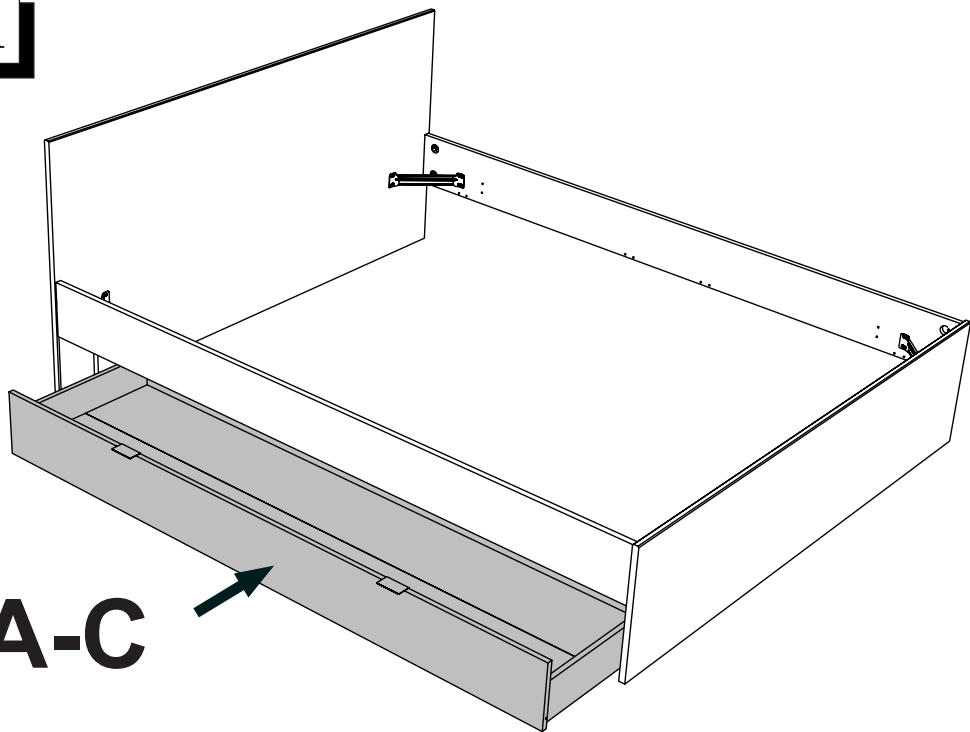

A-C

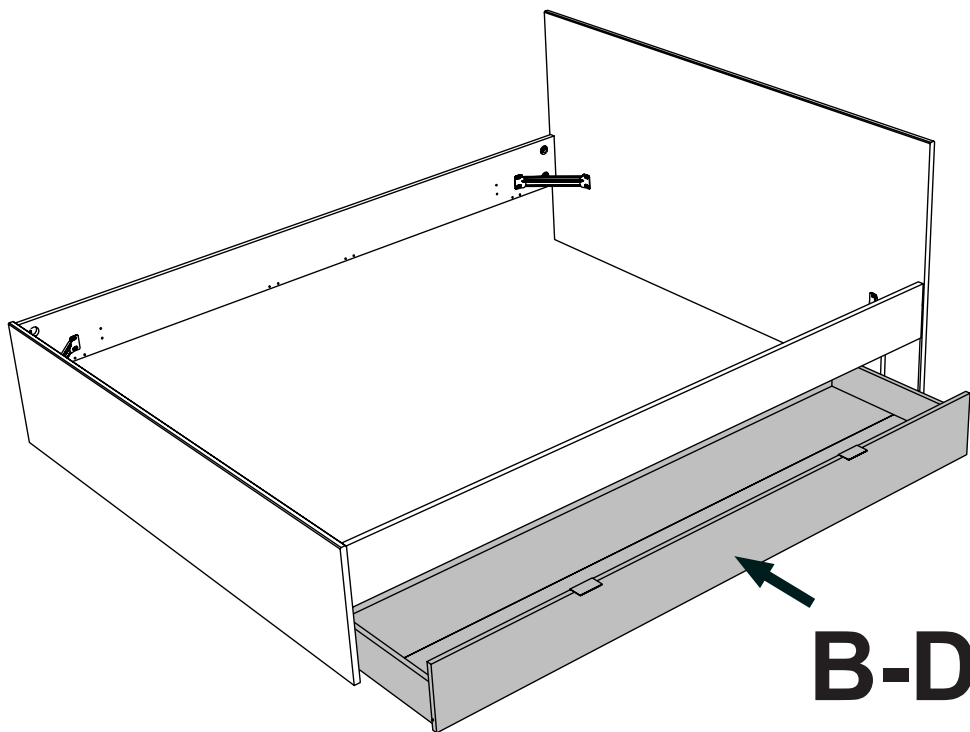

B-D



LE TRI
+ FACILE



FR

**Pensez à
donner ou recycler.**



OU



OU



Association

Magasin

Déchèterie

<https://quefairedemesdechets.fr>